

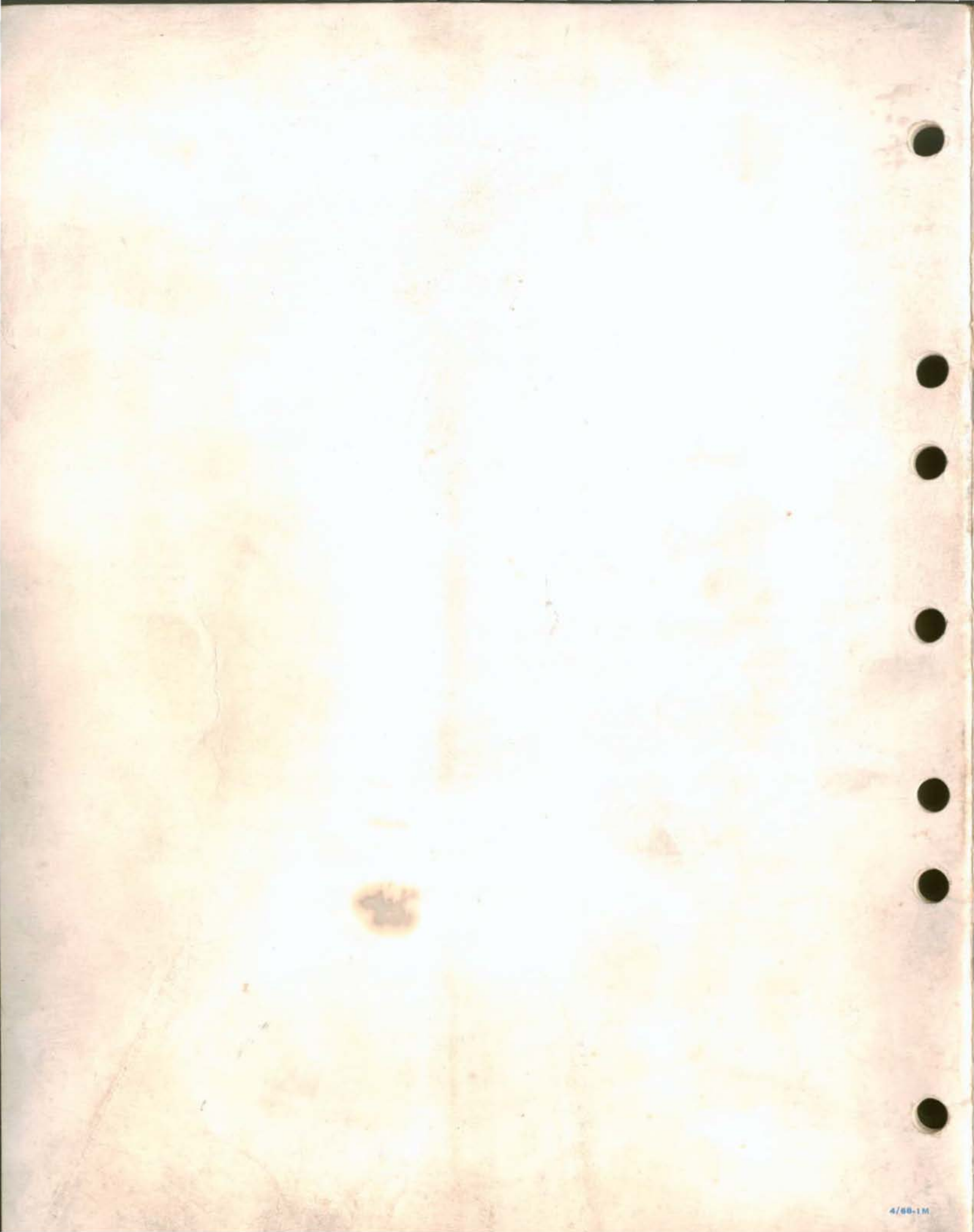

**SERVICE HINTS**



Thoughts For A Volvo  
Technician...

**QUALITY**

**BEFORE**

**QUANTITY**

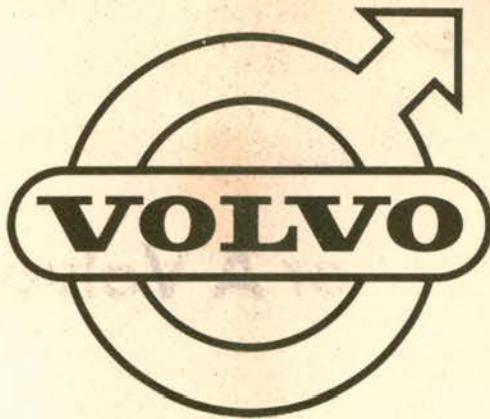

THIS "SERVICE HINT BOOKLET" IS ESPECIALLY MADE UP FOR THE VOLVO DEALERS SERVICE PERSONNEL AND IS THEREFORE NOT FOR SALE TO THE PUBLIC. THE PURPOSE OF THIS BOOKLET IS TO GIVE A QUICK ANSWER TO THE MOST COMMON SERVICE QUESTIONS.

FOR FULL DETAILS AND SPECIFICATIONS, SEE VOLVO SERVICE MANUAL AND SERVICE BULLETINS.

VOLVO, INC.  
ROCKLEIGH, NEW JERSEY

1968

# VEHICLE IDENTIFICATION



P110  
(2 Piece Windshield-P444)

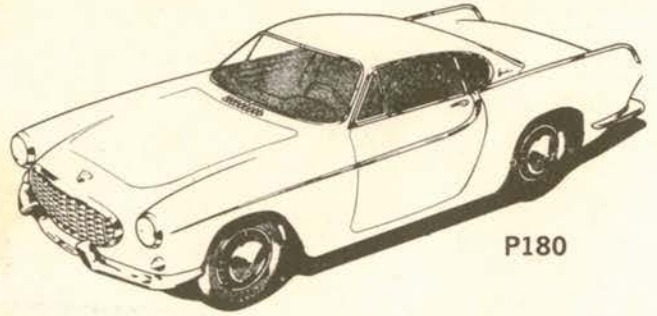

P180



P210  
(2 Piece Windshield-P445)

## 120 SERIES



P130



P120

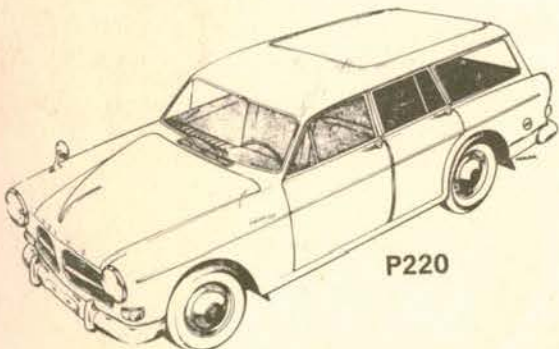

P220

## 140 SERIES

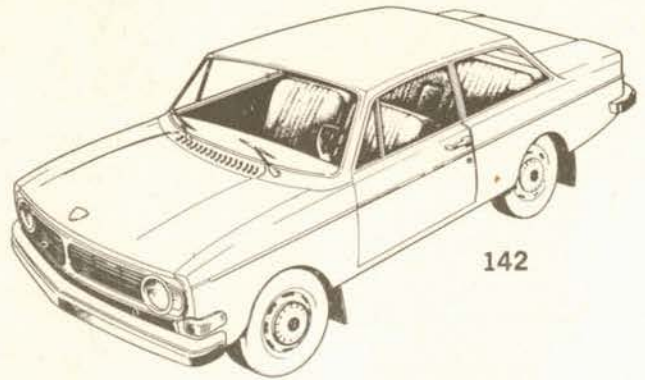

142

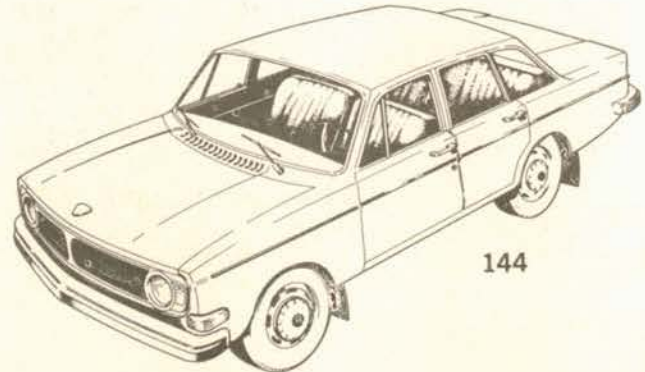

144



145

# VEHICLE IDENTIFICATION NUMBERS

## LOCATION

445-P210  
444-P110



Firewall

P120  
Series



Clutch and Brake Master  
Cylinder Housing.

P120\*  
Series (Late 1966 and onwards)



Firewall

P180  
Series



Clutch and Brake Master  
Cylinder Housing.

P180\*  
Series (Late 1966 and onwards)



Firewall

140\*  
Series



Right "A" Post

## NUMBER DESCRIPTION

Note pictures above. The pictures **not** asterixed illustrate serial number only.

The pictures **with** an asterix illustrate the total identification used from all late 1966 models and onwards. This **total** identification is used on the owner's ID card, warranty claims and all methods of reference.

THE FIRST GROUP OF NUMBERS IDENTIFY THE MODEL AND DRIVE TRAIN. THE REMAINING NUMBERS IS THE SERIAL NUMBER.

# ENGINE IDENTIFICATION

## LOCATION

B16

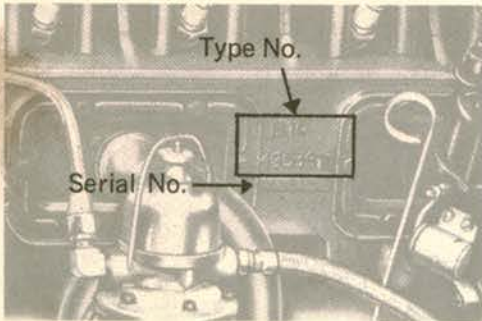

B18

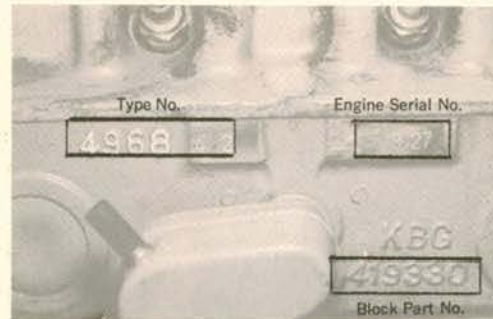

## ENGINE TYPES

Type No.	Engine type	Output B.h.p. (SAE)	Vehicle type
495382	B 16 A	66	P 110
495394	B 16 A	66	P 110
495385	B 16 B	85	445, 210, 110
495387	B 16 B	85	P 120
495396	B 16 B	85	P 120 with Saxomat clutch
496800	B 18 B	100	P 1800
496802	B 18 D	90	PV 544, P 120
496812	B 18 B	108	P 1800
496815	B 18 D	90	P 120 BW*
496816	B 18 D	90	PV 544, P 120
496817	B 18 D	108	P 1800
496818	B 18 D	90	P 120 BW*
496819	B 18 B	115	P 1800 S
496820	B 18 D	95	PV 544, P 120
496821	B 18 D	95	PV 544, P 120
496822	B 18 D	95	P 120 BW*
496836	B 18 B	115	140
496838	B 18 B	115	140 BW*
496840	B 18 D	100	P 120
496841	B 18 D	100	P 120 BW*
496842	B 18 B	115	P 1800
496860	B 18 B	115	P 120 GT
**496864	B 18 B	115	P 1800
**496865	B 18 B	115	140
496866	B 18 B	115	P 120 GT
**496867	B 18 B	115	140 BW*
**496868	B 18 B	115	P 120
**496869	B 18 B	115	P 120 BW*

\* BW—automatic gearbox

\*\* "Smog" engine

## OTHER IDENTIFICATION NUMBERS

**Paint and Upholstery Code Numbers**—These may be found on the metal plate afixed to the firewall or clutch and brake master cylinder housing.

**TRANSMISSION**— The type designation, serial number and part number may be found on a metal plate afixed to the transmission.

The transmissions which have been in service in the U.S. are:

H5—3 speed, non-syncro 1st  
H6—3 speed, non-syncro 1st  
M4—4 speed, all syncro  
M30—3 speed, all syncro  
M40—4 speed, all syncro  
M41—4 speed with overdrive  
BW—35 automatic

**REAR AXLE**— Due to the many applications of various model rear axles and ratios, we must refer you to the parts book for the respective model car.

The various models fitted are:

Model	Ratios Std
Salisbury	4.56:1
Spicer—23	4.56:1
Spicer—27	4.1:1 and 4.56:1
Spicer—30	4.1:1 and 4.56:1
Volvo —30	4.1:1 and 4.56:1

# SPECIFICATIONS

Engine	B14A	B16A	B16B	B18D	B18D	B18B	B18B	B18B	B18B Smog Engines
HP/RPM	70/5000	66/4500	85/5500	90/5000	95/5400	100/5500	108/5800	115/6000	115/6000
Torque ft. lbs./RPM	76/3000	85.4/2500	87/3500	105/3500	107/3500	108/4000	110/4000	112/4000	112/4000
Displacement cc/cu. in.	1414/86	1580/96.4	1580/96.4	1780/109	1780/109	1780/109	1780/109	1780/109	1780/109
Compr. ratio	7.8:1	7.4:1	8.2:1	8.5:1	8.7:1	9.5:1	10.0:1	10.0:1	10.0:1
Engine oil for Service API rating MS Viscosity below 32°	Recommended 10W-30 year round or SAE 10W	Recommended 10W-30 year round or SAE 10W	Recommended 10W-30 year round or SAE 10W	Recommended 10W-30 year round or SAE 10W	Recommended 10W-30 year round or SAE 10W	Recommended 10W-30 year round or SAE 10W	Recommended 10W-30 year round or SAE 10W	Recommended 10W-30 year round or SAE 10W	Recommended 10W-30 year round or SAE 10W
above 32°	20	20	20	20	20	20	20	20	20
above 90°	30	30	30	30	30	30	30	30	30
Capacity with filter change	4 Qts.	3½ Qts.	3½ Qts.	4 Qts.	4 Qts.	4 Qts.	4 Qts.	4 Qts.	4 Qts.
Capacity without filter change	3½ Qts.	3 Qts.	3 Qts.	3½ Qts.	3½ Qts.	3½ Qts.	3½ Qts.	3½ Qts.	3½ Qts.
Cooling system capacity	9 Qts.	9 Qts.	9 Qts.	9 Qts.	9 Qts.	9½ Qts.	9½ Qts.	9½ Qts.	9½ Qts.
Torque spec. Cylinder head	50-60 ft. lbs.	50-60 ft. lbs.	50-60 ft. lbs.	60-65 ft. lbs.	60-65 ft. lbs.	60-65 ft. lbs.	60-65 ft. lbs.	60-65 ft. lbs.	60-65 ft. lbs.
Main bearings	60-70 ft. lbs.	60-70 ft. lbs.	60-70 ft. lbs.	90-95 ft. lbs.	90-95 ft. lbs.	90-95 ft. lbs.	90-95 ft. lbs.	90-95 ft. lbs.	90-95 ft. lbs.
Con. Rods	30-35 ft. lbs.	30-35 ft. lbs.	30-35 ft. lbs.	40-45 ft. lbs.	40-45 ft. lbs.	40-45 ft. lbs.	40-45 ft. lbs.	40-45 ft. lbs.	40-45 ft. lbs.
Valve clearance Intake	.020"-.022"	.016"-.018"	.020"-.022"	.016"-.018"	.020"-.022"	.020"-.022"	.020"-.022"	.020"-.022"	Cold .021"
Exhaust	.020"-.022"	.016"-.018"	.020"-.022"	.016"-.018"	.020"-.022"	.020"-.022"	.020"-.022"	.020"-.022"	Cold .021"
Spark Plugs	Bosch W175T3 or Equivalent	Bosch W175T3 or Equivalent	Bosch W175T3 or Equivalent	Bosch W175T1 Alt.-W200T35	Bosch W175T1 Alt.-W200T35	Bosch W225T1 Alt.-W200T35	Bosch W225T1 Alt.-W200T35	Bosch W225T1 Alt.-W200T35	Bosch W200T35
Spark Plug Gap	.028"	.028"	.028"	.028"	.028"	.028"	.028"	.028"	.028"
Dist. Pt. Gap	.016"	.016"	.016"	.016"	.016"	.016"	.016"	.016"	.016"
Dwell Angle	47°-50°	47°-50°	47°-50°	60°-63°	60°-63°	60°-63°	60°-63°	60°-63°	60°
Timing Setting If equipped with Vacuum line, disconnect when checking Timing.	3°-5° Static	4°-6° Static	4°-6° Static	22°-24° B.T.D.C. @ 1500 R.P.M.	17°-19° B.T.D.C. @ 1500 R.P.M.	17°-19° B.T.D.C. @ 1500 R.P.M.	17°-19° B.T.D.C. @ 1500 R.P.M.	17°-19° B.T.D.C. @ 1500 R.P.M.	5° B.T.D.C. @ 800 R.P.M.
Carburetor Damper Oil	*ATF	*ATF	*ATF	*ATF	*ATF	*ATF	*ATF	*ATF	*ATF

\*Automatic Transmission Fluid, Type A

## SPECIFICATIONS (Cont'd)

	B14A SU	B16A Zenith	B16B SU	B18B SU	B18D SU
Carburetor					
Float Level	7/16"	Fixed	7/16"	Fixed	Fixed
Needle & Seat Specification	T.1		T.1	T.1	T.1
Fuel Needle Normal	CZ	Jet	GT	108 HP-115 ZH KD DX	90-95 HP-100 ZH SM
Generator out-put rated max.	160W 240W	200W 300W	200W 300W	240W 360W	240W 360W
Volts	6	6	6	12	12
Regulator	RS/US/160/S	RS/UA/200/6	RS/UA/200/6	LJ/GG240/12	LJ/GG240/12
Cut In	5.8-6.3V	5.8-6.3V	5.8-6.3V	12.1-12.8V	12.1-12.8V
Reverse Current	4-9A	4-9A	4-9A	2.0-7.5A	2.0-7.5A
Voltage Control Open Circuit	7.1-7.4V	7.0-7.5V	7.0-7.5V	13.9-14.9V	13.9-14.9V
Current Control	40A	50A	50A	30-45A	30-45A
Starter Test Values:	4.5V	4.5V	4.5V	10V	10V
Loaded	260-280A	260-280A	260-280A	200A	200A
Stalled	3.5V 450-480A	3.5V 450-480A	3.5V 450-480A	8V 400-450A	8V 400-450A

## FRONT WHEEL ALIGNMENT SPECIFICATION

MODEL	P444 P445 P544 P1100 P2100	P1200 P1300 P2200	1800S	140
Caster	-3/4° to +1/4°	0° to +1°	0° to +1°	0° to +1°
Camber	-1/4° to +1/2°	0° to +1/2°	0° to +1/2°	0° to +1/2°
King Pin Inclination	5°	8°	8°	7.5°
Toe-In	1/16"	1/16"	1/16"	1/16"
Toe-Out	22° ±1	21.5° to 23.5°	21.5° to 23.5°	21.5° to 23.5°
Tire Pressure minimum (cold tire)				
Front	20 lb./sq. in.	20 lb./sq. in.	26 lb./sq. in.	20 lb./sq. in.
Rear	23 lb./sq. in.	23 lb./sq. in.	29 lb./sq. in.	23 lb./sq. in.
Maximum (cold tire)				
Front	22 lb./sq. in.	22 lb./sq. in.	26 lb./sq. in.	22 lb./sq. in.
Rear	30 lb./sq. in.	30 lb./sq. in.	29 lb./sq. in.	30 lb./sq. in.

## SERVICE TIPS

The tips on the following pages are not meant to replace general working procedures and specifications found in the workshop manual or workshop bulletins. In all cases the manual and bulletins are the main publications to work from.

### ENGINE

#### EXHAUST EMISSION CONTROL SYSTEM

##### GENERAL DESCRIPTION

Volvo has developed an exhaust emission control system in accordance with the principle of a more complete combustion which reduces the contents of carbon monoxide and hydrocarbons in the exhaust gases to meet the requirements of the Clean Air Act. This is achieved mainly by a modified induction system that enables a more exact and leaner mixture ratio between fuel and air to be used.

The figures below show how the system works in the B 18 B engine.

##### Description

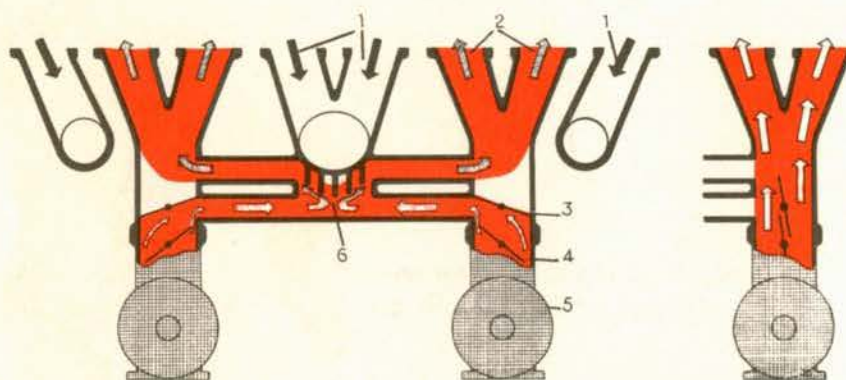

1. Exhaust manifold
2. Intake manifold
3. Intake manifold throttle

4. Carburetor throttles
5. Carburetor
6. Preheating chamber

The intake manifold has been equipped with two throttles (3). For normal driving the throttles (3) are closed (left, figure) thus forcing the mixture of fuel and air from the carburetors to a central preheating chamber (6) where the intake charge is heated and thoroughly mixed whereby a completely evaporated and homogenous mixture is obtained. This results in the system being insensitive to fuel mixture synchronization of the carburetors. When higher output is required, the throttles (3) open up (right, figure) and the mixture of fuel and air can pass directly to the cylinders without passing the preheating chamber. In this way, the full engine-output can be developed without restrictions in the intake system. In other words, the engine has been furnished with a dual intake system; a low output system and a high output system. During city driving when normally only lower output is being used, an improved fuel economy is also achieved.

The change from the low output system to the high output system is automatically controlled as the carburetor throttles (4) and the intake manifold throttles (3) are connected by means of a simple cam system. This occurs at approximately two thirds throttle opening.

## EXHAUST EMISSION CONTROL SYSTEM

### SPECIFICATIONS

The primary throttle is fitted with a spring-loaded valve (Fig. II) which opens during engine braking and supplies extra air for more complete combustion. Should these valves not close properly, the engine will not return to idle. Check valves, timing and carburetor mixture for proper setting before the carburetor valves are inspected.

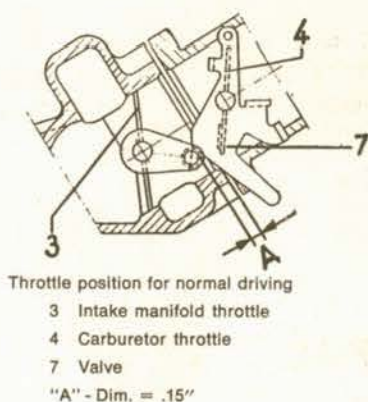

FIG. I

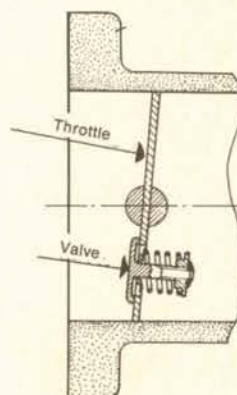

FIG. II

In order to facilitate centering of the fuel jet, a steel washer has replaced the brass washer between the upper bearing for the jet and the nut. The upper part of the fuel needle has been redesigned for leaner mixture at slow speeds.

Fuel Needle—"DX"

Damper Oil—ATF (Automatic Transmission Fluid) Type A

Spark Plugs—Bosch W200T35—Gap .028"

Ignition Timing—5° B.T.D.C. @ 800 R.P.M.

Distributor Cam Dwell—60°

Valves (cold)—.021"

Fuel—**Minimum**, 100 octane (Research Method)

The distributor advance curve has been modified to suit this system.

Distributor—Bosch JFR 4 (L) 0231 153 009 with Centrifugal governor.

Crankshaft degrees	0°	15°	29° ± 2
Crankshaft R.P.M.	900-1100	1400-1650	3100

## EXHAUST EMISSION CONTROL SYSTEM

### GENERAL REPAIR INSTRUCTIONS

The instructions regarding the disassembly and assembling of the carburetors are according to the service manual for the B 18 B/D engine with the following exceptions:

#### Secondary Throttles

Check that the secondary throttles in the intake manifold are centered and the throttle spindles move easily. Check the location of the levers as shown in Fig. I, that is, with the secondary throttle in the closed position, the distance from the pin of the lever to the surface of the intake manifold flange should be .15". Check that the rubber seal (8, Fig. III) is not damaged and its inner flange seals well against the intake manifold. If it should prove necessary to fit a new seal, make sure it is not damaged by the sharp edges of the throttle shaft. It must be fitted so that the measurement "B" of .18"-.20" as shown in Fig. III is obtained. Make sure both throttles are engaged at the same time and open fully.

#### Jet Centering

Place the carburetor with the four-holed flange against a horizontal surface. Screw up the jet adjusting nut fully so that the jet comes above the bridge. The jet lock nut is then loosened and the jet is centered by pushing the suction chamber piston downwards and then forward and backward. After centering, tighten the lock nut. Check the centering by lifting the suction chamber piston about one quarter inch and allow it to fall freely. The piston should strike firmly against the jet.

#### Checking the Suction Chamber Piston Stroke

With the carburetor in the same position for jet centering, move the suction chamber piston slowly to its top-most position. The movement should be free and smooth. When released, it is most important that the piston should return at an even speed and strike against the jet with a clearly audible noise.

#### Basic Jet Adjustment

The jet adjusting nut on each carburetor must be screwed down from its uppermost position (as described above) so that the jet is **just** level with the top of the bridge. **From this position, screw down the adjusting nut of each carburetor, 16 flats.** Make sure that the starting point of the jet adjustment is when the jet is level or even with the bridge.

#### Basic Setting of Idle Speed

First, be absolutely sure there are no burrs on the contact surface of the idle speed adjusting screws. Then, screw in the idle speed adjusting screws until contact is just made with the lever and then a further 1½ turns.

## EXHAUST EMISSION CONTROL SYSTEM

### GENERAL REPAIR INSTRUCTIONS (Cont'd)

#### Dampers

The oil in the damper cylinder (ATF Type A) must be  $\frac{1}{4}$ " from the upper edge of the inner spindle.

All the aforementioned adjustments are basic adjustments which are made prior to starting and warming up the engine and this would also include the correct adjustment of valves, dwell and timing.

The adjustments described below must not be attempted on any hot engine. All idle mixture adjustments must be within the 1 to 3 minute period following the opening of the thermostat. As soon as the upper radiator tank becomes warm is the determining point.

#### Final Adjustments

The mixture setting **must** be made at room temperature (68°F) **at approximately 1-3 minutes after the engine has reached its normal operating temperature** (warming up by running at idle speed).

The setting should be made with a CO-gauge according to method "A" described below, but the setting may be made where necessary in accordance with method "B" described below.

#### A. Setting with CO-gauge

1. Connect a tachometer and the CO-Gauge. Run the engine to operating temperature as instructed above.
2. Set the idling speed to 800 R.P.M. by adjusting the idle speed screws so that both carburetors have the same intake noise or if using a uni-syn gauge, the same reading.
3. From the basic setting of 16 flats down on each carburetor, adjust the mixture on **the rear carburetor** until a CO-Value of 3.0 to 3.5% is obtained.
4. Readjust idling speed to 800 R.P.M. with transmission in neutral and any accessories in "off" position.

#### B. Setting Manually

Basic setting must be made as previously instructed.

Adjustments below to be made only 1-3 minutes after the engine has reached normal operating temperature.

1. Connect a tachometer and run the engine to warm at idle speed.
2. Set the idling speed to 800 R.P.M. by adjusting the idle speed screws so that both carburetors have the same intake noise or if using a Uni-Syn gauge, the same reading.
3. From the basic setting of 16 flats down on each carburetor, **adjust the mixture on the rear carburetor** to give maximum idle speed. In order to check your setting, adjust towards a leaner mixture and watch for an R.P.M. drop (25-50). The correct mixture setting is that point where the R.P.M. is the greatest.
4. Readjust idling speed to 800 R.P.M. with transmission in neutral and any accessories in "off" position.

#### Choke-Fast Idle Adjustment

1. Adjust the choke control so that the jet of the front carburetor begins to drop when the dashboard control is drawn out  $\frac{3}{4}$ ". Adjust the jet of the rear carburetor with the dashboard control drawn out  $1\frac{1}{8}$ ". For the P1800, use  $\frac{5}{8}$ " for the front carburetor and  $\frac{3}{4}$ " for the rear carburetor.
2. The fast idle speed adjusting screws are adjusted with the choke control fully pushed in so that the distance between the screw and the cam is .008" for the front carburetor and .016" for the rear carburetor. Note that the final idle speed adjustment must be made before setting fast idle.

# EXHAUST EMISSION CONTROL SYSTEM

## GENERAL REPAIR INSTRUCTIONS (Cont'd)

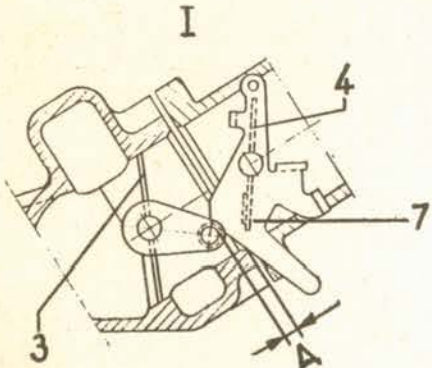

Throttle position for normal driving

- 3 Intake manifold throttle
- 4 Carburetor throttle
- 7 Valve
- "A" - Dim. = .15"

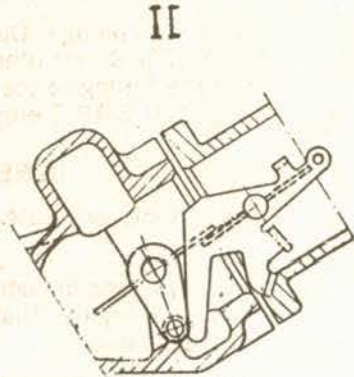

Full throttle position

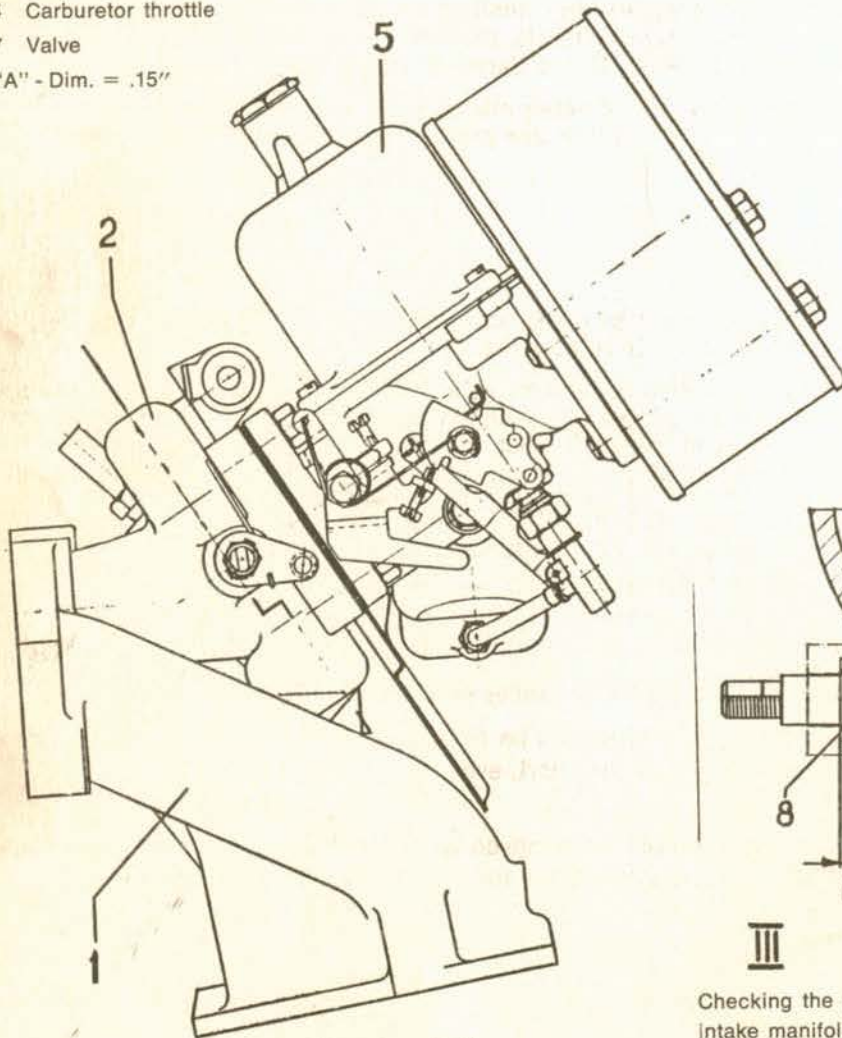

- 1 Exhaust manifold
- 2 Intake manifold

Checking the rubber seal for the intake manifold throttle spindle

- 8 Rubber seal
- "B" - Dim. = .18" - .20"

Listed below in order of their importance, are points to be checked to overcome the problem of after-running.

**B 18 B  
ENGINES  
AFTER RUNNING—**

1. **Idle Speed**—Idle R.P.M. which is too fast will definitely result in after-running. Set to specifications. (Ref. Bul. 20 US 5 of January 1968).
2. **Fuel**—your customer must be advised to use fuel with an octane rating of 100 or above. You will find it more desirable to refer to "Super Premium" rating than octane rating.
3. **Ignition Timing**—Our specifications call for 3°-5° for "Smog" engines and 17°-19° for other B 18 B engines, however it is always beneficial to set the timing to the highest value. I.E., 5° for "Smog" engines and 19° for other B 18 B engines.

**GENERAL**

The **tachometer** used must be reasonably accurate to ensure the idle and timing are set to the correct specifications.

The **spark plugs** must be the specified type and in good condition. We recommend that spark plugs should be replaced every 12,000 miles, however engines that are subjected to more severe service may require a spark plug replacement prior to 12,000 miles.

**Valve clearances** affect idle and must be checked in the event other adjustments fail to fully cure the problem.

**Fuel mixture** has not been mentioned because of the small affect it has on after-running on "smog" engines. The carburetors are set to give the ideal emission levels, therefore any resetting of the idle mixture must be done in accordance to Service Bulletin 23 No. U.S. 1 dated January 1968.

**High underhood temperatures** give the result of richer mixtures and leaning of the mixture at this time will result in a lean mixture when normal temperatures are present. Setting of the idle mixture should only be made at more normal temperatures (68°F).

**B 18  
OIL PAN REMOVAL—**

The engine must be removed or the front cross member dropped a sufficient amount in order to remove the oil pan.

**B 18  
CAMSHAFTS—**

Early production camshafts were identified by a part number stamped on the rear of the shaft. Late production camshafts are identified by a letter stamped on the rear of the shaft. They are identified as follows by engine.

- B 18 D 90 H.P. — "A" — Part #418207
- B 18 D 95 H.P. — "B" — Part #418266
- B 18 B 100 H.P. — "B" — Part #418266
- B 18 B 108 H.P. — "C" — Part #418707
- B 18 B 115 H.P. — "C" — Part #418707

**CRANKCASE  
VENTILATION VALVE—**

Replace at every 24,000 miles or earlier if necessary.

**B 18  
PISTONS  
LATE TYPE—**

The new type pistons can be fitted to earlier engines only in sets of four. They are recognized by the short, even skirt.

**ANTI-FREEZE AND  
COOLING SYSTEM—  
FLUSHING**

Anti-freeze should be removed after a period of one year and cooling system flushed with an agent made for use with aluminum components.

## ENGINE OVERHEATING—

Overheating can be the result of many items besides the shortage of coolant. Listed below is a quick reference to most items that can affect engine temperature. Before attempting corrective work insure that the temperature gauge is working correctly.

### Most Common Causes:

Too little coolant, Fan belt loose, Cracked or faulty hoses, Faulty thermostat, Core fins obstructed with grass seeds or insects etc.

### Not So Common Causes:

Faulty radiator cap, Fuel mixture too lean, Radiator blocked, Leaking cylinder head gasket, Ignition timing incorrect, Water pump impellor damaged, Water distribution pipe in cylinder head faulty.

While the above mentioned items could apply to many different makes of cars, the following items apply to Volvo:

### B 16 Series Engines:

These engines are equipped with a "by-pass hose" between the water-pump and cylinder head. Should this hose deteriorate it can restrict the flow of coolant and/or deposit pieces of rubber in the water distribution tube in the cylinder head.

### B 18 Series Engines:

These engines are equipped with a dual purpose thermostat that positively controls the water pump by-pass. Should the by-pass valve section of the thermostat or the thermostat itself be removed, overheating can result. If these items are operating satisfactorily the water distribution tube should then be inspected.

Winter thermostats and extra cooling fans are both available from the Spare Parts Department.

NOTE: All Volvo cars should be equipped with four bladed fans.

## CLOSED TYPE COOLING SYSTEM—

This is fitted with a plastic expansion tank.

The coolant level must be kept between the minimum and maximum marks on the expansion tank. Topping up must be made **only** at the expansion tank.

An empty system is filled through the filling hole of the radiator. Usually the cap is tight but it can be removed by carefully using water-pump pliers.

## OIL FILTERS— B 18

Original replacement Volvo oil filters are engineered to Volvo specifications and must be used. Volvo cannot accept responsibility for engine damage resulting from use of non-original oil filters.

The crankshaft is surface hardened, therefore only Volvo original replacement bearings must be used.

Oil consumption on new engines is quite normal and is because of a fine finish of the cylinder bores and piston rings. Longer engine life however is the result. Oil consumption should be negligible after approximately 6000 miles. It is important that the oil used is designated MS. We specifically recommend the use of multi-purpose oils SAE 10W-30.

## GAS MILEAGE

Many factors can contribute to gas mileage. When receiving complaints of poor gas mileage the following items should be taken into consideration:

- Weather Conditions** — Head winds correspond to higher speeds.
- Additional Equipment** — Roof racks and air-conditioner absorb horsepower.
- Tire Pressures** — Low tire pressures result in extra drag.
- Driving Habits** — Fast driving or using lower gears consume additional gas—steady driving with constant throttle pressure give best results.
- Ignition System** — Faulty components in the ignition system result in poor performance—(this also includes the spark timing).
- Carburetors** — Having the correct mixture setting will not do the job, if other parts of the carburetor are not operating as they are supposed to.

MAKE SURE OF THE FACTS BEFORE DOING REPAIRS TO CORRECT LOW MILEAGE COMPLAINTS.

# ELECTRICAL

## CHARGING SYSTEM

General output must not be checked by grounding the field terminal of the generator while still connected to the regulator otherwise the regulator will be damaged beyond control.

A loose fan belt is a very common cause of insufficient charging rate, especially in the winter when the use of more electrical components create extra loading of the generator.

A glowing generator light when driving can many times be traced to corrosion at the fuse holders. This can be corrected by cleaning of the contacts and fuses.

## SEV-Motorola ALTERNATOR, 123GT

The 123GT model Volvo is not being imported into the U.S., however, some of these models have been brought in by individual customers. This following is for your general information in the event service may be required.

### Fitting, testing and servicing of alternator.

Alternators have a certain number of advantages, but at the same time the electronic components fitted in the alternators and charging regulators are sensitive to such things as reversed polarity.

We would like therefore to give the following points concerning what should be observed when carrying out work on vehicles fitted with alternators.

1. Reversed battery connection damages the rectifiers. The polarity of the battery should be checked with a voltmeter before connecting up.
2. If extra batteries are used for starting purposes, they must be correctly connected in order to prevent the rectifiers from being damaged.  
The negative lead from the auxiliary battery must be connected to the negative terminal of the car battery and the positive lead on the auxiliary battery to the positive terminal.
3. If a fast-charger is used for charging the battery, the car battery leads must be disconnected.  
The fast-charger must never be used for starting assistance, otherwise both the alternator and regulator will be ruined.
4. On no account must the field circuit be grounded with the regulator engaged and the engine running. This will destroy the regulator immediately.
5. Grounding of the alternator output terminal damages the alternator and can ruin the regulator.
6. Never break the main lead or field lead of the alternator with the engine running, as this can damage both the alternator and the regulator.
7. Do not try to polarize the alternator.  
No polarization is necessary and attempts to do this can ruin the regulator.
8. When removing the alternator from the car, or carrying out any other work on the alternator and regulator, always disconnect the ground lead first.
9. When carrying out welding operations on vehicles fitted with an alternator, first disconnect the ground lead of the battery and then all the leads to the generator and charging regulator. Make sure that disconnected lead ends do not come into contact with the chassis. If necessary, insulate the ends well.

SEV-Motorola ALTERNATOR, 123GT

Pos. No.	Fig. 1	Qty.	Part Number	Description
1		1	419420	Alternator
15		1	419589	Regulator
17		1	955779	Nut B6LM 4 x 0.7 x 3.5, D 80 regulator
16		1	941904	Resilient washer 4.3 regulator
18		2	958236	Bolt RXS B 12 x 12
19		2	941906	Washer FBB - 6
2		1	955565	Screw
3		1	940280	Resilient washer
4		1	419376	Tensioner arm
5		1	955523	Screw
6		1	955524	Screw
7		1	191172	Washer
8		1	419407	Drive belt

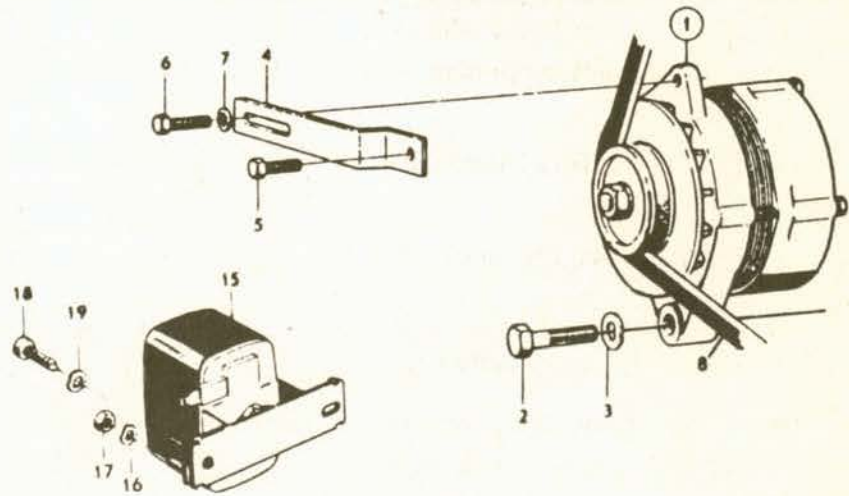

VOLVO  
110512

Fig. 1

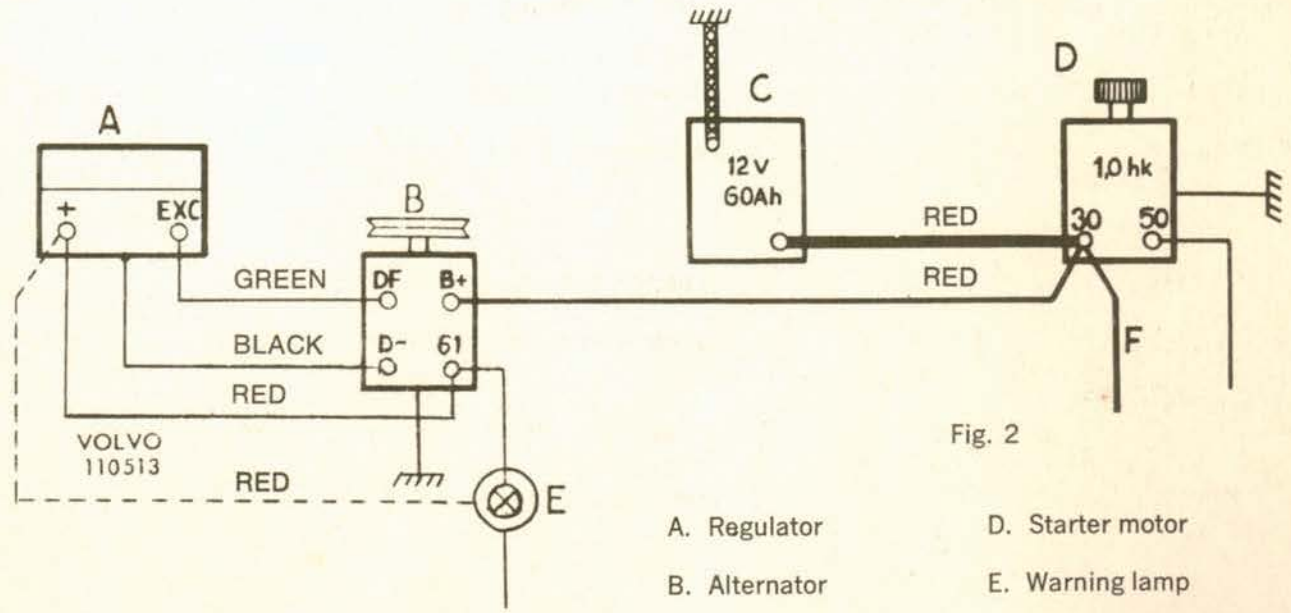

Fig. 2

- A. Regulator
- B. Alternator
- C. Battery
- D. Starter motor
- E. Warning lamp
- F. Lead to ignition switch

## **SEV-Motorola ALTERNATOR 123GT**

In case of any complaint of a "no-charge" condition, the following must be checked before any exchange of parts is made:

1. See that the drive belt is tight—A loose belt gives the same result as a poorly adjusted regulator.
2. See that the charging light bulb is not burned out. A burned out or open circuited bulb will prevent the alternator from charging.
3. See that the regulator cover is not forced down so as to open the regulator points. This can best be checked by pulling the cover while checking the voltage reading. Should the voltage increase, remove and inspect the regulator.

## **Model 140 Series Battery**

For replacement purposes, a domestic battery with code 24FN3 can be used.

When removing the battery for any reason, make sure when reinstalling that the ground strap is fastened so that it cannot contact the headlight unit terminals.

## **SPARK PLUGS**

The spark plugs used in B 18 D and B 18 B engines are designed to operate under "normal" conditions. It is therefore possible that a "hard" driven B 18 D can burn the plugs, resulting in short plug life or that the B 18 B engine be subjected to "soft" driving that can result in fouled plugs.

In order to accommodate both of these conditions our Parts Department now has available an extended tip spark plug that can be ordered under part number 75053. (Bosch W200T35)

# TRANSMISSION/CLUTCH

## CLUTCH

It is imperative that only an original Volvo spare parts clutch Disc is used as a replacement otherwise noise and/or vibration can result.

The pressure plate should always be checked for correct release lever height alignment.

Correct clutch adjustment is important. Hydraulically actuated clutches are checked and adjusted at the operating cylinder push rod. The clearance should measure 1/8".

A diaphragm type clutch assembly should only be mounted to the corresponding type flywheel which has three retaining dowels. The pressure plate is non-adjustable. It is standard equipment on all models now. There are several types of diaphragm pressure plates being fitted. The corresponding throw-out bearing must be fitted with it. See parts books for specifics.

## TRANSMISSION

It is imperative that **only SAE 30** motor oil is used with the M41 transmission and overdrive. Filling is done through the normal filler plug on the transmission. Total capacity of transmission and overdrive is 3.2 pints. Filling can be somewhat slow.

All transmissions **without** overdrive use SAE 80 gear oil. Capacity of transmission **without** overdrive is 1.6 pints.

## BW - 35

Reports from the field describe a "boiling" of fluid with resulting over-flow from the transmission filler pipe. In order to avoid this problem, the level of the fluid in the transmission must be kept **below** the full mark.

Under no circumstances must the transmission be filled with fluid above the full mark on the dipstick.

When checking the fluid level the transmission should be at normal operating temperature. **Normal operating temperature** can only be reached by driving the car for one to two miles.

Move selector to 'P'. Run engine at idle speed for two minutes then check fluid level.

The difference between the "high" mark and the "low" mark is slightly less than **one pint**. Topping-up should therefore be carried out carefully.

## REAR AXLE

Multi-purpose type grease grade 90 which is commonly supplied by major oil companies may be used. The capacity is 2¾ pints. Hypoid type lubricant must be used on all Volvo rear avles.

If positraction is fitted, a special lubricant which is available on the domestic market, must be used. It should meet the American military standard MIL-L-2105B.

### Pinion Oil Seal

A new pinion oil seal with improved sealing properties has been introduced into production. It has a neoprene double lip seal which is spring loaded for more positive sealing.

THE GASKET PREVIOUSLY USED MUST NOT BE USED WITH THIS NEW SEAL.

The sealing lips and the spring must be smeared with grease prior to installation. The use of special tool SVO2806 will enable an accurate installation and prevent the spring from jumping out of place.

Description	New Part No.	Deleted Part No.
Pinion Oil Seal	942905	80507.
Gasket	.....	80508

### Axle Setting

The **Volvo** Axle Model 1030(30) is manufactured with special spacers to set pinion height and bearing pre-loads. These spacers are not available for servicing. Individual shims available from the parts dept. must be used.

## REAR AXLE (Cont'd)

### SVO2806—Drift for fitting Pinion Oil Seal.

The introduction of the new type pinion oil seal (service Bul. Gr. 46, No. 17, Jan. 1968) has necessitated the introduction of a new Drift for fitting the seal.

The earlier Drift SVO2403 does not satisfactorily install the new type seal, therefore it must be replaced by SVO2806.

The sealing lips and the spring of the new seal must be smeared with grease prior to installation. The use of this tool results in an accurate installation and tensions the spring thus preventing it from jumping out of place.

See Figure.

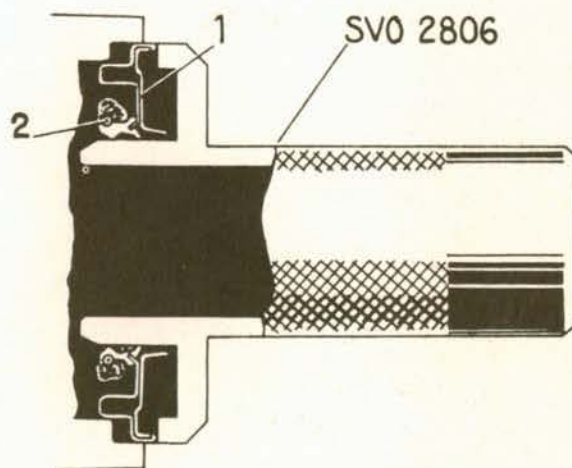

VOLVO  
110576

1. Sealing ring
2. Spring coil which is coated with grease

### Rear Suspension

Noises emitting from the rear of the car can many times be traced to **improperly torqued nuts and bolts on the suspension components**. It can also happen when the rear is loaded, the coil springs may possibly bow and rub against the upper member. This can be corrected by rotating the spring to give adequate clearance. Excessively tightened upper shock absorber nuts can also cause a noise conversely so can loosely tightened nuts.

# BRAKES (DISC BRAKES)

## GENERAL

Refacing of the discs must only be done on a machine designed for this purpose. Use of other types of refacing machines can result in an unsatisfactory job. Do not reface beyond minimum specified in shop manual.

**Only brake fluid** fulfilling the requirement of **SAE 70R3** must be used. Any lesser grade of brake fluid is not recommended.

The brake pads will give better wear if the outside and inside pads are switched at the 24,000 mile inspection. The 144 pads are **not** interchangeable (inside and outside) on the **same** wheel (caliper).

## WARNING VALVE

The warning valve, the design of which is shown in Fig. 1, is connected to the same warning lamp as the handbrake. If there is too large a difference in pressure (113-142 lbs./sq. in.) between the circuits when the brake is applied, the plungers are displaced and the electric circuit cuts in, see Fig. 2.

### Resetting of the warning valve.

1. Disconnect the electric cable and screw out the electric contact so that the plungers return to their normal position.
2. **Repair and vent the faulty hydraulic circuit.**
3. Carefully screw in the electric contact (tightening torque (10-15 lb. ft.)). Connect up the electric cable.

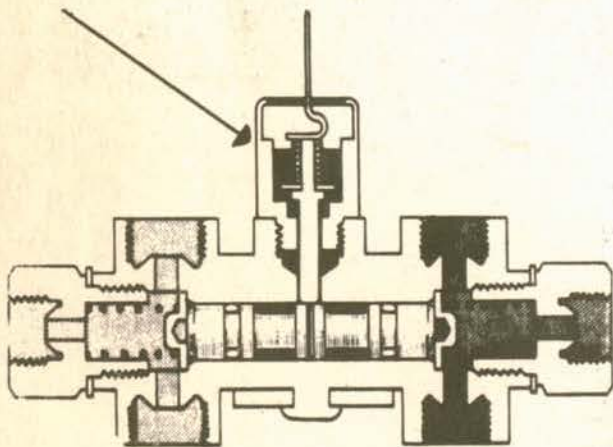

Fig. 1. Normal position

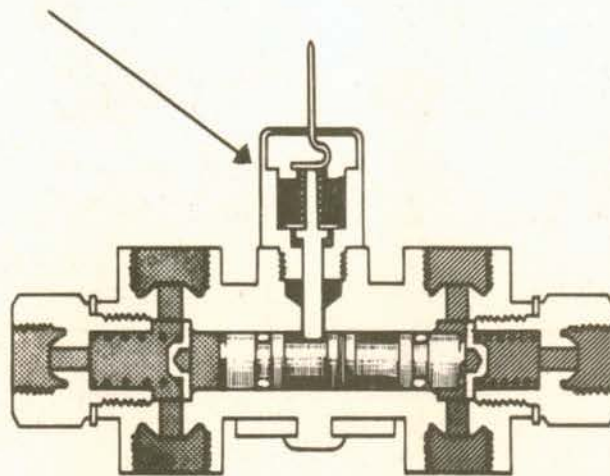

Fig. 2. Warning position

## BRAKE SYSTEM—140

Procedures to be followed when bleeding the 140 brakes:

- 1) Press the brake pedal several times to exhaust any vacuum in the servo unit.
- 2) Remove the switch from the warning valve.
- 3) Clean around fluid filler cap(s) and if necessary top up with fluid (SAE 70 R 3). Do not use second hand fluid.
- 4) When bleeding use SVO tool 2740 with hose extending to bottom of container. Open bleeder nipple and have the brake pedal carefully pressed about each five seconds until fluid is clear of air-bubbles. Be sure there are no air leaks between tool and nipple.
- 5) After bleeding see that the fluid reservoir(s) are filled to the "MAX." level. See that the cap vent holes are clear before fitting to reservoirs.
- 6) Replace the warning valve switch and tighten to 10-15 lb. ft. connect cable.

Illustrated below are the two types of Brake Fluid Reservoirs used and their corresponding methods of bleeding.

### EARLY

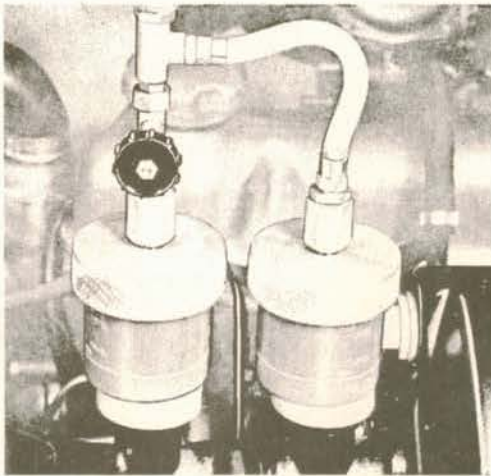

"AKB" Pressure Valves located in bottom fitting of reservoirs

#### BLEEDING SEQUENCE—EARLY

Bleed primary (rear reservoir) system first:  
Right Rear  
Right Front—lower (inner and outer)  
Left Front—lower (inner and outer)

Bleed secondary system last:  
Left Rear  
Right Front—upper  
Left Front—upper

### LATE

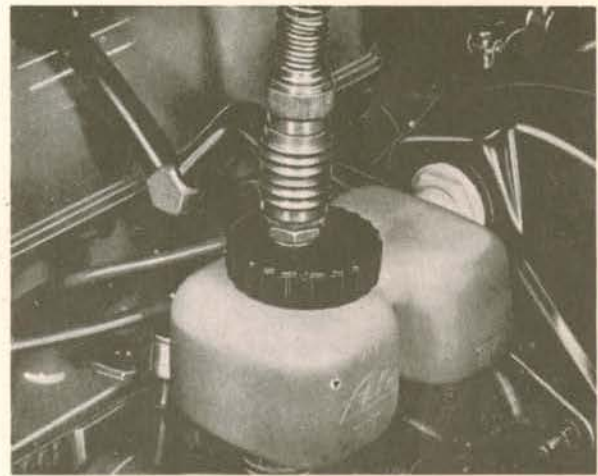

"ASB" Pressure Valves located in Rear Brake calipers

#### BLEEDING SEQUENCE—LATE

Bleed secondary system first:  
Left Rear  
Right Front—upper  
Left Front—upper

Bleed primary system last:  
Right Rear  
Right Front—lower (inner and outer)  
Left Front—lower (inner and outer)

---

### PRESSURE TANK SYSTEM

Any Pressure Bleeder used must be equipped as illustrated above. The pressure bleeder must maintain a constant pressure of 30-35 lbs. per sq. inch.

**Note:** On dual reservoirs, the valve on the secondary cap must be closed until the primary circuit is bled. See Illustration.

## TIRES

The U.S. replacement size for Volvo standard tires (165 x 15) and snow tires is 685 x 15L. (Low section height)

Emergency snow chains must not be fitted to the front or rear wheels of the 140 series due to wheel/brake caliper clearances.

Radial tires should only be fitted in sets of four. If only two are mounted, they should be put on the rear.

While the normal maintenance schedule does not call for tire rotation on a regular basis, there are occasions when periodic rotation could be beneficial. Wheel balance should be checked accordingly.

---

## BODY

### 142 QUARTER WINDOW

The rear quarter window is removed by disconnecting the handle from the body member and swinging the window outwards. This will allow the hinges to release from the "B" post. Reverse the above procedure for installation.

## VOLVO PAINT FINISH

Volvo cars have a baked enamel finish, when touch-up or repaint use Volvo **enamel** paint only. Polishes and waxes suitable for enamel paint must only be used. We recommend the use of Volvo polish and wax. Abrasive type cleaners and wax must not be used.

### Cleaning of New Cars

Contact your distributor for specific instructions on **REMOVING** preservative wax.

**DO NOT** apply solvents with a rag or agitate the solution on a dirty car as it will scratch the finish on the car.

**DO NOT** try to improve a poor clean-up job by polishing the car, because the polish on top of the protective wax will make the finish dull and hazy. **REMEMBER** on a thoroughly cleaned new car, polishing and/or waxing is not necessary nor recommended.

Listed below you will find the colors, the color codes, & the respective part # for air-drying enamel used on the Volvo cars.

COLOR	COLOR CODE	2.2 LB.	TOUCH-UP	SPRAY CAN
Black	19, 49, 50	79982	277020	277500
Pearl-grey	20, 59	79984	None	None
Metallic red	21	79936	None	None
Beige	22, 23, 24, 35	279043	None	None
Royal blue	23	279041	None	None
Grey	24	279039	None	None
Midnight blue	31, 35, 45, 54	79980	277022	277501
Riveria blue	33	279045	None	None
Red	36	279094	None	None
Ivory	42	279256	277024	277502
Red	43, 46, 51	279266	277025	277503
Grey-beige	43, 44, 45, 49 50, 51, 54, 65	279262	277026	277504
Dark green	47	279314	None	None
Golden beige	48	279318	277028	277505
Olive green	56, 59, 68	279694	277029	277506
Olive green	56-1, 68-1	277074	277029	277506
Slate blue	67	277068	277030	277507
Slate blue	67-1	277158	277030	277507
Fawn	72	277189	277031	277508
Mist green	73	277191	277032	277500
Pearl white	79	277343	277346	277510
Pearl white	79-1	277434	277346	277510
Graphite grey	80	277347	277350	277511
Graphite grey	80-1	277901	277350	277511
Desert sand	84	277447	277448	277512
Blue-green	85	277451	277452	None
Light blue	89	277548	277549	None
Dark blue	90	277552	277553	None
Light green	91	277905	277907	277513
Dark green	94	281061	281063	281064
Light blue	95	281073	281075	281076
Light blue	95-1	281143	281075	281076
Dark blue	96	281067	281069	281070
Yellow	97	281186	281191	281190
Grey	98	281192	281197	281196
Silver	Wheel Paint	None	None	277517
Silver	Wheel Paint	None	None	277516
Primer		None	None	277918