



CARS

Part 4 (46)
REAR AXLE
(Spicer)

**SERVICE
MANUAL**

CONTENTS

Specifications	1
Tools	2
Description	5
Repair Instructions	5
Work that can be carried out with the rear axle installed in the vehicle	5
Removing	12
Dismantling	12
Inspecting	14
Assembling	15
Installing	21
Fault Tracing	22
Illustrations	

SPECIFICATIONS

	23.	27	30 Volvo
Rear axle, type		Semi-floating	
Track width, 144	—	—	1315 mm (53 5/32")
P 120, P 210, PV 544, P 1800	1315 mm (51 49/64")	1315 mm (51 49/64")	1315 mm (51 49/64")
End play for drive shaft, 144	—	—	0.05—0.13 mm (0.0028")
P 120, P 210, PV 544, P 1800	0.07—0.20 mm (0.0028— 0.0080")	0.07—0.20 mm (0.0028— 0.0080")	0.07—0.20 mm (0.0028— 0.0080")

FINAL DRIVE

	Spiral bevel (hypoid)		
Type			
Reduction ratio	4.10: 1	4.10: 1	4.10: 1
alt.	4.56: 1	4.56: 1	4.56: 1
Run-out, crown wheel, max.	0.08 mm (0.0032")	0.08 mm (0.0032")	0.08 mm (0.0032")
Backlash	0.10—0.20 mm (0.0040— 0.0080")	0.10—0.20 mm (0.0040— 0.0080")	0.13—0.20 mm (0.0052— 0.0080")
Pre-loading on pinion bearings, new bearings	11—23 kgcm (9.5—20 lb.in.)	11—23 kgcm (9.5—20 lb.in.)	11—23 kgcm (9.5—20 lb.in.)
run- in bearings	6—11 kgcm (5—9.5 lb.in.)	6—11 kgcm (5—9.5 lb.in.)	6—11 kgcm (5—9.5 lb.in.)
Pre-loading on differential bearings	0.13—0.20 mm (0.0052— 0.0080")	0.13—0.20 mm (0.0052— 0.0080")	0.13—0.20 mm (0.0052— 0.0080")
Lubricant		Hypoid oil	
viscosity	SAE 80	SAE 80	SAE 80
Oil capacity	1.3 litres (2 1/4 Imp. pints=2 3/4 US pints)	1.3 litres (2 1/4 Imp. pints=2 3/4 US pints)	1.2 litres (2 1/8 Imp. pints=2 1/2 US pints)

TIGHTENING TORQUES

Flange	kgm	28—30	28—30	28—30
	lb.ft.	200—220	200—220	200—220
Caps	kgm	10—11	5.0—7.0	5.0—7.0
	lb.ft.	70—80	35—50	35—50
Crown wheel	kgm	5.5—7.0*	6.5—8.5	6.5—8.5
	lb.ft.	40—50	45—60	45—60
Inspection cover	kgm	2.0—3.5	2.0—3.5	2.0—3.5
	lb.ft.	15—25	15—25	15—25
Wheel nuts	kgm	10—14	10—14	10—14
	lb.ft.	70—100	70—100	70—100

* Thread 7/16"—20: kgm 7.0—8.5=lb.ft. 50—60.

SPECIAL TOOLS

FINAL DRIVE

The following tools are used for repair work on and adjustment of the final drive. Some of the tools listed under the heading "Drive Shaft" are also required for removal and fitting of the brake drums and drive shafts.

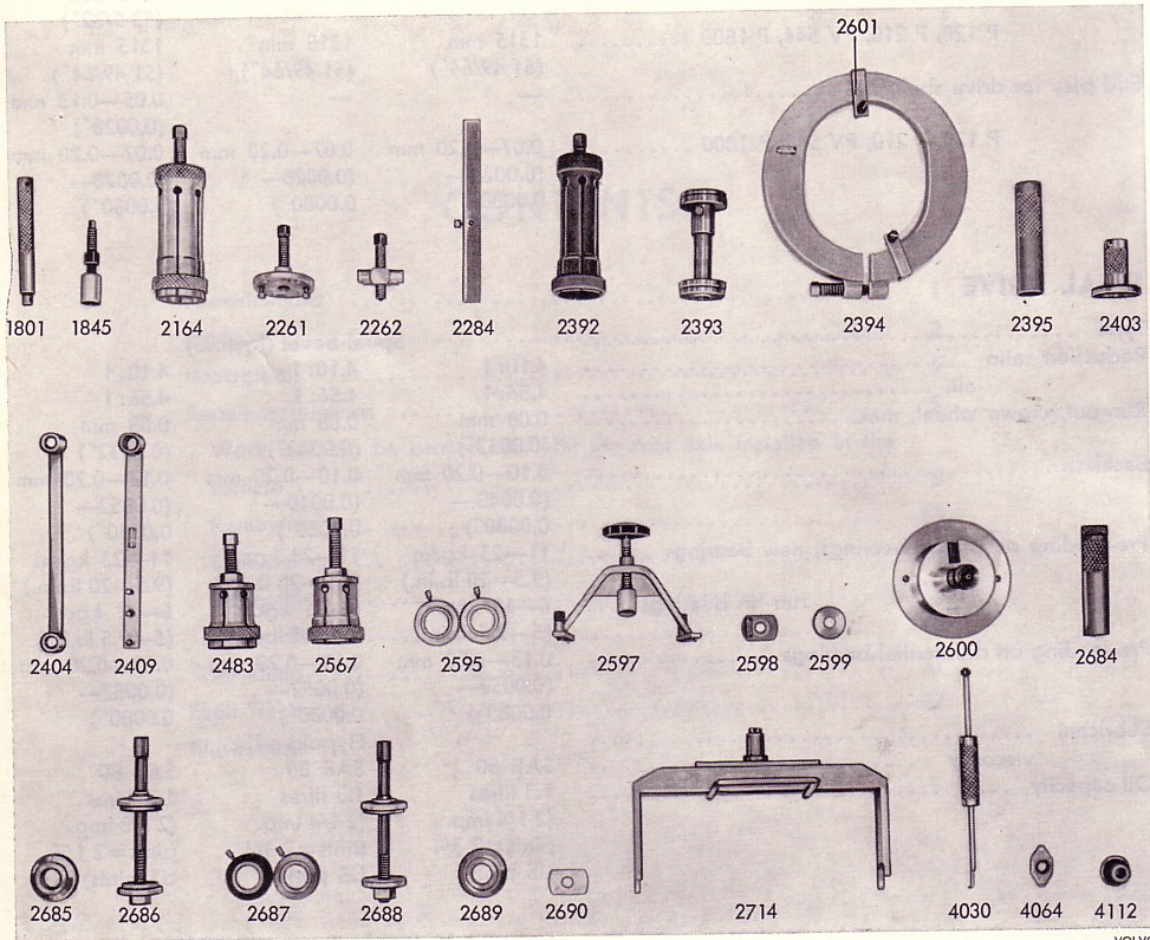

Fig. 1. Special tools for final drive unit

SVO No.	Description	Used for	
		23	27, 30
1801	Standard handle 18×200 mm	×	×
1845	Press tool for fitting flange	×	×
2164	Puller for rear pinion bearing	×	×
2261	Puller for round flange	×	×
2262	Puller for u-flange	×	×
2284	Retainer for indicator gauge for adjusting final drive	×	×
2392	Puller for rear pinion bearing	×	×
2393	Measuring tool for adjusting pinion	×	×
2394	Tensioning tool. Used for removing and fitting differential	×	×
2395	Sleeve for fitting inner ring, rear pinion bearing	×	×

SVO No.	Description	Used for	
		23	27, 30
2403	Drift for fitting oil seal at flange	×	×
2404	Spanner for fitting front pinion bearing	×	×
2409	Counterhold for flange	×	×
2483	Puller for differential carrier bearing		×
2520	Stand	×	×
2522	Fixture for rear axle (used together with stand 2520 for work on the final drive unit)	×	×
2567	Puller for differential carrier bearing	×	
2595	Adjusting rings for differential		×
2597	Brake for crown wheel. Used for checking tooth contact	×	×
2598	Drift for removing outer ring, rear pinion bearing		×
2599	Drift for removing outer ring, front pinion bearing		×
2600	Measuring fixture for adjusting rings	×	×
2601	Retainer for expander tool SVO 2394 (fitted on tool)	×	×
2684	Socket wrench for adjusting rings SVO 2685 and SVO 2689	×	×
2685	Adjusting ring for pinion	×	×
2686	Press tool for fitting outer rings, pinion bearing		×
2687	Adjusting rings for differential		
2688	Press tool for fitting outer rings, pinion bearing	×	
2689	Adjusting ring for pinion	×	
2690	Drift for removing outer ring, rear pinion bearing	×	
2714	Fixture for rear axle. Used on garage jack for removing and fitting rear axle	×	×
4030	Puller for oil seal at flange	×	
4064	Drift for removing outer ring, front pinion bearing	×	×
4112	Drift for fitting differential carrier bearing	×	×

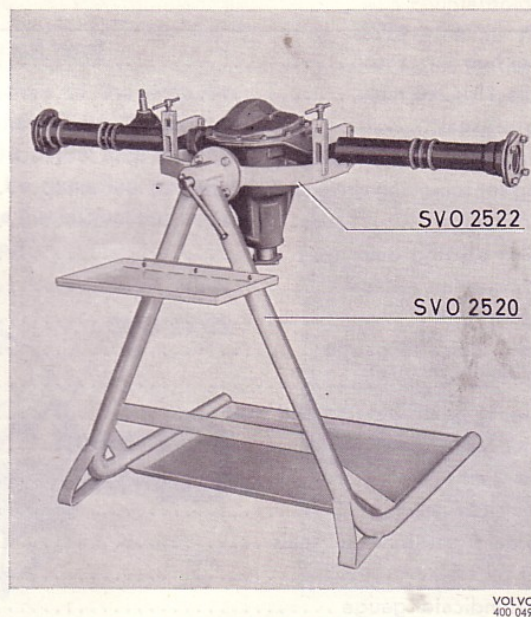

Fig. 2. Stand and fixture for rear axle

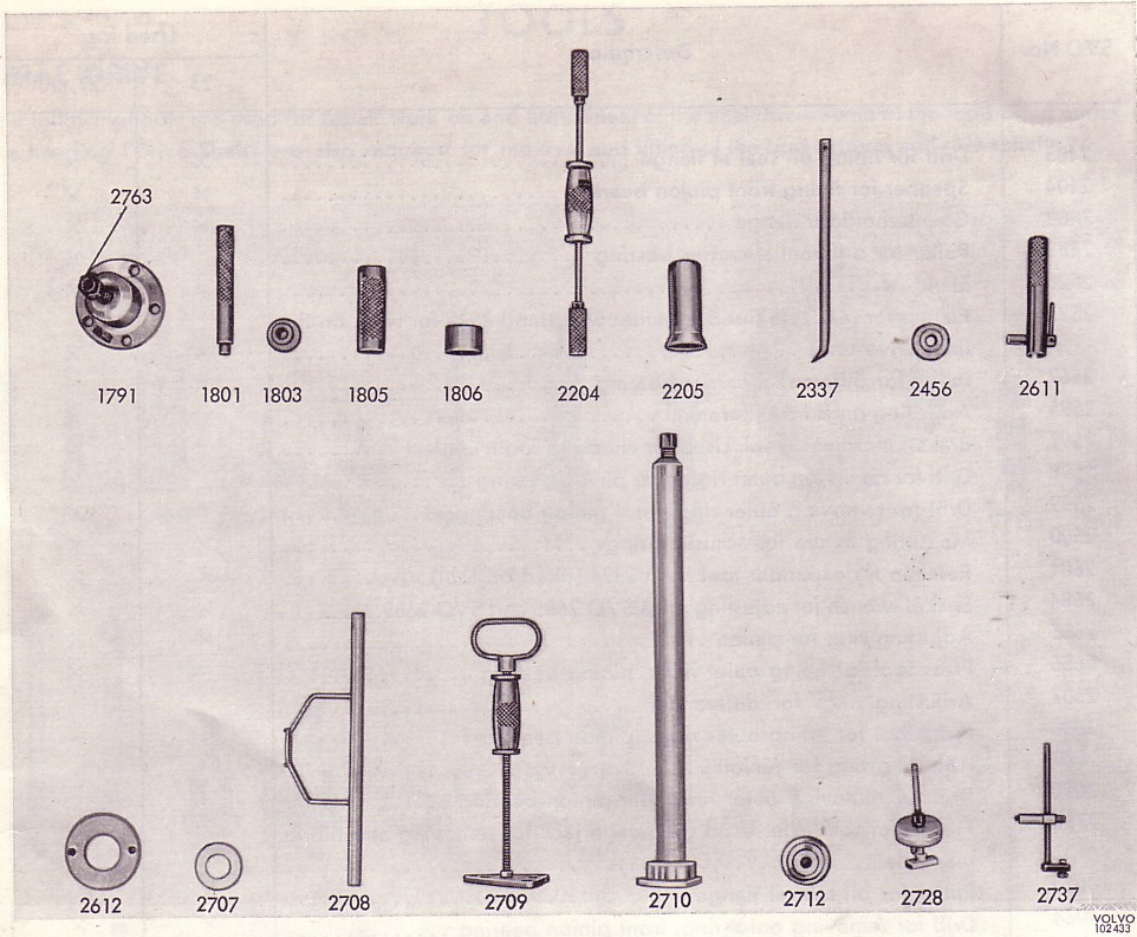

Fig. 3. Special tools for drive shaft

DRIVE SHAFT

SVO No.	Description	Used for	
		P 120, P 210 PV 544, P 1800	144
1791	Puller for wheel hub	×	
1801	Standard handle 18×200 mm	×	×
1803	Drift for fitting oil seal	×	
1805	Sleeve for fitting drive shaft bearing	×	
1806	Cushioning ring for removing drive shaft bearing	×	
2204	Puller for drive shaft	×	
2205	Sleeve for fitting bearing outer ring	×	
2337	Drift for removing outer oil seal		×
2456	Drift for fitting oil seal	×	
2611	Retainer for dial indicator gauge	×	
2612	Plate	×	
2707	Cushioning ring for fitting bearing and stop ring		×
2708	Tool for adjuster nut		×
2709	Puller for drive shaft		×
2710	Puller for drive shaft bearing		×
2712	Drift for fitting outer and inner oil seals		×
2728	Puller for inner oil seal	×	×
2737	Retainer for dial indicator gauge		×
2763	Spindle for supplementing puller VO 1791, so that nut puller can be used. (In the figure, fitted in SVO 1791.)	×	

DESCRIPTION

The different types of rear axles described in this manual are similar in design but differ somewhat concerning size and certain minor details.

The different types are:

Salisbury

Spicer 23

Spicer 27 (Hayes, Dana)

Spicer 30 (Hayes, Dana)

Volvo 1030

The Salisbury axles are installed only in the P 210 and P 120 Station Wagon.

The Hayes axles are similar to the Spicer 27 and 30 type axles.

From the point of view of repairs, the axles can be divided up into three groups:

Salisbury and Spicer 23

Spicer 27

Spicer 30 and Volvo 1030

The final drive (see Illustration A) is of the hypoid type, that is, the drive pinion lies below the centre of the crown wheel. It consists of the drive pinion, crown wheel and differential gears. The gear backlash and differential carrier bearing tension are adjusted by means of shims inside the differential carrier bearings.

The differential carrier and the crown wheel are journalled in the final drive housing by means of two taper roller bearings. The crown wheel is attached to the differential carrier by means of bolts. The differential gears themselves in the differential carrier consist of two bevel pinions on trunnions and two side gears in which the drive shafts are carried by internal splines. The differential gears are journalled so that they can rotate and permit the drive shafts to rotate at different speeds when the car is being driven round bends. A thrust washer is to be found under each of the differential gears.

The drive pinion is carried in taper roller bearings. The axial location of the drive pinion relative to the crown wheel is adjusted by shims under the outer ring of the rear pinion bearing. The pinion bearings are adjusted by means of shims under the front pinion bearing inner ring.

On the Volvo axles, spacer washers are used instead of shims. The spacer washer for the drive pinion location is thus placed at the back of the rear bearing inner ring. On adjusting this type of final drive, replace the spacer washers with shims, which are fitted in the same way as for the other types of final drives.

REPAIR INSTRUCTIONS

WORK THAT CAN BE CARRIED OUT WITH THE REAR AXLE INSTALLED IN THE VEHICLE

Replacement of pinion oil seal

1. Disconnect the rear section of the propeller shaft from the flange (yoke) on the pinion. Check for looseness of the pinion in its bearing. If it is loose, this must be remedied before a new oil seal is fitted. See the instructions under the heading "Assembling".

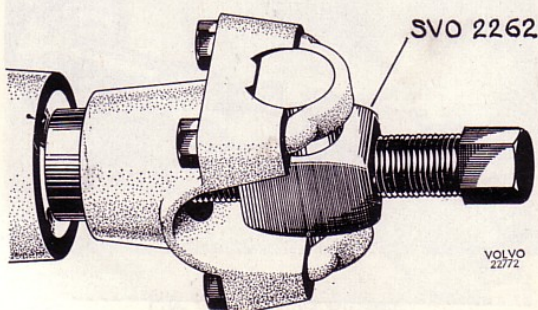

Fig. 4. Removing flange

2. Remove the flange nut by using lever SVO 2409 as a counterhold. Pull off the flange with tool SVO 2262 for the u-flange (Fig. 4) and tool SVO 2261 for the round flange (Fig. 5). Remove the old oil seal by using tool SVO 4030 as shown in Fig. 6.

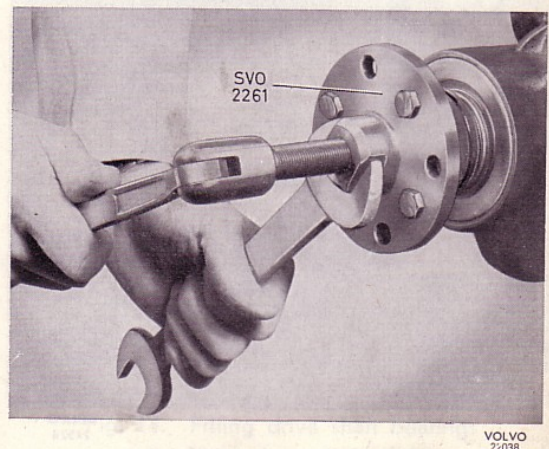

Fig. 5. Removing flange

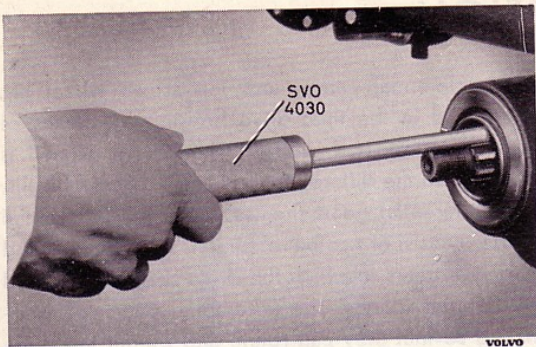

Fig. 6. Removing oil seal

3. Fit the new oil seal with tool SVO 2403, see Fig. 7.
4. Press on the flange with the help of press tool SVO 1845, see Fig. 8. Fit the washer and nut. Tighten the nut to a torque of 28—30 kgm (200—220 lb.ft.).
5. Re-connect the rear section of the propeller shaft.

P 120, P 210, PV 544, P 1800

REPLACEMENT OF DRIVE SHAFT OIL SEAL

1. Remove the wheel and pull off the wheel hub, see Fig. 9. Use puller SVO 1791. If the handle for puller SVO 1791 can be replaced by spindle SVO 2763, which is sold separately, the nut remover can be used for removing the hub. Remove the brake backing plate after having placed a wooden block under the brake pedal and loosened the brake lining on the backing plate.

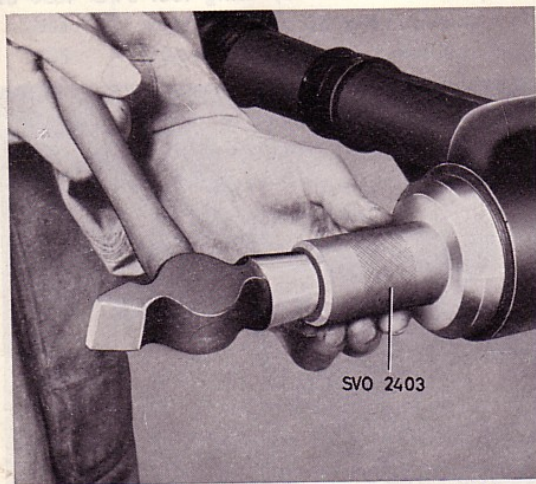

Fig. 7. Fitting oil seal

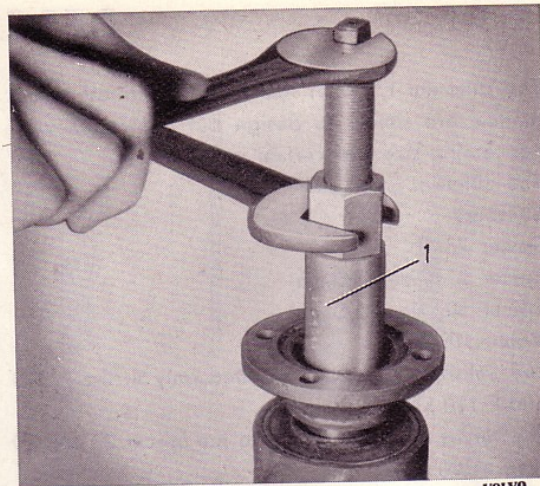

Fig. 8. Fitting flange
1. Press tool SVO 1845

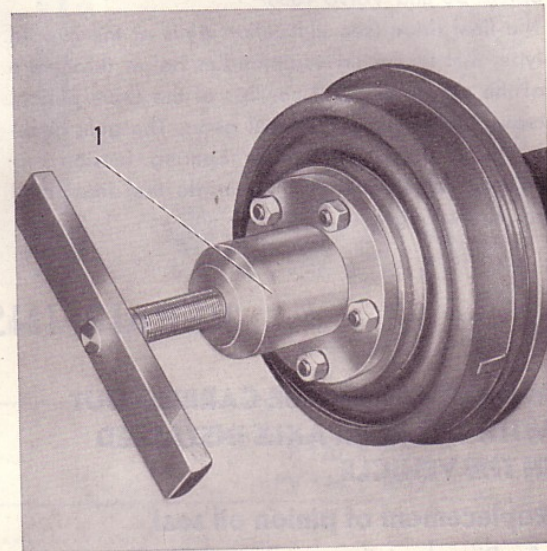

Fig. 9. Removing wheel hub
1. Puller SVO 1791

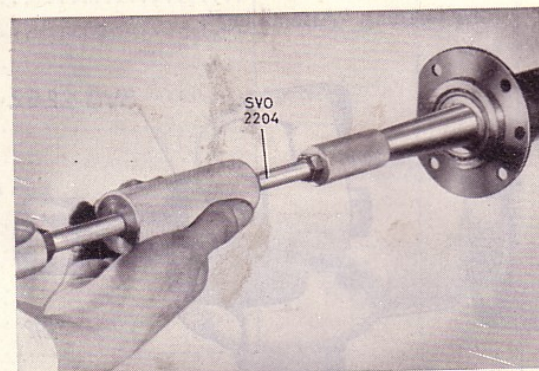

Fig. 10. Removing drive shaft

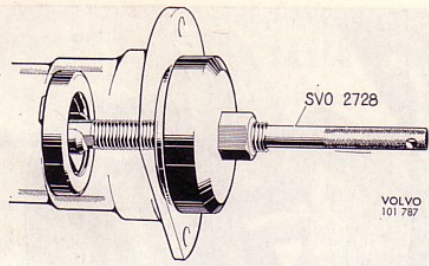

Fig. 11. Removing oil seal

2. Pull out the drive shaft, see Fig. 10. Use puller SVO 2204.
3. Pull out the oil seal with the help of tool SVO 2728, see Fig. 11.
4. Drive in the new oil seal. Make sure that it is driven in correctly. Use tools SVO 1801 and SVO 2456, see Fig. 12.
5. If necessary, clean the brake backing plate of any oil and grease. Replace brake linings if they have any oil or grease on them.
6. Fit the drive shaft and brake backing plate with a new felt washer.
7. Check the drive shaft end play. See point 5 under the heading "Replacement of drive shaft or bearing".
8. Replace the draw key if it has been removed and then fit the hub and wheel.
9. Vent and adjust the rear wheel brakes. Follow the instructions given in Part 5 "Brakes".
10. Check the oil level in the final drive.

REPLACEMENT OF DRIVE SHAFT OR BEARING

1. Remove the wheel and pull off the hub, see Fig. 9. Use puller SVO 1791. Remove the brake backing plate after having placed a wooden

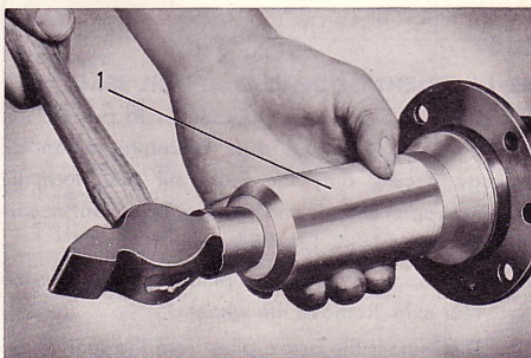

Fig. 12. Fitting oil seal
1. Drift SVO 2456

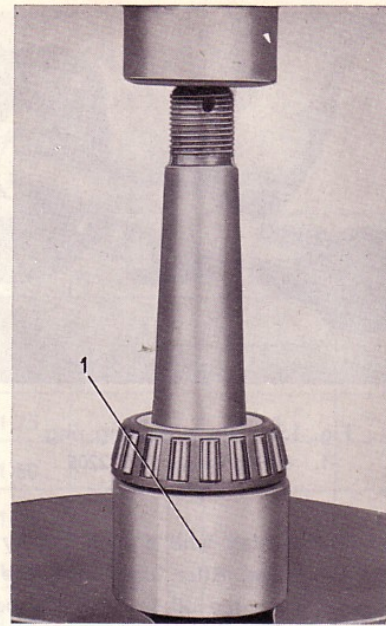

Fig. 13. Removing drive shaft bearings
1. Cushioning ring SVO 1806

- block under the brake pedal and loosened the brake line from the backing plate.
2. Pull out the drive shaft, see Fig. 10. Use tool SVO 2204. Check and, if necessary, replace the oil seal.
3. Press off the bearing, see Fig. 13. Use tool SVO 1806 under the bearing. Fit the new bearing with the help of sleeve SVO 1805, see Fig. 14.

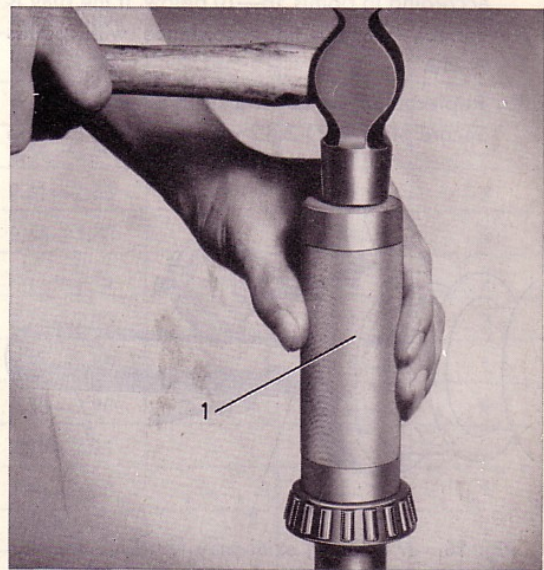

Fig. 14. Fitting drive shaft bearings
1. Fitting sleeve SVO 1805

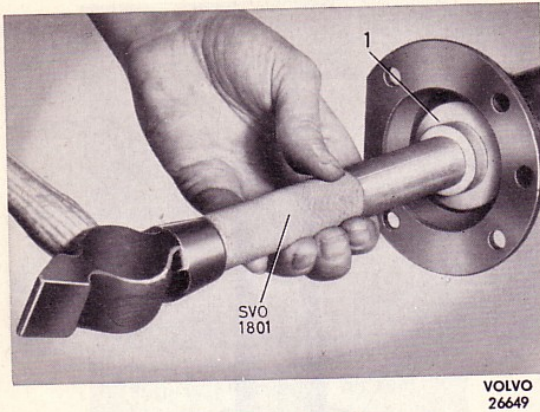

Fig. 15. Fitting bearing ring
1. Fitting sleeve SVO 2205

4. Pack the bearing with a high quality multi-purpose grease. After installation, the entire space between the oil seals should be filled with grease. Fit the drive shaft in the drive pinion carrier. Drive in the bearing outer ring with sleeve SVO 2205, see Fig. 15.
- 5a. Replacement of bearing on right-hand side:
Fit the brake backing plate and retainer with the felt seal. Pull the bearing outer ring out towards the brake backing plate with tool SVO 2204. Fit holder SVO 2611 securely with the dial indicator on the drive shaft. Set the indicator pointer facing the brake backing plate and measure the axial play. (Compare point 6 and Fig. 16.) If the play is incorrect, remove the brake drum on the left-hand side and also the brake backing plate. Then adjust the play according to points 5b—10 below. If the play is correct, proceed in accordance with points 7—10.
- 5b. Replacement of bearing on left-hand side:
Secure plate SVO 2612 with two bolts. Pull the

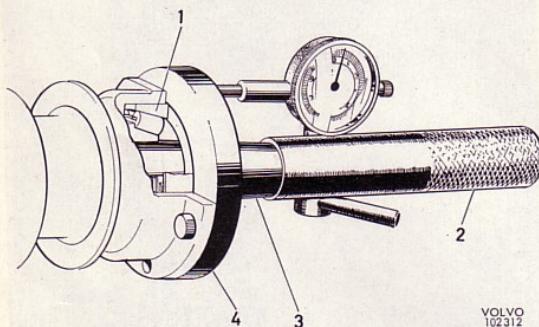

Fig. 16. Measuring axial play for drive shafts
1. Bearing outer ring
2. Holder SVO 2611 for dial indicator
3. Drive shaft
4. Plate SVO 2612

4—8

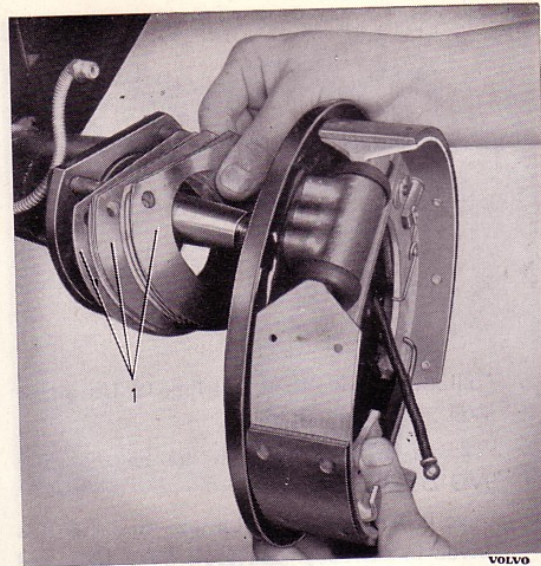

Fig. 17. Fitting brake backing plate
1. Adjuster shims

- bearing outer ring towards the plate with tool SVO 2204.
6. Fit the holder SVO 2611 with the dial indicator on the drive shaft, see Fig. 16. Aim the indicator pointer at the plate, move in the shaft and zero-set the indicator. Pull the drive shaft outwards and read off the play. To adjust to the correct play, select the size of shim according to the table on the next page.
7. Fit the brake backing plate together with the shims (left-hand side) and the retainer with the felt seal.
8. Fit the brake line as well as the hub, brake drum and wheel.
9. Vent the brake line and adjust the brake. Follow the instructions given in Part 5, "Brakes".
10. Check the oil level in the rear axle.

144

REPLACEMENT OF DRIVE SHAFT OIL SEALS

The purpose of the outer oil seal is to protect the bearing from dust and dirt. Therefore, when oil leakage occurs, only the inner oil seal normally requires replacement, and this is carried out according to points 1—4, 12—15 below.

1. Jack up the vehicle and place blocks under the rear axle. Remove the wheel.
2. Disconnect the brake pipe from the rear wheel brake unit. Slacken the bolts and remove the rear wheel brake unit. Unscrew the bolts for the brake disc and remove the disc.

TABLE FOR SELECTION OF SHIMS
Axial clearance 0.05—0.15 mm (0.0019—0.0059")

Read off clearance	Number of shims			Read off clearance	Number of shims		
	Th.=1.00 mm	Th.=0.35 mm	Th.=0.10 mm		Th.=1.00 mm	Th.=0.35 mm	Th.=0.10 mm
0.00—0.05	2	3	2	1.61—1.65	1	1	3
0.06—0.10	2	3	2	1.66—1.70	—	4	2
0.11—0.15	2	3	1	1.71—1.75	1	1	2
0.16—0.20	2	2	4	1.76—1.80	—	4	1
0.21—0.25	2	3	—	1.81—1.85	1	1	1
0.26—0.30	2	2	3	1.86—1.90	1	—	4
0.31—0.35	2	2	3	1.91—1.95	—	3	3
0.36—0.40	2	2	2	1.96—2.00	—	3	3
0.41—0.45	2	2	2	2.01—2.05	—	3	2
0.46—0.50	1	4	4	2.06—2.10	—	3	2
0.51—0.55	2	1	4	2.11—2.15	—	3	1
0.56—0.60	1	4	3	2.16—2.20	—	1	4
0.61—0.65	2	1	3	2.21—2.25	—	3	—
0.66—0.70	1	4	2	2.26—2.30	—	2	3
0.71—0.75	2	1	2	2.31—2.35	—	2	3
0.76—0.80	1	4	1	2.36—2.40	—	2	2
0.81—0.85	1	3	4	2.41—2.45	—	2	2
0.86—0.90	2	1	1	2.46—2.50	—	2	1
0.91—0.95	1	3	3	2.51—2.55	—	1	4
0.96—1.00	1	3	3	2.56—2.60	—	2	—
1.01—1.05	1	3	2	2.61—2.65	—	1	3
1.06—1.10	1	3	2	2.66—2.70	—	1	3
1.11—1.15	1	3	1	2.71—2.75	—	1	2
1.16—1.20	1	2	4	2.76—2.80	—	1	2
1.21—1.25	1	3	—	2.81—2.85	—	1	1
1.26—1.30	1	2	3	2.86—2.90	—	—	4
1.31—1.35	1	2	3	2.91—2.95	—	1	—
1.36—1.40	1	2	2	2.96—3.00	—	—	3
1.41—1.45	1	2	2	3.01—3.05	—	—	3
1.46—1.50	1	2	1	3.06—3.10	—	—	2
1.51—1.55	1	1	4	3.11—3.15	—	—	2
1.56—1.60	—	4	3	3.16—3.20	—	—	1

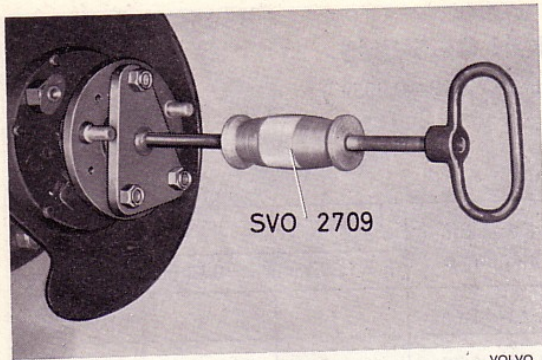

Fig. 18. Removing drive shaft

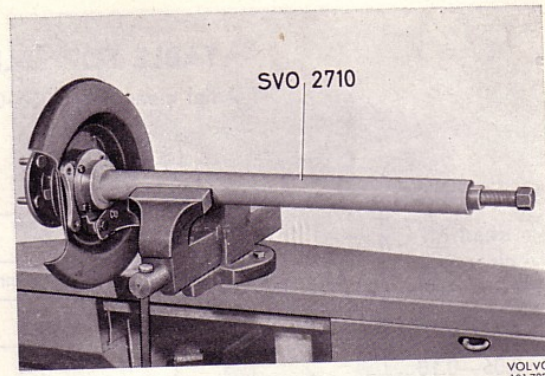

Fig. 20. Removing drive shaft bearing

3. Remove the return springs for the brake shoes and lift off the shoes. Disconnect the handbrake cable from the bracket and the lever. Remove the lever and cable.
4. Unscrew the bolts for the brake backing plate and retainers. These are loosened through the hole in the drive shaft flange (yoke). Turn the brake backing plate backwards so that the handbrake bracket runs free from the flange on the drive pinion carrier. Pull out the drive shaft with puller SVO 2709, see Fig. 18.
5. Secure the drive shaft firmly in a vice so that the recess in the brake backing plate faces the rear jaw of the vice. Secure the lock ring.
6. Drill a 6 mm (1/4") hole in the lock ring as shown in Fig. 19. Do not drill so deep as to damage the shaft. Split the ring with a cold chisel. NOTE. Apply the chisel to the outer edge of the ring in order not to damage the bearing. Remove the shaft from the vice and take off the lock ring.
7. Secure tool SVO 2710 in the vice. Shove in the drive shaft and fit the attaching bolts for the brake backing plate and retainers. Pull loose the bearing with the puller, see Fig. 20. Then remove the brake backing plate and retainers.
8. Place tool SVO 2707 under the brake retainer and drive out the oil seal with drift SVO 2337.
9. Clean and check all the parts. Especially make sure that all drill filings have been removed in order to prevent damage to the bearing.
10. Drive the new oil seal into the brake retainer (adjusting nut) with drift SVO 2712, see Fig. 21. Fill the space between the lips of the oil seal with grease.
11. Fit the brake backing plate and retainer on the drive shaft. Place the lock ring and bearing in the cushioning ring SVO 2707. Insert the drive shaft and fit the assembly in a press. Press on the drive shaft until the bearing and lock ring are in position, see Fig. 22.
12. Pull out the inner oil seal with puller SVO 2728, see Fig. 11. Drive in the new seal with drift SVO 2712, which automatically locates the oil seal correctly in the drive pinion carrier, see Fig. 23. The oil seal, however, must not be driven in so far that it bottoms.

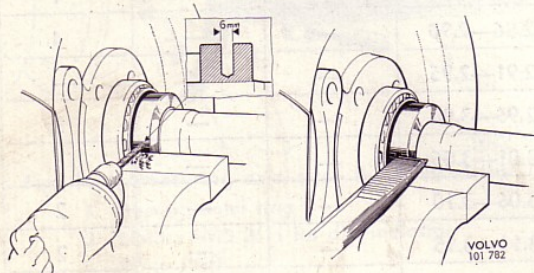

Fig. 19. Removing lock ring

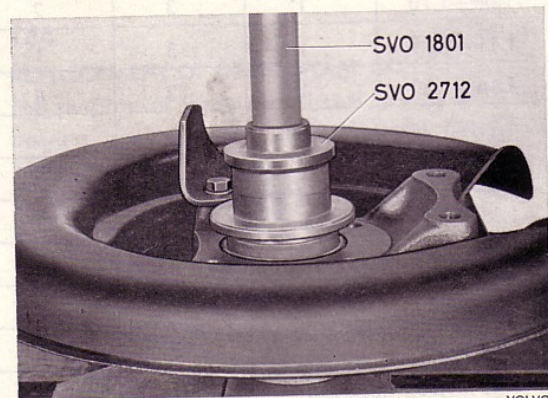

Fig. 21. Fitting outer oil seal

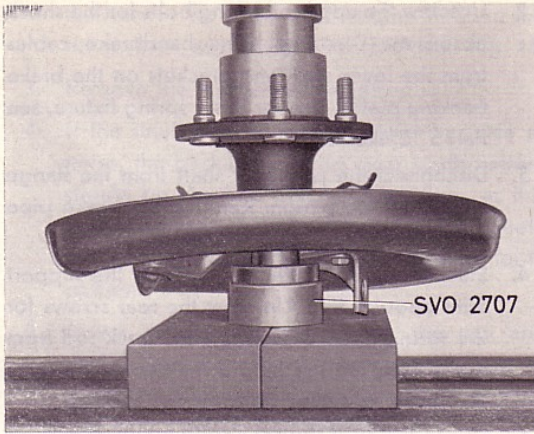

Fig. 22. Fitting drive shaft bearing

13. Pack the bearing well with a high-class, multi-purpose grease and then fit the drive shaft, brake backing plate and retainer. After installing, the entire space between the oil seal should be filled with grease, see Fig. 24. Check the axial play, which should be 0.05—0.13 mm (0.0020—0.0052"), with a dial indicator and holder SVO 2737, see Fig. 25. First, press out the outer rings in their bearings with the help

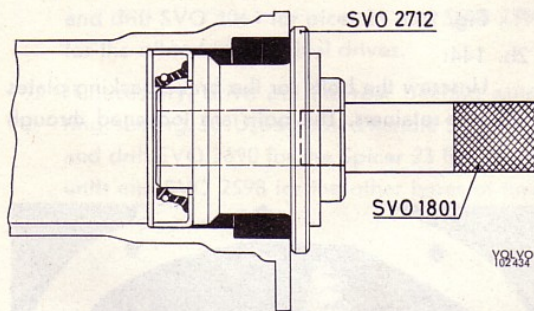

Fig. 23. Fitting inner oil seal

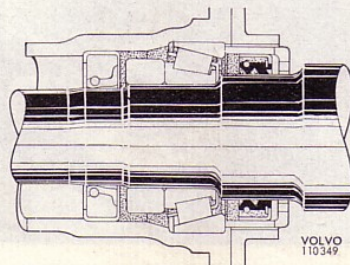

Fig. 24. Lubricating rear axle bearing

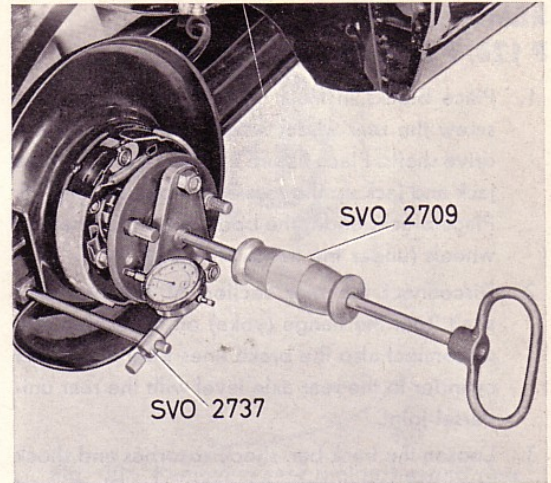

Fig. 25. Measuring axial play for drive shafts

- of a hammer on tool SVO 2709. If necessary, adjust. Use tool SVO 2708, see Fig. 26. Lock the adjuster nut with a suitable tab.
14. Fit the lever, handbrake shoes with spring and the adjusting device together with the handbrake cable. Then fit the brake disc and rear wheel brake unit. Connect up the brake line. Vent and adjust the brakes, see Part 5 "Brakes".
15. Fit the wheel and wheel nuts. Lower the vehicle and tighten the wheel nuts.

REPLACEMENT OF DRIVE SHAFT BEARING

On replacing the drive shaft bearing, follow points 1—7, 9, 11—15 in the description above.

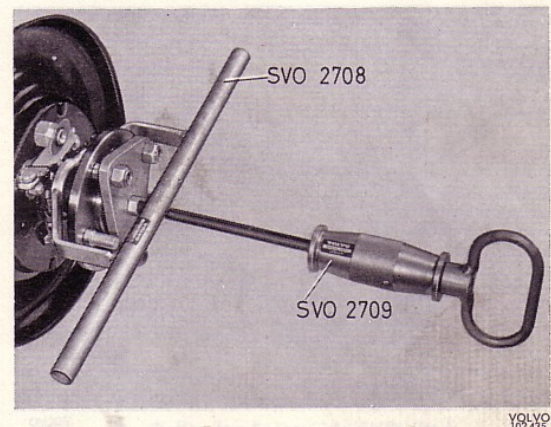

Fig. 26. Adjusting axial play for drive shafts

REMOVING**P 120, P 210, PV 544, P 1800**

1. Place blocks in front of the front wheels. Unscrew the rear wheel nuts and the nuts on the drive shafts. Place fixture SVO 2714 on a garage jack and jack up the rear end. Compare Fig. 55. Place blocks under the body in front of the rear wheels (under the frame on P 210).
2. Disconnect the rear section of the propeller shaft from the flange (yoke) on the pinion and disconnect also the brake lines from the master cylinder to the rear axle level with the rear universal joint.
3. Loosen the track bar, shock absorbers and shock absorber straps from the rear axle. Disconnect the handbrake cables and the adjuster.
- 4a. P 120, PV 544, P 1800:
Unscrew the nuts for the support arms. Lower the rear axle and remove the springs. Loosen the bolts for the torque rod and remove the rear axle.
- 4b. P 210:
Slacken the spring clamps and shackles. Lower the springs and remove the rear axle.

144

1. Place blocks in front of the front wheels. Unscrew the rear wheel nuts. Place fixture SVO 2714 on a garage jack and jack up the rear end of the vehicle. Compare Fig. 55. Place blocks in front of the rear jack attachments (see Fig. 27) and lower the jack slightly. Note that the blocks must not be placed further forwards than the dashed line indicated in the figure. Remove the rear wheels.

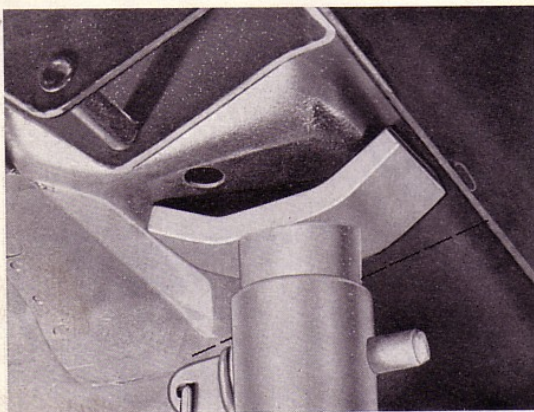

Fig. 27. Location of jack, 144

2. Unscrew the upper attaching bolts for the shock absorbers. Disconnect the handbrake cables from the lever arms and brackets on the brake backing plates. Use for this a spring fixture, see Part 5 "Brakes".
3. Disconnect the propeller shaft from the flange (yoke) on the pinion. Remove the brake pipe union from the final drive carrier.
4. Slacken the front attaching bolt for the support arms about 1 turn. Unscrew the rear screws for the torque rods. Disconnect the track rod from the bracket on the final drive carrier. Remove the lower attaching bolts for the springs.
5. Lower the jack until the support arms release from the springs. Unscrew the bolts securing the final drive carrier to the support arms. Lower the jack and pull the rear axle forwards.

DISMANTLING

1. Place the rear axle in fixture SVO 2522. The rear axle is placed with the underside of the final drive turned towards the bracket with the pinion pointing downwards. Remove the brake pipes.
- 2a. P 120, P 210, PV 544, P 1800:
Remove the brake backing plates from the final drive carrier. Take care of the shims. Pull out the drive shafts with puller SVO 2204, see Fig. 10.
- 2b. 144:
Unscrew the bolts for the brake backing plates and retainers. The bolts are loosened through

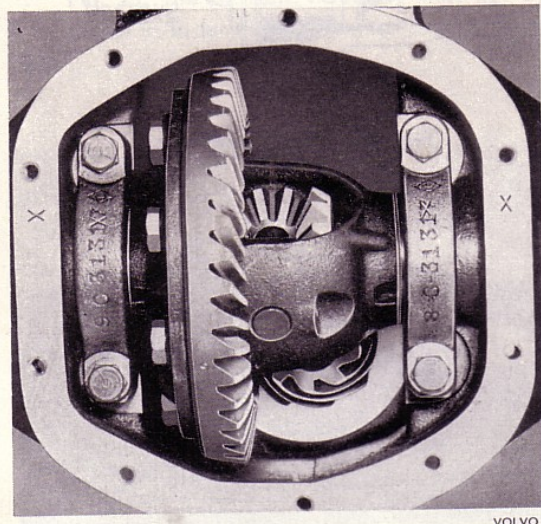

Fig. 28. Line-up marks on cap and carrier

the hole in the drive shaft flanges. Pull out the drive shafts with puller SVO 2709, see Fig. 18.

3. Remove the inspection cover.
4. If the final drive is reconditioned because of noise, the backlash and the gear tooth pattern should be checked before dismantling, as this may assist in fault tracing. First clean the teeth to avoid the possibility of misleading tooth pattern.
5. Check the line-up marking on the cap and carrier, see Fig. 28. If there are no line-up marks, or if they are difficult to see, mark one side with a punch. Remove the cap.
6. Fit tool SVO 2394 in the holes in the drive pinion carrier as shown in Fig. 29. Secure the tool with holders SVO 2601. Expand the tool until it fastens exactly in the holes on the carrier. Then tension the screw a further 3—3.5 turns. Lift out the differential carrier with crown wheel. Tool SVO 2337 can be used for this purpose.
7. Turn the final drive assembly and allow the oil to run out into a vessel. Remove the nuts for the flange. Use tool SVO 2409 as a counterhold. Pull the flange off with puller SVO 2261 for the round type flange and tool SVO 2262 for the small u-flange, see Figs. 4 and 5. Press out the pinion.
8. Drive out the front pinion bearing, the washer and oil seal with the standard handle SVO 1801 and drift SVO 4064 for picer 23 and SVO 2599 for the other types of final drives.
9. If necessary, drive out the rear bearing outer ring, see Fig. 30. Use standard handle SVO 1801 and drift SVO 2690 for the Spicer 23 final drive units and SVO 2598 for the other types of final drives.

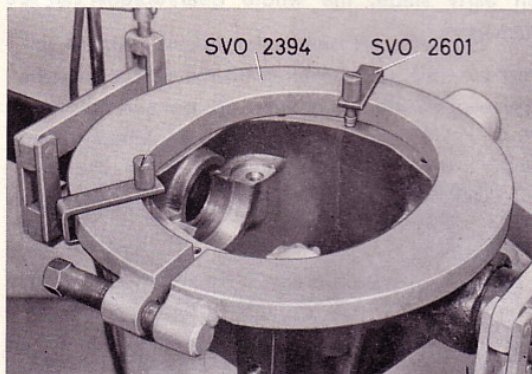

Fig. 29. Expanding drive pinion carrier

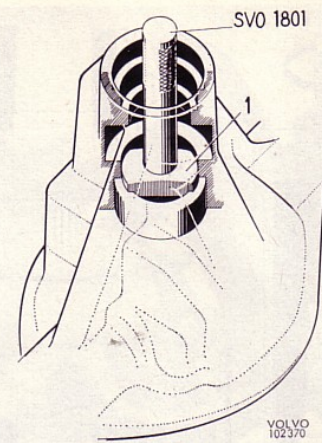

Fig. 30. Removing rear pinion bearing ring

1. Removal drift for Spicer 23: SVO 2690
Others: SVO 2598

10. Clean the gasket surface. Remove all burr with a file on those surfaces where the indicator holder SVO 2284 will slide.
11. If necessary, pull off the rear bearing from the pinion with puller SVO 2164 for the Spicer 23 final drives and SVO 2392 for the other types, see Fig. 31.
The puller is fitted in the following way:
Slide the puller down over the rollers and press down the lock ring. Then pull up the puller by means of the screw until the rollers are flush against the edge of the inner race and also the edge of the puller. Tap the lock ring with a hammer. See also Fig. 32.

Dismantling the differential

1. Loosen the crown wheel bolts and remove the crown wheel.

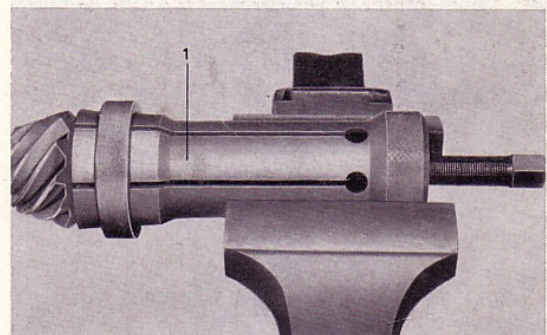

Fig. 31. Removing rear pinion bearing

1. Puller for Spicer 23: SVO 2164
Others: SVO 2392

P

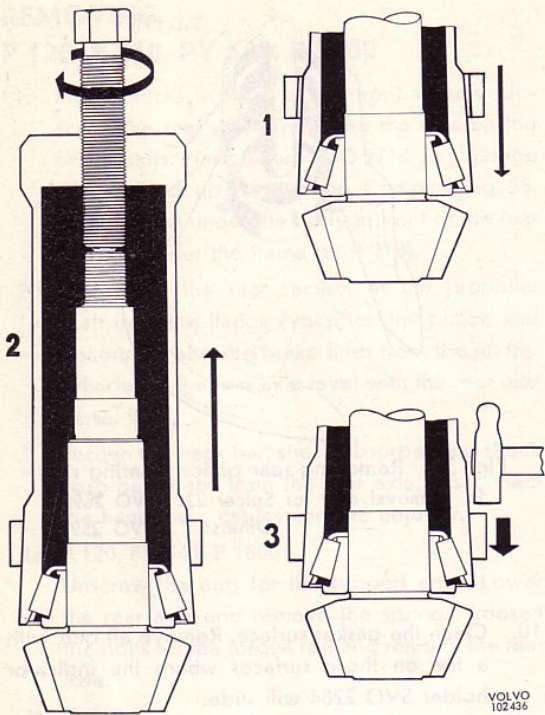

Fig. 32. Fitting puller

1. The puller is pressed down over the rollers
2. The rollers are pulled up
3. The lock ring is secured by tapping

VOLVO
102436

2. Drive out the lock pin, see Fig. 33, and then the shaft for the differential gears. Remove the thrust block, the differential gears and the thrust washers.



Fig. 33. Removing lock pin

VOLVO
23317

4—14

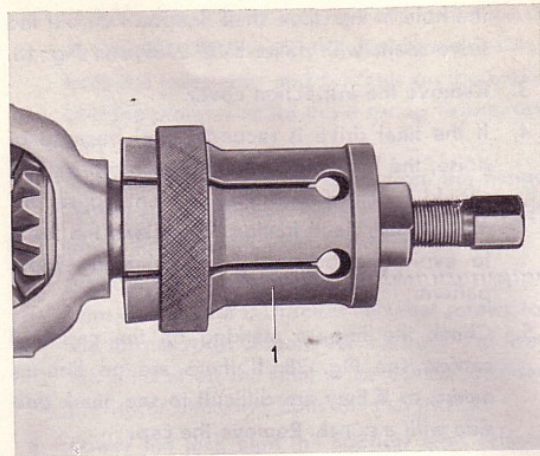

VOLVO
102371

Fig. 34. Removing differential carrier bearing

1. Puller for Spicer 23: SVO 2567
Others: SVO 2483

3. Remove the differential carrier bearings with puller SVO 2567 for the Spicer 23 final drive unit and SVO 2483 for the other types of final drives, see Fig. 34. Concerning fitting the puller, see also Fig. 32. Take care of the shims.

INSPECTING

First clean all the parts thoroughly. Check all the bearing races and bearings. The races, rollers or roller retainers must not be scratched or damaged. All damaged bearings and bearing races must be replaced.

Check both the pinion drive and crown wheel carefully for damage to the teeth. The most common damage is seizing gear teeth, see Figs. 35 and 36. This is caused by incorrect running-in, wrong oil, insufficient tooth flank clearance or faulty tooth contact. If the cause of the seizing is not remedied at an early stage, the whole gear wheel can be damaged.



VOLVO
102463

Fig. 35. Seizing tooth

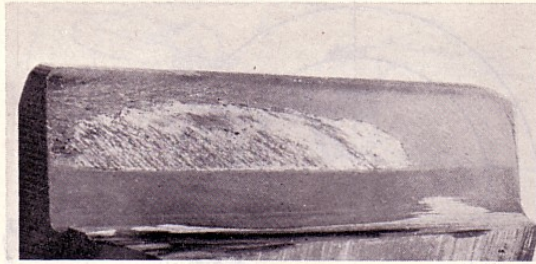

Fig. 36. Seizing tooth

The differential gears should also be examined for damage to the teeth. They should be fitted in a clean and dry condition in the differential carrier together with the shaft and thrust washers. Play should then be checked by means of marking blue behind both the differential side gears. If the play exceeds 0.06 mm (0.0024"), when the gears have been rotated to maximum play, replace with thicker washers. These are available in sizes 0.78 mm, 0.86 mm and 0.94 mm. Also check to see whether the cylindrical part of the flange which goes into the oil seal is worn or scratched. If so, replace the flange together with the oil seal.

The pinion nut is provided with a slit for locking. In time this slit loses its locking effectiveness. For this reason, the nut should be replaced if it has been removed a couple of times. The washer under the nut should also be replaced if it has become deformed.

Check the oil seals and replace them if they are damaged or worn.

Make sure that there are no cracks in the rear axle casing. Check that the brackets for the support arms and track rod are intact.

ASSEMBLING

The greatest cleanliness should be observed when assembling and adjusting final drives. Dirt in a tapered roller bearing can result in completely inaccurate measurement values.

On measuring the bearing clearance or pre-loading, the bearing should be oiled and rotated several turns loaded.

Assembling the differential

1. Place the differential side gears and the thrust washers in the differential carrier. Then "roll"

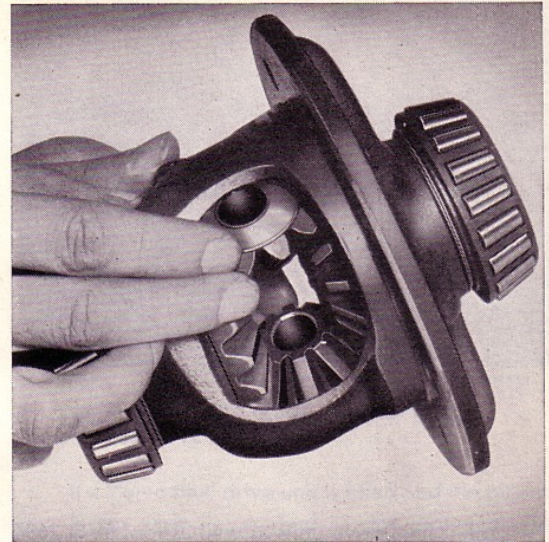

Fig. 37. Fitting the differential gears

in the differential pinions both simultaneously with the dished thrust washers, see Fig. 37.

2. Insert the thrust block and drive in the shaft.
3. Check the differential unit. If the gear play has not been measured, check it according to the instructions given under the heading "Inspecting". If oversize washers are fitted, this can be checked by turning the gears one turn. The requisite torque should not exceed 1 kgm (7.23 lb.ft.). The tool for making this check can be easily made from a shortened drive shaft which is adapted to a suitable torque wrench. After the checking and any replacement of the thrust washers, fit the lock pin.
4. Fit the crown wheel. Make sure that the contact surfaces are clean and without burr. Tighten the bolts. Concerning the tightening torque, see "Specifications".

NOTE. Always use new bolts for those gears where the bolts are locked only by means of friction in the thread and the contact surface of the screw head. To achieve the effect intended, the bolts are tightened to their limits. A certain permanent elasticity is thereby obtained in the bolt which becomes distorted for further fitting.

Fitting the pinion

1. Polish the marking surface on the pinion with very fine emery cloth. Set the adjusting ring SVO 2689 for Spicer 23 and SVO 2685 for the

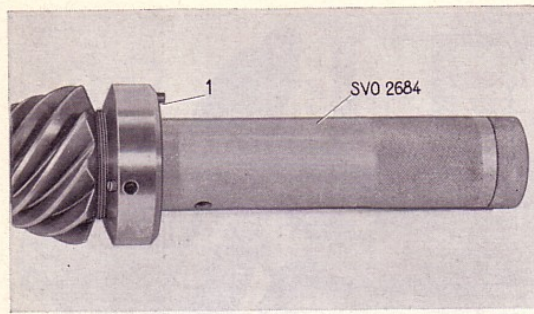

Fig. 38. Adjusting ring and socket wrench for pinion location

1. Puller for Spicer 23: SVO 2689
Others: SVO 2685

other final drive units as well as tool SVO 2684 on the pinion, see Fig. 38. Place the pinion in the casing so that the screw on the adjusting ring faces the larger part of the casing, see Fig. 39.

2. The pinion should have a certain nominal measurement (A, Fig. 40) to the centre line of the crown wheel. Due to tolerances in the manufacturing, there are deviations from the nominal measurement.

This is indicated on the ground surfaces on the pinion with a figure. Here there is an important difference between Volvo-manufactured and other types of rear axles.

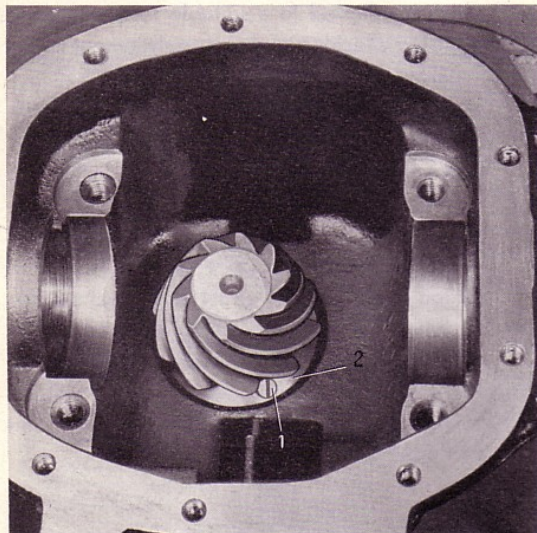

Fig. 39. Locating pinion with adjusting tool

1. Lock screw
2. Adjusting ring SVO 2685 or SVO 2689

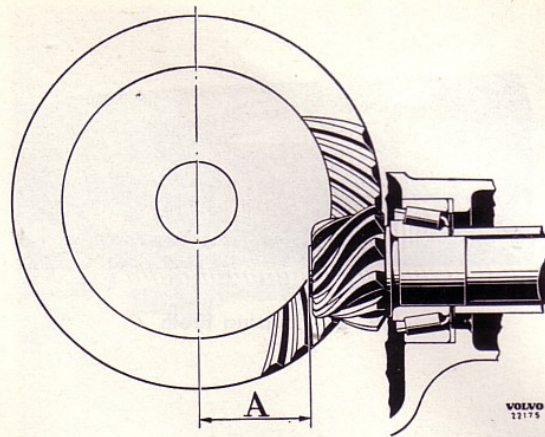

Fig. 40. Pinion location

A=Nominal measurement

On final drive units made by Volvo, the surface is generally ground down 0.30 (0.012") so that the deviation is always indicated by plus tolerance and in hundredths of a millimetre. The plus sign is excluded. On other final drive units, the deviation is indicated in thousandths of an inch and with plus or minus sign. If there is a plus sign in front of the figure, the nominal measurement is to be increased and, in the case of a minus sign, the nominal measurement is to be decreased.

Conversion table, inches to millimetres

inches	millimetres
0.001	0.025
0.002	0.051
0.003	0.076
0.004	0.102
0.005	0.127
0.006	0.152
0.007	0.178
0.008	0.203
0.009	0.229

To check the location of the pinion, use a dial indicator, indicator retainer SVO 2284 and a measuring tool SVO 2393, which consists of two parts: a pinion gauge and an adjuster fixture.

Checking is carried out in the following way: Place the pinion gauge on the ground end surface of the pinion and place the adjuster fixture in the differential bearing recesses as shown in Fig. 41. Note the different location for the different units. Place the indicator retainer on the drive pinion carrier and zero-set

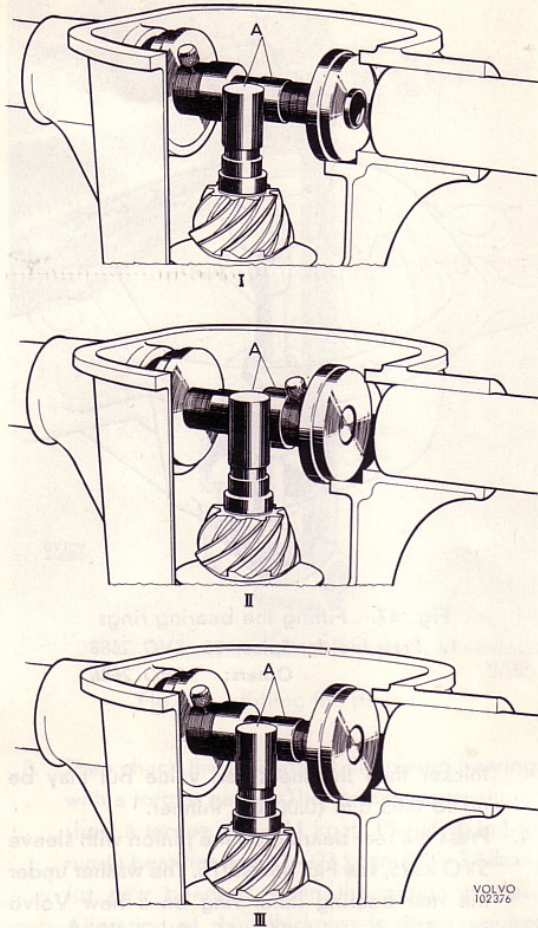

Fig. 41. Location of measuring tool
 A. Measuring tool SVO 2393
 I. Location of axle type Spicer 23
 II. Location of axle type Spicer 27
 III. Location of axle types Spicer 30 and Volvo

the indicator against the adjuster fixture, see Fig. 42. Then move over the indicator retainer so that the indicator is against the pinion gauge, see Fig. 43. Read off the indicator.

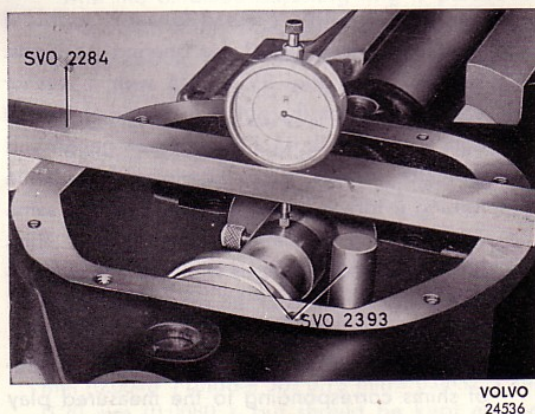

Fig. 42. Setting the indicator to zero

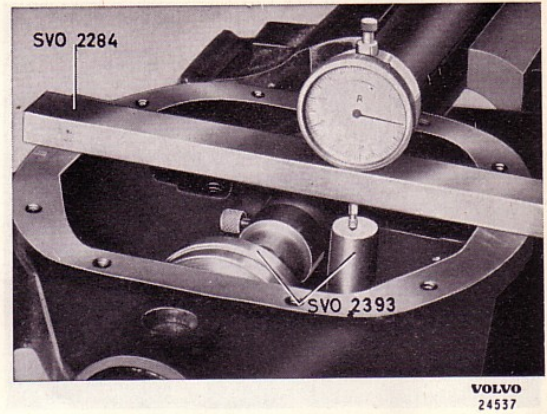

Fig. 43. Measuring the pinion location

If a Volvo final drive unit is fitted and the pinion is, for example, marked 33, the pinion gauge should lie 0.33 mm (0.013") under the adjuster fixture. Concerning the other final drive units, if the pinion is marked O, the adjuster fixture and pinion gauge should be at the same height; if the pinion is marked —, the pinion gauge should be higher than the adjuster fixture; and if it is marked +, the pinion gauge should be lower than the adjuster fixture with correct setting. The setting is adjusted by turning the cam on the pinion until the gauge dial shows the correct value. Then lock the adjusting ring with the lock screw. Remove the measuring tool and pinion.

- Place the rear pinion bearing complete with the outer ring in the measuring fixture SVO 2600. Fit on the plate, spring and nut. The flat side of the nut should face upwards. The plate (and thus the bearing) should be turned forwards and backwards several times so that the

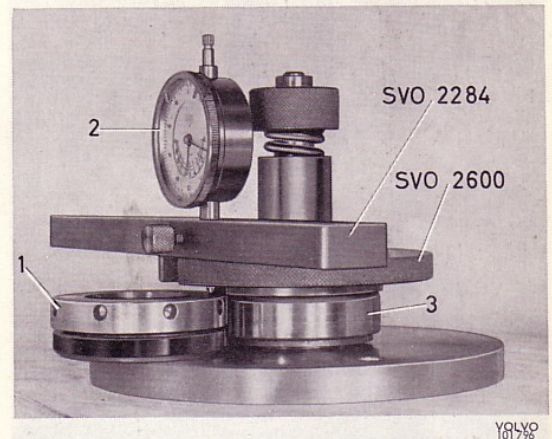

Fig. 44. Determining shim thickness

- Adjusting ring
- Measuring gauge
- Bearing complete

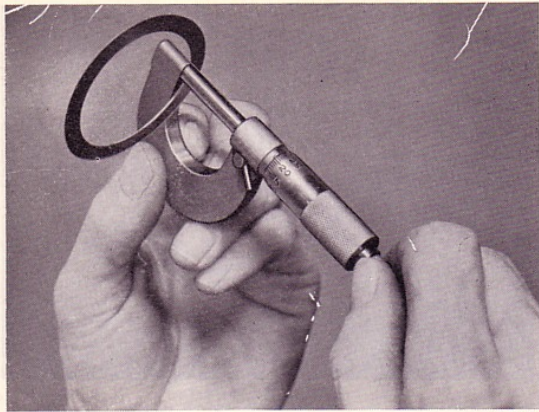

Fig. 45. Measuring the shims

rollers take up the correct position. Place the adjusting ring in the measuring fixture as shown in Fig. 44. Use indicator retainer SVO 2284 and a dial indicator. Place the measuring point of the gauge against the adjusting ring and set the gauge to zero. Then place the point of the gauge against the outer ring of the bearing. The gauge now shows immediately the requisite size for the shims. Measure the correct thickness of the shims with a micrometer, see Fig. 45. NOTE. It is not always possible to obtain shims with exactly the correct thickness. However, they must not be 0.03 mm (0.0012)

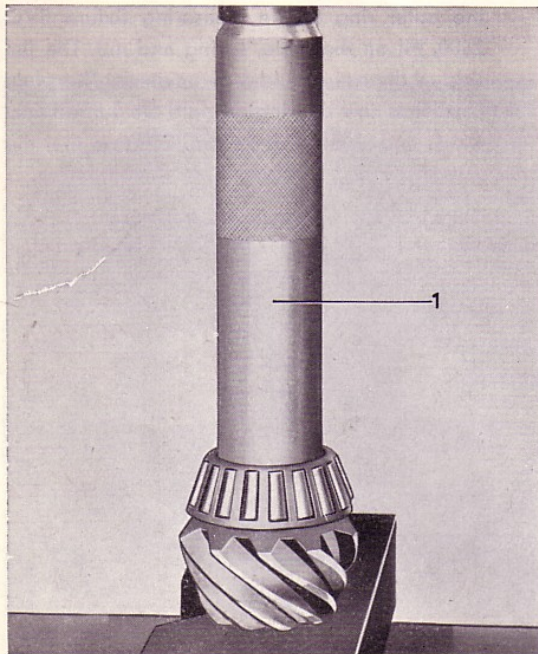

Fig. 46. Fitting the rear pinion bearing
1. Sleeve SVO 2395

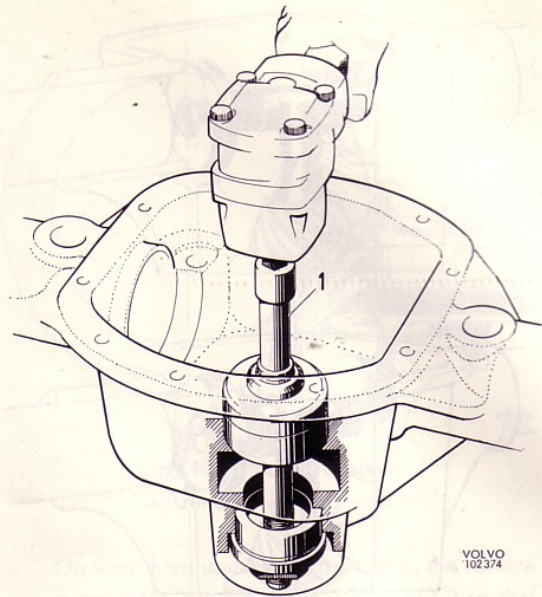

Fig. 47. Fitting the bearing rings
1. Press tool for Spicer 23: SVO 2688
Others: SVO 2686

thicker than the measured value but may be up to 0.05 mm (0.0020") thinner.

4. Press the rear bearing on the pinion with sleeve SVO 2395, see Fig. 46. NOTE. The washer under the rear bearing inner ring on a new Volvo final drive unit should **not** be fitted after reconditioning has been carried out. Fit the measured shims and press in both the outer rings of the bearings with tool SVO 2688 for the Spicer 23 unit and with tool SVO 2686 for the other final drive units, see Fig. 47.
5. Fit the pinion in the carrier and mount three 0.75 mm (0.30") thick shims and the front pinion bearing. Fit tool SVO 2404 and press tool SVO 1845 on the front end of the pinion and tighten the pinion, see Fig. 48.
If a nut remover is used when fitting the pinion, the pinion must be pressed forwards so that it does not strike against the bearing positions.
6. Replace press tool SVO 1845 with a washer and nut. Tighten the nut to a torque of 28—30 kgm (200—220 lb.ft.). Fit the pinion gauge and indicator retainer. Move the pinion down while turning it forwards and backwards at the same time. Set the indicator gauge to zero. Then press the pinion upwards while turning it backwards and forwards at the same time. Read off the play.
7. Remove the pinion. Remove a sufficient number of shims corresponding to the measured play +0.07 mm (0.0028"). Refit the pinion.

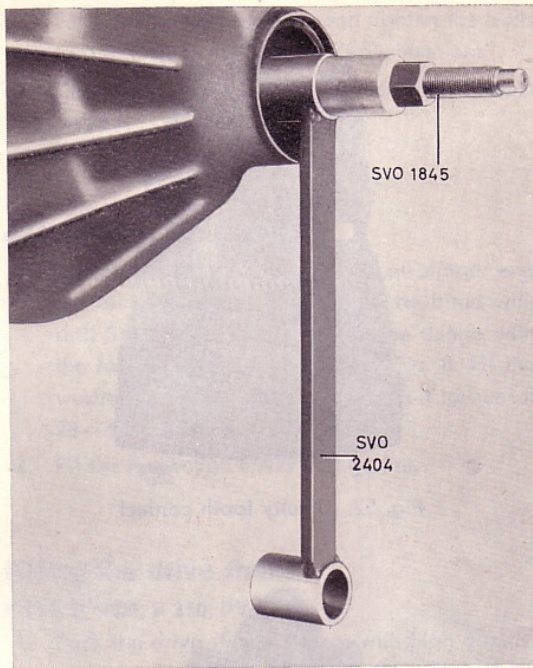

Fig. 48. Fitting the pinion

8. Then check the location of the pinion bearings with a torque gauge. The torque gauge should show a torque of 6—11 kgcm (5—10 lb.in.) for run-in bearings and 11—23 kgcm (10—20 lb.in.) for new bearings when the pinion rotates.* Alteration of shim thickness is often required due to the tolerances which must be present.
9. Check the location of the pinion with a dial indicator, indicator retainer SVO 2284 and measuring tool SVO 2393, see also point 2.

Fitting the differential

1. Oil the adjusting rings internally and fit them on the differential carrier. For the Spicer 23 unit, use adjusting rings SVO 2687 and for the other final drive units, use SVO 2595. The ring with the oxidized adjusting ring is placed on the crown wheel side. Oil also the bearing seat in the carrier. The differential carrier and adjusting rings are placed in the drive axle carrier, see Fig. 49. Use the dial indicator and adjust the ring so that the correct tooth flank clearance, 0.15 (0.0060") is obtained.** Tighten the lock bolts in the adjusting rings.

* On new final drive units, stresses can be higher due to another type of installation method. In other words, there is no fault.

** The tooth flank clearance may vary between 0.10 mm (0.0040") (model 30: 0.13 mm=0.0052") and 0.20 mm (0.0080"), but should be kept as near 0.15 mm (0.0060") as possible.

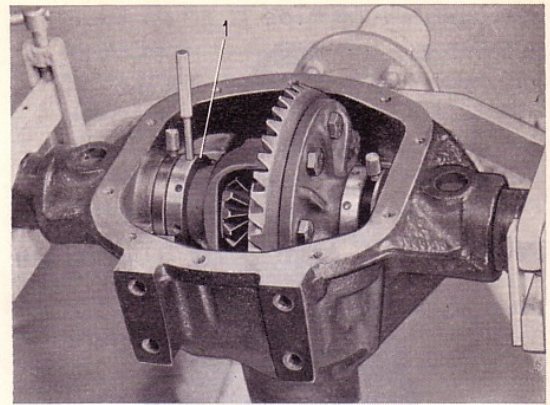

Fig. 49. Adjusting rings for differential
1. Adjusting rings for Spicer 23: SVO 2687
Others: SVO 2595

2. Fit on the brake tool SVO 2597 as shown in Fig. 50. Coat several teeth with marking blue at three points on the crown wheel. By this means a check can be kept on possible crown wheel warp. Pull round the pinion 10—12 turns in both directions and check the tooth pattern. When the tooth contact is correct, the contact pattern should be vertically in the middle of the tooth but somewhat nearer to the toe than to the heel. The contact pattern on the reverse side and driving side should lie opposite each other, see Fig. 51. If the contact pattern is incorrect, the location of the pinion must be adjusted before assembling continues. If the contact pattern lies too far towards the heel on the driving side and too far towards the toe on the reverse side, see Fig. 52, the pinion should be moved inwards. If the contact pattern lies too far towards the toe on the driving side and too far towards the heel on the reverse

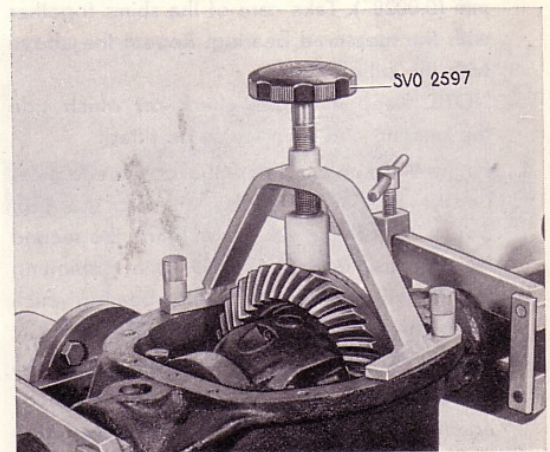

Fig. 50. Brake tool for differential

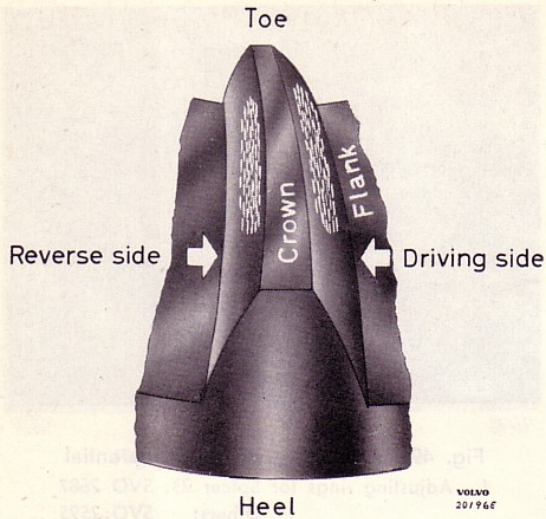

Fig. 51. Correct tooth contact

side, see Fig. 53, the pinion should be moved outwards. Note that the contact pattern will lie somewhat nearer the toe when the adjusting rings are fitted than when the bearings are fitted.

3. When correct tooth flank clearance and contact pattern are obtained, remove the differential and adjusting ring. Place the centre washer on the measuring fixture. Place a bearing in the measuring fixture and fit the plate, spring and nut. The nut should be fitted with the flat side facing downwards. Turn the plate forwards and backwards several times. Install the dial indicator gauge and retainer SVO 2284. Set the gauge to zero against the adjusting ring and then place the pointer facing the bearing, see Fig. 44. Read off the gauge. With a micrometer measure the shims the total thickness of which should correspond to the read-off value +0.07 mm (0.0028"). Take care of the shims together with the measured bearing. Repeat the above with the other bearing.

NOTE. Keep a careful check on which side the bearing and shim are to be fitted.

4. Fit the shims on the differential carrier and press on the bearings. For this purpose use drift SVO 4112, see Fig. 54. When fitting the second bearing, use drift SVO 2599 as a cushioning ring to avoid damage to the first bearing which has been pressed on.
5. Fit tool SVO 2394 on the drive shaft carrier, see Fig. 29. Extend the tool until the pins lie exactly against the hole edges in the carrier and then tighten the bolts a further 3—3.5 turns. Fit the differential and outer rings. Remove tool SVO

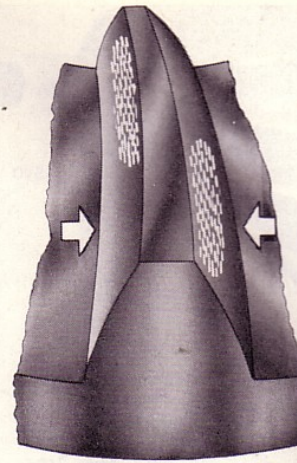

Fig. 52. Faulty tooth contact

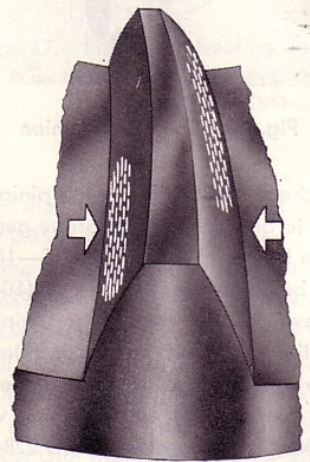

Fig. 53. Faulty tooth contact



Fig. 54. Fitting the differential carrier bearing

2394. Fit the bearing caps and tighten the bolts to the torque given in the "Specifications".
6. Check the tooth flank clearance and contact pattern.

Assembling the rear axle

1. Remove tool SVO 2404. Fit the oil slinger and the oil seal. The oil seal should be fitted with drift SVO 2403. Then press on the flange with the help of tool SVO 1845, see Fig. 8. Fit the washer and nut. Tighten the nut to a torque of 28—30 kgm (200—220 lb.ft.).
2. Fit the inspection cover and gasket.

Fitting the drive shafts

P 120, P 1800, P 210, PV 544

1. Pack the drive shaft bearings with high quality, multi-purpose grease and fit the drive shaft. Drive in the outer bearing rings with installation sleeve SVO 2205, see Fig. 15.
2. Fit the brake backing plate and felt seal on the right-hand side.
3. Fit plate SVO 2612 on the left-hand side with two screws. Tap several times with a hammer on both shaft ends so that the outer rings of the bearings locate in their extreme positions.
4. Secure retainer SVO 2611 on the drive shaft, see Fig. 16. Fit a dial indicator gauge and aim its point towards the plate. Shove the drive shaft inwards and set the gauge to zero. Pull the drive shaft outwards and read off the clearance. Select the shims required according to the table given on page 9.
5. Fit the brake backing plate on the left-hand side with the shims according to the table on page 9 and also the felt seal, see Fig. 17. Examine the rubber protection which seals with the handbrake cable in the brake backing plate. If necessary, replace it. Securely connect up the brake fluid line and brake cable at both sides. Fit the hub with the brake drums.

144

1. If the inner oil seals for the drive shafts are not fitted, they can be driven in with drift SVO 2712, see Fig. 23.
2. Pack the bearing well with high class, multi-purpose grease and then fit the drive shaft, brake backing plate and retainers. After installation has been carried out, the entire space between the oil seals should be filled with

grease, see Fig. 24. Check the axial play, which should be between 0.05—0.13 mm (0.0020—0.0052"), with the dial indicator gauge and indicator retainer SVO 2737, see Fig. 25. First press out the outer rings in their positions with the help of a hammer on tool SVO 2709. Adjust if necessary. Use for this purpose tool SVO 2708, see Fig. 26. Lock the adjuster nut with a suitable tab.

3. Fit the brake discs and the rear wheel brake units. Fit the brake pipes.

INSTALLING

P 120, P 1800, PV 544

1. Place the rear axle in fixture SVO 2714 on a jack. Lift up the rear axle and fit the torque rods. Slide the support arms into the retainers on the body and fit the rubber blocks, washers and nuts. The nuts should be tightened only a couple of turns to begin with.
2. Fit the springs, retainers and rubber blocks in position. Fit any bolts. Lift up the rear axle with the jack. Tighten the nuts for the support arms. Fit the shock absorbers, shock absorber straps and track rod.
3. Connect up the universal joint at the flange. Connect up the brake fluid hose. Connect up the handbrake cables. Vent the brake system and adjust the handbrake. Fill up with oil. Use only hypoid oil. **If the final drive unit is new, follow standard Mil 2105 B.**
4. Fit the wheels and wheel nuts. Lower the car and tighten the wheel nuts to a torque of 10—14 kgm (70—100 lb.ft.).

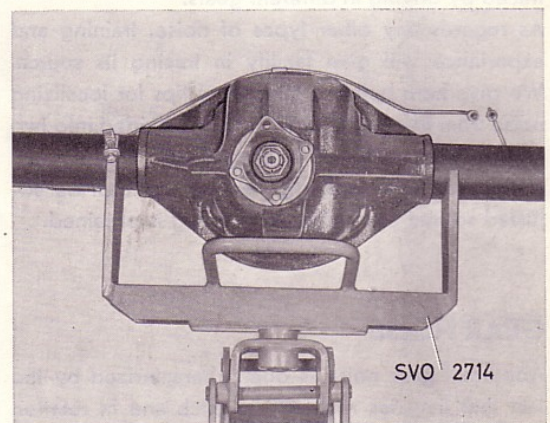

Fig. 55. Fixture for rear axle

P 210

1. Place the rear axle in fixture SVO 2714 on a jack. Lift up the rear axle. Lift up and fit the spring shackles. Fit the spring clamps and shock absorbers.
2. See points 3 and 4 above.

144

1. Place the rear axle in fixture SVO 2714 on a garage jack, see Fig. 55. Move the rear axle in under the car and fit on the bolts for the support arms and torque rods.
2. Raise the jack until the track rod attachment on

the shaft is at the level with the attachment on the body. Fit the track rod.

3. Fit the attaching bolts for the springs. Tighten the nuts for the torque rods and support arms.
4. Fit the bracket, screw union and brake hoses. Connect up the universal joint to the flange.
5. Fit the upper bolts for the shock absorbers. Fit the handbrake cable in the brackets and at the levers. Adjust the handbrake and vent the brake system, see Part 5. Fill up with oil.
6. Fit on the wheels and wheel nuts. Lower the car. Tighten the wheel nuts to a tightening torque of 10—14 kgm (70—100 lb.ft.). Fill up with oil. Use only hypoid oil. **If the final drive unit is new, follow standard Mil 2105 B.**

FAULT TRACING

When fault tracing, it should be remembered that a certain amount of noise is always produced by the rear axle and that this noise level reaches a maximum at a certain speed. This is a normal occurrence and should not require any attention. What should first be established is whether the noise is abnormal.

What also should be established is the source of the noise. Rear axle noise is often confused with noise from wheels, gearbox noise, resonance noise from the transmission, noise from propeller shafts and idler bearings, etc.

Wheel noise can often be traced by increasing the tyre pressure. If this changes the noise, then the tyre must be the source of the original abnormal noise. Gearbox noise can be traced by driving in different gears.

Certain resonance noise which follows the engine speed, for example, from the clutch, can also be traced by driving in different gears.

As regards any other types of noise, training and experience will give facility in tracing its source. We give here below a number of tips for localizing noise from the rear axle. This can be divided into two groups, gear noise and bearing noise.

NOTE. For all test driving, the engine must be adjusted so that the smoothest running is obtained.

GEAR NOISE

Abnormal gear noise is often characterized by the fact that it varies regularly in pitch and in relation to the speed. As a rule, it varies with the load and different driving conditions. For this reason, listen

to the differences in the sound when the engine drives the vehicle, when the engine neither drives nor is braked, and when the engine is braked.

BEARING NOISE

Faulty bearings produce a grinding or rattling noise which has a constant pitch and is heard most when the car is driven or when it runs with the engine disconnected and gearbox disengaged. The following three ways are recommended when tracing bearing noise.

1. Incorrect pinion bearings can be recognized by a constant hard noise. The pinion bearings rotate more rapidly than the differential and drive shaft bearings. Check the noise on a level stretch of a road at different speeds.
2. Differential bearing noise also produces a hard constant noise but at a lower frequency than the noise from pinion bearings. Drive the car on a level stretch of a road at varying speeds and swing from side to side of the road (watch the traffic). The noise from the differential bearings will remain constant under the driving conditions.
3. Faulty drive shaft bearings produce an uneven noise under driving conditions according to point 2 because of the heavy and varying loading when swinging the vehicle. To ascertain further which bearing is producing the abnormal noise, jack up both wheels, rotate one at a time and look for unevenness or jamming.

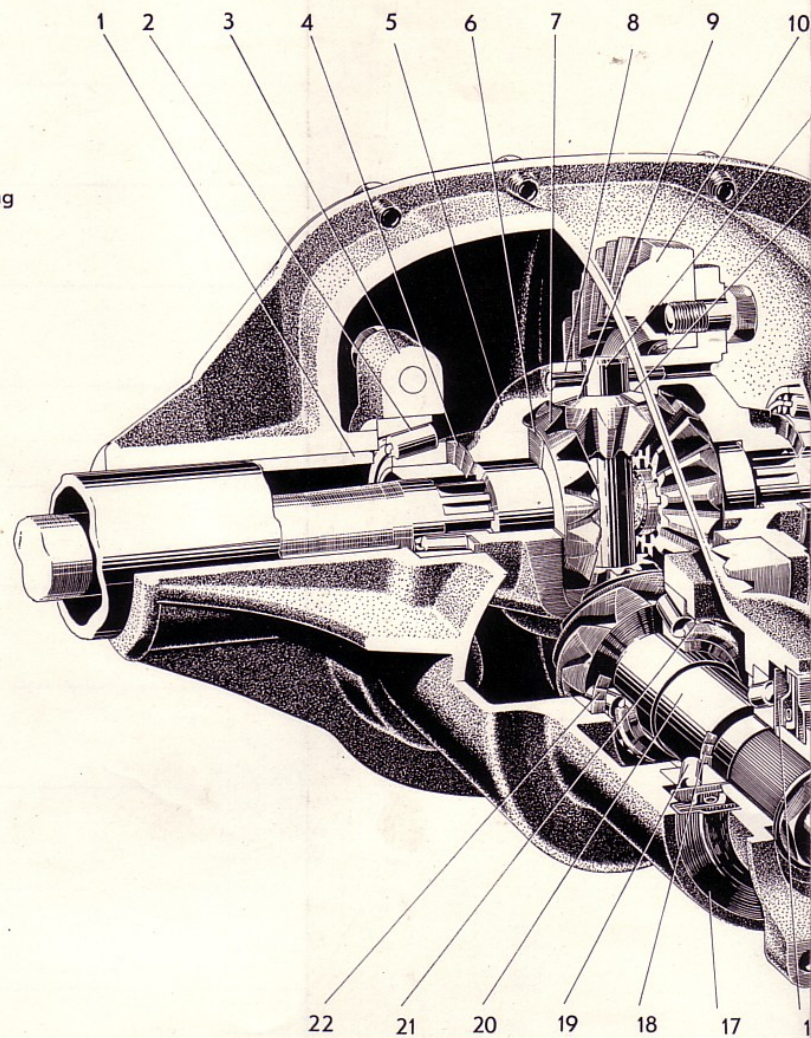

1. Tubular shaft
2. Differential carrier bearing
3. Bearing cap
4. Shims
5. Differential carrier
6. Thrust washer
7. Differential side gear
8. Lock pin
9. Differential pinion
10. Crown wheel
11. Shaft
12. Thrust washer
13. Drive pinion carrier
14. Flange
15. Dust cover plate
16. Oil slinger
17. Oil seal
18. Shims
19. Front pinion bearing
20. Pinion
21. Rear pinion bearing
22. Shims

Illustration A. Final drive

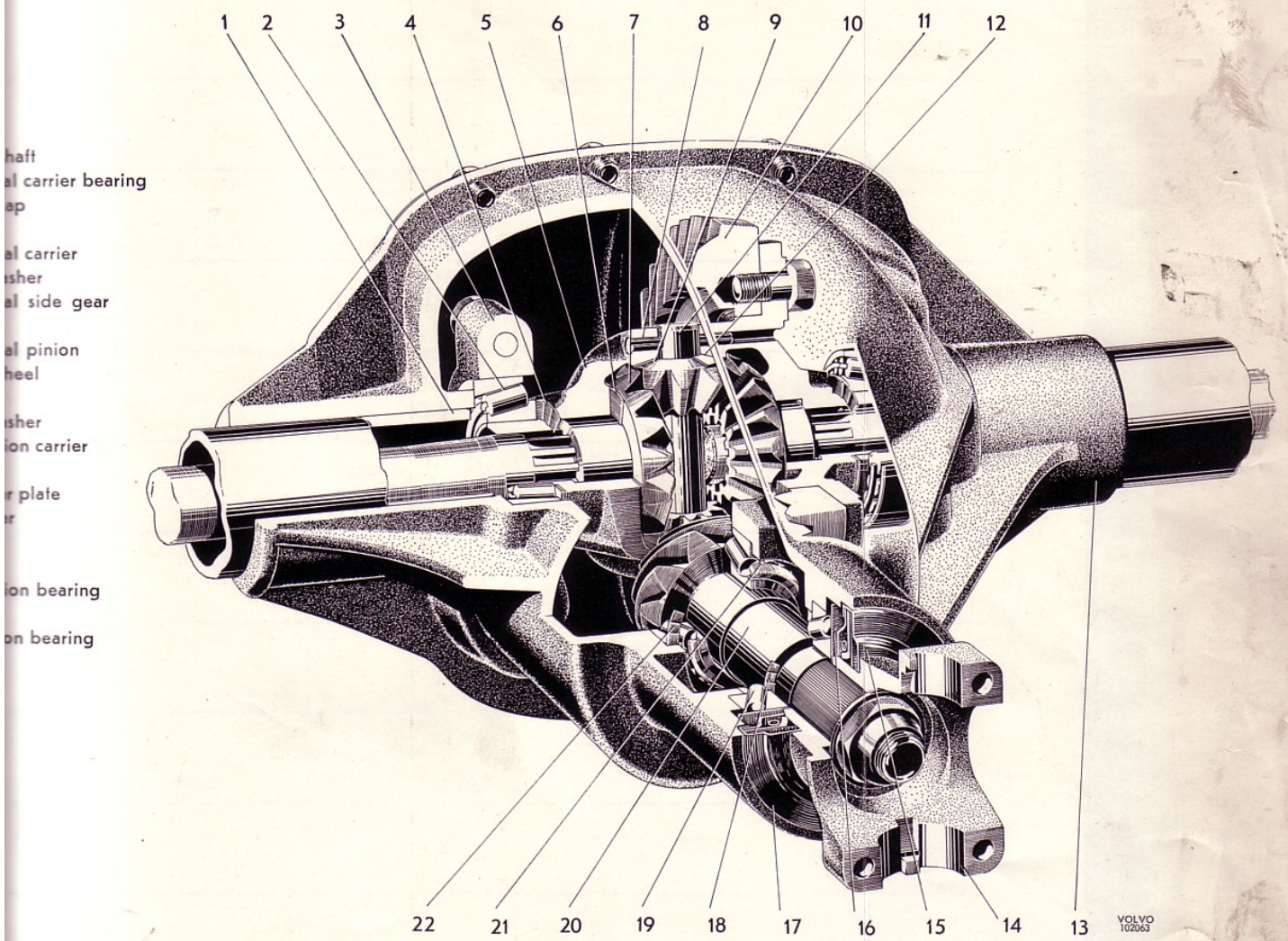
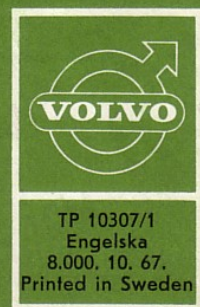

Illustration A. Final drive



Handelstryckeriet, Göteborg