

Section 8

**BODY**

# INDEX

<b>Group 80. General</b>		Tail gate, 145 .....	8:12
Tools .....	8:1	Sun roof .....	8:13
<b>Group 81. Body Frame</b>		<b>Group 84. Sealing Strips, Glass and External Trim Mouldings</b>	
General Information .....	8:2	Service Procedures .....	8:14
Service Procedures .....	8:4	Sealing strips .....	8:14
<b>Group 82. Hood and Mud Guards</b>		Trim mouldings .....	8:14
General Information .....	8:5	Windshield .....	8:15
Service Procedures .....	8:5	Rear windows .....	8:16
Front mud guards .....	8:5	Rear quarter windows .....	8:17
Front section .....	8:5	<b>Group 85. Upholstery, Interior Equipment and Heating System</b>	
Hood and hood lock .....	8:5	General Information .....	8:18
<b>Group 83. Doors and Trunk</b>		Seats .....	8:18
General Information .....	8:6	Door upholstery .....	8:19
Service Procedures .....	8:7	Headlining .....	8:19
Doors .....	8:7	Firewall and floor .....	8:19
Removing and installing door stops ..	8:7	Heating system .....	8:19
Removing inner handles and upholstery .....	8:7	Standard system .....	8:20
Removing and installing front doors ..	8:7	Combined system .....	8:21
Removing and installing rear doors ..	8:7	Service Procedures .....	8:25
Removing front door locks .....	8:8	Seats .....	8:25
Removing door handles .....	8:8	Headlining .....	8:28
Installing and adjusting front door handles .....	8:8	Instrument panel .....	8:28
Removing rear door locks .....	8:9	Heating system .....	8:30
Installing and adjusting rear door handles .....	8:9	Standard system .....	8:30
Striker plates .....	8:9	Combined system .....	8:32
Removing door windows .....	8:10	Cooling system (Air Conditioner .....	8:39
Removing window winders .....	8:11	<b>Group 86. Bumpers</b>	
Trunk lid, 142, 144 .....	8:11	Removing and installing .....	8:43
		Illustration 8-A. Control drawing for body floor	

# GROUP 80

## GENERAL TOOLS

The numbers for the tools may be preceded by 999 or SVO, e.g. 999 2739 or SVO 2739.

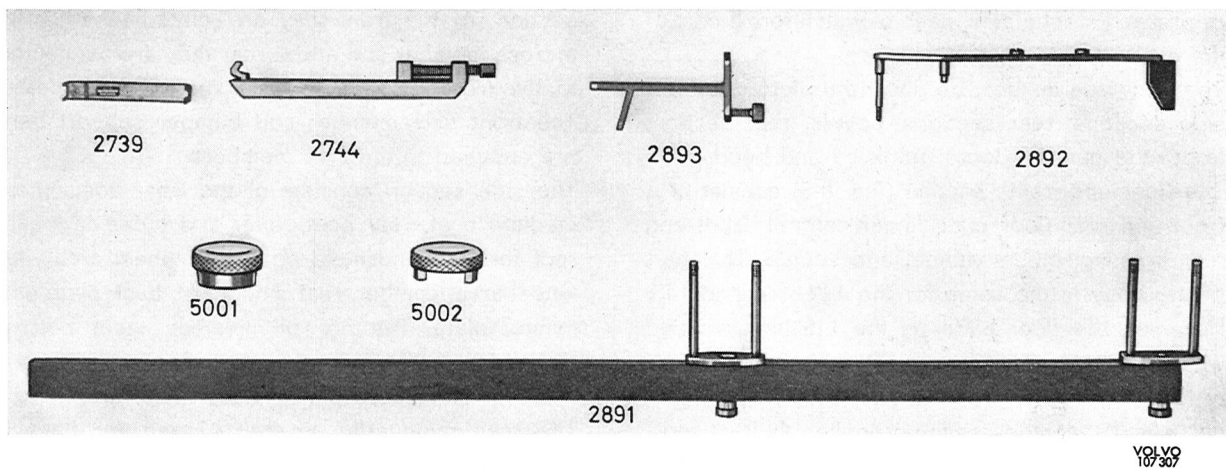

Fig. 8-1. Tools for body

- 999 (SVO)
- 2739 Clamp for spring support, trunk lid
- 2744 Press tool for spring support, trunk lid
- 2891 Straight edge for measuring height of side member

- 2892 Arm for measuring height of side member
- 2893 Holder for fixing straight edge
- 5001 Guide for fixture for replacing side members, left
- 5002 Guide for fixture for replacing side members, right

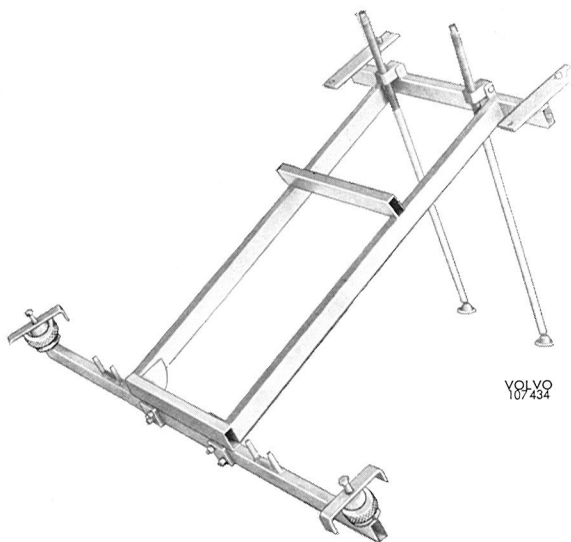

Fig. 8-2.

- 999 (SVO)
- 2777 Fixture for replacing side members

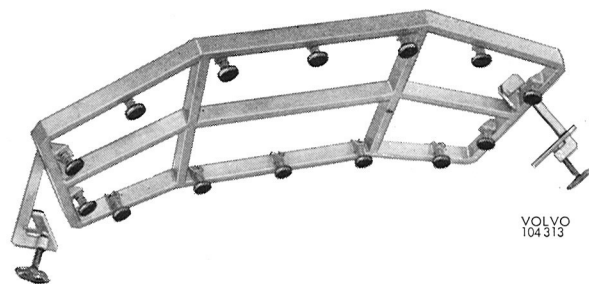

Fig. 8-3.

- 999 (SVO)
- 2899 Fixture for windshield installation

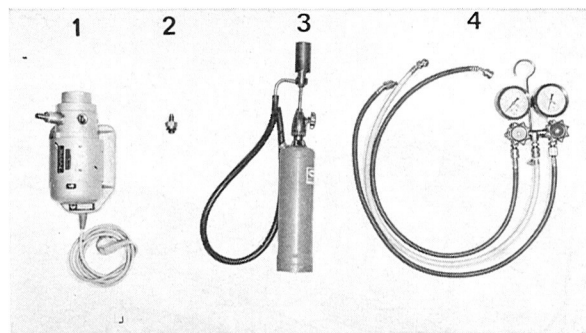

Fig. 8-4. Equipment for leakage testing and filling

1. Vacuum pump Minni, single-phase
2. Nipple for vacuum pump SK-1229
3. Leak detector LP 631 with LPG bottle
4. Pressure gauge kit with hoses

## GROUP 81

# BODY FRAME

## GENERAL INFORMATION

The car has an integral body so that there is no chassis frame. The body is composed of a number of pressed steel plates, each of which forms part of the supporting construction.

The body can suitably be divided up into the floor, side sections, rear sections, scuttle, roof section, front mud guards, doors, trunk lid and hood.

The floor and frame section (Fig. 8-5) consist of a front and rear floor plate, inner cantrail, front and rear cross members, tunnel and scuttle. This part of the body is the same for the 142, 144 and 145. However, the floor plate on the 145 is reinforced with a frame extreme rear. The floor plates are welded together at the rear seat support. The tunnel, which accommodates the propeller shaft, is spot-welded to the floor plates. The rear floor plate has a longitudinal reinforcing member on each side at the bottom and between these a number of cross members. One of the cross members is provided with an attachment for the rear axle track bar. The scuttle (Figs. 8-6 and 8-7) consists of the firewall, wheel arches, front upper cross member and lower cross member. The firewall forms the front trans-

verse wall of the body and has welded end pieces. Two front side members project from the front floor section. At the front they are jointed together by a cross member and at the rear they are connected to the front cross member under the front seats. The front axle member and bumper support bars are attached to the side members.

The side section consists of the front post, intermediate post, rear post, inner and outer cantrails, roof former, windshield post, rear wheel arch with wheel arch member, rear mudguard, back plate and joining plate. The firewall member, inner bottom rail and end plates on the rear wheel housing are made of galvanized plate.

The rear mudguards on the 142 and 145 have a reinforcing profile which is bonded to the inside. The roof section (see Figs. 8-6 and 8-7) consist of a number of pressed steel plates. These roof plates form the upper part of the scuttle, the windshield opening, the roof itself, the opening for the rear window and the front limit of the trunk lid.

The body is noise and heat-insulated. The insulation consists of self-adhesive foam rubber material.

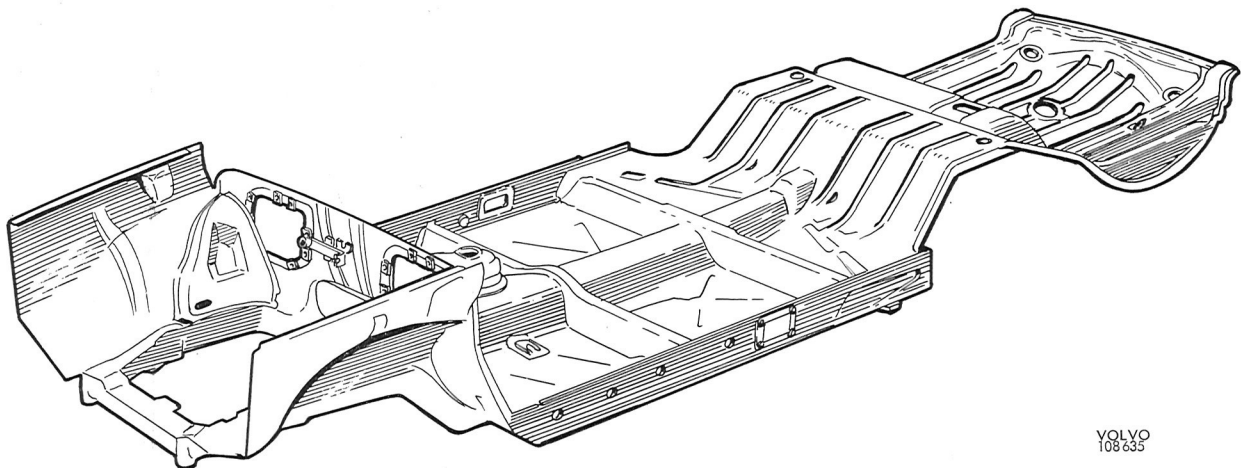
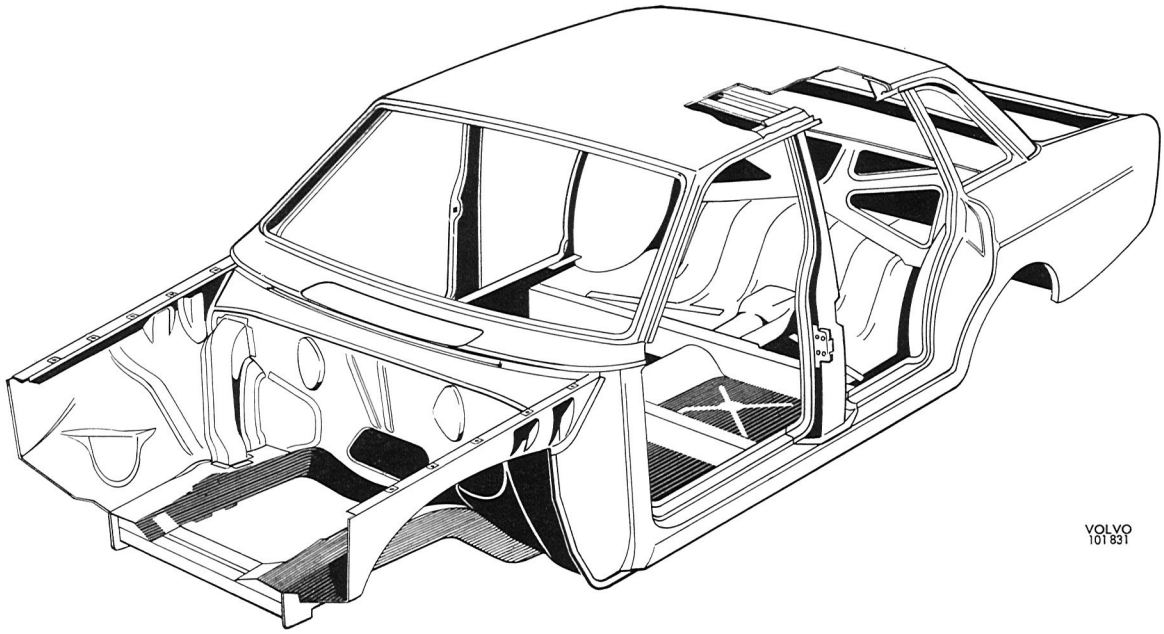

Fig. 8-5. Floor section

VOLVO  
108635



VOLVO  
101831

Fig. 8-6. Body, 144

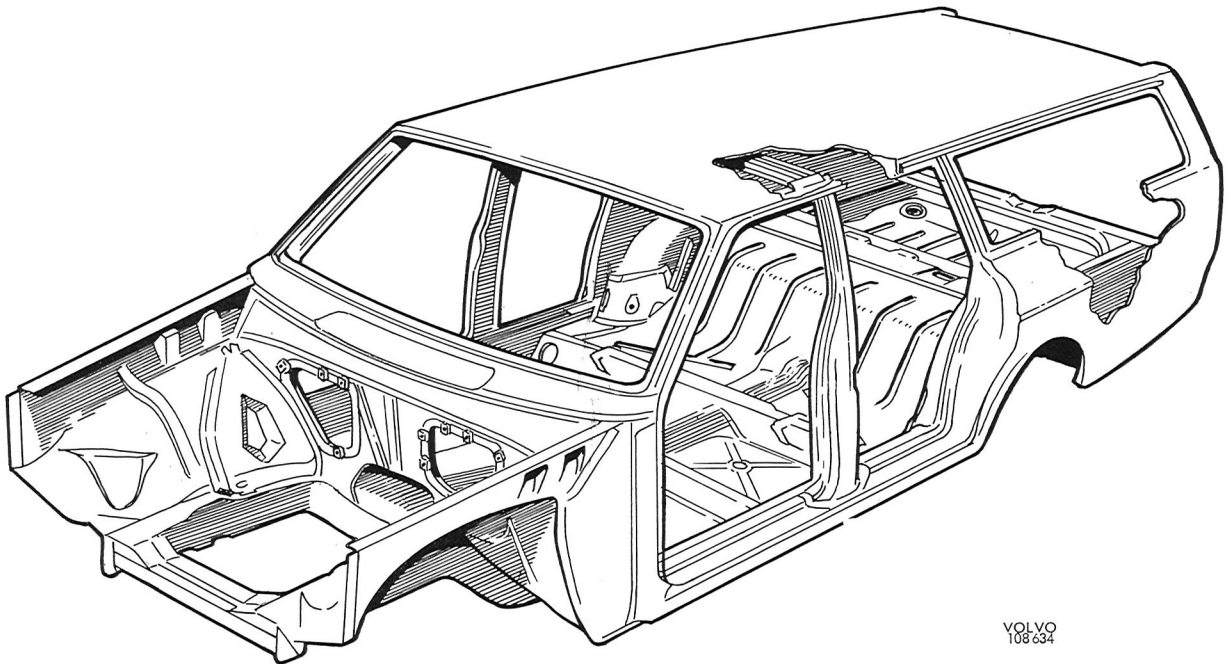

VOLVO  
108634

Fig. 8-7. Body, 145

# SERVICE PROCEDURES

## Mounting of tool for front side members

In order to ensure accuracy when joining or straightening front side members, a fixture with its tools is available. Before the fixture can be placed in position, the front end, engine and transmission must be removed.

1. Set up the fixture 2777. The rear guide pins with the guides 5001 and 5002 (7, Fig. 8-8) fit in the holes in the floor plating and are held in position by clasps (8).
2. Screw the holder 2893 (5) to the side member, with a bolt in the second attaching hole from the front for the rear engine mounting.
3. Place the straight edge 2891 (2) immediately under the side member so that the front support studs (3) are immediately behind the member for the jack attachment. Rotate the support studs so that they almost support against the sides

of the member and lock them in this position. Make sure that the contact points of the support pins are free from underbody sealing and that they do not come against the member flange profile. Tighten the bolt (4) in the holder 2893 so that the straight edge remains steady. Do not tighten so hard as to bend the straight edge.

4. The measuring arm 2892 (1) is secured to the side member by studs in both the front attaching holes for the steering gear and idler arm. On the right member place the measuring arm on the outside, and on the left one on the inside.

The distance between the measuring arm and the straight edge should be the same for both side members within 2 mm (.08"). The distance may not be greater than 6 mm (.24").

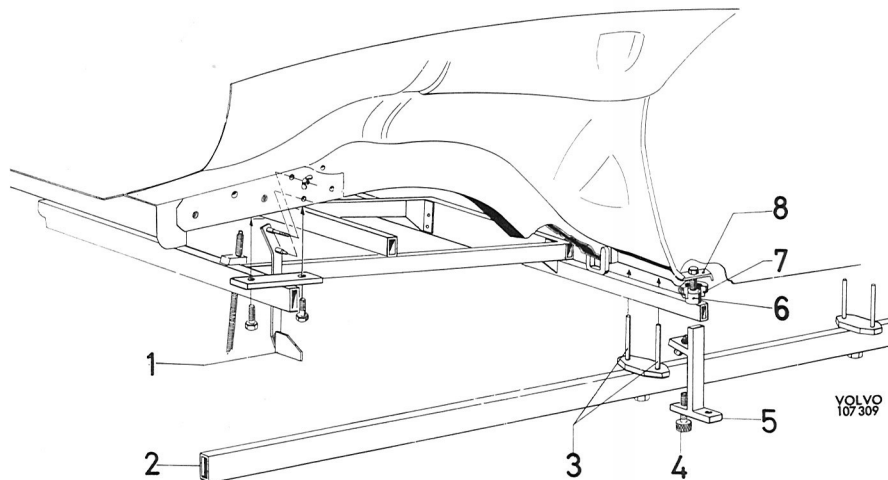

Fig. 8-8. Tools for replacing side members

- |                        |                   |
|------------------------|-------------------|
| 1. Measuring arm       | 5. Retainer       |
| 2. Straight edge       | 6. Rear guide pin |
| 3. Front support studs | 7. Guide          |
| 4. Bolt                | 8. Clasp          |

# HOOD AND MUD GUARDS

## GENERAL INFORMATION

The hood consists of an outer and an inner plate which are bonded together with adhesive. The hood is hinged at the back on two hinges. In the closed position the hood is secured by a lock on the front section. The lever for the hood lock is operated by a control placed underneath the dashboard inside the car.

The front mud guards, front section and hood make up the front end. The front mud guards are pressed in one piece and bolted to the wheel arch plates. The front section forms the front part of the front end as well as the air duct to the radiator. The lower part of the front end is made of galvanized steel sheets.

## SERVICE PROCEDURES

### FRONT MUD GUARDS

The front mud guard is taken off by removing the following bolts: The bolt between the mud guard and stay at the lower side member, the four bolts between the rear edge of the mud guard and body (these bolts are accessible when the front door is opened), the bolts between the mud guard and front plate and the bolts in the upper side member. Installation is done in the reverse order.

### FRONT SECTION

The front section is attached to the front mud guards, wheel arch plates and the lower cross member.

When removing, first disconnect and take out the battery, then unscrew the bolts between the battery shelf and front section. Next remove the radiator grille, the headlights (see Section 3), the bolts between the front section and mud guard, the bolts in the lower cross member and the bolts in the wheel arch plates.

### HOOD AND HOOD LOCK

The hood is attached to each hing by bolts. It is removed by unscrewing the bolts between the hinges and hood. The hinges are attached to the body with three bolts, each accessible for removal under the mud guard. All the holes in the hinges are oval in order to permit hood adjustment.

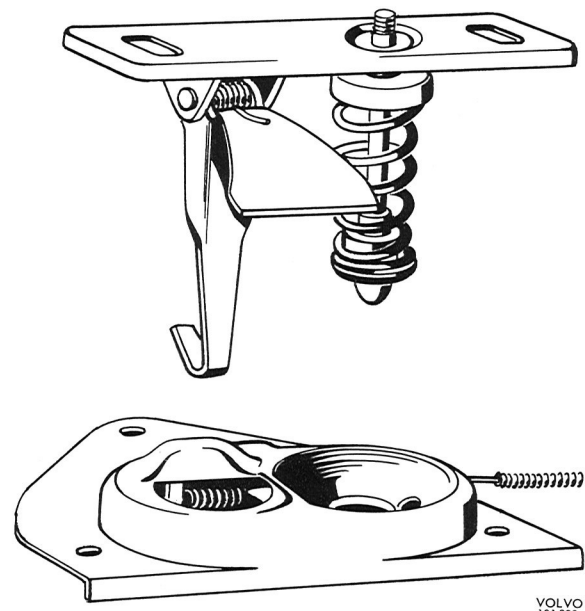

Fig. 8-9. Hood lock

VOLVO  
101 833

The locking pin of the hood lock (Fig. 8-9) is adjustable longitudinally due to the holes in the attaching plate being oval. The length of the locking pin is adjustable nuts. The locking pin and spring are lubricated with grease.

The hood contact at the corners when closed can be adjusted by screwing out or in the rubber stops there.

## GROUP 83

# DOORS AND TRUNK

## GENERAL INFORMATION

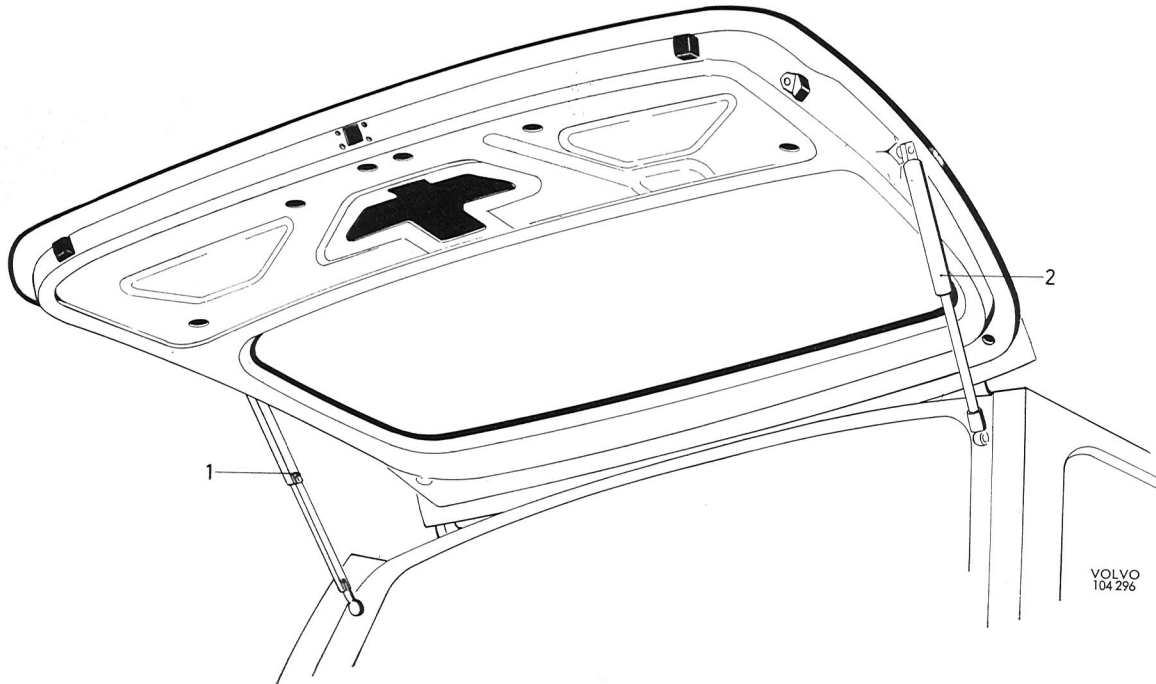

Fig. 8-10. Tail gate

1. Mechanical catch      2. Gas spring

The doors are built up of an inner and an outer plate which are flanged and spot-welded together. Hinges are fitted to the inner plate. The doors are adjustable longitudinally, vertically and laterally. The door locks are fitted to the doors with screws. The door handle on the outside actuates a lever which lifts the lock pin of the door lock by a pull rod. The door opener inside the car is attached to the inner door plate with screws. The handle transmits the movement to a lever which lifts the locking pin by link rods in the lock. On the front doors the lock mechanism is fitted in a cylinder under the door handle.

The rear doors are equipped with child-safety locks. The locks incorporate a latch which prevents the door from being opened from the inside when the latch is down.

The door arches are steel and welded to the door. The window winders consist of lifting arms with toothed segments. The window runs in sliding grooves in the inner door plate and is set to the desired position by a lifting arm from the toothed segment with the assistance of a helper arm.

The trunk lid on the 142, 144 models is built up of

an outer and inner plate bonded together with adhesive. The catch for the locking device is attached to rear edge of the trunk lid. The hinges are on the front edge of the lid and are bolted to the body. The trunk lid is counter-balanced by a spring support and can be set in any desired position when opening. The locking device is installed on the body below the lid and is of the turning type.

The tail gate on the 145 model is also built up of an outer and inner plate which are spot-welded together. The tail gate lock is located at the foot of the tail gate, and the hinges are mounted near the top. The hinges are screwed to the car roof. The tail gate is lifted up by a gas spring at the right-hand side. A mechanical catch locks it in the open position desired. See Fig. 8-10.

The 142 and 144 models are also available with a sun roof. The roof is operated by a crank handle, which is folded in the recess in the roof upholstery between the sun visors when not in use. Any water that penetrates the joint between the body roof and sun is collected in the inner roof plate and conducted away through four hoses installed through the corner posts of the roof.

# SERVICE PROCEDURES

## DOORS

### Removing and installing door stops

Replace door stop=Volvo Standard Times Op. No. 83106

Remove the door panel in accordance with the instructions under "Removing inner handles and upholstery". Then remove the bolt between the door stop and post, and remove the rubber sealing (see Fig. 8-11). After this, remove the three bolts secur-

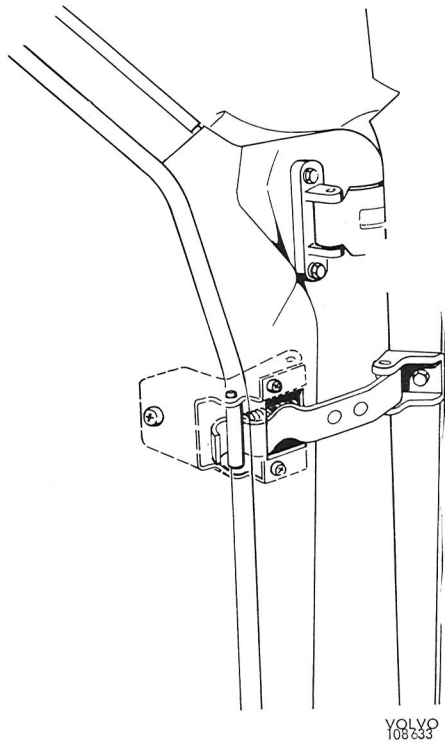

Fig. 8-11. Door stop

ing the door stop to the door. The door stop can now be taken out through the upper opening in the inner plate of the door.

Installation is in the reverse order

### Removing inner handles and upholstery

Replace door window crank=Volvo Standard Times Op. No. 83402

1. Remove the arm rest in the front door by taking out the two plastic plugs with a narrow screwdriver and removing the attaching screws located on the inside. Then turn the plastic ring at the front edge of the arm rest several turns to the left, push the arm rest forwards and the hook at the front edge disengages leaving the arm rest to be removed.

Remove the two retaining screws for the rear door arm rest.

2. Put a finger on the inside of the crank and press the latches holding the cover. Pry loose the cover, using a screwdriver. Remove the Phillips screw and the crank.

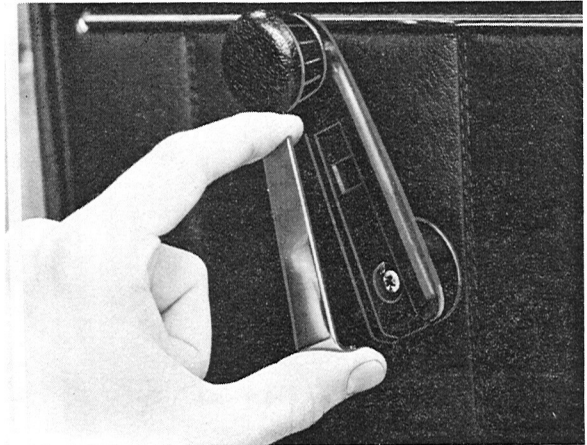

VOLVO  
108184

Fig. 8-12. Door window crank

3. Remove the screws at the top edge of the upholstery and then remove the door upholstery by inserting a screwdriver or similar under the upholstery edge and carefully prying outwards so that the upholstery comes away.

### Removing and installing front doors

Remove the door stop in accordance with the instructions under "Removing and installing door stops". Remove the bolts between hinges and door. The bolts are accessible when the door is opened. The door can then be removed (Fig. 8-13). In order to remove the hinges, the panel in front of the door has to be removed. When this has been done, the three bolts are removed and now the hinges can be removed.

The door and hinges are installed in the reverse order. For installing the door stop, see under "Removing and installing door stops".

Since the holes in the hinges and in the attachment between the door and hinges are oval, the door can be adjusted laterally. The door can be adjusted vertically and sideways in the attachment between the hinges and door post. This is possible since the holes in the door post are larger than the diameter of the bolts.

### Removing and installing rear doors

See the corresponding section above.

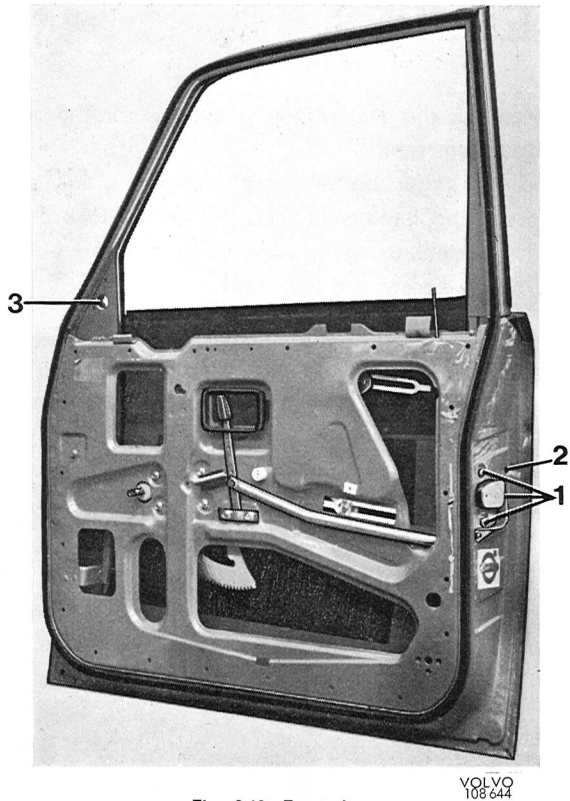

Fig. 8-13. Front door

1. Door lock screws
2. Hole for the lock cylinder attaching screw
3. Hole for rear view mirror installation

### Removing front door lock

Replace door lock=Volvo Standard Times Op. No. 83406

1. Follow operations 1—3 under "Removing inner handles and upholstery".
2. Remove the lock cylinder by its attaching screw (2, Fig. 8-13) which is fitted in the rear edge of the door.
3. Remove the locking for the pull rod locking knob and take out the pull rod.
4. Remove the locking for the inner door opener push rod.
5. Remove the locking for the outer handle pull rod.
6. Remove the three retaining screws for the door lock and the lock.

The retaining screws (1, Fig. 8-13) are located on the rear edge of the door.

### Removing outer handle, front doors

Replace outer door handle=Volvo Standard Times Op. No. 83404

1. Crank up the window to closed position.
2. Remove inner door handle and upholstery according to previous instructions.
3. Crank down the window until the two retaining screws (7, Fig. 8-14) are accessible. Remove the screws.
4. Unhook the return spring (8, Fig. 8-14) and lift out the handle and cover as a unit.

### Installing outer handle, front doors

1. Place the handle in position in the door and move the pull rod (9, Fig. 8-14) in the lifting arm for the handle.
2. Screw in both the attaching screws (7, Fig. 8-14).
3. Check to make sure the lock functions properly. If necessary adjust the length on the pull rod (9, Fig. 8-14).
4. Install the return spring (8, Fig. 8-14).
5. Put back the door upholstery and re-install the inner handle.

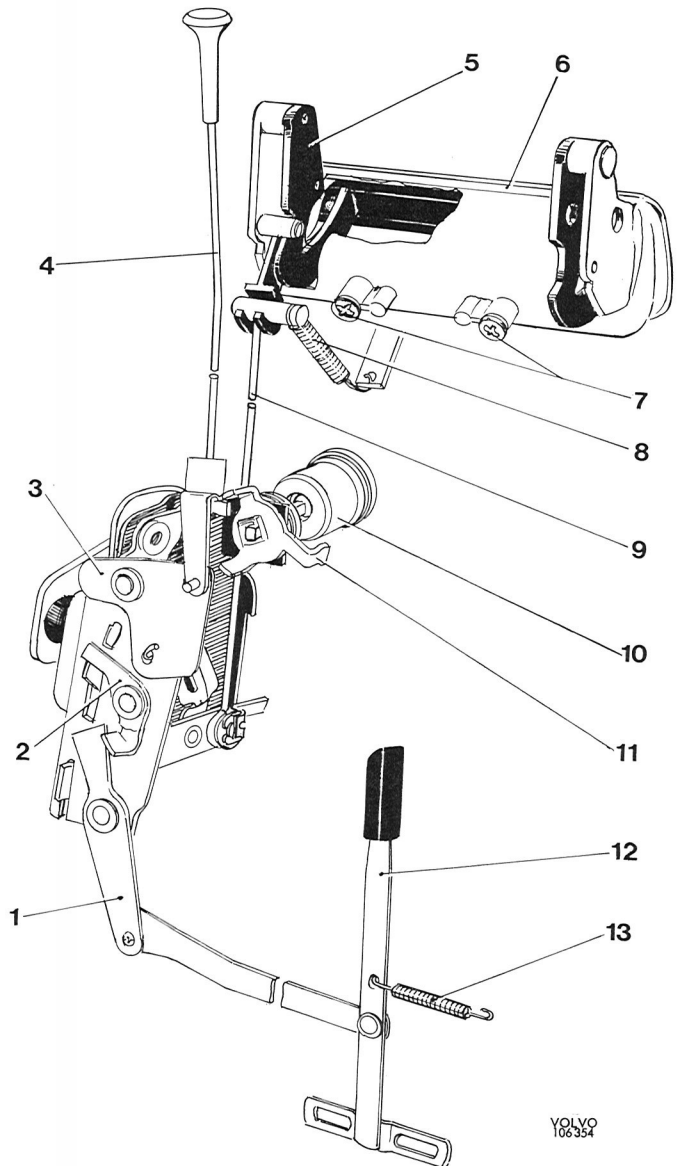
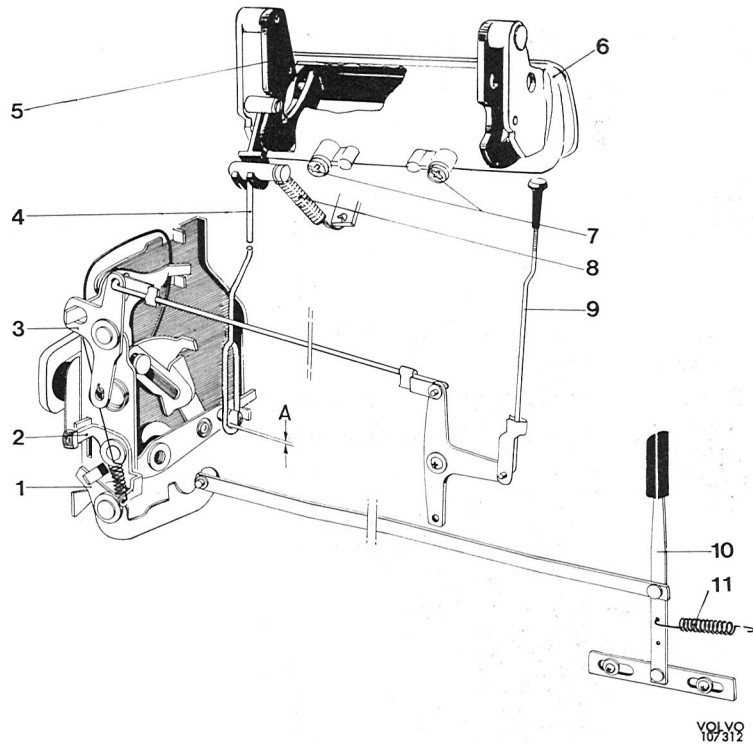

Fig. 8-14. Lock, front doors

1. Lever
2. Lever
3. Lever
4. Pull rod for lock button
5. Outer handle
6. Cover for outer handle
7. Screws for outer handle
8. Return spring for outer handle
9. Pull rod for outer handle
10. Lock cylinder
11. Lock device
12. Inner door opener
13. Return spring for inner door opener

Fig. 8-15. Lock, rear doors

1. Lever for remote control
2. Lever for child safety door lock
3. Lever
4. Pull rod for outer handle
5. Outer handle
6. Cover for outer handle
7. Screws for outer handle cover
8. Return spring for outer handle
9. Pull rod for lock button
10. Inner door opener
11. Return spring for inner door opener



## Removing rear door lock

Replace door lock=Volvo Standard Times Op. No. 83406

1. Carry out operations 1—3 under "Removing inner handles and upholstery".
2. Remove the locking for the pull rod locking knob.
3. Remove the locking for the inner door opener push rod.
4. Remove the locking for the outer handle pull rod.
5. Remove the retaining screws for the door lock and remove the lock from the door. The attaching screws for the lock are placed on the rear edge of the door.

4. Install the return spring (8, Fig. 8-15) and check that the lock is functioning properly.
5. Install door upholstery inner handle.

## Removing outer handle, rear doors

1. Wind up the window to the closed position.
2. Remove the inner handle and upholstery according to previous instructions.
3. Unhook the return spring (8, Fig. 8-15).
4. Unscrew the screws (7, Fig. 8-15) and lift out the handle and cover as one unit.

## Installing outer handle, rear doors

1. Place the handle in position in the door and move the pull rod (4, Fig. 8-15) in the lifting arm for the handle.
2. Screw in the attaching screws (7, Fig. 8-15).
3. Check to make sure that there is a clearance (A, Fig. 8-15) of  $1 \pm 1$  mm ( $1/32 \pm 1/32$ ") between the pull rod eyelet and pin in the lock lever.

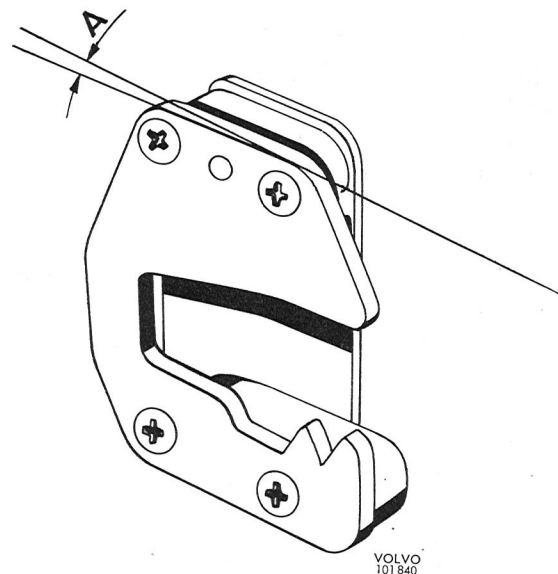

Fig. 8-16. Striker plate

A. Front door 1.5° B. Rear door 2.5°

## Striker plates

The striker plate is made of steel and is installed with a floating nut plate. The striker plate is adjustable since the holes in the body are larger than the diameter of the attaching screws.

The vertical position of the striker plate is controlled by closing the door, with the outside handle pulled out, when the door latch should slide correctly into the latch plate. The striker plate should have an inward inclination of 1.5° for the front doors and 2.5° for the rear doors, see Fig. 8-16.

## Removing front door window

1. Crank down the window to its lowest position.
2. Bend out the cover, remove the screw and the crank.
3. Remove the arm rest and the door panel. Remove the large sheet of water protection.
4. Remove the lock springs and the washers on the inside of the regulator arms. Bend the regulator arms outwards and separate them from the window channel.
5. Remove the window by lifting and turning towards the vehicle as shown in Fig. 8-17.



VOLVO  
108 185

Fig. 8-17. Door window removal

## DOOR WINDOW INSTALLATION

1. Install the window in the window channel according to Fig. 8-18 and 8-19.

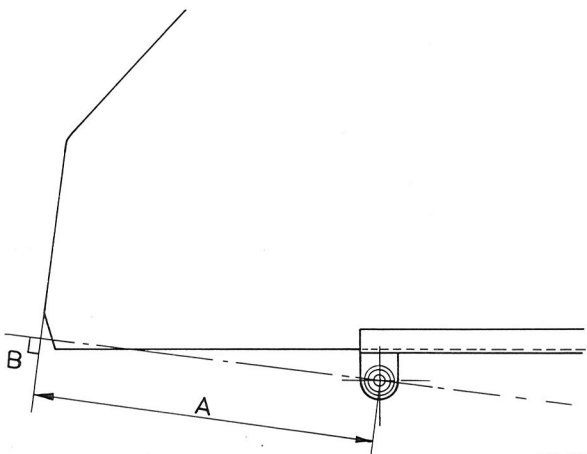

VOLVO  
108 224

Fig. 8-18. Window dimensions, 142 and front door 144, 145

$$A=263\pm 2 \text{ mm}=10.275''-10.443''$$

$$B=90^{\circ}\pm 1^{\circ}$$

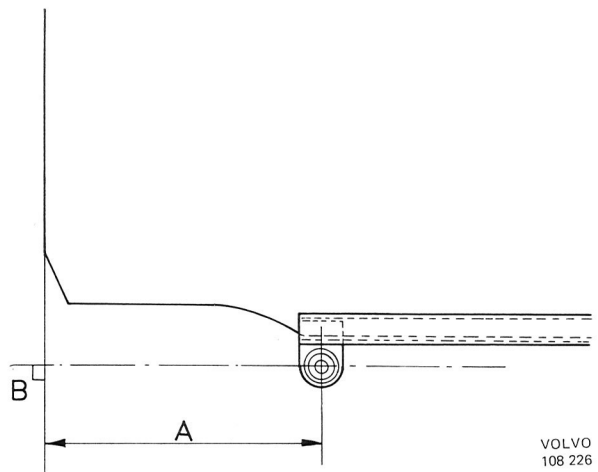

VOLVO  
108 226

Fig. 8-19. Window dimensions, rear door 144, 145

$$A=169\pm 2 \text{ mm}=6.654''-6.732''$$

$$B=80^{\circ}\pm 1^{\circ}$$

2. Lower the window with the acute angled corner first and turn it at the same time as shown in Fig. 8-20.



VOLVO  
108 186

Fig. 8-20. Window installation

3. Check that the window is aligned in the window runs.
4. Fit the regulator arms in the window channel and install the washers and the lock springs.
5. Install the water protection springs.
6. Install the door panel, the arm rest and the window crank.

## Removal and installation of rear door window

See the corresponding section above.

## REMOVAL OF DOOR WINDOW CRANK MECHANISM

Replace front door window regulator=Volvo Standard Times Op. No. 83504

1. Crank down the window to its bottom position.
2. Remove the door panel and the water protection sheet.
3. Remove the lock springs and the washers on the inside of the regulator arms. Bend the arms outwards and remove them from the window channel.
4. Remove the clip (1, Fig. 8-21) at one of the regulator arm's retaining points in the door.
5. Remove the door window crank mechanism retaining screws (2, Fig. 8-21).

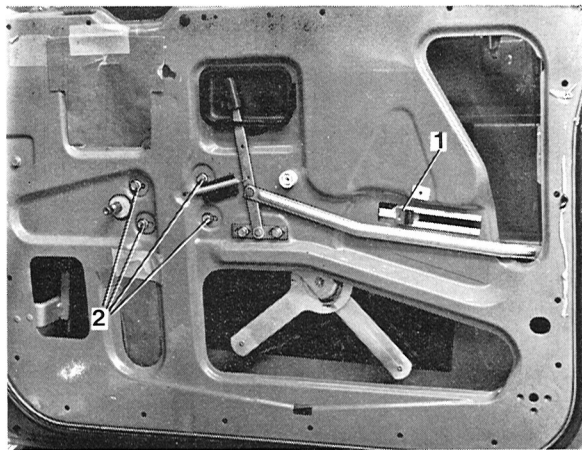

Fig. 8-21. Front door, interior

1. Lock
2. Window mechanism retaining screws

6. Remove the crank mechanism as shown in Fig. 8-22.



Fig. 8-22. Window mechanism removal

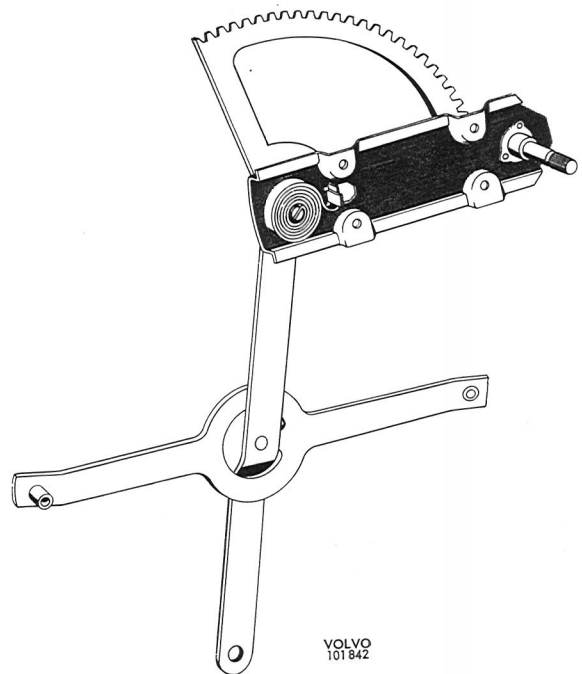

Fig. 8-23. Window mechanism

## INSTALLATION OF WINDOW CRANK MECHANISM

1. Install the crank mechanism with the screws (2, Fig. 8-21). Do not tighten the screws.
2. Install the regulator arms first in the door and then in the window channel with the washers and the lock springs.
3. Crank the window to its upper position and tighten the crank mechanism screws.
4. Install the water protection sheet.
5. Install the door panel, the arm rest and the window crank.

## Removal and installation of rear door window mechanism

Replace rear door window regulator=Volvo Standard Times Op. No. 83502

Proceed in the same way as described above.

## TRUNK LID, 142, 144

The trunk lid is mounted on two hinges, which are attached by two bolts to the inner plate of the lid and with three bolts to the pillar under the rear window.

The trunk lid is counterbalanced by a spring support.

The trunk lid is removed by removing the two bolts on each hinge and lifting it off.

When replacing, the lid is first opened fully. It is then lowered slightly and clamp 2739 applied and the lid opened fully again, after which the spring support can be removed. When installing a new

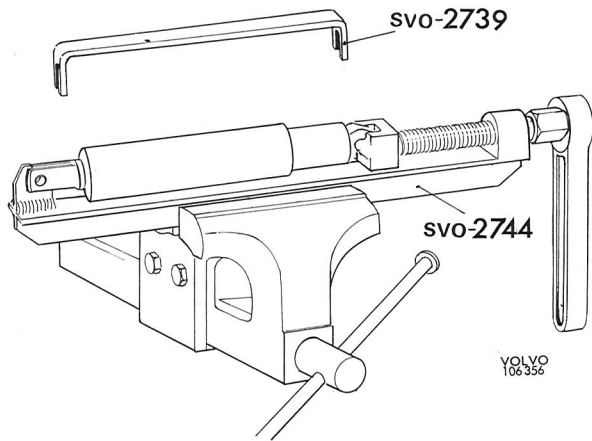

Fig. 8-24. Tools for spring support

spring support, press tool 2744 is used as shown in Fig. 8-24 in order to install clamp 2739. Install in the reverse order.

When removing the hinges, first remove the spring support as described above. The lid is then removed from the hinges and after this the hinges from the body.

The holes in the part of the hinges attached to the trunk lid are oval in order to permit longitudinal adjustment. For vertical adjustment the holes in the part of the hinges attached to the body are oval.

The lock (Fig. 8-25) is installed in the rear section and is released by turning the lockable knob. The lock catch on the lower edge of the lid is adjustable in order to permit variation of the closing tension of the lid.

The lock knob is removed by taking out the horseshoe clamp with pliers inside the trunk. The lock knob can then be pulled out backwards.

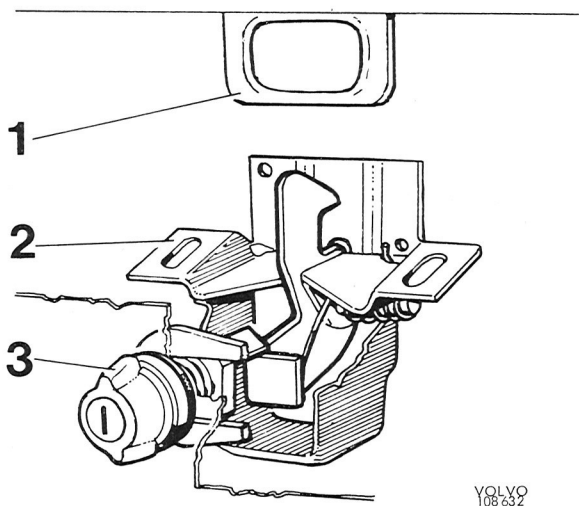

Fig. 8-25. Lock for trunk lid

1. Lock catch, fitted in lid
2. Lock mechanism, fitted in rear section
3. Lock knob, fitted in rear section

To remove the lock, remove the lock knob and then the two bolts under the upper edge of the rear section.

The lock is adjustable longitudinally since the bolt holes are oval.

## TAIL GATE, 145

The tail gate on the 145 model is suspended by two hinges screwed to the roof. To remove the tail gate, first remove the upholstery panel on the inside. Then remove the left-hand license plate lamp and disconnect wire. Disconnect also the other outgoing wires from their connections inside the tail gate. The gas spring is then taken out at its attachment in the tail gate. Finally, loosen the screws for the hinge attachments to the tail gate and lift off the tail gate.

The following is the procedure for installing the tail gate: Lift up the tail gate, and insert the electrical wires. Position the tail gate and screw on the hinges. If the gas spring was removed, install it and adjust its play where attached to the body. Install the license plate lamp, electrical wire and the upholstery panel.

The tail gate lock, Fig. 8-26 must be removed from the inside, so that the panel has first to be taken down. Inside the tail gate, the link rod to the lock plunger is removed and also the screws for the lock. The lock can then be moved to the left, from where it is taken out of the tail gate. The lock cylinder is removed by loosening the lock screw inside the tail gate.

To remove the hinges for replacement, detach the headlining at the rear edge (see under "Replacing headlining"). Disconnect the electrical wire at the joints under the hinges. Remove the screws securing the hinges to the roof and the tail gate. Remove the hinges.

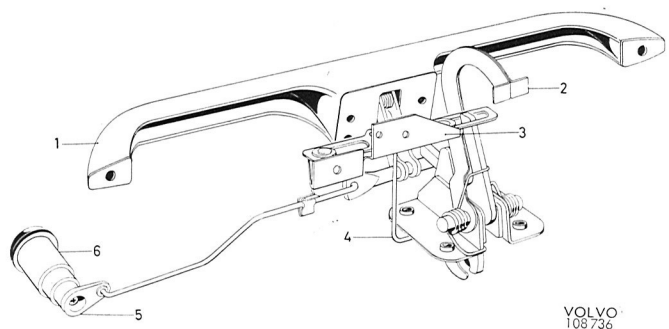

Fig. 8-26. Tail gate lock, 145

1. Outer handle
2. Inside opener
3. Latching device for inner opener
4. Control for latching device
5. Eccentric
6. Lock cylinder

## SUN ROOF

### Removing cable

1. Open the sun roof and release the clips securing the roof upholstery at the front end. Then move the upholstery back to leave an opening.
2. Crank the sun roof forwards and slacken the screws at its four attachments (9 and 11, Fig. 8-27). Bend the leaf springs (10) to the one side and remove the reinforcing plates (13) at the rear attachments. Lift off the sun roof.
3. Remove the wind deflector (2).
4. Remove the intermediate pieces (8), covering strip (3) and holders above the drive. Release the front guide rails (6) and pull out the cables (5).

3. Install the wind deflector.
4. Screw on the roof securely and put back the leaf springs.
5. Crank the sun roof forwards until it is completely closed and check that it is level with the roof. To adjust vertically, use the front adjustment (7, Fig. 8-27) and the lifts at the rear adjustment (12). Also check that both the lifts stand straight up when the roof is closed.
6. The crank and housing (4). Turn the crank to the stop position on the removed gear housing.
7. Install the housing and crank. The crank should now point straight forwards in the vehicle when the sun roof is completely closed.
8. Put back the upholstery and test the function of the sun roof.

### Installing cables

1. Install the cables so that the attachments for the sun roof come opposite each other, and at the rear end of the roof opening. Screw on securely the front guide rails.
2. Install the intermediate pieces, holders and covering plate.

### Replacing sealing strip

The sun roof must be removed in order to replace the insulating strip and sealing strip there. See points 1 and 2 under "Removing cable". When replacing the insulating strip round the roof opening of the sun roof, all that is required is to crank the roof back to its rearmost position.

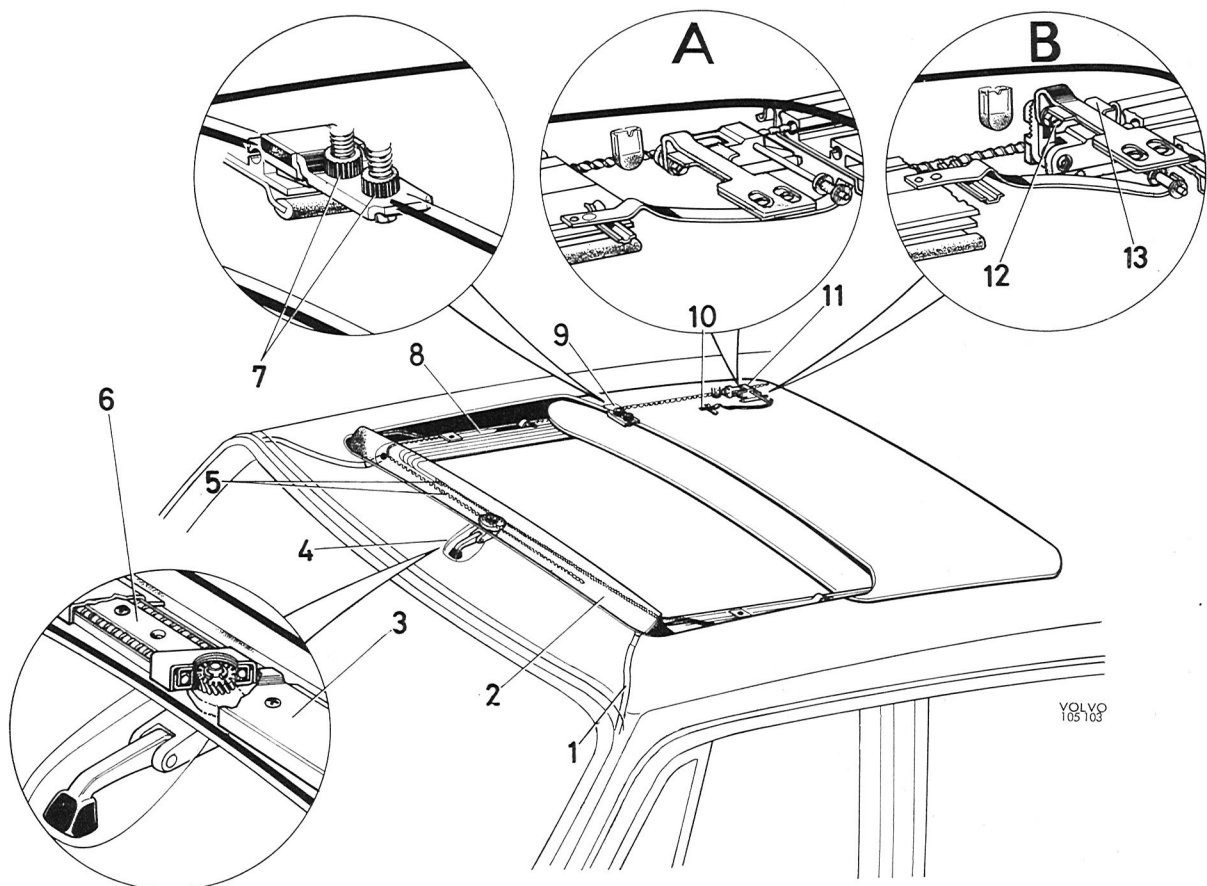

Fig. 8-27. Sun roof

- A. Rear attachment when roof is open  
B. Rear attachment when roof is closed

- |                             |                     |                       |                       |
|-----------------------------|---------------------|-----------------------|-----------------------|
| 1. Drain hose               | 5. Cables           | 8. Intermediate piece | 11. Rear attachment   |
| 2. Wind deflector           | 6. Front guide rail | 9. Front attachment   | 12. Rear adjustment   |
| 3. Cover strip              | 7. Front adjustment | 10. Leaf spring       | 13. Reinforcing plate |
| 4. Crank housing with crank |                     |                       |                       |

# SEALING STRIPS, GLASS AND EXTERNAL TRIM MOULDINGS

## SERVICE PROCEDURES

### SEALING STRIPS

The sealing strips are secured by spotwelded fastening rails.

The sealing strip is removed by pulling it outwards, when the ridge of the strip releases from the rail. When attaching the sealing strip, one of the ridges is placed in position in the rail, the other ridge is then pressed down into the rail with a wooden putty knife. This is moved along the rail as shown in Fig. 8-28.

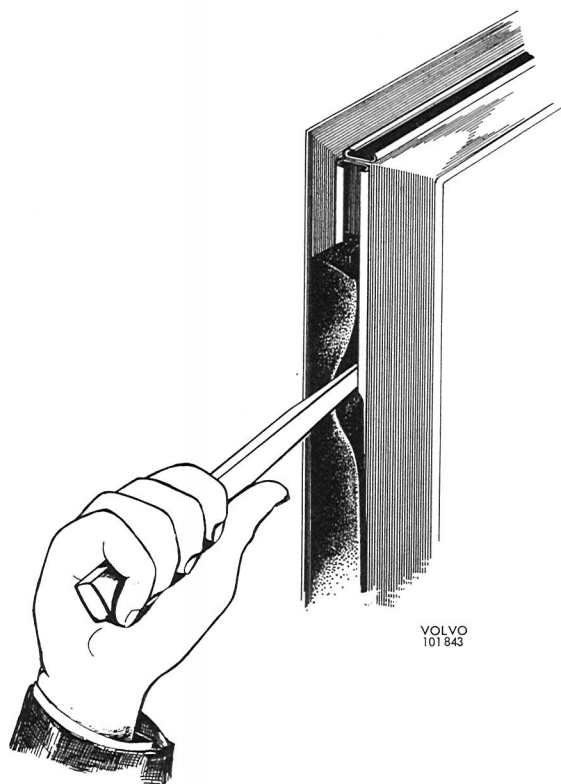

Fig. 8-28. Installing sealing strip

### TRIM MOULDINGS

#### Waist mouldings

The waist mouldings are attached with plastic clips. The mouldings are removed with a wooden putty knife with which they are carefully levered off. The clips can be removed by carefully pulling them off with pliers.

When installing, begin by placing the clips and locking them by pressing in the stud in the middle. The moulding is then pressed onto the clips.

#### Removing windshield moulding

The windshield moulding is fixed by clips pressed into the slits in the windshield opening in the body. The moulding can, for example, be suitably removed with a steel putty knife. Insert the knife between the windshield and moulding opposite a clip, see Fig. 8-29. Then lever the moulding loose.

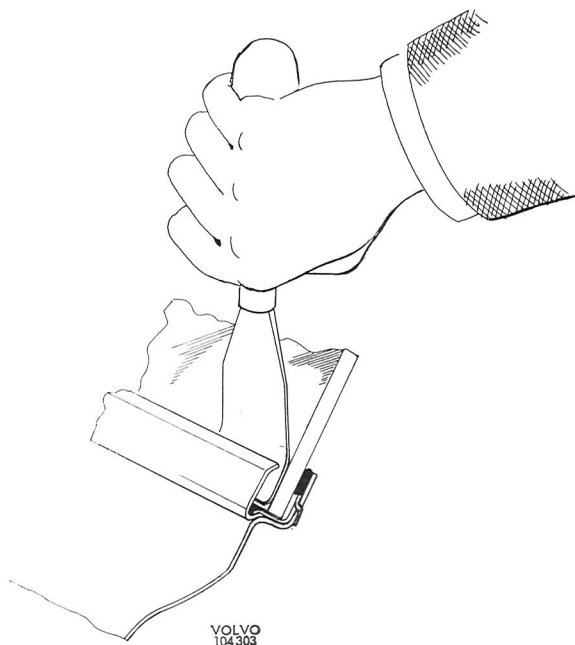

Fig. 8-29. Removing trim moulding

#### Installing

Install the windshield moulding by pressing it in between the body frame and the clips. To ensure that the moulding coincides with the corner joints, install in the following order.

First, install the lower moulding with a corner joint on. Then install a side moulding also with a corner on. Finally, install the remaining moulding together with corners on to the body frame.

## Removing trim moulding for rear window

1. Remove the moulding from the rubber strip by inserting a moistened nylon putty knife and moving it all round between the strips (do not pull off the trim moulding).
2. Push over the joining pieces to one of the halves of the moulding.
3. Remove the trim moulding by levering out the ridge of the rubber strip from the trim moulding with a moistened wooden putty knife and releasing the trim moulding in the middle with another putty knife as shown in Fig. 8-30. Lever off the moulding carefully while releasing the rubber strip with the other putty knife.

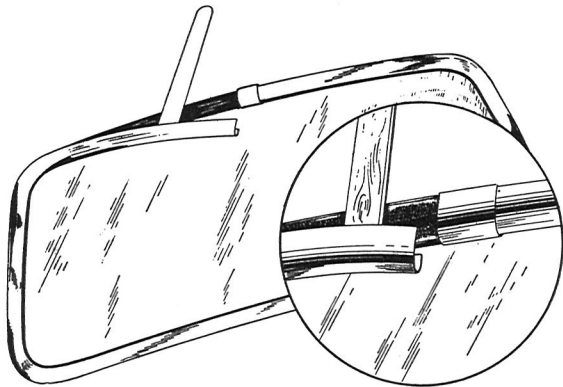

Fig. 8-30. Removing trim moulding

## Installing trim moulding for rear window

Moisten a 4.0 mm (5/32") leather cord in soap solution or paraffin and place it in the groove of the rubber strip for the trim moulding.

Place one half of the trim moulding in position and hold it there while pulling the leather cord out upwards over the moulding so that it is pressed against the rubber strip as shown in Fig. 8-31. Push over the joining pieces and repeat the procedure

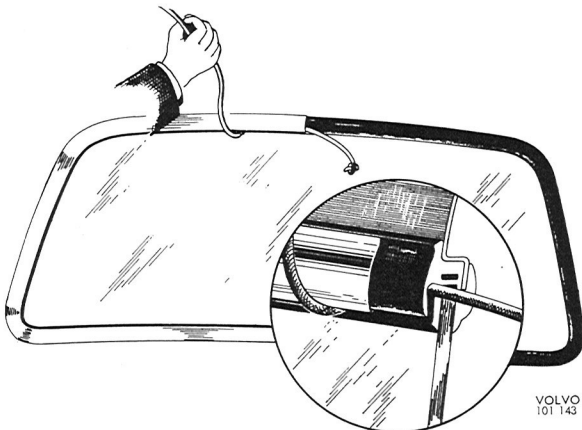

Fig. 8-31. Installing trim moulding

with the other half of the moulding. Adjust the position of the joining pieces over the joints.

## WINDSHIELD

### Removing windshield

Replace windshield=Volvo Standard Times Op. No. 84302

1. Place protective covering over the hood and front seats.
2. Remove the windshield wiper arms.
3. Remove the external trim moulding. See "Removing windshield moulding".
4. Unscrew the inner covering strips and rear view mirror.
5. Cut the windshield loose with a warm soldering iron.

Insert the point of the iron in between the windshield and the body, from the inside of the vehicle, see Fig. 8-32. Then draw the soldering iron all round the windshield. The windshield can now be pressed out by hand. Cut off any remaining strands with a knife.

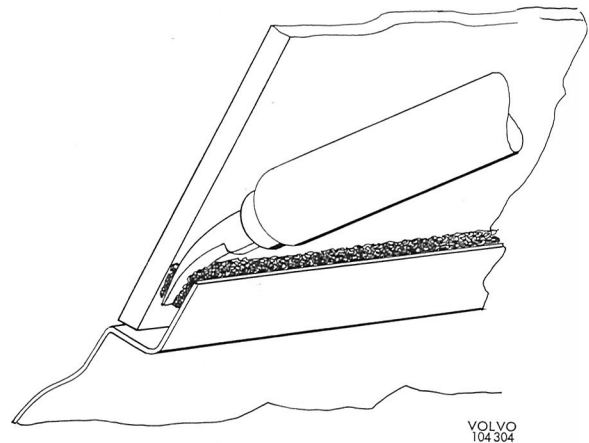

Fig. 8-32. The soldering iron should be on 200 W. The tip may not be so thick that it can come in contact with the glass.

6. Clean the body (also the windshield if it is to be re-installed) of any tape.
7. Remove any defective clips.

### Installing windshield

1. Inject sealing agent into the holes where the new clips are to be installed. Use pump No. 210163.
2. Install new clips.
3. Clean well the surfaces where the tape is to lie on the body and windshield. Use ethyl or methyl acetate for the cleaning. Be careful not to touch the cleaned surfaces.
4. Coat the clips with sealing agent No. 686275 so that the agent forms a smooth bridge between

the clips and body for the butyl tape to seal against.

5. Coat adhesive on the cleaned surfaces on the body and windshield. Coat an edge between 18 and 21 mm (3/4 and 7/8") in width round the windshield, measured from its outer edge. Apply the adhesive twice to ensure total coverage. Any adhesive spill on the body or glass surfaces can be removed with methyl acetate. The adhesive can be applied within 5 minutes after the cleaning.
6. Install both the spacers on the lower edge of the windshield opening. They should lie between the 2nd and 3rd clip from each windshield post.
7. Install the butyl tape on the body not less than 10 minutes and not more than 1 hour after the adhesive has been applied. Roll the tape round the whole of the windshield opening with the protective paper on. The joint should be opposite one of the side posts and the joint's ends should be cut at an angle.

The tape is best cut with a heated knife.

Place the tape edge to edge with the spot weld flange. The tape profile may not be altered by stretching. The protective paper is removed immediately before the windshield is installed. Be careful not to soil or touch the adhesive surface of the tape.

8. Use a glass lifter for installing the windshield. Two men are required to install the windshield. It must be carefully located in the opening before being placed against the tape. Once the windshield has been placed in position, adjusting possibilities are then very small. The windshield must not lie against any clip.
9. Install the fixture 2899 and press the windshield firmly in position. When the outer plane of the windshield lies  $1 \pm 1.5$  mm ( $.04 \pm .06$ ") from the outer edge of the body, then the windshield is in the correct position. Let the fixture remain about 45 seconds.
10. If the butyl tape is squeezed outside the windshield on its inside, cut off the projecting part with a heated knife.

**Note:** If any part of the painted edge on which the butyl tape is installed is seen through the windshield from the outside of the vehicle, apply sealing agent 686275 to these points. This is only required for light-colored vehicles.

11. Install the outer trim moulding, see "Installing windshield moulding".
12. Install the inner cover strips and rear view mirror.
13. Install the windshield wiper arms.

## REAR WINDOW

Replace rear window=Volvo Standard Times Op. No. 84312

### Removing rear window

1. Remove the trim mouldings as described in operations 1—3 under "Removing rear window moulding".
2. Remove the cables for the electrically heated rear window.
3. Release the rubber strip both from the rear window and sheet metal by inserting a wooden putty knife moistened in synthetic washing solution (the putty knife should be moistened now and then during the course of the work) between the rubber strip and rear window and between the rubber strip and sheet metal respectively and moving it all round.
4. Start removing the rubber strip in the upper left-hand corner by levering the rubber strip over the edge of the sheet metal from inside and at the same time carefully pulling out the strip from outside with a pair of wide-nosed grips. Then carefully pull off the strip by hand all round and remove the rear window.

Remove all sealing compound from the sheet metal. If it has dried on, first carefully scrape off the sealing compound and then wash clean with naphtha. Check that the sheet metal edge is not deformed. If the sealing compound has not dried on, clean the rubber strip with naphtha, otherwise replace it.

### Installing rear window

1. Moisten the outer edge of the windshield and install the rubber strip starting at one of the corners. Adjust the strip so that it lies correctly all round.
2. Install a cord (preferably of terylene) of a suitable size in the groove of the rubber strip for the sheet metal edge, beginning at the top center as shown in Fig. 8-33.
3. Place the rear window in position with the rubber strip installed. Wearing working gloves, carefully strike the rear window a few blows with the **palm of the hand** so that it makes good contact all round. Then carefully pull out the cord from inside. This will cause the rubber strip to "creep" over the sheet metal edge as shown in Fig. 8-34. It may sometimes be necessary to adjust the position of the rear window with the palm of the hand. If the cord is difficult to pull

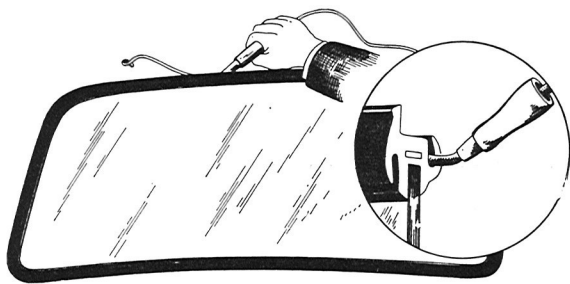

VOLVO  
24817

Fig. 8-33. Placing cord in rubber strip

out, this may damage the strip, in which case the rear window should be struck from inside or outside with the palm of the hand if the rubber strip does not "creep" over the edge of the sheet metal properly.

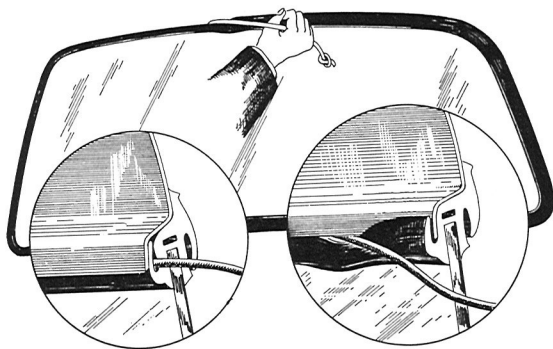

VOLVO  
24822

Fig. 8-34. Installing rear window

4. Check that the rubber strip seals well all round. If necessary adjust the position of the rear window both vertically and laterally **by striking with the palm of the hand.**
5. Seal the joints between the rubber strip and rear window and rubber strip and sheet metal with sealing compound using a gun with a flat nylon nozzle. Make sure that the sealing compound fills the joint well. Scrape off surplus sealing compound and wash the rear window and sheet metal with kerosene. Clean the rear window and sheet metal around it with polish.
6. Install the trim mouldings as previously described.
7. Install the cables for the electrically heated rear (tail gate) window.

## REAR QUARTER WINDOWS

See the corresponding section under "Rear window".

## REAR QUARTER WINDOWS (OPENABLE), 142

In order to be able to remove the glass in the rear quarter windows on the 142 model, open first the quarter window and remove the screws securing the quarter window opener to the body.

Remove the window from the front attachments by first opening it 90° and at the same time pulling to the rear.