

UPHOLSTERY, INTERNAL EQUIPMENT AND HEATING SYSTEM

GENERAL INFORMATION

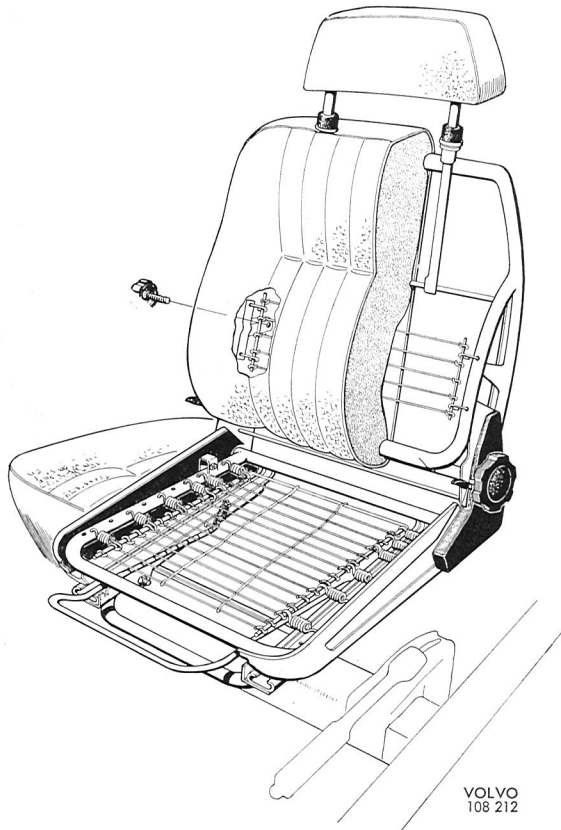

Fig. 8-35. Front seat, De Luxe

FRONT SEATS

The front seats (Fig. 8-35) are built up on a tubular frame. The stuffing consists of foam plastic covered with a durable woven fabric with sides and back in vinyl.

The front seat can be slid forwards and backwards to desired position after the loop handle on the seat front has been lifted. The seat rails on both sides have catches.

The seat can be adjusted vertically at the attachments provided with holes at different heights. The whole seat can be tilted to the desired position by the adjusting device at the front edge on the tube on which the seat is mounted.

The inclination of the seat back is accomplished by a gear system. It is invariably adjustable by turning the hand wheel on the outside of the seat.

The seat is provided with an adjustable lumbar support, the tension can be adjusted by a knurled knob located on the tunnel side of the back rest. The seat cushions are fastened to the seat frame by press-studs.

On the 142 where the back rest can be folded forward, there is an automatic latching device which is released by a lever at the bottom of both sides of the back rest. Inside the lower covers for the folding fittings there are springs which assist in pressing forward the back rest.

Both front seats are equipped with head restraints which can be adjusted vertically.

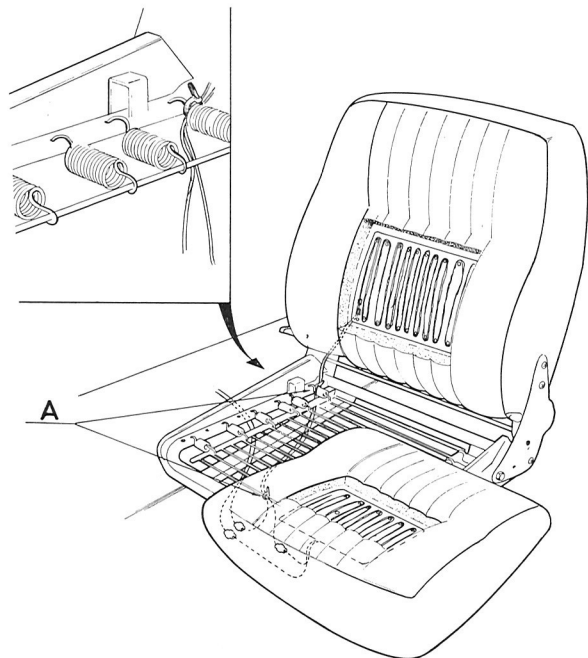

Fig. 8-36. Electrically heated driver's seat

Clamps here

Some models have an electrically heated driver's seat, controlled by a thermostat.

The total current draw is 60 W. The thermostat cuts out at 26°C (78°F) and cuts in at 14°C (57°F).

REAR SEATS

Rear seat cushion and rear seat back are made in polyuretan foam, moulded on a frame of wires which stabilize the foam and retain the upholstery. The 140 GL has a rear seat of the same kind as the front seat, although in this case the seat has a wooden frame.

On the 145 the rear seat cushion can be folded forward and the back rest down to provide more cargo space.

DOOR UPHOLSTERY

The door upholstery consists of wood-fiber sheeting lined with non-woven padding and covered with upholstery material. It is secured to the door by clips. The arm rests are made of moulded plastic and are screwed to the inner plate of the door.

COVERING FOR FIREWALL AND FLOOR

The sides of the bulkhead are lined with millboard. The firewall is covered with self-adhesive insulating material. The floor is covered with textile mats.

HEADLINING

The headlining consists of plastic fabric stretched on roof ribs and secured in retainers fitted on the upper limit of the body sides.

HEATING SYSTEM

The 140-series has two types of heating systems. One is prepared for an air conditioning unit and one is of the conventional type. The former is described in more detail under the heading "Combined heating system" and the latter under "Standard heating system".

Both systems have the same distribution ducts for the heated or cooled air and fresh-air intake.

Air extract vents provide good ventilation. On the 142 and 144 models, these are located under the rear window (Figs. 8-38 and 8-39) and on the 145 under the rear right-hand side window (Fig. 8-40).

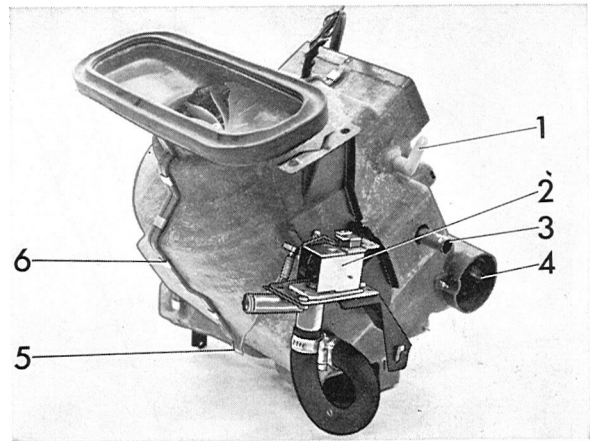

VOLVO
107315

Fig. 8-37. Car heater, standard system

- | | |
|------------------------------|---|
| 1. Shutter shaft for air-mix | 4. Air ducting to defroster and outer air vents in instrument panel |
| 2. Heater control valve | 5. Capillary tube |
| 3. Pressure pipe | 6. Spring clamp |

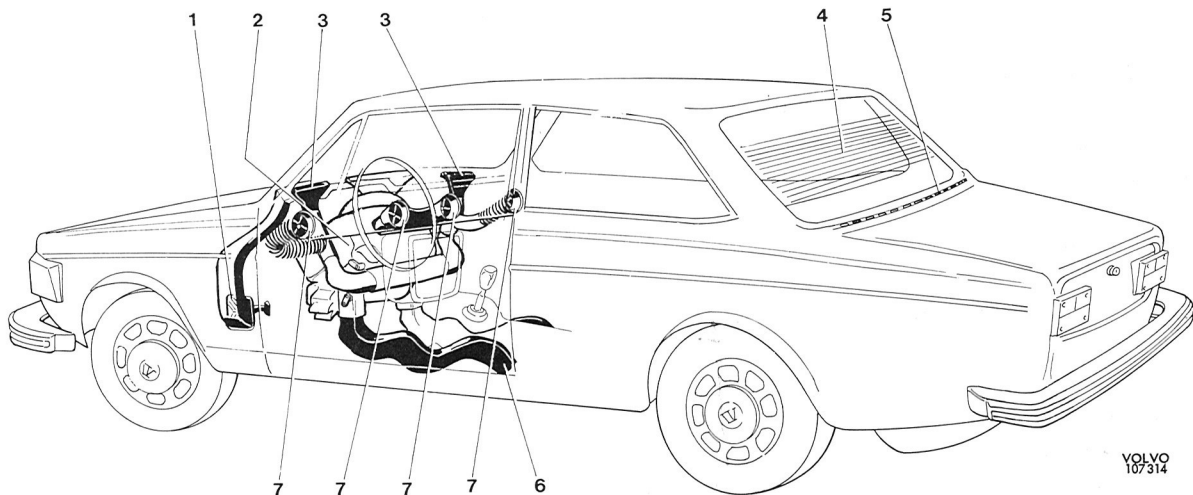

VOLVO
107314

Fig. 8-38. Heating system

- | | |
|------------------------------------|----------------------------------|
| 1. Fresh air intake | 5. Rear vents |
| 2. Car heater | 6. Air ducting to rear seat area |
| 3. Windshield defroster | 7. Air vents in instrument panel |
| 4. Electrically heated rear window | |

(Fresh air can also enter the vehicle through the fresh-air intake in the left cowl side).

The electrically heated rear window also belongs to the heating system. The heating power, which is regulated by a switch on the dashboard, has an output of 150 W.

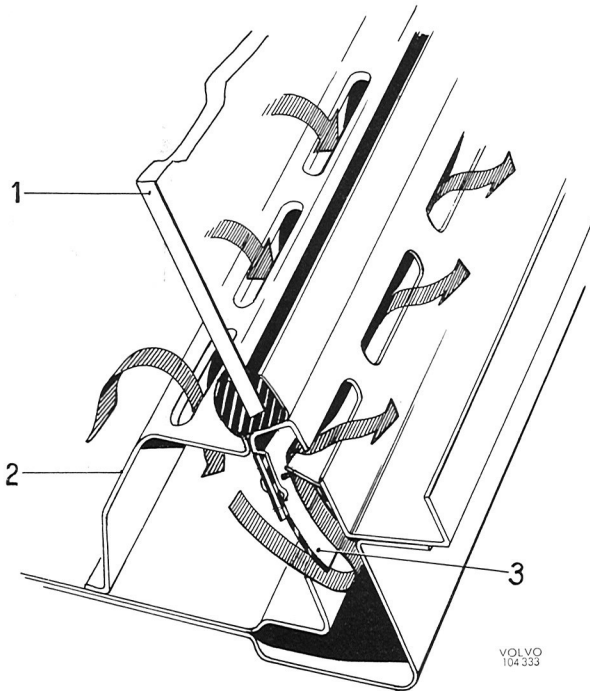

Fig. 8-39. Air extractor vents, 142 and 144

1. Rear window
2. Non-return valve
3. Inner grille

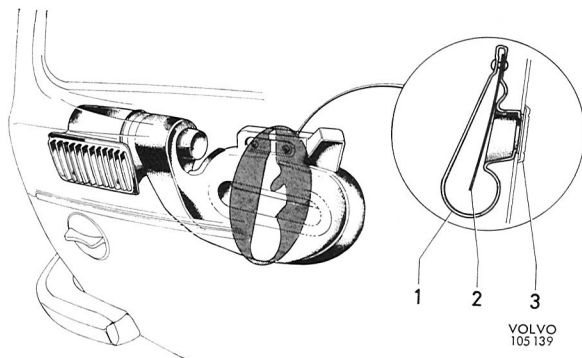

Fig. 8-40. Air extractor vents, 145

1. Air duct
2. Check valve
3. Inner grille

Standard heating system

This is a combined warm-air and fresh-air system. The incoming air is forced, by a blower, through the cellular system of the heater unit and then through the various distribution channels into the car. The fresh air can be heated and directed to the

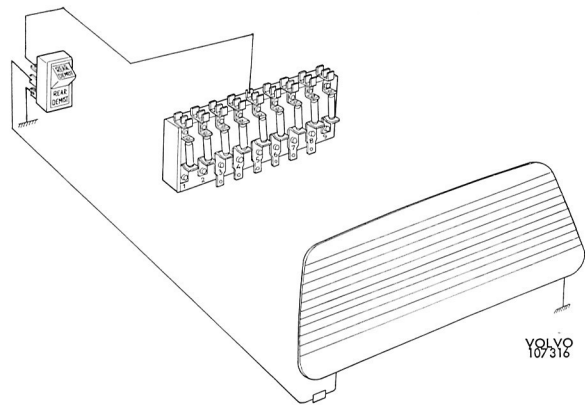

Fig. 8-41. Wiring diagram for electrically heated rear window

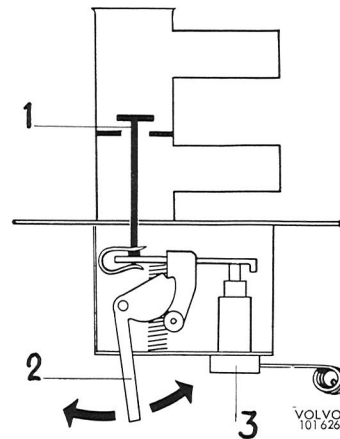

Fig. 8-42. Principle of heat control valve

1. Valve
2. Lever for heating controls
3. Thermostat

required area of the car by various controls. The temperature of the heated air is regulated by a heat control valve (Fig. 8-42). The heat control valve is intended to keep the heated air at a predetermined and constant temperature. This is achieved by the thermostat which is incorporated in the control valve. The temperature control regulates the supply of heated coolant to the cell system. The heater coolant warms up the air which is fed through the heater unit by the blower or the slipstream. If the coolant temperature increases, the thermostat capillary expands thus acting on the valve in the control system and resulting in less flow of coolant.

This means that the temperature of the air flowing through the unit will be lower and this will cause the capillary to shrink. The result will be an increased flow of coolant. This cycle is repeated continuously so that a stable air temperature is achieved.

Combined unit

This is a combined heater and fresh-air unit, prepared for installation of air conditioning. It consists of a central unit (14, Fig. 8-43), located under the dash, and air ducts and nozzles for distributing the air to the various points inside the car. All shutters for air directing are regulated by vacuum, which is taken from the engine intake manifold via a vacuum tank located under the dashboard. The four vents (15) on the dash are manually adjustable and can be turned, opened and closed irrespective of each other and by a knob in the center of the valve (16). An electric motor (13) located in the central unit takes care of the air circulation. This motor is provided with a through shaft and two turbine wheels (3). The cellular assembly (12) of the heater system is placed in front of the electric motor. Vehicles with air conditioning have the evaporator (9) in-

stalled in front of the heater system cellular assembly.

The combined unit is operated by two knobs and three push buttons placed on the dashboard. The right knob "FAN" (18) is the switch and speed control for the blower, and it has three speed positions.

The left control "TEMP" (25) regulates by a cable the heat control valve (1) so desired air temperature is achieved.

The air shutter and the air intake cover are turned with the help of vacuum. At each shutter there is a vacuum motor (8) which opens the shutter when actuated by vacuum. Vacuum is transmitted to the vacuum motors by pushing in the appropriate buttons on the dash. When the buttons are pushed out again, the shutters return to the closed position with the help of return springs (7).

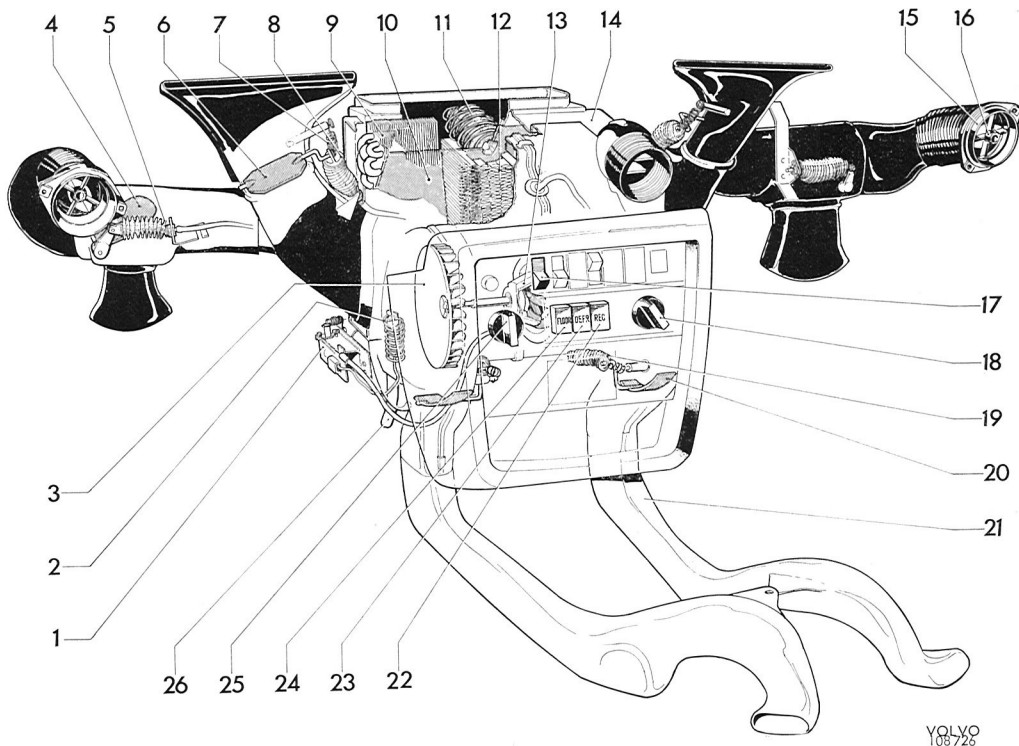

Fig. 8-43. Combined unit

- | | |
|--|---|
| 1. Heater control valve | 14. Central unit |
| 2. Capillary tube for heater control valve | 15. Blow-in valve |
| 3. Turbine | 16. Shutter knob |
| 4. Shutter, air vent left floor | 17. Air conditioning switch |
| 5. Vacuum motor | 18. Fan motor switch |
| 6. Shutter, left defroster nozzle | 19. Vacuum motor |
| 7. Return spring for vacuum motor | 20. Shutter, right air duct, rear floor |
| 8. Vacuum motor | 21. Air duct to rear floor |
| 9. Evaporator (only on vehicles with air conditioning) | 22. Knob, air intake cover |
| 10. Air intake cover | 23. Knob, defroster shutter |
| 11. Vacuum motor for air intake cover | 24. Knob, floor shutter |
| 12. Heater cell assembly | 25. Temperature controls |
| 13. Fan motor | 26. Drain hose |

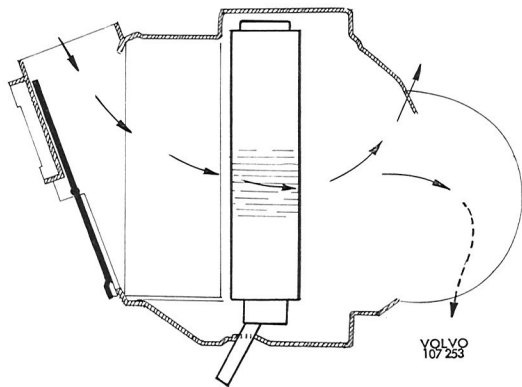

Fig. 8-44. Air circulation through system

The air flow through the vents on the dash are only regulated by the vent shutter and is not influenced by the push buttons. When all buttons are out, only fresh air is drawn into the unit (Fig. 8-44), all flow ducts are closed and the defroster effect is weak. When the button marked "FLOOR" is pushed in, full air flow is supplied to the front and rear floor together with weak defroster effect. When the middle button "DEF" is pushed in, full defroster effect is obtained while the floor ducts on the other hand are fully closed. When the right button marked "REC" is pushed in, the air intake cover is adjusted to re-circulation of the compartment air (Fig. 8-45). With the cover in this position, only a small portion of fresh air is sucked in and mixed with the compartment air. If the vehicle is provided with air conditioning, more effective lowering of the temperature inside the compartment is obtained if the re-circulation is used.

Even when the air conditioning is switched on with a switch (17, Fig. 8-43) on the dash, the air temperature is regulated by the "TEMP" control. Fig. 8-45 shows how the sucked-in air is first cooled when it passes the evaporator (1) and how it is heated, when it passes the heater cell assembly

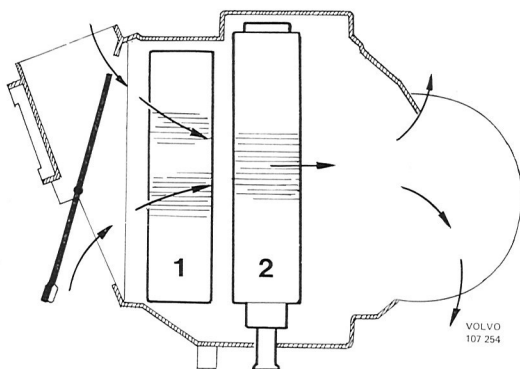

Fig. 8-45. Air circulation through system with re-circulation
1. Evaporator 2. Heater cell assembly

(2), up to the temperature adjusted by the "TEMP" control. When the air passes the evaporator, it liquifies as it cools. The moisture which condenses on the evaporator during the cooling, is drained through the two hoses (26, Fig. 8-43), which run through the transmission tunnel.

HEATER SYSTEM

The heater system in the combined unit consists of a cell assembly and a heater control valve. The cell assembly (4, Fig. 8-46) is located in the central unit while the heater control valve (1) is placed underneath.

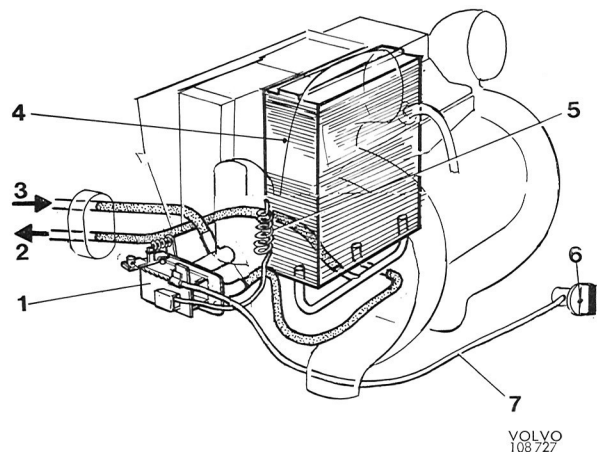

Fig. 8-46. Heating system

- | | |
|-------------------------|--|
| 1. Heater control valve | 5. Capillary tube for heater control valve |
| 2. Water hose, output | 6. TEMP control |
| 3. Water hose, input | 7. Control cable |
| 4. Cell assembly | |

The heater control valve is regulated via a cable by the "TEMP" control (6). Its function is similar to that of the standard heater valves.

COOLING SYSTEM ("Air Conditioner")

Design

The cooling system in the unit is of the compressor type, which means that the refrigerant is circulated by a compressor. The system is divided up into the following main components: condenser (5, Fig. 8-47), compressor (3), drier (4), thermostatic expansion valve (2) and evaporator (1). The evaporator and expansion valve are placed in front of the heater system cell assembly inside the passenger compartment and the other components in the engine compartment.

The evaporator consists of a tube provided with flanges for taking up heat. The thermostatic expansion valve is connected to the inlet pipe on the evaporator. It is the function of the valve to regulate the flow of refrigerant to the evaporator. The two-cylinder piston compressor is provided with an

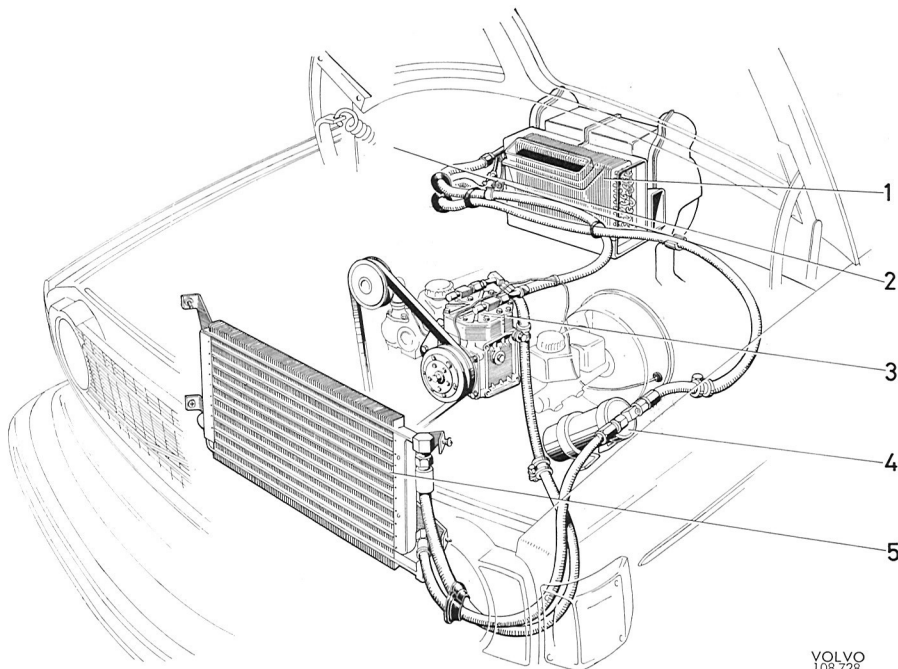

Fig. 8-47. Cooling system

1. Evaporator
2. Expansion valve
3. Compressor
4. Receiver-drier
5. Condenser

VOLVO
108 728

electromagnetic clutch and is driven by a pulley belt from the car engine. The condenser consists of tubes with cooling flanges and it is placed in front of the car's standard radiator. The function of the receiver-drier is to absorb the moisture which can remain in the system and to store the refrigerant for the evaporator. Refrigerant hoses are used for conveying the refrigerant between the various components. They are provided with tapered pipes and unions at the ends.

The unit is started by the switch (4, Fig. 8-48) on the instrument panel inside the vehicle. When the current is switched on, the electromagnetic clutch and the compressor (5) start operating. A cut-out thermostat (8) is installed at the evaporator in order to prevent it from icing.

In order to eliminate risk of engine stop, when the engine is idling and the compressor is engaged, there is a solenoid (6) connected to the fuel system. When the compressor starts, the solenoid opens an overflow channel so that the engine idling speed rises.

Function

The various components in the air conditioning unit form with their hoses a closed system where the refrigerant is kept in circulation by the compressor. The actual cooling process has no direct beginning or end in the unit but works continuously with the refrigerant changing between gas and fluid due to the changes in temperature and pressure in the system.

In order to explain the cooling process that takes place, it is suitable to start with the thermostatic expansion valve, usually called the TEV (1, Fig. 8-49). Before the TEV, the refrigerant is in liquid form and at high pressure. When it flows into the inlet pipe of the evaporator, where there is lower pressure (created by the suction effect of the compressor), the temperature of the refrigerant immediately drops and it is converted to partly vapour, partly fluid. Since the boiling point of the refrigerant is at -32°C (-26°F) at normal air pressure, it starts to boil and changes to vapor in the evaporator coil (3), while it absorbs heat from the warm air which the fan motor (2) blows round the pipeline. Due to the fact that heat is absorbed from the air, it becomes colder. It is this cold air which is blown out through the air ducts into the compartment. In the evaporator coil, the latent heat has caused the refrigerant to convert

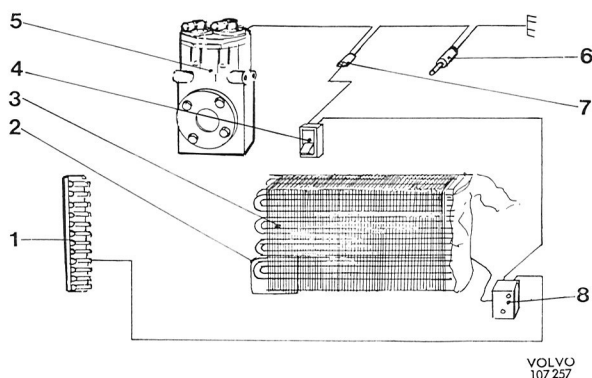

VOLVO
107 257

Fig. 8-48. Wiring diagram for air conditioning

1. Fuse box
2. Thermostat capillary tube
3. Evaporator
4. Switch
5. Compressor
6. Solenoid
7. Connector
8. Thermostat

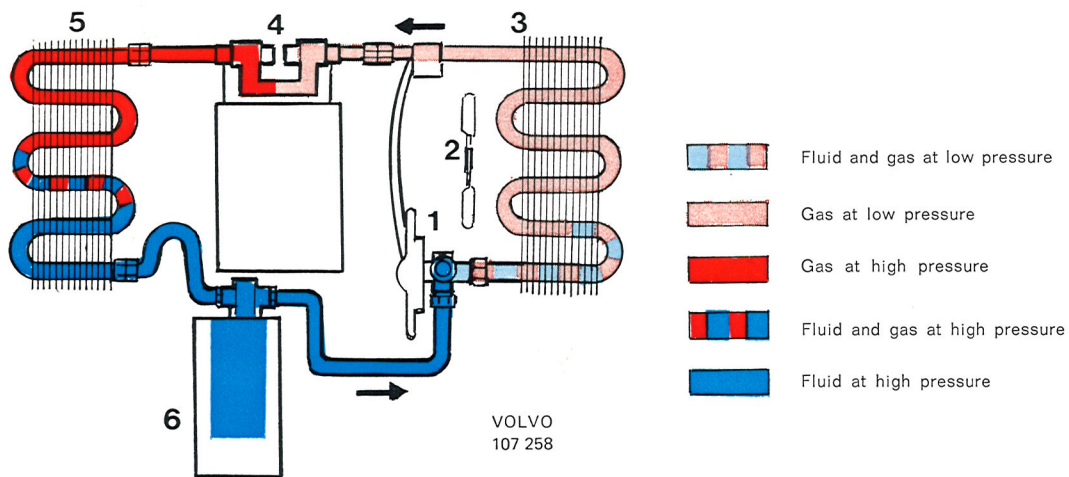

Fig. 8-49. Refrigerant circulation in air conditioning system

- | | |
|--------------------|-------------------|
| 1. Expansion valve | 4. Compressor |
| 2. Fan | 5. Condenser |
| 3. Evaporator | 6. Receiver-drier |

to a gaseous form, without any change in temperature. Before the refrigerant reaches the end of the coil, it absorbs, however, more heat and the gas temperature rises. This heat is called superheat, and it is that which regulates the function of the TEV, which will be described later on.

From the evaporating unit, the gaseous refrigerant is sucked to the compressor (4) where it is compressed to a high pressure and high temperature. The hot refrigerant is thereafter conveyed under pressure to the condenser coil (5). The coil is provided with cooling flanges around which it is cooled by air with the help of the car cooling fan. Due to the fact that heat always moves from a warmer to a colder object, the hot refrigerant will emit a part of its heat to the colder air. Since the hot gaseous refrigerant loses a part of its heat, it starts condensing and changes to a fluid.

The condensed refrigerant which has changed to a fluid, is conveyed at high pressure and high temperature further to the receiver-drier (6). The receiver-drier contains a desiccant which not only absorbs moisture from the refrigerant but also stores the refrigerant. From the receiver-drier the refrigerant is conveyed further via the TEV to the evaporator, so the cycle is complete.

In order to clarify the function of the TEV, whose purpose is to regulate the amount of refrigerant which is to be supplied to the evaporator, a more detailed description is required. A spring-loaded ball valve is located in the valve body and this valve is actuated by a diaphragm via push rods. In its turn, the diaphragm is influenced by a gas-filled capillary tube, which is fixed to the outlet pipe of the evaporator. At a certain point, the gas in the

evaporator, due to the latent heat, reaches the same temperature as the refrigerant as when it enters the evaporator. If more heat is absorbed by the gas it is called, as mentioned previously, superheat. It is this superheat which the gas in the capillary tube feels and absorbs a part of. When the gas absorbs heat, it expands and presses against the diaphragm. This causes the diaphragm to actuate the push rods so that the spring force is overcome and the ball valve opens. When the ball valve opens, the refrigerant flows into the evaporator (Fig. 8-50).

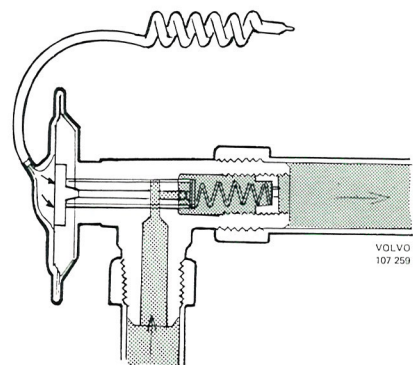

Fig. 8-50. Expansion valve in open position

When refrigerant flows into the evaporator, it becomes colder and the superheat reduces. The gas in the capillary tube is affected by this difference so that the pressure against the diaphragm reduces and the ball valve closes further supply of the refrigerant (Fig. 8-51).

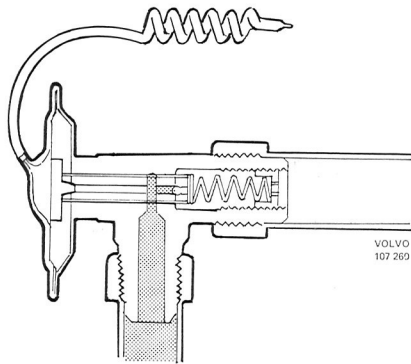

Fig. 8-51. Expansion valve in closed position

By the TEV regulating in this way the right amount of refrigerant to the evaporator, it is possible for

the evaporator to cope with the various heat loads and produce an even temperature for the cooled air.

Belonging to the unit control system is the cut-out thermostat, whose function is to prevent evaporator icing. The thermostat is placed at the evaporator and is provided with a capillary tube (2, Fig. 8-48) which is inserted between the evaporator fins (3). When the vapor temperature has dropped to $+3^{\circ}\text{C}$ (37°F), this actuates the capillary tube thermostat so that current to the compressor clutch is cut off and the compressor stops. When the temperature of the evaporator again rises, this cuts in the current and the compressor starts working again.

SERVICE PROCEDURES

SEATS

Adjusting front seats

1. The inclination of the seats is adjusted with the eyebolt at the front edge of the seat. Slacken the adjusting screw and adjust the eyebolt to the desired position.
2. The height of the seat is adjusted by attaching the rail to a suitable hole in the bracket.

Removing front seats

Unsnap the fasteners which hold the seat cushion to the frame and remove the seat cushion. Remove the four nuts for the slide rails. Lift off the seat.

SEAT RECLINING MECHANISM REPLACEMENT

Removal

In order to get the mechanism aligned correctly, the seat reclining mechanisms on both sides must be removed, even if only one is being replaced.

1. Remove the cover (14, Fig. 8-54) by pressing it out through the hole in the hand wheel. See Fig. 8-52.
2. Remove the hand wheel (12, Fig. 8-54) by turning the lock (13) counter-clockwise as shown in Fig. 8-53.



Fig. 8-52. Cover removal

VOLVO
108190



Fig. 8-53. Hand wheel removal

VOLVO
108191

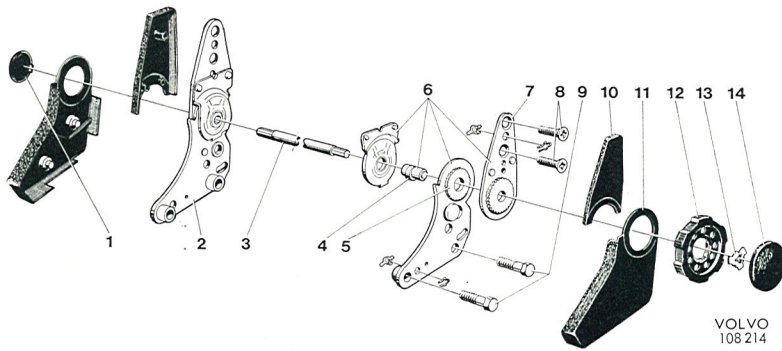

Fig. 8-54. Seat reclining mechanism

- | | |
|---------------------|---------------------|
| 1. Cover | 8. Retaining screws |
| 2. Bracket | 9. Retaining bolts |
| 3. Shaft | 10. Plastic cover |
| 4. Eccentric | 11. Plastic cover |
| 5. Gear | 12. Hand wheel |
| 6. Lever unit | 13. Lock washer |
| 7. Upper lever part | 14. Cover |

3. Remove the plastic covers (10 and 11, Fig. 8-54).
4. Remove the screws (8 and 9, Fig. 8-54) and remove the lever unit.
5. Use a screwdriver to remove the cover (1, Fig. 8-52) and the plastic covers from the bracket (2).
6. Remove the screws and the bracket.
The seat reclining mechanism cannot be repaired and should be replaced as a unit.

5. Press on the plastic covers.
6. Install the hand wheel by turning the lock clockwise, as shown in Fig. 8-56.
7. Press on the hand wheel cover.

Installation

1. Make a template for alignment of the seat reclining mechanism, see Fig. 8-55. Use a screwdriver to align the mechanisms according to the template.

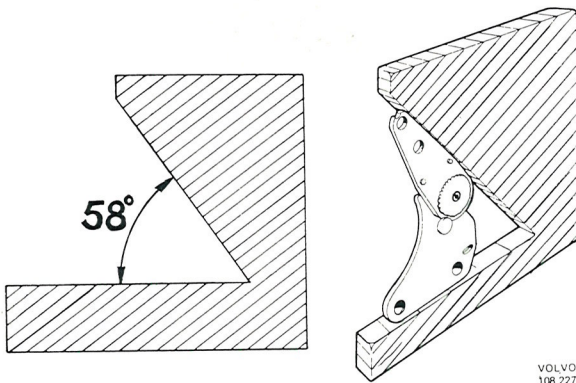

Fig. 8-55. Template, lever adjustment

2. Install the shaft in the bracket square hole and attach the mechanism to the seat back with the screws 8, Fig. 8-54.
3. Attach the lever with the 8-edged hole on the shaft in a position where the lever holes are aligned to the nuts in the seat back. Attach the lever to the seat back with the screws 8, Fig. 8-54.
4. Attach the seat back with the mechanisms to the seat frame with the screws 9, Fig. 8-54.

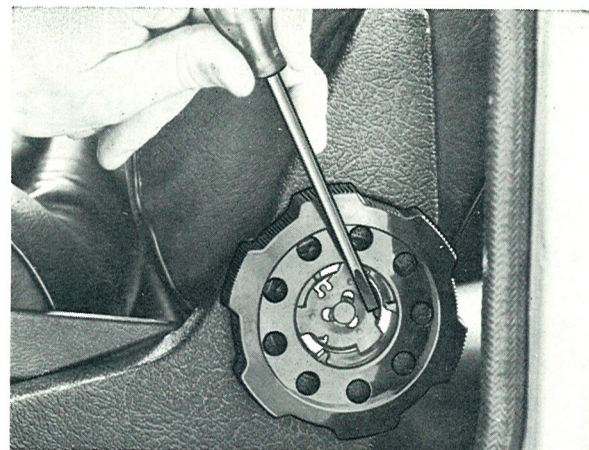

Fig. 8-56. Hand wheel installation

REPLACEMENT OF DRIVER'S SEAT HEATING DEVICE

Seat cushion pad

1. Unsnap the fasteners, lift the seat cushion and disconnect the electrical wires at the connectors.
2. Place the cushion upside down on a table.
3. Remove the upholstery retaining clamps. Use for instance two diagonal cutting pliers.
4. Remove the wire from the upholstery sides and unfold the upholstery.
5. Pull out the heater pad.
6. Install the new heater pad.
7. Route the wires through the splice in the seat front upholstery and out through the splice in the seat cushion underside upholstery, Fig. 8-57.

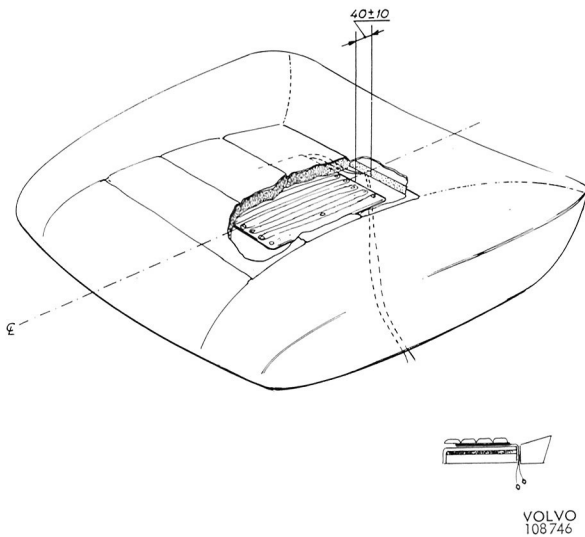

Fig. 8-57. Measurements, heater pad installation, seat cushion

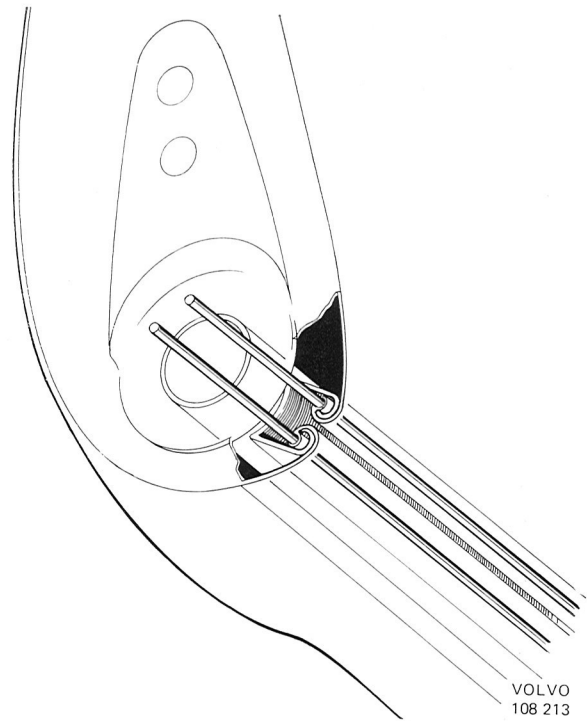

Fig. 8-58. Attachment of upholstery at the retaining moulding

Seat back pad

1. Unsnap the fasteners, lift the seat cushion and disconnect the electrical wires at the connectors.
2. Remove the seat cushion.
3. Move the seat to its forward position.
4. Remove the left side seat reclining mechanism (see separate instruction). Do not change the position of the mechanism after removal.
5. Remove the right side seat reclining mechanism at the seat back. Lift out the seat back and place it upside down on a table.
6. Remove the upholstery locking wires, Fig. 8-58. Remove the seat back pouch and lift up the upholstery from the retaining moulding.
7. Put the seat back on the side. Push the hands in under the upholstery, one on the front side, one on the rear side, and unhook the heated pad from the frame, see Fig. 8-59. Remove the heater pad.
8. Install the new heater pad and re-hook the heater pad to the frame.
9. Lay the seat with the rear side up. Route the heater pad wires so they protrude at the lower rear edge.
10. Install the locking wires in the upholstery channel and hook the upholstery in the retaining moulding, see Fig. 8-58. Install the seat back pouch and lock the upholstery with the seat back pouch clips.

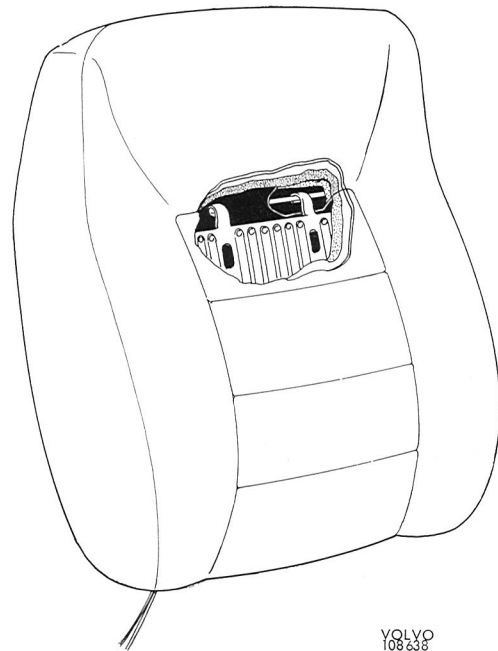

Fig. 8-59. Seat back heater pad attachment

11. Align the seat against the rear side reclining mechanism and fit the shaft to the bracket. Tighten the mechanism.
12. Install left side mechanism, see separate instruction.

13. Re-connect the electrical wires.
 14. Re-install the seat cushion.
- NOTE: If the mechanism positions have been changed during the work, they must be adjusted with a template (see separate instruction).

Thermostat

1. Remove the seat heater pad (see separate instructions).
2. Disconnect the thermostat wires. Remove the thermostat.
3. Install the new thermostat in the heater pad and connect the electrical wires.
4. Install the heater pad (see separate instructions).

REPLACING HEADLINING

Volvo Standard Times Op. No. 85104

1. Remove the interior light, sun visors, and rear view mirror.
2. Pull down the edge of the headlining with finger and thumb on one side as shown in Fig. 8-60 so that the plastic edge can be released from its fastening in the rail.
3. Then pull down the headlining all round.



Fig. 8-60. Removing headlining

4. Take down the stretchers beginning from the back by bending them down in the middle and releasing them from the edge of the roof as shown in Fig. 8-61.

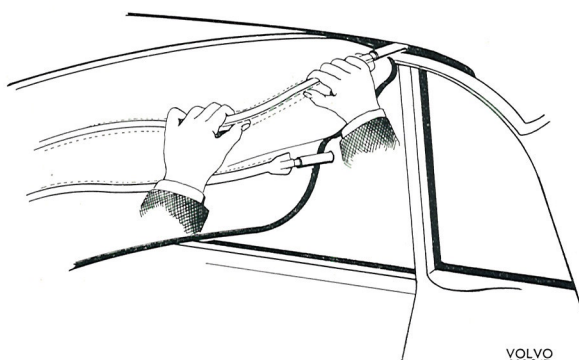

Fig. 8-61. Removing roof stretchers

NOTE: Be careful when removing and installing the stretchers. Careless handling can cause the ends to damage the roof plate.

5. Install the stretchers in the new headlining. Make sure that they are provided with rubber caps at the ends as shown in Fig. 8-62.

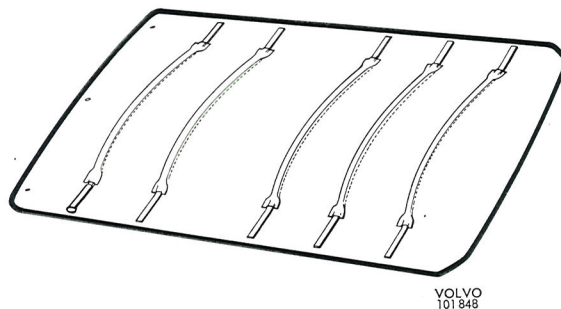

Fig. 8-62. Headling, 142 and 144

6. Install the headlining by first inserting the stretchers beginning with the front one.
7. Stretch the headlining forwards and tuck in the plastic strip at the front edge.
8. Then stretch the headlining backwards by pulling both ends of a stretcher at the same time. Begin at the front and pull on each stretcher working backwards, after which the rear plastic strip can be tucked into its groove.
9. Now pull over the headlining towards one side and tuck in the plastic strip. Then stretch the headlining over towards the other side and tuck in the plastic strip.
10. Install the interior light, sun visors and rear view mirror.
11. Any folds in the fabric can be removed by pulling the headlining in the necessary direction. The headlining then moves in the attaching rails.

INSTRUMENT AND CONTROL PANEL

Removing instrument panel

1. Disconnect the battery ground cable.
2. Remove the steering wheel (Section 6 "Replacing steering wheel") and the steering column covers.
3. Release the screws holding the switches for turn signal and wiper and thereafter the plastic casing in front of the steering wheel.
4. Remove the clasp and the holder for the horn slip ring.
5. Remove the combined instrument according to the instructions in Section 3.
6. Remove the light switch and possibly the choke control from the instrument panel.

7. Remove the steering wheel lock according to the instructions given in Section 6.
8. Take out the bulb holders in the combined instrument lights and the bulb holder in the clock.
9. Disconnect the electric cable from the clock and the harness from the lower part of the instrument panel. A clamp is situated immediately under the clock and another underneath the combined instrument to the left.
10. Remove the center panels and the defroster hoses on both sides, also the hoses between the car heater and the center air vents in the instrument panel as well as the casing for these hoses.
11. Remove both the lower screws for the control panel and then tip it back as far as the cables permit.
12. Disconnect the electric wires to the glove locker light by opening the locker lid and pulling the entire light inwards. The wires are disconnected in this position.
13. Remove the outer impact protections. These are removed by pulling them straight out backwards.
14. Remove the screws securing the instrument panel. There are three on each side of the firewall, two underneath and one which is visible when the impact protections have been removed. A further two attaching screws are located above the upper attaching screws for the control panel.
15. Release the instrument panel from its attachment in the dashboard by pulling it backwards and at the same time lifting it over the control panel and the support legs.
16. Lift out the instrument panel.
7. Install the steering wheel lock according to the instructions in Section 6.
8. Install the switch for the lighting and choke control if it has been removed.
9. Install the combined instrument according to the instructions in Section 3.
10. Install the holder for the horn device slip ring onto the steering column and then the bracket clasp.
11. Install the control for the directional indicator switch and the windshield wipers, also hook up the electric cables to them.
12. Install the casings over the steering column.
13. Install the steering wheel, see Section 6.
14. Hook up the electric cables to the glove locker lighting.
15. Install the defroster hoses and the center panels.
16. Install the lower attaching screws for the control panel.
17. Connect the battery ground cable and check the function of the instruments and lamps in connection with this installation.

Glove locker

Replace glove box=Volvo Standard Times Op. No. 85167

The glove locker is removed by removing the four attaching screws and releasing the glove locker lid stopper. Then lift out the lid with hinges. The locker can then be taken out. Disconnect the electric cables from the bulb and switch. When re-installing the glove locker, it should be adjusted into position before the screws are finally tightened.

NOTE: If the vehicle is equipped with a combination heater unit, also the impact protection and the member under the glove locker must be removed.

Installing instrument panel

1. Check to make sure that the rubber bushings in the dashboard are not damaged. Otherwise replace them.
2. Place in the instrument panel with the guide pin in the rubber bushing and screw tight to the cowl sides and support legs.
3. Install on the impact protections.
4. Install the hoses with casing between car heater and the center air vents in the instrument panel.
5. Install the bulb holder for the clock and hook up the electric cable to the clock.
6. Install the bulb holder to the combined instrument lighting strip and fix the cable harness to the instrument panel by the clamp.

Control panel

Removal of the control panel can be started once the battery ground cable has been disconnected. Thereafter remove the panel attaching screws and lift the panel forwards until the wire connections are accessible. Note that the panel is attached by six screws. Two are underneath the panel. Mark the connections and disconnect them from their terminals. The panel can then be lifted out.

When re-installing, place the panel first in a suitable position, re-connect the wires and then place the panel in position. Thereafter screw tight and re-connect the battery ground cable.

HEATING SYSTEM

General instructions

The following instructions deal with those parts which are common to both the standard heating system and the combination type.

REPLACING INNER AIR VENTS IN INSTRUMENT PANEL

Before starting repairs, disconnect the battery ground cable.

The work on the inner air vents differ with regard to the standard system and a combination system.

1a. Combination system: Remove the glove locker and clock.

See corresponding sections in Section 8 and 3 resp.

b. Standard system: Remove the right center panel.

2. Remove the hoses between heater and vent.

3. Release the attaching screws for the respective vents and take out the vents.

NOTE: When replacing the inner left vent on vehicles with the combined system, the right vent must first be removed.

REPLACING OUTER AIR VENTS IN INSTRUMENT PANEL

1. Disconnect the hose from the vent.

2. Release the attaching screws for the vent and take out the vent.

Installing is in reverse order.

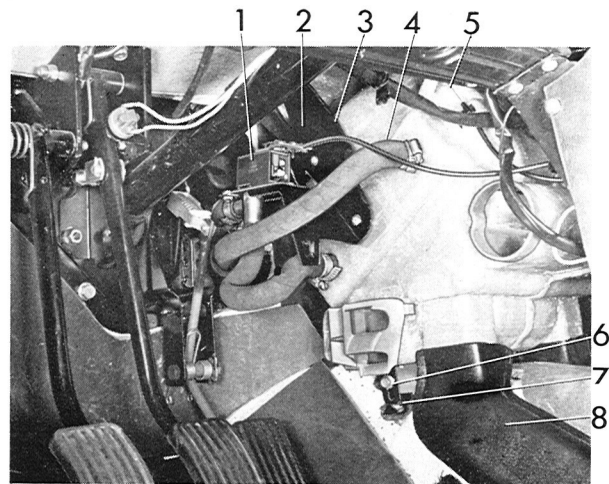

YOLVO
107319

Fig. 8-63. Car heater in vehicle, standard system

- | | |
|-------------------------------------|----------------------------------|
| 1. Heater control valve | 5. Control for air-mix |
| 2. Bracket | 6. Lower bracket |
| 3. Control for heater control valve | 7. Tunnel bracket |
| 4. Pressure hose | 8. Air ducting to rear seat area |

Standard heating system

REMOVING CAR HEATER

Before starting any work on the car heater, disconnect the battery and drain the coolant.

Left-hand side (Fig. 8-63):

1. Remove the center panel and the hose between the car heater and the defroster nozzle.
2. Fold up the mat, disconnect the front and rear attaching screws for the rear seat heater duct (8) and release the duct from the car heater.

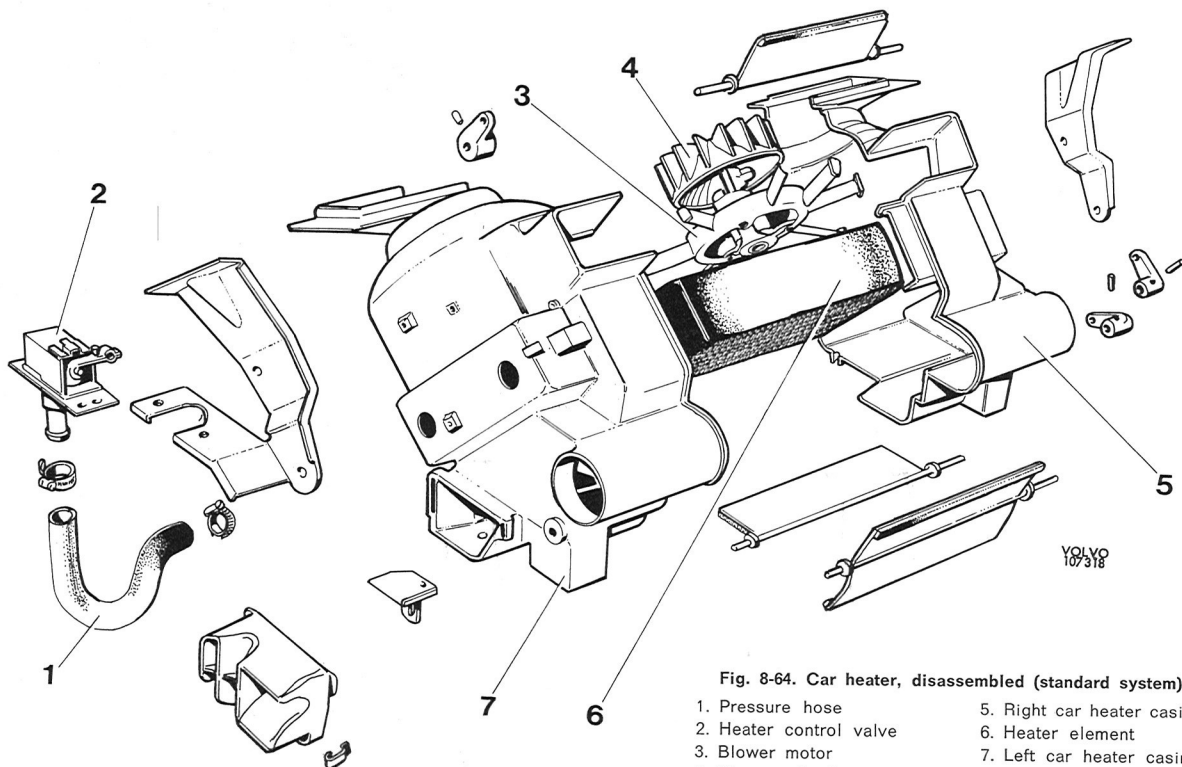

YOLVO
107318

Fig. 8-64. Car heater, disassembled (standard system)

- | | |
|-------------------------|----------------------------|
| 1. Pressure hose | 5. Right car heater casing |
| 2. Heater control valve | 6. Heater element |
| 3. Blower motor | 7. Left car heater casing |
| 4. Blower wheel | |

3. Release the controls for air-mix (5) and the heater control valve (3) from their shutters.
4. Disconnect the heater hoses at the tubes on the inside of the firewall. Plug the hoses and pipes with a suitable plug so that coolant does not run out onto the mat.
5. Release the upper attaching screws securing the bracket (2) to the dashboard and thereafter the lower bracket (6) from the car heater and tunnel bracket (7).

Right-hand side:

1. Remove the glove locker (see page 8:29).
2. Disconnect the defroster and floor heating controls.
3. Disconnect the blower wires from the switch contact plate.
4. Remove the center panel, fold the mat out of the way. Release the front attaching screw for the rear seat heater duct and release the duct from the car heater.
5. Remove the attaching screw securing the lower bracket of the car heater to the tunnel console.
6. Release the attaching screws for the upper bracket and lift off the bracket.
7. Remove the hose between the inside air vents and the car heater.
8. Disconnect the evacuation hose (it is between the car heater and the dashboard) from the car heater, move out the heater to the right and lift it out.

DISASSEMBLING CAR HEATER

Place the car heater on a work bench with the heater control valve upwards. Remove the spring clamps securing the heater and take off the top cover with control valve and heater element.

REPLACING BLOWER MOTOR

Remove the car heater and disassemble it according to the previous instructions. Lift out the motor and replace it with a new one. Place the new blower motor in the heater housing so that the support leg without foot points to the output for the defroster channel. Thereafter assemble the heater and install it in the vehicle according to the instructions below.

REPLACING HEATER CONTROL VALVE

Remove the heater and place it on a work bench with the valve facing upwards. Disconnect the water hose from the valve and remove the attaching screws securing the valve to the bracket. Then remove the spring clamps and lift the upper section out of the way with valve and element. Disconnect

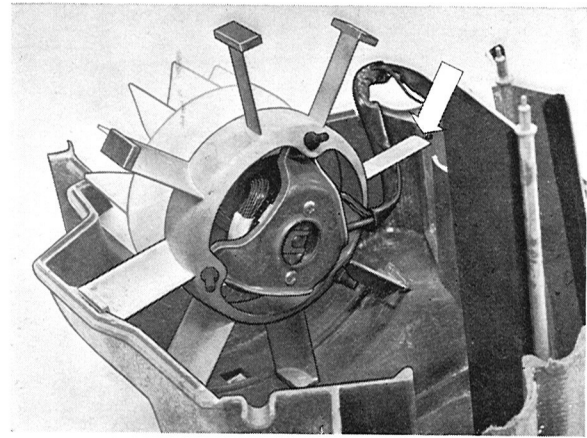

VOLVO
107319

Fig. 8-65. Blower motor location in car heater housing

the capillary tube from the element and lift off the valve. Position the new valve and secure the capillary tube to the element (Fig. 8-66). Assemble the heater according to the following instructions and screw the valve tight to the bracket. Finally, install the water hose.

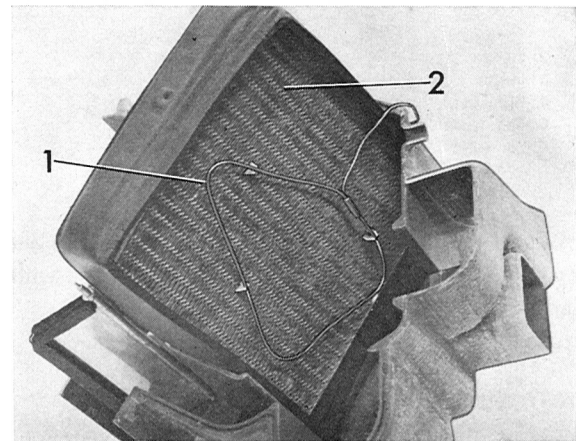

VOLVO
107320

Fig. 8-66. Attaching capillary tube in heater element

1. Capillary tube 2. Heater element

REPLACING HEATER ELEMENT

Remove the heater and disassemble it according to the previous instructions. Disconnect the capillary tube from the element and lift off the element. Move over the foam plastic to the new heater element and place it in position in the heater. Then fix on the capillary tube (see Fig. 8-66). Assemble the car heater and fit it in the vehicle according to the instructions below.

ASSEMBLING CAR HEATER

Place the right heater cover with blower motor on a work bench. Check that the location of the motor is correct (see under "Replacing blower motor"). Place the left cover with element and heater con-

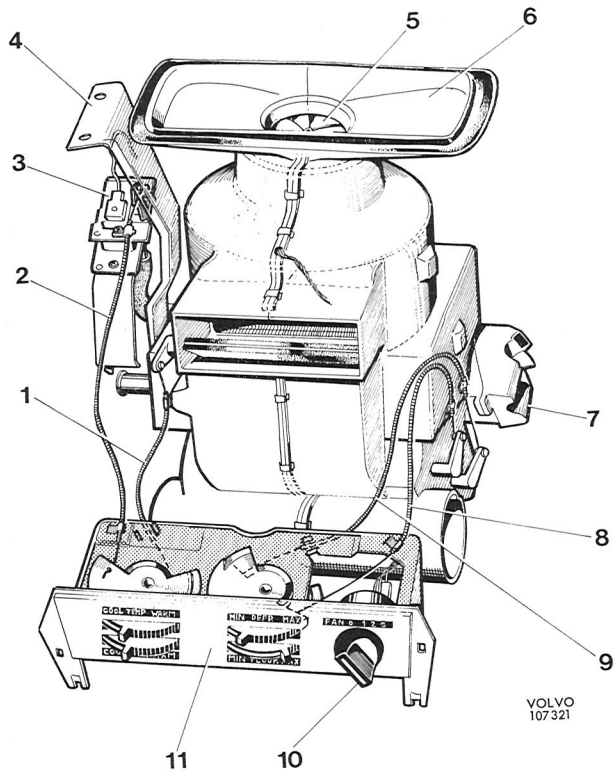

Fig. 8-67. Car heater, standard system, with controls

- | | |
|-------------------------|----------------------------|
| 1. Control for air-mix | 7. Air vent, floor |
| 2. Heater control | 8. Defroster control |
| 3. Heater control valve | 9. Air vent control, floor |
| 4. Bracket | 10. Blower switch |
| 5. Fan wheel | 11. Control plate |
| 6. Air intake | |

trol valve over the right one and put them together by means of the spring clamps. Seal the joint without spring clamps with sealing compound.

INSTALLING HEATER

Installing is in reverse order to removal. Particular attention should, however, be paid to the following points:

1. Check that the rubber seal for the air vent is correctly located.
2. Connect the blower motor ground cable to the upper attaching screw in the upper, right-hand bracket.

Fill coolant and re-connect the battery.

Combined unit

REPLACING TURBINE WHEEL, LEFT-HAND SIDE

1. Disconnect the battery ground cable.
2. Fold the floor carpet to the one side and remove the side panels from the central unit.
3. Remove the screws (2, Fig. 8-68) for the control plate support legs on both sides, and move the plate as far back on the transmission tunnel as the electric wires permit.

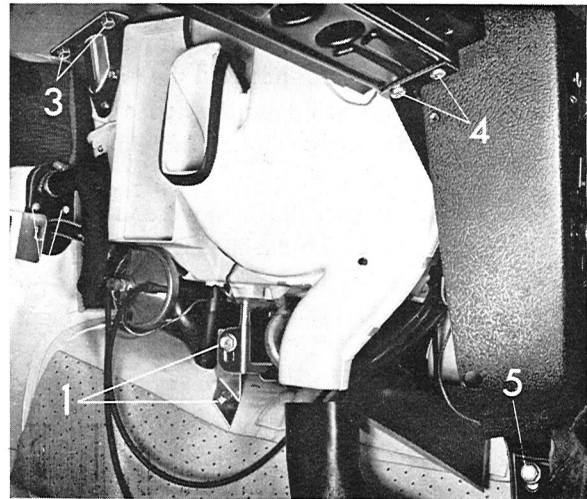

Fig. 8-68. Central unit, left-hand side

- | | |
|-------------------------------|----------------------------------|
| 1. Screws for bottom bracket | 4. Upper screws for support legs |
| 2. Screws for connection pipe | 5. Lower screw for support legs |
| 3. Screws for upper bracket | |

4. Remove the attaching screw for the rear floor air duct so that the duct can be disconnected from the central unit.
5. Remove the combined instrument (see instructions, Section 3).
6. Disconnect the vacuum hose from the left defroster nozzle's vacuum motor and remove the defroster nozzle and air duct to the left air vent.
7. Remove the air hose between the central unit and the left, inner, air vent.
8. Remove the clamps on the central unit outer end (Fig. 8-69) and remove the end.

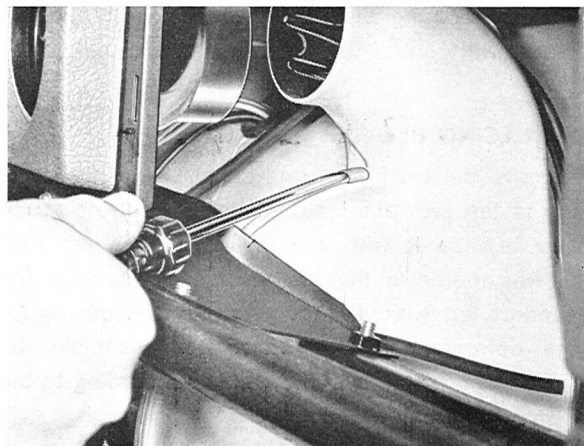
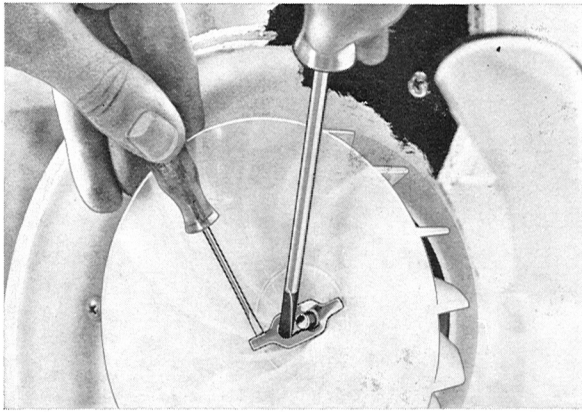

Fig. 8-69. Removing clamps for outer end

9. Remove the turbine wheel locking with the help of the two screwdrivers (Fig. 8-70), and remove the turbine.
10. Place the new turbine wheel on the shaft and install the locking.



VOLVO
107 263

Fig. 8-70. Removing locking for turbine

11. Install the outer end and check at the same time that the heater control valve capillary tube with rubber grommet is properly installed in the air duct. Use clamps, part No. 676234, for the end and install them with pliers as shown in Fig. 8-71. Concerning location of the clamps, see Fig. 8-72.

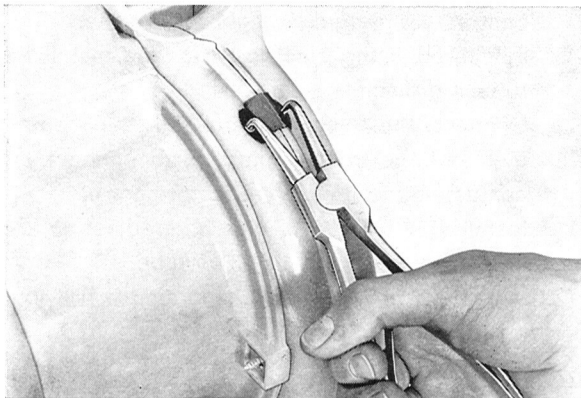

VOLVO
107 264

Fig. 8-71. Installing clamps for outer end

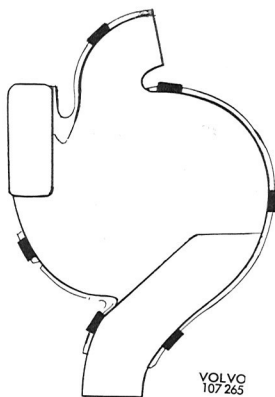

VOLVO
107 265

Fig. 8-72. Placing clamps for outer end

12. Connect battery ground cable and make a function test.

13. Disconnect the battery ground cable from the battery.
14. Install the air duct between the central unit and the air vent.
15. Install the defroster nozzle and air duct and connect up the vacuum hose.
16. Install the combined instrument (see instructions, Section 3).
17. Install the air duct to the rear floor.
18. Place the control plate and support legs in position and screw tight the support legs.
19. Put back the floor mat and install the side panels.
20. Re-connect the battery ground cable.

REPLACING TURBINE WHEEL, RIGHT-HAND SIDE

1. Perform points 1 to 4 under "Replacing turbine wheel, left-hand side".
2. Remove right side panel, insulation panel, impact protection and glove locker lid, Fig. 8-73.

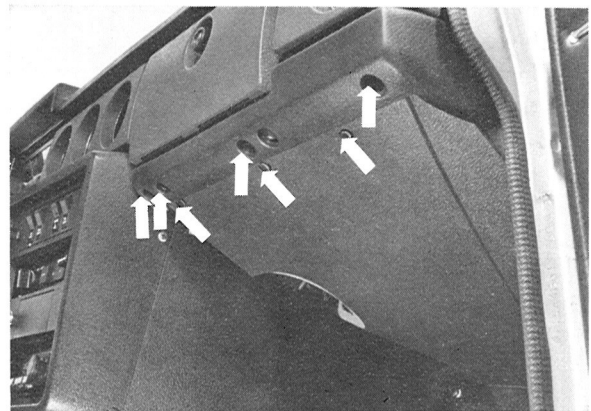

VOLVO
108 729

Fig. 8-73. Removing panels and impact guard

3. Remove the member under the glove locker, and glove locker complete with light, see Fig. 8-74.

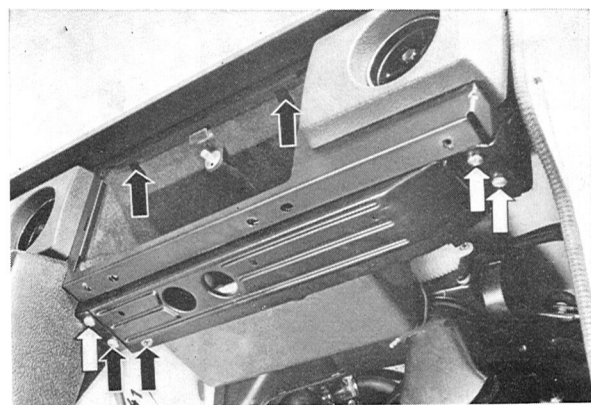

VOLVO
108 730

Fig. 8-74. Removing lower member and glove locker

4. Disconnect the vacuum hose from the right defroster nozzle vacuum motor and remove the defroster nozzle and the air duct to the right air vent.
5. Remove the air duct between the central unit and the right inside air vent.
6. Remove the clamps on the central unit outer end (Fig. 8-69), and remove the end.
7. Remove the turbine wheel locking with the help of two screwdrivers (Fig. 8-70) and remove the turbine.
8. Place the new turbine wheel on the shaft and install the locking.
9. Install the outer end. Use clamps, part No. 676234, which are installed with pliers, see Fig. 8-71. Regarding the location of the clamps, see Fig. 8-72.
10. Connect battery ground cable and make a function test.
11. Disconnect battery ground cable.
12. Install the hose between the central unit and the air vent.
13. Install the defroster nozzle and the vacuum hose.
14. Install glove locker, member, impact protection and insulation panel.
15. Perform points 17 to 20 under "Replacing turbine wheel, left-hand side".

REPLACING BLOWER MOTOR

Volvo Standard Times Op. No. 85406

1. Remove the right and left turbines according to previous instructions.
2. Move the heater control valve capillary tube to the one side.
3. Remove the left inner end from the central unit.
4. Remove the blower motor retainer (Fig. 8-75).
5. Disconnect the contact unit from the blower motor control and disconnect the blower motor

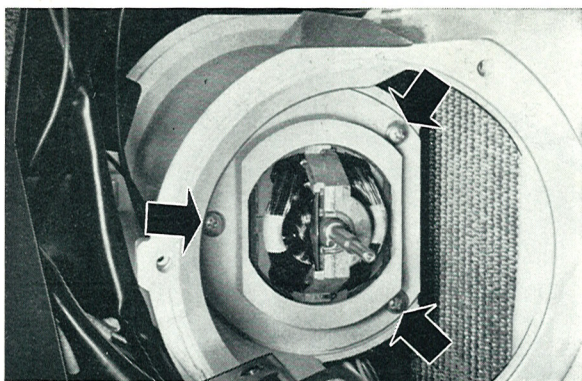

Fig. 8-75. Screws for blower motor retainer

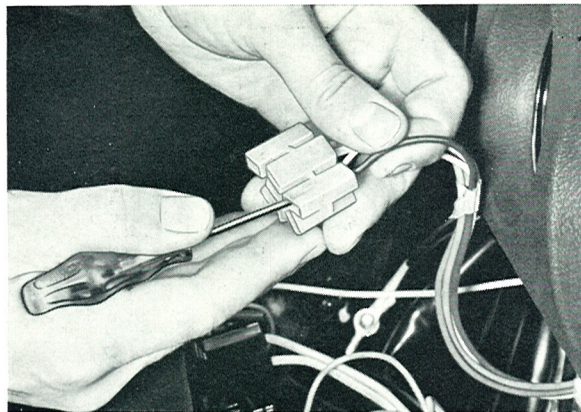

Fig. 8-76. Removing electric cables for contact unit

- electric wires from the contact unit (Fig. 8-76) and the control plate.
6. Remove the rubber grommet and pull down the electric wires through the right opening in the central unit.
7. Lift out the blower motor through the left opening.
8. Place the blower motor in position in the central unit and screw tight the retainer.
9. Pull through the electric wires and install the rubber grommet.
10. Connect the electric wires to the contact unit and the control plate, also connect the contact unit to the blower motor control.
11. Install the inner left end and adjust in the heater control valve capillary tube.
12. Install the turbine wheels according to previous instructions.

REMOVING CENTRAL UNIT

The points in brackets apply only to vehicles equipped with air conditioning.

1. Drain the coolant.
2. Disconnect battery ground cable.
3. Remove the heater system's water hoses from the joint pipes in the firewall, and plug the pipes (Fig. 8-77).
4. Remove clamps for the hoses to the evaporator and remove the firewall door without loosening the hoses to the evaporator.
5. Remove the combined instrument (see instructions, Section 3), the air hose between the central unit and the left inner air vent, also the vacuum hose to the left defroster nozzle's vacuum motor.
6. Remove the left side panel for the central unit.
7. Fold the floor mat out of the way and discon-

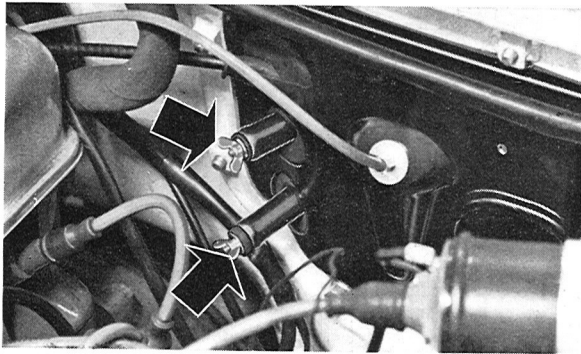

YOLVO
107269

Fig. 8-77. Installing plugs in heater system connection pipe

nect the rear floor air duct from the central unit.

8. Disconnect the joint pipes for the heater system's water hoses from the firewall.
9. Remove the upper and lower screws for the left support leg, and the screws for the upper and lower brackets, from the firewall and transmission tunnel (Fig. 8-68).
NOTE: If the screw holes for the upper bracket are slotted, the screws should only be slackened a couple of threads.
10. Remove the right side panel for the central unit.
11. Remove right insulation panel, impact protection, member under glove locker and glove locker, Fig. 8-73 and 8-74.
12. Remove the vacuum tank (Fig. 8-78), right side defroster jet, and the hose from the central unit to right center jet.
13. Fold the floor carpet out of the way and disconnect the rear floor air duct.
14. Remove the upper and lower screws for the right support leg, also the lower screws for the control panel.
15. Disconnect the ground wires from the con-

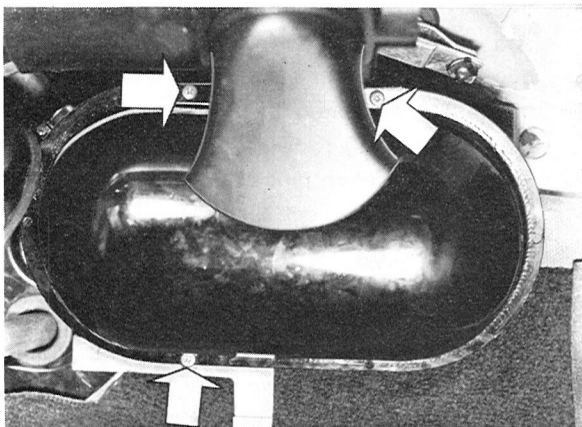

YOLVO
108731

Fig. 8-78. Screws for vacuum tank

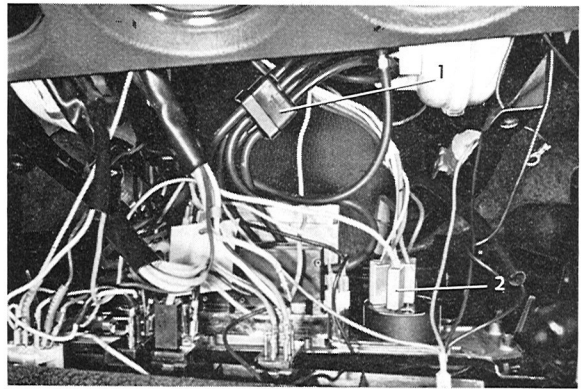

YOLVO
107270

Fig. 8-79. Control panel reverse side

1. Connector for vacuum hoses
2. Contact unit for blower motor control

trol plate and the contact unit from the blower motor control (2, Fig. 8-79).

16. Disconnect the hot wire (the thick yellow one (from the contact unit).
17. Separate the connector (1) for the vacuum hoses and disconnect the vacuum tank hose from the connector.
18. Move the control plate as far back on the transmission tunnel as the wires permit.
19. Remove the screws, for the upper and lower brackets, from the firewall and the transmission tunnel.
- (20) Disconnect the thermostat attachment (1, Fig. 8-80) from the central unit, and both the clamps (2) securing the cover to the evaporator.

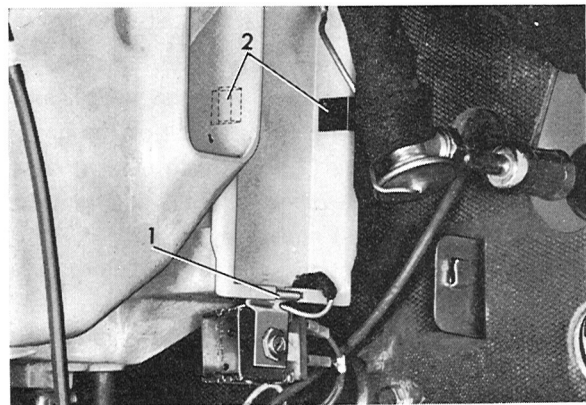

YOLVO
107271

Fig. 8-80. Cover for evaporator

1. Attaching clamp for thermostat
2. Clamps for cover

- (21) Remove the evaporator from the central unit without disconnecting any of the refrigerant hoses, and place it at the right-hand side of the cowl (Fig. 8-81).

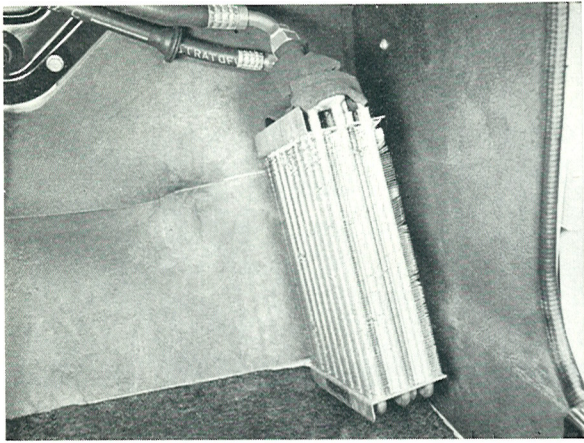

Fig. 8-81. Placing evaporator on floor

22. Remove the central unit right, outer, end (Fig. 8-69), turbine wheel (Fig. 8-70) and the inner end.
23. Lift off the seat cushion from the right front seat.
24. Lift forward the central unit.

INSTALLING CENTRAL UNIT

The points in brackets apply only to vehicles equipped with air conditioning.

1. Lift the central unit onto the right floor, and install the rubber seal for the air intake.
2. Install the right seat cushion.
3. Lift the central unit into position and insert the left, upper bracket over the screws on the dashboard. Install the right bracket screws and tighten the left ones.
- (4) Install the evaporator in the central unit. Put on the cover and secure it with the two clamps (1, Fig. 8-80), also the thermostat on the opening's lower flange (2). Seal with sealing compound round the evaporator pipes and the thermostat capillary if necessary.
5. Install the connection pipe for the heater hoses to the dashboard.
6. Install the lower tunnel brackets and the drainage hoses through the holes in the transmission tunnel.
7. Install the right, inner end and the vacuum hoses for the floor shutter.
8. Install the turbine wheel and the outer end. Fix the outer end with clamps, part No. 676234, which are installed with pliers (Fig. 8-71). The location of the clamps can be seen from Fig. 8-72.
9. Install the impact guard with member to the dashboard.

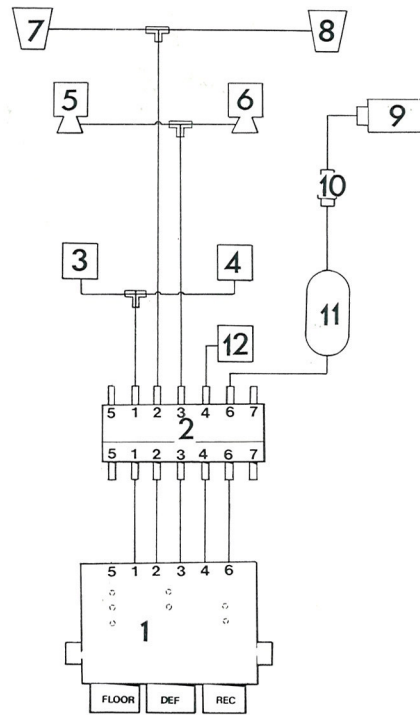

VOLVO
108732

Fig. 8-82. Lay-out diagram for vacuum control system

1. Control panel
 2. Connector
 3. Vacuum motor for rear floor, left
 4. Vacuum motor for rear floor, right
 5. Vacuum motor for front floor, left
 6. Vacuum motor for front floor, right
 7. Vacuum motor for defroster, left
 8. Vacuum motor for defroster, right
 9. Engine intake manifold
 10. Check valve
 11. Vacuum tank
 12. Vacuum motor for air intake cover
10. Install the air hose between the central unit and the right, inner air vent.
 11. Install the right defroster nozzle and connect the vacuum hose.
 12. Install vacuum tank, glove locker and member with impact protection.
 13. Install the air duct to the right air vent.
 14. Install the air ducts for the rear floor.
 15. Install the air hose to the left inner air vent and adjust the left defroster nozzle and connect up its vacuum hose.
 16. Install the combined instrument (see instructions, Section 3).
 17. Put the connection piece of the vacuum hoses together and connect the hose from the vacuum tank.
 18. Connect the hot wire (the thick yellow one) to the blower motor control contact unit, and connect the contact unit to the control.
 19. Connect the ground wires, and screw tight the instrument plate and support legs.
 20. Fold back the floor mat, install control panel, side panels and insulation panels.

21. Connect the heater system water hoses to the connection pipes on the dashboard.
- (22) Install the firewall door and clamp the refrigeration hoses in the engine compartment.
23. Fill coolant.
24. Re-connect battery ground cable and function test.

REPLACING VACUUM MOTOR FOR REAR FLOOR AIR SHUTTER

1. Disconnect the battery ground cable.
2. Remove the side panel for the central unit, right or left depending on the vacuum motor to be replaced.
3. Remove the upper and lower screws for the support legs and lift the control plate to the one side.
4. Disconnect the vacuum motor locking from the shutter shaft and attachment (Fig. 8-83), and lift forward the motor with vacuum hose.

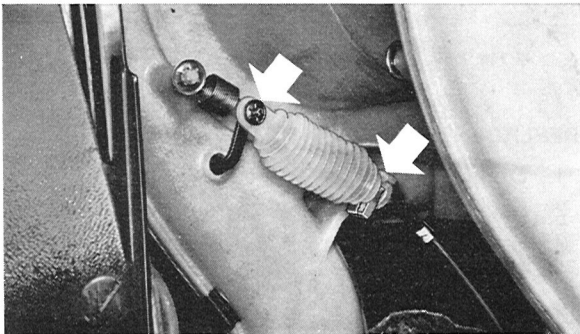

Fig. 8-83. Vacuum motor for air shutter to rear floor

5. Move the hose over to the new vacuum motor.
6. Place the vacuum motor in position and install the locks.
7. Install the control plate, support legs and side panel.
8. Re-connect battery ground cable and function test.

REPLACING VACUUM MOTOR FOR CENTRAL UNIT AIR INTAKE

The instructions apply to a removed central unit.

1. Remove the hose from the vacuum motor, and the packing round the air intake.
2. Remove the locks for the shutter shaft (1, Fig. 8-84).

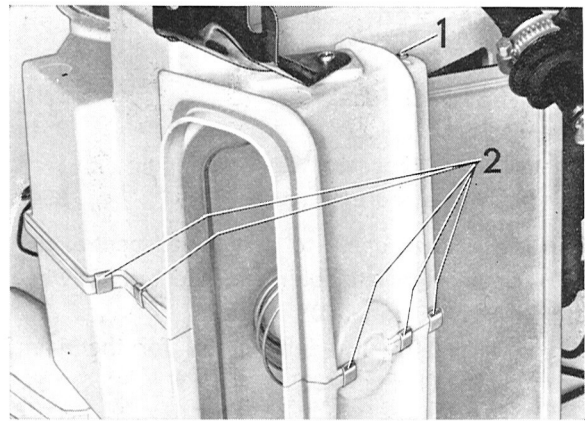

Fig. 8-84. Removing vacuum motor for air intake cover

1. Shutter shaft locking
2. Clamps

3. Remove the clamps on both sides nearest to the air intake (2).
4. Bend the central unit halves apart so far that the air shutter with vacuum motor can be released.
5. Remove the vacuum motor from the air shutter.
6. Install a new vacuum motor, and turn it so that its hose connection points to the air shutter shaft.
7. Place the air shutter with vacuum motor and spring in position on the central unit (Fig. 8-85).
8. Install the clamps for the central unit center joint and the locks for the shutter shaft.
9. Install the vacuum hose and the packing for the air intake.

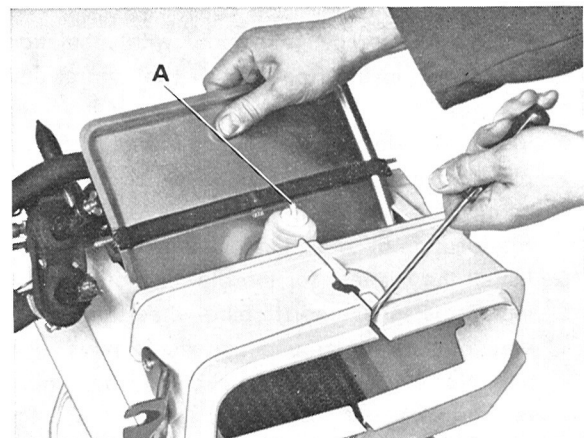

Fig. 8-85. Installing air intake cover with vacuum motor.

- Vacuum motor hoses connection
(A) should point to cover shaft

Heater system

REMOVING CELL ASSEMBLY

Volvo Standard Times	Op. No.
Heater Core, replace	85404
Heater Core, pressure test and repair (solder), heater core removed	85479

The instructions apply to a removed central unit.

1. Remove the left outer end and turbine wheel (Figs. 8-69 and 8-70).
2. Unscrew the two left screws for the tunnel bracket (1, Fig. 8-86).

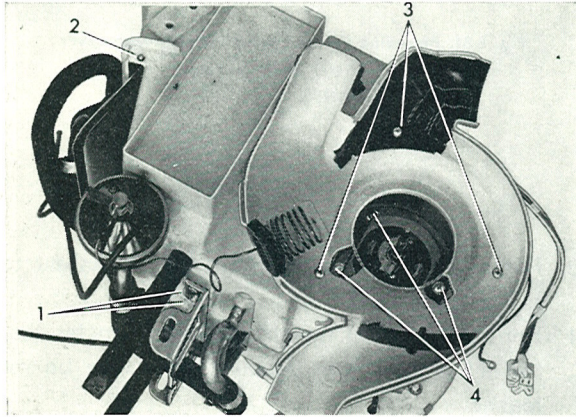

Fig. 8-86. Disassembling central unit

- | | |
|-----------------------------|-----------------------------------|
| 1. Screws for lower bracket | 3. Screws for inner end |
| 2. Shutter shaft locking | 4. Screws for blower motor holder |

3. Remove the air intake left shutter shaft locking (2).
4. Remove the screws (3) for the inner end and lift off the end.
5. Remove the screws for the blower motor retainer (4).
6. Disconnect the water hoses from the cell assembly.
7. Remove the clamps for the central unit's middle joint, lift off the left half and remove the cell assembly.
8. Place the new cell assembly with insulation in position in the right half of the central unit (Fig. 8-87).
9. Install the left half. When assembling use clamps with part No. 676234, which are fitted with pliers as shown in Fig. 8-71. Concerning the location of these clamps, see Fig. 8-88.
10. Install the retainer for the blower motor.
11. Install the inner end, turbine wheel and outer end. For the outer end use the clamps with part No. 676234, which are placed according to Fig. 8-72.
12. Install the attaching screws for the tunnel bracket.
13. Install the shutter shaft locking for the air intake.

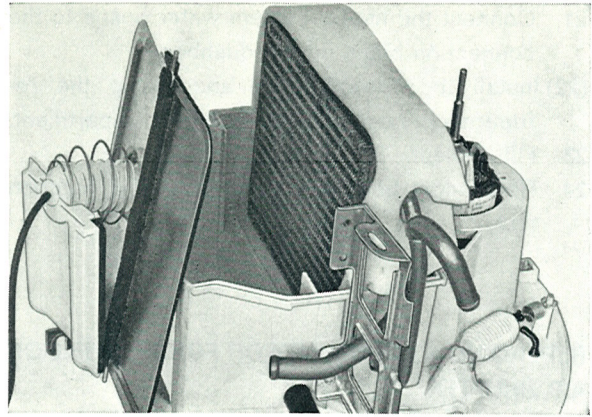

Fig. 8-87. Placing cell assembly

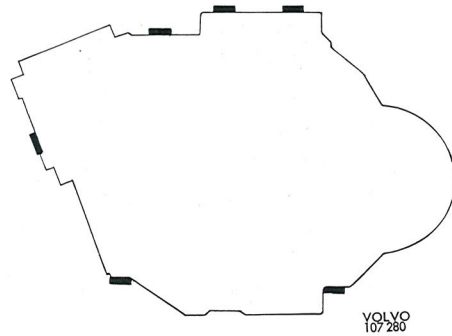

Fig. 8-88. Location of clamps for middle connector

REPLACE HEATER CONTROL VALVE

1. Drain the coolant.
2. Remove left side panel for the central unit.
3. Unfold the floor mat and put rags under the valve to protect against water spill.
4. Remove the control wire at the valve.
5. Remove the rubber grommet for the capillary (Fig. 8-89).
6. Remove the screws retaining the valve to the bracket (Fig. 8-90) and release the capillary from the air duct.
7. Disengage the valve from the water hoses.

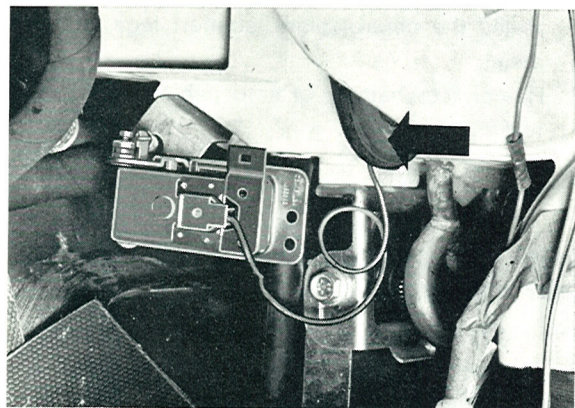
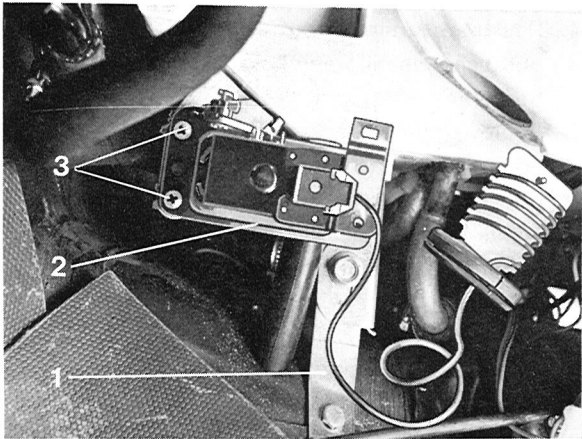

Fig. 8-89. Removing rubber grommet

8. Move the capillary rubber grommet to the new valve and re-connect the water hoses.
9. Attach the valve to the bracket.
10. Install the capillary and the control wire.
11. Fill coolant and check tightness and function.
12. Fold back the floor mat and install the side panel.



VOLVO
108734

Fig. 8-90. Replacing heater control valve

1. Capillary tube
2. Heater control valve
3. Retaining screws

COOLING SYSTEM

CHECKING OIL LEVEL IN COMPRESSOR

For checking the oil level in the compressor use a dipstick with measurements according to Fig. 8-91. Suitable material is a 3 mm (1/8") brass wire. Make ten marks 3 mm (1/8") apart at the bottom of the stick.

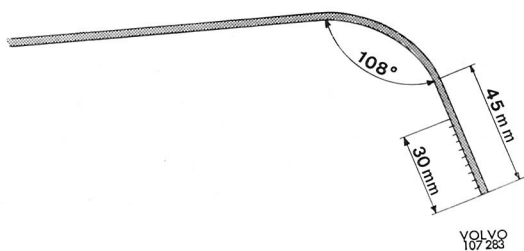

Fig. 8-91. Oil dipstick for compressor

When making an oil check with an installed compressor, it is important that the refrigerant is emptied before the oil plug is screwed out. Due to the fact that the compressor's crankcase is connected to the rest of the system, refrigerant will otherwise spurt out through the filler hole and take with it at the same time any oil left in the compressor. The refrigerant can suitably be drained by connecting the pressure gauge hoses to the service valves. Before connecting the hoses, check to make sure that the valves on the pressure gauges are closed.

NOTE: Use rubber gloves as protection when emptying the refrigerant.

The blue hose is connected to the suction side of the compressor marked "suction", the red hose to the discharge side marked "disch" and the white hose is led into an exhaust suction hose. The valves are then opened slowly otherwise there is risk of the compressor oil accompanying the refrigerant.

When checking the oil level, hold the dipstick so that the graduated part is vertical to the compressor bottom (Fig. 8-92). The correct level is 28—29 mm (1.10—1.14"). .3 dm³ (.3 qt). When filling,

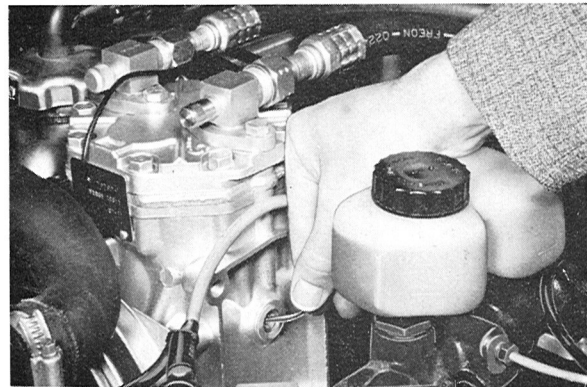

VOLVO
107284

Fig. 8-92. Check oil level in compressor

use only refrigerant compressor oil. Suitable oils are Suniso 5, BP Energol LPT 100, Shell Clavus 33, Texaco Capella E 500 or corresponding. Before screwing tight the oil plug, check to make sure that the O-ring is in good condition and that neither the plug nor the crankcase sealing surfaces are damaged. The oil plug is tightened to a torque of 5 Nm (3.5 lbf).

REPLACING COMPRESSOR CLUTCH

Volvo Standard Times Op. No. 85506

When replacing the compressor solenoid clutch, first disconnect the pulley center bolt. Thereafter

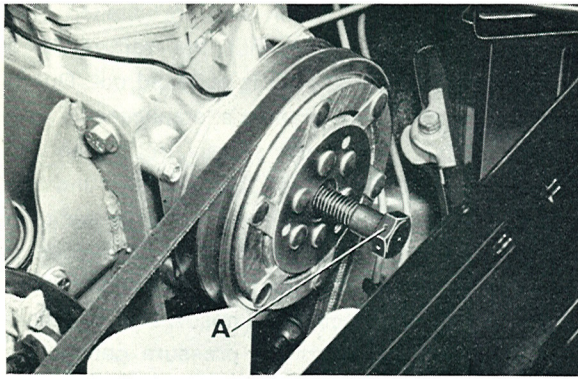

Fig. 8-93. Removing pulley
A. Bolt 5/8" UNC

VOLVO
107 285

remove the pulley with the help of a 5/8" UNC bolt, which is threaded into the center of the pulley, which is pulled off the shaft (Fig. 8-93). The solenoid is removed by the four bolts (1, Fig. 8-94).

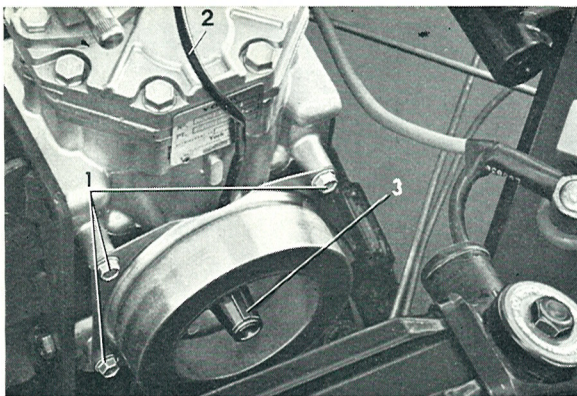

Fig. 8-94. Removing solenoid
1. Attaching screws for solenoid
2. Electric cable
3. Key

VOLVO
107 286

When installing the solenoid, turn it so that the cable (2) comes upwards. Before installing the pulley, check that the key (3) fits properly in the shaft groove. Tighten the pulley center bolt to a torque of 25—30 Nm (18—22 lbft). When tightening the center bolt, the simplest way to lock the clutch is by switching on the current and holding the pulley with the compressor belt. Then check by rotating the pulley several revolutions that it does not slip in the solenoid.

REPLACING THERMOSTAT

Volvo Standard Times Op. No. 85512

The thermostat can be replaced without emptying the system of refrigerant.

1. Release the clamps for the evaporator hoses in the engine compartment.
2. Remove the receiver-drier from its bracket and place it as near the cowl as the hose between drier and condenser permits.
3. Disconnect the thermostat attachment (1, Fig. 8-80) from the central unit and both the clamps (2) holding the cover on the evaporator.
4. Pull the evaporator out of the central unit without disconnecting any hoses and place it on the floor (Fig. 8-81).
5. Remove the thermostat with capillary.
6. Insert the new thermostat capillary in the evaporator and bend it according to the measurements in Fig. 8-95. It is important that no sharp bends are made on the capillary.

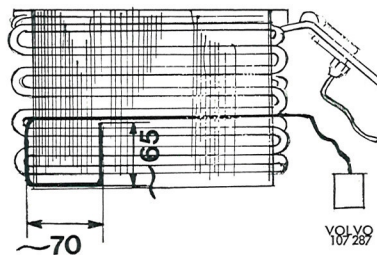

Fig. 8-95. Location of capillary tube in evaporator

VOLVO
107 287

7. Install the evaporator in the central unit. Secure the cover with the two clamps and fix the thermostat to the lower flange. With sealing compound seal all round the evaporator pipes and thermostat capillary if necessary.
8. Install the receiver-drier and clamp the refrigerant hoses securely in position in the engine compartment.

REPLACING RECEIVER-DRIER

Volvo Standard Times Op. No. 85510

(excl. leak test and charge)

Each time work is carried out on the air conditioning system involving evacuation of refrigerant, the receiver-drier should be replaced. The receiver-drier is removed by disconnecting the hose connections as well as the two bolts for the bracket (Fig. 8-96). When the receiver-drier is to be installed, it is important that it faces with the marking "OUT" towards the evaporator. Use copper washers on the hose connections.

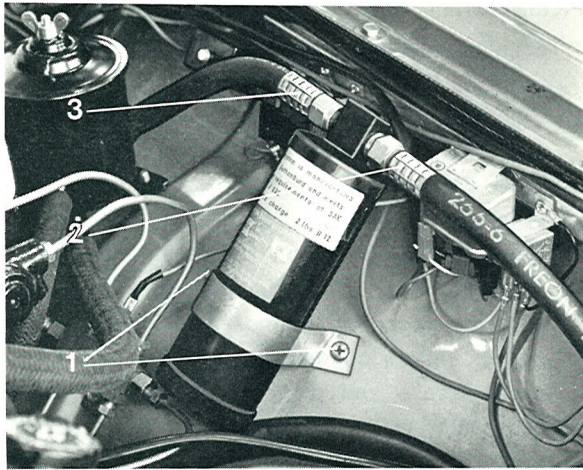

Fig. 8-96. Removing receiver-drier

1. Screw for bracket
2. Hose from condenser
3. Hose to evaporator

VOLVO
108735

FILLING REFRIGERANT

Volvo Standard Times Op. No. 85501 comprises: vacuum pump, leak test and charge Air Conditioner.

The air conditioning system may only be filled with refrigerant of type Freon 12 (dichlorodifluorometan). During the filling, which is divided up into the stages — vacuum pumping, leak test and filling — a suitable balance for weighing the refrigerant container is necessary in addition to the equipment shown in Fig. 8-4.

NOTE: Before starting the filling, check that the pressure gauges and hoses are properly tightened in the distributing piece and that the valves are closed. Check also that there are spacers on the end nipples on the hoses that are connected to the compressor and vacuum pump or refrigerant can.

VACUUM PUMPING

1. Remove the cap nuts from the compressor valves.
2. Connect the low-pressure gauge hose, the blue one, to the suction side of the compression (marked "suction" on top of the compressor), and the high-pressure gauge hose, the red one, to the discharge side (marked "disch"). The middle white hose is connected to the suction side of the vacuum pump (Fig. 8-97).

NOTE: The packings in the nipples must only be tightened with the fingers when they are connected in order not to damage them.

3. Start the vacuum pump and then open both the valves at the pressure gauges slowly and simultaneously.

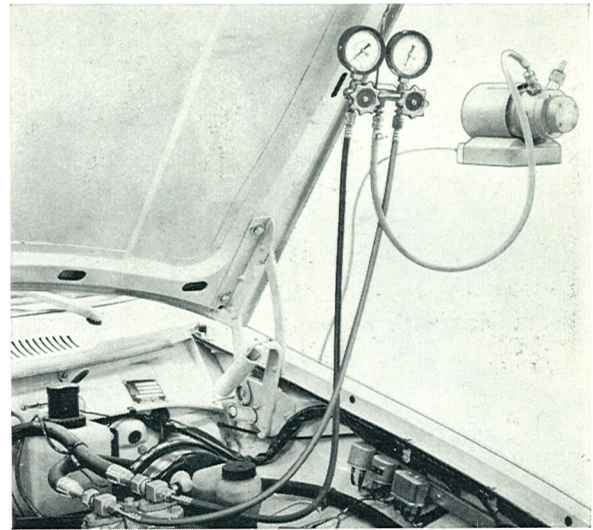

Fig. 8-97. Connecting vacuum pump

VOLVO
107290

NOTE: With all pressures balancing in the system, the valves should be opened very slowly otherwise there is risk of the compressor oil being sucked out.

4. Let the vacuum pump run until the low-pressure gauge indicates a vacuum of about 28" below atmospheric pressure. This vacuum is generally obtained quite quickly, but in order to be sure that all moisture has been removed from the system, the pump should be driven for at least 60 minutes at a temperature of below 30°C (86°F) and at least for 30 minutes at temperatures above 30°C (86°F). Thereafter close the pressure gauge valves and stop the pump.
5. If a vacuum of 28" does not arise or if it drops a lot after the valves have been closed, there must be a leak in the system, which is easy to trace. After correcting the leak, repeat points 3 and 4.

LEAK TEST

1. Disconnect the white hose from the vacuum pump and connect it to the refrigerant can (Fig. 8-98).

NOTE: Under no circumstances whatsoever may the refrigerant can be placed on its side or inverted. It must always be upright while the system is being filled, otherwise fluid will be sucked into the compressor and damage it.

2. Open the valve on the refrigerant can and both the valves at the pressure gauges.
3. When the whistling sound ceases, there is pressure balance in the system, and about 1 hg (3 1/2 oz) refrigerant left in it. By letting all the valves remain open, this situation will remain even if there is a leak in the system.

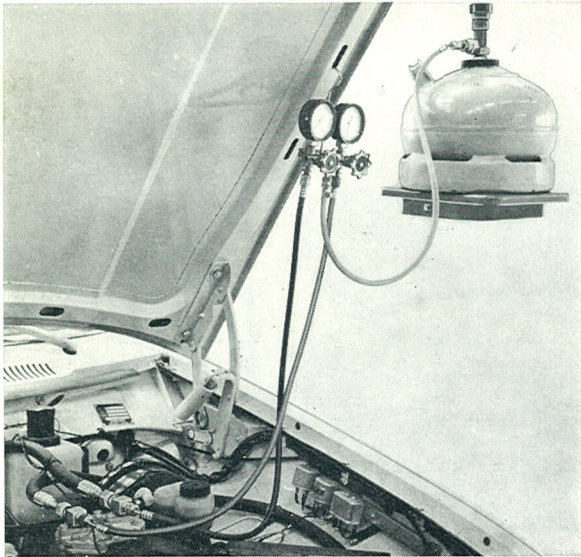

Fig. 8-98. Connecting refrigerant can

4. Light the leak detector and check the entire system at all the connections by holding the end of the hose next to the connection (Fig. 8-99). If there is leak, the color of the flame will change to blue-green.

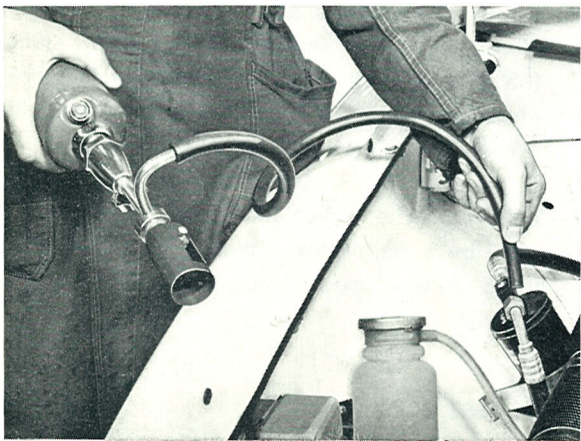

Fig. 8-99. Leakage test

Check the entire system even if leaks are discovered at an early stage.

NOTE: in all cases where gas might escape, the hands and bare skin should be protected with rubber gloves, etc.

5. If a leak is discovered, seal it and then test the system again.

FILLING

1. Shut off the valves on the refrigerant can and the pressure gauges.
2. Disconnect the hose from the refrigerant can and insert it in an exhaust suction hose. Slowly open the valves at the pressure gauges and release the gas in the system. By releasing this amount (1 hg=3.3 oz.) refrigerant, the air in the system accompanies it and this results in an effective drying of the system. Moisture is bad for the air conditioning system since it can easily freeze and plug the TEV valve at the evaporator unit.
3. When the pressure gauges indicate zero, close the valves on the gauges. Connect the white hose to the vacuum pump. Start the pump and open the valves slowly. Allow the pump to go for about two minutes after the low-pressure gauge has shown 28" below atmospheric. Then close the valves and stop the pump.
4. Disconnect the hose from the vacuum pump and connect it to the refrigerant can.
5. Place the can on a balance and read the weight with the hose connected.
6. Open the valves on the refrigerant can and both the pressure gauges. When the whistling sound ceases, close the valve on the high-pressure gauge.

NOTE: This valve must not be opened while the work is in progress.

7. Connect the tachometer and the exhaust hose. Start the engine and run it at about 33 r/s (2000 rpm). Set the cooling control to maximum cooling and the blower to maximum speed. Open the car doors and let them stay open otherwise the vehicle will cool down internally and this will cause the solenoid coupling on the compressor to cut out.
8. When the balance shows 8 hg (28 oz) less than at the reading in point 5, and the bubbling in the receiver-drier sightglass stops, lower the engine speed to idling and close the low-pressure gauge valve. If no bubbles are observed in the sightglass at idling, then the filling is completed. If there are still bubbles in the sightglass proceed as follows: Open the low-pressure gauge valve, raise the engine speed and add a further .5 hg (2 oz) refrigerant.
9. Close the valves on the low-pressure gauge and the refrigerant can. Stop the engine. Disconnect the hoses and screw tight the compressor cap nuts.

GROUP 86

BUMPERS

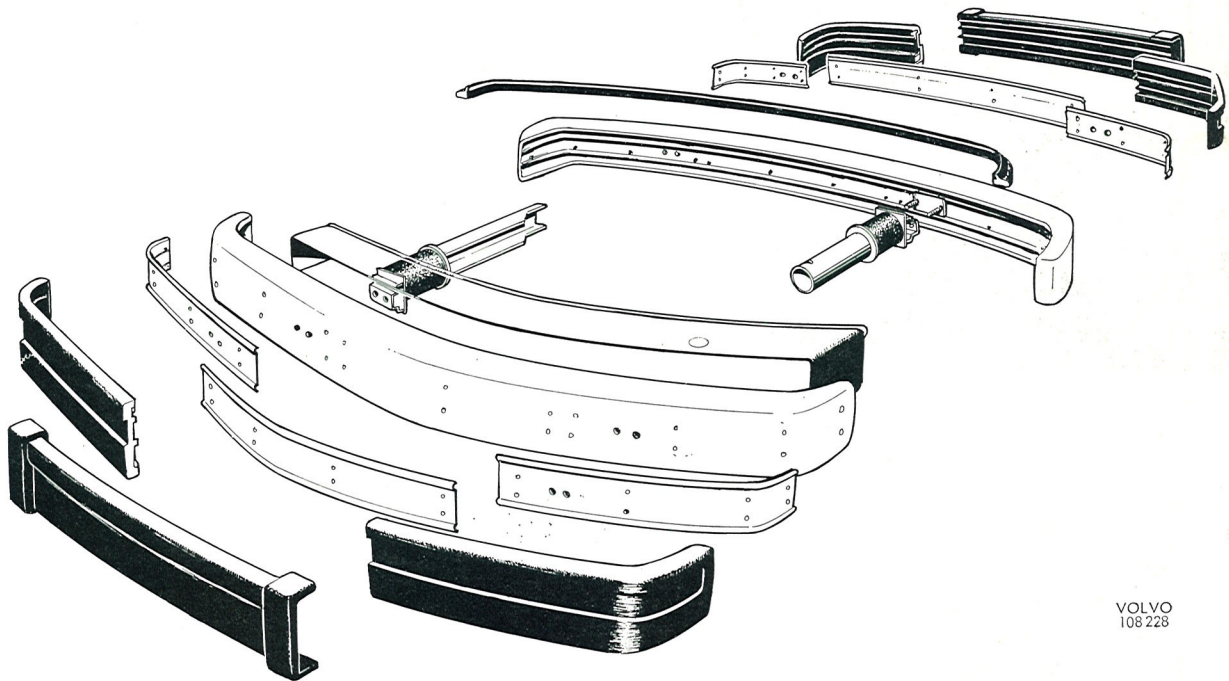

VOLVO
108 228

Fig. 8-100. Bumper, except USA

The bumpers, Fig. 8-100, are made in aluminum and provided with heavy, energy absorbing rubber strips. Hydraulic dampers retain the bumpers on cars intended for the USA market. This bumper can stand a barrier test of 8 km=5 mph, front and rear. The bumpers on vehicles intended for other markets are retained by rubber hole springs, see Fig. 8-102. These bumpers protect for damages at speeds below 4.5 km/h.

Volvo Standard Times:	Op. No.
FRONT BUMPER BAR or rubber moulding, replace, excl. support brackets	86130
REAR BUMPER BAR, d:o	86132
FRONT BUMPER ENERGY ABSORBER, replace, each	86206
REAR BUMPER ENERGY ABSORBER, replace each	86208

REMOVING AND INSTALLING FRONT BUMPER, USA

The front bumper is removed in the following way: First take off the rubber cover washers which are in the cover strip above the bumper. Then undo the nuts (2, Fig. 101) and pull out the bolts (1). This releases the bumper fully. Installation is in reverse order to removal.

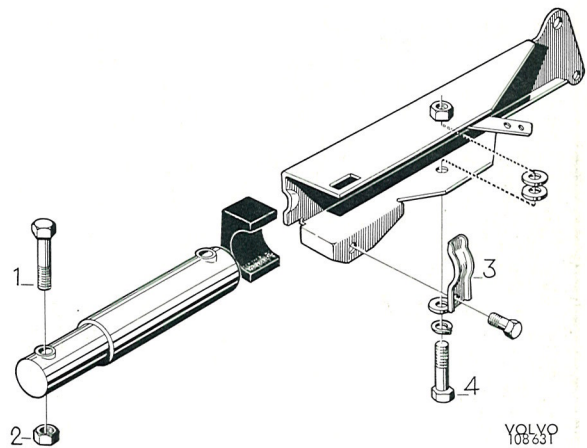

VOLVO
108 337

Fig. 8-101. Bumper attachment, USA

REMOVING AND INSTALLING REAR BUMPER WITH HYDRAULIC DAMPERS

1. Open the trunk lid and unfold the floor mat.
2. Remove, on the trunk floor, the bolts retaining the front of the hydraulic dampers to the side members of the vehicle.
3. Remove, from the underside, the bolts retaining the rear of the hydraulic dampers to the rear lower panel.
4. Lift out the bumper unit, complete with hydraulic dampers.
5. Installation is in reverse order to removal.

REPLACING RUBBER COVER, BETWEEN BUMPER AND REAR LOWER PANEL

1. Pull out, sideways, the moulding complete with rubber cover from the rear lower panel.
2. Disengage the rubber cover from the moulding.
3. Fold the new rubber cover over the moulding.
4. Press the unit (moulding and rubber cover) on the rear lower panel and check that the clips snap in place.

REPLACING REAR BUMPER FACE RUBBER MOULDINGS

1. Remove the bolts retaining the bumper to the hydraulic damper.
2. Lift out the bumper.
3. Remove the bars, retaining the rubber mouldings, from the bumper bar.
4. Disengage the rubber mouldings from the bars.
5. Install the new rubber mouldings by folding them over the retaining bars.
3. Install the units (retaining bars and rubber mouldings) to the bumper bar.
Use a small screwdriver to find the bolt holes.
7. Attach the bumper bar to the hydraulic dampers.

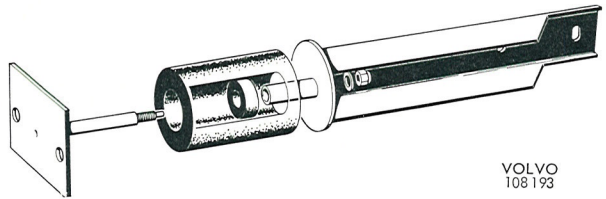

8-102. Bumper attachment, except USA

VOLVO
108 193

REPLACING FRONT BUMPER SHOCK ABSORBERS

Volvo Standard Times Op. No 86206

The shock absorber is removed by taking off the clamps (3) and the bolts (4). When the bumper with shock absorber is fully loose, they are removed as a single unit. Thereafter undo the bolting (1 and 2) and replace the shock absorber with a new one by first bolting it to the bumper, without tightening up. Then install the bumpers to their rear anchorages. Install the bolt (4) with spring washer, then the spacer washers (one on each side of the shock absorber) and the nut without tightening the nut. Now install the clamp (3). Use polygrip pliers. Thereafter tighten up bolts and nuts.

The rear bumper shock absorbers are removed by releasing the front or rear attachment for the bumper shock absorbers.