

COOLING SYSTEM

DESCRIPTION

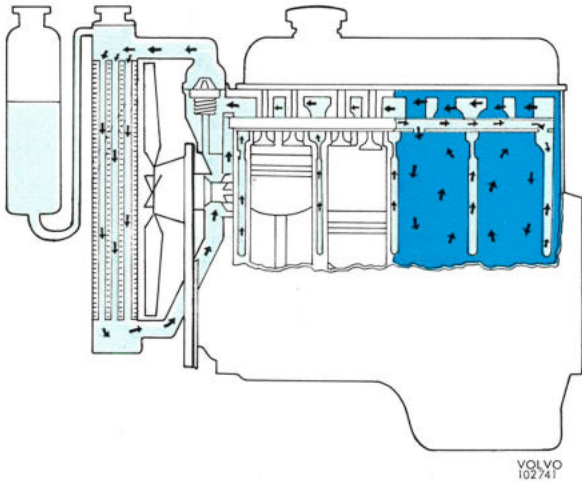

Fig. 2-123. Sealing cooling system

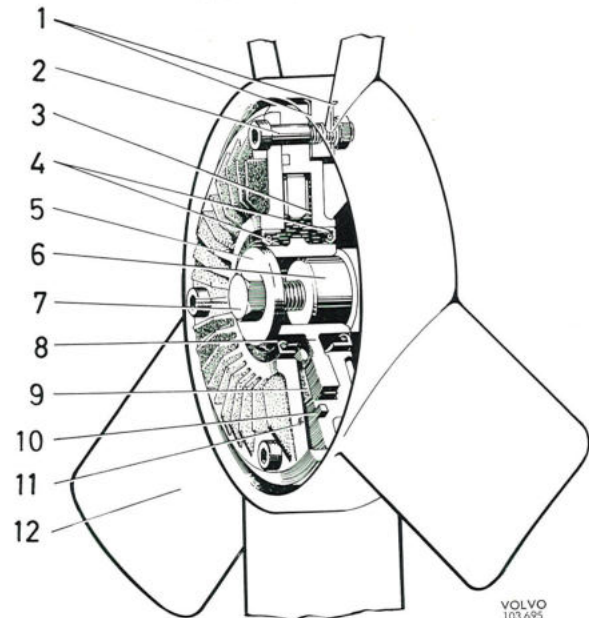

Fig. 2-124. Viscous fan

1. Washers
2. Bolt
3. Oil
4. Seals
5. Washer
6. Flange, water pump
7. Center bolt
8. Hub
9. Friction material
10. Rubber ring
11. Casing
12. Fan blade

GENERAL

The engine is water-cooled and the cooling system is of the sealed type, see Fig. 2-123. The B 20 A engine is fitted with a fixed fan. A speed-regulated fan, a so-called viscous type (see Fig. 2-124), is fitted on the B 20 B unit. Its function is to ensure that the fan blades do not exceed a certain speed even if the engine speed is exceeded. See Fig. 2-130. The five fan blades are mounted asymmetrically to keep down the noise level. The fan coupling consists of the casing (11, Fig. 2-124) in which the plastic fan blades (12) are secured with the bolt (2). The casing (11) has two halves which, however, cannot be separated for repairs, the fan coupling then being replaced complete. The hub (8) has a light fit on the water pump flange (6) and is locked by means of the center bolt (7). The hub is provided with a slip disc of friction material (9) surrounded by oil. During idling and at low speeds, the

slipping is insignificant, so that the fan provides an air current for good cooling. When the ingoing speed (that of the water pump) exceeds about 2600 r.p.m., the slipping increases (see Fig. 2-130). With this arrangement, the fan speed should never exceed about 3000—3500 r.p.m. The fan noise output would then be low compared with a fan which runs at the same high speeds as the water pump. Compared with this latter type of fan, the output loss will be less for the viscous type fan.

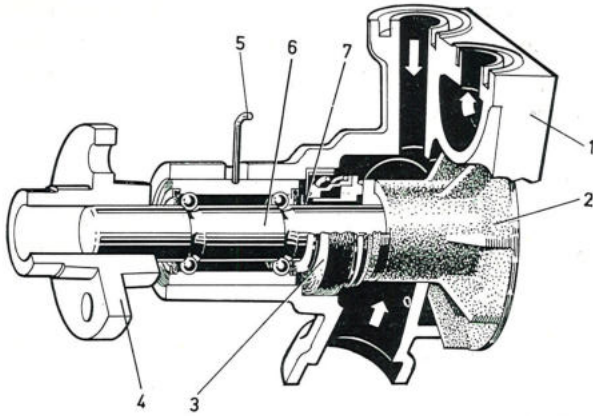

Fig. 2-125. Water pump

- | | |
|--------------|--|
| 1. Housing | 5. Lock spring |
| 2. Impeller | 6. Shaft with ball bearings
(integral unit) |
| 3. Seal ring | |
| 4. Flange | 7. Wear ring |

YOLVO
103307

A centrifugal pump, Fig. 2-125, takes care of the coolant circulation and a twin operating thermostat provides rapid warming up of the engine and contributes to the engine maintaining the most suitable temperature under all operating conditions.

The cooling system has a capacity of 8.6 litres (18 pints). Of this quantity, 0.6 litre (1¼ pints) fills the expansion tank at maximum level.

In order to achieve the desired effect with the sealed cooling system, it must be well filled and not leak. As coolant, a mixture consisting of 50 % ethylene glycol and 50 % water is used all year round. This mixture provides protection against frost down to minus 35° C (minus 32° F) and should be changed every other year, on which occasion the engine, radiator and expansion tank should be flushed with clean water.

COOLING SYSTEM INNER CIRCUIT (BY-PASS)

The cooling system consists of two circuits, an inner and an outer one. When the engine is warming up and in very cold weather when large quantities of heat are required for warming up the inside of the car, the coolant circulates almost exclusively through the inner circuit (the by-pass). This circuit covers the engine and car heater. The thermostat is closed, that is, the outlet to the radiator is shut off. The coolant passes through the thermostat by-pass to the distribut-

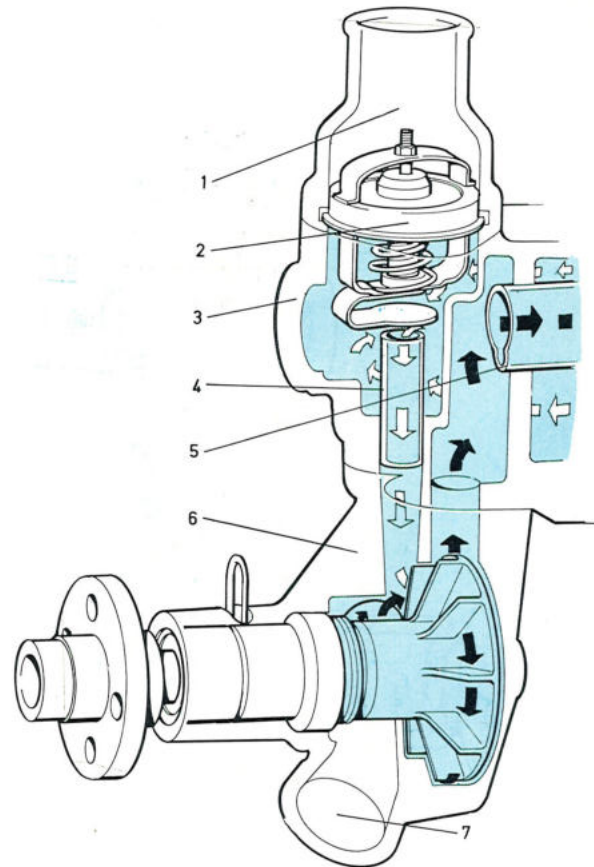

Fig. 126. Coolant flow, thermostat closed

- | | |
|------------------|---------------------|
| 1. To radiator | 5. Distributor pipe |
| 2. Thermostat | 6. Water pump |
| 3. Cylinder head | 7. From radiator |
| 4. By-pass pipe | |

YOLVO
103308

or pipe (5, Fig. 2-126) in the cylinder head. This results in a uniform cooling of the warmest parts in the cylinder head. Even the parts around the spark plugs are also cold and thereby maintained at a constant temperature. The coolant surrounding the cylinder walls is circulated by means of thermo-syphon action.

COOLANT SYSTEM OUTER CIRCUIT

When the coolant in the inner circuit reaches a suitable temperature for the engine, the thermostat begins to open, during which time the by-pass between the thermostat housing and the pump gradually closes, see Fig. 2-127.

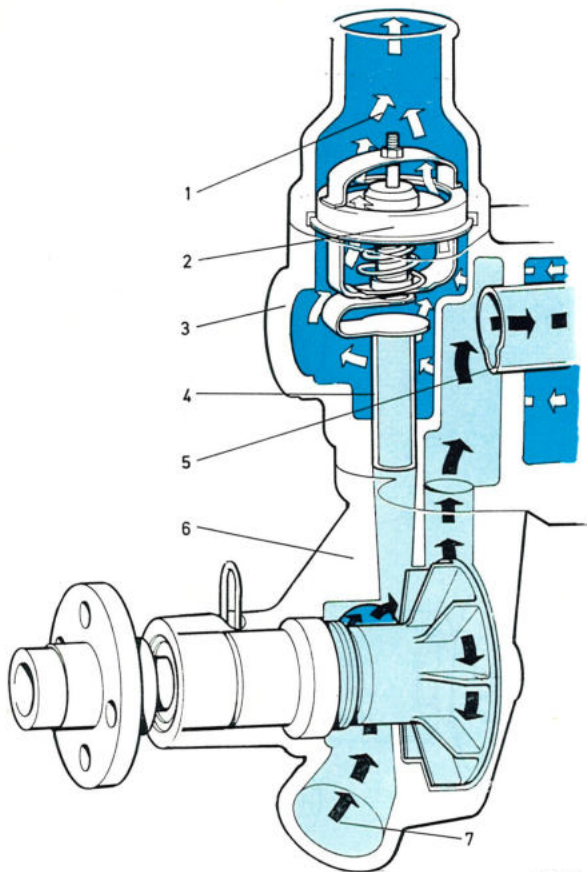

Fig. 2-127. Coolant flow, thermostat open
Concerning numbers above, see previous figure

Coolant flows from the engine into the upper part of the radiator, is cooled and then sucked by the pump out from the lower part of the radiator from where it is conveyed into the engine through the distributing pipe.

An air cushion forms in the upper part of the expansion tank and permits the coolant to expand without involving any loss of coolant so that there is air suction at reduced temperature and volume. This arrangement ensures that the cooling system is always filled with coolant, thus minimizing the risk of corrosion. When the cooling system is being topped up, it will probably be difficult to prevent air from entering this system. The air, however, is subsequently separated and forced out into the expansion tank where it is replaced by coolant from this tank. It is, therefore, important to check the coolant level after the system has been emptied and filled with new coolant.

The expansion tank cap is provided with a valve which opens when the pressure in the system goes up to 0.7 atmospheric gauge. There is also a valve which opens when there is a partial vacuum in the system and admits air into the expansion tank.

REPAIR INSTRUCTIONS

RADIATOR

TOPPING UP WITH COOLANT

Topping up with coolant, consisting of 50 % ethylene glycol and 50 % water (all year round) is done in the expansion tank, when the level has fallen to the "Min" mark.

N.B. Never top up with water only.

DRAINING THE COOLING SYSTEM

To drain the cooling system, open a cock on the engine and remove the lower radiator hose. The expansion tank is emptied by first taking it off its mounting and holding it at a sufficient height that the coolant runs into the radiator. Another way to empty the tank is by turning it upside down.

FILLING EMPTY SYSTEM WITH COOLANT

Before filling, flush the cooling system with clean water. When filling with coolant, through the filler opening on top of the radiator, the heater control should be set at max. heat. Fill the radiator to the top and fit the cap. Fill also the expansion tank to the "Max" mark or to max. 30 mm (1/8") above this mark. Run the engine for several minutes at different speeds. If necessary, top up with more coolant and then fit the expansion tank cap. After driving for a short time, check the coolant level and top up with more coolant since it takes some time before the system is completely devoid of air.

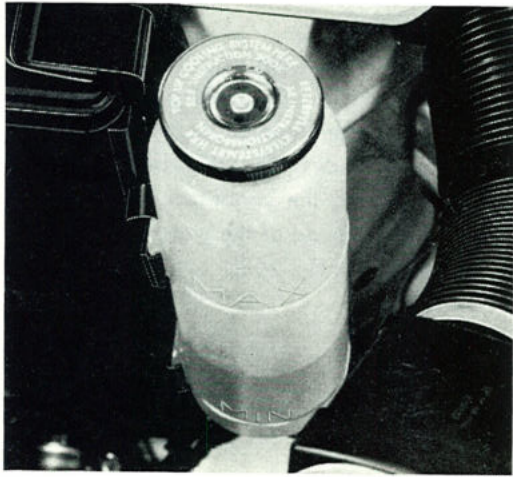

Fig. 2-128. Expansion tank

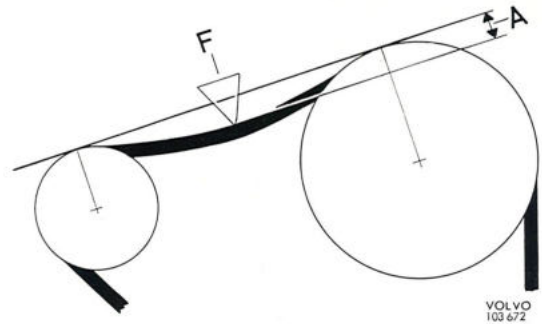

Fig. 2-129. Fan belt tension

F=5.6—7.6 kg (12—17 lb.) A=10 mm (approx. 3/8")

COOLING SYSTEM LEAKAGE CHECK

The cooling system is checked for leakage as follows: Remove the expansion tank cap and make sure that the filling hole and sealing surface are clean. Connect a cooling system pressure tester to the filling hole according to the instructions of the manufacturer. Make sure that the rubber bush (if one is fitted) faces correctly. Carefully pump up the pressure to 0.7 kg/cm² (10 lb/sq.in.). Observe the pressure tester gauge. The pressure must not drop noticeably during 30 seconds. If it does, examine and remedy the leakage.

REPLACING THE RADIATOR

1. Remove the radiator cap and drain the system of coolant by disconnecting the lower radiator hose.
2. Remove the expansion tank with hose and empty out the coolant. Remove the upper radiator hose.
3. Remove the bolts for the radiator and fan casing. Lift off the radiator.
4. Place the radiator in position and tighten the bolts for the radiator.
5. Fit the radiator hoses as well as the expansion tank with hose.
6. Fill with coolant, see under "Filling empty system with coolant". Start the engine and check for leakage.

REPLACING THE WATER PUMP

Remove the radiator according to the instructions given under "Replacing the radiator" and screw off

the water pump. Clean the sealing surfaces and refit the pump with new gasket. Make sure when fitting that the sealing rings on the upper side of the pump locate correctly. Also press the pump upwards against the cylinder head extension under the bolting, so that the sealing between the pump and cylinder head will be satisfactory. Make sure that the sealing rings at the water pipes are not damaged and press in the pipes thoroughly when attaching. Note that the sealing rings for the B 20 A engine are thicker (9.5 mm = 0.4") then those for the B 20 B unit (8.5 mm = 0.3"). The dimensions apply to new rings.

THERMOSTAT

After being removed, the thermostat can be tested in a vessel containing heated water. The thermostat should open and close according to the values given in "Specifications". A faulty thermostat should be discarded. Use a new gasket when fitting the thermostat.

TENSIONING THE PULLEY BELT

The pulley belt is tensioned so that it can be deflected 10 mm (approx. 3/8") with a force of 5.6—7.6 kg (12—17 lb.) applied to the belt in the middle between the water pump pulley and alternator pulley.

N.B. The alternator must not be obliquely loaded. If an iron lever is used for adjusting, it should be placed between the engine and the **front alternator end**.

Note that if the lower alternator bolt is not slackened during adjustment, there will be heavy stresses on the drive end bearing shield.

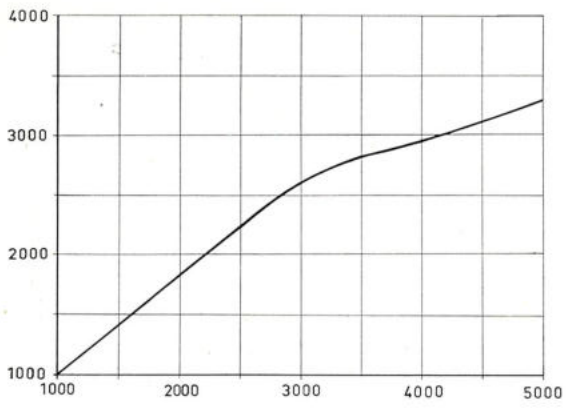

Fig. 2-130. Curve for fan coupling slip

VOLVO
103 258

FAN COUPLING

The fan coupling function can be checked with a stroboscope with variable blinking frequency. Make a mark on the fan and one on the water pump pulley. Find out the speed relationship between fan and pulley by means of the stroboscope. The fan speed should follow the speed of the water pump according to the curve given in Fig. 2-130.

- | | |
|--|-----------------------------|
| 1. Cold-air hose | 44. Reinforcing bracket |
| 2. Warm-air hose | 45. Bush |
| 3. Flap, constant air temperature device | 46. Seal |
| 4. Fuel line | 47. Oil pump |
| 5. Thermostat | 48. Main bearing cap |
| 6. Valve tappet | 49. Delivery pipe |
| 7. Valve spring | 50. Main bearing shell |
| 8. Washer | 51. Crankshaft |
| 9. Valve collet | 52. Sump |
| 10. Exhaust valve | 53. Piston rings |
| 11. Connection for crankcase hose | 54. Connecting rod cap |
| 12. Valve tappet seal | 55. Connecting rod |
| 13. Intake valve | 56. Camshaft |
| 14. Oil filler cap | 57. Piston |
| 15. Carburettor | 58. Bush |
| 16. Damping device | 59. Big-end bearing shell |
| 17. Air cleaner | 60. Gudgeon pin |
| 18. Hose for crankcase gases | 61. Washer |
| 19. Vacuum hose for distributor | 62. Spacing ring |
| 20. Choke wire | 63. Camshaft gear |
| 21. Rocker arm | 64. Nut |
| 22. Rocker arm shaft | 65. Crankshaft gear |
| 23. Spring | 66. Hub |
| 24. Push rod | 67. Washer |
| 25. Bearing bracket | 68. Bolt |
| 26. Rocker arm casing | 69. Pulley |
| 27. Rubber seal | 70. Key |
| 28. Cable terminal | 71. Seal |
| 29. Rubber seal | 72. Fan |
| 30. Cylinder head | 73. Oil nozzle |
| 31. Vacuum hose | 74. Key |
| 32. Vacuum governor | 75. Timing gear cover |
| 33. Distributor | 76. Coolant inlet |
| 34. Condenser | 77. Gasket |
| 35. Valve tappet | 78. Water pump |
| 36. Retainer | 79. Gasket |
| 37. Flywheel casing | 80. Pulley |
| 38. Cylinder block | 81. Alternator |
| 39. Gear wheel | 82. Sealing ring |
| 40. Pilot bearing | 83. Cylinder head gasket |
| 41. Flywheel | 84. Tensioner |
| 42. Flange bearing shell | 85. Water distributing pipe |
| 43. Sealing flange | 86. Thermostat |
| | 87. Coolant outlet |

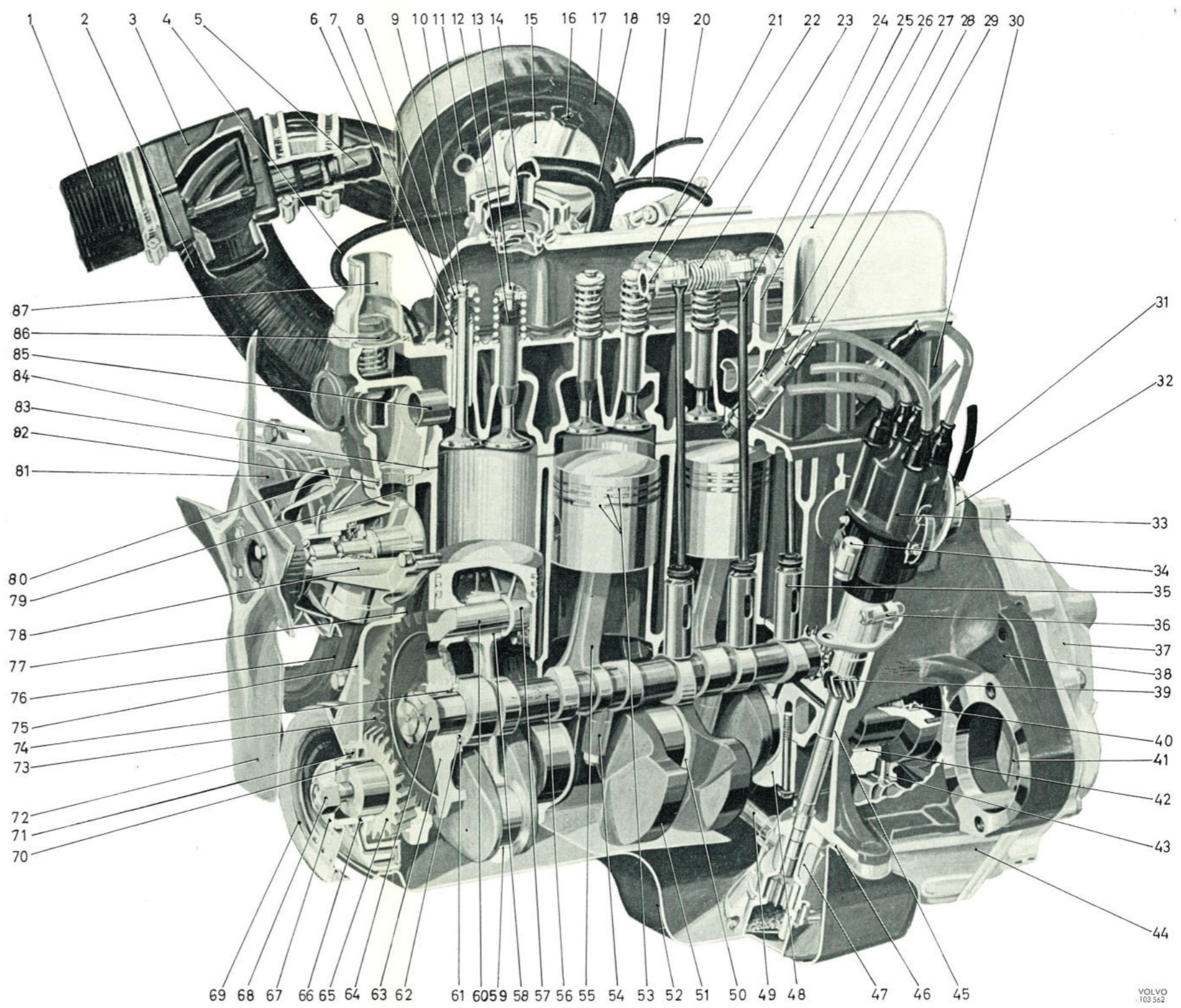

Illustration 2-A. B 20 A engine

- | | |
|---|-----------------------------|
| 1. Cold-air inlet | 45. Flywheel |
| 2. Warm-air inlet | 46. Flange bearing shell |
| 3. Flap, constant air temperature device | 47. Sealing flange |
| 4. Thermostat | 48. Reinforcing bracket |
| 5. Air cleaner insert | 49. Gasket |
| 6. Air cleaner | 50. Sump |
| 7. Choke wire | 51. Oil pump |
| 8. Valve guide | 52. Main bearing cap |
| 9. Valve spring | 53. Crankshaft |
| 10. Washer | 54. Piston rings |
| 11. Valve collet | 55. Connecting rod |
| 12. Exhaust valve | 56. Connecting rod cap |
| 13. Carburettor | 57. Camshaft |
| 14. Damping device | 58. Piston |
| 15. Hose connection for crankcase | 59. Connecting rod bush |
| 16. Valve guide seal | 60. Big-end bearing shell |
| 17. Hose for floatchamber ventilation | 61. Gudgeon pin |
| 18. Intake valve | 62. Washer |
| 19. Fuel hose | 63. Spacing ring |
| 20. Hose connection for brake servo | 64. Camshaft gear |
| 21. Air cleaner hose for floatchamber ventilation | 65. Key |
| 22. Clamp | 66. Nut |
| 23. Hose for crankcase gases | 67. Crankshaft gear |
| 24. Choke wire | 68. Hub |
| 25. Rocker arm | 69. Washer |
| 26. Rocker arm shaft | 70. Bolt |
| 27. Spring | 71. Pulley |
| 28. Thrust rod | 72. Key |
| 29. Bearing bracket | 73. Seal |
| 30. Rubber seal | 74. Oil nozzle |
| 31. Cable terminal | 75. Timing gear casing |
| 32. Rubber seal | 76. Coolant inlet |
| 33. Rocker arm casing | 77. Gasket |
| 34. Cylinder head | 78. Water pump |
| 35. Vacuum hose | 79. Fan blade |
| 36. Distributor | 80. Fan coupling |
| 37. Vacuum governor | 81. Gasket |
| 38. Flywheel casing | 82. Sealing ring |
| 39. Condenser | 83. Pulley |
| 40. Retainer | 84. Cylinder head gasket |
| 41. Valve tappet | 85. Alternator |
| 42. Cylinder block | 86. Tensioner |
| 43. Gear wheel | 87. Water distributing pipe |
| 44. Pilot bearing | 88. Thermostat |
| | 89. Coolant outlet |

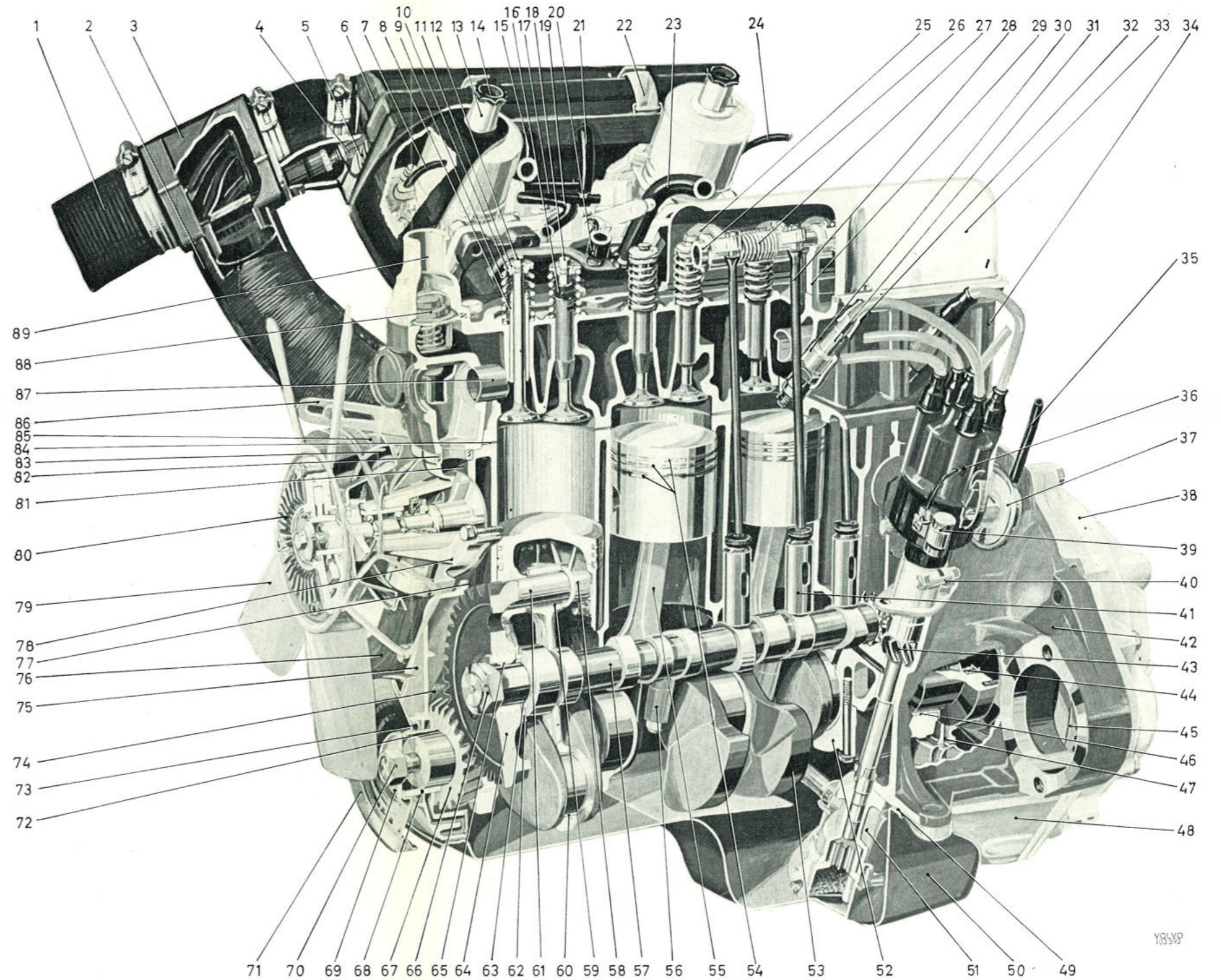

Illustration 2-B. B 20 B engine (with SU-carburetors)