

CONTENTS

Specifications	1
Tools	8
Group 20. General	
Description	10
Repair Instructions	11
Removing the engine	11
Installing the engine	11
Replacing the sump	12
Group 21. Engine	
Description	14
Repair Instructions	16
Dismantling the engine	16
Assembling the engine	16
Valve grinding and decarbonizing	17
Cylinder head and valves	18
Cylinder block	21
Pistons, piston rings and gudgeon pins	21
Connecting rods	23
Crankshaft	24
Replacing oil seal, timing gear casing	26
Replacing the timing gear casing	27
Replacing the timing gears	27
Positive crankcase ventilation	28
Group 22. Lubricating System	
Description	30
Repair Instructions	31
Group 23. Fuel System	
Description	34
Repair Instructions	43
Carburettor, Zenith	43
Carburettor, Stromberg	45
Air cleaner	49
Fuel pump	51
Group 25. Cooling System	
Description	54
Repair Instructions	56
Fault Tracing	60

SPECIFICATIONS

GENERAL

Type designation	B 18 A type 1	B 18 A type 2
Output, b.h.p. at r.p.m. (SAE)	75/4500	85/5000
(DIN)	68/4500	75/4700
Max. torque, kgm (lb.ft.) at r.p.m. (SAE)	14.0 (101)/2800	15.0 (108)/3000
(DIN)	13.5 (98)/2600	14.5 (105)/2300
Compression pressure (warm engine) when turned over with starter motor, 250–300 r.p.m., kg/cm ²	11–13	11–13
lb/sq.in.	156–185	156–185
Compression ratio	8.5:1 (late prod. 8.7:1)	8.7:1
Number of cylinders	4	4
Bore	84.14 mm (3.312")	84.14 mm (3.312")
Stroke	80 mm (3.15")	80 mm (3.15")
Displacement	1.78 litres	1.78 litres
Weight, including electrical equipment and carburettor	approx. 155 kg (341 lb.)	approx. 155 kg (341 lb.)

CYLINDER BLOCK

Material	Special-alloy cast iron
Bore, standard	84.14 mm (3.312")
0.020" oversize	84.65 mm (3.333")
0.030" "	84.90 mm (3.342")
0.040" "	85.16 mm (3.353")
0.050" "	85.41 mm (3.362")

PISTONS

Material	Light-alloy
Weight	425 ± 5 g (14.9 ± 0.18 oz.)
Permissible weight difference between pistons in same engine	10 grammes (0.35 oz.)
Height, overall	83.5 mm (3.29")
Height from centre of gudgeon pin to piston crown	46 mm (1.81")
Piston clearance	0.02–0.04" (0.0008–0.0016")

PISTON RINGS

Piston ring gap measured in ring opening	0.025–0.50 mm (0.010–0.020")
Piston ring oversizes	0.020" 0.040"
	0.030" 0.050"

Compression rings

Marked "TOP". Upper ring on each piston chromed.

Number of rings on each piston	2
Height	1.98 mm (0.078")
Piston ring clearance in groove	0.054–0.081 mm (0.0021–0.0032")

Oil scraper rings

Number on each piston	1
Height	4.74 mm (0.186")
Piston ring clearance in groove	0.044–0.072 mm (0.0017–0.0028")

GUDGEON PINS

Floating fit. Circlips at both ends in piston.

Fit:	
In connecting rod	Close running fit
In piston	Push fit
Diameter, standard	22.00 mm (0.866")
0.05 mm (0.002") oversize	22.05 mm (0.868")
0.10 mm (0.004") "	22.10 mm (0.870")
0.20 mm (0.008") "	22.20 mm (0.874")

CYLINDER HEAD

Height, measured from cylinder head contact surface to bolt level	88 mm (3.64")
Distance from upper surface of cylinder head to upper end of over-flow pipe (pipe located under thermostat)	35 mm (1.38")

CRANKSHAFT

Crankshaft end float	0.017–0.108 mm (0.0007–0.0042")
Main bearings, radial clearance	0.020–0.077 mm (0.0010–0.0030")
Big-end bearings, radial clearance	0.039–0.081 mm (0.015–0.032")

MAIN BEARINGS

Main bearing journals

Diameter, standard	63.441–63.454 mm (2.4977–2.4982")
undersize 0.010"	63.187–63.200 mm (2.4877–2.4882")
0.020"	62.933–62.946 mm (2.4777–2.4782")
0.030"	62.679–62.692 mm (2.4677–2.4682")
0.040"	62.425–62.438 mm (2.4577–2.4582")
0.050"	62.171–62.184 mm (2.4477–2.4482")

Width on crankshaft for flange bearing shell

Standard	38.930–38.970 mm (1.5327–1.5342")
Oversize 1 (undersize shell 0.010")	39.031–39.072 mm (1.5367–1.5383")
2 (" " 0.020")	39.133–39.173 mm (1.5407–1.5422")
3 (" " 0.030")	39.235–39.275 mm (1.5447–1.5463")
4 (" " 0.040")	39.336–39.376 mm (1.5487–1.5502")
5 (" " 0.050")	39.438–39.478 mm (1.5527–1.5543")

Main bearing shells

Thickness, standard	1.985–1.991 mm (0.0781–0.0784")
undersize 0.010"	2.112–2.118 mm (0.0831–0.0834")
0.020"	2.239–2.245 mm (0.0881–0.0884")
0.030"	2.366–2.372 mm (0.0931–0.0934")
0.040"	2.493–2.499 mm (0.0981–0.0984")
0.050"	2.620–2.626 mm (0.1031–0.1034")

BIG-END BEARINGS

Big-end bearing journals

Bearing seat width	31.950–32.050 mm (1.2579–1.2618")
--------------------------	-----------------------------------

Diameter, standard	54.080—54.102 mm (2.1295—2.1300")
undersize 0.010"	53.835—53.848 mm (2.1195—2.1200")
0.020"	53.581—53.594 mm (2.1095—1.1100")
0.030"	53.327—53.340 mm (2.0995—2.1000")
0.040"	53.073—53.086 mm (2.0895—2.0900")
0.050"	52.819—52.832 mm (2.0795—2.0800")

Big-end bearing shells

Thickness, standard	1.833—1.841 mm (0.0722—0.0725")
undersize 0.010"	1.960—1.968 mm (0.0772—0.0755")
0.020"	2.087—2.095 mm (0.0822—0.0825")
0.030"	2.214—2.222 mm (0.0872—0.0875")
0.040"	2.341—2.349 mm (0.0922—0.0925")
0.050"	2.468—2.476 mm (0.0972—0.0975")

CONNECTING RODS

End float on crankshaft	0.15—0.35 mm (0.006—0.014")
Length, centre—centre	145±0.1 mm (5.710±0.004")
Maximum permissible difference in weight between connecting rods in same engine	6 grammes (0.21 oz.)

FLYWHEEL

Permissible run-out, max.	0.05 mm/150 mm diam. (0.002"/6" diam.)
Ring gear (chamfer facing forwards)	142 teeth

FLYWHEEL HOUSING

Permissible axial throw, max.	0.05 mm/100 mm diam. (0.002"/4" diam.)
Max. radial throw for rear guide	0.15 mm (0.006")

CAMSHAFT

Marked	A
Number of bearings	3
Front bearing journal, diameter	46.975—47.000 mm (1.8494—1.8504")
Centre bearing journal, diameter	42.975—43.000 mm (1.6919—1.6929")
Rear bearing journal, diameter	36.975—37.000 mm (1.4557—1.4567")
Radial clearance	0.020—0.075 mm (0.0008—0.0030")
End float	0.020—0.060 mm (0.0008—0.0024")
Valve clearance for check of camshaft setting (cold engine)	1.1 mm (0.043")
Inlet valve should then open at	10° after T.D.C.

CAMSHAFT BEARINGS

Front bearing, diameter	47.020—47.050 mm (1.8512—1.8524")
Centre bearing, diameter	43.025—43.050 mm (1.6939—1.6949")
Rear bearing, diameter	37.020—37.045 mm (1.4575—1.4585")

TIMING GEARS

Crankshaft gear, number of teeth	21
Camshaft gear, (fibre), number of teeth	42

Lubricating oil filter

Type	Full-flow
Make	Wix or Mann

Lubricating oil pump

Oil pump, type	Gear pump
number of teeth on each gear	10
end float	0.02—0.10 mm (0.0008—0.0040")
radial clearance	0.08—0.14 mm (0.0032—0.0055")
tooth flank clearance	0.15—0.35 mm (0.0060—0.0140")

Relief valve spring (in oil pump)

Length, unloaded	Early prod.	Late prod.
	approx. 31.0 mm (1.22")	approx. 32.5 mm (1.28")
loaded with 4.0±0.2 kg (8.8±0.44 lb.)	27.5 mm (1.08")	
9.5±0.3 kg (21.0±0.66 lb.)	22.5 mm (0.88")	
8.0±0.8 kg (17.6±1.76 lb.)		22.5 mm (0.89")

FUEL SYSTEM**Fuel pump**

Fuel pump, type I diaphragm pump	AC—UG
Fuel pump, type II diaphragm pump	Pierburg APG
Fuel pump, type III diaphragm pump	AC—YD
Fule pressure, measured at same height as pump	min. 0.11 kg/cm ² (1.5 lb/sq.in.)
	max. 0.25 kg/cm ² (3.5 lb/sq.in.)

Carburettor type 1

Type	Down-draught
Make and designation	Zenith 36 VN
Venturi	30
Main jet	117
Compension jet	115
Idling jet	70
Idling air jet	70
Air jet for partial acceleration	1.40
Acceleration jet	40
Acceleration pump stroke	Short
Float valve	1.75
Washer for float valve, thickness	1 mm (0.04")
Idling speed (warm engine)	500—700 r.p.m.

Carburettor type 2

Type	Horizontal
Make and designation	Zenith-Stromberg 175 CD-2S
Number	1
Size (air intake diameter)	44.5 mm (1 3/4")
Metering needle, designation	4 E
Idling speed	600—700 r.p.m.
Oil for damping cylinder	Oil for automatic transmissions "ATF" type A

IGNITION SYSTEM

Voltage	12 V
Order of firing	1-3-4-2
Ignition timing setting, 97 octane (Research Method) at 1500 r.p.m. engine speed (vacuum regulator disconnected). Accurate adjust- ment should not be attempted when the engine is stopped	21-23° before T.D.C.
Sparking plugs	Bosch W 175 T1 or corresponding
Sparking plug gap	0.7-0.8 mm (0.028-0.032")
tightening torque	3.8-4.5 kgm (28-32 lb.ft.)

COOLING SYSTEM

	Type 1	Type 2
Type	Pressure	Sealed system
Radiator cap valve opens at	0.23-0.30 kg/cm ² (3-4 lb./sq.in.)	
Capacity	approx. 8.5 litres (2 Imp. galls. = 2 1/4 US galls.)	
Fan belt, designation	HC 38 x 35"	
tension: the pulley should start slipping when the force applied is	8.0-11.0 kg (17.6-24.3 lb.) at a lever of 150 mm (6")	

Thermostat

Type	Fulton Sylphon 1-1700-D 3
Marking	170
Starts to open at	75-78° C (167-172° F)
Fully open at	89° C (192° F)

TIGHTENING TORQUES

	Kgm	Lb.ft.
Cylinder head	8.5-9.5	61-69
Main bearings	12-13	87-94
Big-end bearings	5.2-5.8	38-42
Flywheel	4.5-5.5	32-40
Sparking plugs	3.8-4.5	27-33
Camshaft nut	13-15	94-108
Crankshaft pulley bolts	7-8	50-58
Dynamo bolts (3/8"-16)	3.5-4	25-29
Oil filter nipple	4.5-5.5	32-40
Sump bolts	0.8-1.1	6-8

WEAR TOLERANCES**Cylinders**

To be rebored when wear reaches (if engine shows abnormal oil consumption)	0.25 mm (0.10")
---	-----------------

Crankshaft

Permissible out-of-round on main bearing journals, max.	0.05 mm (0.002")
Permissible out-of-round on big-end bearing journals, max.	0.07 mm (0.003")
Max. crankshaft end float	0.15 mm (0.006")

Valves

Permissible clearance between valve stems and valve guides	0.15 mm (0.006")
Valve stems, permissible wear, max.	0.02 mm (0.0008")

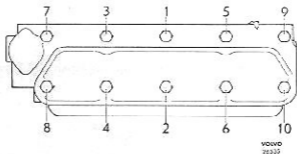

Tightening sequence for cylinder head bolts, B 18 engine

Camshaft

Permissible out-of-round (with new bearings), max.	0.07 mm (0.003")
Bearings, permissible wear	0.02 mm (0.0008")

Timing gears

Permissible backlash, max.	0.12 mm (0.005")
---------------------------------	------------------

TOOLS

The following special tools are required when carrying out repair and service work on the engine.

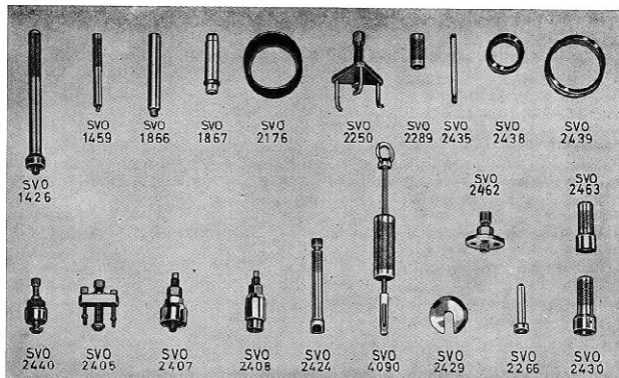

Fig. 1. Tools for engine and water pump

- | | | | |
|----------|--|----------|---|
| SVO 1426 | Tool for fitting pilot bearing. | SVO 2405 | Puller for crankshaft gear. |
| SVO 1459 | Tool for removing valve guides. | SVO 2407 | Press tool for fitting crankshaft gear. |
| SVO 1866 | Tool for removing and fitting gudgeon pins. | SVO 2408 | Press tool for fitting camshaft gear. |
| SVO 1867 | Tool for removing and fitting bush in rocker arm and connecting rod. | SVO 2424 | Grip tool for removing and fitting valve lappets. |
| SVO 2176 | Ring for fitting pistons (standard size). | SVO 4090 | Puller for pilot bearing. |
| SVO 2250 | Puller for camshaft gear. | SVO 2429 | Press tool for removing water pump impeller. |
| SVO 2289 | Tool for fitting valve guides. | SVO 2266 | Tool for removing and fitting hub and impeller in water pump. |
| SVO 2435 | Guide pins for fitting cylinderhead (2). | SVO 2430 | Tool for fitting seal in water pump. |
| SVO 2438 | Centring sleeve for timing gear casing and fitting felt ring circlip. | SVO 2462 | Puller for water pump hub. |
| SVO 2439 | Centring sleeve for rear sealing flange and fitting felt ring circlip. | SVO 2463 | Tool for fitting and removing water pump bearing. |
| SVO 2440 | Puller for crankshaft hub. | | |

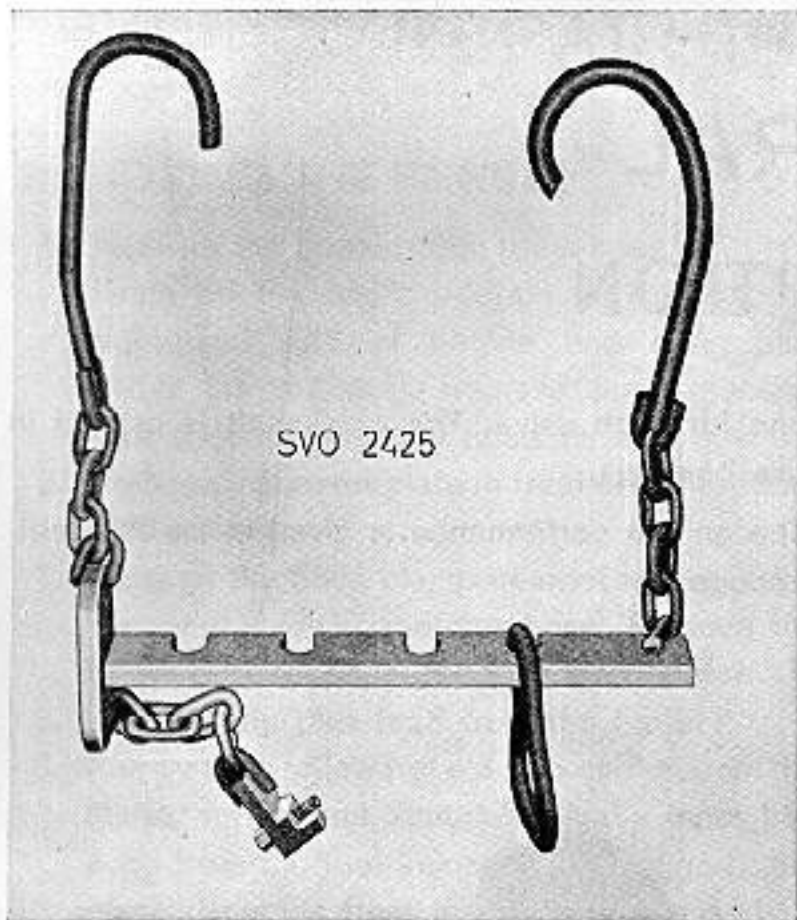

Fig. 2. Tool for removing engine

VOLVO
24842

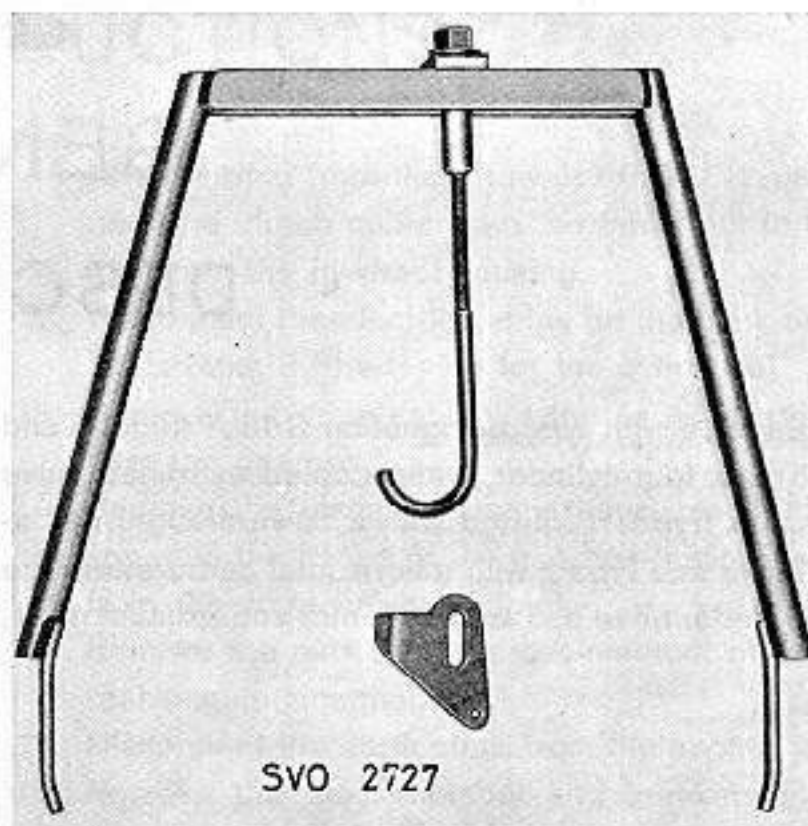

Fig. 3. Tool for removing oil sump, 140-series

VOLVO
2727

GRUPP 20

GENERAL DESCRIPTION

Engines with type designation B 18 A (Figs. 4 and 5) are four-cylinder, water-cooled overhead valve units. Type 1 is fitted with a down-draught carburettor and type 2 with a horizontal carburettor. The cylinder head has separate inlet and exhaust ports,

one for each valve. The crankshaft is carried in five bearings.

The engine performance is given in the "Specifications".

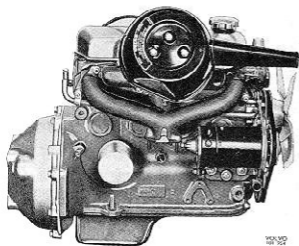

Fig. 4. B 18 A engine viewed from the right

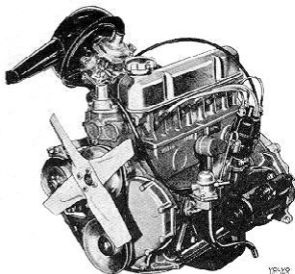

Fig. 5. B 18 A engine viewed from the left

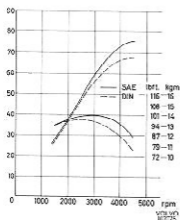

Fig. 6. Output-torque curves, type 1 engine

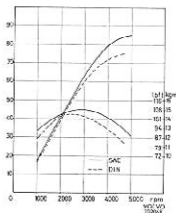

Fig. 7. Output-torque curves, type 2 engine

REPAIR INSTRUCTIONS

REMOVING THE ENGINE

1. Remove the bonnet from the hinges.
2. Drain off the coolant (drain the tap at rear right-hand side of engine and drain plug under the radiator). Remove the expansion tank together with the hose.
3. Remove the cover plate in front of the radiator (140-series).
4. Slacken the hose clamp nearest to the radiator for the lower radiator hose. Remove the upper radiator hose. Remove the radiator.
5. Remove the plus lead from the battery.
6. Remove the following: electric cables from the starter motor and ignition coil, the input fuel hose from the fuel pump (to be plugged), the electric cables from the temperature and oil pressure sending units and from the dynamo, the vacuum hose for the servo cylinder, the choke control, the heater hoses at the engine.
7. Remove the throttle control shaft from the pedal shaft, intermediate shaft and bracket.
8. Remove the nuts at the branch pipe flange of the exhaust manifold.
9. Place the gears in neutral. Remove the gear lever and put on a protective cover.
10. Jack up the vehicle with four blocks (for 140-series under the front jack attachments and in front of the rear jack attachment according to Fig. 8).
11. Place a jack under the gearbox. Remove the

return spring from the throw-out fork. Disconnect the clutch cable from the throw-out fork and from the flywheel housing.

12. Disconnect the electric cables for the back-up lights (and, if fitted, also for the overdrive).
13. Remove the drive cable for the speedometer from the gearbox.
14. Remove the clamp for the exhaust manifold.
15. Separate the flange of the gearbox (overdrive) from the front universal joint.
16. Remove the nuts for the cross-member of the rear engine mounting.
17. Disconnect the earth strap from the engine.
18. Remove the cross-member and brackets for the exhaust manifold and rear engine mounting.
19. Remove the lower nuts for the front engine mounting.
20. Fit on lifting tool SVO 2425 according to Fig. 9 and lift out the engine.

INSTALLING THE ENGINE

1. Fit on lifting tool SVO 2425 according to Fig. 9.
2. Lift in the engine. Place a jack under the gearbox and guide the engine into position. **N. B. Be careful not to damage the oil filter and oil pressure sending unit against the exhaust pipe.**

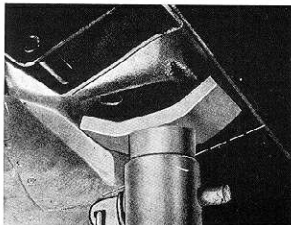

Fig. 8. Location of black stand, 140-series

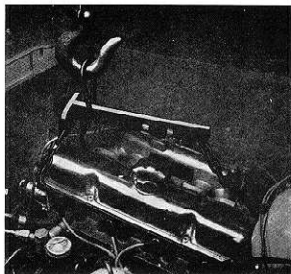

Fig. 9. Lifting out the engine

VOLVO
26492

- Tighten the nuts for the front engine mountings.
- Connect up the electric cables for the back-up lights (and overdrive).
- Fit the brackets for the exhaust manifold and rear engine mounting, the cross-member and the nuts for the rear engine mounting.
- Remove the jack and lifting tool SVO 2425.
- Tighten the flange of the exhaust pipe against the exhaust manifold.
- Fit the clamp for the exhaust pipe, the front universal joint to the flange (make sure the contact surfaces are clean), the drive cable of the speedometer, the earth cable, the clutch cable and return spring.
- Adjust the clutch play according to Part 4 (41).
- Remove the blocks from under the vehicle.
- Fit: heater hoses, electric cables to the temperature and oil pressure sending units, the throttle control shaft, the choke cable, the electric cables for the dynamo, starter motor and ignition coil.
- Fit the fuel hose and vacuum hose to the servo cylinder and battery cable.
- Fit the drain plug in the radiator, place the radiator in position and firmly secure it. Fit the cooling system hoses and expansion tank with hose, which is drawn from the radiator and in front of the expansion tank so that it does not come into contact with the fan.
- Fit the cover plate in front of the radiator. Fill the radiator with coolant and check the oil in the engine.
- Fit the bonnet. Fit the gear lever.

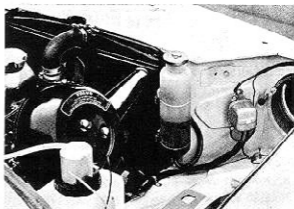

Fig. 10. Cooler and expansion tank

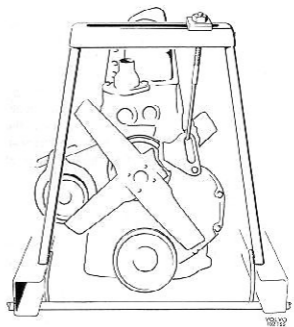

Fig. 11. Lifting tool SVO 2727

SUMP

Since it has been shown that, with regard to certain types of work on the engine, much time can be saved if the sump is removed without lifting out the engine, the following procedure has been adopted.

140-Series REMOVING

- Fit the plate of the lifting tool SVO 2727 at the upper bolt for the timing gear casing. Remove the washer.) Place the lifting tool and fix the hook in the plate according to Fig. 11. Raise the front end of the engine until there is no weight on the engine mountings. Remove the oil dipstick.

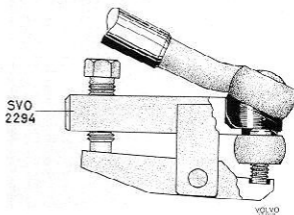

Fig. 12. Removing the steering rod

- Lift up the vehicle by placing blocks under the front jacking points. Drain off the engine oil.
- Remove the lower nuts for the engine mountings. Remove the steering rods from the pitman arm and relay arm with tool SVD 2294 according to Fig. 2-12.
- Place a jack under the front axle member. Remove the rear bolts on the front axle member and screw on instead two auxiliary screws (UNC 1/2-13x114). Remove the front bolts for the front axle member. Lower and remove the jack so that the front axle member is suspended in the two auxiliary bolts.
- Remove the plug for the oil temperature gauge and reinforcing bracket at the flywheel housing.
- Remove the bolts for the sump and lift off the sump.
- Remove the old gasket and clean the contact surfaces of the cylinder block and sump.

FITTING

- Place the sump and gasket in position and fit the bolts. (Note: for the four longest bolts should be at the edges of the sump.) Tighten well the drain plug as well as the plug for the oil temperature gauge.
- Place the reinforcing bracket in position and tighten all the bolts by hand. Then screw in firmly the bolts in the flywheel housing and then the bolts in the cylinder block.
- Raise the front axle member, tighten the front bolts. Remove the auxiliary bolts, fill and tighten the rear steering rods.
- Remove the blocks from the under the vehicle. Take off the lifting tool with plate. Fit the bolt (with washer) for the timing gear casing.
- Top up with oil and insert the oil dipstick.
- Start the engine and check for leakage.

P 120

REMOVING

- Lift up the vehicle about 30 cm (12") above the floor and place blocks under it near the jacking points.
- Apply a lifting device under the engine mountings. **N.B. Do not lift on the water pump.** Unscrew the nuts for the front engine mounting pads from below. Lift the engine as high as possible without pinching anything on the

scuttle and allow it to hang on pulley blocks, a workshop hoist, an engine lifter or similar.

- Place a jack under the front member. Slacken but do not remove the two bolts in the front member. Be careful not to lose any shims. Remove the four rear bolts and lower the front end as far as it will go.
- Remove the sump in the ordinary way.

FITTING

- Fit the sump.
- Thoroughly clean the front member and check that the shims are fitted correctly.
- Lift up the front end and tighten it down.

PV 544-210

REMOVING

- Lift up the vehicle about 30 cm (12") above the floor and place blocks under it near the jacking points.
- Apply a lifting device under the engine mountings. **N.B. Do not lift on the water pump.** Unscrew the nuts for the front engine mounting pads from below. Lift the engine as high as possible without pinching anything on the scuttle and allow it to hang on pulley blocks, a workshop hoist, an engine lifter or similar.
- Place a jack under the front member.
- Clean off around the brake pipe connections on the master cylinder. Disconnect the brake pipes to the front end on the master cylinder. Plug the lines in order to prevent impurities from entering the brake system.
- Remove the four front bolts for the front member. Screw in two bolts about 75 mm (2 15/16") long in place of these, one on each side. Remove the four rear bolts for the member.
- Lower the front end so that it is supported in the two long bolts.
- Remove the sump in the usual way.

FITTING

- Fit the sump.
- Thoroughly clean the front member and lift it up. Tighten the rear bolts. Remove the long bolts at the front and fit the ordinary ones.
- Clean off around the master cylinder and brake pipes. Fit the brake pipes.

GROUP 21

ENGINE

DESCRIPTION

CYLINDER BLOCK

The cylinder block (29, Illustration A) is made of special alloy cast iron and is cast in a single unit. The cylinder bores which are surrounded by cooling jackets are machined directly in the block. The oilways in the block are arranged so that the oil filter, which is of the full-flow type, is directly attached to the right-hand side of the block. Mounted on the cylinder block and flywheel housing (type 2 engine) is a reinforcing bracket which absorbs vibrations (Fig. 13).

CYLINDER HEAD AND VALVES

The cylinder head (23) is attached to the block by means of bolts. All the combustion chambers are machined throughout and have separate inlet and exhaust ports, one for each valve.

The valves (4 and 8, Illustration A), which are fitted suspended in the cylinder head, are made of special steel and mounted in replaceable guides. The valve stems are chromed.

The cooling jackets are designed so that the air around the sparking plugs is also cooled. The water is also distributed by means of a pipe and directed towards the warmest parts of the engine.

CRANKSHAFT AND BEARINGS

The crankshaft (44) is made of drop-forged steel and has ground and case-hardened bearing journals. It is carried in five main bearings, the rear one of which also functions as a pilot bearing. There are drilled oilways in the crankshaft for the lubricating oil.

The big-end bearing shells, which are replaceable, consist of a steel backing with indium-plate lead-bronze bearing metal. Dabbit's metal is used for the main bearings.

CAMSHAFT AND VALVES TAPPETS

The camshaft (45) is made of special-alloy cast iron and has case-hardened cams. It is driven from the crankshaft through a gear train which has a reduction ratio of 2:1. The camshaft is guided

axially by means of an axial washer at the front end. The end float is determined by a spacing ring behind the camshaft gear. The valve tappets (27) are actuated directly by the camshaft. They are located in holes in the block above the camshaft and transfer the movement to the valves by means of push rods and rocker arms. There are no inspection covers for the valve tappets since they are accessible after the cylinder head has been removed.

CONNECTING RODS, PISTONS AND PISTON RINGS

The connecting rods (48) are made of drop-forged steel and are provided with a precision-machined bush which acts as a bearing for the gudgeon pin. The big-end bearing shells are precision-manufactured and are replaceable.

The pistons (46) are made of light-alloy and have two compression rings and one oil scraper ring. The upper compression ring is chromed in order to reduce cylinder wear.

The gudgeon pin (50) has a floating fit in both the piston and connecting rod. The axial movement of the gudgeon pin is limited by circlips in the gudgeon pin hole.

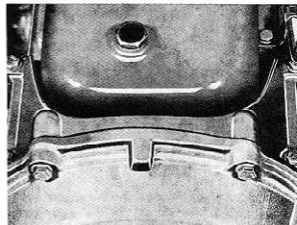

Fig. 13. Reinforcing bracket, cylinder block—flywheel housing, type 2 engine

POSITIVE CRANKCASE VENTILATION

The B 18 A engine is provided with positive crankcase ventilation, see Fig. 14.

This arrangement prevents crankcase gases from being released into the atmosphere. They are instead sucked into the engine through the intake manifold and take part in the combustion process. The residue is blown out through the exhaust pipe together with the other combustion residues.

Between the engine crankcase and intake manifold there is a connection which consists of an oil trap (8) attached to the valve inspection cover on the right-hand side of the engine (viewed from the front), and two rubber hoses (5 and 7) between which there is a control valve (6). The rubber hose (5) is connected to a nipple (2) screwed centrally in the equalizing pipe of the intake manifold.

The partial vacuum which occurs when the engine is running causes the crankcase gases combined with fresh air to flow from the crankcase to the intake manifold. The amount of flow is regulated by the control valve. Fresh air is supplied to the crankcase through the carburettor air filter via a nipple (1), rubber hose (3) and oil filler cap (4)

to the rocker arm casing, which is connected to the crankcase through the push rod holes. The oil filler cap, which is sealed, has a built-in flame trap. This flame trap, in the same way as the control valve, which also functions as a check valve, prevents flame from any backfiring in the carburettor or intake manifold from reaching the crankcase.

As the fresh air supply passes through the carburettor air cleaners, impurities are prevented from getting into the engine. Where there is a medium or high degree of partial vacuum in the crankcase (intake manifold), which happens during idling and when operating under a light load, the system functions as described above. When the partial vacuum in the crankcase is less than that in the air cleaner, which occurs at full load and/or with large flow quantities, no fresh air is supplied. Instead, the flow in the connection between the rocker arm casing and air cleaner reverses and the crankcase gases go both ways, partly through the control valve and partly through the air cleaner and carburettor to the intake manifold. In this way, the crankcase ventilation system can deal with relatively large quantities of crankcase gases without any escaping into the atmosphere.

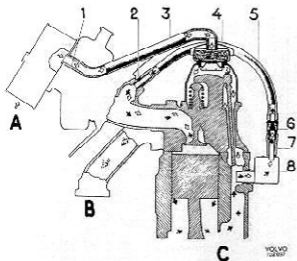

Fig. 14. Positive crankcase ventilation

- | | | |
|-------------------|------------------|-------------------|
| 1. Nipple | 5. Hose | A Fresh air |
| 2. Nipple | 6. Control gases | B Exhaust gases |
| 3. Hose | 7. Hose | C Crankcase gases |
| 4. Oil filler cap | 8. Oil trap | |

REPAIR INSTRUCTIONS

DISMANTLING THE ENGINE

After the engine has been lifted out of the vehicle, dismantling is carried out as follows. (Instructions for the individual parts are given under the separate headings concerned.)

1. Place the engine on the stand SVO 2520 with fixture SVO 2521. Check that the oil has been drained off.
2. Remove the starter motor and reinforcing plate on the lower front edge of the flywheel housing. Remove the flywheel housing together with the gearbox and then remove the clutch and flywheel.
3. Remove the rear flange, taking care not to damage the contact surfaces, thereafter the dynamo, water pump and distributor, the rocker casing, rocker arms, cylinder head and oil filter.
Remove the valve tappets with tool SVO 2424, see Fig. 15.
4. Remove the timing gear casing and the timing gears. Concerning tools, see under the heading "Replacing the timing gears". Remove the camshaft.
5. Remove the carbon ridge from the cylinder bores. Remove the sump, oil pump and con-

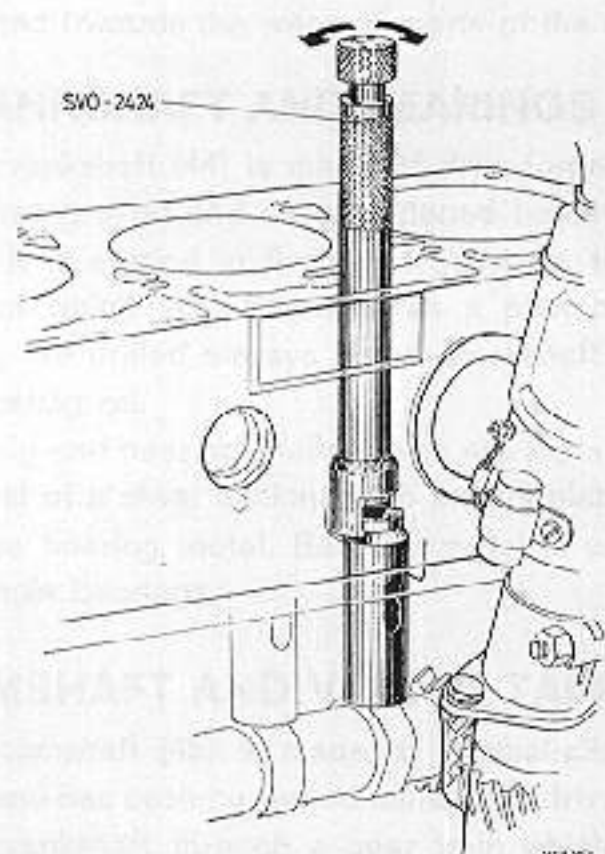

Fig. 15. Removing the valve tappets

necting rods with pistons. Replace the caps correctly on their respective connecting rods.

6. Turn the engine upside down and take out the crankshaft. Replace the caps correctly in their respective positions.

CLEANING

After dismantling, all the parts should be thoroughly cleaned. Parts made of steel or cast iron can be washed in a degreasing tank with a caustic soda solution. Light-alloy parts can, however, be destroyed by caustic soda so that they should preferably be cleaned with white spirit.

Pistons and bearing shells must never be washed in caustic soda. Rinse the parts with warm water and blow them dry with compressed air after ashing. Clean the oilways with particular thoroughness. All sealing plugs at the oilway openings in the cylinder block must be removed during the cleaning process.

ASSEMBLING THE ENGINE

When assembling the engine, follow the instructions for the parts concerned. Check the marking of the bearings according to Fig. 16. The main bearings are marked 1-5, and the big-end bearings 1-4, counting from the front.

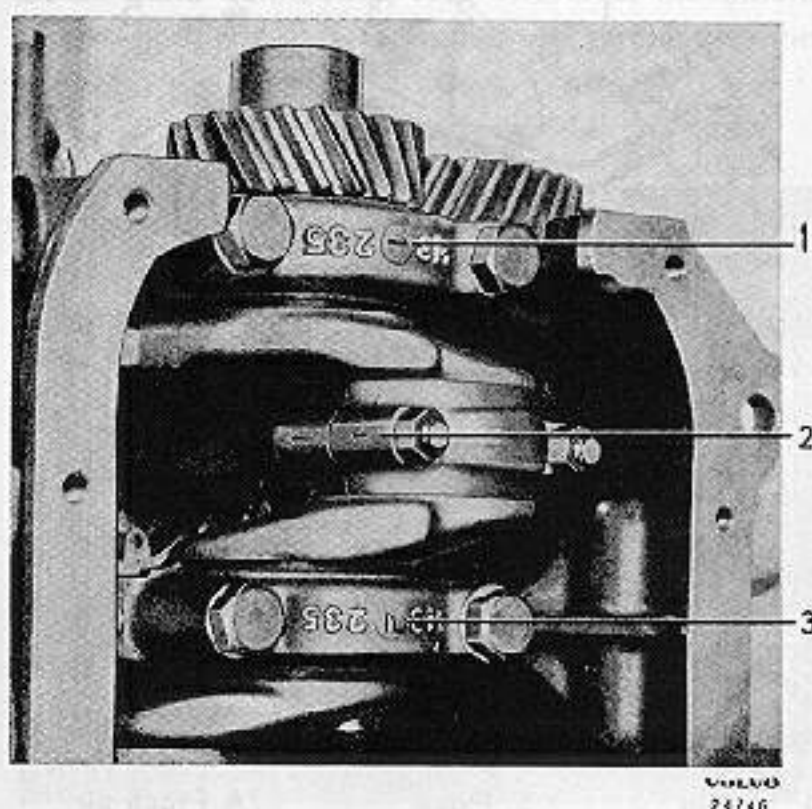

Fig. 16. Marking the main and big-end bearings
1. Main bearing No. 1 2. Big-end bearing No. 1 3. Main bearing No. 2

Check that all parts are clean and lubricate friction surfaces with oil before assembling. Always use new gaskets, split pins and lock washers. No adhesive should be used on the gaskets.

The seals in the ends of both the oil pump delivery pipe and the water pump pipes are in the form of rubber rings. These rings, which seal radially, are made of special rubber with very close tolerances. Only genuine Volvo parts should be used. Fitting is facilitated by coating the rings with soap solution. The rings are fitted on the pipes and then pressed into their correct positions before the attaching bolts are tightened. The oil pump flange should lie flush against the cylinder block before tightening.

The timing gear casing and rear sealing flange must be accurately centred when fitting. See under the headings "Replacing the timing gear casing" and "Fitting the rear sealing flange".

The big-end bearing bolts and nuts should be replaced with new ones when reconditioning.

The reinforcing bracket on the flywheel housing is fitted according to point 2 "Fitting" on page 13.

The cylinder head is fitted with the help of guide pins (SVO 2435). The bolts must be tightened in a certain sequence as shown in Fig. 17, in order to avoid unnecessary stresses. Check that the oil hole (1, Fig. 18) for lubricating the rocker arms is clear.

The pilot bearing (5, Fig. 19) should be lubricated before fitting with heat-resistant ball bearing grease. The bearing and protecting washer are held in position by a circlip (4).

The most important bolts and nuts should be tightened with a torque wrench, see "Tightening torques" in "Specifications".

VALVE GRINDING AND DECARBONIZING

1. Drain off the coolant from the radiator and cylinder block. To do this open the tap on the right-hand side of the engine and remove the plug at the bottom of the radiator.
2. Dismantle the throttle control. Disconnect the choke control.
3. Remove the air cleaner and carburettor.
4. Disconnect the exhaust pipe at the exhaust manifold and disconnect the hoses to the radiator as well as other connections to the cylinder head.

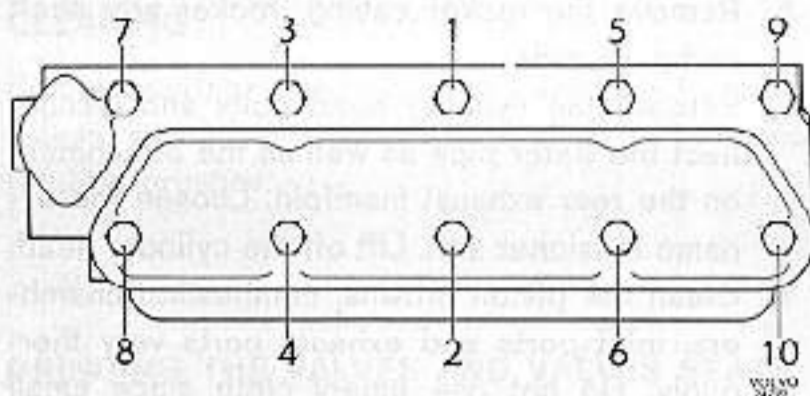

Fig. 17. Tightening sequence for cylinder head bolts

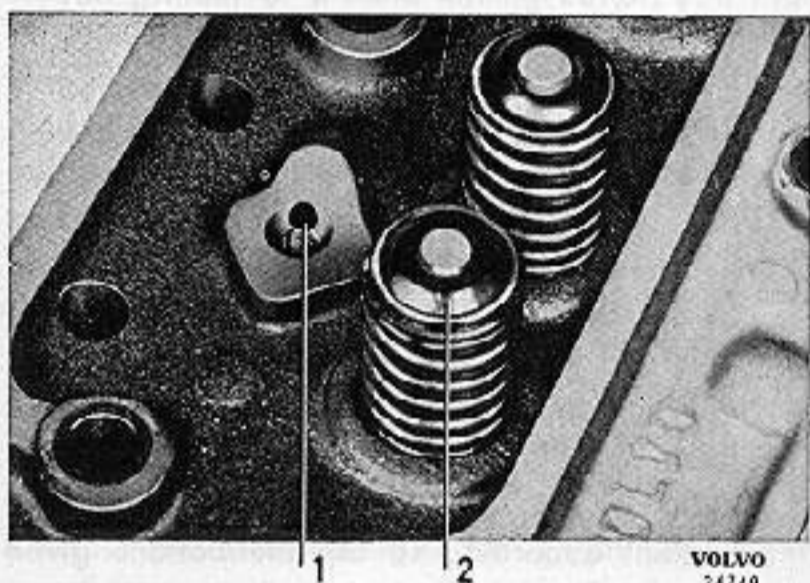

Fig. 18. Cylinder head

1. Oil hole
2. Rubber washer

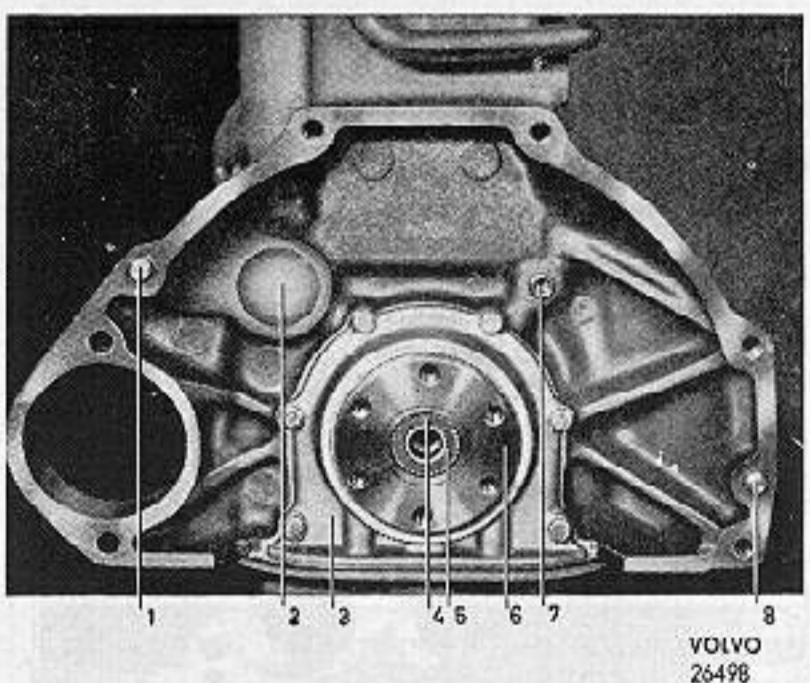

Fig. 19. Rear end of engine

1. Guide pin
2. Core plug
3. Sealing flange
4. Circlip
5. Pilot bearing
6. Crankshaft
7. Plug
8. Guide pin

- Remove the rocker casing, rocker arm shaft and push rods.
- Remove the cylinder head bolts and disconnect the water pipe as well as the attachment on the rear exhaust manifold. Loosen the dynamo tensioner arm. Lift off the cylinder head.
- Clean the piston crowns, combustion chambers, inlet ports and exhaust ports very thoroughly. Do not use emery cloth since small grinding particles can get in between the piston and cylinder walls and consequently cause scoring.
- Recondition the valve system as described under the heading "Cylinder head and valves".
- Fit the valves. Screw the guide pins SVO 2435 into the block, one in the front right-hand hole and the other in the left-hand rear hole, see Fig. 20. Install a new cylinder head gasket and new sealing rings for the water pump and fit the cylinder head. Screw out the gasket pins and fit the bolts in these holes as well. For tightening sequence and tightening torques, see Fig. 17 and at the end of "Specifications". Fit the other parts. Fill up with coolant according to the instructions given under "Filling with coolant when the system has been emptied".
- Adjust the tappet clearances. Run the engine for a short while. Check the running of the engine and re-adjust the tappet clearances. It is not necessary to re-tighten the cylinder head bolts.

CYLINDER HEAD AND VALVES

DISMANTLING

- Remove the rubber seals. Remove the valve springs by first compressing them with valve pliers and removing the valve cotters, after

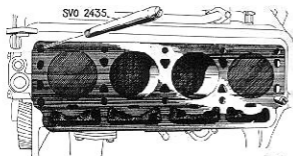

Fig. 20. Guide pins for fitting the cylinder head

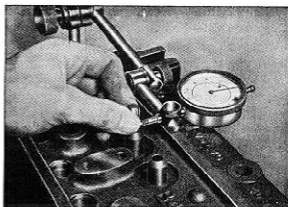

Fig. 21. Measuring valve stem clearance

- which the pliers are released. Place the valves in order in a valve rack.
- Measure the clearance between the stem and guides as shown in Fig. 21. With a new valve the clearance should not exceed 0.15 mm (0.006"). Also check that the valves are not excessively worn. See the specifications under the headings "Valve system" and "Wear tolerances".

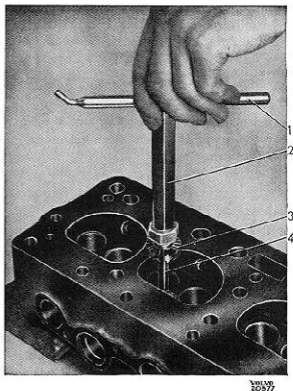

Fig. 22. Refacing the valve seats

1. Handle 2. Shaft 3. Miller 4. Pilot spindle

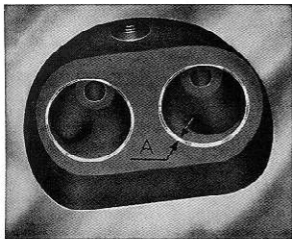

Fig. 23. Valve seat width
A—1.4 mm (0.055")

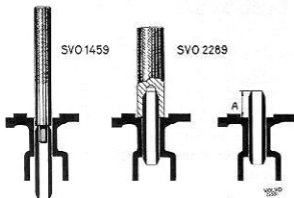

Fig. 24. Replacing the valve guides
A=21 mm (0.827")



Fig. 25. Testing the springs

CLEANING

Remove carbon and combustion deposits from the valves, combustion chambers and ports by using rotating brushes.

GRINDING THE VALVES AND VALVES SEATS

1. Grind the valves in a machine after they have been cleaned. Fit new valves if they are excessively worn.
2. Grind the valve seats. Use an electrically driven grinder or a hand milling cutter, see Fig. 22. A pilot spindle must be carefully fitted before work is started and any worn guides must be replaced with new ones.

The seat should be ground until a good sealing surface is obtained. The angle is 45° and the width of the sealing surface should be 1.4 mm (0.005"), see "A" Fig. 23. If the sealing surface is too wide after grinding, it can be reduced by using a 70° grinding stone from the inside and a 20° grinding stone from the outside.

3. Coat the valve sealing surfaces with a thin layer of fine grinding paste and lap in the valves against their seats.

Then clean the valves and seats and check that good sealing is obtained.

REPLACING THE VALVE GUIDES

1. Press out the old guides with tool SVO 1459.
2. Press in the new guides using drift SVO 2289 which gives the correct depth, see Fig. 24.
3. Check that the guides are free from burr and that the valves move easily in them.

ASSEMBLING

1. Check that the parts are in good condition and clean. Test the springs to ensure that they maintain the values given in the "Specifications". See Fig. 25.
2. Place the valves in position. Fit the lower rubber washer, valve spring, upper washer and cotter and finally the rubber ring.

REPLACING THE ROCKER ARM BUSHES AND GRINDING THE ROCKER ARMS

1. If wear amounts to 0.1 mm (0.004"), replace the rocker arm bush. Use tool SVO 1867 for pressing the bush both out and in, see Fig. 26. Then ream the bush with a suitable reamer until an accurate fit on the shaft is obtained, see Fig. 27. The hole in the bush should coincide with the hole in the rocker arm.
2. If necessary grind the pressure pad of the rocker arm in a special machine.

FITTING THE CYLINDER HEAD

1. Check that the cylinder head, the cylinder block, the pistons and cylinder bores are clean.
2. Check that the oilway to the rocker arm mechanism on the valve tappet side in the middle of the head is clean. In the cylinder head oil goes up through the bolt hole, between the bolt and hollow partition, through a diagonal oilway to the attaching bolt for the rocker arm shaft and then up into the shaft.
3. Screw down the guide pins SVO 2485, one in the front right and one in the left bolt hole, see Fig. 20. Fit a new cylinder head gasket and then fit the cylinder head. Screw in the cylinder

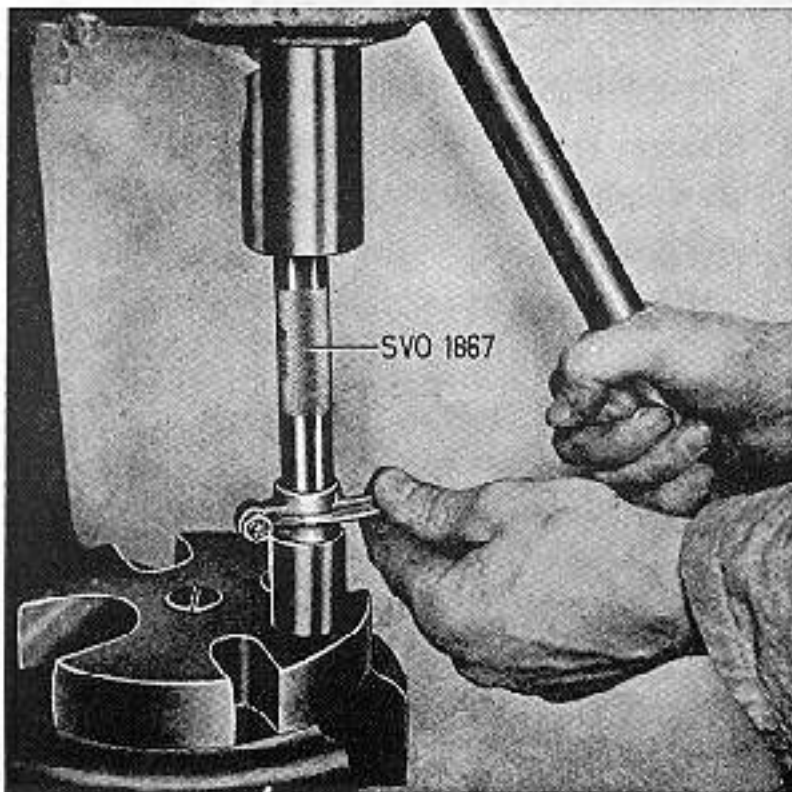

Fig. 26. Replacing the rocker arm bush

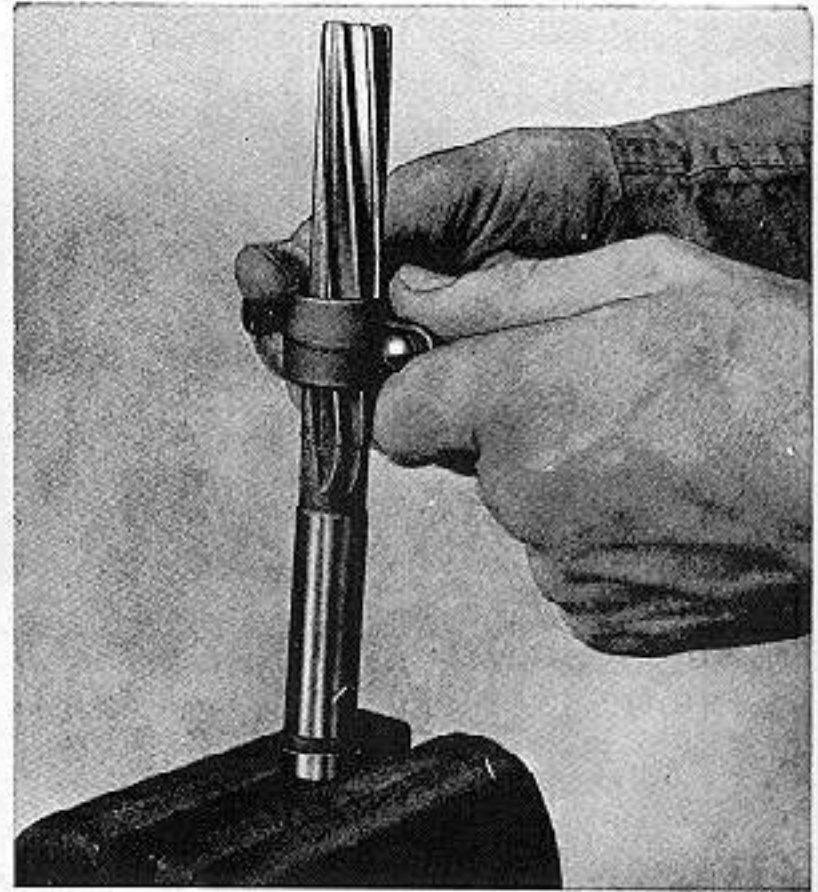

Fig. 27. Reaming the bush

head bolt lightly. Remove the last guide pins and also fit the bolts in these holes as well.

Tighten the bolts in the correct order and to the correct torque. See Fig. 17 and "Specifications".

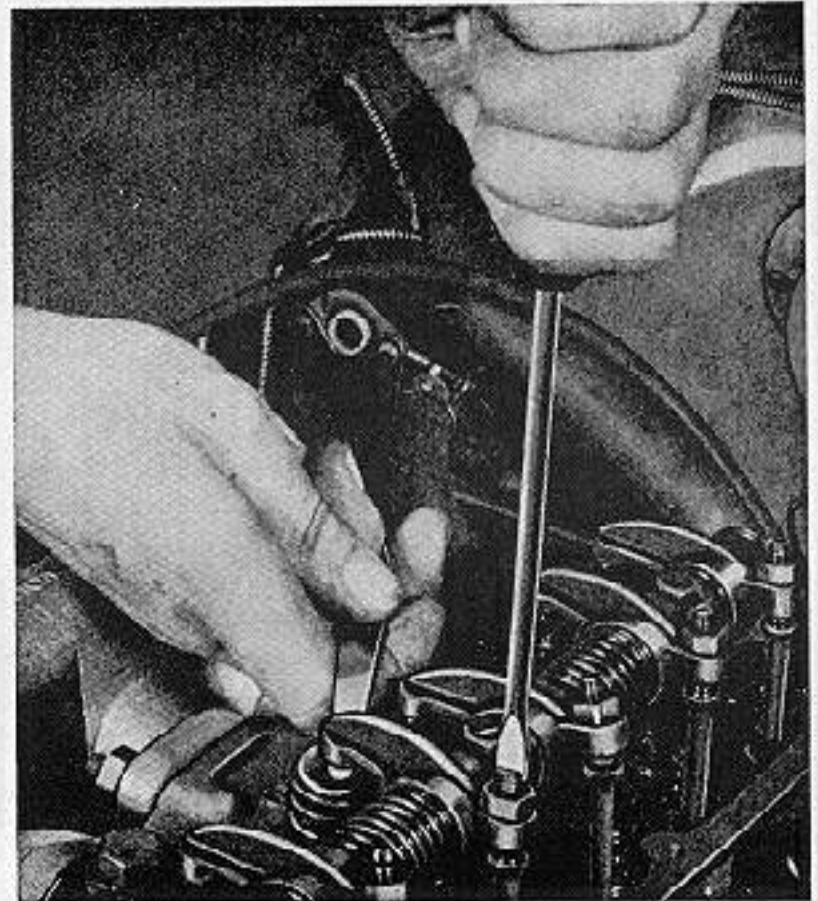

Fig. 28. Adjusting the valve clearance

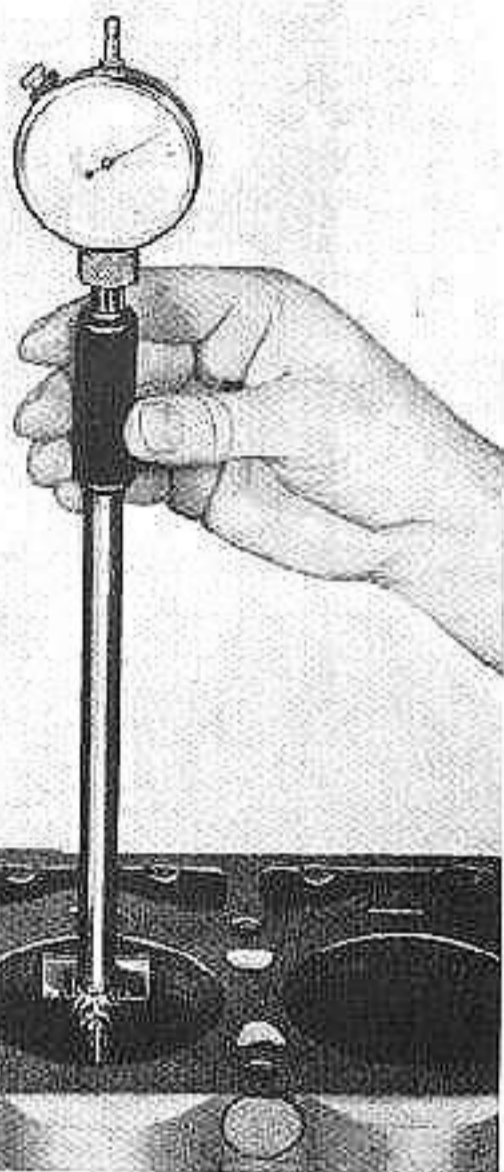

Fig. 29. Measuring the cylinder bore

4. Fit the rocker arm mechanism. Adjust the valve clearances. Fit the other parts.
5. Run the car for a short distance. Check that the engine is running well and adjust the valve clearances. See Fig. 28.

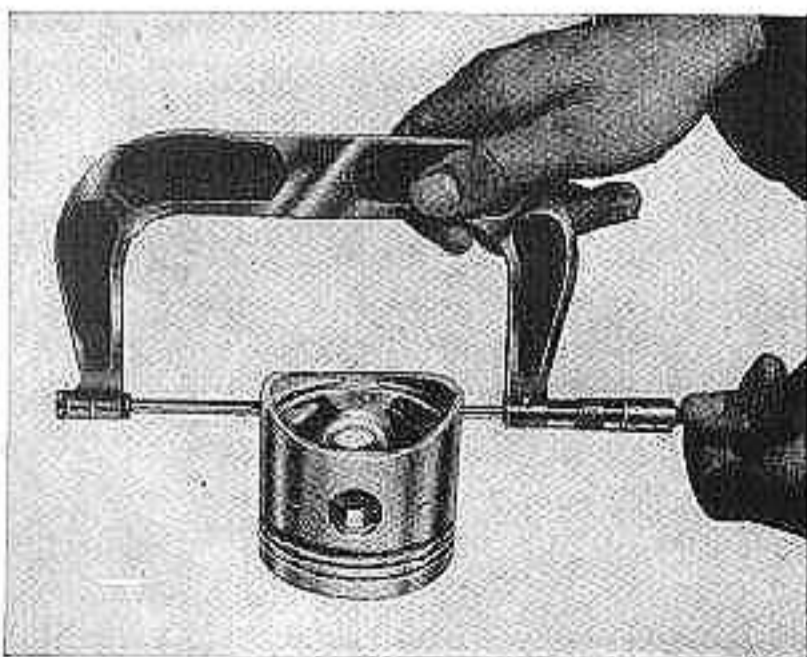

Fig. 30. Measuring the piston

It is not necessary to re-tighten the cylinder head.

ADJUSTING THE VALVE CLEARANCES

The valves clearances can be adjusted satisfactorily with the engine stationary, irrespective of whether or not it is cold or warm. The clearance is the same for both the inlet and exhaust valve. When adjusting, use two feeler gauges, one "Go" 0.40 mm (0.016") thick and the other "No-Go" 0.45 mm (0.018") thick. The clearance is adjusted so that the thinnest gauge can be inserted easily while the thicker one must not enter.

When the piston in No. 1 cylinder is at top dead centre (the compression stroke), valve Nos. 1, 2, 3 and 5 (counted from the front) are adjusted, and with the piston in No. 4 cylinder at top dead centre, valves Nos. 4, 6, 7 and 8.

CYLINDER BLOCK

MEASURING THE CYLINDER BORES

The cylinder bores are measured with a special dial indicator as shown in Fig. 29. A letter is stamped on each cylinder bore indicating the classification of the bore and piston (only on standard models).

Measuring should be carried out just below the top edge of the bore and only in the transverse direction of the engine.

PISTONS, PISTON RINGS AND GUDGEON PINS

MEASURING THE PISTONS

The pistons are measured with a micrometer at right angles to the gudgeon pin hole 12.5 mm (0.49") from the lower edge (early production) and 2.5 mm (0.098") from the the lower edge (late production), see Fig. 30.

FIT OF PISTONS IN CYLINDERS

The fit of the pistons in their respective cylinders is tested without the piston rings fitted. The clearance at right angle to the gudgeon pin hole is measured with a feeler gauge 1/2" wide and 0.03 mm (0.0012") thick attached to a spring balance. The force applied should be 1 kg (2.2 lb.). This

gives the average value for piston clearance. When the above-mentioned force is applied, the piston clearance obtained is equal to the thickness of the feeler gauge used. Feeler gauges which are 0.02 mm (0.0008") or 0.04 mm (0.0016") thick can therefore also be used. The test is carried out at several different depths, see Fig. 31. Standard bore cylinders have a letter stamped on which shows the dimensions, and the pistons concerned should be marked with the same letter.

PISTON RING FIT

In a new or re-bored cylinder

1. Push down the piston rings one after another in the cylinder bore. Use a reversed piston to ensure that the rings come into the correct position.
2. Measure the ring gap with a feeler gauge, see Fig. 32. The gap should be 0.25–0.50 mm (0.01–0.02"). If necessary, the gap can be increased with the help of a special file.
3. Check the piston rings in their respective grooves by rolling them in the groove as shown in Fig. 33. Also measure the clearance at a few points as shown in Fig. 34. See "Specifications" for measurements.

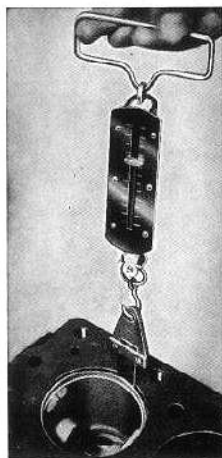

VOLVO
27245

Fig. 31. Checking the piston clearance

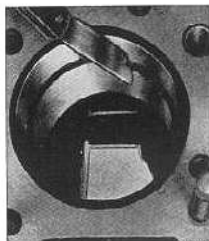

Fig. 32. Measuring the piston ring gap

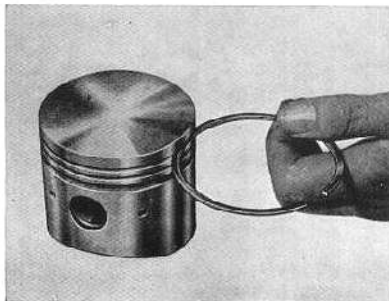

Fig. 33. Rolling piston ring in groove

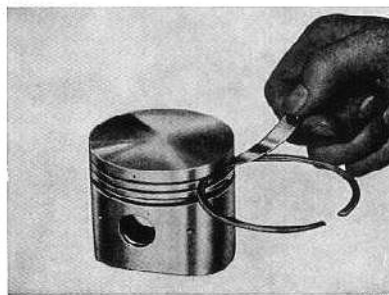

Fig. 34. Piston ring clearance in groove

In a worn cylinder bore

When checking the fit in a worn cylinder bore, the rings must be checked at the bottom dead centre position where the diameter of the bore is smallest.

GUDGEON PINS

The gudgeon pins are available in three oversizes 0.05 mm (0.002"), 0.10 mm (0.004") and 0.20 mm (0.008") larger than the standard diameter of 22.00

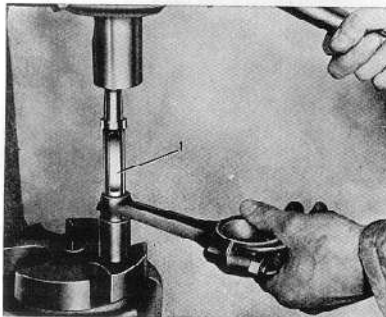

Fig. 35. Replacing bush in connecting rod

1=SVO 1807



Fig. 36. Gudgeon pin fit

mm (0.866"). If the gudgeon pin hole in the piston is worn so much that an oversize is necessary, the hole should first be reamed out to the correct measurement. Use a reamer fitted with a pilot guide and only take small cuts at a time.

The fit is correct when the gudgeon pin can be pushed through the hole by hand with light resistance.

CONNECTING RODS

REPLACING THE BUSHES

If the old bush in a connecting rod is worn, press it out by using tool SVO 1867 and press in a new bush with the same tool, see Fig. 35. Make sure that the lubricating holes index with the holes in the connecting rod. Then ream the bush to the correct fit. The gudgeon should slide through the hole under light thumb pressure but without any noticeable looseness, see Fig. 36.

STRAIGHTENING

Before being fitted, the connecting rod should be checked for straightness, twist any S-distortion. Straighten them if necessary, see Fig. 37. Nuts and bolts should be replaced with new ones when reconditioning is being carried out.

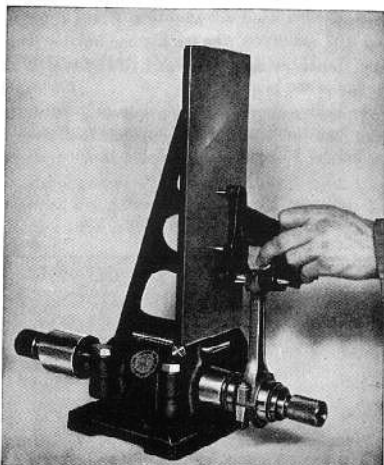

Fig. 37. Checking the connecting rod

ASSEMBLING AND FITTING THE PISTON AND CONNECTING ROD

When assembling, make sure that the piston is turned correctly so that the arrow (early production) and slot (late production) on top of the piston faces forwards as shown in Fig. 38. If the piston is turned the wrong way, this will cause a loud noise. The number marking on the connecting rod should be turned to face away from the camshaft side. The gudgeon pin is then fitted, the circlip placed in position and the piston rings fitted.

Use piston ring grips when fitting the rings, see Fig. 39. The compression rings are marked "TOP" and the upper ring on each piston is chromed. Place the bearing shells in position.

Turn the rings so that the gaps do not come directly under one another. Then lubricate the piston and bearing surfaces.

Use fitting ring SVO 2176, Fig. 40, when fitting the piston in the cylinder bore. Tighten the connecting rod bolts with a torque wrench, see "Specifications" for the correct value.

CRANKSHAFT

After the crankshaft has been cleaned, its journals must be measured with a micrometer. Measuring should be carried out at several points round the circumference and along the longitudinal axis of each journal. Out-of-roundness on the main bearings journal should not exceed 0.05 mm (0.002"), and 0.07 mm (0.003") on the big-end bearing journals. Taper should not exceed 0.05 mm (0.002") on any of the journals.

If the values obtained are close to or exceed the wear limit mentioned above, the crankshaft should be ground to undersize. Suitable bearing shells

are available in five undersizes. The measurements concerned are included in the "Specifications". Check that the crankshaft is straight to within 0.05 mm (0.002") by using a dial gauge. The crankshaft is placed on two V-blocks and a dial gauge placed against the centre bearing journal, after which the crankshaft is rotated. If necessary, straighten the crankshaft in a press.

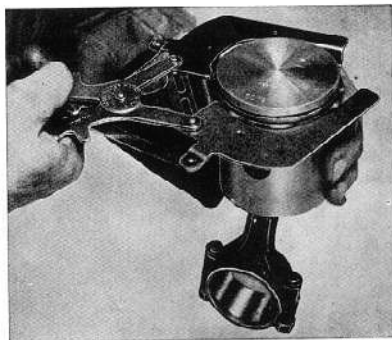

Fig. 39. Fitting the piston rings

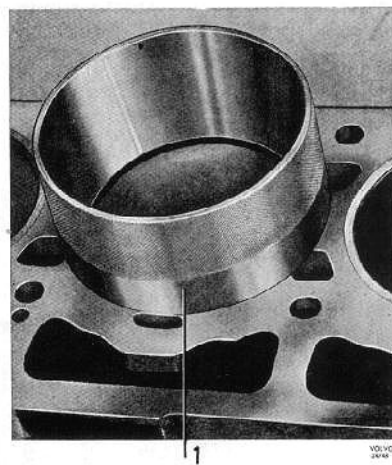

Fig. 40. Fitting the piston
1. Fitting tool SVO 2176

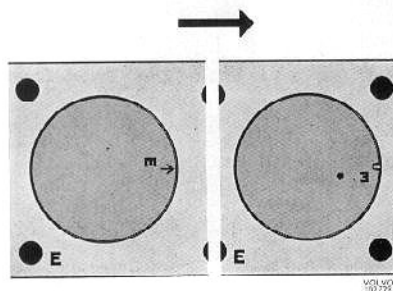

Fig. 38. Marking on pistons and cylinder block

GRINDING THE CRANKSHAFT

Before the crankshaft is ground, a check should be made to ensure that it is straight, this being done as previously described. Grinding is carried out in a special machine whereby the main bearing journals and the big-end bearing journals are ground to identical measurements. These measurements, which are given in "Specifications", must be carefully followed in order to ensure correct clearance with ready-machined bearing shells.

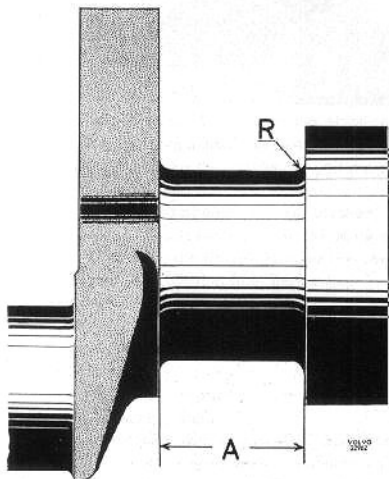

Fig. 41. Bearing journal

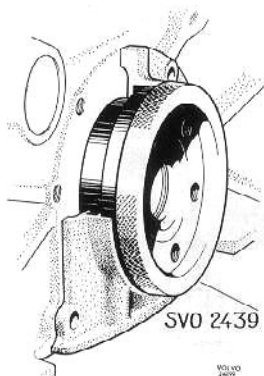

Fig. 42. Centring the rear sealing flange

On no account must the bearing shells be scraped or the bearing caps filed.

The fillets and the ends of the journals should have a radius of 2.0–2.5 mm (0.080–0.100") on all journals, see Fig. 41. The width measurement (A) for the pilot bearing depends on the size of the journal and should be ground in order to obtain the correct measurement.

After grinding has been completed, all burr should be carefully removed from the oilway openings and all the journals lapped with a fine grinding paste to the finest possible surface finish. The crankshaft should then be washed. All the oilways should be cleaned with particular thoroughness in order to remove all metal chippings and grinding residue.

MAIN AND BIG-END BEARINGS

In addition to standard sizes, bearing shells are available in undersizes of 0.010", 0.020", 0.030", 0.040" and 0.050". The rear main bearing shells are provided with flanges and have a larger width relative to their size.

If the crankshaft has been ground to the correct measurement, the correct bearing clearance is automatically obtained when the bearing shell concerned is fitted. The bearing shells must not be scraped and the caps must never be filed in order to obtain a closer bearing fit.

The bolts should be tightened with a torque wrench, see "Specifications" for information concerning tightening torques.

FITTING THE REAR SEALING FLANGE

1. Make sure that the seal is in good condition and that the flange is clean. The drain hole must not be blocked by incorrect fitting of the sump gasket. The sealing ring must not be fitted in the flange.
2. Fit on the sealing flange but do not tighten the bolts.
3. Centre the flange with sleeve SVO 2439, Fig. 42. Turn the sleeve round while tightening the bolts and adjust the position of the flange if the sleeve jams. Check that the flange comes flush against the cylinder block on the underside. After final tightening, check that the sleeve can rotate easily.
4. Fit a new felt ring and place on the washer and circlip. Press the circlip into position with the centring sleeve. Check that the circlip engages in its groove.

GRINDING THE FLYWHEEL

If the wear surface of the flywheel is uneven or burnt, the surface can be ground in a saddle-mounted grinding machine, see Fig. 43. Not more than 0.75 mm (0.03") of the original thickness must be ground off.

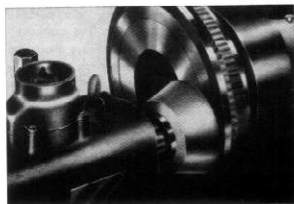

VOLVO
20173

Fig. 43. Grinding the flywheel

PILOT BEARING FOR CLUTCH SHAFT

The pilot bearing circlip and protecting washer are removed, the pilot bearing pulled out with tool SVO 4090 and checked after having been washed in white spirit. If the bearing is worn, it should be replaced with a new one. Before fitting, pack the bearing with heat-resistant ball bearing grease. The bearing is fitted with drift SVO 1426, after which the protecting washer and circlip are fitted.

REPLACING THE OIL SEAL IN TIMING GEAR CASING

- 1 Release the fan bolt. Loosen the attachment of the stabilizer at the frame.
2. Screw out the bolt in the crankshaft. Remove the belt pulley.
3. Remove the circlip for the washer which retains the felt ring. Remove the washer and felt ring.

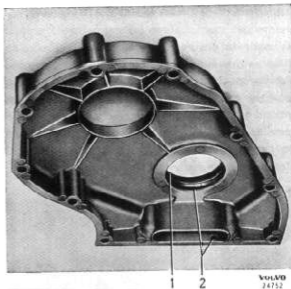

VOLVO
24752

Fig. 44. Timing gear casing

1. Sealing ring
2. Drain holes

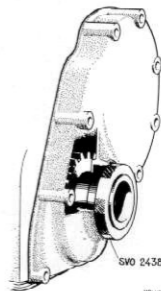

VOLVO
24752

Bild 45. Centring the timing gear casing

Check that the casing is correctly fitted by inserting a 0.10 mm (0.004") feeler gauge in the gap between the casing and hub on the crankshaft and moving it all round. If the feeler gauge jams at any point, the casing should be centred, see under "Replacing the timing gear casing".

4. Fit a new felt ring. Place the washer in position and fit the circlip. Check that the circlip fits properly in position.
5. Fit the remaining parts and tension the fan belt.

REPLACING THE TIMING GEAR CASING

1. Loosen the fan belt. Remove the fan and pulley on the water pump. Disconnect the stabilizer attachment from the frame.
2. Remove the bolt for the crankshaft belt pulley and remove the pulley.
3. Remove the timing gear casing. Slacken a couple of extra bolts for the sump and be careful not to damage the gasket. Remove the circlip, washer and felt ring from the casing.
4. Make sure that the gaskets are in good condition and that the drain hole is open and clean inside the timing gear casing which is to be fitted, see Fig. 44.
5. Place the casing in position and fit the bolts without tightening them.
6. Centre the casing with sleeve SVO 2438, see Fig. 45. Turn the sleeve while tightening and adjust the position of the casing so that the sleeve is not jammed. Check after final tighten-

in of the casing that the sleeve can be easily rotated without jamming.

7. Fit a new felt ring, washer and circlip, Push them into their position with the centring sleeve SVO 2438. Check that the circlip has engaged in its groove.
8. Fit the other parts and tension the fan belt. See "Specifications" for the tightening torque. Fix the stabilizer attachments firmly to the frame.

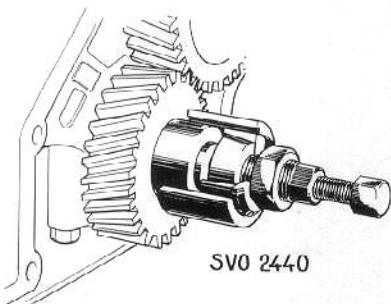
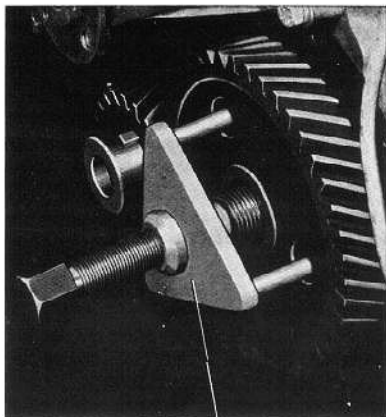

Fig. 46. Removing the hub on the crankshaft



SVO 2250
VOLVO
26495
Fig. 47. Removing the camshaft gear

REPLACING THE TIMING GEARS

1. Drain off the coolant and remove the cover plate and radiator.
2. Carry out operations 1-3 in previous section.
3. Remove the hub from the crankshaft with puller SVO 2440. See Fig. 46.

Before applying the tool, its large nut must be screwed backwards so that the cone is not tensioned. The centre bolt should also be screwed back.

Then apply the tool, screw in the large nut so that the hub is firmly held and pull it off by screwing in the centre bolt.

4. Remove the camshaft nut and pull off the gear by using puller SVO 2250, see Fig. 47.

5. Full off the crankshaft gear by using puller SVO 2405, Fig. 48. Screw out the oil nozzle, blow it clean and then refit it as shown in Fig. 51. The gears are lubricated by oil fed through this nozzle.
6. Fit the crankshaft gear by using tool SVO 2407 and the camshaft gear by using SVO 2408, see Figs. 49 and 50. Fit the hub on the crankshaft. Do not push the camshaft backwards so that the seal washer on the rear end loosens. Check that the gears have the correct position relative to each other, as shown in Fig. 51. Tool SVO 2407 has wrench flats, intended for turning the crankshaft.
7. Measure the tooth flank clearance as shown in Fig. 52. Also measure the end float of the camshaft, this being determined by means of a spacer ring behind the camshaft gear. See "Specifications" for the current values.
8. Centre and fit the timing gear casing and the other parts as described in points 4-8 in the previous section.

POSITIVE CRANKCASE VENTILATION

OVERHAUL

At intervals of 40 000 (25 000 miles) or less, depending on the driving conditions, change the valve (6), see Fig. 14.

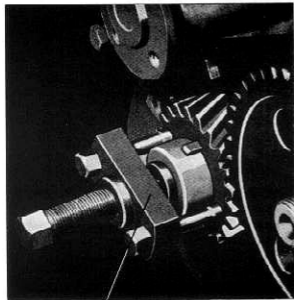

SVO 2405

VOLVO
24828

Fig. 48. Removing the crankshaft gear

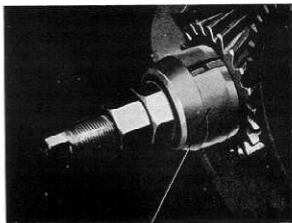

SVO 2407

VOLVO
24829

Fig. 49. Fitting the crankshaft gear

At the same time remove the oil trap (8), the hoses (5 and 7) as well as the nipple (2) from the engine and clean them carefully. If the rubber hoses are in poor condition, then replace them.

Make sure that the valve with the correct designation (CV-58C) is fitted. The wrong type of valve can result in poor ventilation or high oil consumption.

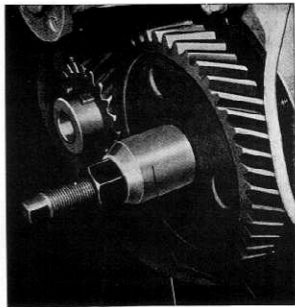

SVO 2408

VOLVO
24831

Fig. 50. Fitting the camshaft gear

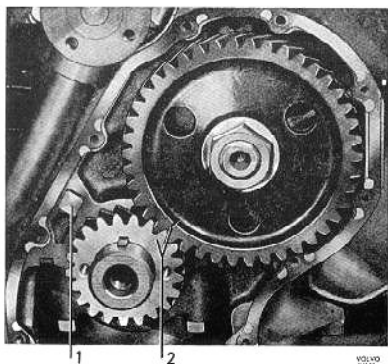

Fig. 51. Marking on timing gears

1. Oil nozzle 2. Markings

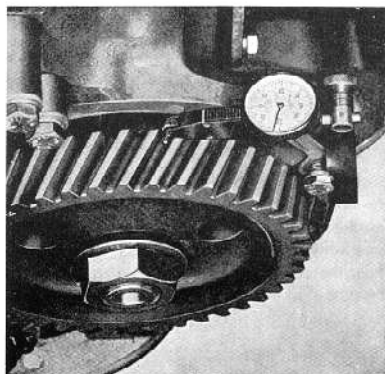

Fig. 52. Measuring the tooth flank clearance

LUBRICATING SYSTEM

DESCRIPTION

The engine has a force-feed lubricating system, see Fig. 53. The pressure is provided by a gear pump which is driven from the camshaft and fitted under the crankshaft in the pump. The gear pump forces the oil past the relief valve, which is also

fitted on the pump, through the oil filter and then through oilways out to the various lubricating points. All the oil supplied to the lubricating points therefore first passes through the oil filter.

Fig. 53. Lubricating system

1. Oil pump
2. Sump
3. Nozzle
4. Oil filter

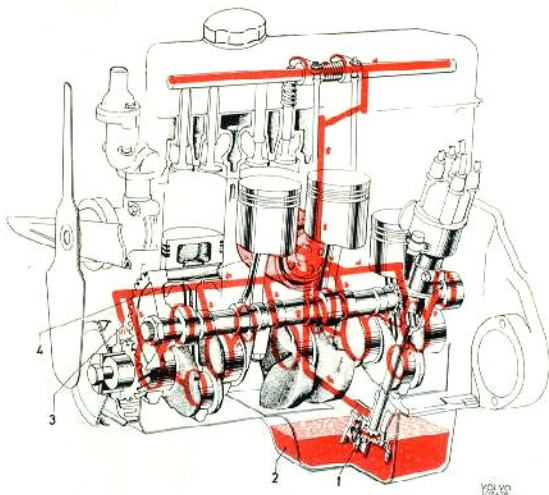

OIL PUMP, RELIEF VALVE

The oil pump, see Fig. 54, is of the gear type and is driven through a gear train from the camshaft. The delivery pipe from the pump to the cylinder block does not have a screwed union and is automatically tightened in position when the attaching bolts for the pump are tightened. At each end of the pipe there are sealing rings made of special rubber. The relief valve is fitted directly on the pump and consists of a spring-loaded ball. The ball has a cylindrical guide with a stop at the end position and therefore operates flexibly. Even at idling speed there is a certain amount of overflow, so that the oil pressure is then relatively low.

OIL FILTER

The oil filter (see Fig. 55), which is manufactured as a single unit complete with element, is of the full-flow type and is screwed directly onto the cylinder block. The oil which is fed out to the various lubricating points in the engine first passes through the oil filter element which is made of special paper. In the oil filter there is a by-pass valve which allows the oil to by-pass the element if resistance to flow should become excessive. When replacing the filter the old one is discarded completely and a new one fitted.

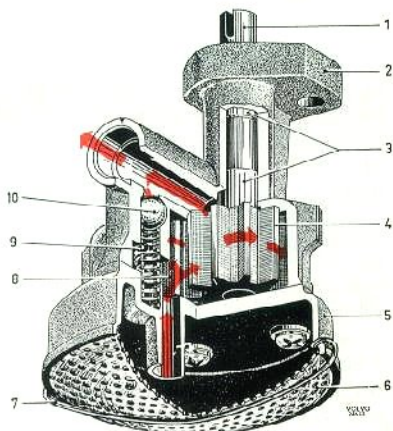

Fig. 54. Oil pump

- | | |
|-----------------|----------------------------|
| 1. Drive shaft | 6. Strainer |
| 2. Pump body | 7. Retainer clip |
| 3. Bushes | 8. Drive gear |
| 4. Driving gear | 9. Spring for relief valve |
| 5. Cover | 10. Valve ball |

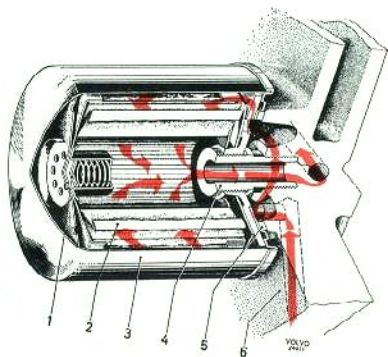

Fig. 55. Oil filter

- | |
|-------------------|
| 1. Overflow valve |
| 2. Element |
| 3. Body |
| 4. Nipple |
| 5. Gasket |
| 6. Cylinder block |

REPAIR INSTRUCTIONS

REPLACING THE OIL FILTER

The oil filter (Fig. 55) is, together with the element and relief valve, screwed as a complete unit on to a nipple fitted in the cylinder block.

The filter should be replaced every 10 000 km (6 000 miles), when the old filter is discarded. With a new or reconditioned engine the filter should also be changed for the first time after 5 000 km (3 000 miles).

1. Remove the old filter with the help of chain tongs as shown in Fig. 57.
2. Coat the rubber gasket (1, Fig. 56) of the new filter with oil and make sure that the contact surface for the oil filter is free from dirt. By coating it with oil, the gasket slides into better contact with the sealing surfaces. Screw on the filter by hand until it just touches the cylinder block.

3. Screw on the oil filter a further half turn by hand. **Chain tongs must not be used when fitting.** Start the engine and check that there is no leakage at the joint. Top up with oil if necessary.

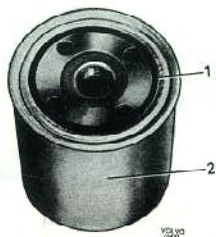

Fig. 56. Oil filter ready for fitting

- | | |
|-------------------|-----------|
| 1. Gasket (oiled) | 2. Filter |
|-------------------|-----------|

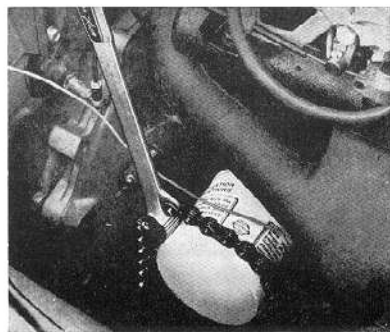

Fig. 57. Removing the oil filter

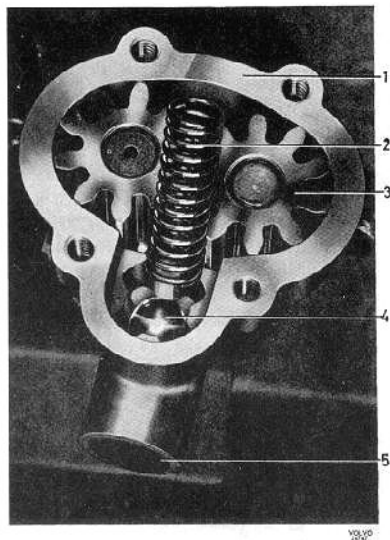

Fig. 58. Oil pump

- | | |
|----------------------------|----------------------|
| 1. Pump body | 4. Valve ball |
| 2. Spring for relief valve | 5. Hole for oil pipe |
| 3. Gear | |

OIL PUMP AND RELIEF VALVE

After the pump has been dismantled and cleaned, check that all the parts are in good condition. Test the relief valve spring (2, Fig. 58), see "Specifications" for the values concerned.

Check that the tooth flank clearance is 0.15–0.35 mm (0.006–0.014") see Fig. 59.

Measure the end float, 0.02–0.10 mm (0.0008–0.0040") with the help of a feeler gauge and a new cover or the old one if it is not noticeably worn. If the bushes (or shaft) are worn, replace them with new one. Note that the driving shaft with gear is replaced as a single unit.

The new bushes should be reamed after pressing in with a reamer provided with a pilot guide.

The sealing rings at the ends of the delivery pipe are made of special rubber and are manufactured to very close tolerances, see Fig. 61. Use only genuine Volvo spare parts. The delivery pipe must be clamped in its correct position first in the oil pump and then the oil pump and pipe together clamped against the block. The pump connecting flange should lie flush against the block before being tightened. Before being fitted, the rubber rings on the pipe can be coated with soap solution since this enables the pipe to take up its position more easily. Tap lightly on the pipe with a soft mallet if necessary.

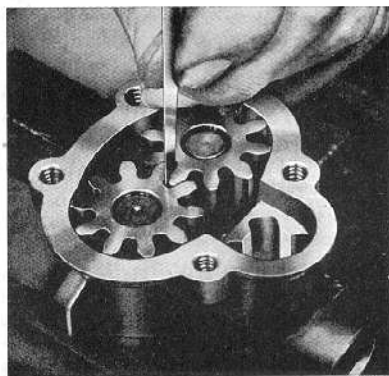

Fig. 59. Measuring tooth flank clearance

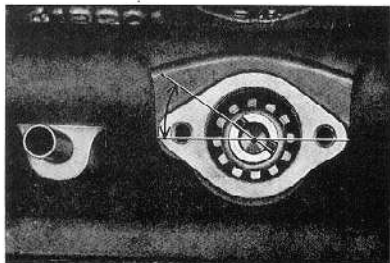

Fig. 60. Position of distributor drive pinion

A = approx. 35°

OILWAYS

All oilways must be cleaned particularly carefully before the parts are fitted on the engine in order to avoid damage to the bearings, bearing journals and other components.

To clean the cylinder block water channels, remove the core plugs and after cleaning the channels and blowing them dry, fit new plugs.

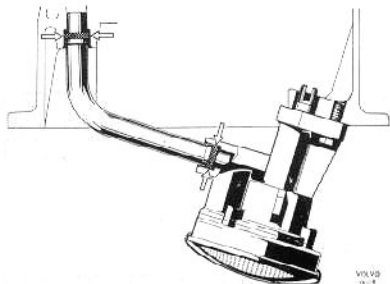

Fig. 61. Sealing rings on delivery pipe

FITTING THE OIL PUMP

When the engine is at upper dead centre and ready for firing on No. 1 cylinder, fit the drive for the oil pump and the distributor. The small part of the groove should face obliquely upwards-backwards and the groove should be set to an angle of 35° to the longitudinal direction of the engine, see A, Fig. 60. Make sure that the shaft fits into its groove on the pump shaft. (N.B. When the timing gear drive marks are opposite each other, the piston for the No. 4 cylinder is at the top dead centre position, the firing position.)

FUEL SYSTEM

DESCRIPTION

CARBURETTOR, ZENITH (Engine, type 1)

Type 1 engine has a Zenith down-draught carburettor, type designation 36 VN. The carburettor is illustrated in Figs. 62 and 63.

Fuel feed is controlled by fixed jets fitted in an emulsion block with a nozzle which opens out into the carburettor venturi. The emulsion block also has air channels so that a certain amount of air can be mixed with the fuel at an early stage.

The carburettor has a hand-regulated choke, rapid idling device, acceleration pump and economizer valve. The function of the carburettor is described under the following headings.

1. Float system.
2. Choke device with fast idling.
3. Idling system.
4. Main jet and compensation jet.
Economizer valve.
5. Acceleration pump.

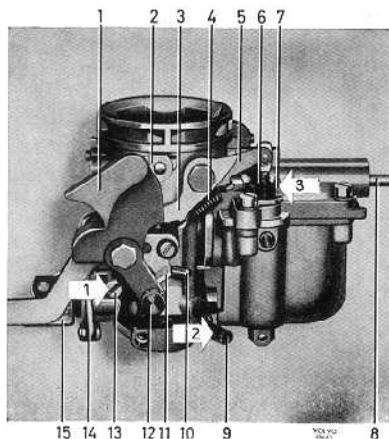

Fig. 62. Carburettor

- | | |
|---|-------------------------------------|
| 1. Lever with guide | 9. Idle adjusting screw |
| 2. Lever for choke flap | 10. Vacuum connection |
| 3. Rear lever | 11. Stop |
| 4. Spring | 12. Attachment for choke control |
| 5. Front lever | 13. Idle adjusting screw |
| 6. Plunger rod | 14. Link |
| 7. Washer for adjustment of stroke length | 15. Connection for throttle control |
| 8. Fuel inlet | |

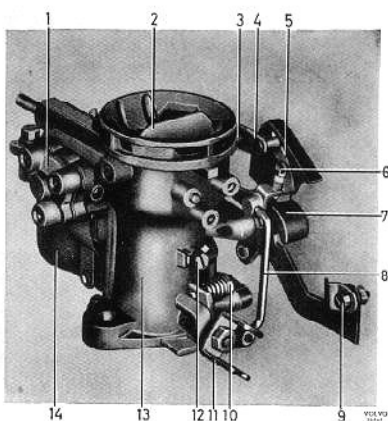

Fig. 63. Carburettor

- | | |
|------------------------------|----------------------------|
| 1. Economizer valve | 8. Link |
| 2. Choke flap | 9. Attachment |
| 3. Spring | 10. Idle adjusting screw |
| 4. Lever for choke | 11. Connector |
| 5. Lever with guide | 12. Lock screw for venturi |
| 6. Fast idle adjusting screw | 13. Carburettor housing |
| 7. Fast idling cam | 14. Floatchamber |

1. FLOAT SYSTEM

The float keeps the fuel at the correct level. When the fuel has increased to this level the float (4, Fig. 64) is lifted upwards and pushes the needle in the valve (2) against its seat through the medium of the float arm so that the flow of fuel is cut off. When the chamber level goes down the same procedure is repeated but in the reverse direction. The float bowl is ventilated through a hole (1) which is connected at the top with the upper part of the carburettor. The float is made of nylon and is fitted with a fixed arm.

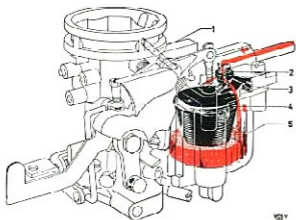

Fig. 64. Float system

1. Ventilation hole
2. Float valve
3. Lock spring
4. Float
5. Float chamber

has started and the degree of vacuum increases, the throttle can open itself to a certain extent, since the closing force is obtained from the spring on the choke spindle. This eliminates the risk of excessively rich fuel/air mixture when the choke is completely or almost closed. When the choke knob is pushed in again, the choke flap is forced to open fully since the flap lever pin (6) runs in a groove on the cam-shaped lever.

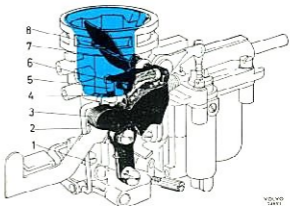

Fig. 65. Choke device with fast idling

1. Attachment for choke control
2. Link
3. Cam (for fast idling)
4. Lever with cam slot for choke flap
5. Fast idling adjusting screw
6. Pin
7. Spring
8. Choke flap

2. CHOKE DEVICE WITH FAST IDLING

In order to enrich the fuel/air mixture when a cold engine is started, the choke system is used and this is operated from the knob on the dashboard. When the choke control is pulled out on starting, the cam-shaped lever (4, Fig. 65) is actuated. This influences the choke flap (8) through the spring (7) on the flap spindle so that it closes, thereby resulting in a higher degree of vacuum and consequently a higher rate of fuel flow. When the engine

One of the cams on the choke lever (3) also actuates the throttle flap through the rapid idling screw (5) and the link (2). This means that the throttle flap opens at the same time as the choke flap closes. The degree to which the throttle flap opens relative to the closing of the choke flap is determined by various settings of the screw (5). This fast idling device enables the driver to give the engine higher idling speed during the warming-up period and thus avoid the risk of the engine stalling.

3. IDLING SYSTEM

While the engine is idling, the throttle flap is almost completely closed (regulated by means of a stop screw (7, Fig. 66) whereby the degree of vacuum around and under the flap is very large. Suction through the idling channel (4) will then be considerable and fuel will be sucked up from the channel above the main jet (5) through a hole and the idling jet (3) to the idling channel which opens out into the carburettor venturi with one large and two small holes. Air is supplied both through a hole (1) under the choke flap and an air jet (2) above the idling jet.

The fuel/air mixture is controlled by means of an idle fuel adjusting screw (8) by means of which the flow area for the fuel/air mixture can be varied. Since a certain amount of air passes through the throttle flap, the fuel/air mixture being fed to the engine during idling will be richer if the screw is screwed out and leaner if it is screwed in.

The two small holes (9) just above the throttle flap supply a mixture of air and fuel when the throttle flap opening is rather larger and thus co-operate with the variable hole. In this way a smooth transition is obtained.

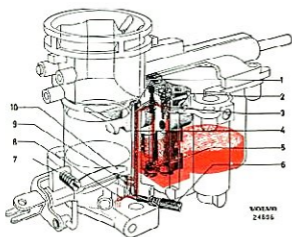

Fig. 66. Idling system

- | | |
|-------------------|-------------------------|
| 1. Air hole | 6. Idle adjusting screw |
| 2. Idling air jet | 7. Stop screw |
| 3. Idling jet | 8. Venturi |
| 4. Idling channel | 9. Transition holes |
| 5. Main jet | 10. Throttle flap |

4. MAIN JET AND COMPENSATION JET. ECONOMIZER VALVE

A large part of the fuel being fed to the engine when it is under loading and running at high speed passes through the main jet (4, Fig. 67). The main jet alone cannot supply a sufficiently well-balanced amount of fuel under all conditions of operation and is therefore combined with a compensation jet (3) which works in co-operation with the main jet.

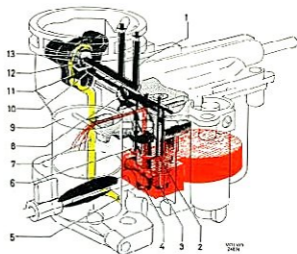

Fig. 67. Jets and economizer valve

- | | |
|---------------------|------------------|
| 1. Air channels | 8. Air jet |
| 2. Emulsion block | 9. Venturi |
| 3. Compensation jet | 10. By-pass hole |
| 4. Main jet | 11. Diaphragm |
| 5. Vacuum channel | 12. Valve disc |
| 6. Air holes | 13. Spring |
| 7. Vacuum channel | |

Both these jets are fitted in an emulsion block (2) and open out with a nozzle into the carburettor venturi. When it passes through the emulsion block, the fuel is mixed with a certain amount of air, whereby it can mix more easily with the large quantity of air entering the engine through the carburettor venturi. The amount of air supplied to

the emulsion block passes through a hole above the main jet space as well as through channels (1), and the air jet (8). The amount of air added is varied with the help of the economizer valve.

The space above the compensation jet forms a reservoir for fuel. High speed means a large rate of flow. The fuel then passes at a higher velocity through the hole in the wall to the main jet channel, whereby the level sinks down to the hole and an increased air flow results.

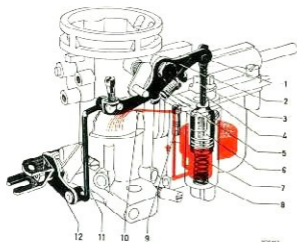

Fig. 68. Acceleration pump

- | | |
|--------------------------------------|----------------------|
| 1. Front part of lever | 7. Spring |
| 2. Rear part of lever | 8. Inlet valve |
| 3. Washer for limiting stroke length | 9. Outlet valve |
| 4. Plunger rod | 10. Acceleration jet |
| 5. Spring | 11. Link |
| 6. Plunger | 12. Lever |

From the air channels (1) air is supplied to the three channels (5) in the wall towards the space above the main jet. When the fuel level in this space sinks, more air is supplied and this air is mixed with the fuel.

With the help of the economizer valve, the fuel/air mixture is supplied with an extra amount of air when the degree of vacuum in the carburettor venturi is large.

The economizer valve disc (12) is attached to a diaphragm (11) and forced against the seat by a spring (13). In this position air supply is obtained from the upper channels only through the small hole (10) at the diaphragm.

On the back of the diaphragm, however, there is a connection with the lower part of the venturi through a channel (7). When the degree of vacuum in this increases, for example when driving quietly without any great degree of loading, the valve lifts from its seat and also flows into the emulsion block through the centre hole in the valve disc.

If the degree of loading should increase, for example during acceleration, the degree of vacuum is decreased and the spring forces the disc back against its seat, whereby the supply of air decreases and the fuel/air mixture again becomes richer.

5. ACCELERATION PUMP

When the throttle is opened quickly, there is a tendency for the fuel/air mixture to be too lean, a contributory reason being that air moves more quickly than fuel and thus reaches the engine more rapidly.

In order to compensate for this sudden weakening of the mixture, a certain amount of fuel is sprayed with the help of the acceleration pump directly into the carburettor venturi.

The pump plunger (6, Fig. 13), located in a cylinder integral with the side of the float chamber, is actuated when pressed down by a lever with a spring-loaded joint. The pump plunger stroke can thus easily be varied by turning a washer with a cam (3), whereby the front part of the lever is stopped by a check, higher or lower depending upon the position of the washer. The last part of the rear lever section has its movement taken up by the spring (5) and the joint.

At the inlet into the bottom of the pump barrel, there is an inlet valve (8) and at the outlet, behind the acceleration jet, there is an outlet valve (9). This outlet valve is fitted with a ball which lifts and closes the air hole above during the pump stroke, whereby fuel is sprayed in through the acceleration jet (10). During normal running the ball closes the connection from the air hole to the acceleration jet. In this way fuel is prevented from passing through this jet when the pump is not operating.

CARBURETTOR, STROMBERG

(Engine, type 2)

Type 2 engine is provided with a horizontal carburettor of type Stromberg 175-CD-2 S, which is shown in Figs. 69 and 70. The carburettor is fitted with a single jet, the fuel flow orifice area of which is varied by means of a movable tapered needle. The position of the needle is determined by the carburettor housing vacuum operating an air valve in which the needle is fitted.

The carburettor consists of three main parts of light-alloy, the middle part of which comprises the carburettor housing (the main body). The lower section is made up of a floatchamber, which encloses the jet. The jet is adjustable vertically. The upper section consists of a suction chamber, limited by a diaphragm at the bottom, in which the air valve is fixed. The suction chamber is linked to the inlet channel of the carburettor by means of two channels in the valve.

FLOAT SYSTEM

Fuel flows into the floatchamber via the float valve (4, Fig. 71). The float (1), which is made up of twin expanded rubber floats, is carried on the bridge on the lower side of the carburettor housing. As the fuel level rises, the float lifts and, by means of the float arm (2) and tag, closes the needle on its seating when the correct level has been attained.

The fuel flows through four holes in the jet holder and also four holes in the upper part of the adjusting screws to the inside of the jet, where the level will be the same as that in the floatchamber. The seal of the adjusting screw and the jet holder, between the jet holder and the floatchamber and between the jet and the guide is provided by O-rings (15, 16 and 17, Fig. 73).

COLD START DEVICE AND FAST IDLE

To facilitate starting during cold weather, the carburettor is provided with a cold start device (Figs. 72 and 73).

The cold start device consists of a valve disc (3, Fig. 72) which is provided with four calibrated

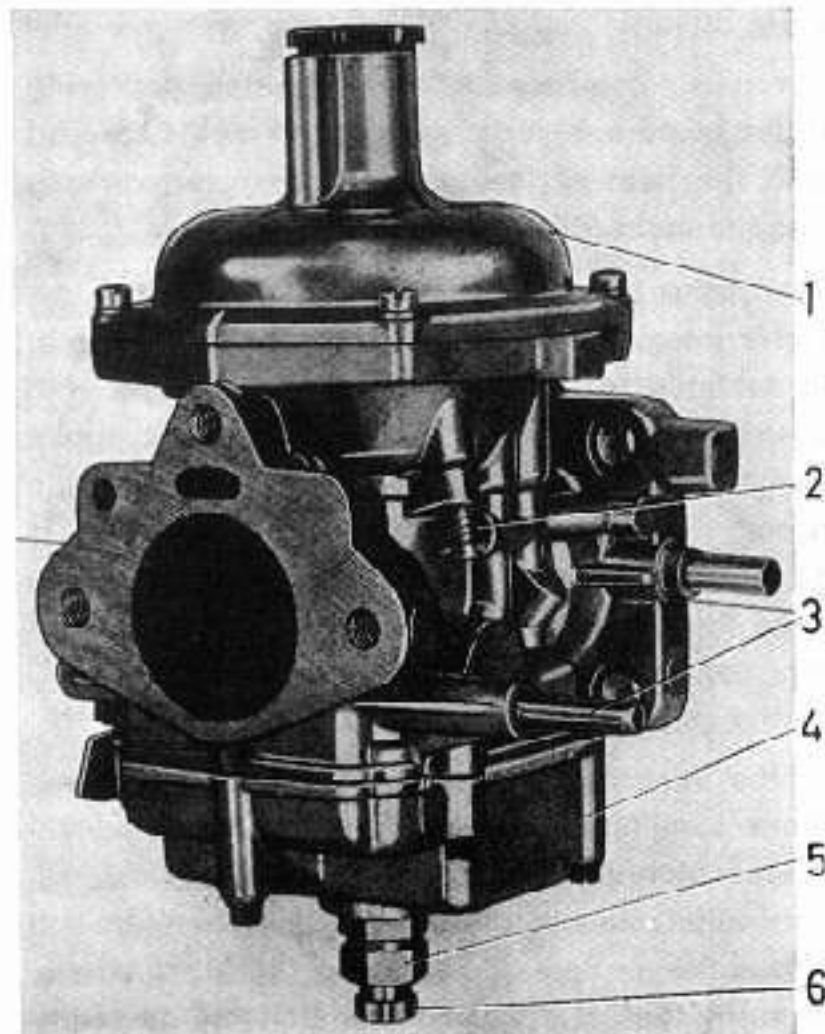

Fig. 69. Carburettor, Stromberg, from the left

- | | |
|--------------------|--------------------|
| 1. Suction chamber | 4. Float housing |
| 2. Pin | 5. Jet holder |
| 3. Fuel inlet | 6. Adjusting screw |

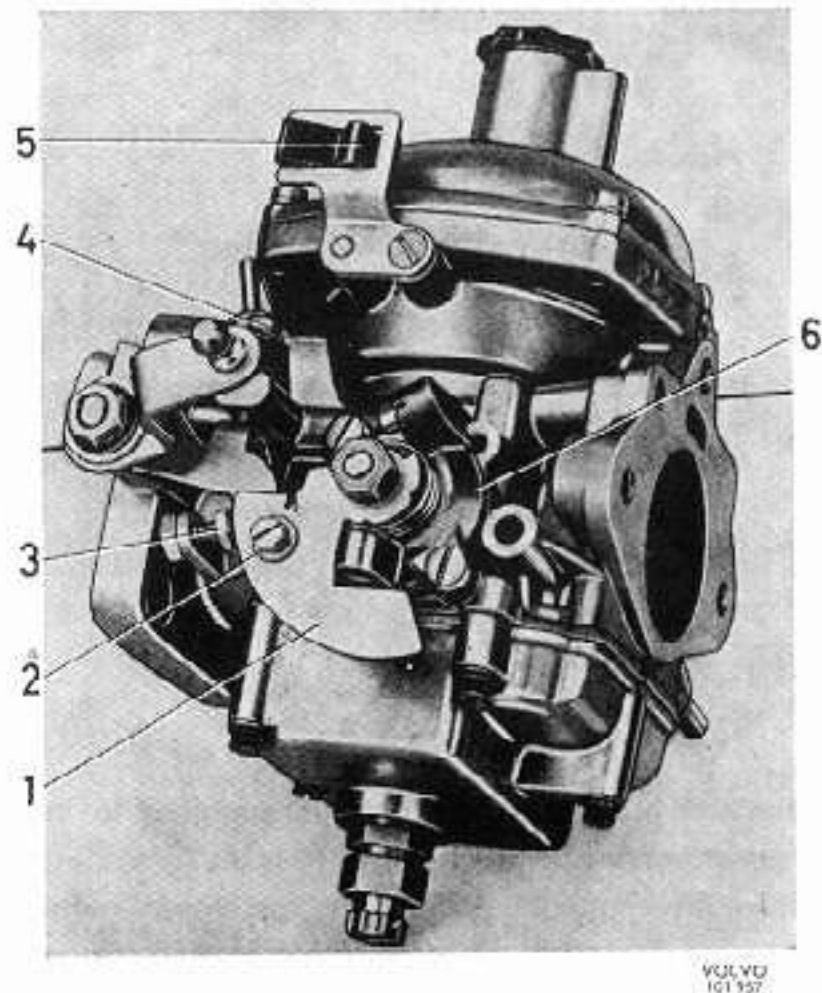

Fig. 70. Carburettor, Stromberg, from the rear

- | | |
|-----------------------------|---------------------------------------|
| 1. Choke cam | 4. Throttle stop screw |
| 2. Choke control connection | 5. Attaching sleeve for choke control |
| 3. Fast-idle stop screw | 6. Cold start device |

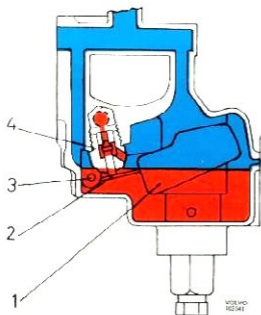

Fig. 71. Float system (Stromberg)

1. Float
2. Float arm
3. Shaft
4. Float valve

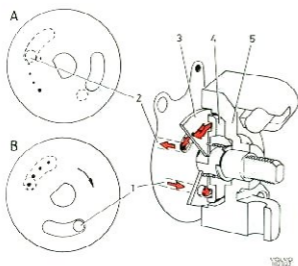

Fig. 72. Cold start device

- A. Cold start device, disengaged
B. Cold start device, engaged

1. From floatchamber
2. To venturi
3. Choke lever
4. "Channel disc"
5. Housing

holes and an elongated opening as well as a disc (4) which is provided with a channel and which is fitted on a shaft operated by the choke control. On the same shaft, outside the cover (5) is a choke cam (1, Fig. 70) located with a connection for the pull wire of the throttle control. When the cold start device is engaged, the valve disc turns and this links up the channel (1, Fig. 72) from the floatchamber via one or several of the calibrated holes to the channel behind the valve disc and then the opening to the channel (2), which terminates in the venturi between the vacuum plunger and the choke flap.

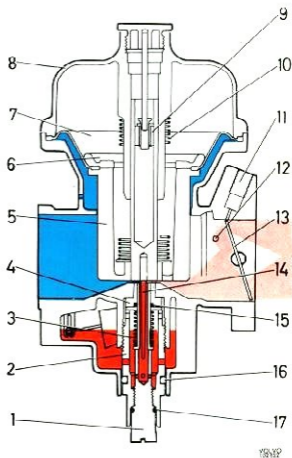

Fig. 73. Cold start, Stromberg

- | | |
|----------------------------|-----------------------------|
| 1. Orifice adjusting screw | 10. Spring screw |
| 2. Jet holder | 11. Vacuum connection |
| 3. Spring | 12. Cold start fuel channel |
| 4. Guide | 13. Throttle flap |
| 5. Air valve | 14. Metering needle |
| 6. Washer | 15. O-ring |
| 7. Diaphragm | 16. O-ring |
| 8. Suction chamber | 17. O-ring |
| 9. Damper piston | |

Through this link-up, the engine receives extra fuel, a richer mixture, to facilitate cold starting. When the throttle control is moved in, this turns the valve disc and shuts off the inlet to the channel. By means of the choke lever, the valve disc is operated simultaneously with the opening of the throttle flap by means of the fast-idle stop screw (3, Fig. 70) and the lever before any of the calibrated holes open the supply from the fuel channel. With this arrangement, the driver can increase if necessary the idling speed while the engine is being warmed up.

IDLING

The carburettor is not provided with a special idling system. When the engine is idling, the vacuum in the induction manifold and the suction chamber of the carburettor is low and the column between the vacuum plunger and the bridge will be small (Fig. 74). At this stage, the thicker section of the metering needle is in the jet and thus only a small quantity of fuel, corresponding to idling requirements, is sucked into the engine.

The fuel-air mixture is adjusted by means of the

orifice adjusting screw (1, Fig. 73) at idling speed and applies to the entire speed range.

NORMAL RUNNING

With the opening of the throttle flap, engine induction manifold depression is transferred via the channels in the plunger (5, Fig. 73) to the suction chamber which is sealed from the main body of the carburettor by the diaphragm. The pressure difference between the underside of the air valve, where there is pressure in the carburettor inlet port and the upper side of the valve, where there is vacuum, causes the valve to lift from the bridge. This also lifts the tapered metering needle (14), which is attached to the plunger, out of the jet. The effective choke area and thus also the fuel flow increases. See Fig. 75.

As the vacuum in the engine induction manifold is dependent upon the engine speed and load, the correct fuel flow is obtained under all operating conditions.

Because of the variable choke area between the bridge and the valve, the air velocity and pressure drop across the jet orifice will always remain approximately constant, thus ensuring good fuel atomization at all speeds.

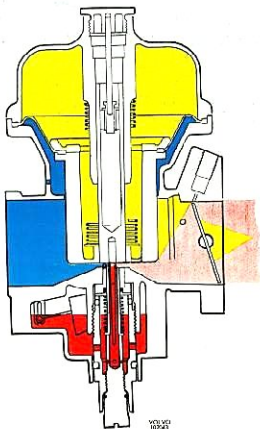

Fig. 74. Idling

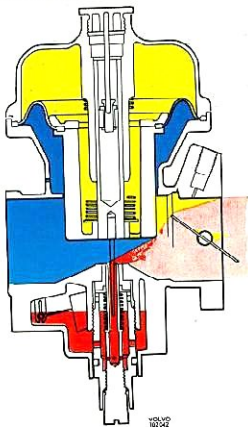

Fig. 75. Normal running

ACCELERATION

To provide at any point in the throttle range a temporary richer mixture at the moment the throttle is suddenly open, a hydraulic damper is arranged inside the valve rod. The hydraulic damper consists of a plunger mounted on a rod. The plunger operates in oil. When the throttle is suddenly opened, the vacuum in the suction chamber increases rapidly.

When the air valve (5, Fig. 73) is lifted up, this forces the damper plunger (9) against its seat and thus prevents oil from flowing past from the upper side to the lower side of the damper plunger and the movement of the valve (5) is resisted. This temporarily results in a more powerful vacuum above the jet so that the fuel-air mixture becomes for the moment richer.

The downward motion of the air valve (5) is assisted by the spring (10). The rod in the valve (5) should be filled to approximately within a 1/4" from the upper edge with the oil approved as "Oil for Automatic Transmissions, Type A".

AIR CLEANER

The air cleaner functions both as a cleaner for the induction air and as an induction silencer. Four different types can be fitted: one with a replaceable paper element, one with a non-replaceable paper element, one of the oil-bath type and one of the foam plastic sleeve type.

The paper element may not be washed or moistened, the only servicing permitted in this connection being to replace either the complete element or the complete air cleaner as the case may be.

Where an oil-bath type air cleaner is fitted, this should be dismantled for servicing and cleaned, after which new oil is filled to the correct level.

Cars intended for markets where driving conditions are particularly dusty have their engines fitted with an air cleaner with a foam plastic sleeve. This increases the air cleaner's capacity to keep out dust (see Fig. 80).

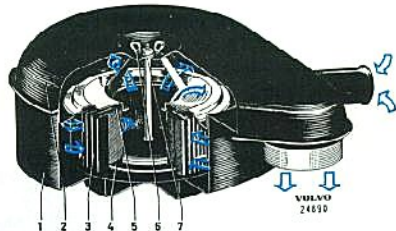

Fig. 76. Air cleaner type with replaceable paper element

- | | |
|------------------|-------------|
| 1. Lower section | 5. Gasket |
| 2. Upper section | 6. Wing nut |
| 3. Element | 7. Washer |
| 4. Gasket | |

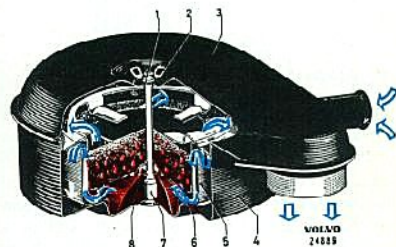

Fig. 77. Air cleaner type II with oil bath

- | | |
|------------------|--------------|
| 1. Washer | 5. Container |
| 2. Wing nut | 6. Element |
| 3. Upper section | 7. Bolt |
| 4. Lower section | 8. Washer |

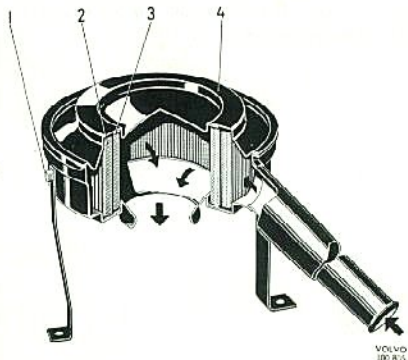

Fig. 78. Air cleaner type III with non-replaceable element

- | | |
|-------------------|-----------|
| 1. Attaching bolt | 3. Gasket |
| 2. Element | 4. Casing |

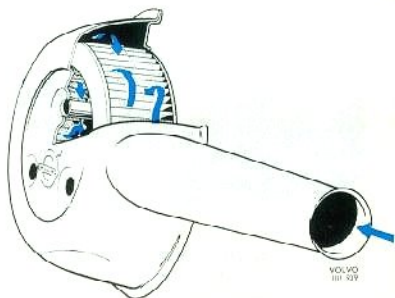

Fig. 79. Air cleaner type IV with non-replaceable element

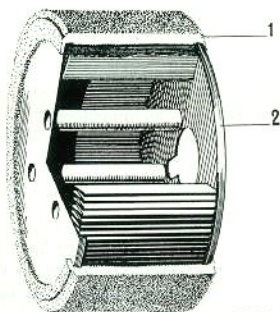

Fig. 80. Air cleaner type V with foam plastic sleeve

1. Foam plastic sleeve 2. Air cleaner

FUEL PUMP

The fuel pump is of the diaphragm type and is driven by a cam on the camshaft. When the rocker arm in the pump is pressed upwards by the cam, the diaphragm is pulled downwards and fuel is drawn up to the pump. When the rocker arm returns, the diaphragm is pressed upwards by a spring (15, Fig. 81) and fuel is fed to the float-chamber in the carburettor. When the lever in the float-chamber is sufficiently high, the float valve closes and the pressure in the delivery line rises until the pressure on the upper side of the diaphragm exceeds the spring pressure and pumping action ceases. The red arrows (Fig. 81) show the path followed by the fuel.

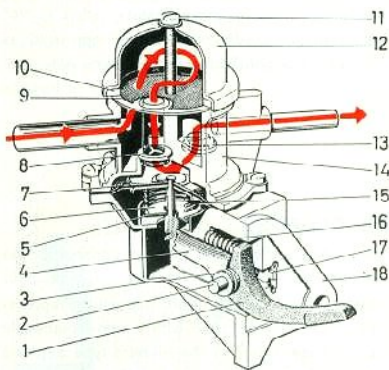

Fig. 81. Fuel pump

- | | |
|----------------|------------------------|
| 1. Rocker arm | 10. Gasket |
| 2. Pin | 11. Bolt with washer |
| 3. Washer | 12. Cover |
| 4. Lever | 13. Outlet valve |
| 5. Rubber seal | 14. Upper pump housing |
| 6. Washer | 15. Diaphragm spring |
| 7. Diaphragm | 16. Return spring |
| 8. Inlet valve | 17. Rider |
| 9. Strainer | 18. Lower pump housing |

REPAIR INSTRUCTIONS

CARBURETTOR, ZENITH

CLEANING THE CARBURETTOR WHEN FITTED ON ENGINE

Before cleaning the carburettor, always make sure that the sludge trap on the fuel pump has been cleaned out.

When cleaning the carburettor it is often sufficient merely to move the floatchamber, take out the float, screw out the air jet for idling (4, Fig. 82) as well as the actual idling jet which is located under the air jet. Also remove the acceleration pump plunger and the idle fuel screw, this screw being on the carburettor housing. Remove the needle valve and check or clean it. Wash the parts concerned in white spirit or alcohol. Blow through all channels and jets with compressed air, including the hole for the idle fuel screw.

Check that the jets screwed out are clean by holding them up against the light.

Fit the parts, start the engine and adjust idling speed.

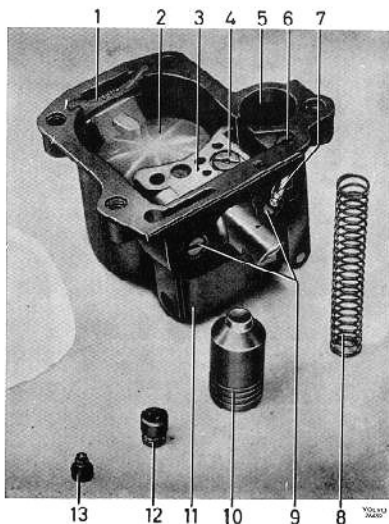

Fig. 82. Float chamber

1. Lock spring
(Marked TOP)
2. Float
3. Emulsion block
4. Air jet for idling
5. Barrel
6. Outlet valve
7. Acceleration jet
8. Spring
9. Screws
10. Plunger
11. Floatchamber
12. Inlet valve
13. Stop screw

REMOVING

1. Blow the carburettor clean externally. Remove the upper part of the air cleaner. Disconnect the fuel line and vacuum hose.
2. Disconnect the throttle and choke controls on the carburettor.
3. Screw off the attaching nut and lift up the carburettor. Cover the hole in the intake manifold with masking tape.

DISMANTLING

1. Remove the floatchamber by screwing out its attaching screws.
2. Remove the lock spring (1, Fig. 82) and lift up the float (2). Note the marking "TOP" on the lock spring.
3. Remove the emulsion block screws (9) and take out the block.

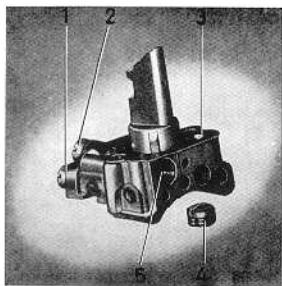

Fig. 83. Emulsion block

- | | |
|---------------------------------|-----------------------|
| 1. Compensation jet | 4. Air jet for idling |
| 2. Main jet | 5. Idling jet |
| 3. Air jet for partial throttle | |

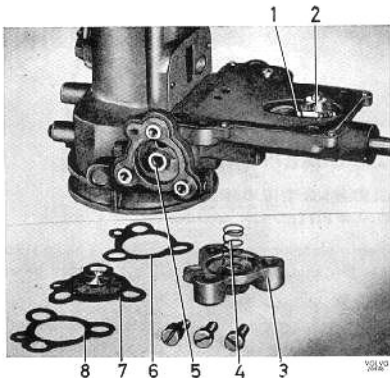

Fig. 84. Economizer valve

- | | |
|----------------|------------------------|
| 1. Washer | 5. Seat |
| 2. Float valve | 6. Gasket |
| 3. Cover | 7. Diaphragm with disc |
| 4. Spring | 8. Gasket |

- Screw out all the jets from the emulsion block, see Fig. 83.
- Remove the acceleration pump plunger, spring, inlet valve, outlet valve and acceleration jet. See Fig. 82.
- Remove the float valve and the economizer valve, Fig. 84. Screw out the idle fuel jet.
- Clean all parts in white spirit or alcohol. Blow out all channels and jets with compressed air.

Never clean jets with wire or a drill; this ruins them and they must then be replaced.

ASSEMBLING

Assembling is carried out in the reverse order to dismantling.

- Check that all parts are in good condition and clean. Fit new washers and gaskets.
- Check that the economizer valve disc (7, Fig. 84) is in good contact with its seat (5). The disc can be lapped in against the seat with fine grinding compound if necessary.
- Fit the lock spring for the float with the "TOP" marking facing upwards. The spring under the pump plunger is pushed down so that it goes into the inlet valve in the bottom of the barrel. Check that the washer for the float has the correct thickness according to the "Specifications". It is not possible to adjust the level.
- When the float bowl is fitted it should be pressed inwards and upwards when tightening the screws.

The emulsion block nozzle (5, Fig. 85) should be in contact with the stay across the venturi. If not, loosen the venturi screw and adjust its position.

ACCELERATION PUMP STROKE

The pump plunger can be adjusted to a short or long stroke by means of the washer (6, Fig. 85). To alter the stroke length, lift the washer and turn it half a turn. The short stroke is the normal adjustment, in other words, the highest cam lobe on the cam washer faces the spring on the lever.

FITTING

Clean the face on the intake manifold and the carburettor. Check to make sure that the surface is not warped or damaged. Fit on a new gasket and fit the parts in the reverse order to removal.

ADJUSTING THE FAST IDLE

Pull out the choke control fully and check that the front cam on the choke lever stops against the check.

Screw out the fast idle adjuster screw (9, Fig. 85) so that it comes flush with the underside of its bracket. Then screw down the screw three and a half turns. Push in the choke control.

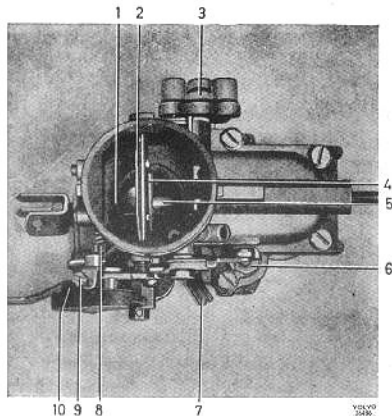

Fig. 85. Position of venturi

- | | |
|--------------------------|------------------------------|
| 1. Venturi | 6. Washer |
| 2. Choke flap | 7. Idle fuel screw |
| 3. Economizer valve | 8. Idle adjusting screw |
| 4. Stay | 9. Fast idle adjusting screw |
| 5. Emulsion block nozzle | 10. Idling cam |

ADJUSTING THE IDLING

The adjustment is carried out with a warm engine.

1. Adjust the idling speed to 500–700 r.p.m. by using the screw (8, Fig. 85) on the throttle flap lever.
2. Adjust the fuel/air mixture with the idle screw (7). First screw inwards (leaner mixture) until the engine begins to run roughly and then slowly outwards until the engine runs evenly.
3. Adjust engine speed if necessary by means of the screw on the throttle flap lever.

ADJUSTING THE ACCELERATION PEDAL

There should be a clearance of 1 mm (0.040") between the lever on the throttle flap and the full throttle stop when the accelerator pedal is fully depressed.

Adjustment is carried out by altering the length of the vertical push rod.

When the accelerator pedal is fully depressed, the force exerted by the foot of the driver will thus be taken up against the floorboard without exerting unnecessary loading on the throttle control system.

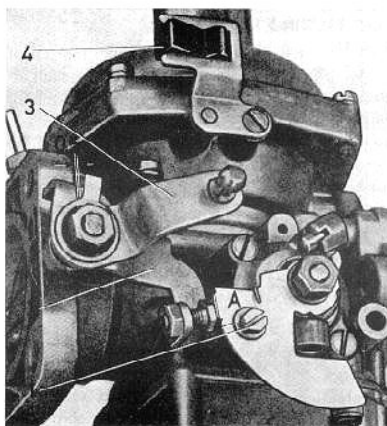

Fig. 86. Setting the fast idle

- | | |
|------------------------------|----------|
| 1. Clamp screw for pull wire | 3. Lever |
| 2. Inner lever | 4. Clip |

CARBURETTOR, 'STROMBERG

SETTING THE IDLE AND FAST IDLE

Two adjustments are employed when regulating the idle speed and mixture.

1. Remove the air cleaner and press down the air valve (5, Fig. 73) against the bridge. Screw the adjusting screw (1) until the jet touches the valve. Then unscrew the adjusting screw 1 1/2 turns. For the basic adjustment of the idling speed the screw should be screwed in about 2 1/2 turns.
2. Run the engine until it is warm.
3. Adjust the stop screw until an idle speed of about 600–650 r.p.m. is obtained.
4. Turn the orifice adjusting screw (1) downwards until the engine starts to run unevenly. Then turn the screw in the opposite direction until the engine once again starts to run unevenly, and note the speed. Finally turn the screw back to a point somewhere between these positions.
5. Adjust the fast idle adjusting screw until it merely touches the choke cam at a point 11–13 mm = 1/2" (A, Fig. 86) from the upper part when choke cam is turned upwards.
(In extremely cold weather, adjust the screw so that it just touches the choke cam when the choke control is pushed in fully.)

CENTRALIZING THE JET

1. Screw up the orifice adjuster until the top of the orifice is just above the bridge. Slacken off the whole jet assembly (8, Fig. 89) a couple of turns.
2. If the carburettor is removed, it should be placed with the flange on the throttle flap side downwards. Tighten the jet assembly slowly, checking frequently that the needle remains free in the orifice. Check by raising the air valve approximately 1/4" and allowing it to fall freely so that the spring presses against the bridge. (The piston can be pressed against the bridge with the help of the fingers.)
3. When the jet assembly has been tightened, check the centralizing again by lifting and releasing the valve with the help of the pin (2, Fig. 69). If a clear sound is not heard when the valve strikes against the bridge, then repeat the centring procedure.

FLOAT LEVEL

To check the float level, remove the carburettor, invert it and then remove the floatchamber.

At the correct float level, the highest point on the float should lie 15–17 mm (5/8") and the rear edge 4–8 mm (1/4") above the face of the main body (see Fig. 87), when the needle is against its seating.

If the float level is faulty, it can be re-set by carefully bending the tag which contacts the end of the needle.

N.B. Do not bend the float arm.

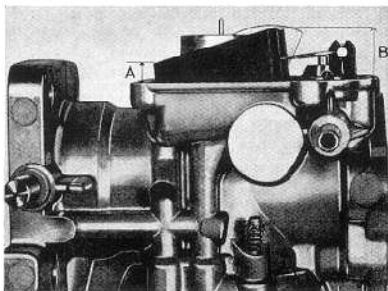

Fig. 87. Float level, Stromberg carburettor

A = 4–8 mm (1/4") B = 15–17 mm (5/8")

The floatchamber is fitted according to the chapter headed, "Assembling the carburettor".

REMOVING THE CARBURETTOR

Disconnect the fuel pipe, accelerator control, air cleaner, choke control and the vacuum line to the distributor. Slacken the nuts and remove the carburettor.

DISMANTLING THE CARBURETTOR

1. Make aligning marks on the suction chamber and the main body. Remove the suction chamber (2, Fig. 88) and the spring (1).
2. Remove the piston (8) with the diaphragm (7).
3. Slacken the screw (9) and remove the metering needle (10).
4. Remove the screws (5), the washer (6) and the diaphragm (7).

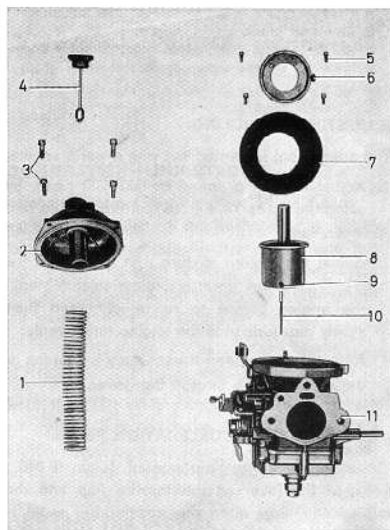

Fig. 88. Upper section dismantled

- | | |
|--------------------|-----------------------------------|
| 1. Spring | 7. Diaphragm |
| 2. Suction chamber | 8. Air valve |
| 3. Screw | 9. Locking screw, metering needle |
| 4. Damper piston | 10. Metering needle |
| 5. Screw | 11. Intermediate section |
| 6. Washer | |

5. Remove the floatchamber (1, Fig. 89).
6. Carefully break off the float shaft from the bridge and remove the float.
7. Unscrew and remove the jet holder (8) together with the adjusting screw (10), the jet (7), the spring (6), the guide (4) and the washers (3 and 5).
8. Remove the fuel inlet needle and the washer.
9. Remove the cold start device.

CLEANING

Wash the carburettor components clean with paraffin (kerosene) or petrol. N.B. The diaphragm must only be cleaned in paraffin (kerosene).

Avoid using cleaning agents such as trichloroethylene. Blow the holes clean in the valve disc of the cold start device with compressed air.

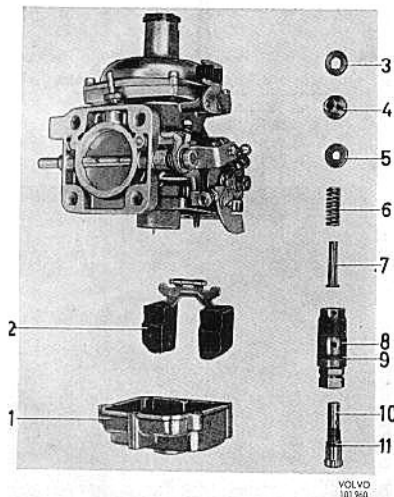

Fig. 89. Floatchamber dismantled

- | | |
|----------------------|---------------------|
| 1. Floatchamber | 7. Jet |
| 2. Float | 8. Holder |
| 3. Washer | 9. O-ring |
| 4. Guide with O-ring | 10. Adjusting screw |
| 5. Washer | 11. O-ring |
| 6. Spring | |

INSPECTION

Check that diaphragm is not damaged. If it is cracked or distorted, replace it. Check the metering needle for wear. If it is bent or worn, replace it. Check that the contact and sealing surfaces are not damaged. Check the valve disc (Fig. 90) on the cold start device and the corresponding sealing surface of the main carburettor body for scratches.

ASSEMBLING THE CARBURETTOR

1. Place the diaphragm (7, Fig. 88) on the air valve (8), so that the projection (Fig. 91) fits into the corresponding recess in the valve and its guiding edge fits easily into the corresponding slit in the air valve.

N.B. If the diaphragm is distorted so that it cannot fit into the slit, replace the diaphragm. Carefully place the washer (6, Fig. 88) so that the screw holes coincide with the corresponding holes in the air valve and diaphragm without the need for turning the washer, and the washer groove mates with the guide edge of the diaphragm. Tighten down the washer (6) with the screws (5).

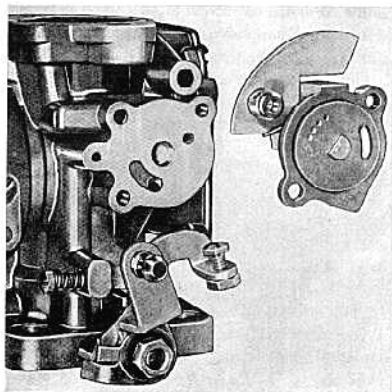

Fig. 90. Cold start device

- Fit the metering needle (10), see Fig. 92. The cylindrical section of the needle should be flush against the valve.
- Fit the valve with the diaphragm into the main carburettor body. Make sure that the tag fits into the corresponding recess in the body (see Fig. 93) (distorted diaphragm, see above). Carefully fit on the suction chamber according to the alignment marks. The slit and guiding edge should fit easily, otherwise the chamber should be replaced. Screw it down.
- Screw in the adjusting screw (10, Fig. 89) together with a new O-ring (11) into the jet holder (8). Fit a new O-ring (9) on the jet holder.
- Fit the spring (6), the brass washer (5), the guide (4) with a new O-ring and light-alloy washer (3) on the jet, and fit the entire assembly together with the jet holder and adjusting screw into the main carburettor body. Screw in the jet holder by hand but do not tighten it. Screw in the adjusting screw until the upper part of the jet lies against the air valve when the latter is at its lowest position. Centre the jet and the guide according to the instructions given in "Centralizing the jet" on page 46.
- Fit the float (2) with shaft. The flat side of the float should be facing away from the main carburettor body.
- Check the float level, read through "Flat Level" on page 46.
- Fit a new gasket onto the floatchamber and move the chamber until contact is made with the O-ring. First screw in all screws a couple of turns. Then move the floatchamber down to

the contact surface of the upper section and tighten the screws.

- Fit the cold start device. (If the cold start device was disassembled, fit the valve and cam discs according to Fig. The calibrated holes should face the cam disc.)

ADJUSTING THE THROTTLE CONTROL

After setting the idling speed, adjust the length of the pull rod (in the right-hand and left-hand position respectively in the ball caps) so that there is a clearance of 0.5 (0.02") between the throttle lever and the flange arms of the inner lever. See Fig. 86.

ADJUSTING THE CHOKE CONTROL

Make sure that the choke control on the instrument panel is pulled in fully. Then lock the pull wire in

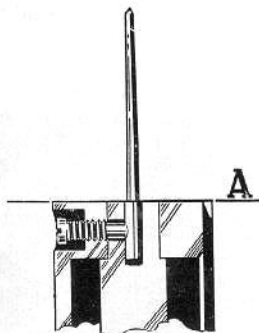

Fig. 92. Fitting the metering needle

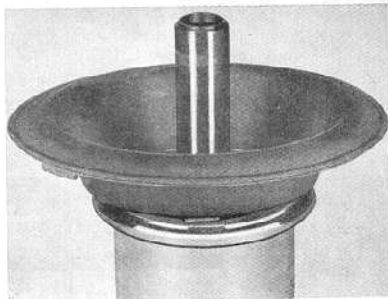

Fig. 91. Diaphragm and air valve

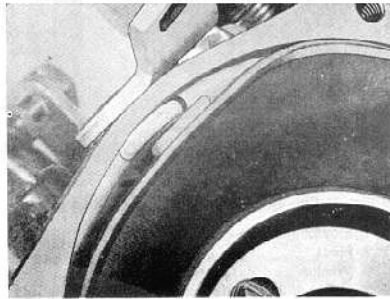
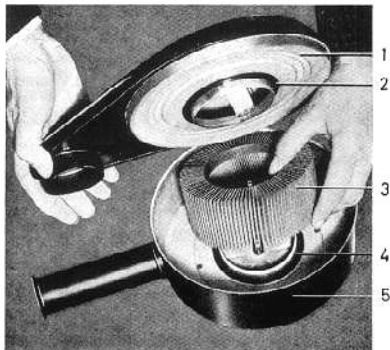

Fig. 93. Diaphragm fitted in carburettor body



VOLVO
26500

Fig. 94. Air cleaner, replacing element, type I

1. Upper section
2. Gasket
3. Element
4. Gasket
5. Lower section

the fast idle cam clamp screw (1, Fig. 86). After this, fasten the outer sleeve of the pull wire the clips intended for this purpose.

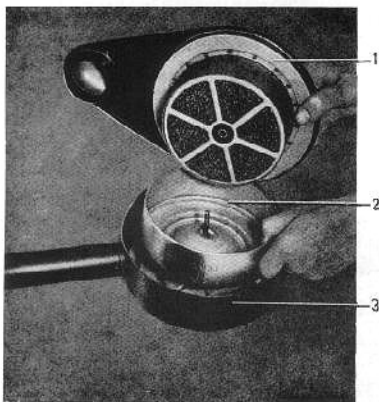

VOLVO
26001

Fig. 95. Oil-bath air cleaner, cleaning, type II

1. Upper section
2. Container
3. Lower section

AIR CLEANER

Air cleaner, type I with replaceable element

The element should be replaced with a new one every 20 000 km (12 500 miles) if the vehicle is driven in districts with moderate air contamination. When driving in very dusty areas it may be necessary to carry out replacement at shorter intervals.

No cleaning of any sort may be carried out between changes. On no account must the element be moistened or oiled.

A sign of a blocked air cleaner is increased fuel consumption.

REPLACING THE ELEMENT

1. Loosen the upper hose clamp and remove the wing nut.
2. Lift off the upper section and remove the old element (3, Fig. 94).
3. Wipe carefully clean from dust and dirt inside the lower part of the cleaner by using a damp cloth. Also clean off the upper part of the air cleaner. Check that the gaskets (2 and 4) are in good condition, otherwise replace them.
4. Take up the new element, shape it and fit it. Then fit the upper section.

Air cleaner, type II (oil-bath)

This air cleaner should normally be dismantled and cleaned every 10 000 km (6 000 miles). When driving in particularly dusty areas, however, it may be necessary to carry out cleaning more frequently. If the fuel consumption increases, this may be due to a blocked air cleaner.

CLEANING THE AIR CLEANER AND CHANGING THE OIL

1. Loosen the upper hose clip and wing nut. Lift off the upper section (1, Fig. 95).
2. Lift up the inner container (2) and empty out the old oil. Wash the container in white spirit. Also wash the element and clean the other parts.
3. Lay the container in the lower section. Fill the container with oil up to the level mark. N.B. Only add oil to the container itself, not to the actual lower section. Use the same type of oil as in the engine.
4. Fit the upper section on the cleaner.

Air cleaner, type III, with non-replaceable elements

The element is not replaceable but every 40 000 km (25 000 miles) the complete air cleaner should be replaced. When driving in very dusty areas, replacing should be done more frequently. No cleaning of any sort is permitted between the replacement intervals. **On no account must the element be moistened or oiled.**

REPLACING AIR CLEANER, TYPES III AND IV

Remove the air cleaner and discard it. Check the gasket on the carburettor and fit a new air cleaner.

Air cleaner with foam plastic sleeve, type V

CHANGING INTERVALS

Abnormal fuel consumption or weak engine may be signs that the air cleaner is blocked. If this is the case, change the foam plastic sleeve and also the paper filter, irrespective of the distance driven.

Normally a foam plastic sleeve can be washed or changed three times, after which occasion the paper filter must also be changed. In certain special cases, the paper filter can also be cleaned (not, however, washed).

CLEANING THE PLASTIC SLEEVE

Remove the foam plastic sleeve and shake out loose particles. Place the sleeve in a bath containing one of the following solutions:

- Warm soapy water.
- Warm water with a washing agent (dish-washing) with no or low sud content.
- Kerosene (paraffin).
- Fuel oil.



Fig. 96. Air cleaner, type III, with non-replaceable element



Fig. 97. Air cleaner, type IV

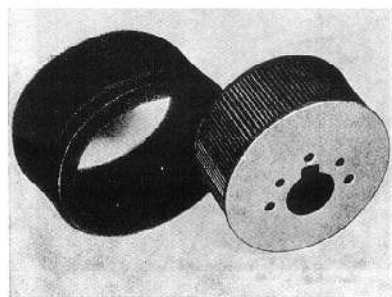

Fig. 98. Air cleaner with foam plastic sleeve, type V

Squeeze the sleeve in the solution until it is clean, then rinse it in clean water and dry it, but not under direct heat.

CLEANING THE PAPER FILTER

Knock the flat top and bottom sides of the filter against a flat base. Make sure that the paper folds are not damaged.

OILING THE FOAM PLASTIC SLEEVE

Before refilling the foam plastic sleeve, immerse it in 15 cm³ of oil (SAE 30). Then squeeze the sleeve in the oil until the oil is spread over the entire sleeve. Any surplus oil can be removed by rolling the sleeve in a clean cloth.

FITTING THE FOAM PLASTIC SLEEVE

The foam plastic sleeve is fitted in such a way over the paper filter that the paper folds are not touched by the sleeve. The chamfered edges of the sleeve should lie over the filter edges round the whole circumference.

FUEL PUMP

CLEANING THE STRAINER

Release the retaining clip and remove the glass, type I. On types II and III the cover is removed. Take out the strainer and blow it clean. Check before fitting the glass or cover that the gasket is in good condition and seals properly. Replace it with a new one if necessary.

CHECKING THE CONDITION OF THE FUEL PUMP

Before removing the fuel pump its condition should be checked with a fuel pressure gauge. Connect a pressure gauge and run the engine until the pressure does not rise any more. Stop the engine, check the pressure and compare the value with that given in the "Specifications". Also check the pressure-drop after the engine has been stopped. If the pressure falls, this indicates leaking valves or a leaking float valve.

REMOVING

Disconnect the fuel line connections and remove the pump.

DISMANTLING, TYPE I

1. Separate the upper and lower parts of the pump.
2. Remove the diaphragm by pressing it down and turning it a quarter of a turn.
3. Remove one circlip for the rocker arm (8, Fig. 99) shaft (9). Press out the shaft. Remove the rocker arm, spring, link arm (7) and washers.
- 4a. Replacing valves (earlier attaching arrangement), Fig. 100.

Unscrew the screws for the retainer. Remove the old valves. Clean the valve recesses. Place the new seals and the new valves in position and fit the retainer.

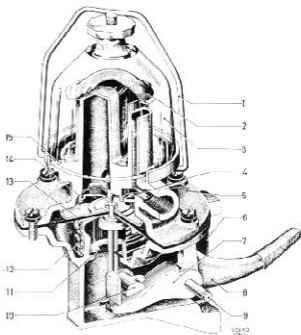

Fig. 99. Fuel pump, type I

- | | |
|-----------------------|------------------|
| 1. Retaining clamp | 9. Shaft |
| 2. Strainer | 10. Stop |
| 3. Sludge trap | 11. Seal |
| 4. Inlet valve | 12. Spring |
| 5. Upper pump housing | 13. Diaphragm |
| 6. Lower pump housing | 14. Outlet valve |
| 7. Link arm | 15. Gasket |
| 8. Rocker arm | |

- 4b. Replacing valves (later attaching arrangement), Fig. 101.

Remove the old valves with a screwdriver or other suitable tool. Clean the valve recesses. Place the new seals and valves in position. Press down the new valves into their correct position with the help of a sleeve. A piece of tubing as shown in Fig. 100 can be used. Then peen over the material round each valve in four places with a punch, see Fig. 101. The type of punch is shown in Fig. 100.

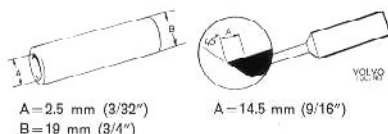

Fig. 100. Tools for fitting valves in fuel pump

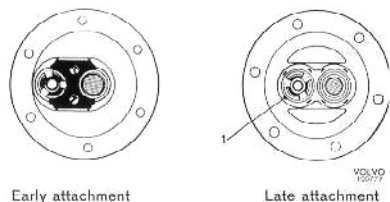

Fig. 101. Fitting valves in fuel pump

1=Peening

ASSEMBLING, TYPE I

1. Fit the link arm, washers, spring and rocker arm. Press in the shaft. Fit the circlips.
2. Fit the new valves and (early production) retainer. On late production, fit the new valves and peen over with a punch as shown in Figs. 100 and 101.
3. Fit the new diaphragm by pressing down the rod in position and turning it a quarter of a turn.
4. Assemble the upper and lower parts.
5. Fit the glass and retaining clamp. Make sure that the gasket seals properly. After assembling, test the pump. When fitting, make sure that the lever comes in the correct position above its cam.

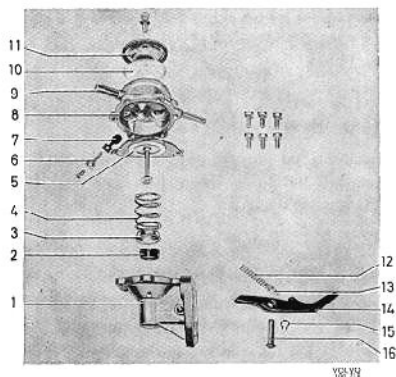

Fig. 102. Fuel pump, type II

1. Lower pump housing
2. Rubber seal
3. Guide
4. Diaphragm spring
5. Diaphragm
6. Stop arm
7. Spring
8. Upper pump housing
9. Inlet pipe
10. Strainer
11. Cover with gasket
12. Return spring
13. Spring retainer
14. Lever
15. Circlip
16. Lever pin

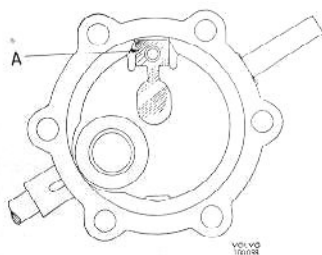

Fig. 103. Spring location

A. Recess

DISMANTLING, TYPE II

1. Make line-up marks on the upper part and lower part. Separate the upper part from the lower part.
2. Remove one circlip (15, Fig. 102) from the lever pin (16). Press out the pin. Pull out the lever and spring (14) and (12).
3. Remove the diaphragm (5) with spring, guide (3) and rubber seal (2). The spring can be removed after the rubber seal has been pulled up over the nylon washer.
4. Unscrew the screw on the underside of the upper part, remove the stop arm (6) and spring valve (7). The inlet valve cannot be removed.

INSPECTING

Check the diaphragm and gasket for leakage and the moving parts for wear. Replace any damaged or worn parts.

ASSEMBLING, TYPE II

1. Fit the leaf spring as shown in Fig. 103 and the stop arm. Tighten the screw but no harder than

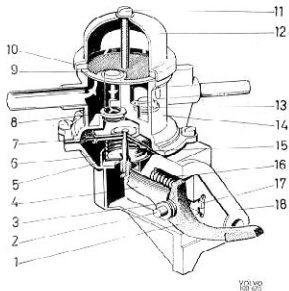

Fig. 104. Fuel pump, type III

- | | |
|----------------|------------------------|
| 1. Rocker arm | 10. Gasket |
| 2. Pin | 11. Screw with washer |
| 3. Washer | 12. Cover |
| 4. Lever | 13. Outlet valve |
| 5. Rubber seal | 14. Upper pump housing |
| 6. Washer | 15. Diaphragm spring |
| 7. Diaphragm | 16. Return spring |
| 8. Inlet valve | 17. Rider |
| 9. Strainer | 18. Lower pump housing |

so that the leaf spring contacts the pump housing properly.

2. Fit the spring (4) and guide (3), and pull on the rubber seal (2) with the flange inwards facing the guide.
3. Fit the diaphragm unit in the lower part of the pump. Press downwards so that the rubber seal comes into its correct position.
4. Press down the diaphragm, push in the lever (14) and make sure that it comes correctly in relation to the diaphragm rod. Fit the pin (16), circlips (15), spring retainer (13) and spring (12).
5. Fit the upper part in accordance with the line-up marks and tighten it.

Fit the strainer and cover.

Test the pump. When fitting, make sure that the lever comes into its correct position above the cam.

DISMANTLING, TYPE III

1. Remove the cover.
2. Make line-up marks on the upper and lower parts of the pump and separate them.
3. Remove the diaphragm by turning it a quarter of a turn.
4. Remove the spring (15, Fig. 104) by turning the washer (6) so that the hole in it coincides with the wide end of the diaphragm rod.
5. Remove the peening for the rocker arm pin rider (17) with, for example, a grinding rod, and remove the rocker arm (1) with pin (2) and lever (4).
6. Pull out the rocker arm pin. Check the parts for wear.

ASSEMBLING FUEL PUMP, TYPE III

1. Assemble the link arm, rocker arm with washers (3) and rocker arm pin.
2. Insert the linkage system with return spring (16) into the housing.
3. Fit and lock the riders in the housing by peening with a suitable punch, see Fig. 104.
4. Assemble the diaphragm, spring and washers. Place the unit in position and put together the upper and lower parts. Fit the cover.

COOLING SYSTEM DESCRIPTION

GENERAL

Type 1 engine is fitted with a pressurized cooling system, see Fig. 105, while type 2 engine has "sealed" cooling system, see Fig. 106.

The following description applies to both systems with the exception that type 2 engine with the "sealed" cooling system has a separate expansion tank.

A centrifugal pump, see Fig. 107, takes care of the coolant circulation, a double-acting thermostat provides rapid warming of the engine and ensures that the engine has the most suitable temperature irrespective of the operating conditions.

If the sealed cooling system is to operate effectively, it must be well filled and sealed. As coolant, a mixture is used all the year round consisting of 50 % ethylene glycol, Volvo part No. 297176, and 50 % water. This mixture provides anti-freeze protection to a temperature of -35°C (-31°F) and should be changed every other year, on which occasion the engine, radiator, and expansion tank should all be flushed with clean water.

COOLING SYSTEM INNER CIRCUIT (BY-PASS)

When the engine is warming up and in very cold weather when large quantities of heat are required for warming up the inside of the car, the coolant circulates almost exclusively through the inner circuit (the by pass). This circuit covers the engine and car heater. The thermostat is closed, that is the outlet to the radiator is shut off. The coolant passes through the thermostat by-pass to the distributing pipe (3, Fig. 108) in the cylinder head and results in a uniform cooling of the warmest parts in the cylinder head. The parts around the sparking plugs are also cooled and thereby maintained at a constant temperature. The coolant surrounding the cylinder walls is circulated by means of thermo-siphon action.

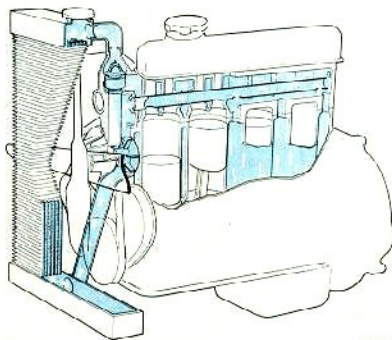

Fig. 105. Cooling system, pressurized type

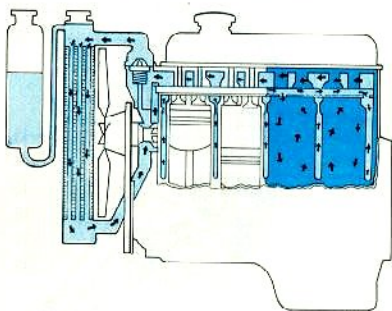

Fig. 106. Sealed cooling system

COOLING SYSTEM OUTER CIRCUIT

When the coolant in the inner circuit reaches a suitable temperature for the engine, the thermostat begins to open during which time the by-pass between the thermostat housing and the pump is gradually closed, see Fig. 109.

The coolant flows from the engine into the upper part of the radiator, is cooled and sucked by the pump out from the lower part of the radiator and

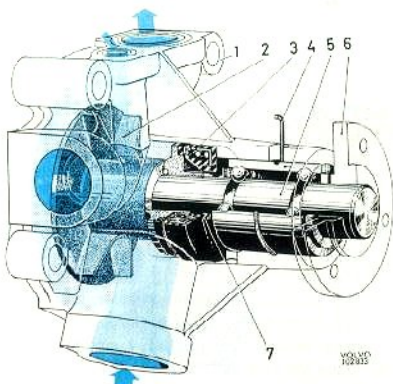

Fig. 107. Water pump

- | | |
|----------------|---|
| 1. Housing | 5. Shaft with ball bearings (integral unit) |
| 2. Impeller | 6. Hub |
| 3. Seal ring | 7. Wear ring |
| 4. Lock spring | |

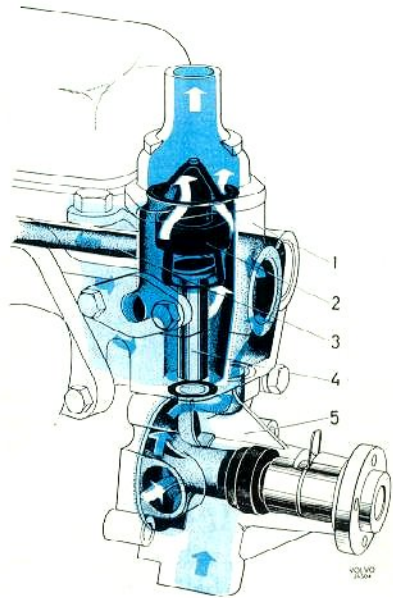

Fig. 109. Coolant flow, thermostat open

- | | |
|----------------------|-----------------|
| 1. Cylinder head | 4. By-pass pipe |
| 2. Thermostat | 5. Water pump |
| 3. Distributing pipe | |

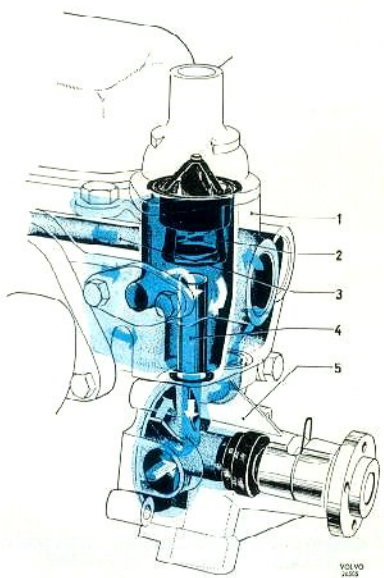

Fig. 108. Coolant flow, thermostat closed

- | | |
|----------------------|-----------------|
| 1. Cylinder head | 4. By-pass pipe |
| 2. Thermostat | 5. Water pump |
| 3. Distributing pipe | |

then pumped into the engine through the distributing pipe.

An air cushion forms in the upper part of the expansion tank and permits the coolant to expand without involving any loss of coolant so that there is air suction at reduced temperature and volume. This arrangement ensures that the cooling system is always filled with coolant, thus minimizing the risk of corrosion.

When the cooling system is being topped up, it will probably be difficult to prevent air from entering the system. The air, however, is subsequently separated and forced out into the expansion tank and is replaced by coolant from this tank.

The cover of the expansion tank is provided with a valve which opens when the pressure in the system reaches 0.3 atmospheric gauge. There is also a valve which opens when there is partial vacuum in the system and admits air into the expansion tank.

REPAIR INSTRUCTIONS

TOPPING UP WITH COOLANT

Topping up with coolant, consisting of 50% anti-freeze and 50% water, takes place in the expansion tank when its level has dropped down to the "Min" mark. N.B. Never top up with water alone.

DRAINING THE COOLING SYSTEM

To drain the cooling system, open a cock located on the engine and remove the plug on the bottom of the radiator. The expansion tank is emptied by first removing it and holding it at a sufficient height so that the coolant runs into the radiator. Another way to empty the expansion tank would be to turn it upside down. When installing, press down the tank well, making sure that it is secure. Make certain that the hose is tightened as shown in Fig. 110.

FILLING EMPTY SYSTEM WITH COOLANT

Before filling, flush the cooling system with clean water. When filling with coolant, through the filler opening on top of the radiator, the heater control should be set at max. heat. Fill also the expansion tank to the "Max" mark or to max. 30 mm (1 1/8") above this mark. Run the engine for several minutes at different speeds. If necessary, top up with more coolant and then fit the expansion tank cap. After driving for a short time, check the coolant level and top up with more coolant as it takes some time before the system is completely devoid of air.

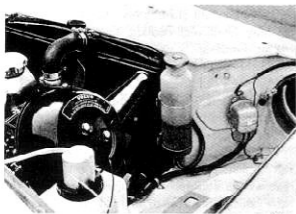

Fig. 110. Expansion tank. Note how the hose is fitted

REPLACING THE RADIATOR

1. Remove the caps and the plug at the bottom of the radiator and drain off the coolant.
2. Remove the expansion tank with hose and empty out the coolant.
3. Slacken the hose clamps for the lower and upper radiator hoses. Remove the upper radiator hose.
4. Remove the bolts for the radiator. Lift off the radiator and disconnect at the same time the lower radiator hose from the radiator.
5. Place the new radiator in position and tighten the bolts.
6. Fit the radiator hoses.
7. Fit the expansion tank with hose. Fit the hose from the radiator **in front of** the expansion tank and down to its underside so that the hose does not come into contact with the fan. See fig. 110. Make sure that the hose has a smooth curve without any sharp folds.
8. Fill with coolant according to the instructions given under "Filling the empty cooling system with coolant".
9. Start the engine and check for leakage.

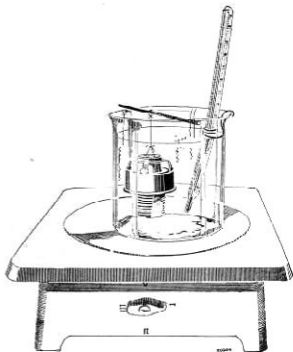

Fig. 111. Testing the thermostat

THERMOSTAT

After being removed, the thermostat can be tested in a vessel containing heated water, see Fig. 111. The thermostat should open and close according to the values given in "Specifications". A faulty thermostat should be discarded. Use a new gasket when fitting the thermostat.

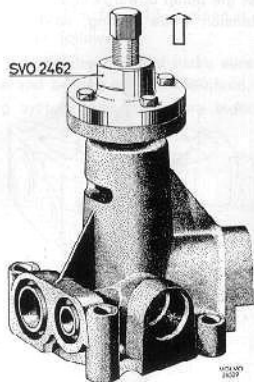

Fig. 112. Removing the hub

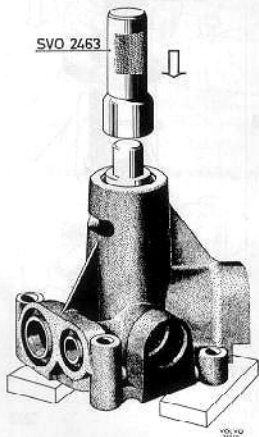

Fig. 113. Removing the shaft and impeller

WATER PUMP

DISMANTLING AND CHECKING

1. Pull out the lock spring.
2. Firmly fit puller SVO 2462 on the hub with the bolts for the pulley and pull off the hub. See Fig. 112.
3. Place the pump in a press. Fit drift SVO 2463 on the outer ring of the bearing and press out the shaft, the bearing and the impeller. See Fig. 113.
4. Inspect the impeller and bearing. If the bearing is worn and has too much play or if it seizes, scrap the shaft and bearing. (The bearing and shaft cannot be dismantled.) If the bearing is usable, it should not be heated or washed in fluid as this would destroy its lubricant protection. If the impeller is removed, it should be replaced with a new one as its removal always results in it being damaged and also having reduced effect. Always replace the seal ring with a new one.
5. As the shaft and impeller must be separated, press the seal ring down and slide in press tool SVO 2492 under the impeller. Then press out the shaft with drift SVO 2266.

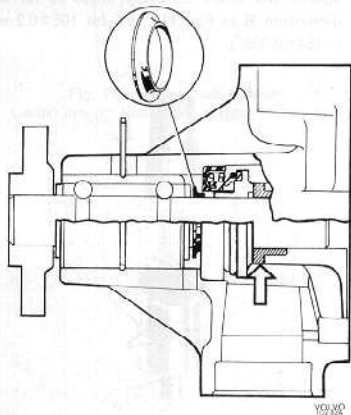

Fig. 114. Location of the oilslinger

ASSEMBLING

Before assembling, check carefully that the parts are not damaged. The sealing surface of the impeller must be even and free from scratches. The bearing should run easily without seizing and may not be loose. Replace damaged parts with new ones.

1. Press down the shaft bearing into the housing with drift SVO 2463 in the same way as shown in Fig. 113 and far enough so that the lock wire can be inserted in its groove. Insert the lock wire.
2. Fit the oilslinger, see Fig. 114 for its location. Fit the seal ring with drift SVO 2430, see Fig. 115. Coat the contact surface of the carbon washer against the impeller with molybdenum disulphide mixed in mineral oil SAE 30. The molybdenum disulphide should be completely dry before the washer is fitted.
3. Press on the impeller with the drift SVO 2266 so far that the impeller lies at a level with or 0.4 mm (0.016") just under the surface of the pump housing. The lower end of the shaft should rest against the counterhold, see Fig. 116.
4. Turn the pump. Place a counterhold under the shaft end in the hold of the impeller and press on the hub with drift SVO 2266. As a counterhold, use for example puller SVO 2462 with the centre screw screwed in so that it supports against the shaft. Carefully press so far that dimension B in Fig. 117. will be 105 ± 0.2 mm (4.134 ± 0.008 ").

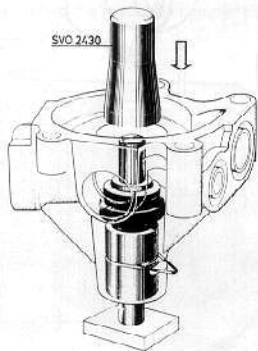

Fig. 115. Fitting the seal ring

5. Check that the pump can be turned by hand without encountering too great a resistance and without any catching or cutting.

FITTING

Make sure when fitting that the seal rings on the upper side of the pump fit in the correct position. Also press the pump upwards against the cylinder head extension while bolting, so that the seal

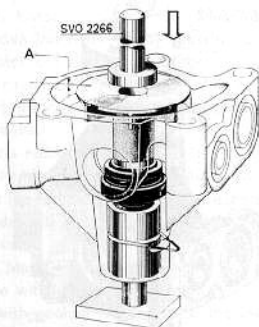

Fig. 116. Fitting the impeller
A = 0–0.4 mm (0–0.016")

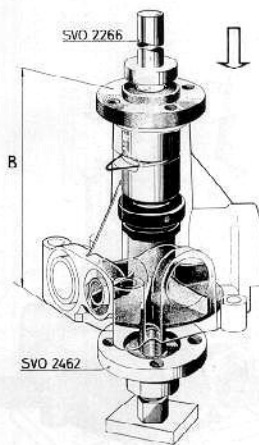

Fig. 117. Fitting the pulley
A = 105 ± 0.2 mm (4.134 ± 0.008 ")

between the pump and the cylinder head will be perfectly satisfactory.

Make sure that the seal rings at the water pipes are not damaged and press in the pipes carefully when fitting.

LEAKAGE CHECK OF COOLING SYSTEM, B 18 ENGINE

The cooling system for B 18 engines is checked for leakage as follows:

Remove the radiator cap and make sure that the filler hole and sealing surface are clean. Connect a cooling system tester (pressure tester) to the

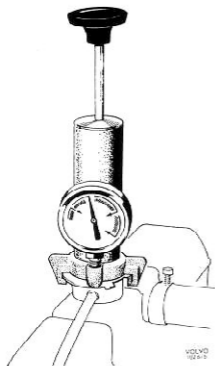

Fig. 118. Pressure testing the cooling system

filler hole (see Fig. 118). Ensure that the rubber sleeve (if fitted) faces in the right direction. Carefully pump up the pressure to 0.5 kg/cm^2 (7 lb/sq.in.). Observe the pressure gauge of the unit. The pressure must not drop much in 30 seconds. If it does, check and repair the leakage.

N.B. Do not let the pressure exceed 0.5 kg/cm^2 (7 lb/sq.in.).

TENSIONING THE PULLEY BELTS

The pulley belt should be tensioned so that the pulley begins to slide at a pull of $8.0\text{--}11.0 \text{ kg}$ ($17.2\text{--}26.2 \text{ lb.}$), applied to the fan at 150 mm ($6''$) from the hub centre. Pull the fan in the direction of the engine rotation and use a spring balance according to Fig. 110. When adjusting, slacken the bolts at the dynamo attachment on the underside of the dynamo, otherwise tension will arise in the attachment, which would then lose its effectiveness.

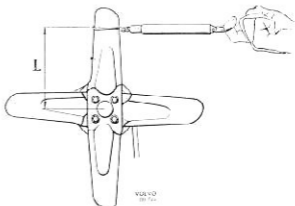

Fig. 119. Pulley belt tension
 $L = 150 \text{ mm}$ ($6''$) Pull $8.0\text{--}11.0 \text{ kg}$, $17.2\text{--}26.2 \text{ lb.}$

FAULT TRACING

FAULT

CAUSE

REMEDY

The engine stalls or idles very unevenly

Faulty sparking plugs or suppressors.

Check and replace sparking plugs and suppressors if necessary.

Air leaks at carburettor connection.

Check for tightness. Replace faulty gaskets.

Idling speed too low.

Increase idling speed.

Dirt in carburettor.

Clean carburettor, particularly idling system.

Engine runs jerkily (or coughs) during acceleration

Dirt on sparking plug insulators.

Clean insulators.

Faulty sparking plugs.

Check or replace sparking plugs.

Dirty, faulty or wet distributor cap.

Remove and clean or replace.

Faulty or wet cables.

Check, clean or replace cables. See also Part 3.

Dirt in carburettor.

Remove floatchamber and needle valve, clean these parts.

Fuel/air mixture too lean.

Check carburettor settings.

Faulty fuel pump supplying too little fuel.

Check fuel pump pressure and capacity.

Low engine output

Air cleaner blocked.

Fit a new paper element or new air cleaner as the case may be. If an oil-bath type air cleaner is fitted, clean it.

Poor quality fuel, too low octane rating.

Check fuel grade, use correct fuel.

Faulty ignition timing setting.

Adjust ignition timing setting by using stroboscope. See "Ignition setting".

Faulty settings on carburettor.

Check and adjust carburettor settings.

Faulty valve clearances.

Check and adjust valve clearance.

Low compression on a cylinder.

Measure compression pressure. In the case of excessively low values, remove cylinder head for closer investigation.

Piston idling.

Remove cylinder head for investigation.

Binding wheel bearings or faulty adjusted brakes.

See Part 5.

Knocking from valve mechanism

Valve clearance too large.

Adjust valve clearances.

Worn or damaged parts in valve mechanism.

Recondition or replace parts where necessary.

Heavy knocking, louder when engine is subjected to loading

Worn main bearings and big-end bearings, or worn pistons and gudgeon pins.

Localize sound by short-circuiting sparking plugs, one at a time.

Then remove to sufficient extent for examination of bearings and pistons.

Low oil pressure

Blocked oil filter. (The engine runs for a longer time than usual after starting before pressure is registered.)

Low oil pressure at lowest idling speed after hard driving.

Faulty oil pressure gauge contact, faulty pressure gauge or gauge line.

Faulty spring in relief valve or pump worn.

One or more bearings worn.

High degree of general wear.

Replace oil filter.

No action necessary. The pressure is normally quite low under these conditions.

Measure pressure with a check gauge.

Replace faulty parts.

Remove oil pump. Check spring and pump.

Examine and replace bearing shells.

Replace or recondition engine.

Large oil consumption

Hard driving.

Leakage at joints.

Oil level too high.

Worn valve guides.

Worn piston rings.

No action necessary. Oil consumption can increase slightly when the engine is subjected to very hard driving.

Tighten bolts and screws, replace faulty or poor quality gaskets all round.

Do not top up with oil until level is down to lower mark on dipstick.

Recondition valve system.

Change piston rings.

Large fuel consumption

Hard driving on highways or intensive stop-and-go town driving.

Blocked air cleaner.

Carburettor flooding.

Faulty carburettor settings, fuel/air mixture too rich.

Faulty sparking plug suppressors, faulty contact breaker points.

Incorrect dwell angle and ignition timing setting.

No measures necessary. Normal in both these cases.

Fit a new paper element or new oil cleaner as the case may be. If an oil-bath type air cleaner is fitted, clean it.

Check and replace float valve if necessary. Also check pump pressure.

Adjust settings.

Replace sparking plug suppressors.

Adjust distributor.

Adjust dwell angle and ignition timing setting.

A stroboscope must be used to adjust the ignition setting.

Engine runs abnormally warm

Not enough cooling water.

Fan belt insufficiently tensioned.

Faulty gauge.

Fuel with too low octane rating (knocking).

Faulty thermostat.

Faulty ignition timing setting.

Faulty carburettor setting (fuel/air mixture excessively lean).

Fill up with cooling water.

Adjust fan belt tension.

Fill up with fuel of correct octane rating.

Replace thermostat.

Check and adjust ignition timing setting by using stroboscope.

Adjust carburettor settings.

P

Cooling system blocked.

Cooling jackets blocked or distribution pipe in cylinder head blocked. Distribution pipe possibly not pushed in far enough.

Clean cooling system.

Measure cooling water temperature simultaneously at outlet on right of thermostat and at outlet for temperature gauge at rear of cylinder head. If the temperature obtained at the temperature gauge outlet at the rear is higher, the cylinder head should be removed and examined.

Loss of cooling water

Leaks at hose connections.

Faulty radiator filler cap.

Faulty cylinder head gasket (oil in cooling water).

Check hoses and clamps, replace if necessary.

Replace radiator filler cap.

Replace cylinder head gasket.

- | | |
|--|---------------------------------------|
| 1. Water distribution pipe | 40. Gasket |
| 2. Intake manifold | 41. Main bearing shell |
| 3. Seal ring | 42. Oil pump |
| 4. Exhaust valve | 43. Delivery pipe |
| 5. Fuel hose | 44. Crankshaft |
| 6. Ventilation cover
(oil filler cap) | 45. Camshaft |
| 7. Valve cotter | 46. Piston |
| 8. Inlet valve | 47. Piston rings |
| 9. Carburettor | 48. Connecting rod |
| 10. Plug for damper piston | 49. Circlip |
| 11. Upper valve washer | 50. Gudgeon pin |
| 12. Valve spring | 51. Big-end bearing shell |
| 13. Valve guide | 52. Connecting rod bush |
| 14. Rocker arm | 53. Thrust washer and
spacer ring |
| 15. Rocker arm shaft | 54. Camshaft gear |
| 16. Spring | 55. Timing gear casing |
| 17. Lower valve washer | 56. Crankshaft gear |
| 18. Push rod | 57. Hub |
| 19. Bearing bracket | 58. Washer |
| 20. Rocker casing | 59. Belt pulley |
| 21. Gasket | 60. Bolt |
| 22. Cable terminal | 61. Fan |
| 23. Cylinder head | 62. Key |
| 24. Vacuum line | 63. Oil nozzle |
| 25. Distributor | 64. Key |
| 26. Valve tappet | 65. Lock washer
(early production) |
| 27. Flywheel housing | 66. Cooling water inlet |
| 28. Retainer | 67. Gasket |
| 29. Cylinder block | 68. Water pump |
| 30. Gear wheel | 69. Dynamo |
| 31. Circlip | 70. Belt pulley |
| 32. Pilot bearing | 71. Gasket |
| 33. Flywheel | 72. Seal ring |
| 34. Bush | 73. Tensioner |
| 35. Flange bearing shell | 74. Cylinder head gasket |
| 36. Sealing flange | 75. Thermostat |
| 37. Main bearing cap | 76. Gasket |
| 38. Reinforcement | 77. Cooling water outlet |
| 39. Sump | |

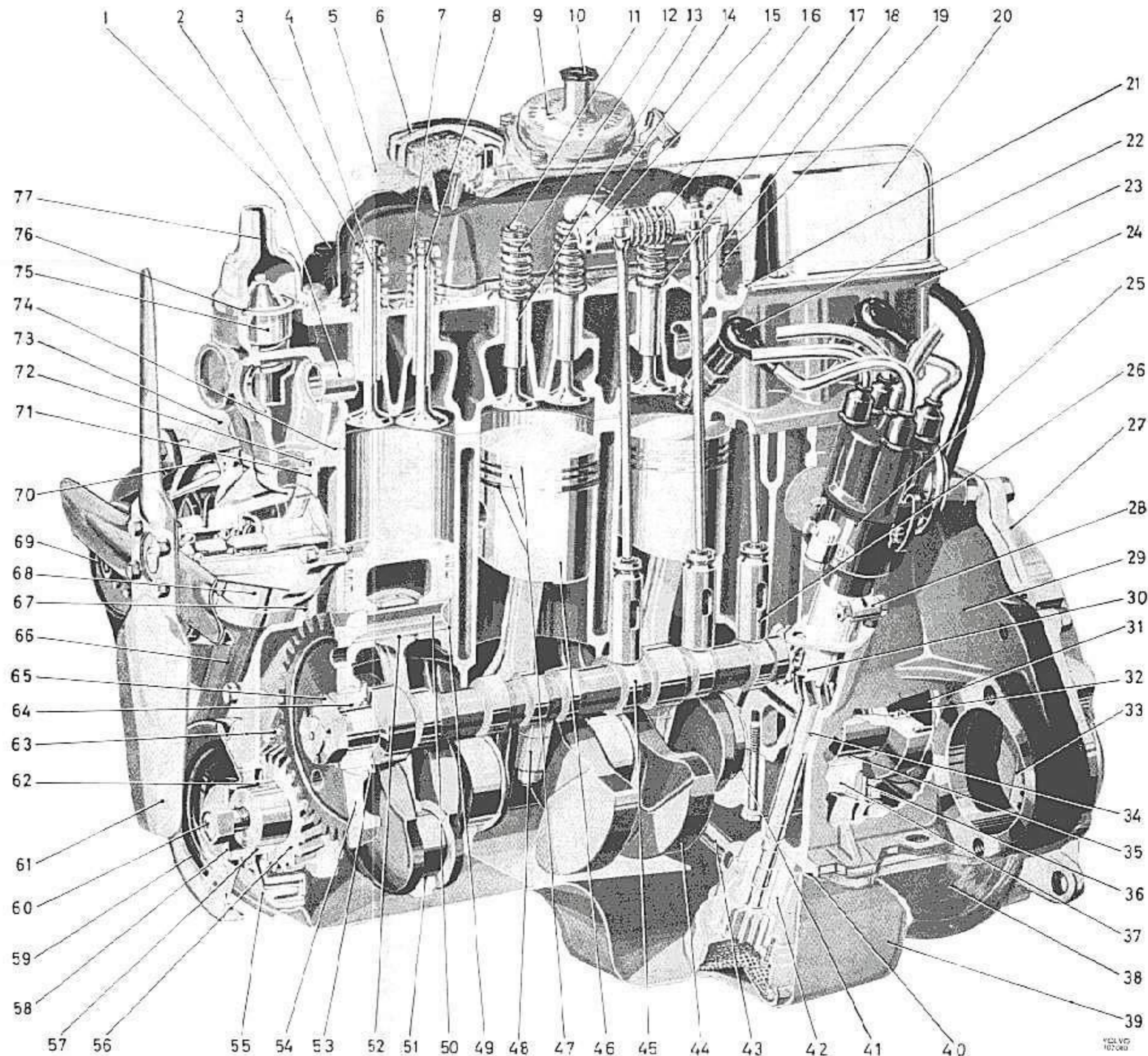

Illustration A. Sectional view of B 18 A engine