



PART 4 (43 a)  
OVERDRIVE  
120, 140, 1800

**CARS**

**SERVICE  
MANUAL**

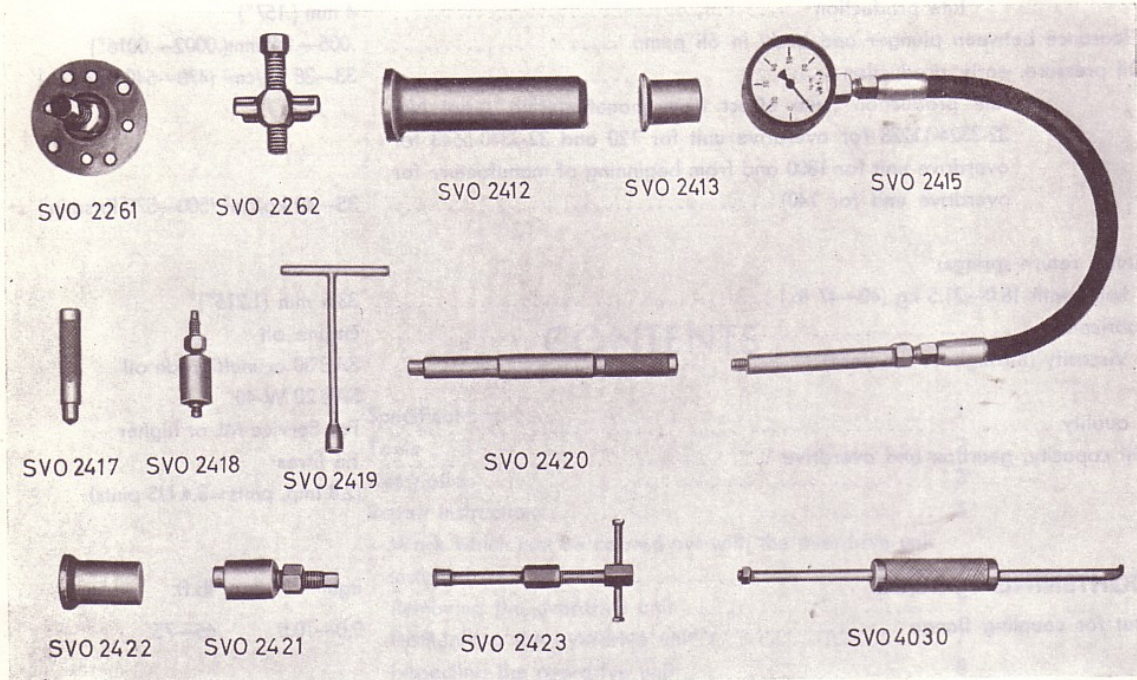
## CONTENTS

Specifications .....	1
Tools .....	2
Description .....	3
Repair Instructions .....	5
Work which can be carried out with the overdrive unit	
installed .....	5
Removing the overdrive unit .....	7
Dismantling the overdrive unit .....	7
Inspecting the overdrive unit .....	8
Assembling the overdrive unit .....	9
Installing the overdrive unit .....	12
Fault Tracing .....	13
Illustrations A and B	



## SPECIAL TOOLS

The following special tools are required for work on the overdrive unit.



- SVO 2261 Puller for round coupling flange.
- SVO 2262 Puller for U-section coupling flange.
- SVO 2412 Drift for fitting front bearing on output shaft.
- SVO 2413 Drift for fitting rear bearing on output shaft.
- SVO 2415 Pressure gauge for checking oil pressure.
- SVO 2417 Drift for removing planet gear needle bearings and for fitting bearings in planet gears and output shaft.

- SVO 2418 Extractor for oil pump.
- SVO 2419 Key for oil pump non-return body.
- SVO 2420 Centring mandrel for splines in planet carrier and uni-directional clutch.
- SVO 2421 Press tool for fitting coupling flange.
- SVO 2422 Drift for fitting oil seal on output shaft.
- SVO 2423 Extractor for needle bearing on output shaft.
- SVO 4030 Extractor for oil seal on output shaft.

## DESCRIPTION

(Unless otherwise stated, the reference numbers in brackets refer to Illustration B.)

The overdrive unit is of the epicyclic type and is attached to the rear end of the gearbox. The construction of the overdrive is shown in Fig. 1 and Illustrations A and B.

The working principle of the overdrive is as follows: In the direct drive position the clutch sliding member (43) is in position I, Fig. 2. When travelling forwards the power is transmitted from the gearbox mainshaft (59) through the uni-directional clutch (33, 34) to the output shaft (25). When reversing or when the engine acts as a brake, the torque is transmitted through the clutch sliding member. This is possible since the clutch sliding member is pressed against the tapered part of the output shaft by means of four clutch return springs (54). In the overdrive position the clutch sliding member is pressed against the brake ring (41), see II, Fig. 2, thereby locking the sunwheel. This means that the planet gears (38) are forced to rotate around the sunwheel (46). As a result of this, the output shaft will rotate at a higher speed than the mainshaft.

The overdrive is engaged by electro-hydraulic means. On the gearbox cover there is a contact which cuts in when 2nd or 3rd speed on the M-31 gearbox or 4th speed on the M-41 gearbox are engaged. The overdrive can only operate when this contact is cut in, i.e. with 2nd or 3rd speed on the M-31 or 4th speed on the M-41 engaged.

The overdrive is switched on by means of a switch placed underneath the steering wheel or on the instrument panel. This switch closes the circuit via the contact on the gearbox to a solenoid (4) on the overdrive, see Fig. 3.

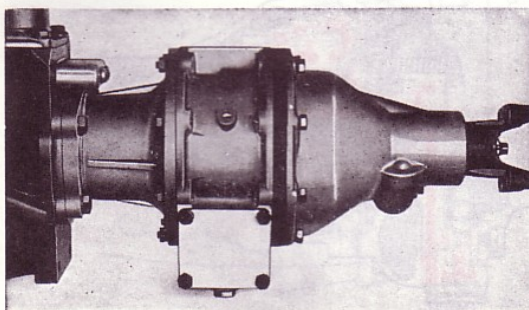


Fig. 1. Overdrive unit

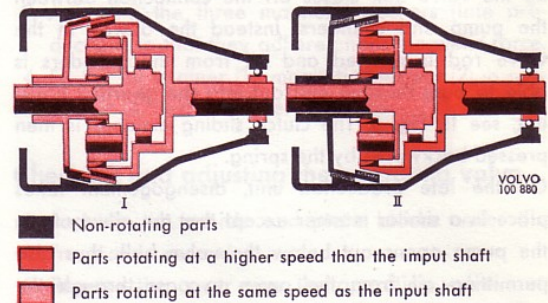


Fig. 2. Working principle of the overdrive

I Direct drive position  
II Overdrive position

The solenoid has two windings, a heavy operating winding and a fine holding winding. The operating winding causes the solenoid armature to move in such a way that the operating valve in the overdrive opens. After the valve has opened, the current through the operating winding is cut off and the valve is then held in the open position by the holding winding. There is a plunger pump (4, Fig. 4) in the overdrive unit which is driven by a cam on the mainshaft. When the operating valve (6) opens (position I, Figs. 5 and 6) oil under pressure from the pump flows through the valve to two cylinders (1). The pistons in these cylinders then press the clutch sliding member forwards to engage with the brake ring.

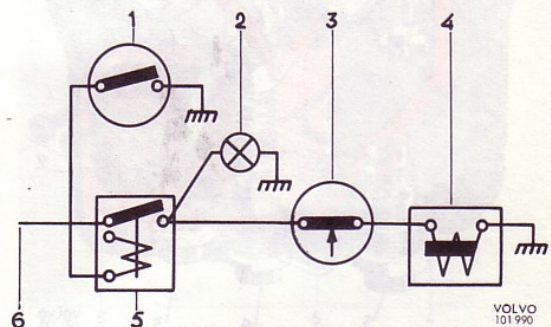


Fig. 3. Electrical circuit diagram

- |                                 |                          |
|---------------------------------|--------------------------|
| 1. Switch for overdrive         | 4. Solenoid on overdrive |
| 2. Indicator lamp for overdrive | 5. Relay for overdrive   |
| 3. Contact on gearbox           | 6. Lead from fusebox     |

The working principle when disengaging differs slightly depending on whether the overdrive is of early or late production.

On the early production overdrive unit, disengagement takes place by lowering of the valve rod, whereby the valve ball closes off the connection between the pump and cylinders. Instead the oilway in the valve rod is opened and oil from the cylinders is able to pass through and out into the gearbox housing, see II, Fig. 5. The clutch sliding member is then pressed backwards by the spring.

On the late production unit, disengagement takes place in a similar manner except that the oilway from the pump opens out below the valve ball, thus also permitting oil from the pump to pass through the valve rod and back to the gearbox housing. This enables the pump to work at a lower loading in the direct drive position, see Fig. 6.

On the late production unit the surplus oil from the pump is utilized for lubricating the epicyclic gear. The oil passes through oilways in the front part of the overdrive housing and input shaft (gearbox mainshaft) to the uni-directional clutch and needle bearing for the shaft. The oil is then collected by a plate and fed back to the gearbox housing through the planet gears, see Fig. 7.

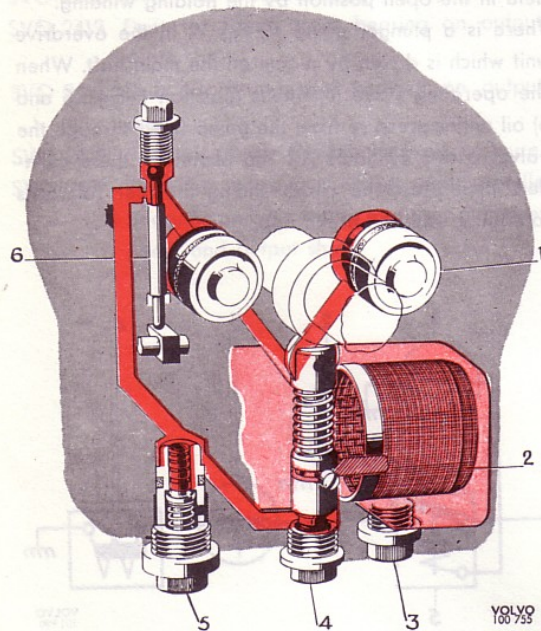


Fig. 4. Hydraulic system, late production

- |                                  |                    |
|----------------------------------|--------------------|
| 1. Hydraulic cylinder and piston | 4. Oil pump plug   |
| 2. Oil strainer                  | 5. Relief valve    |
| 3. Drain plug                    | 6. Operating valve |

4 : 4

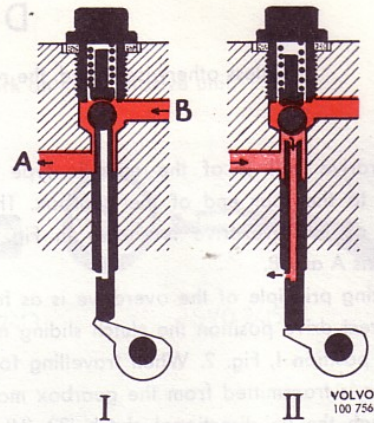


Fig. 5. Operating valve, early production

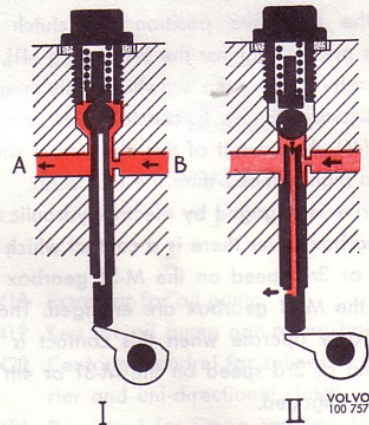


Fig. 6. Operating valve, late production

- |                           |                          |
|---------------------------|--------------------------|
| I. Overdrive position     | A. To hydraulic cylinder |
| II. Direct drive position | B. From oil pump         |

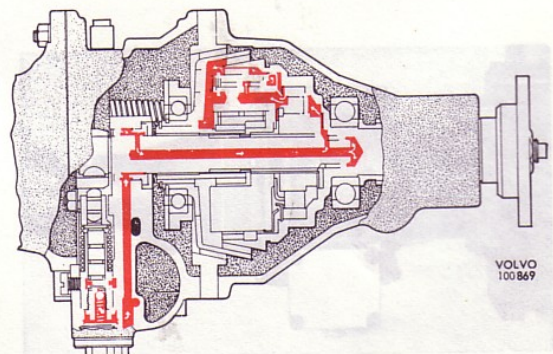


Fig. 7. Oil flow for force feed lubrication

## REPAIR INSTRUCTIONS

### WORK WHICH CAN BE CARRIED OUT WITH THE OVERDRIVE INSTALLED

#### Checking the oil pressure

1. Disengage the overdrive (late production) so that any residual oil pressure is released. On the early production unit it may be necessary to engage and disengage the overdrive 10—12 times in order to do this.
2. Remove the plug over the operating valve and connect pressure gauge SVO 2415 as shown in Fig. 8.
3. Start and run the vehicle. (Testing can also be done with the vehicle jacked up.) At a speed of 50—60 km.p.h. (30—37 m.p.h.) in overdrive, the pressure gauge should give a reading of 35—40 kg/cm<sup>2</sup>=500—570 lb/sq.in. (early production: 33—38 kg/cm<sup>2</sup>=470—540 lb/sq.in.). If the pressure gauge gives too low a reading, see under "Fault Tracing" for the reason and necessary action.

#### Cleaning the oil strainer

The oil strainer should be cleaned at every oil change. First drain the oil by removing the plug (3, Fig. 4, marked "Drain") under the oil strainer. Cleaning is then done as follows:

1. Remove the cover (5, Fig. 9). Take out the oil strainer (1) and magnetic element (2). Clean the oil strainer in petrol or white spirit. Blow dry with compressed air.

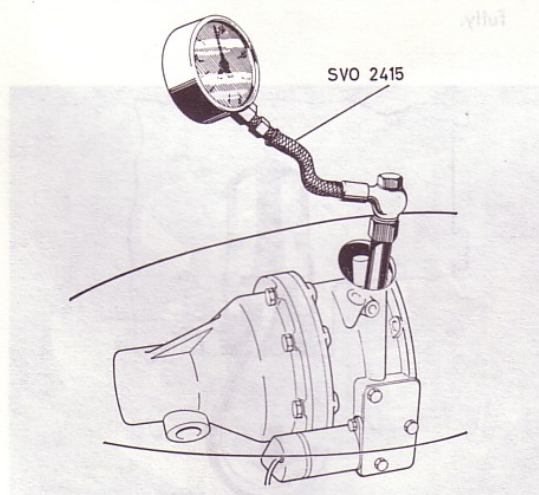


Fig. 8. Checking the oil pressure

2. Check that the oil strainer gasket (3) is in good condition. Turn the steel covered side to face the housing and place the gasket in position.
3. Assemble the three magnetic washers (late production) so that they adhere under magnetic force.
4. Fit the oil strainer (1), magnetic element (2), a new gasket (4) and the cover (5).

#### Checking and adjusting the operating valve

1. Jack up the vehicle and place blocks under the front and rear axles.
2. Remove the cover over the operating valve arm. Engage the overdrive (with engine stationary and 4th speed engaged). When the operating valve is correctly adjusted it should be possible to insert a 4.75 mm (.19") diameter pin through the hole in the arm and into the body, see Fig. 10. If not, adjust the position of the arm until this can be done.
3. Check the current through the solenoid with the overdrive engaged. This should be not more than 1 A with a 12 V system and not more than 2 A with a 6 V system. If the current is 10—12 A or higher, this means that the solenoid armature does not move sufficiently to cut off the operating current.

N.B. If the current through the solenoid is too high, the reason for this must be determined and necessary action taken, otherwise the solenoid will be ruined.

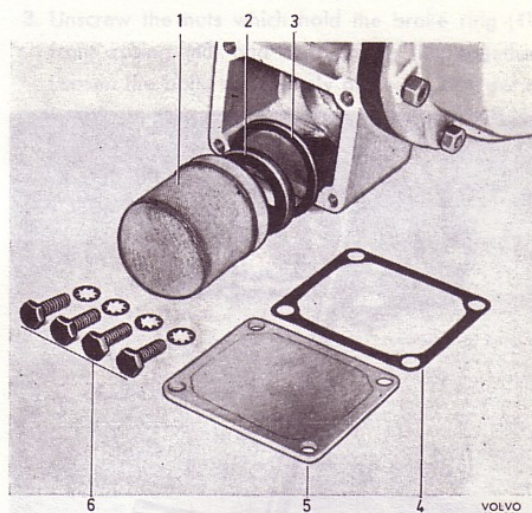
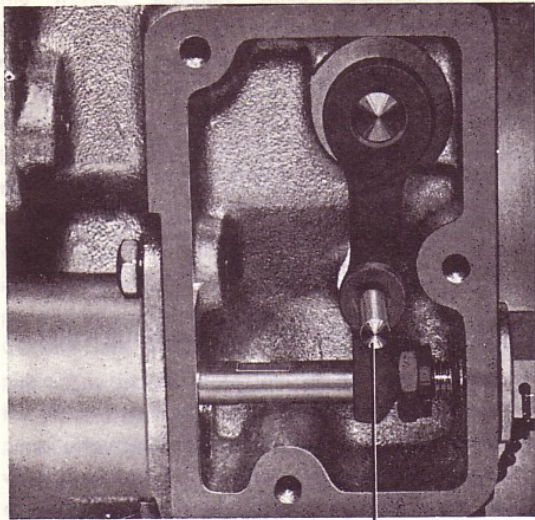


Fig. 9. Removing the oil strainer

- |                                       |                     |
|---------------------------------------|---------------------|
| 1. Oil strainer                       | 4. Gasket for cover |
| 2. Magnetic element (late production) | 5. Cover            |
| 3. Gasket for oil strainer            | 6. Bolts            |

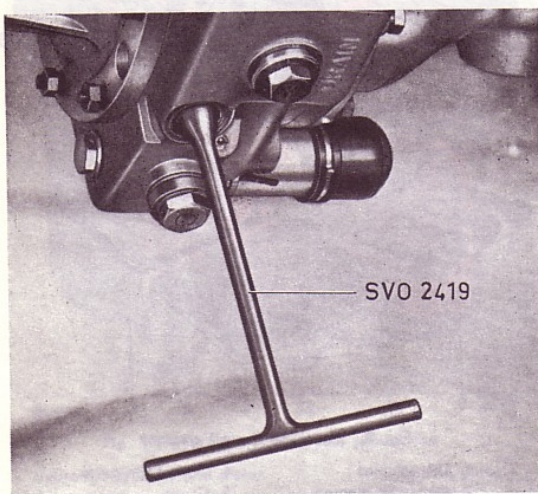


VOLVO  
24602

Fig. 10. Adjusting the operating valve  
1. Control pin, diameter 4.75 mm (.19")

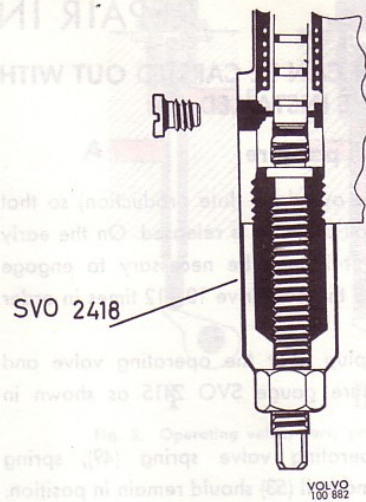
### Checking the oil pump

1. Disengage the overdrive (late production, and on early production by engaging and disengaging 10—12 times) in order to release any residual oil pressure. Jack up the vehicle and place blocks under the front and rear axles. Remove the drain plug and let the oil run out into a collecting vessel.
2. Remove the plug under the oil pump and take out the spring (8) and ball (6). Remove the non-return body (7) with key SVO 2419, see Fig. 11. Clean and check the parts.



VOLVO  
24742

Fig. 11. Removing non-return body, oil pump



VOLVO  
100 882

Fig. 12. Removing the oil pump

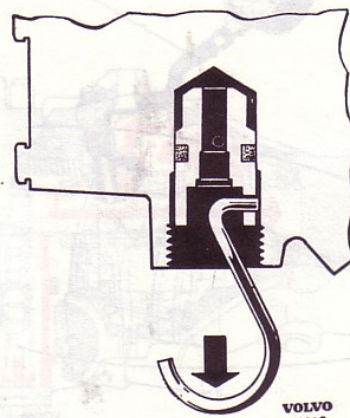
3. Feel with a piece of wire or similar against the pump plunger that the pump operates when the output shaft is rotating. (Turn round the engine a few times with the starter motor with gear engaged and lead from the ignition coil disconnected.)

The pump plunger stroke should be 3.2 mm (.126") early production) or 4 mm (.157") (late production). If the pump plunger stroke is shorter than this, the pump must be removed and the reason ascertained.

4. The pump is removed as follows:

Loosen the pump retaining bolt through the hole in the extension casing (58). Attach puller SVO 2418 in place of the non-return body and pull out the pump, see Fig. 12.

5. Dismantle the pump parts and check them carefully.



VOLVO  
24603

Fig. 13. Removing relief valve body

6. The pump and pump valve are fitted in the reverse order to removal. Check that the washer for the plug (4, Fig. 4) is in good condition. Fill up with oil.

### Checking the relief valve

1. Disengage the overdrive (late production, and on early production by engaging and disengaging 10—12 times) in order to release any residual oil pressure. Jack up the vehicle and place blocks under the front and rear axles. Remove the drain plug and let the oil run out into a collecting vessel.
2. Remove the plug and take out the spring (11) and valve plunger (12). Pull out the valve body (10) with a small hook as shown in Fig. 13.
3. Clean and check all seals carefully. Fit the parts in the reverse order to removing.

N.B. When altering the oil pressure with the washer under the spring, it can be taken as a guide that a 0.1 mm (.004") thick washer will alter the pressure about 1 kg/cm<sup>2</sup> (14 lb/sq.in.).

### Cleaning the operating valve

1. Disengage the overdrive (late production, and on early production by engaging and disengaging 10—12 times) in order to release any residual oil pressure.
2. Remove the plug over the operating valve and the spring (49), spring plunger (52), ball (53) and valve rod (16). The ball can be lifted up with a small magnet or a looped piece of fine steel wire and the valve rod with a magnet or pointed piece of wood pushed into the valve rod hole.

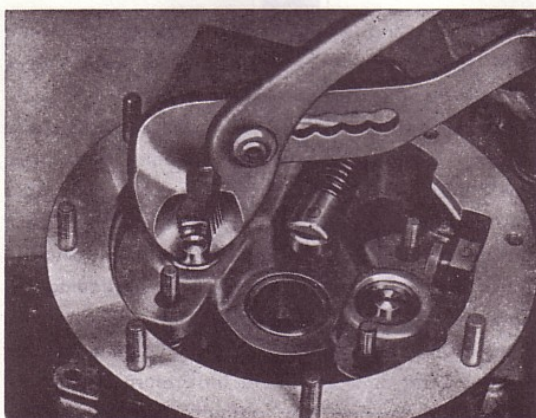


Fig. 14. Removing piston

VOLVO  
24684

3. Clean the various parts carefully. The valve rod hole (late production) should be cleaned out with a 3.1—3.2 mm drill and the valve hole with a 1.1 mm drill. For early production valve rod use 3.1—3.2 mm and .7 mm drills respectively.
4. Fit the parts in the reverse order to removal.

### REMOVING THE OVERDRIVE UNIT

1. Carry out operations 1—4 under "Removing" in Service Manual, Part 4 (43), Gearbox M30-M40. Also drain out the oil from the overdrive unit.
2. Disconnect the cable to the solenoid.
3. Unscrew the bolts which hold the overdrive unit to the intermediate flange and remove the overdrive unit.

### DISMANTLING THE OVERDRIVE UNIT

The following description concerns complete dismantling of the overdrive unit. However, it is seldom necessary to dismantle it completely, so that only the appropriate parts of this description need to be followed when dismantling.

1. Remove the cover over the oil strainer and the cover over the operating lever (13). Take out the oil strainer. Unscrew the bolts and lift out the solenoid (18).
2. Bend down the locking tabs, unscrew and remove the nuts for the piston bridge pieces (56). Remove the bridge pieces. Pull out the pistons with the help of pliers as shown in Fig. 14.
3. Unscrew the nuts which hold the brake ring (41), front casing (48) and rear casing (20) together. Loosen the bolts successively all round in order to avoid any distortion from the springs. Lift off the front casing and brake ring.
4. Lift out the clutch sliding member (43) complete with thrust bearing and sunwheel. Remove the

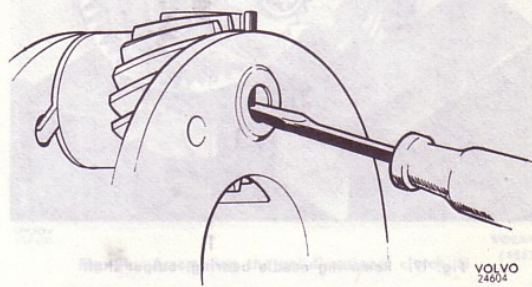


Fig. 15. Removing locking pins in planet gear shafts

VOLVO  
24605

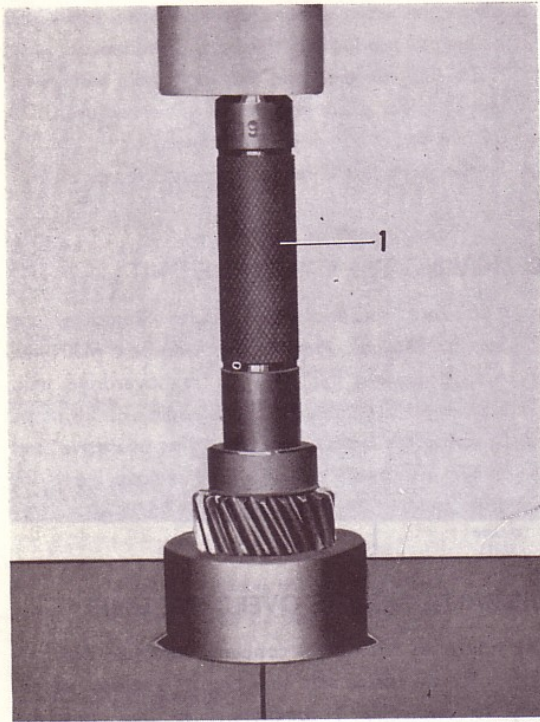


Fig. 16. Removing needle bearing in planet gear  
1. Drift SVO 2417

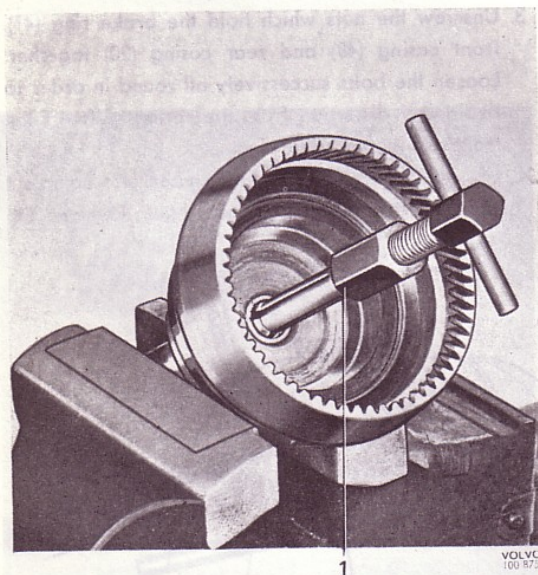


Fig. 17. Removing needle bearing, output shaft  
1. Extractor SVO 2423

four return springs and thrust plate. Remove the circlips for the sunwheel (46) and bearing. Take out the sunwheel. Pull off the bearing from the clutch sliding member. Press out the bearing from the retainer.

5. Lift off the planet gears (38) and planet carrier (45). Remove the locking pins (42) for the planet gear shafts by first pressing them out with a drift or similar, see Fig. 15, and then removing them with pliers. If this cannot be done, drill out the pins with a suitable drill. Press out the planet gear shafts and remove the planet gears. The planet gear needle bearing can be pressed out with drift SVO 2417, Fig. 16.
6. Loosen the screw and pull out the bush and speedometer pinion. Loosen the nut for the coupling flange (26). Pull off the flange. Use puller SVO 2261 for round flanges and SVO 2262 for other types. Place the housing in a press and press out the output shaft (25).
7. Remove the circlip (36) (late production) and oil thrower (retaining washer) (35) which holds the uni-directional clutch on the output shaft. Lift out the parts of the uni-directional clutch. Remove the thrust washer (32). If necessary, pull out the needle bearing (31) in the output shaft with tool SVO 2423, see Fig. 17. Pull off the bearing on the output shaft with a suitable puller.
8. Remove the plugs and take out the parts for the operating valve, relief valve and outlet valve for the pump. Remove the locking screw and take out the oil pump. If the pump is difficult to remove, first remove the non-return body with key SVO 2419 as shown in Fig. 11. Then pull out the pump with puller SVO 2418, see Fig. 12.

### INSPECTING THE OVERDRIVE UNIT

Before inspecting, wash all parts thoroughly in white spirit. Then carefully check all parts for wear, cracks or other damage. Renew any faulty parts.

Check the ball and needle bearings for cracks, wear or other damage on the balls, needles and races. Check the uni-directional clutch. The rollers and races must not show any signs of cracking or nicking. Check that the outer race fits securely in the output shaft. Check the planet gears. In the event of damage to the teeth, the gears must be renewed.

Check that the linings on the clutch sliding member are not burnt or worn. Check that return springs are undamaged and have not "settled". Check the surface on the thrust bush for the sunwheel in the front casing.

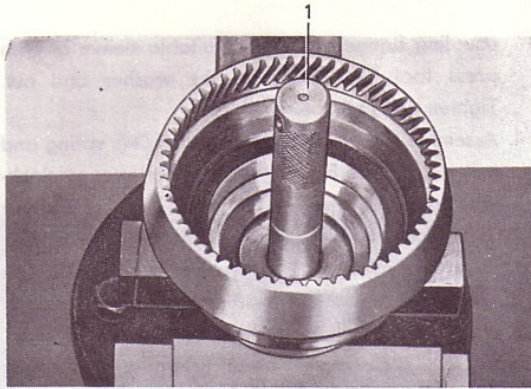


Fig. 18. Fitting needle bearing, output shaft

1. Drift SVO 2417

It is only necessary to replace the bush if the surface is deeply scored. Due to the close concentricity tolerances, the front casing complete with bush must be renewed in this event. Check the oil pump for damage on the plunger and roller.

Check that the plunger slides easily in the body. Make sure that the plunger spring is not damaged. Check the non-return body and ball to make sure that they are not burred or scored. Check the operating valve for damage and make sure that it moves freely in the bore in the front casing.

Check the relief valve. N.B. The relief valve plunger and seat are matched by lapping, so that if either is damaged both must be renewed.

Check the cylinders for the operating pistons for scoring and wear.

Make sure that the oilways are clean.

Fit the other parts in the reverse order to removal.

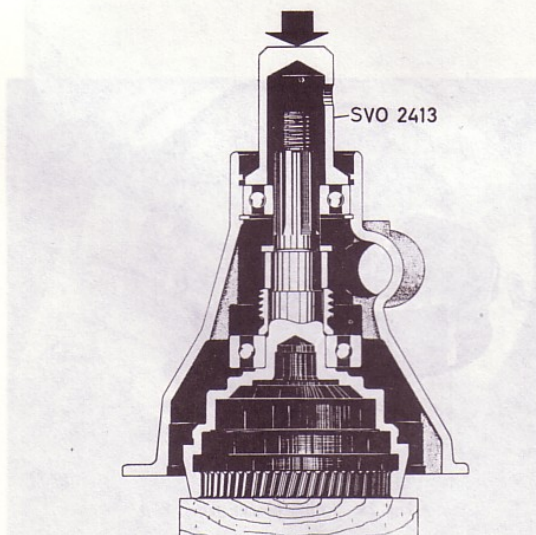


Fig. 19. Fitting the output shaft

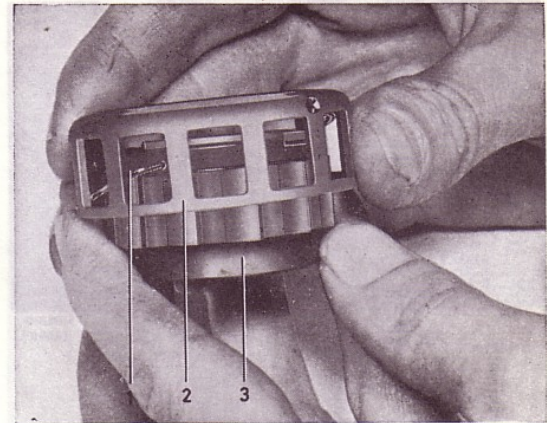


Fig. 20. Assembling the uni-directional clutch, I

1. Spring 2. Cage 3. Uni-directional clutch

### ASSEMBLING THE OVERDRIVE UNIT

1. Place the front circlip for the bearing (28) in the roller casing. Press in the bearing with drift SVO 2413.

2. Press the support bearing (31) for the gearbox mainshaft in the output shaft (25) with drift SVO 2417, see Fig. 18. Press the front bearing on the output shaft with drift SVO 2412.

3. Support under the output shaft with a block of wood. Fit on the speedometer driving gear (30), spacer (29) and thrust washer (24). Press on the rear casing with drift SVO 2413, see Fig. 19. Fit on the circlip for the rear bearing. Press in the oil seal (27) with drift SVO 2422. Press on the end locking wire.

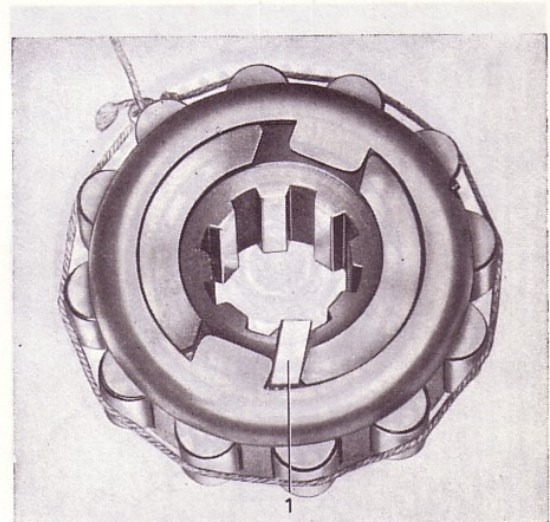


Fig. 21. Assembling the uni-directional clutch, II

1. Key

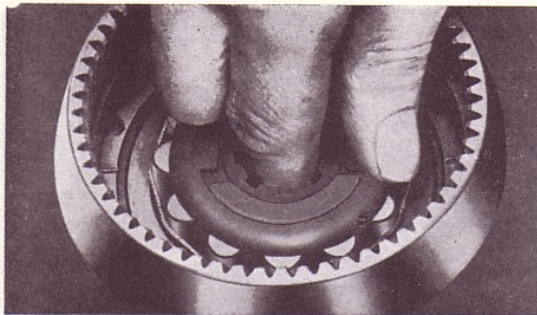


Fig. 22. Fitting the uni-directional clutch VOLVO  
24690

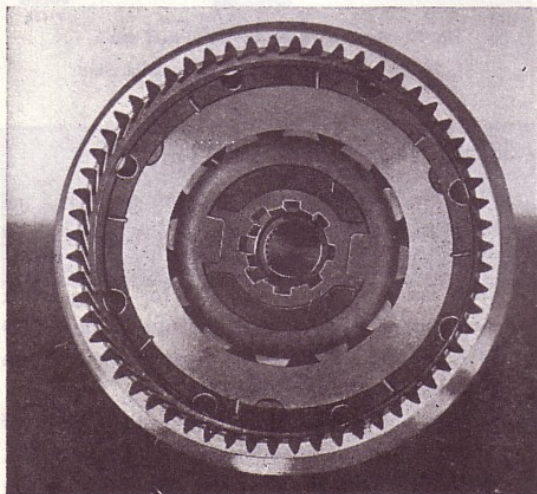


Fig. 23. Fitting retaining washer, early production VOLVO  
24691

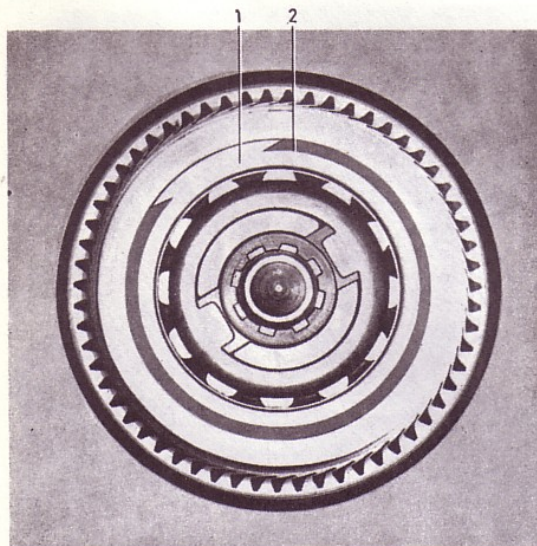


Fig. 24. Fitting oil thrower, late production VOLVO  
100 873  
1. Oil thrower 2. Circlip

coupling flange (26) with a suitable sleeve or with press tool SVO 2421. Fit the washer and nut. Tighten and lock the nut.

4. Assemble the uni-directional clutch (34), spring and roller cage, see Fig. 20. Turn the roller cage clockwise as far as it will go and lock it in this position with a key as shown in Fig. 21. Place in the rollers. Tie a piece of string or rubber band round the rollers. Fit the thrust washers and then the uni-directional clutch in position on the output shaft, see Fig. 22. Fit the brass retaining washer as shown in Fig. 23. On early production units the washer is attached with centre punch pops or chisel indentations. On late production units the washer is attached with a circlip, see Fig. 24.
5. Press the needle bearings (39) in the planet gears (38) with drift SVO 2417. The bearings should come slightly below the side surfaces of the gears. Assemble the planet carrier, shafts, washers and planet gears, see Fig. 25. Line up the splines in the planet carrier and uni-directional clutch with centring mandrel SVO 2420, see Fig. 26.
6. Fit the sunwheel (46) in the clutch sliding member (43). Assemble the bolts, thrust bearing and thrust bearing retainer. Fit the thrust bearing on the clutch sliding member.
7. Fit the operating piston (14) in the front casing. Assemble the clutch sliding member, brake ring (41), clutch return springs (54), front casing and bridge pieces (50 and 56) as shown in Fig. 27. When assembling, coat both sides of the clutch ring with sealing compound.

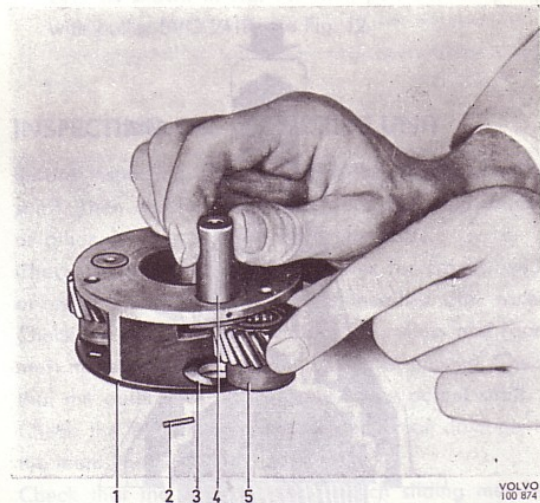
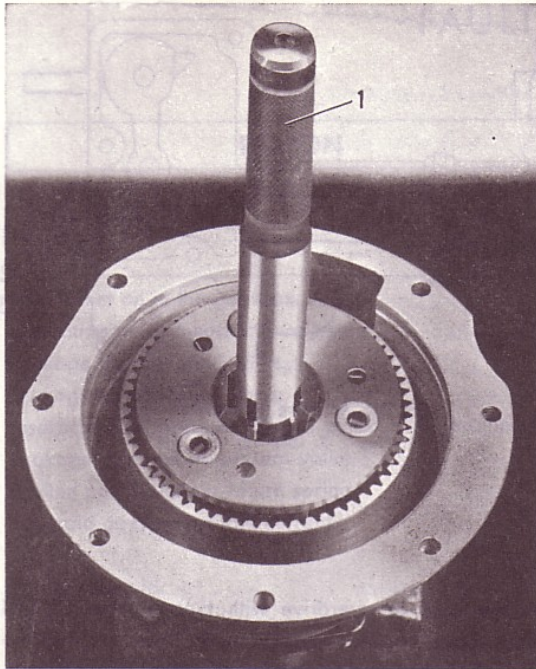


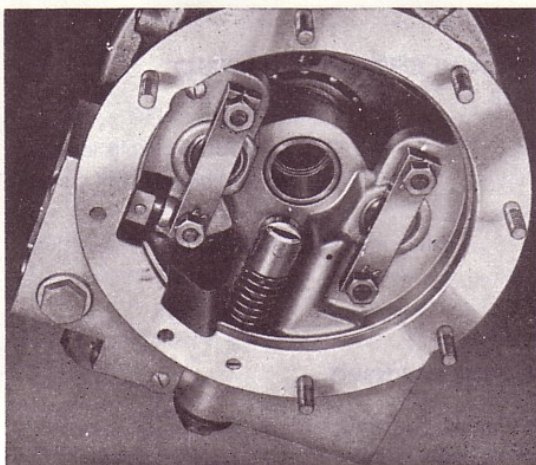
Fig. 25. Fitting planet gears, I VOLVO  
100 874

- |                   |                |
|-------------------|----------------|
| 1. Planet carrier | 4. Shaft       |
| 2. Locking pin    | 5. Planet gear |
| 3. Thrust washer  |                |

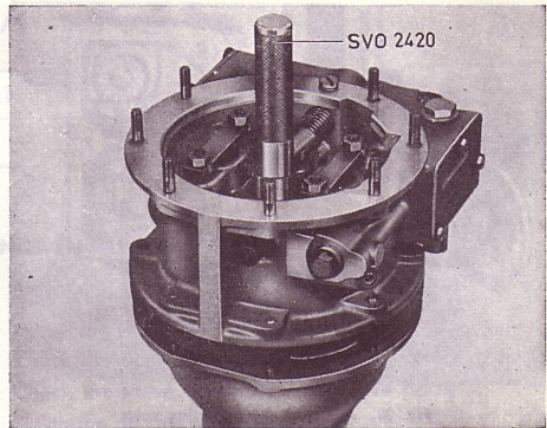


**Fig. 26. Fitting planet gear, II**  
1. Centring mandrel SVO 2420

8. Place the assembled unit as described in point 7 on the rear casing. Line up the splines in the planet carrier and uni-directional clutch with mandrel SVO 2420, see Fig. 28. Fit on the washers and nuts. Tighten the nuts a little at a time until they are evenly tightened all round.
9. Fit the other parts in the reverse order to removal.



**Fig. 27. Assembling the front casing**



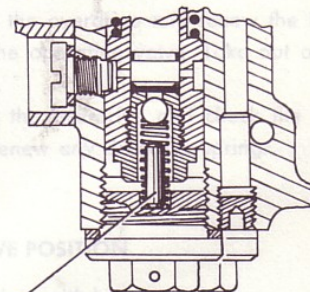
**Fig. 28. Fitting the front casing**

When doing this, note the following:

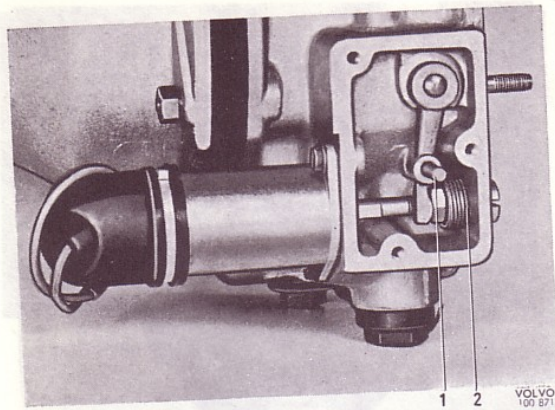
There are two different types of plug and spring for the non-return valve of the pump. Early production plugs must not be used together with late production springs or vice versa, but replacement must be done in matched pairs. See also the spare parts catalogue.

Fit the guide pin (A, Fig. 29) in the non-return valve spring.

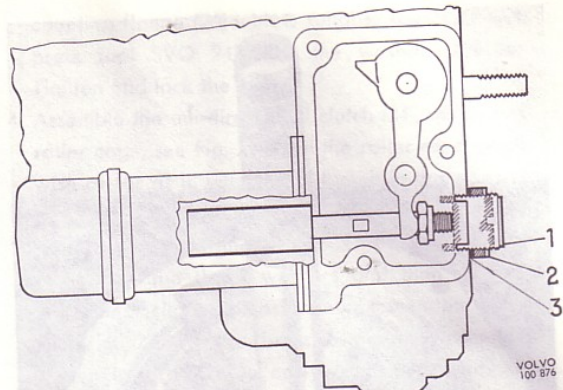
Screw in the plug so that the solenoid armature bottoms. Then check that a 4.75 mm (.19") diameter pin can be inserted through the hole in the arm and into the body as shown in Fig. 30. Adjust as necessary. After adjustment, screw out the plug 2½ turns, see Fig. 31, and lock with the lock nut and locking wire.



**Fig. 29. Non-return valve for oil pump**  
A. Guide pin



**Fig. 30. Adjusting the operating valve**  
 1. Checking pin, diameter 4.75 mm (.19")  
 2. Adjustable plug



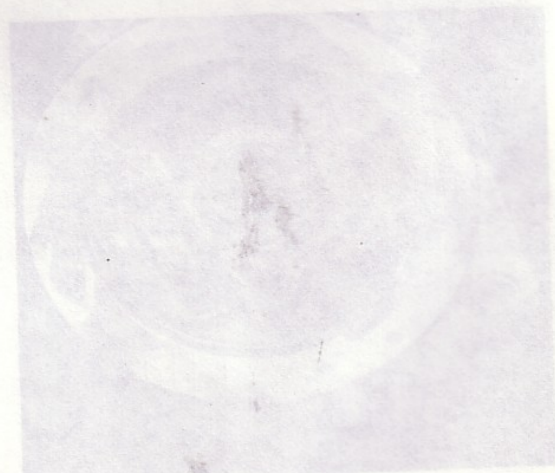
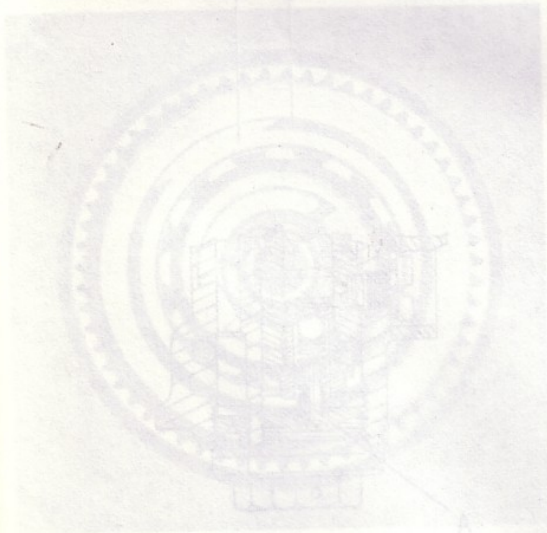
**Fig. 31. Adjusting the adjustable plug**  
 1. Plug 2. Lock nut 3. Washer

### INSTALLING THE OVERDRIVE UNIT

Make sure that the cam (57) for the oil pump on the mainshaft is turned upwards. Then fit the overdrive unit in the reverse order to removal. Fill up with oil. Auto Transmission overdrives type number 32/3324 and above have force feed lubrication of the planet gear needle bearings and output shaft. The part number of the gearbox mainshaft is unaltered. This means that when fitting a new mainshaft

in the case of overdrive with type number 32/3324 and above, a check must be made to ensure that the mainshaft is drilled. If a new overdrive is fitted on a gearbox which has an early production mainshaft, the mainshaft must be replaced with an early production type.

An exception to this is the 32/3333, which does not have force feed lubrication.



## FAULT TRACING

### FAULT

REASON	NECESSARY ACTION
<b>OVERDRIVE DOES NOT ENGAGE</b>	
<p>Insufficient oil in the gearbox.            Operating valve incorrectly adjusted.            Leakage on operating valve.            Leakage on operating valve.            Insufficient oil pressure due to blocked oil strainer.            Leakage at pump non-return valve.            Broken pump plunger return spring.            Solenoid does not obtain current.            Faulty solenoid.</p>	<p>Fill up with oil to the level plug.            Adjust the valve, see page 4:5.            Check the operating valve and renew defective parts.            Check the valve and renew defective parts.            Clean the oil strainer.            Check the valve and renew defective parts.            Remove the pump and renew the plunger spring.            Check the parts in the circuit.            (See circuit diagram, Fig. 3, on page 4:3).            Renew the solenoid.</p>
<b>OVERDRIVE DOES NOT DISENGAGE</b>	
<p>N. B. This fault must be attended to immediately. The vehicle must <b>not</b> be reversed with the overdrive engaged as this can cause severe damage.</p>	
<p>Incorrectly adjusted operating valve.            Oilway in valve rod blocked.</p>	<p>Adjust the valve, see page 4:5.            Remove the operating valve. Take out and clean the valve rod.</p>
<b>CLUTCH SLIPS IN OVERDRIVE POSITION</b>	
<p>Insufficient oil in gearbox.            Worn or glazed clutch linings.            Insufficient oil pressure.</p>	<p>Fill up with oil to the level plug.            Dismantle the overdrive and renew the linings.            Check the oil pressure, see page 4:5.            See also under "Overdrive does not engage".</p>
<b>CLUTCH SLIPS IN DIRECT DRIVE POSITION WHEN REVERSING OR WHEN USING ENGINE AS BRAKE</b>	
<p>Worn or glazed clutch linings.            Oilway in valve rod blocked.            Insufficient return spring pressure on clutch.</p>	<p>Dismantle the overdrive and renew the linings.            Remove the operating valve. Take out and clean the valve rod.            Dismantle the overdrive and check the clutch return springs. Renew any defective springs.</p>
<b>OVERDRIVE ENGAGES IN DIRECT DRIVE POSITION</b>	
<p>N.B. Only applies to late production overdrives with by-pass lubricating system in direct drive.</p>	
<p>Valve rod and return hole of operating valve blocked.</p>	<p>Clean the operating valve, see page 4:5.</p>

**FAULT TRACING WITH PRESSURE GAUGE SVO 2415  
TYPE I**

**Insufficient oil pressure in both direct drive and overdrive positions**

Oil level too low.  
Blocked oil strainer.  
Leakage on non-return valve.  
Broken pump plunger return spring.  
Pump plunger binds.

Fill up with oil to the level plug.  
Clean the oil strainer.  
Check the valve and renew defective parts.  
Remove the pump and renew the plunger spring.  
Remove the pump. Clean the plunger and cylinder bore and renew if necessary.  
Check the valve and renew defective parts.  
Place a washer under the defective valve spring if necessary. As a guide in selecting a washer of suitable thickness it can be taken that a thickness of 0.1 mm (.004") alters the pressure by about 1 kg/cm<sup>2</sup> (14 lb/sq.in.).

Defective relief valve.

**Insufficient oil pressure in direct drive position**

Operating valve ball does not seal against the seat in the body.

Check the operating valve and renew defective parts.  
Try tapping the ball lightly against the seat with a soft drift.

**Insufficient oil pressure in overdrive position**

Operating valve ball does not seal against valve rod seat.

Remove and clean the ball and valve rod. Check the parts and renew if necessary.

**TYPE II**

**Insufficient oil pressure in overdrive position**

Oil level too low.  
Blocked oil strainer.  
Leakage on non-return valve.  
Broken pump plunger return spring.  
Pump plunger binds.

Fill up with oil to the level plug.  
Clean the oil strainer.  
Check the valve and renew defective parts.  
Remove the pump and renew the plunger spring.  
Remove the pump. Clean the plunger and cylinder bore and renew if necessary.  
Check the valve and renew defective parts.  
Place a washer under the relief valve spring if necessary. As a guide in selecting a washer of suitable thickness it can be taken that a thickness of 0.1 mm (.004") alters the pressure by about 1 kg/cm<sup>2</sup> (14 lb/sq.in.).  
Remove and clean the ball and valve rod. Check the parts and renew if necessary.

Defective relief valve.

Operating valve ball does not seal against valve rod seat.

1. Pump roller
2. Pump plunger
3. Pump plunger spring
4. Solenoid lever
5. Pump body
6. Non-return ball
7. Non-return body
8. Non-return valve spring
9. Rubber ring
10. Relief valve body
11. Relief valve spring
12. Relief valve plunger
13. Solenoid operating lever
14. Operating piston
15. Solenoid armature
16. Operating valve rod (X-ray view)
17. Solenoid
18. Piston seal
19. Thrust bearing retainer
20. Rear casing
21. Speedometer pinion bush
22. Speedometer pinion
23. Output shaft
24. Coupling flange
25. Oil seal
26. Output shaft support bearing
27. Thrust washer
28. Spacer
29. Speedometer driving gear
30. Ball bearing
31. Needle bearing
32. Thrust washer
33. Uni-directional clutch rollers
34. Uni-directional clutch
35. Retaining washer
36. Planet gear
37. Needle bearing
38. Clutch member outer lining
39. Brake ring
40. Locking pin
41. Clutch sliding member
42. Shaft
43. Planet carrier
44. Sunwheel
45. Ball bearing
46. Front casing
47. Operating valve spring (X-ray view)
48. Thrust plate
49. Breather
50. Operating valve spring plunger (X-ray view)
51. Operating valve ball (X-ray view)
52. Clutch return spring
53. Bush
54. Bridge piece
55. Cam
56. Extension casing
57. Input shaft (gearbox mainshaft)
58. Gearbox rear cover

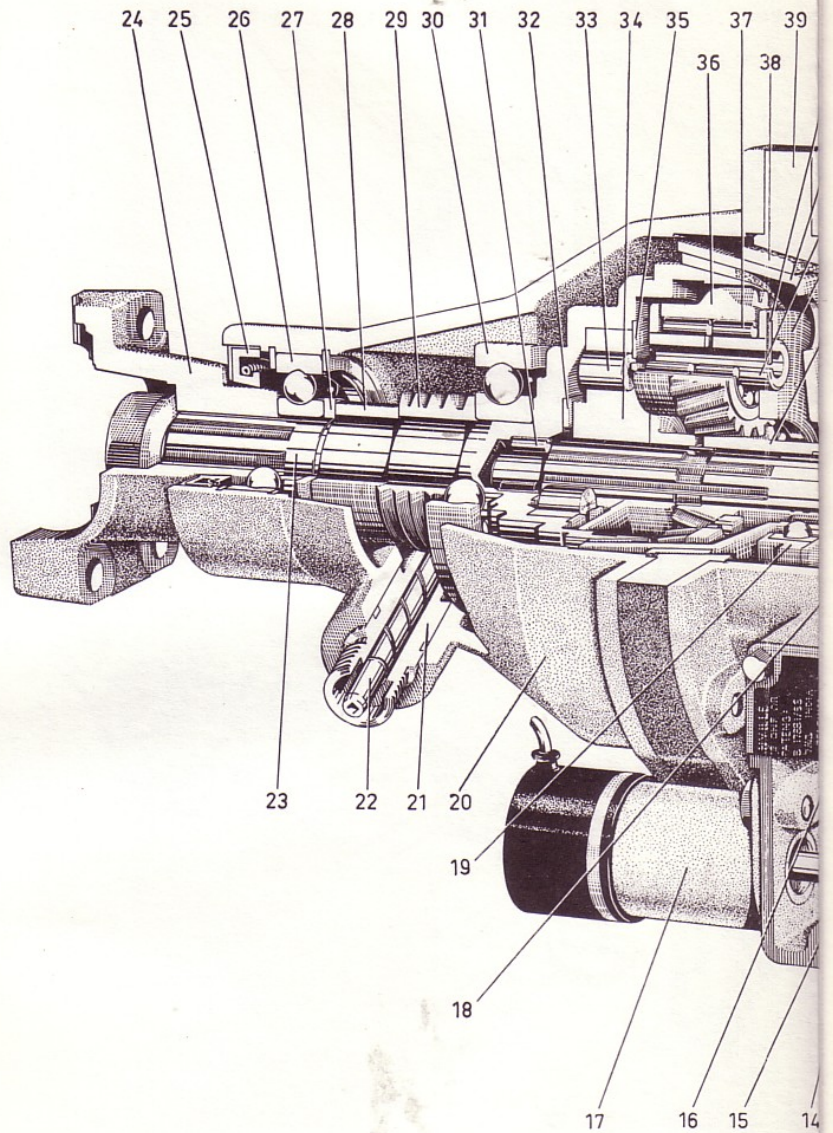
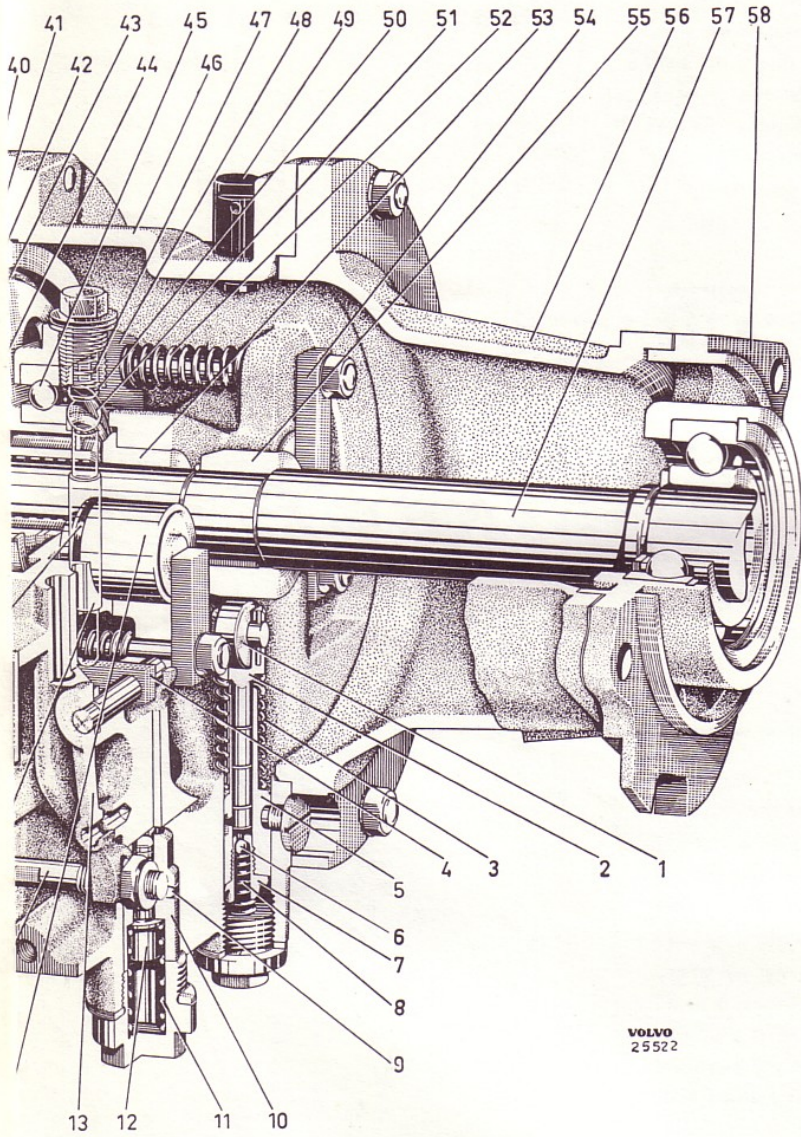


Illustration A. Overdrive



unit, early production

1. Top water pump  
2. Pump pin  
3. Pump pin  
4. Solenoid valve  
5. Pump body  
6. Piston  
7. Piston pin  
8. Piston pin  
9. Piston pin  
10. Piston pin  
11. Piston pin  
12. Piston pin  
13. Piston pin  
14. Piston pin  
15. Piston pin  
16. Piston pin  
17. Piston pin  
18. Piston pin  
19. Piston pin  
20. Piston pin  
21. Piston pin  
22. Piston pin  
23. Piston pin  
24. Piston pin  
25. Piston pin  
26. Piston pin  
27. Piston pin  
28. Piston pin  
29. Piston pin  
30. Piston pin  
31. Piston pin  
32. Piston pin  
33. Piston pin  
34. Piston pin  
35. Piston pin  
36. Piston pin  
37. Piston pin  
38. Piston pin  
39. Piston pin  
40. Piston pin  
41. Piston pin  
42. Piston pin  
43. Piston pin  
44. Piston pin  
45. Piston pin  
46. Piston pin  
47. Piston pin  
48. Piston pin  
49. Piston pin  
50. Piston pin  
51. Piston pin  
52. Piston pin  
53. Piston pin  
54. Piston pin  
55. Piston pin  
56. Piston pin  
57. Piston pin  
58. Piston pin

1. Pump roller
2. Pump plunger
3. Pump plunger spring
4. Solenoid operating lever
5. Pump body
6. Non-return ball
7. Non-return body
8. Non-return valve spring
9. O-ring
10. Relief valve body
11. Relief valve spring
12. Relief valve plunger
13. Solenoid operating lever
14. Operating piston
15. Solenoid armature
16. Operating valve rod (X-ray view)
17. Piston seal
18. Solenoid
19. Thrust bearing retainer
20. Rear casing
21. Speedometer pinion bush
22. Speedometer pinion
23. Ball bearing
24. Thrust washer
25. Output shaft
26. Coupling flange
27. Oil seal
28. Ball bearing
29. Spacer
30. Speedometer driving gear
31. Needle bearing
32. Thrust washer
33. Uni-directional clutch rollers
34. Uni-directional clutch
35. Oil thrower
36. Circlip
37. Oil catcher
38. Planet gear
39. Needle bearing
40. Clutch member outer lining
41. Brake ring
42. Locking pin
43. Clutch sliding member
44. Shaft
45. Planet carrier
46. Sunwheel
47. Ball bearing
48. Front casing
49. Operating valve spring (X-ray view)
50. Thrust plate
51. Breather
52. Operating valve spring plunger (X-ray view)
53. Operating valve ball (X-ray view)
54. Clutch return spring
55. Bush
56. Bridge piece
57. Cam
58. Extension casing
59. Input shaft (gearbox mainshaft)
60. Gearbox rear cover

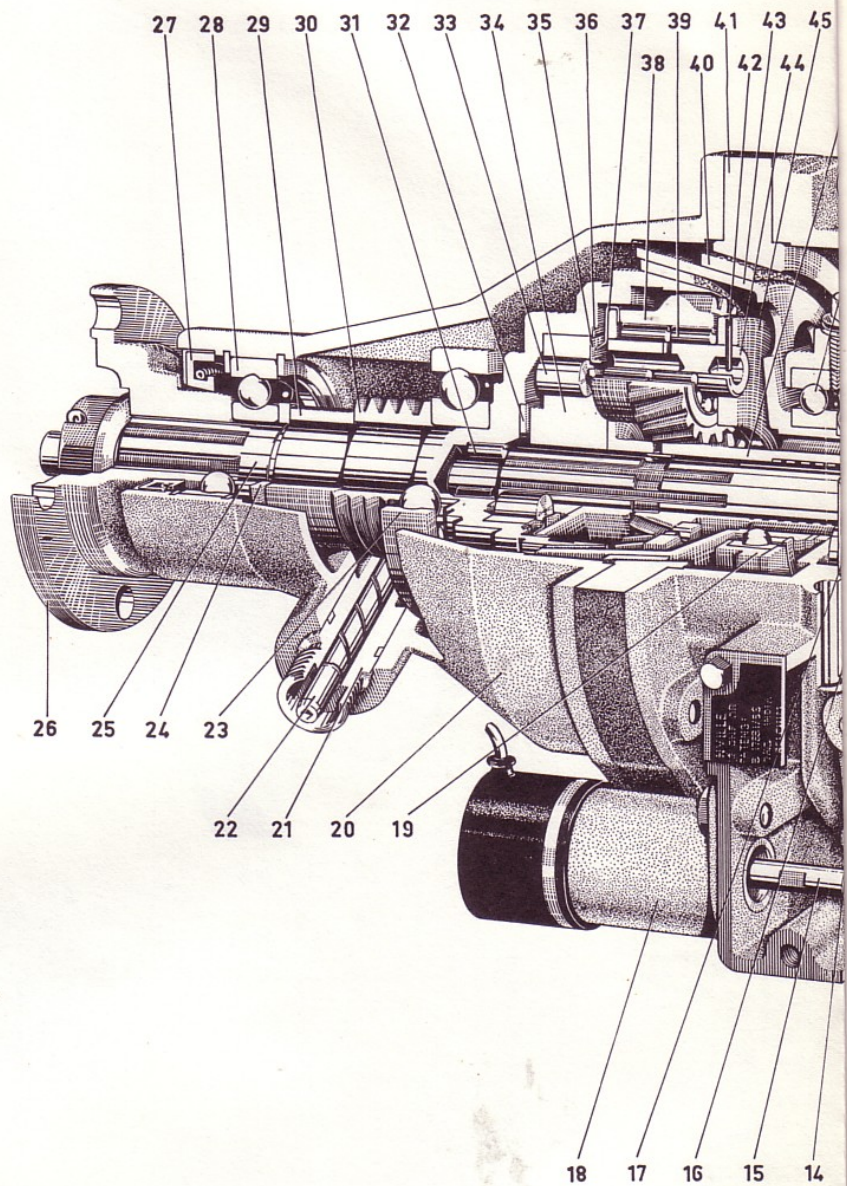
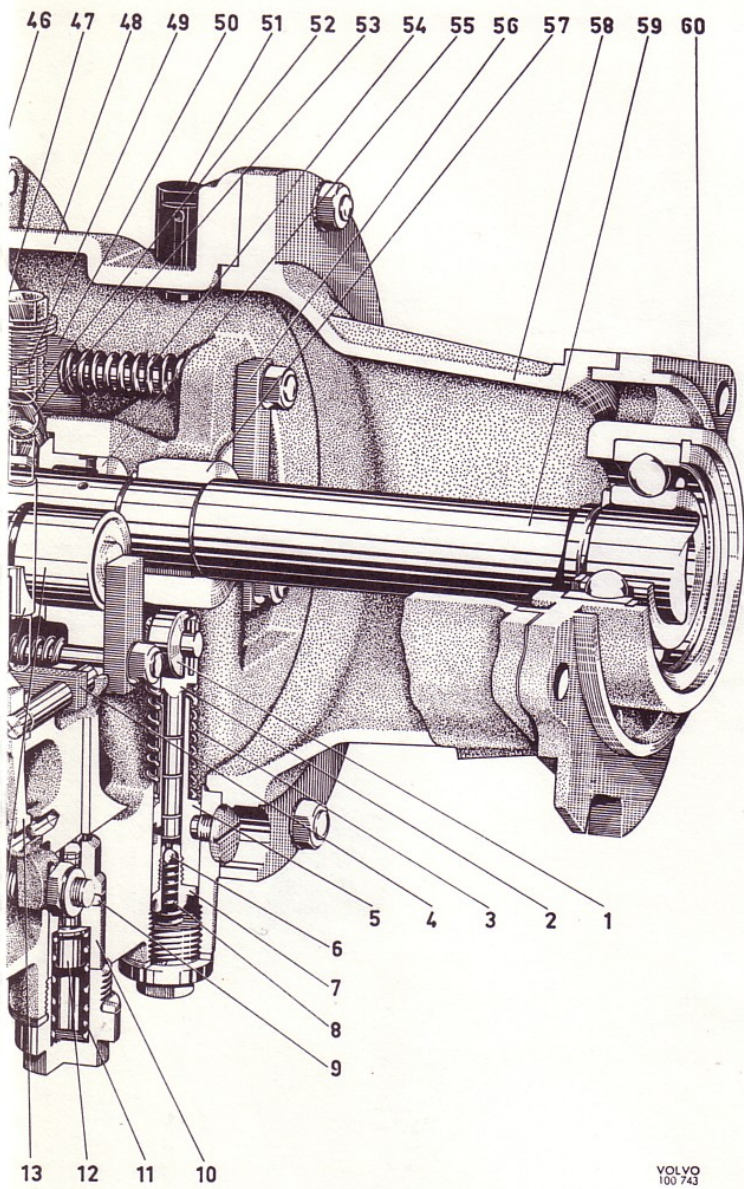


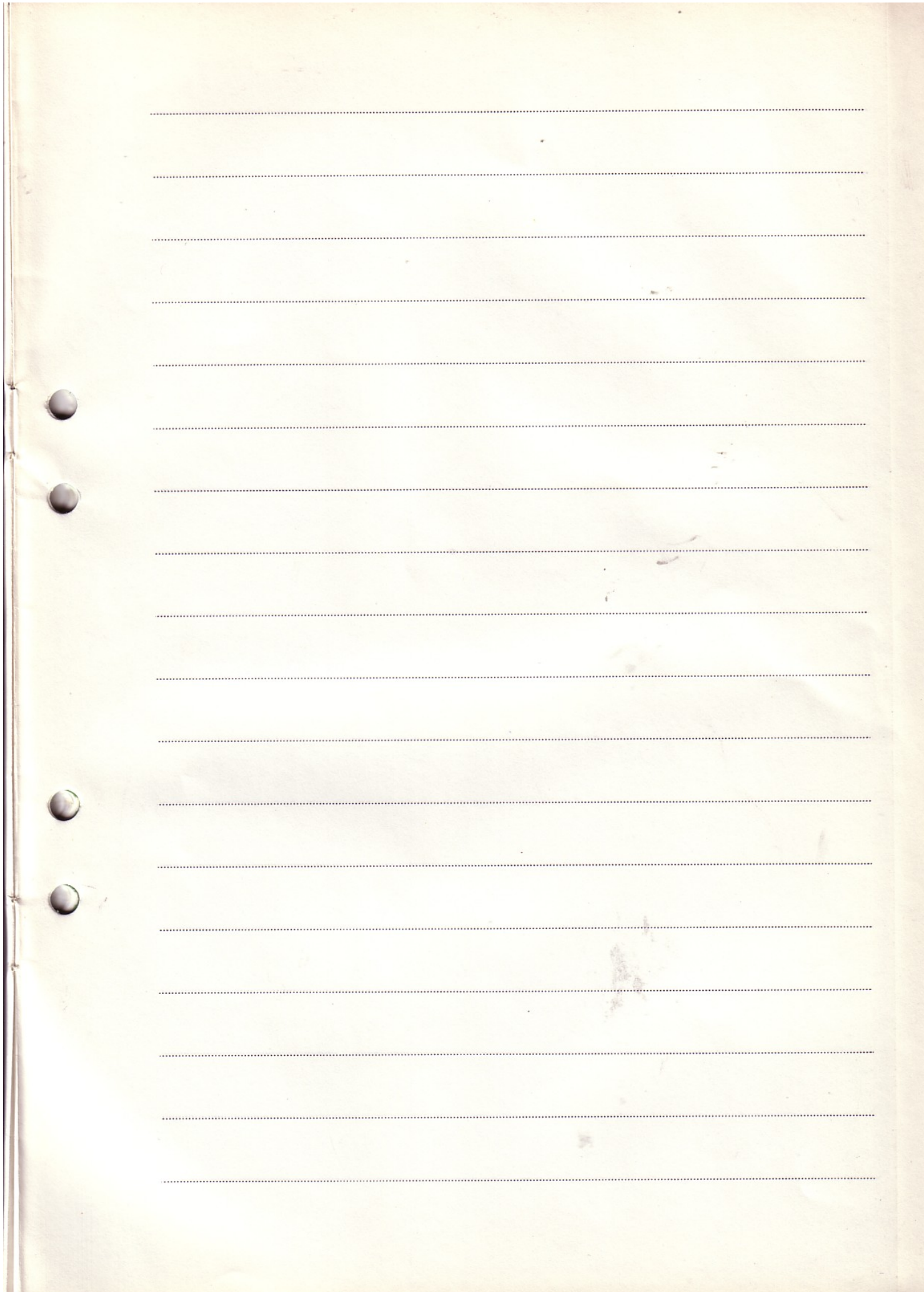
Illustration B. Overdrive un

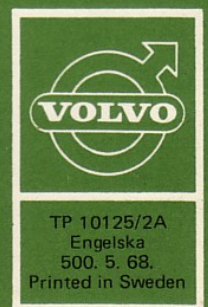


VOLVO  
100 743

it, late production

1. Oil cap  
2. Oil filter  
3. Oil pump  
4. Oil pump drive gear  
5. Oil pump gear  
6. Oil pump housing  
7. Oil pump shaft  
8. Oil pump bearing  
9. Oil pump seal  
10. Oil pump cover  
11. Oil pump gasket  
12. Oil pump nut  
13. Oil pump bolt  
14. Oil pump washer  
15. Oil pump lock washer  
16. Oil pump lock nut  
17. Oil pump lock bolt  
18. Oil pump lock nut  
19. Oil pump lock bolt  
20. Oil pump lock nut  
21. Oil pump lock bolt  
22. Oil pump lock nut  
23. Oil pump lock bolt  
24. Oil pump lock nut  
25. Oil pump lock bolt  
26. Oil pump lock nut  
27. Oil pump lock bolt  
28. Oil pump lock nut  
29. Oil pump lock bolt  
30. Oil pump lock nut  
31. Oil pump lock bolt  
32. Oil pump lock nut  
33. Oil pump lock bolt  
34. Oil pump lock nut  
35. Oil pump lock bolt  
36. Oil pump lock nut  
37. Oil pump lock bolt  
38. Oil pump lock nut  
39. Oil pump lock bolt  
40. Oil pump lock nut  
41. Oil pump lock bolt  
42. Oil pump lock nut  
43. Oil pump lock bolt  
44. Oil pump lock nut  
45. Oil pump lock bolt  
46. Oil pump lock nut  
47. Oil pump lock bolt  
48. Oil pump lock nut  
49. Oil pump lock bolt  
50. Oil pump lock nut  
51. Oil pump lock bolt  
52. Oil pump lock nut  
53. Oil pump lock bolt  
54. Oil pump lock nut  
55. Oil pump lock bolt  
56. Oil pump lock nut  
57. Oil pump lock bolt  
58. Oil pump lock nut  
59. Oil pump lock bolt  
60. Oil pump lock nut





Printed in Sweden, Gotab, Surte 70.6048