



# **SERVICE MANUAL**

**VOLVO 164 1971**

---

## GROUP 44

# AUTOMATIC TRANSMISSION TOOLS

The following special tools are required for repairing the automatic transmission

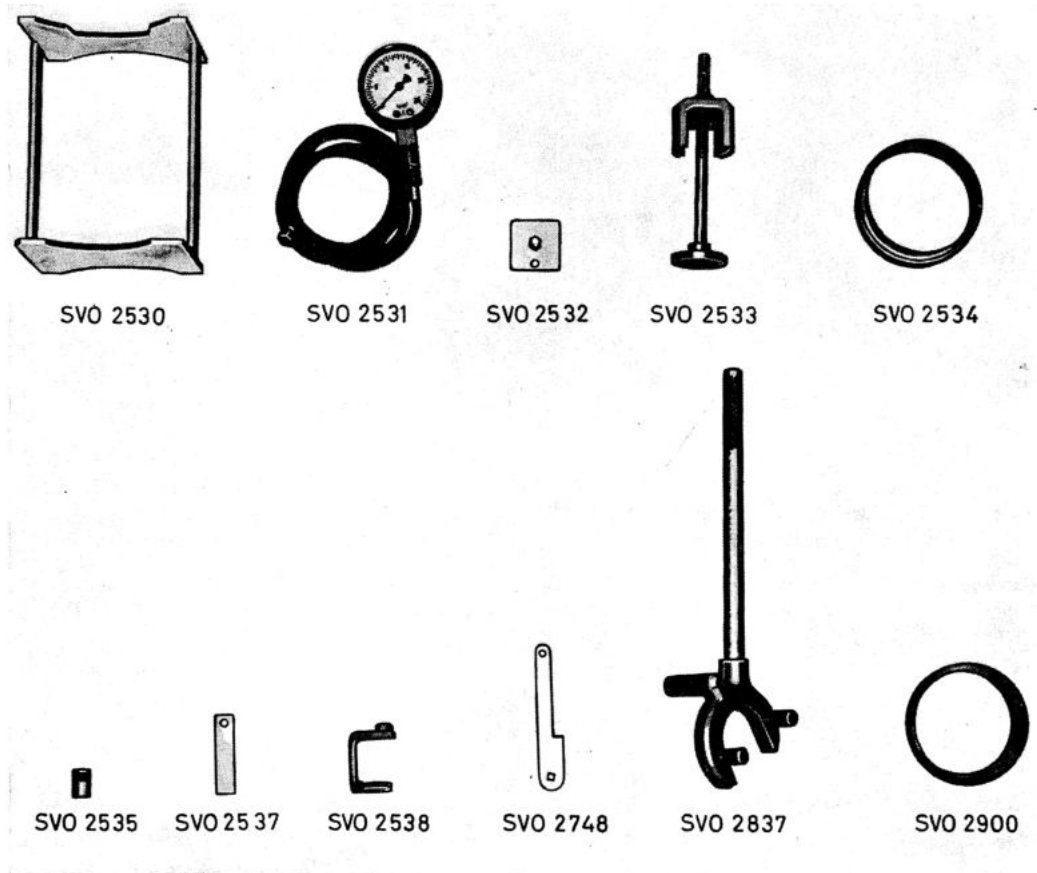

VOLVO  
105438

Fig. 4-58 Special tools

SVO 2530 Fixture for dismantling and assembling the transmission.  
SVO 2531 Manometer complete with hose and connection for checking the oil pressure.  
SVO 2532 Attaching plate for magnetic holder when measuring end float of input shaft.  
SVO 2533 Press tool for compressing clutch when removing and fitting the snap ring.  
SVO 2534 Ring for fitting piston in rear clutch.

SVO 2535 5/16" square socket for adjusting rear brake band.  
SVO 2537 Spacer for adjusting front brake band.  
SVO 2538 Spanner for locknut on contact for starter inhibitor and reversing light.  
SVO 2746 Transmission fixture when removing and fitting, see Fig. 4-76.  
SVO 2748 Dynamometric wrench for adjusting front brake band.  
SVO 2837 Counterhold for flange.  
SVO 2900 Ring for fitting piston in front clutch (used together with SVO 2533)

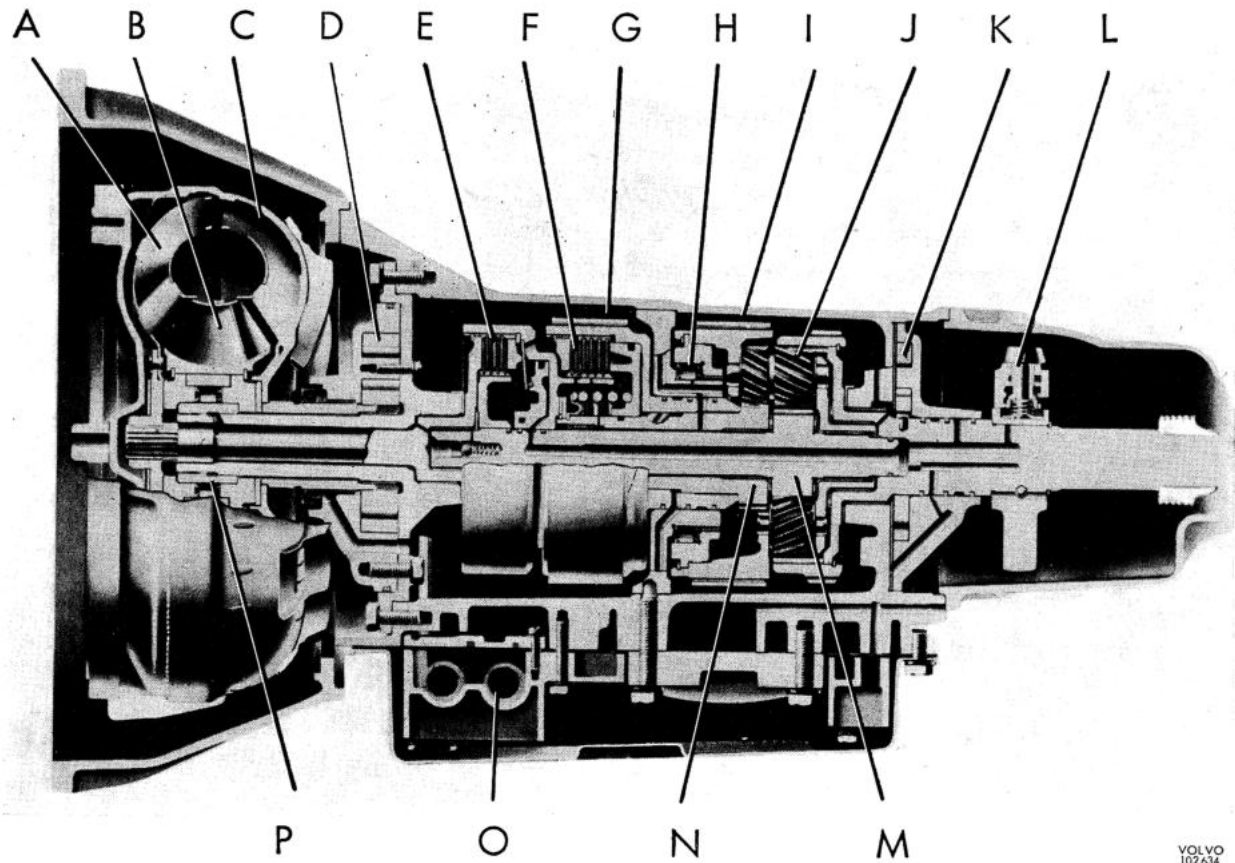

VOLVO  
102634

Fig. 4-59. Sectioned view of the transmission

- |                       |                              |                       |                                |
|-----------------------|------------------------------|-----------------------|--------------------------------|
| A. Turbine            | E. Front clutch              | I. Rear brake band    | M. Reverse sun gear            |
| B. Stator             | F. Rear clutch               | J. Planetary gear set | N. Forward sun gear            |
| C. Impeller and cover | G. Front brake band          | K. Rear pump          | O. Control system              |
| D. Front pump         | H. One-way clutch in gearbox | L. Governor           | P. One-way clutch in converter |

## DESCRIPTION

The Volvo automatic transmission for cars is of Borg-Warner manufacture, type 35. It consists of two main components:

1. A three-element hydrokinetic torque converter

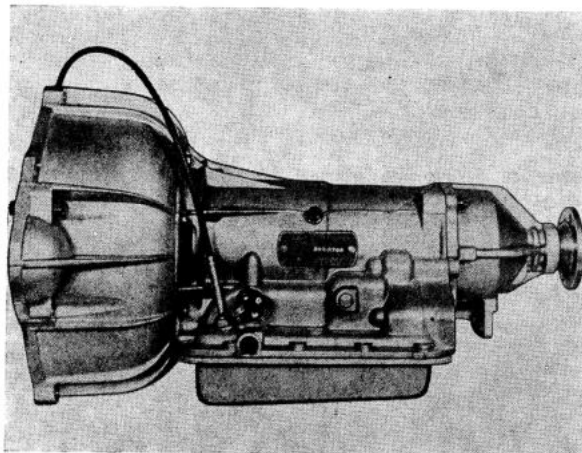

VOLVO  
105376

Fig. 4-60. The Borg-Warner Automatic Transmission type 35

coupling capable of torque multiplication at an infinitely variable rate between 2:1 and 1:1.

2. A hydraulically operated gearbox comprising a planetary gear set with a valve system which automatically selects a suitable gear in relation to the speed of the car and position of the accelerator pedal.

There is also a selector control with positions "L", "D", "N", "R" and "P", see Fig. 4-61.

### THE TORQUE CONVERTER

The torque converter serves both as a clutch and as an extra (hydraulic) gear between the engine and gearbox. It provides a means of obtaining smooth application of engine power to the driving wheels and additional engine torque multiplication to the 1st and 2nd gears of the gearbox. The converter also provides extreme low-speed flexibility when the gearbox is in 3rd gear and, due to the ability of multi-

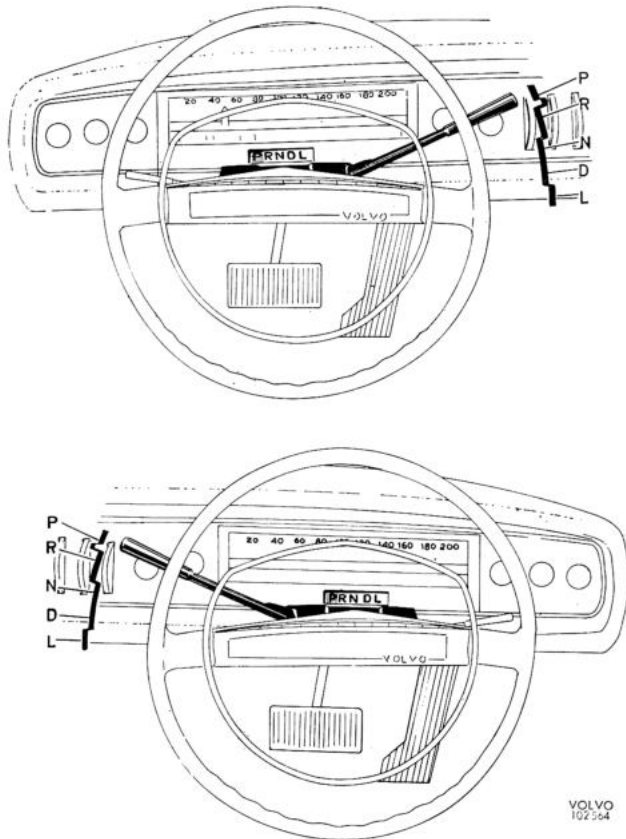

Fig. 4-61. Selector lever positions

plying engine torque, it provides good acceleration from very low road speed without having to resort to a downshift in the gearbox.

The converter consists of three main components — an impeller connected to the engine crankshaft, a turbine connected to the input shaft of the gearbox, and a stator mounted on a sprag-type one-way clutch supported on a fixed hub projecting from the gearbox case.

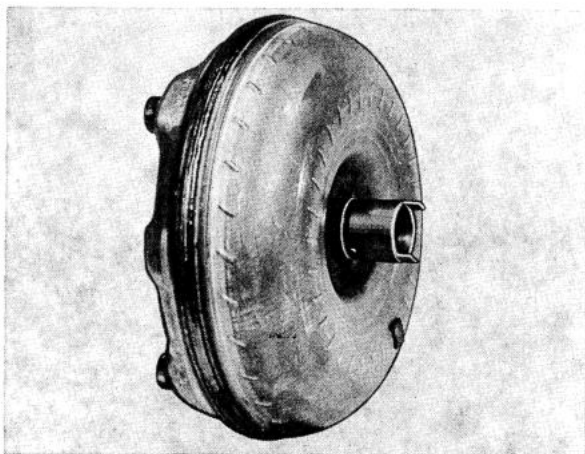

Fig. 4-62. The converter

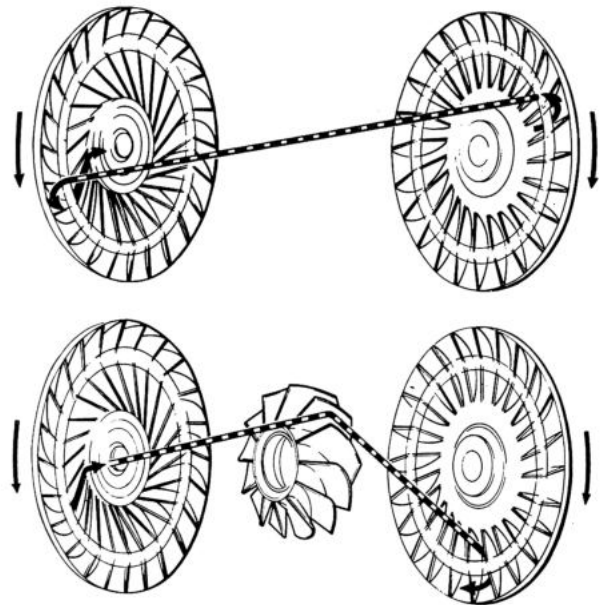

Fig. 4-63. Function of converter

The converter functions as follows:

The impeller is rotated by the engine and converts the engine power into hydrokinetic energy. The fluid flows from the impeller vanes to the turbine vanes and returns to the impeller through the stator vanes, see Fig. 4-63. The curvature of the various vanes is so designed that when a speed differential exists between the impeller and the turbine, the angle of the fluid flow from the turbine is changed by the stator vanes in such a way that the discharge of fluid from the stator assists in driving the impeller. Under such conditions, torque multiplication occurs and varies from 2:1 when the turbine is stalled (i.e. when, with any of the driving ranges selected, the vehicle is held stationary and the engine is operating at maximum throttle opening) to 1:1 when the turbine reaches a speed approximately 90 % of that of the impeller. When this speed differential between the impeller and turbine is achieved, the fluid flow angle from the turbine is such that the stator is driven in the same direction as the turbine and the impeller. Under these circumstances, the converter becomes a fluid flywheel or coupling and there is no torque multiplication.

## GEARBOX

The gearbox consists of a mechanical power transmission system — planetary gear, two clutches, two brake bands and a one-way clutch — and a hydraulic system — front and rear pump, centrifugal governor and a control valve system which regulates the fluid pressure and directs the fluid to the various gearbox components.

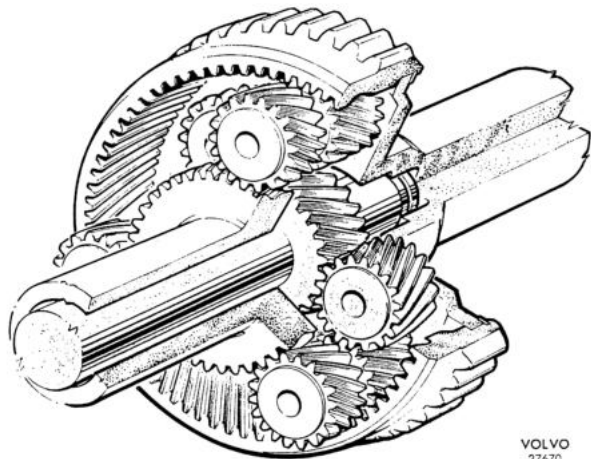

Fig. 4-64. Planetary gear

VOLVO  
27670

## MECHANICAL POWER TRANSMISSION SYSTEM

### PLANETARY GEAR

The planetary gear set consists of two sun gears, two sets of pinions, a pinion carrier and a ring gear, see Fig. 4-64. Helical involute tooth forms are used throughout. In all forward gears, power enters through the forward sun gear; in reverse, power enters through the reverse sun gear. Power leaves the gear set by the ring gear. The pinions are used to transmit power from the sun gears to the ring gear. In reverse, a single set of pinions is used which causes the ring gear to rotate in the opposite direction to the sun gear. In forward gears, a double set of pinions is used to cause the ring gear to rotate in the same direction as the sun gear. The carrier locates the pinions in their correct positions relative to the two sun gears and the ring gear (and also forms a reaction member in certain conditions). The various mechanical ratios of the gear set are obtained by the engagement of hydraulically operated multi-disc clutches and brake bands.

### CLUTCHES

The clutches, see Fig. 4-65, consist of multi-disc units operated by hydraulic pistons. In all forward gears the front clutch connects the converter to the forward sun gear; for reverse, the rear clutch connects the converter to the reverse sun gear.

### BRAKE BANDS

Brake bands, operated by hydraulic servos, hold elements of the gear set stationary to effect an output speed reduction and a torque increase. In "lock-up", the rear band holds the pinion carrier stationary

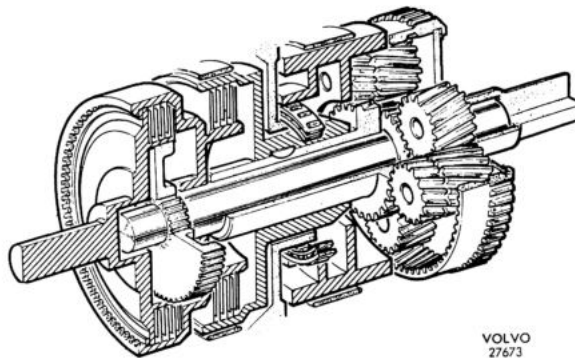

Fig. 4-65. Planetary gear, clutches and brake bands

VOLVO  
27673

and provides the 1st gear ratio of 2.39:1 and, in reverse, a ratio of 2.09:1. The front band holds the reverse sun gear stationary to provide the 2nd gear ratio of 1.45:1.

### ONE-WAY CLUTCH

In the drive position "D", a one-way clutch is used in place of the rear band to prevent the pinion carrier from turning opposite to engine rotation, thus also providing a 1st gear ratio of 2.39:1. This one-way clutch, allowing the gearbox to freewheel in 1st gear, provides smooth ratio changes from 1st to 2nd and vice versa.

### OIL COOLER

The automatic gearbox is connected to an oil cooler. This is housed in the bottom tank of the engine radiator and is connected as shown in Fig. 4-67. The oil cooler is connected to the nipple (Fig. 4-66) on the right-hand side of the gearbox.

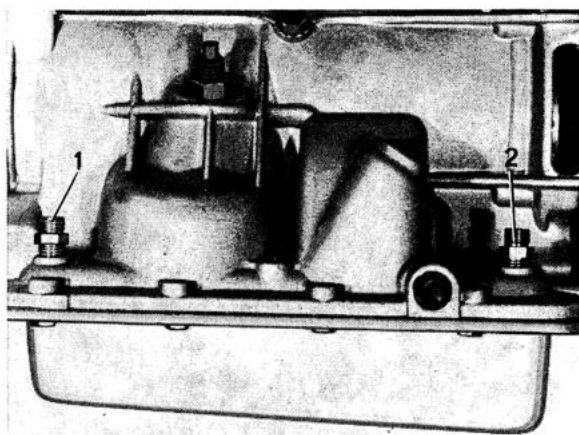

Fig. 4-66. Oil cooler connection  
1 and 2. Connection nipples for oil cooler

VOLVO  
10498P

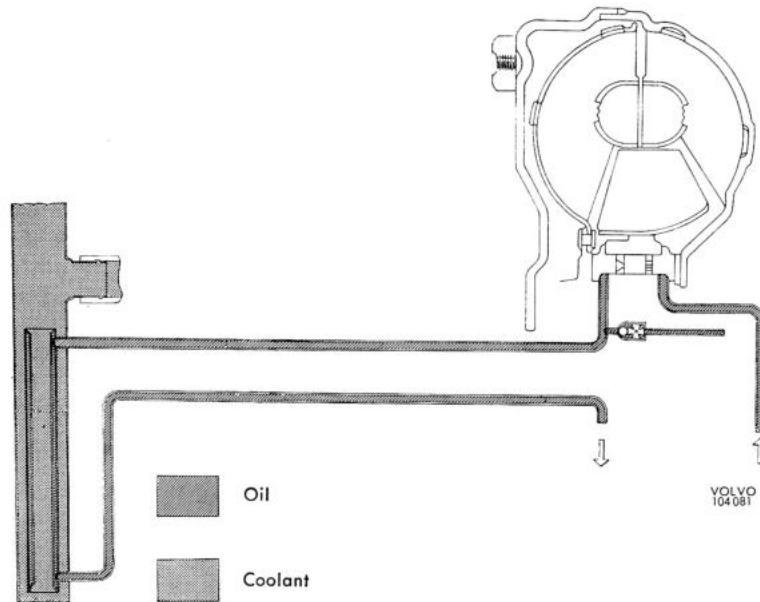

Fig. 4-67. Principle of operation for oil cooler

## REPAIR INSTRUCTIONS

When carrying out any work on the vehicle, the selector lever should be in position "P".

Provided the transmission is operating satisfactorily, the car may be towed in position "N", on condition that the gearbox is properly adjusted and the fluid level is correct. **If the transmission is inoperative, the propeller shaft should be disconnected before starting towing.**

The control system of the automatic transmission is manufactured with the same degree of precision and accurate fits as the injection equipment of a Diesel engine. Fluid circulates through the converter, transmission gearbox and control system. **It is therefore necessary to observe the utmost cleanliness when carrying out any work on the transmission.**

### WORK WHICH CAN BE CARRIED OUT WITHOUT REMOVING THE TRANSMISSION SUPPLEMENT

#### CHECKING THE FLUID LEVEL

Normally oil changing is only required when the gearbox has been reconditioned. However, the oil level should be checked every 10 000 km (6 000 miles). When checking the oil level, the car should be on a level surface. Move the selector to position "P" and let the engine idle. The filling pipe with dipstick is located in front of the bulkhead on the right-hand side of the engine. Pull up the dipstick, and wipe it with nylon cloth, paper or chamois leather. Fluffy rags must not be used. Insert the dipstick, then pull

it up and note the oil level, see Fig. 4-68. **N.B. There are different oil level marks for a warm or cold gearbox.** When the gearbox is warm, after the car has been driven about 5—7 miles (8—10 km), the upper area (3 and 4, Fig. 4-68) applies. The lower area (1 and 2) applies when the gearbox is cold. The text on the dipstick also mentions this difference.

If necessary, top up with oil to the "Max" mark. Do not exceed this mark, otherwise the gearbox can become overheated. The difference between the "Min" and "Max" mark is about 1 pint (0.5 litre). Use an oil which is approved as "Automatic Transmission Fluid, Type F".

If topping up with oil is required often, there must be leakage, which should be attended to immediately.

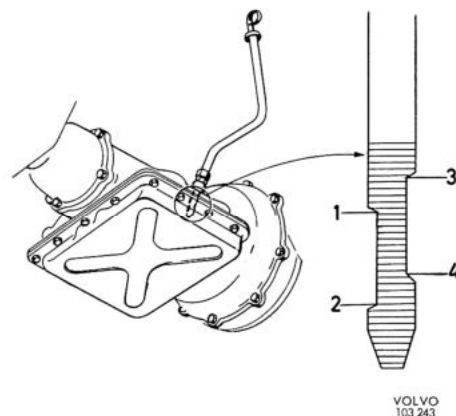

Fig. 4-68. Checking the oil level

1. Max. oil level, cold gearbox
2. Min. oil level, cold gearbox
3. Max. oil level, gearbox run warm
4. Min. oil level, gearbox run warm

## REMOVING AND FITTING THE CONTROL SYSTEM

1. Jack up and place blocks under the vehicle. Drain off the oil into a vessel which is absolutely clean. See Fig. 4-75.  
N.B. The oil may be very hot and cause burns if contact is made with the skin.
2. Release the bolts for the oil sump and remove the sump. Carefully remove the oil pipes (Fig. 4-78).
3. Release the throttle cable from the cam. Remove the three bolts, see Fig. 4-79, which secure the control system to the gearbox casing. Remove the control system straight downwards so that it releases from the oil pipes at the front end.
4. Make sure that the oil pipes are in position on the front pump body. Place the control system in position and secure it with the three bolts, see Fig. 4-79.
5. Fit the throttle cable to the cam. Mount the oil pipes as shown in Fig. 4-78. Check that the magnetic element lies in the oil sump and fit the sump. Use a new gasket. Coat the threads on the oil drain plug with sealing fluid 277961 and then fit the plug.
6. Lower the vehicle, fill with oil.

## ADJUSTING THE SELECTOR CONTROLS

1. Disconnect the pull rod from the lever on the selector shaft. Set the selector lever to "N".
2. Set the lever on the transmission to the central position. Adjust the length of the pull rod so that the pin can be pushed easily through the yoke and lever.
3. Check the setting by noting the distance to the selector lever in "N" and "D" positions. The clear-

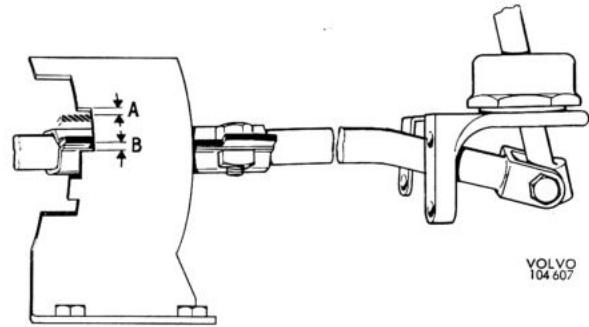

Fig. 4-69. Adjusting selector controls  
A = B

ance should be the same in both positions, see Fig. 4-69.

4. Check that the pointer for the gear positions points correctly on the scale. If not, adjust the cable sleeve at the indicator (Fig. 4-123).
5. Check that the output shaft is locked with the control lever in position "P".

## ADJUSTING THE THROTTLE CABLE

Correct adjustment of this cable is most important for satisfactory operation of the transmission. There are three different methods. **Adjust first in accordance with A, see Fig. 4-70. Method B is to be applied if the transmission is not functioning satisfactorily, and method C when replacing the cable.**

1. Check that engine idling speed is correctly adjusted and that the inner cable and outer cable are correctly attached.
2. Screw up the threaded sleeve until it almost lies against the stop (for vehicles with single carburettor), and 1/32" (1 mm) from the stop for vehicles with twin carburettors, the stop being crimped on to the cable.

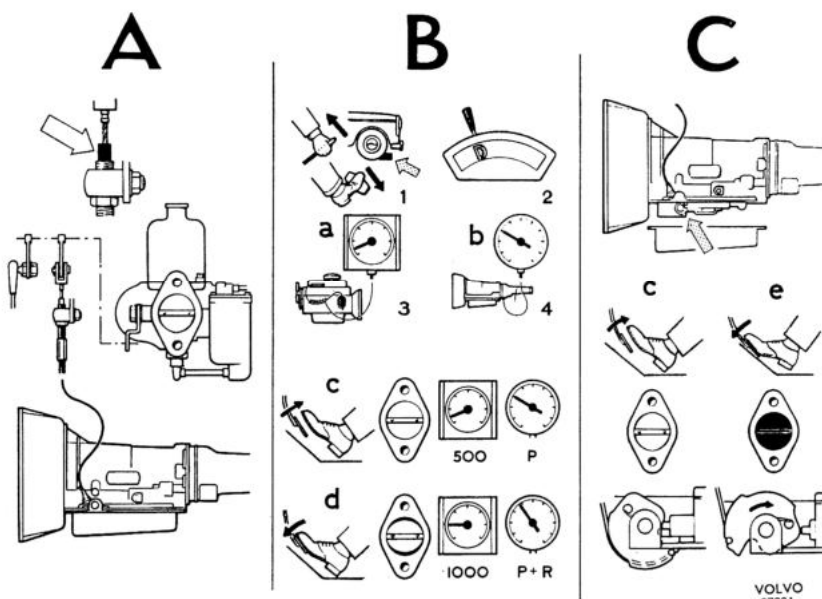
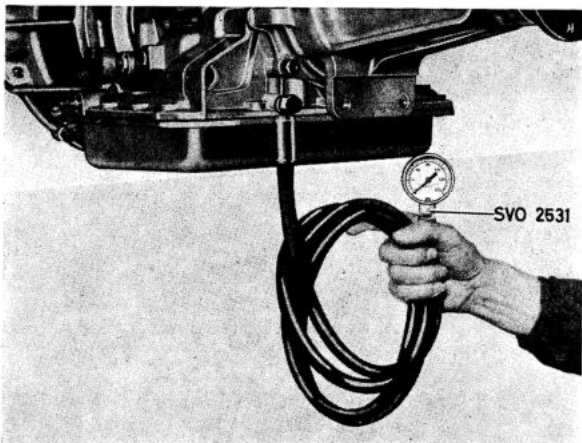

Fig. 4-70. Adjusting throttle cable

1. Check the wheels and apply the brakes
  2. Select position "D"
  3. Connect a revolution counter (a)
  4. Connect a pressure gauge (b)
  - c. Measure pressure (P) at 500 r.p.m.
  - d. Measure pressure (P+R) at 1000 r.p.m. R. Should be 1.1—1.4 kp/cm<sup>2</sup> (15—20 p.s.i.)\*
- Adjust the cam in gearbox
    - Accelerator pedal in idling position
    - Accelerator pedal fully depressed

3. With the accelerator pedal fully depressed, check that:
    - a. the carburettor lever is at the full open stop.
    - b. the line pressure at converter stall speed amounts to at least 160 p.s.i. (11 kg/cm<sup>2</sup>).
  - B. If the cable stop has been damaged or moved, the cable must be adjusted as follows:
    1. Connect a tachometer to the engine and pressure meter to the transmission as shown in Fig. 4-71.
    2. Chock the wheels and apply the brakes. Start the engine and move the lever to "D". Read off the pressure at 500 and 1000 r.p.m. At 1000 r.p.m. the gauge to the transmission as shown in Fig. 4-71. pressure should be 15—20 p.s.i. (1.1—1.4 kp/mm<sup>2</sup>)\* higher than at 500 r.p.m. If the pressure rise is less than 15 p.s.i. (1.1 kg/cm<sup>2</sup>), the effective length of the outer cable should be increased by means of the adjuster. Conversely, if the rise is more than 20 p.s.i. (1.4 kp/cm<sup>2</sup>) the effective length of the outer cable should be decreased.
- N.B. On vehicles with an exhaust emission control system, it may be more suitable to measure the pressure at 700 and 1200 r.p.m. The pressure increase also in this case should be 15—20 p.s.i. (1.1—1.4 kp/cm<sup>2</sup>)\*
- C. If a new cable has to be fitted, the transmission oil pan must be removed. In this event it is often simpler to adjust the cable by observing the movement of the cam in relation to accelerator pedal movement as follows:
    1. With the accelerator pedal fully released and the carburettor lever at the idling stop, the heel of the cam should contact the full diameter of the downshift valve, with all the slack of the inner cable taken up.
    2. With the accelerator pedal fully depressed and the carburetor lever at the full open stop, the

\* AS5—35 EN with effect from serial No. 1829: 25—30 p.s.i. (1.8—2.1 kp/cm<sup>2</sup>).



VOLVO  
400 062

Fig. 4-71. Connecting pressure gauge

constant radius area of the cam should be the point of contact with the downshift valve.

- Note:**
1. The cable is pre-lubricated with silicon or molybdenum disulphide lubricant and must not be oiled.
  2. Ensure at all times that the outer cable is correctly located in the adjuster.

### ADJUSTING THE STARTER INHIBITOR SWITCH

The starter inhibitor switch has two terminals for the starter inhibitor circuit, the function of which is to prevent the engine from being started with the selector in any other position than "N" or "P". There are also two terminals for the reversing light. It is very important that this switch is correctly adjusted, since if the engine can be started in any of the driving positions, the car can easily be set in motion unintentionally and possibly cause an accident. The switch is adjusted as follows:

1. First check that the selector control is correctly adjusted. Move the selector to "D".
2. Slacken the locknut for the switch with the help of the special spanner. Screw out the switch until it is only held by a couple of threads.
3. Connect a control lamp to the reversing light terminals as shown in Fig. 4-72 "A". Screw in

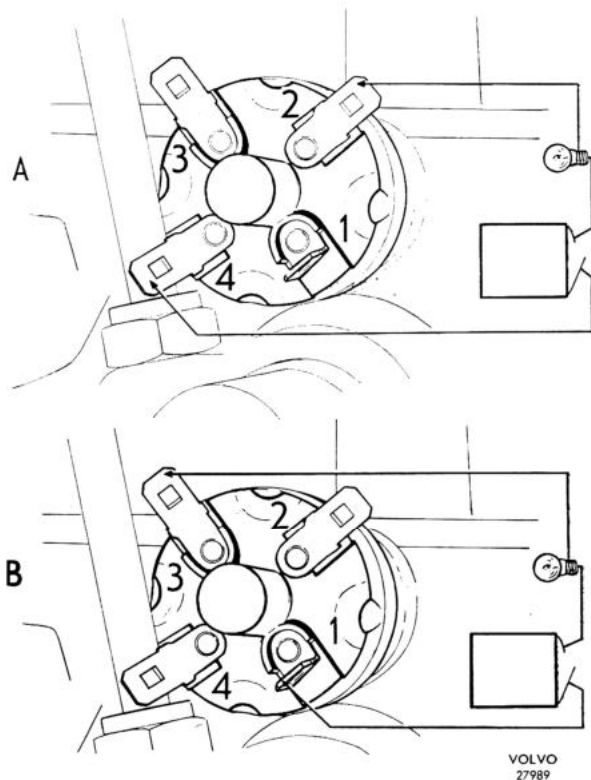

VOLVO  
27989

Fig. 4-72. Adjusting starter inhibitor

- A. Bulb connected to reversing light contacts
- B. Bulb connected to starter inhibitor contacts

the switch until the lamp goes out. Mark this position on the housing and switch with a pencil.

4. Connect the control lamp to both the other terminals, Fig. 4-72 "B". Screw in the switch until the lamp lights again and then mark the switch again. Then screw back the switch to halfway between both the marks. Lock with the locknut. Connect the leads.
5. Apply the brakes and chock the wheels. Check that the engine can only be started with the selector lever in "N" or "P". Move the selector lever to "R" and check that the reversing light lights up when the lighting switch is switched on.

### ADJUSTING THE REAR BRAKE BAND

When adjusting this band in the car, a hole has been introduced in the body tunnel, which is accessible after the mats have been moved to one side and the rubber removed. Otherwise adjusting is carried out as follows:

1. Slacken the locknut for the adjusting screw.
2. Use the special socket SVO 2535 and connect the torque wrench to the adjusting screw, see Fig. 4-73. Tighten the screw to 10 lb.ft. (1.4 kpm). Back off the adjusting screw one turn.
3. Tighten the locknut and fit any parts which have been removed.

### AIR PRESSURE CHECKS

Air pressure checks can be made on the gearbox assembly to determine whether the clutches and brake bands are operating. These checks can be made with the transmission in the car or on the bench. In either event, drain the fluid from the gearbox and remove the oil pan as well as the valve bodies assembly with oil tubes. The air used must be clean and dry.

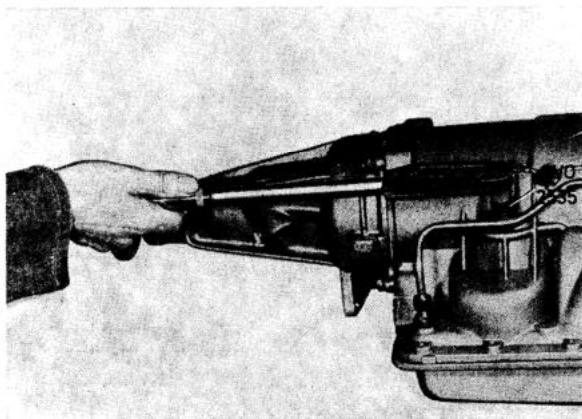

Fig. 4-73. Adjusting rear brake band

If the clutch and bands operate satisfactorily with air pressure, faulty operation of the transmission must be due to malfunction of the hydraulic control system. The valve bodies assembly must then be dismantled, cleaned, inspected and re-assembled.

### FRONT CLUTCH AND GOVERNOR FEED "A"

Apply air pressure to the passage (5) of the transmission case rear wall, see Fig. 4-74. Listen for a thump, indicating that the clutch is functioning. On the bench, also verify by rotating the input shaft with air pressure applied.

If the extension housing has been removed, rotate the output shaft so that the governor weight will be at the bottom of the assembly. Verify that the weight moves inwards with air pressure applied.

### REAR CLUTCH "B"

Apply air pressure to the passage (15) of the transmission case web. On the bench, verify by turning the input shaft that the clutch is functioning. Keep air pressure applied for several seconds to check for leaks. Then listen for a thump indicating that the clutch is releasing when the air pressure is removed.

### FRONT SERVO "C"

Apply air pressure to the hole immediately adjacent to the rear retaining bolt. Observe the movement of the piston pin.

### REAR SERVO "D"

Apply air pressure to the hole on the servo body. Observe the movement of the servo lever.

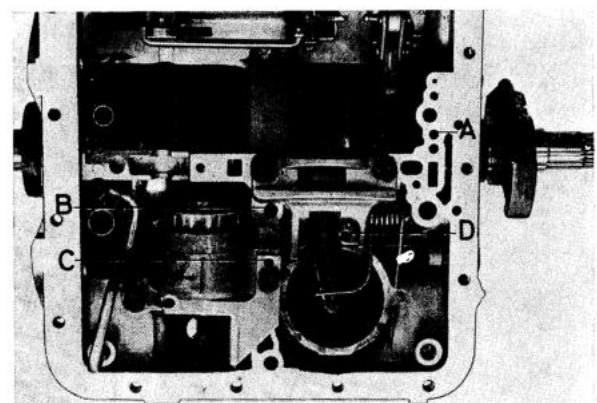

Fig. 4-74. Functioning test with compressed air

- A. Front clutch (5)
- B. Rear clutch (15)
- C. Front servo application
- D. Rear servo

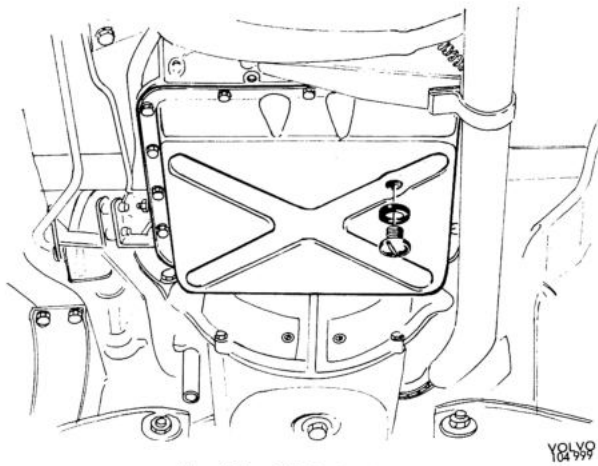

Fig. 4-75. Oil drain plug

## REMOVING GEARBOX WITH CONVERTER

1. Take up the oil dipstick and remove the clamp for the filler pipe. Remove the bracket and the throttle cable from the dashboard and throttle control respectively. Disconnect the exhaust pipe at the flange. Jack up the car and place blocks under the front and rear axles.
2. Drain the oil into a clean container, see Fig. 4-75.  
**N.B. The oil may be very hot and scald if contact is made with the skin.**
3. Place lifting tool SVO 2727 at the rear end of the engine. Hook the lifting hook securely round the exhaust pipe.  
N.B. Observe due care so that the speedometer cable or the electric cables are not damaged. Tighten the nut for the lifting hook until the sling takes the weight off the engine.
4. Disconnect the propeller shaft from the gearbox

- flange. Disconnect the controls from the selector shaft lever as well as the reinforcing bracket under the oil pan.
5. Remove one of the air grilles on the converter casing and unscrew the attaching bolts for the converter. With a spanner on the camshaft pulley bolt turn the crankshaft forwards. The spanner is also used as a counterhold.
  6. Unscrew the nut for the rear engine mounting and remove the cross-member. Disconnect the brackets for the exhaust pipe and the rear engine mounting. Remove the speedometer cable from the gearbox. Release the oil filler pipe.
  7. Lower the engine about 20 mm (0.8"). Observe due care with the battery lead. If any tensions arise, release the lead clamp.
  8. Disconnect the electric cables from the starter inhibitor. Unscrew the screws for the starter inhibitor. Place a jack with fixture SVO 2746 under the gearbox. See Fig. 4-76. Unscrew the attaching bolts for the converter casing. Pull the gearbox backwards and release the guide pin on the converter at the same time. Lower and remove the gearbox.

## DISMANTLING

As a general rule it is advisable to dismantle only those components requiring attention as indicated by road-testing or fault-tracing procedure. Prior to the removal of any components, the outside of the gearbox must be thoroughly washed down with white spirit. A high standard of cleanliness is required when handling or storing components. When dismantling, the gearbox should be inverted and placed on the bench cradle as shown in Fig. 4-77, and special tools used as shown in the service tool list. Treat the various components with great care,

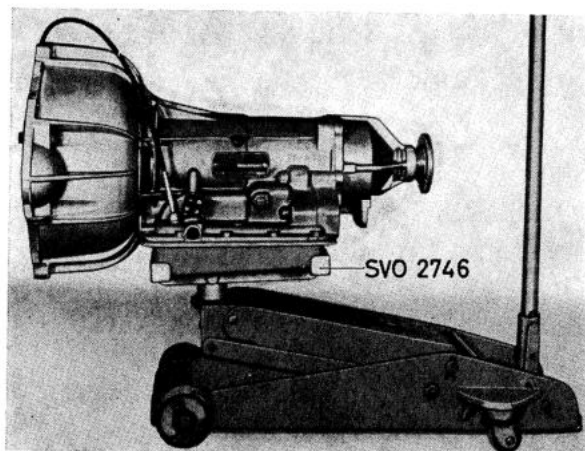

Fig. 4-76. Fixture for transmission

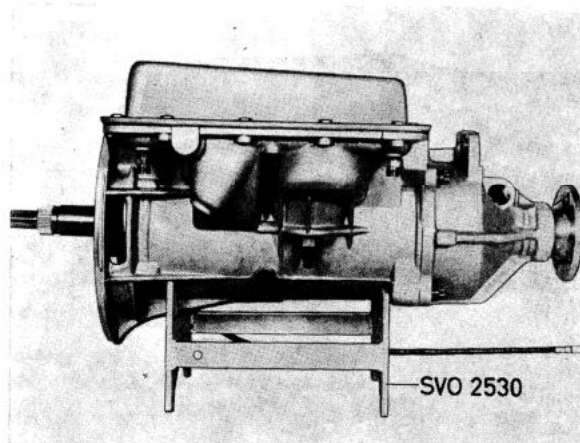

Fig. 4-77. Transmission on bench stand

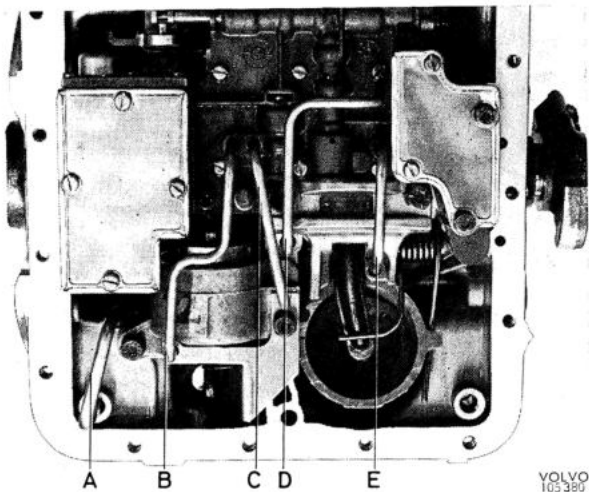

Fig. 4-78. Oil tubes

- A. Converter outlet
- B. Front servo release
- C. Front servo apply
- D. Rear clutch
- E. Rear servo

particularly light-alloy parts. When the gearbox is to be completely dismantled, follow the procedure below.

1. If the converter housing is attached to the gearbox, remove the six bolts and withdraw the converter housing.
2. Unscrew the "Wedglok" screw for the drive flange on the output shaft. Pull out the drive flange and catch the  $\frac{3}{8}$ " flat washer. Loosen and withdraw the rear housing. Remove the speedometer gear.
3. Unscrew the bolts for the oil pan and remove this. Lever out carefully the oil tubes shown in Fig. 4-78.

### THE VALVE BODIES ASSEMBLY

Work on the whole assembly should preferably be carried out in a diesel test-room or in a room with equal standards of cleanliness.

4. Disconnect the downshift valve cable from the downshift valve cam. Unscrew the three screws which retain the valve bodies assembly to the gearbox housing, see Fig. 4-79. Lift the valve bodies assembly straight up so that it releases from the oil tubes at the front end.
5. Unscrew the two screws for the bracket of the downshift valve cam.
6. Remove the two strainers for the front and rear pump respectively.
7. Unscrew from above the screws which retain the upper valve body. Turn the valve bodies assembly round and unscrew the other six screws from underneath.

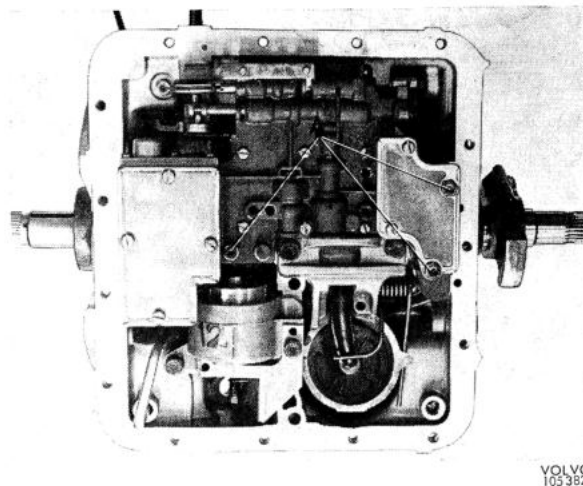

Fig. 4-79. Valve bodies assembly

- A. Attaching screws

8. Unscrew the eight screws which retain the oil tube collector.
9. Unscrew the four screws which retain the governor line plate. Note that two screws are under one of the strainers.
10. Remove the separating plate and then the check valves for the converter, fast 3-2 and front and rear pumps, see Fig. 4-81. Withdraw the manual control valve, see "A", Fig. 4-82.
11. Remove the stops for the throttle valve and the return spring. Then withdraw the downshift valve, spring and throttle valve, see "B", Fig. 4-82.
12. Remove the dowel pin which retains the plug for the modulator valve. Then remove the plug, valve, plunger and spring.

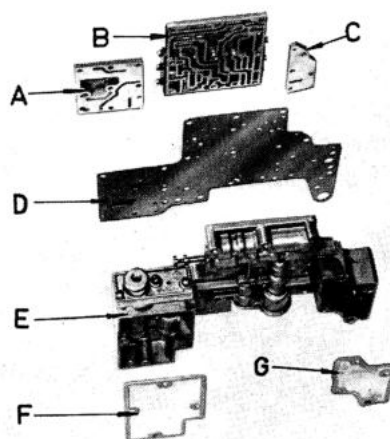
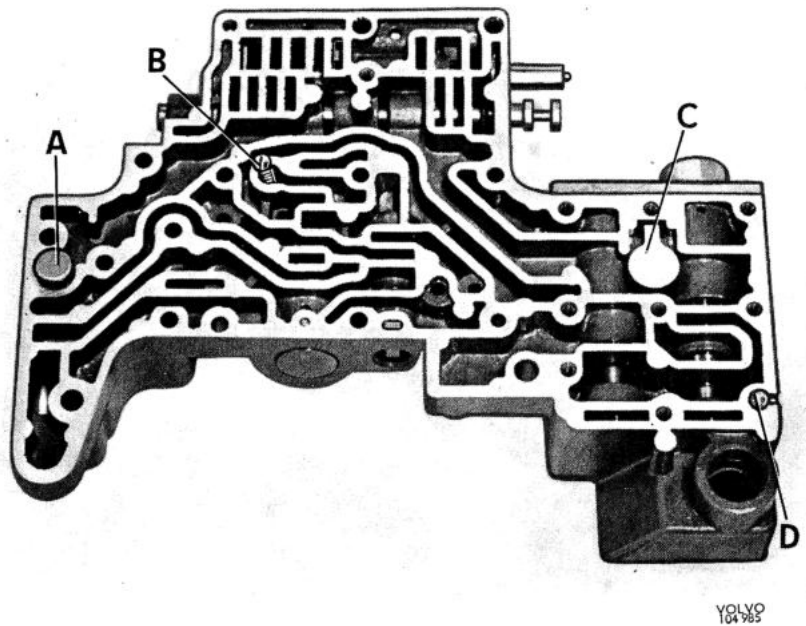

Fig. 4-80. Main components of valve bodies assembly

- A. Oil tube collector
- B. Upper valve body
- C. Governor line plate
- D. Separating plate
- E. Lower valve body
- F. Front pump strainer
- G. Rear pump strainer

Fig. 4-81. Check valves in lower valve body

- A. Rear pump check valve
- B. Check valve for fast 3-2
- C. Front pump check valve
- D. Converter outlet check valve (only R-H drive)



13. Remove the stop for the servo orifice control valve and then the spring and valve.
14. From the manual valve side of the lower valve body, remove the following components: three screws, lower body end plate, primary regulator spring, primary regulator valve sleeve, primary regulator valve, secondary regulator valve spring and secondary regulator valve.

15. Remove the six screws and end plate from the upper valve body, see Fig. 4-83. Remove the following parts from the rear end of the body: shift valve 2—3, inner spring and plunger together with shift valve 1—2. The spring and plunger for shift valve 1—2 are removed in the other direction.

Fig. 4-82. Lower valve body

- A. Manual control valve
- B. Downshift and throttle valve
- C. Primary regulator valve
- D. Secondary regulator valve
- E. Servo orifice control valve
- F. Modulator valve

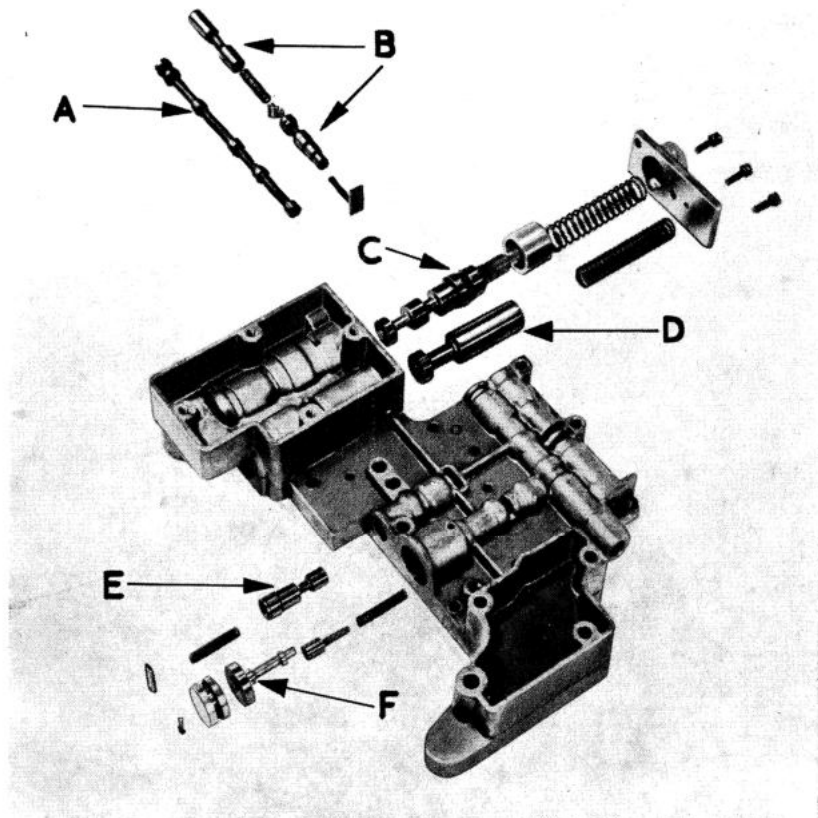

**Fig. 4-83. Upper valve body**

- A. 1-2 shift valve and plunger
- B. 2-3 shift valve and plunger

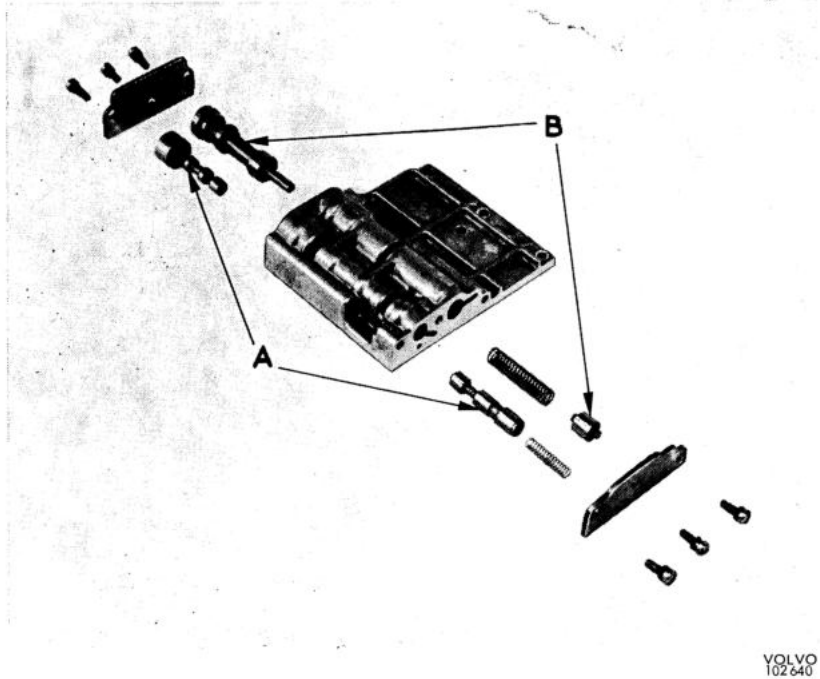

VOLVO  
102640

#### FRONT AND REAR SERVOS

16. Remove the two screws which retain the front servo to the body, withdraw the servo and the strut for the band.
17. Remove the snap ring in the servo with a small screwdriver. Take out the piston and separate the various parts. Drive out the slotted spring pin and lever pivot pin if necessary.
18. Unscrew the two screws which retain the rear servo and withdraw this and the strut.
19. Unhook the spring. Drive out the pivot pin and remove the lever. Pull out the piston.

#### FRONT PUMP ASSEMBLY

20. Remove the oil tubes in the housing. In case of difficulty pull them out with needle-nose pliers as shown in Fig. 4-84.
21. Set up the dial indicator gauge as shown in Fig. 4-85 with plate SVO 2532 and magnetic attachment. Place the point of the gauge against the shaft end, move the shafts and gears backwards and forwards and read of the end float. This should be 0.010—0.030" (0.25—0.75 mm). Note the amount of play.
22. Unscrew the six bolts which retain the front pump to the body. Withdraw the pump and remove the

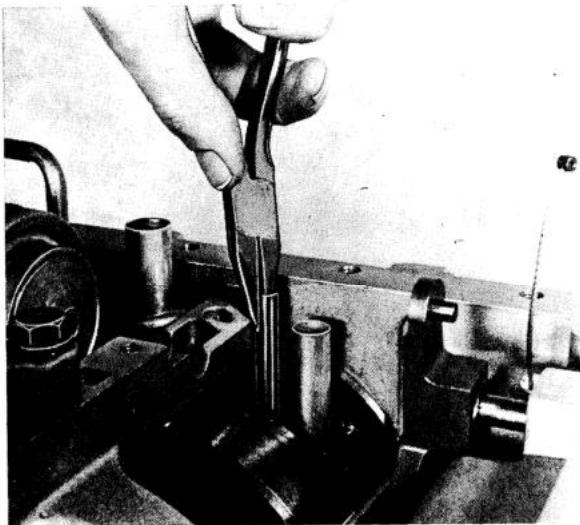

VOLVO  
105383

**Fig. 4-84. Removing converter inlet and outlet tubes using needle-nose pliers**

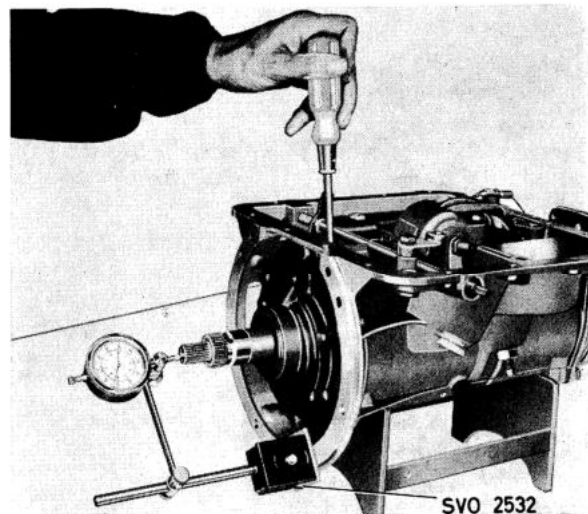

VOLVO  
400061

**Fig. 4-85. Checking end float**

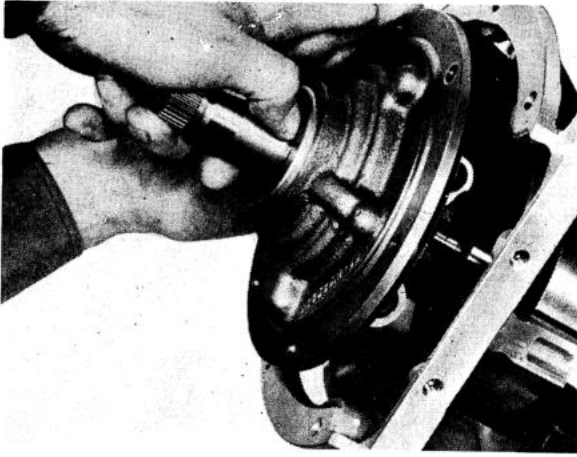

VOLVO  
27665

Fig. 4-86. Removing front pump

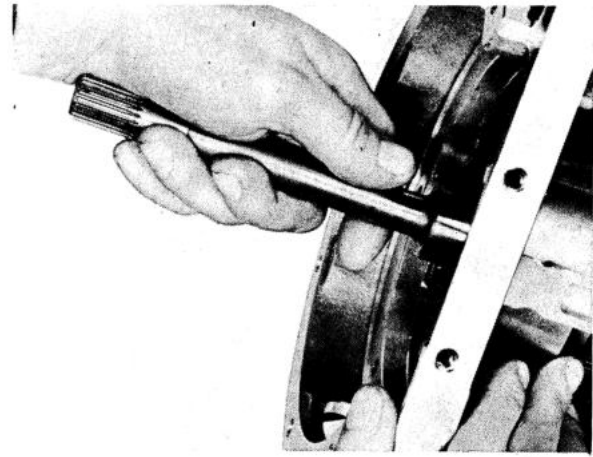

VOLVO  
27970

Fig. 4-88. Withdrawing front clutch assembly

gasket. Push the shaft inwards when withdrawing the pump, see Fig. 4-86.

23. Unscrew the five hexagon bolts and the slotted screw. Separate the pump body, gears and other parts, see Fig. 4-87.

#### FRONT CLUTCH ASSEMBLY

24. Withdraw the front clutch assembly and input shaft complete, see Fig. 4-88. Take care of the thrust washers. Take out the front brake band.
25. Remove the snap ring with a screwdriver. Withdraw the input shaft. Take out the inner and outer plates and the clutch hub.
26. Remove the snap ring, spring, and piston. If the

piston is tight, lay the clutch body with the opening downwards on a bench and blow out the piston with compressed air.

#### REAR CLUTCH ASSEMBLY

27. Withdraw the rear clutch assembly together with the forward sun gear shaft, see Fig. 4-89.
28. Remove the two oil rings at the front of the shaft. Then withdraw the shaft. Take care of the two needle thrust bearings.
29. Remove the three oil rings from the clutch body hub.
30. Remove the snap ring and take out the pressure plate, inner and outer plates.

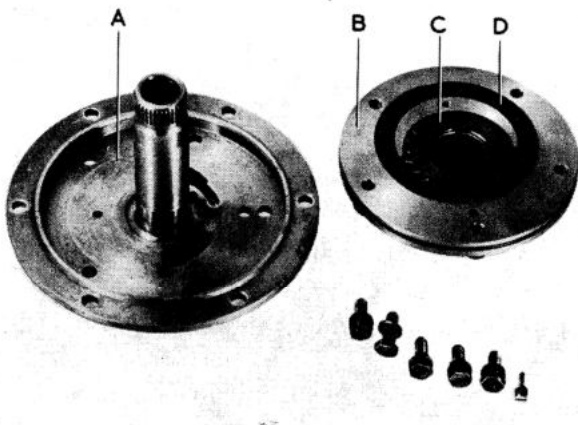

VOLVO  
27669

Fig. 4-87. Converter support separated from front pump

- A. Pump adapter and converter support assembly
- B. Body and bush assembly
- C. Driving gear
- D. Driven gear

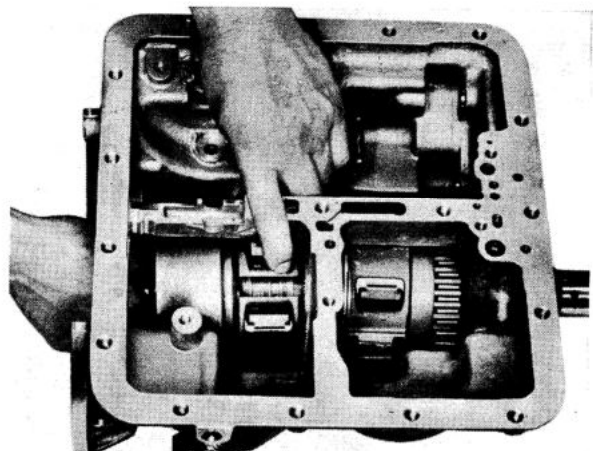

VOLVO  
27668

Fig. 4-89. Withdrawing rear clutch and forward sun gear group

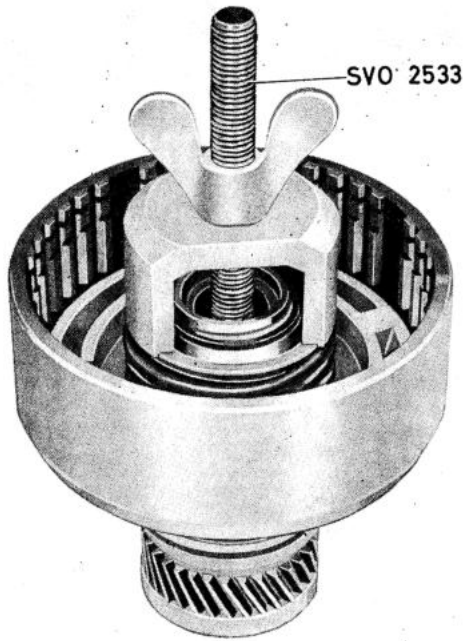

Fig. 4-90. Dismantling rear clutch

VOLVO  
400 059

31. Place special tool SVO 2533 on the clutch as shown in Fig. 4-90. Tighten the wing nut until the snap ring releases. Remove the snap ring and screw back the wing nut. Remove the special tool, then the retainer and spring. Withdraw the piston. If necessary blow out the piston with compressed air.

#### CENTER SUPPORT AND PLANET GEARS

32. From the outside of the transmission case remove the two centre support screws, see Fig. 4-91. With-

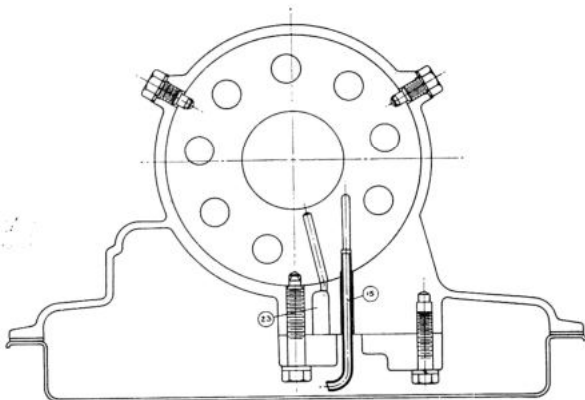

Fig. 4-91. Center support, retention and passages

VOLVO  
279 59

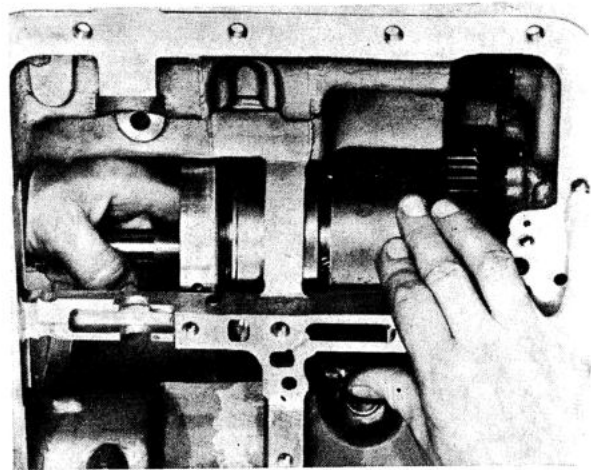

Fig. 4-92. Withdrawing center support and planet gears

VOLVO  
279 63

draw the centre support and planet gears, see Fig. 4-92. Take out the rear brake band. Separate the center support, one-way clutch and planet gears. Remove the snap ring and the outer race of the one-way clutch.

#### GOVERNOR

33. Remove the snap ring, see Fig. 4-93, and withdraw the governor. Take care of the detent ball.
34. Unscrew the two screws and take off the governor sleeve. Take off the spring retainer and separate the various parts. Unscrew the screws and withdraw the cover plate.

#### REAR PUMP

35. Unscrew the five hexagon bolts. Use a thin-walled or ground-diameter socket for the hexagon bolts. Withdraw the pump housing and driven gear.

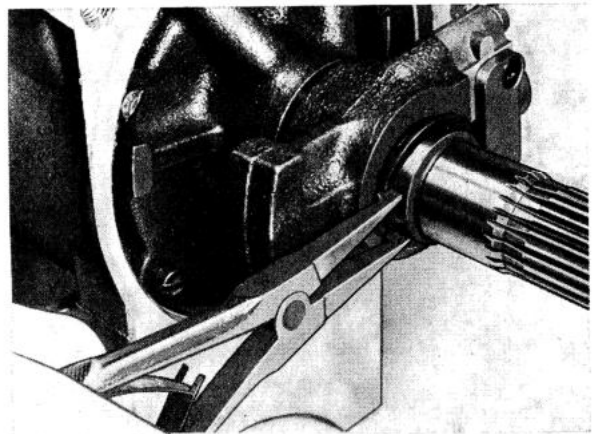

Fig. 4-93. Withdrawing governor

VOLVO  
104 986

Mark the gear on the outside face so that it can be re-fitted correctly.

36. Remove the three oil sealing rings from the driven shaft. Mark the driving gear on the outside face and then withdraw it. Remove the drive key from the shaft and take out the pump plate.

#### DRIVEN SHAFT

37. Withdraw the driven shaft. Remove the thrust washer. If necessary remove the snap ring and separate the ring gear from the driven shaft.

#### SHAFT, PARKING PAWL, AND LEVERS

38. Remove the locking clips with needle-nose pliers. Drive out the slotted spring pins in the manual valve lever shaft. Then drive inwards the slotted spring pin retaining the parking brake toggle pin. Separate the parts. The anchor pin for the parking pawl (the lower of the two pins as viewed with the gearbox inverted) can be withdrawn with a magnet or shaken out by up-ending the gearbox.
39. The throttle cable and other parts in the body are removed as necessary.

#### INSPECTING

After cleaning, all parts should be thoroughly checked for wear or other damage.

Check that the white metal bush for the driven shaft and the pins for the parking pawl linkage are firmly secured in the case. If they are loose, the case must be replaced.

Check the thrust washers and needle bearings for wear and any seizing. If the end-float is within the

permissible limits, it can be taken for granted that the thrust washers are not worn.

Check the gears for wear, seizing or tooth fractures. Also check that the pinions in the planet gear pinion carrier run easily on the needle bearings.

Check the brake bands and discs for wear, overheating or other damage.

#### ASSEMBLING

The utmost cleanliness must be observed when assembling the transmission.

Before assembling, all parts must be carefully washed in white spirit.

Use new gaskets when assembling. Lubricate the parts with "Automatic Transmission Fluid" Type F".

Tighten all bolts with a torque wrench in accordance with the torque chart in the "Specifications". Use sealing compound 277961 on the threads of the inhibitor switch, the pressure point plug and the oil drain. Locking fluid Loctite CV or corresponding is used for the flange bolt, and Loctite AV for the nipples for the oil cooler connections. Note: Items not described in this section are assembled in the reverse order to dismantling.

#### TRANSMISSION CASE, SHAFT, PARKING PAWL AND LEVERS

1. The transmission case is inverted on the bench cradle.
2. Assemble the shaft, parking pawl and levers in the reverse order to dismantling. Make sure that the springs for the levers are correctly fitted, see Fig. 4-95. Fitting the detent ball is facilitated by pressing down the ball using a short length of tubing as shown in Fig. 4-94.

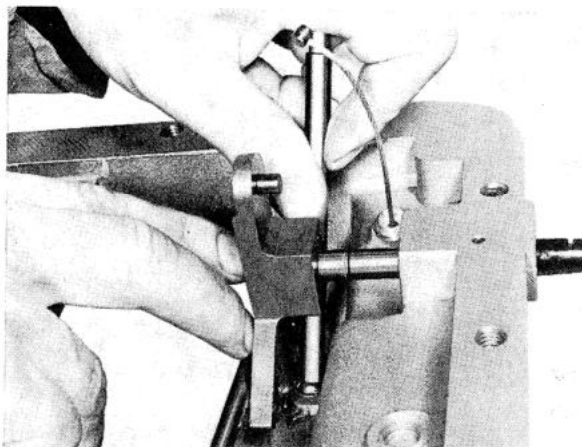

Fig. 4-94. Locating manual valve lever on detent ball spring

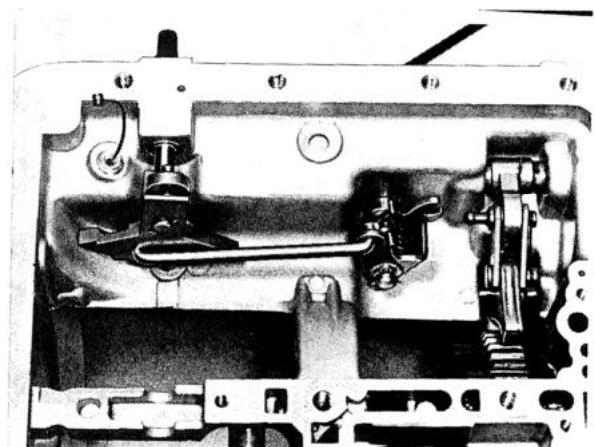

Fig. 4-95. Parking pawl and linkage installed

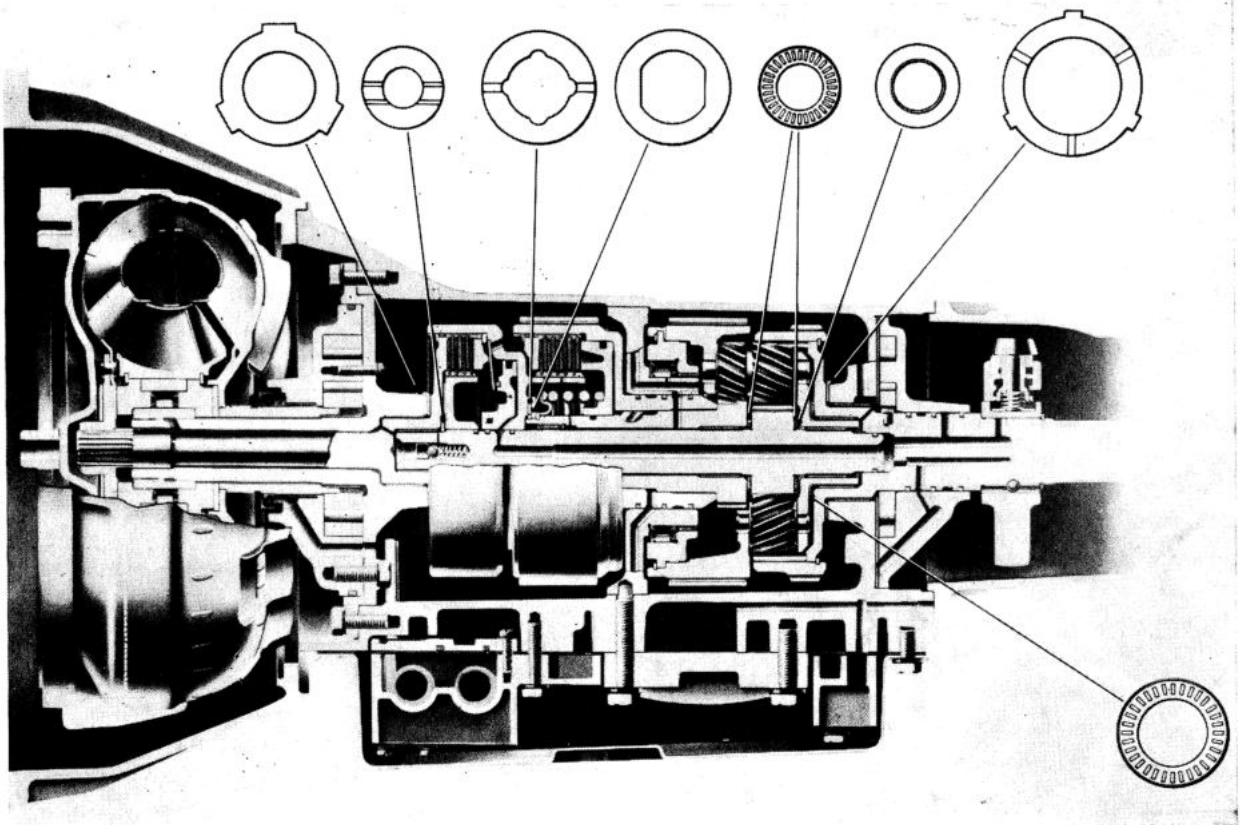

Fig. 4-96. Location of thrust washers

YOLVO  
104987

#### DRIVEN SHAFT

3. The thrust washer for driven shaft, see Fig. 4-96, is stuck onto the transmission case with vaseline. The driven shaft complete with ring gear is then installed into the transmission case.

#### REAR PUMP

4. Fit the pump plate, taking care that its two holes line up with those in the case. Then insert the

5. Fit the three oil sealing rings on the shaft, see Fig. 4-97. Exercise care when doing this as the oil sealing rings are very fragile. Stand the box on its front end and support under the shaft. Centre the oil rings. The pump body with driven gear is then fitted.

#### GOVERNOR

6. Place the governor drive ball in the shaft as shown in Fig. 4-100. Fit the governor with the cover-plate facing the rear. Fit the snap ring.

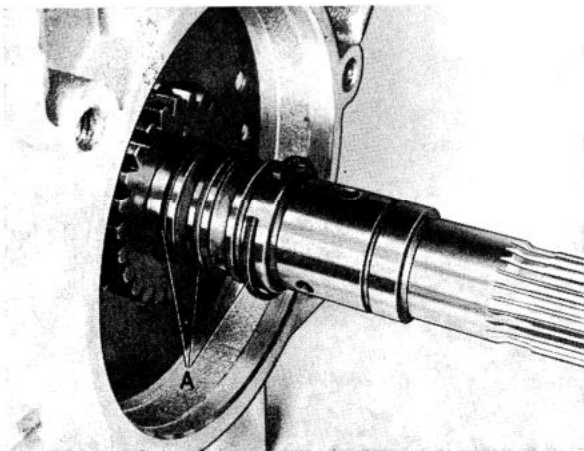

Fig. 4-97. Installing driven shaft oil rings  
A. Oil rings

YOLVO  
104987

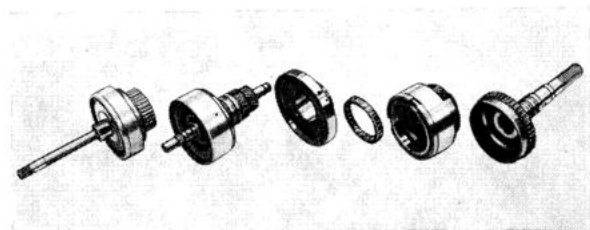

Fig. 4-98. Gear train components

YOLVO  
104988

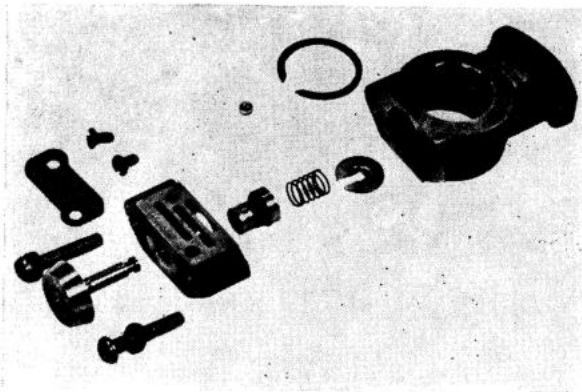

Fig. 4-99. Governor assembly dismantled

VOLVO  
27664

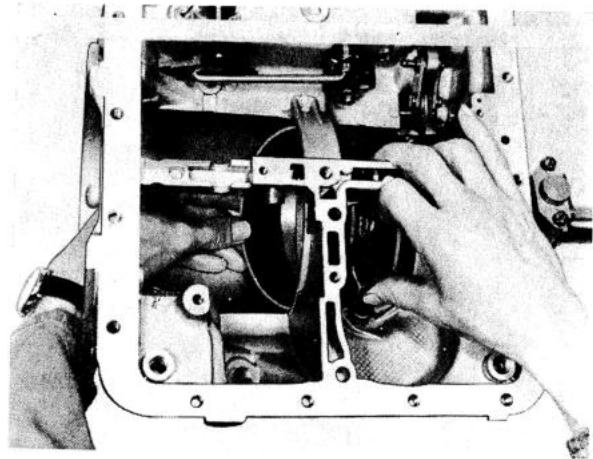

Fig. 4-101. Installing rear brake band

VOLVO  
105386

### REAR BRAKE BAND AND SERVO

- Place the rear brake band in position in the case, see Fig. 4-101. Then fit the rear servo assembly. Tighten only the rear (short) servo screw since the long one also locates the centre support.

sealing washers so that the flat surface should face inwards. Then tighten the servo screw locating the support.

### PLANET GEAR AND CENTER SUPPORT

- Assemble the planet gear, one-way clutch and center support, see Fig. 4-103. Stick the thrust plate and needle thrust bearing to the planet cover with vaseline.
- Turn the fluid passage holes in the center support upwards and fit the assembled unit into the transmission case. (Note that the holes point downwards when the transmission is turned the right way up, see Fig. 4-91.)
- Fit the two center support screws from outside. Remember that the lock washers also serve as

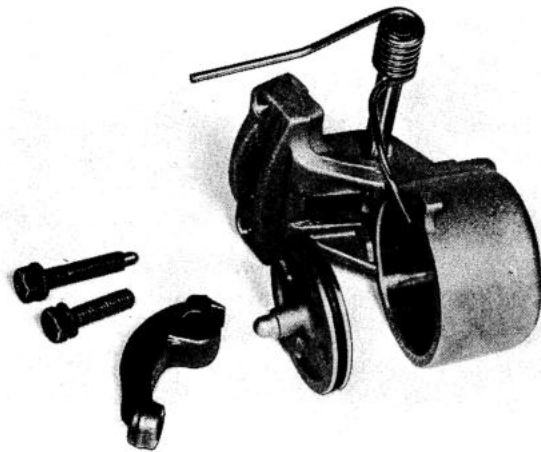

Fig. 4-102. Rear servo assembly dismantled

VOLVO  
103842

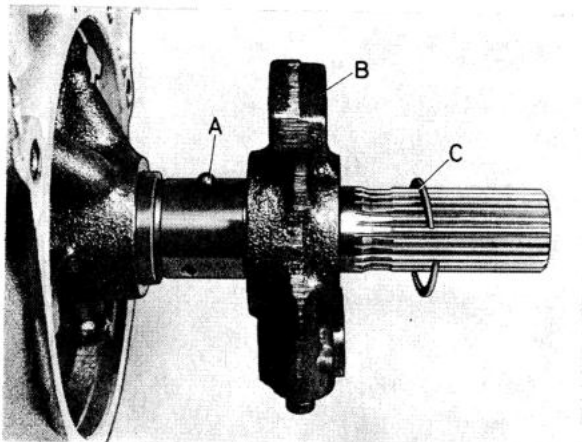

Fig. 4-100. Governor and driven shaft

- Drive ball
- Governor assembly
- Snap ring

VOLVO  
104969

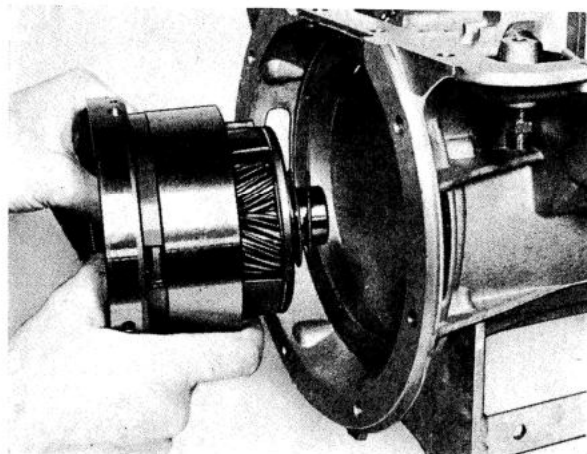

Fig. 4-103. Installing center support and planet gears with needle thrust bearing and plate washer

VOLVO  
105387

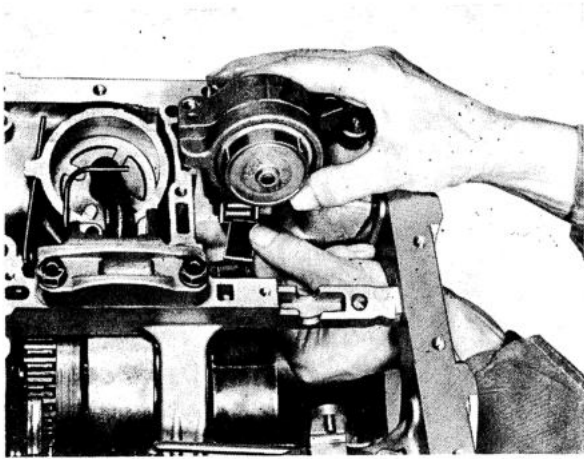

Fig. 4-104. Installing front servo and strut

VOLVO  
105 388

### FRONT BRAKE BAND AND SERVO

- Place the front brake band in position, see Fig. 4-104. Stick the strut to the servo lever with vaseline.

Fit the servo. The shorter bolt is fitted at the front. Make sure that the servo strut is correctly engaged with the slot in the brake band.

The cam for self-adjustment is fitted later.

### REAR CLUTCH

- Fit the sealing rings for the piston. Use fitting ring SVO 2534 and fit the piston in the clutch case, see Fig. 4-107.
- Fit the spring, spring seat and snap ring using special tool SVO 2533, which is used when dismantling, see Fig. 4-90.
- Install the clutch plates. Note that the outer plates are coned and that all the plates should be fitted with the cone facing in the same direction. Begin with an outer plate and then fit inner and outer plates alternately. Fit the pressure plate and snap ring.

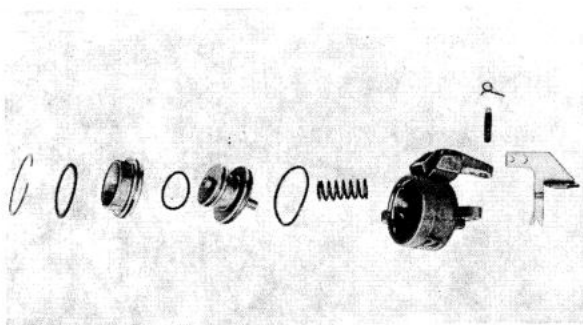

Fig. 4-105. Front servo assembly dismantled

VOLVO  
105 389

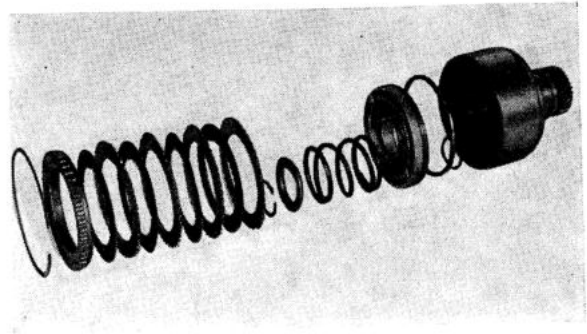

Fig. 4-106. Rear clutch dismantled

VOLVO  
28021

- Place the front needle thrust bearing on the rear sun gear shaft. Fit the shaft in the rear clutch assembly. Install the oil sealing rings, see Fig. 4-108.
- Install the rear needle thrust bearing and fit the clutch in the gearbox as shown in Fig. 4-109.

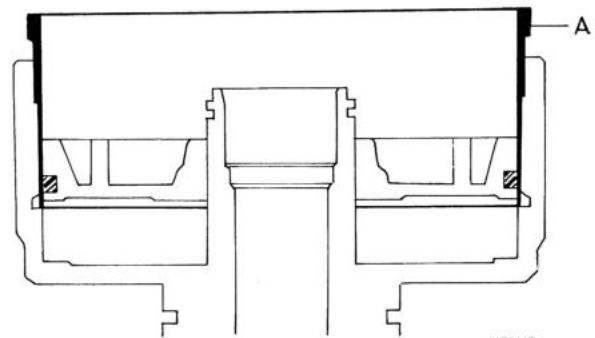

Fig. 4-107. Installing piston for rear clutch

A. Fitting ring SVO 2534

VOLVO  
28003

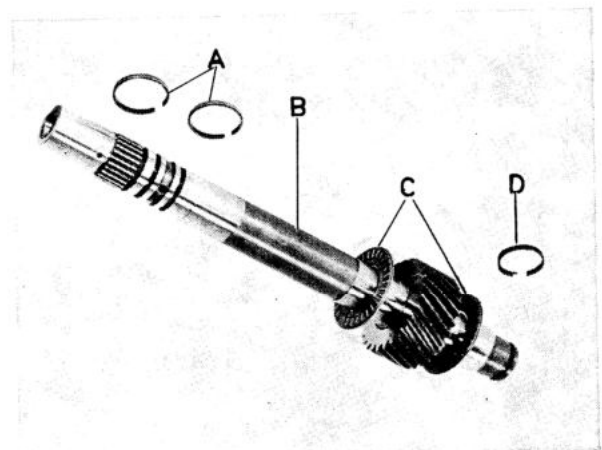
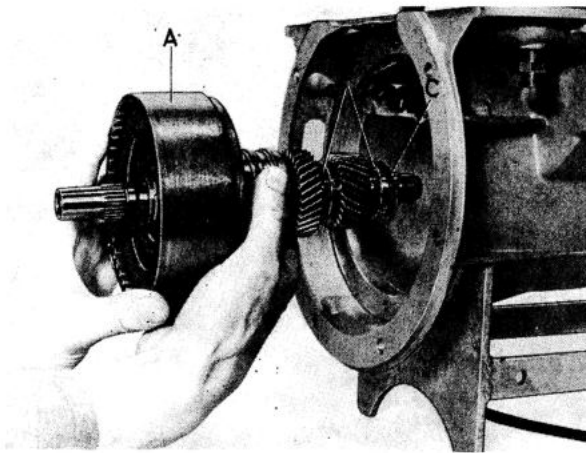

Fig. 4-108. Forward sun gear components

- Oil sealing rings, front clutch
- Forward sun gear assembly
- Needle thrust washers
- Oil sealing ring, governor feed

VOLVO  
27973



VOLVO  
105390

**Fig. 4-109. Installing rear clutch and forwards sun gear group**

- A. Rear clutch
- B. Needle thrust bearings
- C. Thrust washer plate

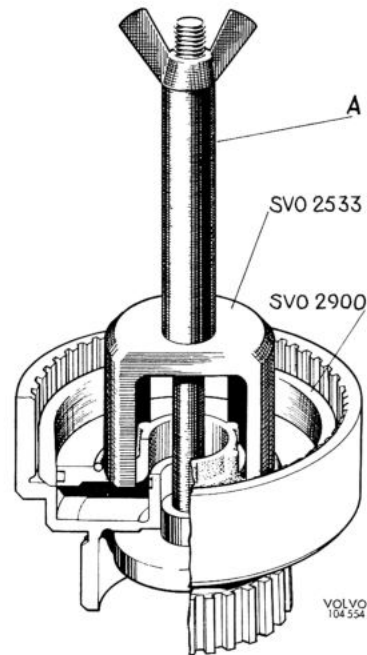

VOLVO  
104554

**Fig. 4-111. Fittings piston for front clutch**

- A. Tube, length 4.3" (110 mm)

### FRONT CLUTCH

17. Fit the sealing ring on the piston and the O-ring in the drum. Place the piston in installation ring SVO 2900. Press it down level with the lower edge of the ring. Use press tool SVO 2533 and tube A as shown in Fig. 4-111. Fit the spring with the dished side facing rear. Put on the snap ring.
18. Install the clutch assembly with its two different thrust washers in the gearbox, see Fig. 4-112. Be careful not to damage the oil sealing rings. For identifying the thrust washers, see Fig. 4-96.
19. Fit the pressure plate, inner and outer plates, and hub. Fit the thrust washer for the clutch hub and input shaft into the front clutch, see Fig. 4-113. Fit the snap ring.

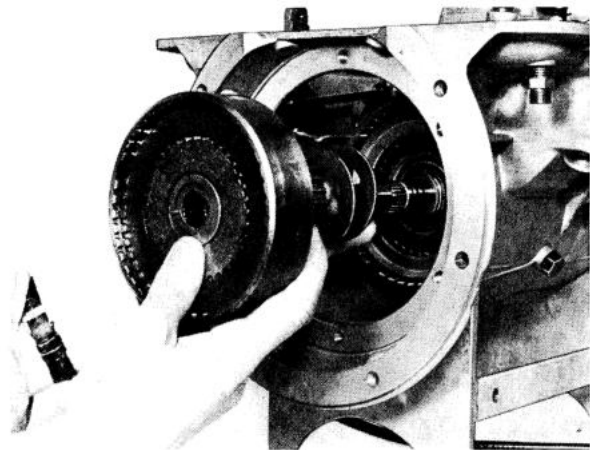

VOLVO  
105391

**Fig. 4-112. Installation sequence, front clutch cylinder thrust and backing washers**

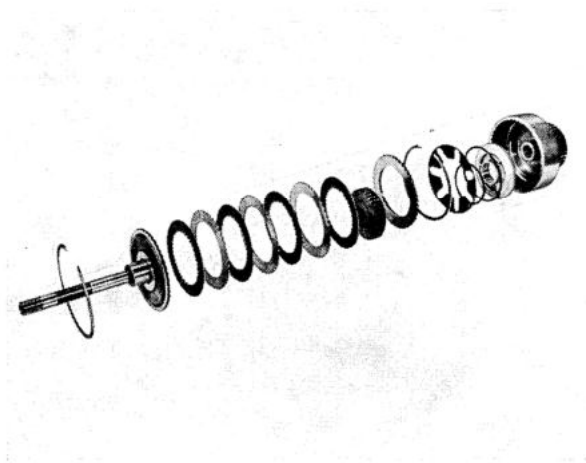

VOLVO  
28004

**Fig. 4-110. Front clutch dismantled**

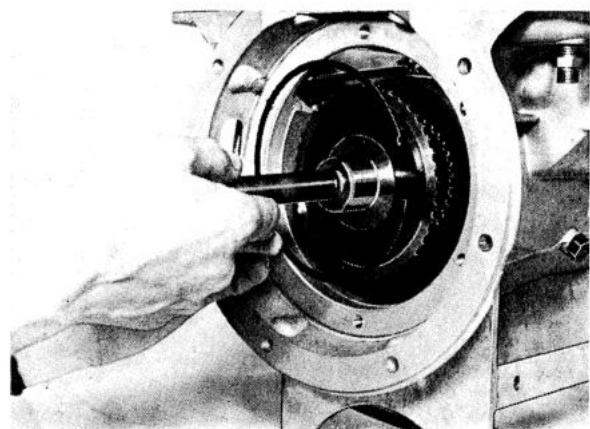

VOLVO  
105392

**Fig. 4-113. Installation sequence, front clutch snap ring, input shaft and thrust washer**

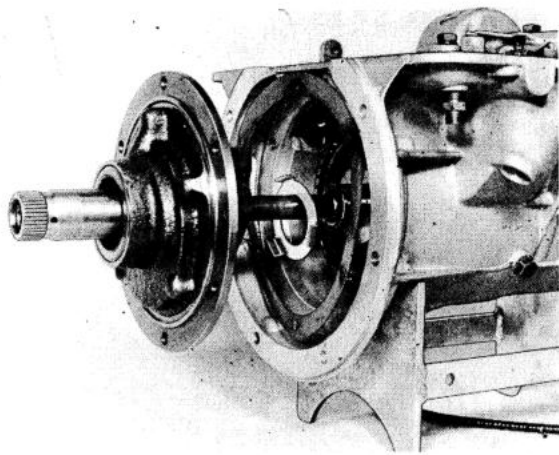

Fig. 4-114. Installation sequence, front pump assembly thrust washer and gasket

The front and rear clutches can also be installed in the gearbox as an assembly. In this case they are first assembled individually. The rear clutch is then stood straight up, the thrust washer for the clutch hub centred, both the rear thrust washers placed on, and after this the rear clutch and sun gear are assembled with the front clutch.

#### FRONT PUMP

20. Fit the O-ring on the pump body, then assemble the pump in the reverse order to dismantling.
21. Stick on the thrust washer with vaseline and then fit the pump with a new gasket on the transmission case, see Fig. 4-114. Re-check the end float in accordance with point 21, page 34.

#### EXTENSION HOUSING

22. Place the speedometer gear correctly on the driven shaft as shown in Fig. 4-115. Fit the extension hous-

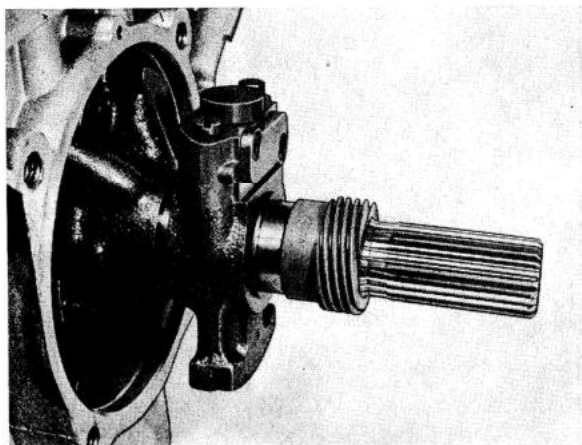

Fig. 4-115. Installing speedometer gear

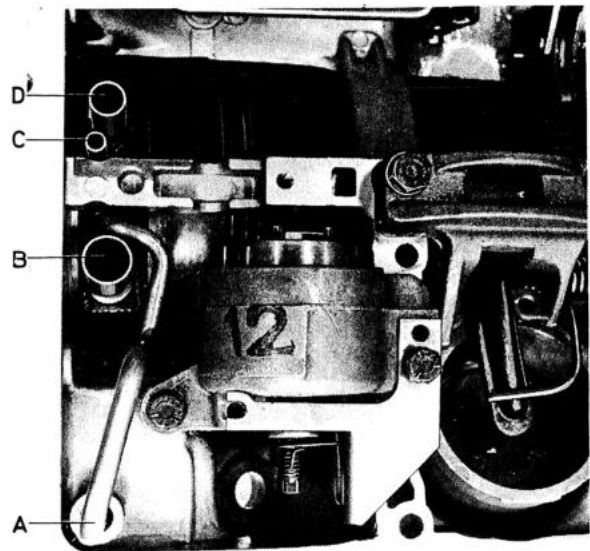

Fig. 4-116. Location of oil tubes, front of gearbox

- |                     |                      |
|---------------------|----------------------|
| A. Converter outlet | C. Converter inlet   |
| B. Front pump inlet | D. Front pump outlet |

ing with a new gasket and fit the drive flange with washer and nut.

#### VALVE BODIES ASSEMBLY

23. When assembling, all the component parts which have been dismantled should be thoroughly cleaned and lubricated with oil approved as "Automatic Transmission Fluid, Type A" prior to reassembling in the reverse order to dismantling. Line up the component parts of the valve bodies assembly by using two of the retaining bolts. Check the free movement of all valves in their bores. Check that the strainers are flat so that they make a complete seal when screwed down. Tighten the screws to the specified torque.

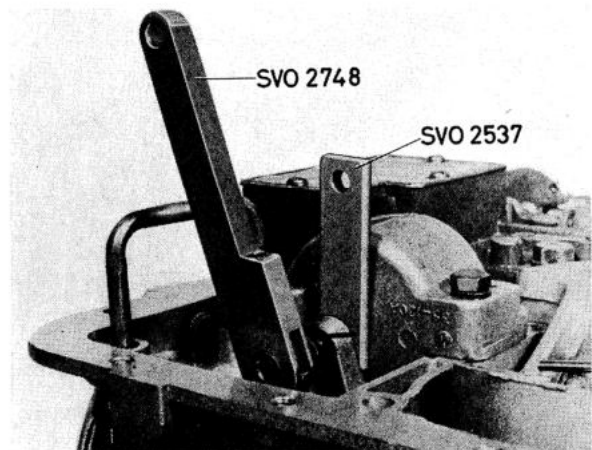

Fig. 4-117. Adjusting front brake band

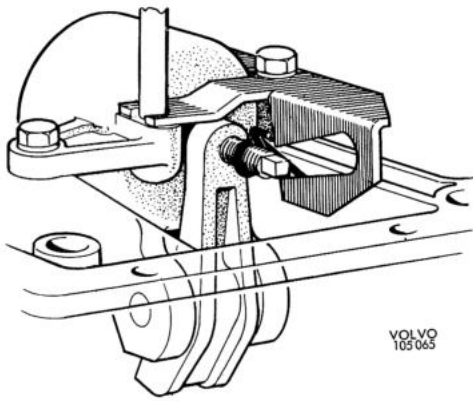

Fig. 4-118. Self-adjusting spring bolt cam

24. Fit the oil tubes for the pump and converter on the front pump, see Fig. 4-116. Do not forget the O-ring for the pump inlet tube.
25. Fit the valve bodies assembly onto the gearbox. Connect the throttle cable.

### MISCELLANEOUS

26. Place the spacer block SVO 2537 between the bolt and cylinder, see Fig. 4-117. Tighten the bolt with torque wrench SVO 2748 until the ratchet handle clicks out. This should be at a torque of 10 lb.in. (11.5 kp/cm).
27. Adjust the location of the spring on the adjusting screw. It should be 1—2 threads from the lever. Remove the torque wrench and spacer block. Fit the cam. The long end of the spring sticks into the cam, see Fig. 4-118.
28. Fit the four oil tubes according to Fig. 4-119. Note that the oil tube for releasing the front control cylinder has a constriction (A, Fig. 4-120) on vehicles with a right-hand drive. This end is fitted in the valve bodies system.
29. Adjust the brake bands, see "Adjusting the rear brake band" on page 30. Adjust the starter in-

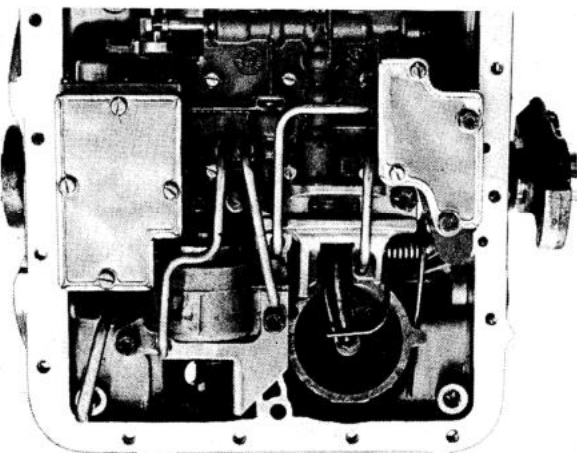

Fig. 4-119. Retention of front and rear pump strainers

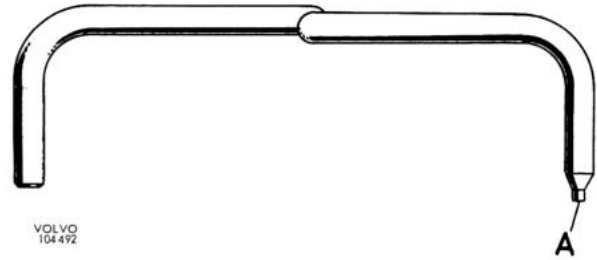

Fig. 4-120. Oil tube for valve bodies system, vehicle with R-H drive

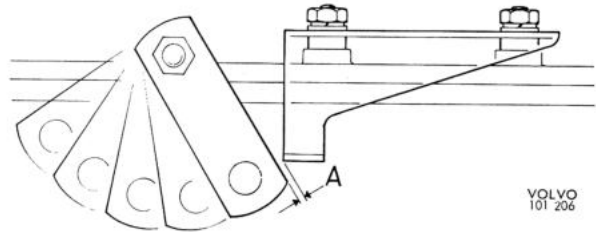

Fig. 4-121. Stop for lever  
A=1/8—5/32" (3—4 mm)

hibitor switch, see "Adjusting the starter inhibitor switch" on page 29.

30. Place the magnetic piece in the oil pan. Fit the oil pan with a new gasket.
31. On cars which have six control positions, the stop bracket is fitted as shown in Fig. 4-121. Adjustment is carried out as follows:
  - A. Turn the lever **clockwise** as far as it will go ("P" position) and then four "catches" **anti-clockwise**.
  - B. Push the stop bracket forwards so that it comes 1/8—5/32" (3—4 mm) from the lever see "A" Fig. 4-118. Tighten the bracket in this position.

### FITTING

The converter, converter housing and gearbox are fitted in the reverse order to removing. Connect the leads for the starter inhibitor switch and reversing light correctly, see Fig. 4-122.

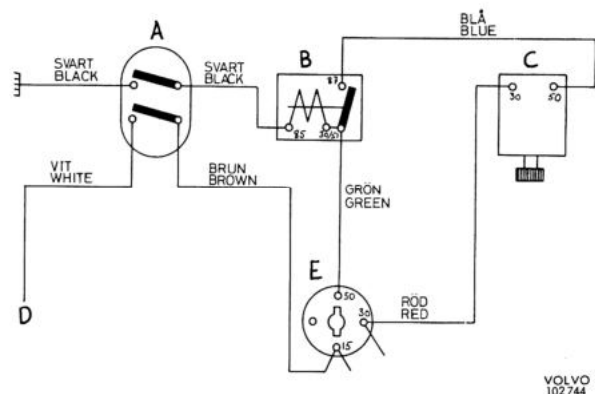

Fig. 4-122. Wiring diagram

- |  |                              |
|--|------------------------------|
| A. Switch on gearbox for starter inhibitor and reversing light | C. Starter motor             |
| B. Starter relay   | D. Cable for reversing light |
|  | E. Ignition switch           |



# FAULT TRACING

## ROAD-TESTING

(Used together with the fault-tracing scheme).

It is important to gain as much information as possible as to the precise nature of any fault. If possible, go out in the car with the customer and get him to demonstrate the fault. In all cases, the following road-test procedure should be carried out completely as there may be more than one fault.

### TEST NO.

1. Check that the starter only operates with the selector in "P" and "N" and that the reversing light operates only in "R".
2. Apply the brakes and, with the engine running at normal idling speed, select "N—D", "N—L" and "N—R". Transmission engagement should be felt in each position selected.
3. Check the converter stall speed with the transmission in "L" and "R". Check for slip or clutch squawk.  
Note. Do not stall for longer than 10 seconds or the transmission will overheat.
4. With the transmission at normal running temperature, select "D". Release the brakes and accelerate with minimum throttle opening. Check for 1—2 and 2—3 shifts. Note. At minimum throttle openings, the shifts may be difficult to detect. Confirmation that the transmission is in 3rd gear may be obtained by selecting "L", when a 3—2 downshift should be felt.
5. At just over 30 m.p.h. (50 km.p.h.), select "N", switch off the ignition and let the car coast. At 30 m.p.h. (50 km.p.h.) switch on the ignition and select "D". The engine should then start through

the rear wheels, indicating that the rear oil pump of the transmission is operating.

- 6a. Stop and restart using full throttle acceleration. Check for 1—2 and 2—3 shifts according to the shift speed table in the "Specifications".
  - b. At 25 m.p.h. (40 km.p.h.) in 3rd gear, depress the accelerator to full throttle position. The car should downshift to 2nd gear. Repeat at 40 m.p.h. (65 km.p.h.). The car should accelerator in 3rd gear and should not downshift to 2nd.
  - c. At 30 m.p.h. (50 km.p.h.) in 3rd gear, depress the accelerator to the kick-down position. The transmission should downshift to 2nd gear.
  - d. At 15 m.p.h. (25 km.p.h.) in 3rd gear, depress the accelerator to the kick-down position. The transmission should downshift to 1st gear.
- 7a. Stop and restart using forced throttle acceleration. Check for 1—2 and 2—3 shifts according to the shift speed table in the "Specifications".
  - b. At 40 m.p.h. (65 km.p.h.) in 3rd gear, release the accelerator and select "L". Check for 3—2 downshift and engine braking. Check for roll-out 2—1 downshift at about 5 m.p.h. (8 km.p.h.) and engine braking.
8. Stop, and with "L" still engaged, release brakes and, using full throttle, accelerate to 20 m.p.h. (30 km.p.h.) Check for no slip or clutch squawk and no upshifts.
9. Stop and select "R". Release brakes and reverse using full throttle if possible. Check for no slip or clutch squawk.
10. Stop on the brakes facing downshift on a gradient and select "P". Release the brakes and check that the parking pawl will hold the car. Re-apply the brakes before disengaging the parking pawl. Repeat with the car facing uphill. Check that the selector is trapped by the gate in "P".

## FAULT-TRACING SCHEME

(To be used in conjunction with the road-test procedure.)

TEST	FAULT	ACTION
1.	Starter will not operate in "P" or "N"	19
	Starter operates in all selector positions	20
2.	Excessive bump on engagement of "D", "L" or "R"	4, 3
3.	If stall speed higher than specified:	
	a. with slip and squawk in "L"	1, 2, 3, 13, 11
	b. with slip and squawk in "R"	1, 2, 3, 13, 12
	If stall speed lower than specified, check engine performance	
	If stall speed more than 600 r.p.m. lower than specified	21
4.	No drive in "D" (if normal in "L", omit 11 and 13; if no drive in "D", "L" or "R", add 17)	1, 2, 3, 13, 11, 16
	Delayed or no 1—2 shift	3, 14, 13, 5, 6
	Slip on 1—2 shift	2, 3, 5, 6, 7, 13
	Delayed or no 2—3 shift. (If normal in "R", omit 12).	3, 14, 13, 5, 6, 12
	Slip or engine run-up on 2—3 shift	2, 3, 5, 13, 12
	Bumpy gear shifts	3
	Drag in "D 2" and "D 3"	8
	Drag on 2—3 shift	5, 6
5.	Engine will not start through rear wheels	22
6 a.	Slip and squawk or judder on full throttle take-off in "D"	1, 2, 3, 13, 11
	Loss of performance and overheating in "D 3" (seized stator)	21
	Continue as for test 4 above	
	b. Transmission downshifts too easily	3
	c, d. Transmission will not downshift	3, 13, 14
7 a.	As test 6a above	1, 5, 6, 7, 12
	b. No 3—2 downshift or engine braking	1, 5, 6, 7, 12
	No 2—1 downshift or engine braking	8, 9, 10
8.	Slip and squawk or judder on take-off in "L"	1, 2, 3, 13, 11
	Transmission upshifts	1
9.	Slip and squawk or judder on take-off in "R"	1, 2, 3, 13, 12
	Slip but no judder on take-off in "R" (if engine braking available in "L 1", omit 8, 9, 10)	1, 2, 3, 8, 9, 10
	Drag in "R"	5
	No drive in "R" (if engine braking available in "L 1", omit 8, 9, 10)	1, 2, 3, 8, 13, 9, 10, 12
10.	No park	1, 15
Mis-	Screech or whine, increasing with engine speed	17
cell-	Grinding or grating noise from gearbox	18
aneous	Knocking noise from torque converter area	23
	At high speeds in "D 3", transmission downshifts to "D 2" and immediately back to "D 3"	12

## ACTION

1. Check manual linkage adjustment.
2. Check fluid level.
3. Check adjustment of downshift valve cable using line pressure gauge and tachometer.
4. Reduce engine idling speed.
5. Check front band adjustment.
6. Check front servo seals and tubes for leakage.
7. Check front band for wear.
8. Check rear band adjustment.
9. Check rear servo seal and fit of tubes.
10. Check rear band for wear.
11. Examine front clutch and seals, also front sun gear shaft sealing rings. Verify that cup plug in driven shaft is not leaking or dislodged.
12. Examine rear clutch, check valve, and seals. Check fit of tubes.
13. Strip valve bodies and clean.
14. Strip governor valve and clean.
15. Examine parking pawl, gear and internal linkage.
16. Examine one-way clutch.
17. Strip and examine front pump and drive fingers.
18. Strip and examine gear train.
19. Adjust starter inhibitor switch inwards.
20. Adjust starter inhibitor switch outwards.
21. Replace torque converter.
22. Check rear pump drive pin.
23. Examine torque converter drive plate for cracks or fracture.

## FAULT-TRACING ON THE CONVERTER

The converter housing is welded together and can therefore not be repaired but must be replaced in the event of defects. There is no drain plug since fluid changes do not occur and fluid filling is done through the transmission.

The stall speed means the speed obtained at full throttle on the engine with the lock-up engaged but with the car stationary. Check that the transmission has the correct running temperature and that the fluid level is correct before the stall speed test. The test must not take place longer than ten seconds, otherwise the transmission will overheat.

Fault-tracing on the converter is carried out as follows:

1. If the general performance of the vehicle is below standard, check the converter stall speed with an accurate tachometer by applying maximum pressure on the footbrake pedal, selecting "Lock-up" and fully depressing the accelerator. If the stall speed is up to 300 r.p.m. below that specified, the engine is not developing its full power.
2. Inability to start on steep gradients combined with poor acceleration from rest indicates that the converter stator one-way clutch is slipping or that the stator support is fractured. This condition permits the stator to rotate in an opposite direction to the turbine and torque multiplication cannot occur. Check the stall speed and, if it is more than 600 r.p.m. below that specified, the converter assembly must be replaced.
3. Below standard acceleration in 3rd gear above 30 m.p.h. (50 km.p.h.) combined with a substantially reduced maximum speed, indicates that the stator one-way clutch has locked in the engaged condition. The stator will then not rotate with the turbine and impeller, therefore the fluid flywheel phase of the converter performance cannot occur. This condition will also be indicated by excessive overheating of the transmission, although the stall speed will remain as specified. In this case the converter assembly must be replaced.
4. Stall speed which is higher than that specified, indicates that the converter is not receiving its required fluid supply or that slip is occurring in the clutches of the automatic transmission.