



SERVICE MANUAL

VOLVO 164 1971

GROUP 38

INSTRUMENTS
TOOLS

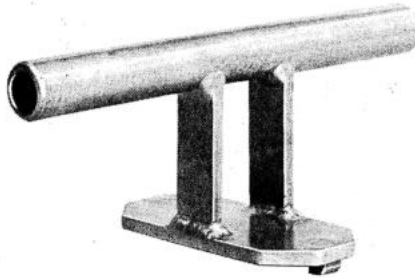

SVO 2935

VOLVO
115 226

Fig. 3-88. Special tools for removing and fitting tank armature

DESCRIPTION

INSTRUMENTATION

Instrumentation consists of a combined instrument, see Figs. 3-89 and 3-90, comprising speedometer, mileometer and trip meter, voltage stabilizer fed tempera-

ture gauge and fuel gauge, warning lamps and rheostat controlled instrument lighting. The temperature gauge, fuel gauge, warning and instrument lighting lamps, voltage stabilizer and rheostat for the instrument lighting are mounted on a common base plate, see Figs. 3-91 and 3-92.

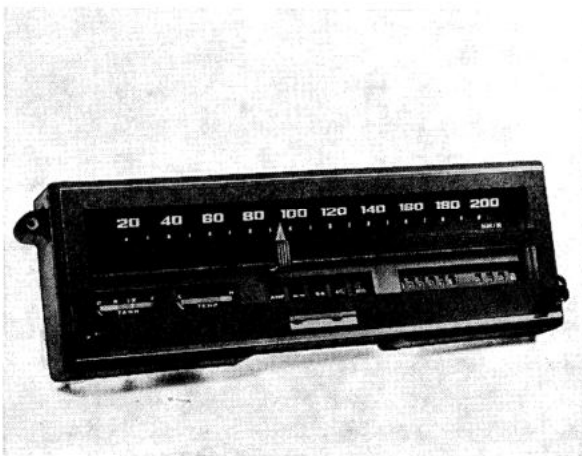

VOLVO
103282

Fig. 3-89. Combined instrument, front side

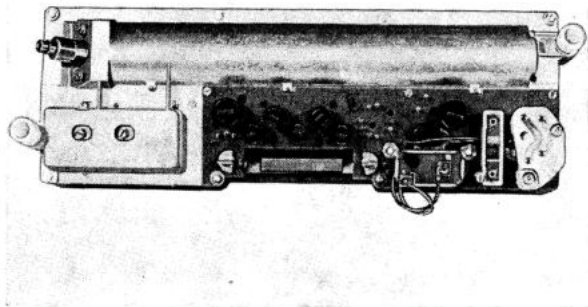

VOLVO
104 406

Fig. 3-90. Combined instrument, reverse side

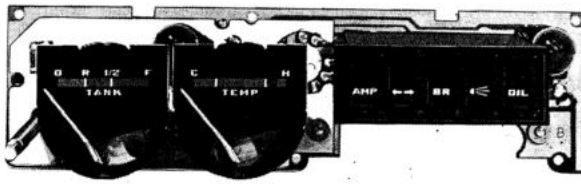

Fig. 3-91. Mounting plate with instruments and warning lamps

VOLVO
104407

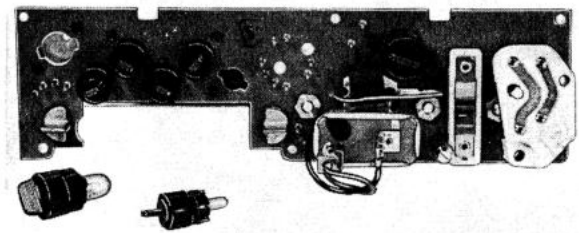

Fig. 3-92. Instrument base plate, reverse side, with warning lamp and instrument lighting lamp

VOLVO
104408

SPEEDOMETER

The speedometer is of the eddy current type. In the speedometer there is a permanent magnet which is mechanically connected with a speedometer cable driven from a worm gear on the gearbox. Surrounding the magnet is a drum, coil spring and roller mounted on a separate shaft. Rotation of the magnet generates eddy currents which produce a turning torque on the drum. The coil spring limits the degree of torque when the speed of the magnet increases. The effect of magnet and coil spring is balanced so that the rotational speed of the roller gives a reading proportional to the speed of the car.

The mileometer and trip meter are driven by a gear drive in the combined instrument.

TEMPERATURE GAUGE

Temperature is measured electrically by means of an instrument of bimetal type. This unit consists of a sender, fitted to the engine, and a registering instrument, mounted in the combined instrument, which is fed through a voltage stabilizer. The sender is of the semi-conductor type, i.e. it contains a semi-conductor, the electrical resistance of which alters with the ambient temperature. The amount of current passing through the sender is proportional to the temperature registered by the instrument.

The amount of current passing through the sender and instrument determines the degree of heat in the bimetal of the instrument and, correspondingly, the reading. As the engine warms up, a higher current is passed through the sender and results in a higher instrument indication.

FUEL GAUGE

The amount of fuel in the tank is measured electric-

ally. Measurement is achieved by means of an indicating instrument of bimetal type and a pickup mounted in the fuel tank. Current is fed through the same voltage stabilizer as for the temperature gauge. The pickup consists of a variable resistor, a lever and a float. Depending upon the amount of fuel in the tank and, correspondingly, the position of the float, a large or lesser part of the pickup resistor is in circuit. The bimetal instrument used here is of the same type as that in the temperature gauge.

VOLTAGE STABILIZER

The temperature and fuel gauges are powered by a voltage of approx. 5.1 volts and are fed through a voltage stabilizer. This stabilizer contains a bimetal spring and a contact breaker. When the ignition is switched on, current flows through the stabilizer and out to the instruments. This heats the bimetal spring of the stabilizer which bends and thus breaks the circuit. As the spring cools down it returns to its original position and the circuit is closed again. This cycle is repeated continuously, thereby producing a regulated effect corresponding to a constant voltage of approx. 5.1 volts. The breaking and making of the circuit is not visible on the instruments due to their inertia. The stabilizer is mounted on the reverse side of the combined instrument.

WARNING LAMPS

CHARGING

The charging warning lamp is connected to D + (61) on the alternator. The warning lamp lights up when the alternator voltage is lower than the battery voltage. As the alternator voltage rises and commences to charge the battery, the warning lamp is extinguished thus indicating that the alternator is charging.

DIRECTIONAL INDICATORS

The control lamp for the directional indicators flashes when the indicators are engaged. It also flashes when the warning signal flashes are switched on, since the control lamp for these flashers is located in the knob of the traffic indicator switch.

The control lamp for the directional indicators is connected between the flasher sender connection P(c) and the body.

BRAKES

The brake warning lamp receives current from the ignition lock and can be earthed by two procedures. When the parking brake is applied the warning lamp is earthed by a switch, Fig. 3-93, and thus lights, and continues to do so, as long as the parking brake is applied. Should a fault occur in one of the circuits of the hydraulic brake system so that the difference in pressure between the circuits, on application of the brakes, rises to more than 8—10 kg/cm² (114—142 p.s.i.), a warning valve, Fig. 3-94, closes and the warning lamp is lit. The warning lamp signals until the fault in the brake system has been remedied and the warning valve is reset. Concerning resetting the warning valve, see Part 5, Brakes, Group 52.

FULL-BEAM HEADLIGHTS

A warning lamp for full leadlights is lit simultaneous to the full-beam headlights. The warning lamp is connected in parallel with the full-beam headlights at the step relay.

OIL PRESSURE

The warning lamp for oil pressure receives current via the ignition lock and is earthed through a pressure sensitive valve on the engine. With the engine running and at normal pressure, the connection between this lamp and earth, through the engine, is

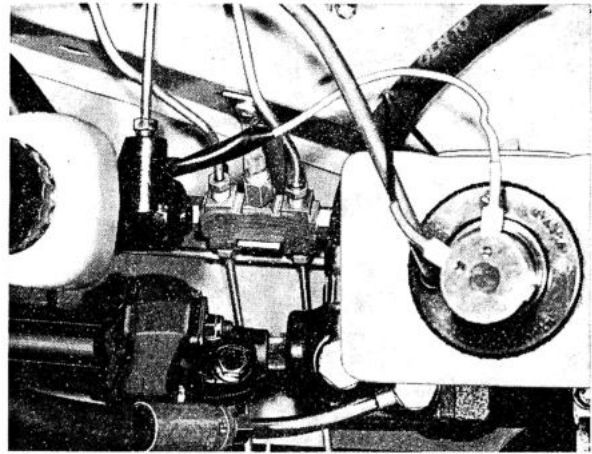

Fig. 3-94. Warning valve

open. When the oil pressure sinks below a pre-determined value the pressure sensitive valve closes the circuit and the warning lamp lights.

OVERDRIVE

The control lamp for the overdrive is located on the combined instrument and lights during the time the overdrive is engaged. It is connected between the switch for the overdrive and body.

ELECTRICALLY HEATED REAR WINDOW

The control lamp for the electrically heated rear window is mounted in the switch knob. It lights when the heating is engaged for the rear window.

CLOCK

Vehicles for markets except U.S.A. are fitted with a electric clock which is located in a panel on the propeller shaft tunnel.

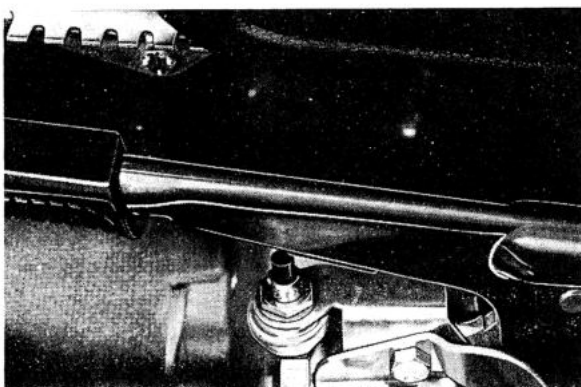

Fig. 3-93. Switch for handbrake warning lamp

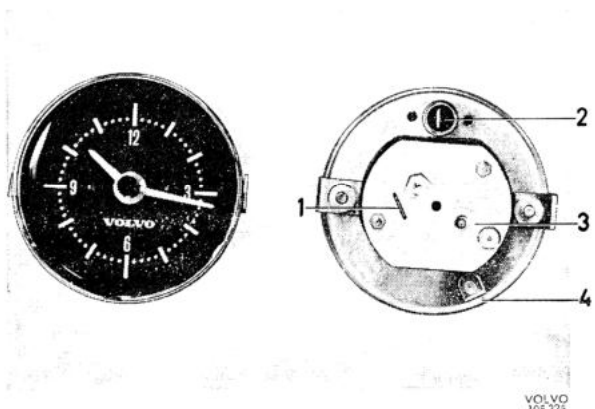

Fig. 3-95. Electric clock, front and reverse

1. Battery terminal
2. Instrument light bulb
3. Inching screws
4. Ground terminal

REPAIR INSTRUCTIONS

During work under the dashboard and instrument panel, the negative cable should be disconnected from the battery to avoid short circuits.

REMOVING THE COMBINED INSTRUMENT

Remove the panel below the dashboard by loosening the two fixing screws, one on the left-hand side of the body and one beside the glove compartment. Then pull the upper section of the panel rearwards so that it loosens from the clips in the dashboard and loosen the panel from the bonnet release mechanism. Remove the controls for the heater unit and the speedometer cable, and also flange nuts for the instrumentation. Turn the instrument 1/4 turn so that the reverse side of the instrument faces upwards. Detach the electrical connections from the instrument. The instrument can then be lifted out through the opening in the panel.

REPLACING WARNING LAMPS AND INSTRUMENT LIGHTING LAMPS

The lamps on the instrument panel, see Fig. 3-92, are mounted in holders which are turned anti-clockwise for removal. The bulbs are released from their holders by pulling them straight out.

The warning lamp for the overdrive is accessible by pulling the holder straight out.

The switch knob must be screwed off in order to reach the warning lamp for heating the rear window.

To replace the warning lamp for the emergency signal flashers, first remove the glass and then the circlip in the switch knob.

REMOVING THE INSTRUMENT BASE PLATE

Pull loose the control knob for the rheostat. (This knob is damaged by removal and must always be exchanged for a new one. It may be necessary to break the knob with, e.g., pliers. (The new knob is fitted by pressing it onto the shaft from the rheostat.) Loosen the screws for the rheostat and pull it out from the spade terminals. Loosen the five remaining screws and lift up the instrument base plate.

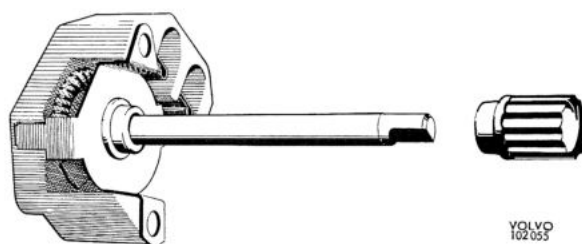

Fig. 3-96. Rheostat for instrument lighting

REMOVING THE FIXING PLATE FOR SPEEDOMETER AND MILEOMETER/TRIP METER

Loosen the snap rings for the attaching nuts and remove the nuts. Loosen the five screws which hold the fixing plate. The fixing plate can be lifted out after all screws for the instrument plate have been removed and the plate is only held in place by the rheostat shaft.

Any repairs or adjustment to the speedometer should always be carried out by an authorized instrument workshop.

CHECKING THE SPEEDOMETER CABLE

It is most important that the speedometer cable is correctly fitted if the speedometer is to function without trouble. It is vitally important that the cable is not bent too sharply. At no point must the radius of a bend be less than 100 mm (4"). If the bending radius

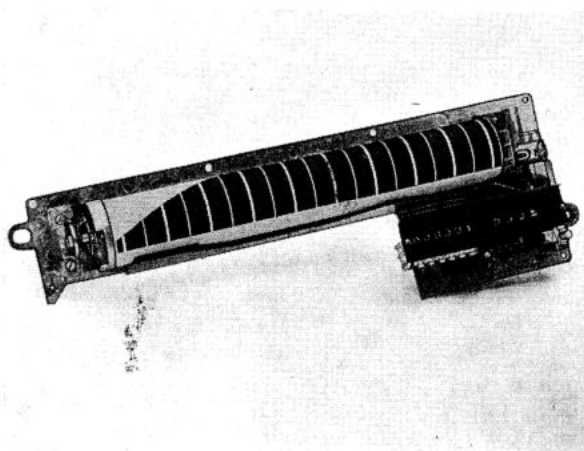

Fig. 3-97. Speedometer with mileometer and trip meter

is less than this, vibration and noise can occur in the instrument. The drive couplings must run true in the outer casing of the cable. This is checked with the cable rotating.

REMOVING AND CHECKING THE TEMPERATURE GAUGE

The sender and indicating instrument are not repairable and the entire unit must be replaced if damaged. The indicating instrument can be separated from the detached instrument panel when the voltage stabilizer has been removed and the nuts holding the instrument are accessible.

The indicating instrument should be checked with an ohmmeter. The resistance should be approx. 12.5 ohms. Measurement is suitably carried out between the nuts on the reverse side of the instrument plate. On no account should the indicator instrument be checked by connecting the sender cable to the car chassis as this will damage the instrument mechanism (too high a voltage on the instrument resistor and overheating of the bimetal spring). If no ohmmeter is available, the above test can be carried out by placing a 10 ohms resistance between the sender cable and the ground connection on the chassis.

The sender should also be checked with an ohmmeter. Resistance in the sender should, at room temperature, be approximately 200 ohms.

The indicating instrument can also be checked by connection to a 12 volt battery, via a voltage stabilizer, and with a previously checked pickup coupled in series. On heating the sender both the instruments

should show a corresponding temperature. A check can suitably be made with a thermometer (sender and thermometer submersed in heated water). Checking values are as follows:

Beginning of green area (at "C")	40° C (105° F)
At dividing line between green areas	70° C (150° F)
At dividing line between green and red areas	100° C (212° F)

If checking is carried out with an instrument which is mounted on the instrument plate, then a 12 volt supply should be connected to terminal 2 on the instrument plate (see wiring diagram), the sender to terminal 8 and the ground cable to terminal 16. Do not forget to ground the sender.

REMOVING AND CHECKING THE FUEL GAUGE

The pickup and fuel gauge are not repairable and must be exchanged if faulty or damaged.

The gauge can be removed from the detached instrument panel when the voltage stabilizer and rheostat have been loosened and the nuts to the instrument are accessible. The fuel gauge should be checked with an ohmmeter. The resistance should be approx. 12.5 ohms. Measurement can suitably be carried out between the nuts on the rear side of the instrument plate.

Checking of the gauge by connecting the pickup lead to earth is not permitted as this will damage the gauge (excessive loading on the resistor wire and overheating of the bimetal spring). If no ohmmeter is available the test can be carried out by connecting a 10 ohms resistor between the lead and grounding point on the chassis.

The pickup, Fig. 3-99, can be removed after the carpet and wooden fibre board in the luggage compartment

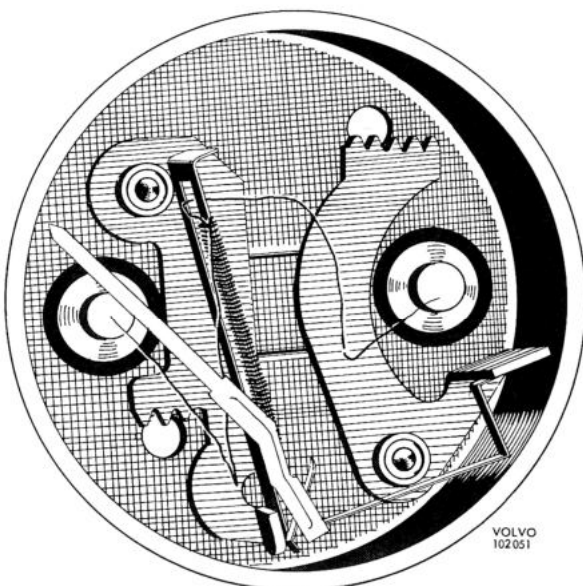

Fig. 3-98. Bimetal type registering instrument

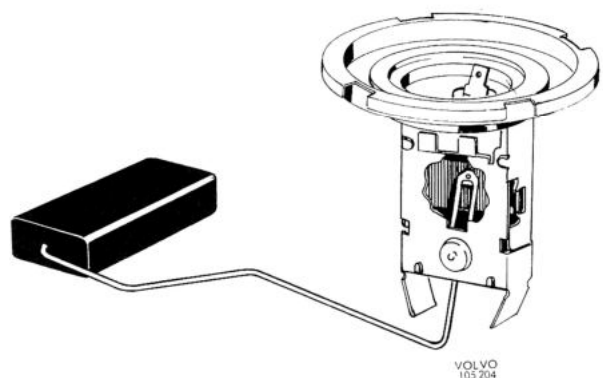

Fig. 3-99. Pickup for fuel gauge

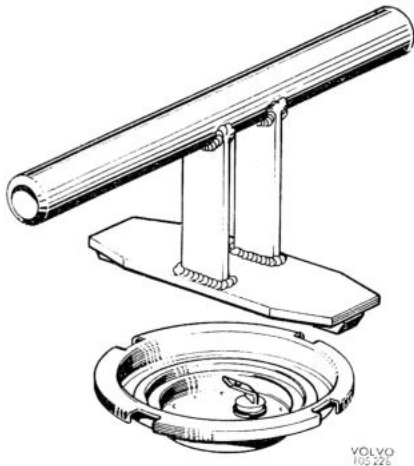

Fig. 3-100. Tool for removing pickup

have been lifted out. The pickup is attached by means of a bayonet fitting. When removing, use tool SVO 2935 as shown in Fig 3-100. The pickup should be checked with an ohmmeter.

At the upper stop the pickup should have a resistance of approx. 10 ohms and at the lower, approx. 60—85 ohms. Movement of the float arm should not result in a break in the circuit (reading).

CHECKING THE VOLTAGE STABILIZER

The voltage stabilizer, see Fig. 3-101, is spring-

suspended in a rubber block and connected to the combined instrument by means of three cables. A functional test on the voltage stabilizer can be carried out with a temperature gauge or a fuel gauge. The instrument (temperature or fuel gauge), is connected in series with a resistance of approximately 12 ohms (instead of pickup) and a constant direct current voltage of 5.1 volts. The reading is then noted. After this the constant direct current is replaced by a 12 volt battery and a voltage stabilizer. Do not omit to connect the cover of the stabilizer to earth. During testing, the stabilizer must lie in the same position as it does in the car. A damaged stabilizer must be replaced by a new unit since it cannot be repaired.

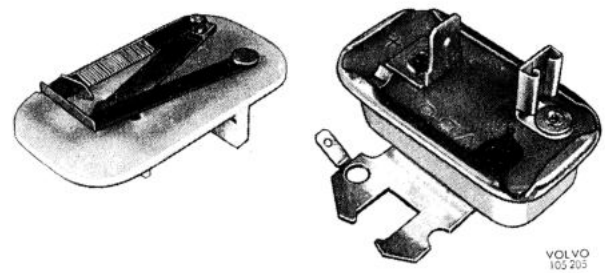

Fig. 3-101. Voltage stabilizer