



SERVICE MANUAL

VOLVO 164 1971

Part 7

SPRINGS, SHOCK ABSORBERS, WHEELS



CONTENTS

Group 70. General	
Tools	7:1
Group 73. Springs	
Description	7:2
Repair Instructions	7:3
Front springs	7:3
Rear springs	7:3
Group 76. Shock Absorbers and Stabilizing Devices	
Description	7:5
General	7:5
Shock absorbers	7:5
Repair Instructions	7:6
Checking shock absorbers	7:6
Replacing front shock absorbers	7:6
Replacing rear shock absorbers	7:7
Replacing support arm bushes	7:7
Replacing track bar bushes	7:8
Replacing support stay bushes	7:9
Group 77. Wheels	
Repair Instructions	7:10
Changing wheels	7:10
Replacing wheel studs	7:10
Replacing and adjusting front wheel bearings	7:10

GROUP 70
GENERAL
TOOLS

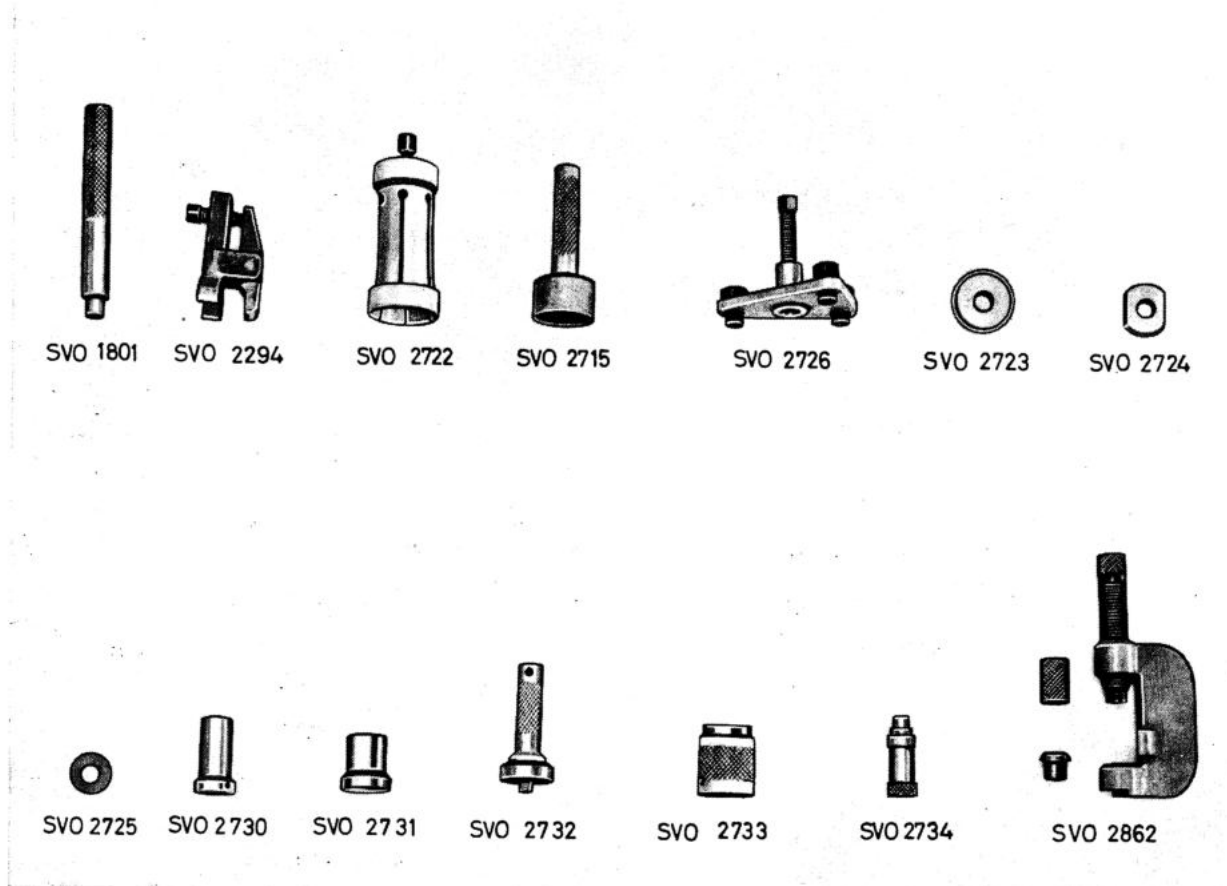

Fig. 7-1. Tools used for work on the rear axle suspension and hub

- SVO 1801 Standard handle 18×200 mm.
- SVO 2294 Puller for ball joint, steering rod.
- SVO 2715 Drift for removing and fitting grease cap.
- SVO 2722 Puller for inner ring, inner wheel bearing.
- SVO 2723 Drift for fitting outer ring, inner front wheel bearing and seal.
- SVO 2724 Drift for fitting outer ring, outer front wheel bearing, and removing outer ring, inner wheel bearing.
- SVO 2725 Drift for removing outer ring, outer front wheel bearing.
- SVO 2726 Puller for front wheel hub.
- SVO 2730 Drift for removing and fitting small bush, track bar and rear bush in support arm (+ SVO 2733).
- SVO 2731 Drift for removing and fitting large bush, track bar (+ SVO 2733).
- SVO 2732 Drift for removing and fitting front bush, support arm.
- SVO 2733 Counterhold for removing and fitting bush, support arm, support stay and track bar.
- SVO 2734 Drift for removing bush in support stay.
- SVO 2862 Press tool for replacing wheel bolt.

VOLVO
104 284

GROUP 73

SPRINGS

DESCRIPTION

The Volvo 164 is provided with coil springs at both front and rear. The front wheel suspension is independent. The upper ends of the front springs (1, Fig. 7-2) are seated in housings formed in the front axle member, and are seated in the bottom of the lower wishbones. The lower wishbones are also provided with rubber buffers (5), which absorb any impacts arising from loading on the spring. The front

axle member is fitted with rubber buffers (4) which limit the downward movements of the wishbones.

The upper ends of the rear springs (5, Fig. 7-5) are bolted to the rear side-members (8) and at the lower ends to the support arms (15) behind the rear axle. Rubber buffers (4) fitted on the rear side-members take up any impacts from loading on the springs.

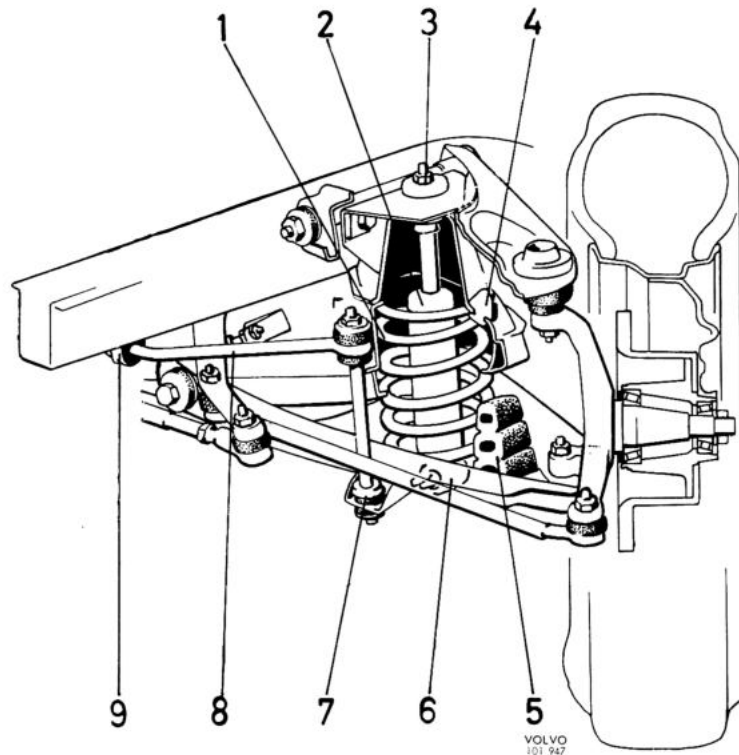

Fig. 7-2. Front spring and shock absorber

1. Spring
2. Shock absorber
3. Upper shock absorber attachment
4. Rubber buffers
5. Rubber buffers
6. Lower shock absorber attachment
7. Attachment for stabilizer
8. Stabilizer
9. Attachment (in frame) for stabilizer

REPAIR INSTRUCTIONS

FRONT SPRINGS

REMOVING

1. Remove the hub cap and loosen the wheel nuts a couple of turns.
2. Jack up the front end at the front jack attachments. Remove the wheel.
3. Remove the shock absorber according to the instructions given in Group 76.
4. Disconnect the steering rod from the steering arm. Loosen the clamp for the brake hoses. Remove the attachment (7, Fig. 7-2) for the stabilizer.
5. Place a jack under the lower wishbone. Loosen the nuts for the ball joints, knock with a hammer until the ball joints loosen from the the knuckle. Remove the nuts and lower the jack slightly. Remove the steering knuckle with the front wheel brake unit and place it on a suitable stand.
6. Lower the jack fully and remove the spring.

FITTING

1. Place the rubber spacer and spring in position. With the jack (placed immediately under the spring) lift up the lower wishbone and fit the steering knuckle.
2. Tighten the ball joints at the steering knuckle. Firmly screw the stabilizer to the lower wishbone.
3. Check the rubber bush and lower washer (1, and 7, Fig. 7-7) of the upper shock absorber attachment. Place the shock absorber in position and tighten its attachment.
4. Point the wheels straight forwards (with the lower wishbone unloaded) and clamp firmly the brake hoses to the screw of the stabilizer.
5. Fit the wheel and wheel nuts. Lower the vehicle. Tighten the nuts.

REAR SPRINGS

REMOVING

1. Remove the hub cap and loosen the wheel nuts a couple of turns. Jack up the vehicle. Place axle props in front of the rear jack attachments according to Fig. 7-4. Remove the wheel.
2. Jack up the rear axle with the jack so that the spring compresses. Loosen the upper and lower spring attachments.
3. Remove the upper attachment (9, Fig. 7-5) for the shock absorber. Lower the jack carefully and remove the spring.

FITTING

1. Fit the upper screw and the washer inside the

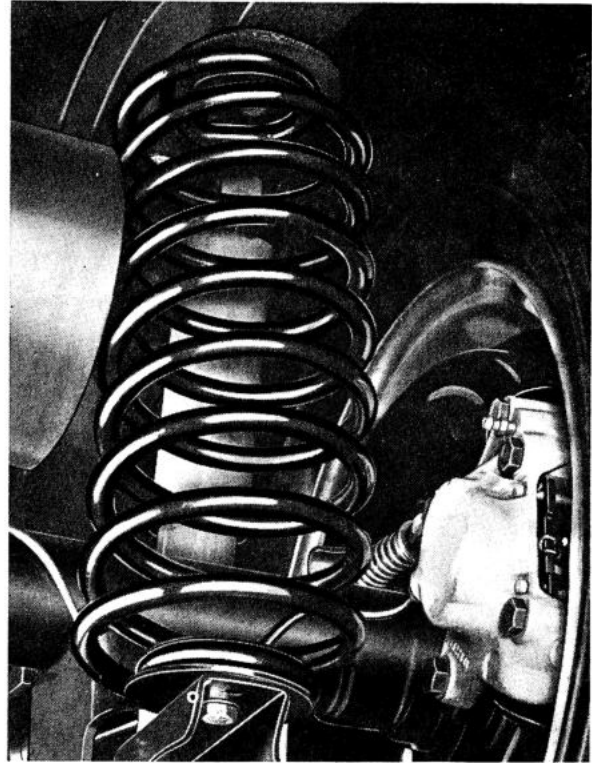

Fig. 7-3. Rear spring

VOLVO
101 906

- spring as well as the rubber spacer (11) and the washer (10) and then firmly secure the spring to the upper attachment.
2. Raise the jack and securely fix the spring to the lower attachment with the washer (14) and the screw (13).
 3. Fit the upper shock absorber screw, the wheel and the wheel nuts.
 4. Lower the vehicle and tighten the wheel nuts. Fit the hub cap.

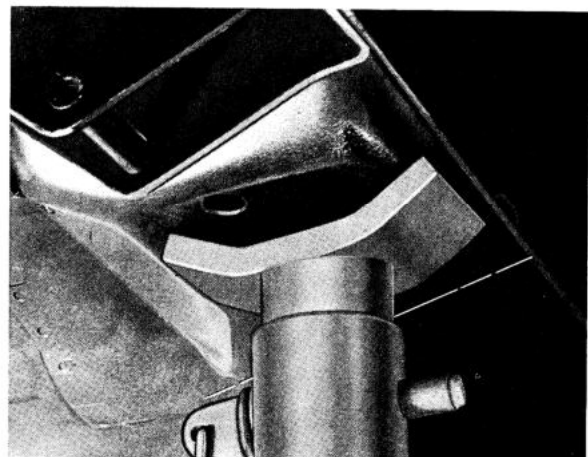

Fig. 7-4. Location of the axle prop for propping up the vehicle rear end

VOLVO
101 906

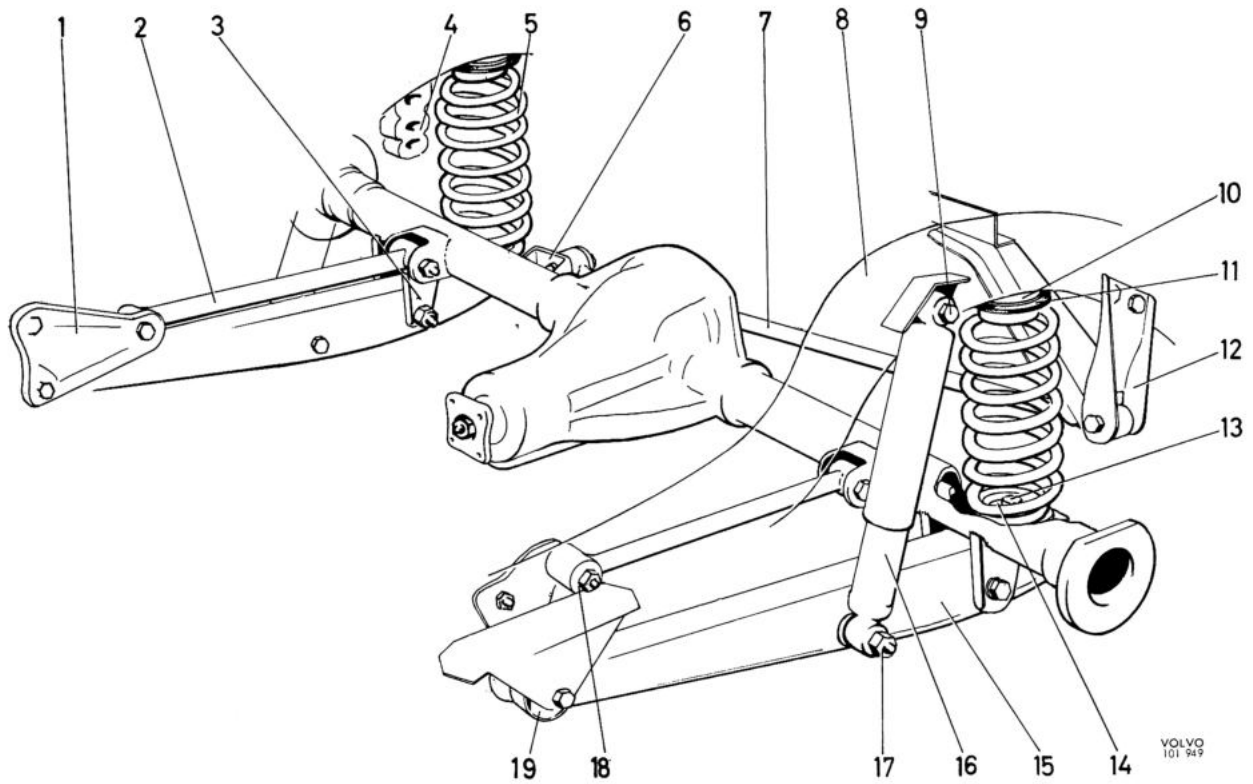

Fig. 7-5. Rear axle suspension

- | | |
|------------------------------------|-------------------------------------|
| 1. Bracket | 11. Rubber spacer |
| 2. Support stay | 12. Bracket |
| 3. Bracket | 13. Screw lower spring attachment |
| 4. Rubber buffer | 14. Washer |
| 5. Rear spring | 15. Support arm |
| 6. Bracket | 16. Shock absorber |
| 7. Track bar | 17. Lower shock absorber attachment |
| 8. Rear side-member | 18. Front support stay attachment |
| 9. Upper shock absorber attachment | 19. Front bush, support arm |
| 10. Washer | |

SHOCK ABSORBERS AND STABILIZING DEVICES

DESCRIPTION

GENERAL

The 164 is fitted with hydraulic, double-acting, telescopic type shock absorbers. They require no maintenance and cannot be dismantled.

The front shock absorber upper attachment (Fig. 7-7) consists of a spindle (5), which with upper bushes (1 and 6), washers (3 och 7) and a spacing sleeve, are fixed into a housing in the front axle member.

The lower attachment (Fig. 7-8) consists of an eyelet provided with a rubber bush, which cannot be dismantled and a piece of tubular piping, the flattened ends of which are screwed to the bottom side of the lower wishbone.

The stabilizer (8, Fig. 7-2), which is attached to both the lower wishbones (7) and to the frame (9), increases the stability of the vehicle.

The rear shock absorber attachment (Fig. 7-9) consists of eyelets provided with rubber bushes (1 and 3) which cannot be dismantled. These absorbers are bolted at the top to the rear side-members and at the bottom to the support arms.

The rear axle is attached to the body through two flexibly mounted support arms (15, Fig. 7-5). Forces acting longitudinally are taken up by two support stays (2) and the lateral forces are absorbed by a track bar (7). The support arms are fore-mounted in rubber bushes (19). The support stays and track bar are attached to the rear axle frame through the rubber bushes.

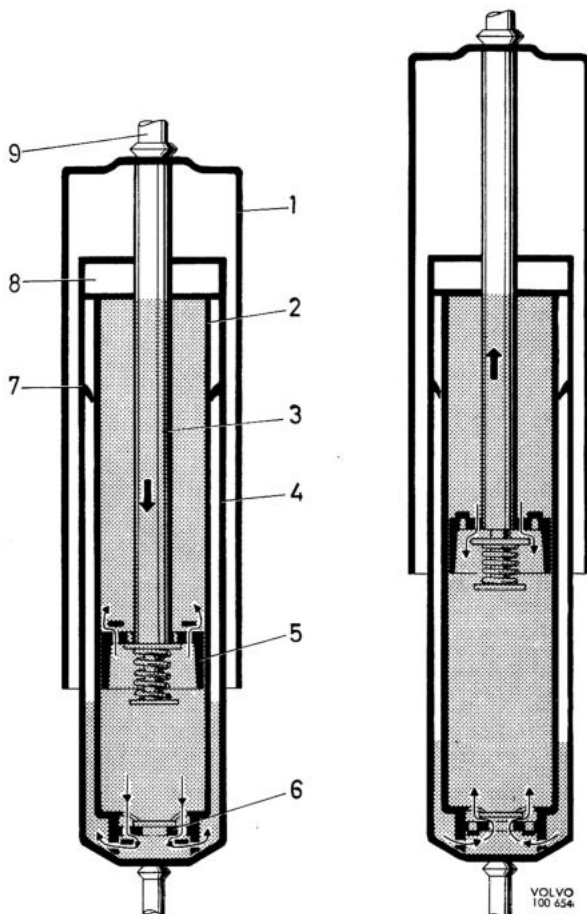

Fig. 7-6. Shock absorber, function

- | | |
|-----------------------|---------------------|
| 1. Dust cover | 6. Valve |
| 2. Working cylinder | 7. Baffle ring |
| 3. Piston rod | 8. Cover |
| 4. Reservoir cylinder | 9. Upper attachment |
| 5. Piston | |

SHOCK ABSORBERS

DESIGN

The design of the shock absorbers is shown in Fig. 7-6. The outer cylinder (1) serves only as a protection against dust and dirt. The other two cylinders (2 and 4) are concentrically arranged, one inside the other. The inner cylinder (2) is the actual working cylinder, the lower end of which is provided with a valve (6). Inside the inner cylinder there is a piston (5) in which holes are drilled, the passage of oil through these holes being controlled by valves.

The piston is attached to a piston rod (3), the upper end of which forms an attachment to the body. At the opposite end of the shock absorber a similar screw attachment is fitted. The space between the cylinders (2 and 4) serves as a reservoir and is only partially filled with fluid. The inner cylinder (2) is completely filled with fluid on both sides of the piston (5). The cover (8) serves as a seal and guide for the piston rod (3). The baffle ring (7) acts as a baffle for the fluid.

FUNCTION

When the shock absorber is compressed or extended through the suspension of the vehicle, the piston (5) is moved in the inner cylinder (2). Fluid then flows through the valve-controlled holes in the piston. The speed with which the piston moves is determined by the rate at which the fluid passes through the holes from one side of the piston to the other. Since the drilled holes are very narrow, the fluid can only pass through slowly, thus braking the movement of the piston. When the shock absorber is suddenly compressed or extended, a further braking effect is

caused by turbulence in the fluid passing through the holes in the piston. This dampens any rolling tendency on the part of the vehicle and ensures smoother riding.

When the shock absorber is compressed or extended, the volume on each side of the piston is not altered by the same amount since the piston rod occupies a certain space. When the shock absorber is compressed, therefore, some of the fluid passes out through the valve (6) into the reservoir, and when the shock absorber is extended, fluid is again sucked into the cylinder (2) on the underside of the piston.

REPAIR INSTRUCTIONS

CHECKING THE SHOCK ABSORBERS

Accurate checking of the shock absorbers can only be carried out with special checking devices. A rough check, however, can be made in order to see that the shock absorbers are functioning on the whole by noting the damping effect when rocking the car up and down and then releasing it. Testing can also be carried out by driving the vehicle over a bumpy surface. The removed absorber can be tested by tightly fixing the lower attachment in a position similar to that when fitted in the vehicle. If it is then alternately pulled out and compressed; it is possible to judge whether it is operating or not. Notice on making this check that, when the shock absorber is extended, its resistance is three times as great as when it is compressed, this due to its way of operating.

If the shock absorber does not function satisfactorily in both directions, or if the fixed rubber bushes are damaged, the shock absorbers should be replaced.

REPLACING FRONT SHOCK ABSORBERS

1. Remove the upper nut (4, Fig. 7-7), the washer (3) and the rubber bush (6).
2. Remove the two lower attaching screws (Fig. 7-8)

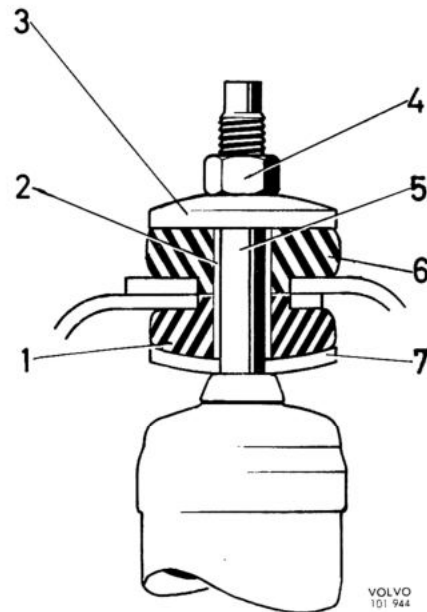

Fig. 7-7. Upper attachment, front shock absorber

- | | |
|-------------------|----------------|
| 1. Rubber bush | 5. Spindle |
| 2. Spacing sleeve | 6. Rubber bush |
| 3. Washer | 7. Washer |
| 4. Nut | |

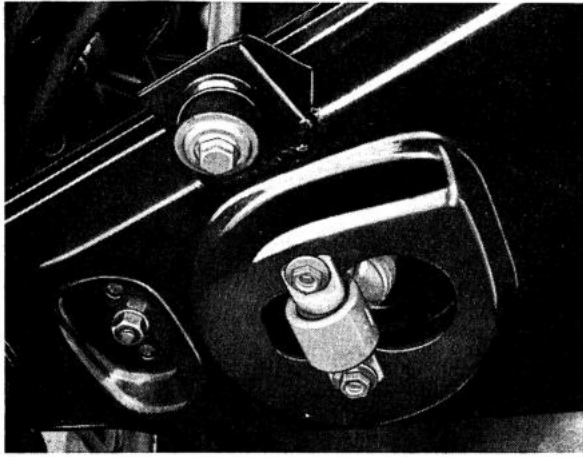

Fig. 7-8. Lower attachment, front shock absorber

on the underside of the lower wishbone, and take down the shock absorber.

3. Fit the washer (7), the spacing sleeve (2) and the rubber bush (1).
4. Pull apart the shock absorber and then fit it. Fit and tighten the lower screws.

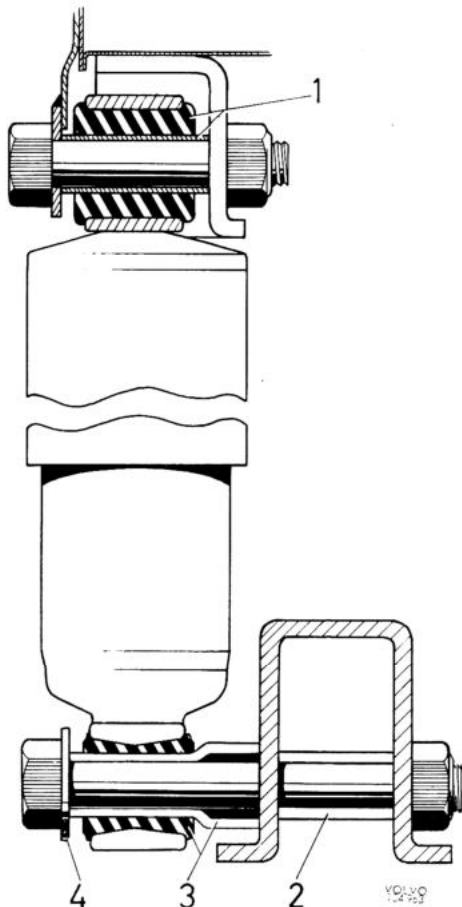

Fig. 7-9. Attachments, rear shock absorber

- | | |
|-------------------|-----------|
| 1. Bush | 3. Bush |
| 2. Spacing sleeve | 4. Washer |

5. Fit the upper rubber bush (6), the washer (3) and the nut. Tighten the nut until it makes firm contact with the spacing sleeve.

REPLACING REAR SHOCK ABSORBERS

1. Remove the hub cap. Slacken the wheel nuts a couple turns. Jack up the rear end of the vehicle at the jack attachments. Place blocks in front of the jack attachments according to Fig. 7-4. Remove the wheel. Unscrew and remove the shock absorber.
2. When fitting make sure that the spacing sleeve in the support arm has not been removed (2, Fig. 7-9). Fit and tighten the shock absorber. Fit the wheel and wheel nuts. Lower the vehicle. Put on the hub cap.

REPLACING BUSHES FOR THE SUPPORT ARM

1. Raise the vehicle by placing props in front of the rear jack attachments according to Fig. 7-4. Do not remove the jack.
2. Disconnect the shock absorber at the lower attachment. Remove the lower screw of the spring and then lower the jack until the spring releases from the support arm. Move the spring backwards so that it runs free from the support arm. Raise the jack until the rear axle is in a level position.
3. Remove the screw on the support arm at the rear axle bracket (3, Fig. 7-5). Remove the front screw and take off the support arm.
4. Press out the front bush with tool SVO 2732. Coat the new bush with **oil** and press it in with the same tool according to Fig. 7-10. Make sure that the plane sides of the bush are at right angles to the support arm shaft (Fig. 7-10).
5. Press out the rear bush with tool SVO 2730 and tool SVO 2733.
Press in the new bush with the same tools, using tool SVO 2730 in the reverse direction.
6. Place the support arm in position and fit the front and rear screws.
7. Lower the jack under the rear axle, move the spring in position on the support arm, again raise the rear axle to the horizontal position and fit the lower screw for the spring.
8. Fit and tighten the nuts for the support arm screws. Fit and tighten the screw for the lower shock absorber attachment.

N.B. Check that the spacing sleeve and washers are placed correctly, see Fig. 7-9. Remove the props from under the vehicle and lower it.



Fig. 7-10. Removing (and fitting) the front bush, support arm

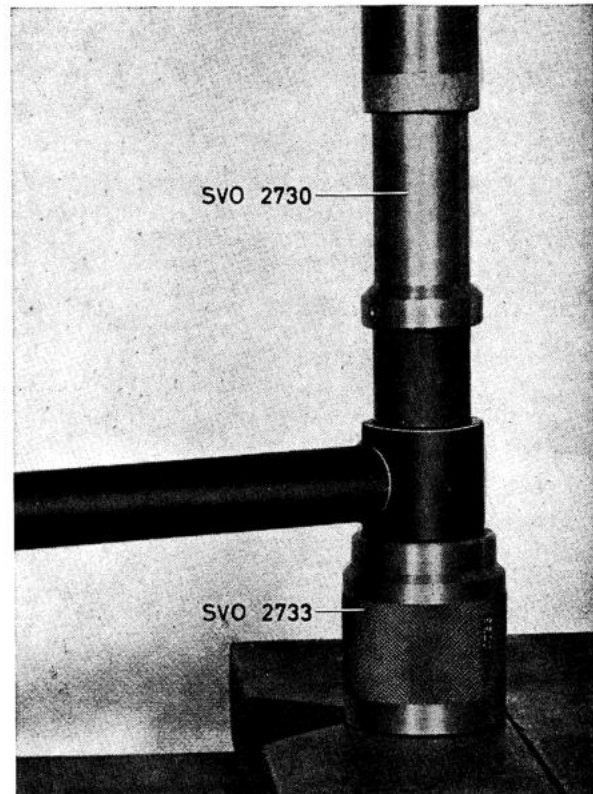

Fig. 7-12. Fitting the small bush, track bar

REPLACING BUSHES FOR THE TRACK BAR

1. Raise the rear end of the vehicle by placing props in front of the rear shock absorber attachments according to Fig. 7-4.
2. Remove the nuts at both brackets (6 and 12, Fig. 7-5). Remove the track bar from the bracket mounted on the rear axle. Remove the screw at the bracket (12) attached to the frame and take off the track bar.
3. Check the bushes and make sure that the bar is not bent.
4. If necessary, press out the small bushes with SVO 2730 using SVO 2733 as a counterhold (Fig. 7-13). Pressing in the bushes can be done with the same tools only in this case SVO 2730 is reversed (Fig. 7-14).

5. The large bushes are pressed out with SVO 2731, and SVO 2733 as a counterhold (Fig. 7-11). When pressing in the bushes, SVO 2731 is reversed (Fig. 7-12).
6. Fit the bar with the screw to the frame bracket (12).
7. Place the other end on the rear axle bracket (6) and fit both washer and nut. Screw on the frame bracket nut.
8. Remove the blocks and lower the vehicle.

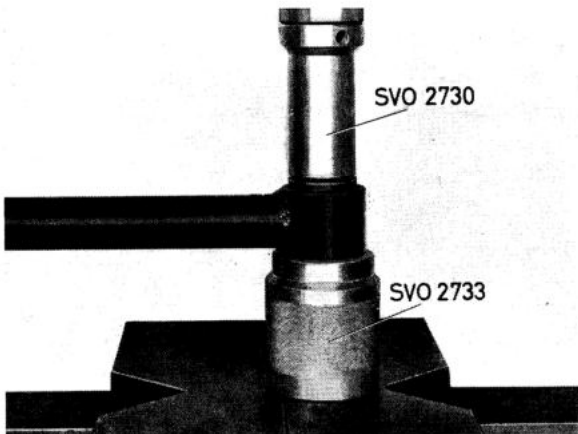

Fig. 7-11. Removing the small bush, track bar

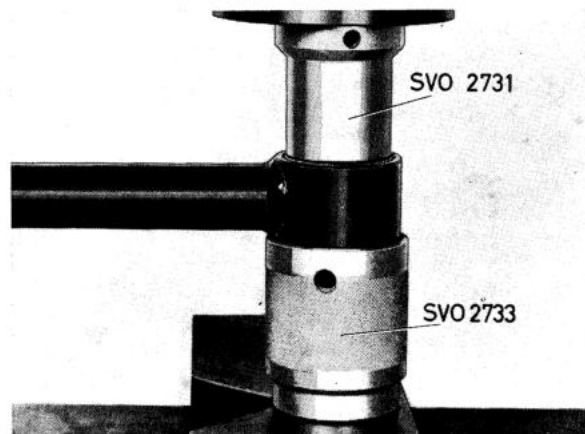

Fig. 7-13. Removing the large bush, track bar

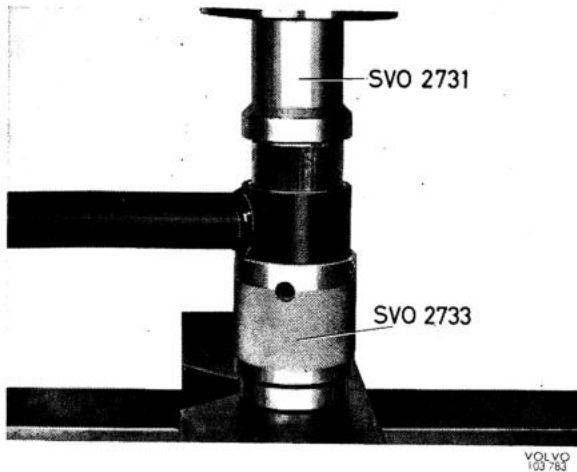

Fig. 7-14. Fitting the large bush, track bar

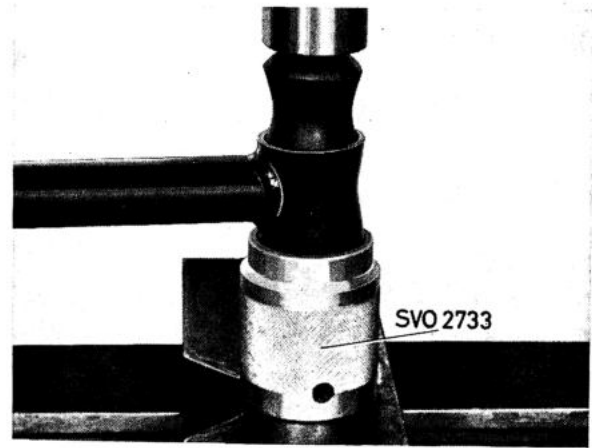

Fig. 7-15. Fitting the bush, support stay.

REPLACING BUSHES FOR THE SUPPORT STAY

The bushes of the support stay are pressed out with tool SVO 2734 and counterhold SVO 2733. They are suitably pressed in with a drift press directly on the bush and with tool SVO 2733 as a counterhold (see Fig. 7-15). Before pressing in the rubber bush, coat it with oil so that it slides easily in position and is not damaged.

When fitting the bushes, they should be turned so that the markings come at right angles to the length of the stay as shown by the arrows in Fig. 7-16.

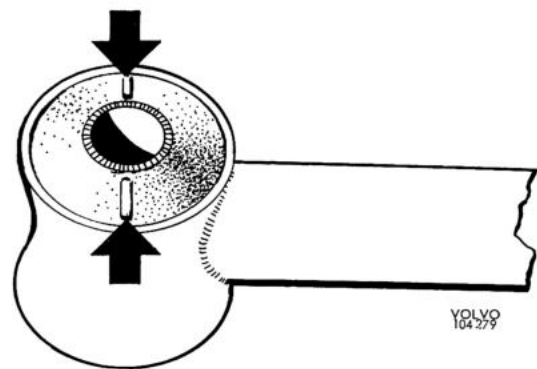

Fig. 7-16. Marking up the support stay bush

WHEELS

REPAIR INSTRUCTIONS

CHANGING WHEELS

When fitting wheels, it is important that all grit and dirt and any surplus paint is cleaned off from the contact surfaces between wheel and hub.

REPLACING THE WHEEL STUDS

The wheel studs can be replaced without removing the front wheel hubs or drive shafts.

1. Remove the brake caliper and brake disc according to the instructions in Part 5.
2. Set up tool SVO 2862, without the accessory

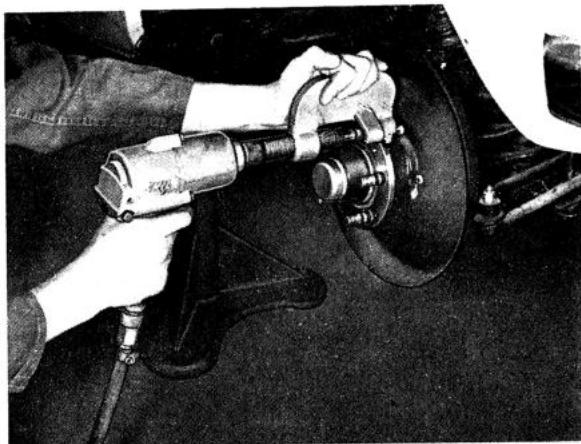

VOLVO
104306

Fig. 7-17. Removing the wheel stud

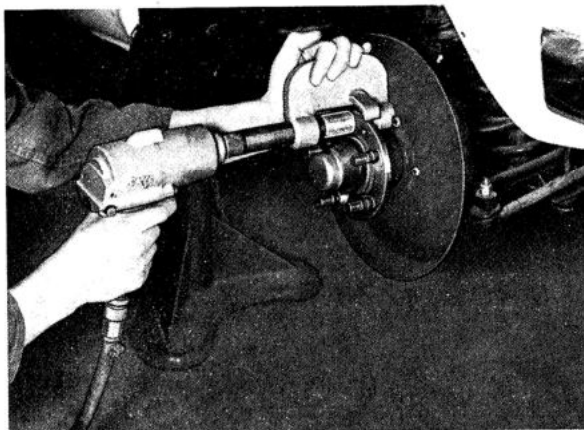

VOLVO
104307

Fig. 7-18. Fitting the wheel stud

components, as shown in Fig. 7-17. Run the nut runner until the stud is fully removed. If the old stud is loose in the hub, the hole must be checked. If the hole diameter exceeds 16.27 mm (0.64"), the hub must be replaced.

3. Insert a new, oversize wheel stud and press it in by hand as far as possible.
 4. Place the accessory part, the pin, in the press tool.
 5. Place the sleeve on the outer end of the wheel stud.
 6. Place the tool in position (see Fig. 7-18) and use a nut runner to screw in the stud completely.
- N. B. When replacing a wheel stud, always use a new, oversize stud. The oversize stud can be fitted without previously machining the hole.

REPLACING AND ADJUSTING FRONT WHEEL BEARINGS

1. Remove the hub cap and slacken the wheel nuts slightly.
2. Jack up the front end and place props under the lower wishbones. Unscrew the wheel nuts and lift off the wheel.
3. Remove the front wheel brake according to the instructions given in Part 5 under "Removing the front wheel brake unit".
4. Remove the grease cap with tool SVO 2715 (Fig. 7-19). Remove the split pin and castle nut. Pull off

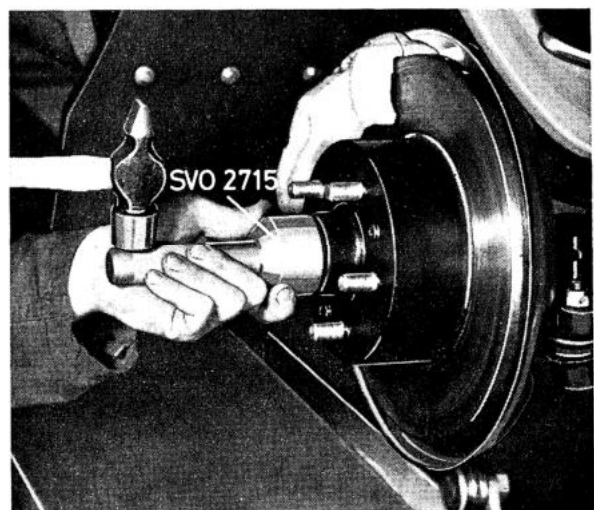

VOLVO
102906

Fig. 7-19. Removing the grease cap

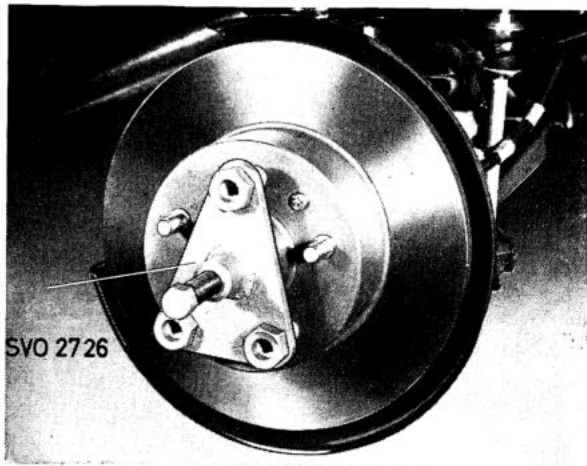

Fig. 7-20. Removing the hub

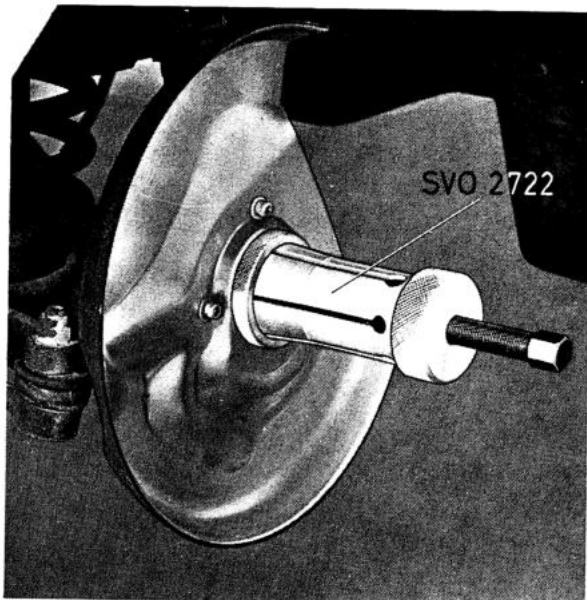

Fig. 7-21. Removing the inner bearing

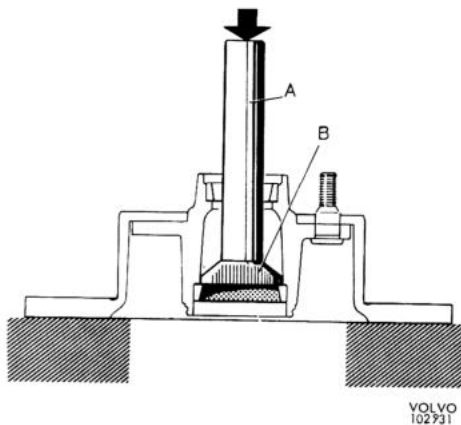

Fig. 7-22. Removing the inner bearing ring
A = SVO 1801 B = SVO 2724

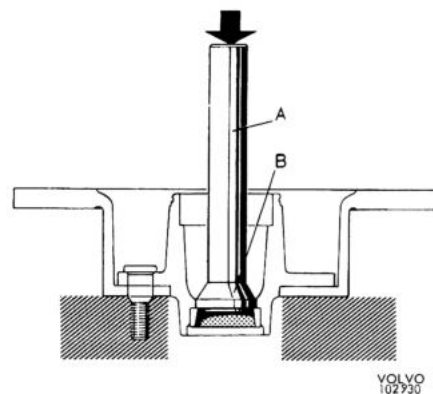
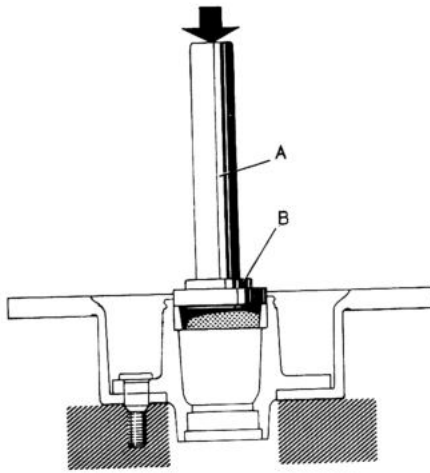

Fig. 7-23. Removing the outer bearing ring
A = SVO 1801 B = SVO 2725

the hub with puller SVO 2726 (see Fig. 7-20). Pull off the inner bearing from the stub axle with puller SVO 2722 (see Fig. 7-21) if the bearing remains in place.

5. Remove the bearing rings. Use drift SVO 2724 (Fig. 7-22) for the inner bearing ring and drift SVO 2725 (Fig. 7-23) for the outer bearing ring together with standard handle SVO 1801.
 6. Clean the hub, brake disc and grease cap.
 7. Press in the new bearing rings. In addition to using standard handle SVO 1801, use drift SVO 2723 (Fig. 7-24) for the inner ring, and drift SVO 2724 (Fig. 7-25) for the outer bearing ring.
 8. Grease the bearing with the help of a pressure greaser. If there is not one available, pack the bearings by hand with as much thick grease as there is room for between the roller retainer and inner ring of the bearing. Also apply grease to the outer sides of the bearings and on the outer rings pressed into the hub. The recess in the hub is filled with grease all round up to the smallest diameter of the outer ring of the outer bearing, see Fig. 7-27.
- Use a high-class bearing grease for the bearing. Place the inner bearing in position in the hub. Press in the seal with drift SVO 2723 and standard handle SVO 1801, see Fig. 7-26.
- The felt ring should be well coated with, for example, light engine oil.
- 9 Place the hub on the stub axle. Fit the outer bearing, washer and castle nut.
 10. The front wheel bearings are adjusted by first tightening the nut with a torque wrench to a torque



VOLVO
102929

Fig. 7-24. Fitting the inner bearing ring
A = SVO 1801 B = SVO 2723

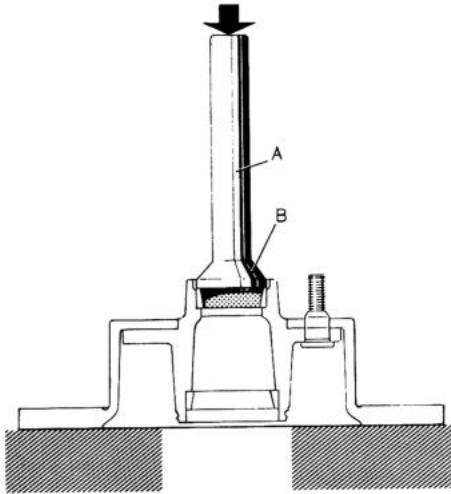

VOLVO
102928

Fig. 7-25. Fitting the outer bearing ring
A = SVO 1801 B = SVO 2724

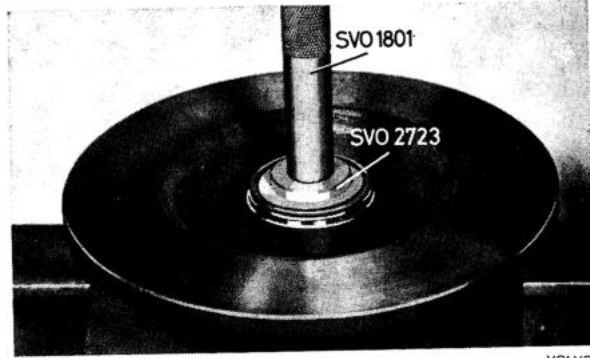

VOLVO
102907

Fig. 7-26. Fitting the seal

of 7 kgm (50 lb.ft.). Then slacken the nut 1/3 of a turn. If the slot in the nut does not coincide with the split pin hole in the stub axle slacken it further to enable the split pin to be fitted. Check that the wheel rotates easily without any play.

11. Fill the grease cap half full of grease and fit it with tool SVO 2715.
12. Fit the front wheel brake unit according to Part 5.
13. Lift on the wheel after having cleaned any grit and dirt from the contact surfaces between the wheel and hub, and then tighten up the nuts sufficiently so that the wheel cannot be displaced on the hub. Lower the vehicle and tighten the wheel nuts firmly. Tighten every other nut a little at a time until all of them are finally tightened to a torque of 10—14 kgm (70—100 lb.ft.). Fit the hub cap.

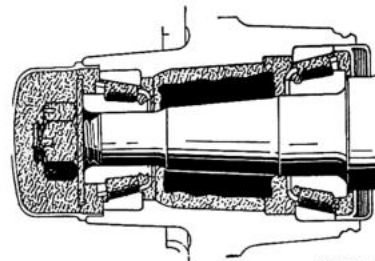

VOLVO
23808

Fig. 7-27. Lubrication of front bearing