

1

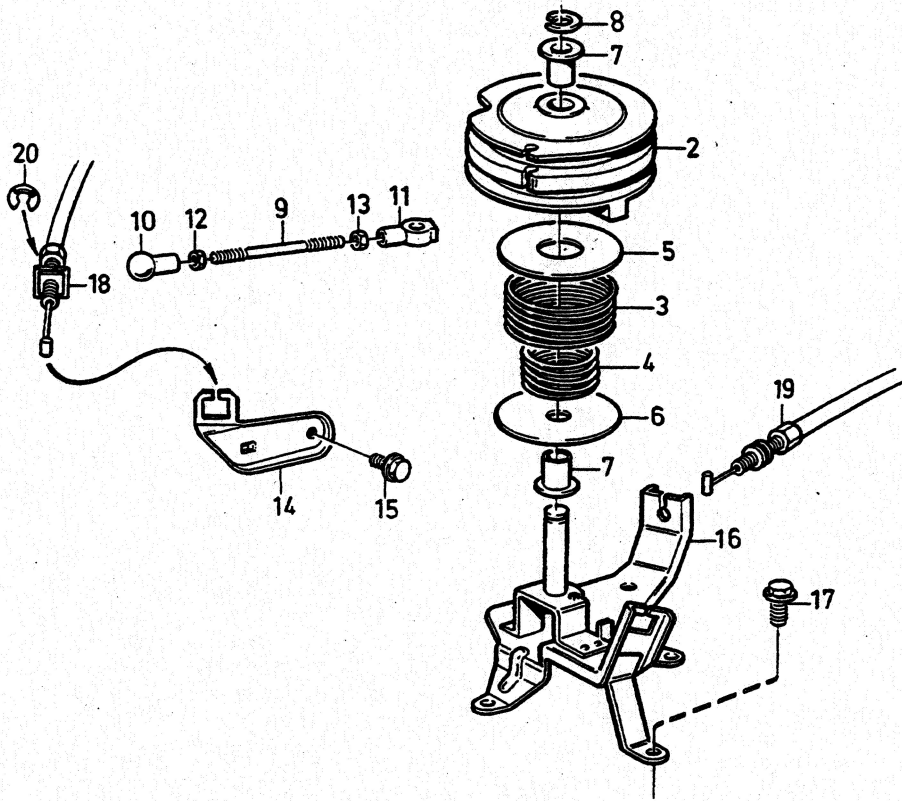

VOLVO
Genuine Parts
PV 270 47339

A	B	C	D	E	CONTROL PULLEY WITH FITTINGS		REGLAGERULLE MED MONTERINGSDETALJER		Group		
					B200K, B230K		Grupp				
										27	
										Page	
										Sida	
										275	
Fig	Part No. Artikel nr	Quantity / Antal					P S	Description	Benämning	Notes Anmärkning	S R
		A	B	C	D	E					
1	1389250-0	1	-	-	-	-		Control bobbin complete	Reglagerulle komplett		4
2		1	-	-	-	-	NS	• Control bobbin	• Reglagerulle		
3	1306244-3	1	-	-	-	-		• Spring	• Fjäder		2
4	1269342-0	1	-	-	-	-		• Spring	• Fjäder		2
5	1306245-0	1	-	-	-	-		• Spring guide	• Fjäderstyrning		3
6	1306246-8	1	-	-	-	-		• Spring guide	• Fjäderstyrning		3
7	1276512-9	2	-	-	-	-		• Bushing	• Bussning		2
8	951669-1	1	-	-	-	-		• E-circlip	• Spärryttare		2
9	943315-2	1	-	-	-	-		Control rod	Reglerstång		2
10	946704-4	1	-	-	-	-		Ball socket left-hand thread ...	Kulskål vänstergängad		3
11	946703-6	1	-	-	-	-		Ball socket	Kulskål		3
12	973447-6	1	-	-	-	-		Nut left-hand thread	Mutter vänstergängad		2
13	965483-1	1	-	-	-	-		Flange nut	Flänsmutter	(968898)	2
14	1357210-2	1	-	-	-	-		Bracket	Konsol	R.H.D	4
15	948746-3	3	-	-	-	-		Flange screw	Flänsskruv	R.H.D	2
16		1	-	-	-	-	NS	Bracket	Konsol		
17	948746-3	3	-	-	-	-		Flange screw	Flänsskruv		2
18		1	-	-	-	-		Throttle control cable	Gasreglagewire	SEE 27-273	
19		1	-	-	-	-		Cable	Kabel	SEE 43-515	
20	947515-3	1	-	-	-	-		E-circlip	Spärryttare		2