

# Servicehandboek

## Reparatie en onderhoud

deel 3 (39)

Aansluitschema's  
bedrading

240 1975, 1976

# VOLVO

## INHOUDSOPGAVE

Zo moet U de schema's gebruiken .....	1
Group 24 Benzine-inspuiting 1975 .....	2
Benzine-inspuiting 1976 .....	3
Groep 32 Stroomvoorziening .....	4
Groep 33 Startstelsysteem .....	5
Groep 34 Ontstekingsstelsysteem zonder contactpunten .....	6
Ontstekingsstelsysteem met contactpunten .....	7
Groep 35 Groot- en dimlicht .....	8
Stads- en achterlichten .....	9
Kentekenplaatverlichting 245 .....	10
Rijlichten .....	11
Stoplichten .....	12
Achteruitrijlichten, handgeschakelde versn. bak .....	13
Achteruitrijlichten, automatische versn. bak .....	14
Relais voor defecte gloeilampen .....	15
Verlichting instrumenten en bedieningsorganen .....	16
Verlichting handschoenenkastje .....	17
Interieurverlichting .....	18
Interieurverlichting, 245 achter .....	19
Motorruimteverlichting .....	20
Groep 36 Richtingaanwijzers en waarschuwingsknipperlichten .....	21
Claxon .....	22
Ruitwissers en -sproeiers .....	23
Koplampwissers en -sproeiers .....	24
Ruitwischer en -sproeier achterrait .....	25
Overdrive .....	26
Sigaretteaansteker .....	27
Luchtaanjager, standaardverwarming .....	28
Luchtaanjager, gecombineerde verw.stelsysteem .....	30
Elektrisch verwarmde bestuurdersstoel .....	30
Elektrisch verwarmde achterrait, 242-244 .....	31
Elektrisch verwarmde achterrait, 245 .....	32
Waarschuwinglampje autogordel .....	33
Groep 38 Instrumentenpaneel (met temperatuur- en benzine-meter en toerenteller) ....	34
Klokje .....	35
Groep 85 Airconditioning .....	36
Compleet Bedradingsstelsysteem 1975 .....	37
Compleet Bedradingsstelsysteem 1976 .....	38

Bestellings Nr: TP 11098/2  
 Vervangt vroegere uitgave: TP 11098/1

## VOORWOORD

Doordat het aantal functies en componenten van de elektrische uitrusting van de auto steeds is toegenomen en deze steeds meer taken krijgt opgedragen, zijn tot op heden gemaakte schema's zeer ingewikkeld geworden, zodat men er vaak niet meer uit wijs wordt.

In het voor U liggende boek met schema's presenteren wij de elektrische uitrusting op een andere manier, waardoor het veel gemakkelijker is om een en ander op te zoeken waardoor het gebruik wordt bevordert. Het complete schema

van de elektrische uitrusting is onderverdeeld in delen, die ieder voor zich een apart onderdeel van de elektrische uitrusting behandelen. Iedere functie wordt op een dubbel blad behandeld. De inwendige aansluitingen, aansluitingen aan de buitenkant en de plaats waar het onderdeel in de wagen is aangebracht, zijn hierop afgebeeld. Bovendien is te zien hoe de leidingen in de wagen zijn getrokken, evenals de stroomrichting zoals die onder "normale" omstandigheden is.

Zie verder volgende bladzijde.

## ZEKERINGEN

1975			1976		
Nr	Beveiligt volgende stroomverbruikers	Stroomsterkte	Nr	Beveiligt volgende stroomverbruikers	Stroomsterkte
1	Sigaretteaansteker Koplampwissers Wisser achterraut (245)	8 A	1	Sigaretteaansteker Koplampwissers Wisser achterraut (245)	8 A
2	Ruitwissers Luchtaanjager Claxon	16 A	2	Ruitwissers Luchtaanjager Claxon	16 A
3	Elektrisch verwarmde achterraut Overdrive	16 A	3	Elektrisch verwarmde achterraut Overdrive	16 A
4	Verlichting handschoenenkastje Achteruitrijlichten Elektrisch verwarmde bestuurdersstoel Air-conditioning	8 A	4	Verlichting handschoenenkastje Achteruitrijlichten Elektrisch verwarmde bestuurdersstoel Air-conditioning	8 A
5	Instrumenten Richtingaanwijzers Controle- en waarschuwingslampjes Waarschuwingrelais autogordels	5 A	5	Instrumenten Richtingaanwijzers Controle- en waarschuwingslampjes Relais, injectiemotor Elektromagnetische klep, carburateur Relais lampje autogordels	8 A
6	Waarschuwingknipperlichten Achterste interieur verlichting Motorruimte verlichting	8 A	6	Waarschuwingknipperlichten Achterste interieurverlichting Motorruimte verlichting	8 A
7	Klokje Benzinepomp, injectiemotor	8 A	7	Klokje Benzinepomp, injectiemotor	8 A
8	Remlichten Interieurverlichting	8 A	8	Remlichten Interieurverlichting	8 A
9	Reserve	5 A			
10	Rijlichten	8 A			
11	Linker parkeerlicht Linker kentekenplaatverlichting (245: links en rechts)	5 A			
12	Rechter parkeerlicht Rechter kentekenplaatverlichting Instrumenten- en paneelverlichting	5 A	11	Linker parkeerlicht Linker kentekenplaatverlichting (245: links en rechts)	5 A
			12	Rechter parkeerlicht Rechter kentekenplaatverlichting Instrumenten- en paneelverlichting	8 A

# Zo moet U het

Zoek in de Inhoudsopgave het onderdeel van de elektrische installatie op, dat U wilt onderzoeken. Laten we zeggen dat U de ruitwissers wilt bekijken. Volgens de inhoudsopgave vindt U ruitwissers en -sproeiers op blz 23. Deze slaat U dus op.

Hier ziet U schematisch hoe de componenten op elkaar zijn aangesloten en hoe ze er van binnen uitzien.

De dikte van de leidingen wordt aangegeven in mm<sup>2</sup> en de kleur met hoofdletters:

SB	= zwart	BR	= bruin
GR	= grijs	Y	= geel
W	= wit	BL	= blauw
R	= rood	GN	= groen

In die gevallen, dat bepaalde functies gemeenschappelijk over een zekering zijn geschakeld, wordt dit vermeld om het vinden van een storing te vergemakkelijken.

Voorbeeld:

De ruitwisser werkt niet.

Als de claxon werkt dan zit de storing in of na het zekeringenkastje.

Werkt de claxon niet dan zit de storing waarschijnlijk tussen de accu en het zekeringenkastje.

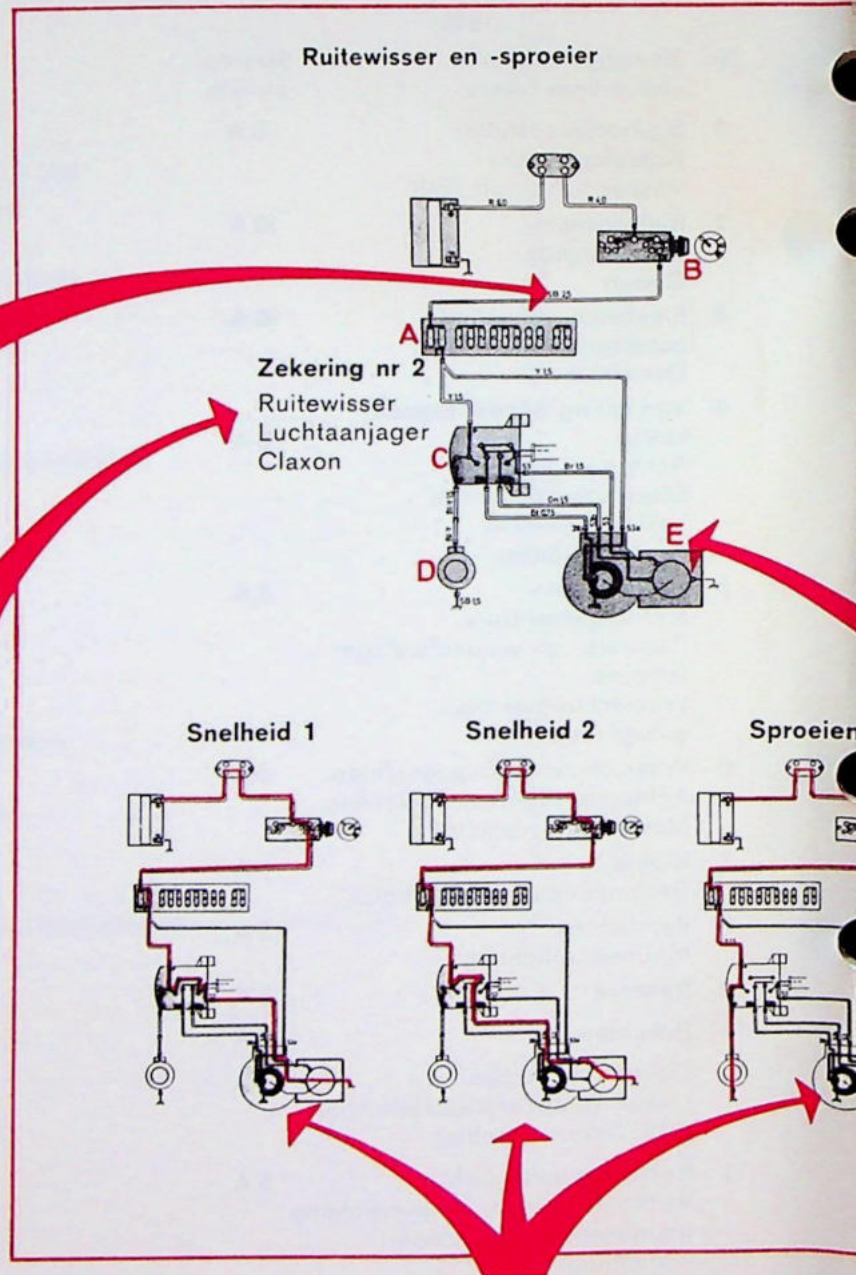

Hier ziet U de stroomrichting onder verschillende omstandigheden.

# schema gebruiken

Begin hier

## Ruitwisser en -sproeier

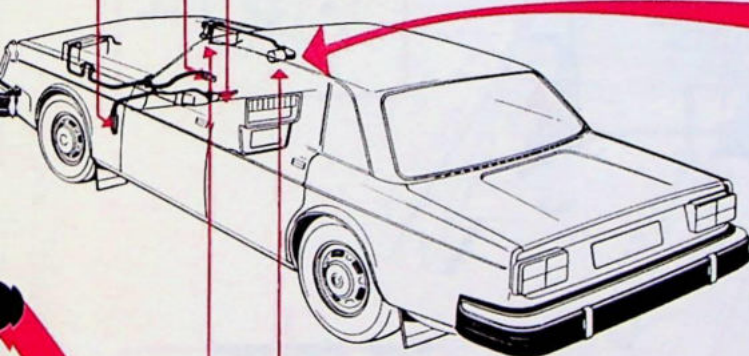
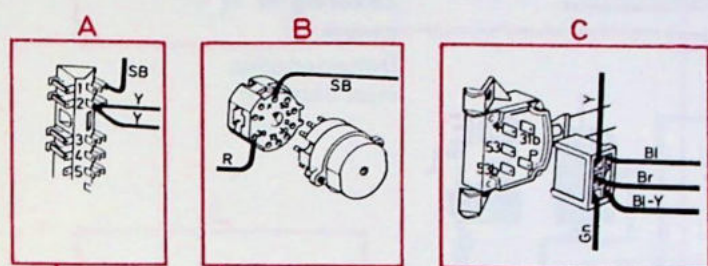

Hier ziet U waar de componenten voor de functie zijn aangebracht.

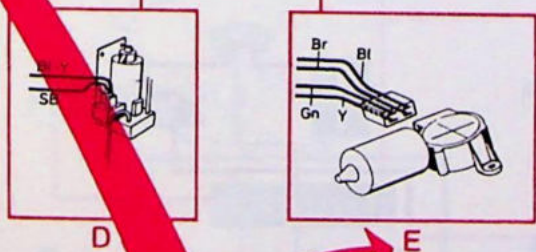

Bovendien ziet U hoe de leidingen zijn getrokken en waarop de betreffende component c.q. leidingen zijn aangesloten.

Met behulp van de hoofdletters vindt U gauw de componenten, die bij het elektrische schema horen.

# Benzine-inspuiting -75

## Zekering nr 4

Verlichting handschoenenkastje  
Achteruitrijlichten  
Elektrisch verwarmde bestuurdersstoel  
Air-conditioning

## Zekering nr 7

Klokje  
Benzinepomp,  
injectiemotor

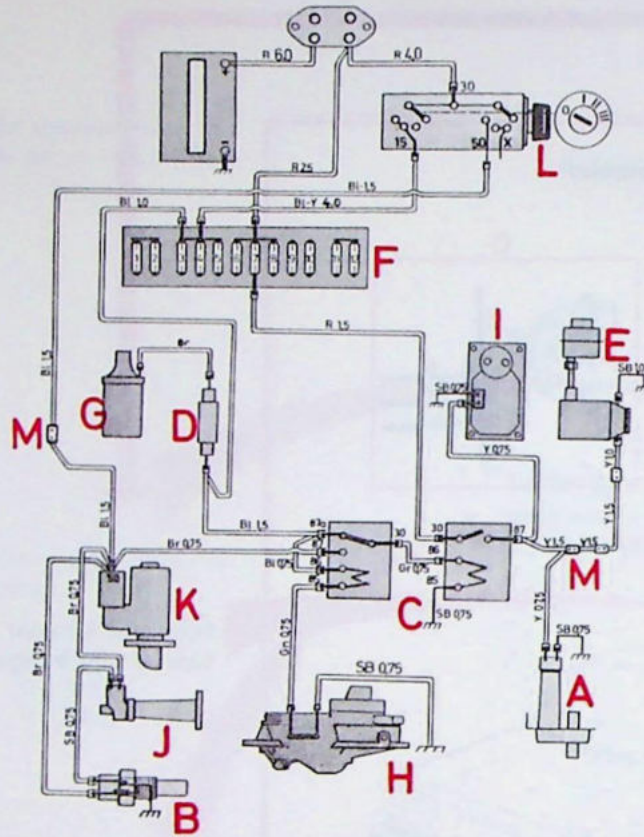

Starten van de motor

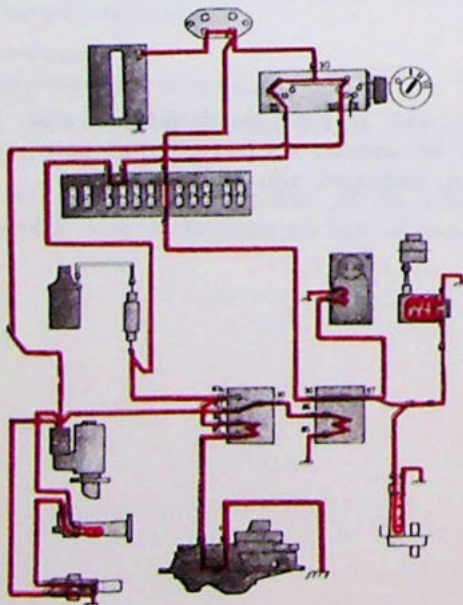

Motor loopt

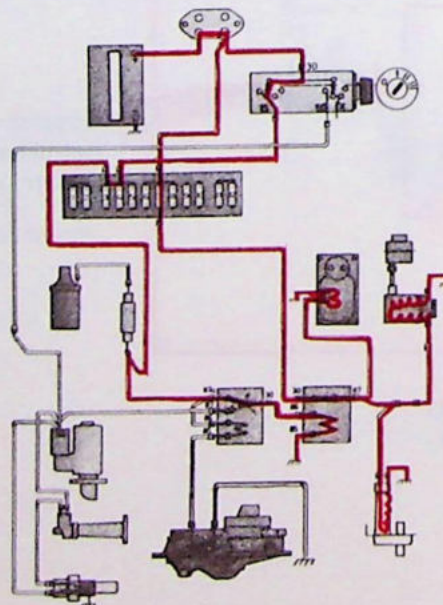

Motor afgeslagen  
(ontsteking ingeschakeld,  
maar motor loopt niet)

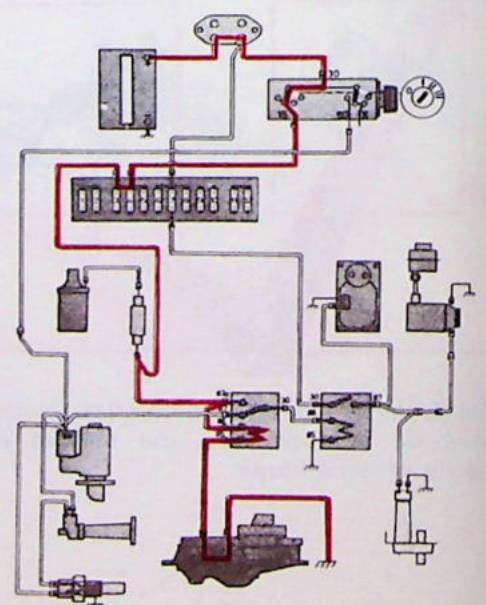

# Benzine-inspuiting -75

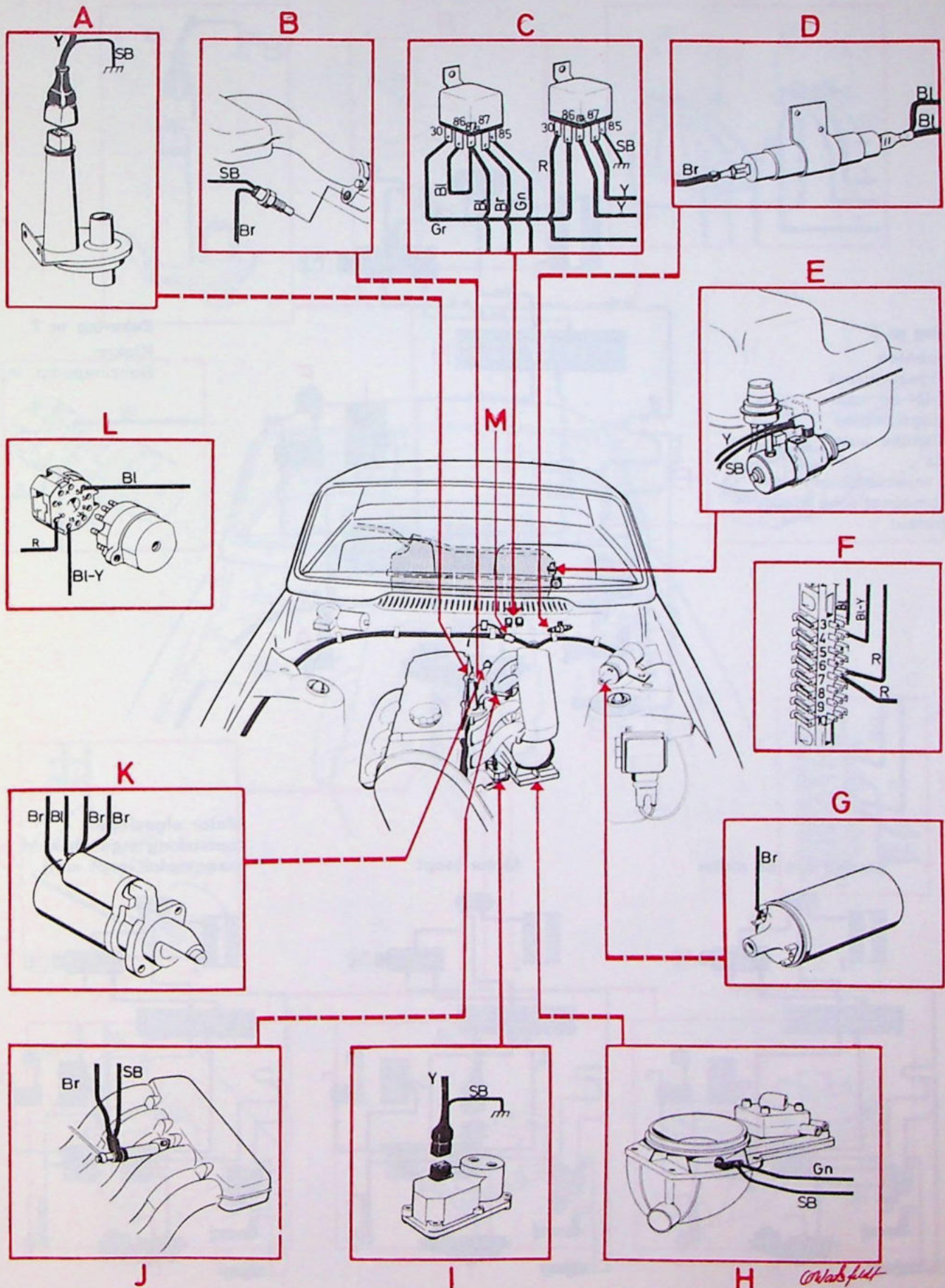

# Benzine-inspuiting -76

**Zekering nr 5**  
 Instrumenten  
 Richtingaanwijzers  
 Controle- en waarschuwingslampjes  
 Relaislampje auto-gordels  
 Relais injectiemotor  
 Elektromagnetische klep, carburateur

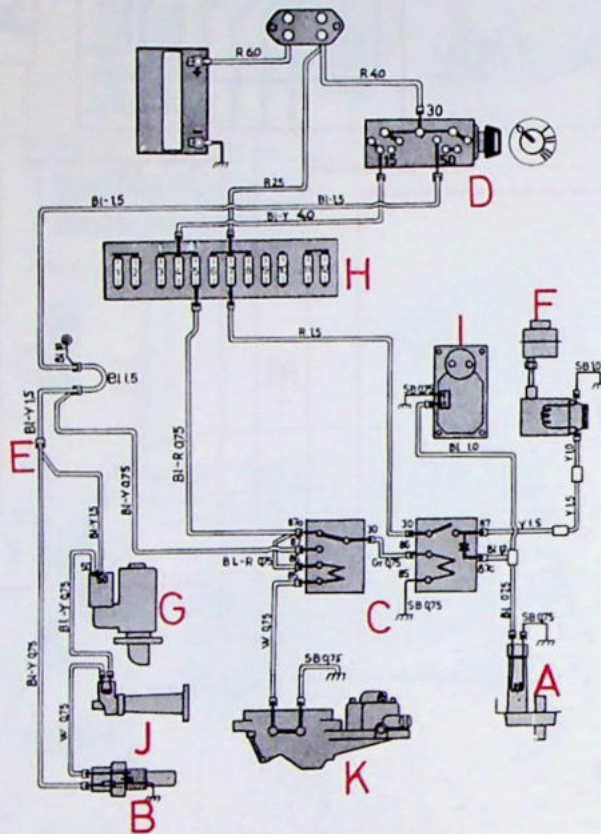

**Zekering nr 7**  
 Klokje  
 Benzinepomp, injectie

**Starten van de motor**

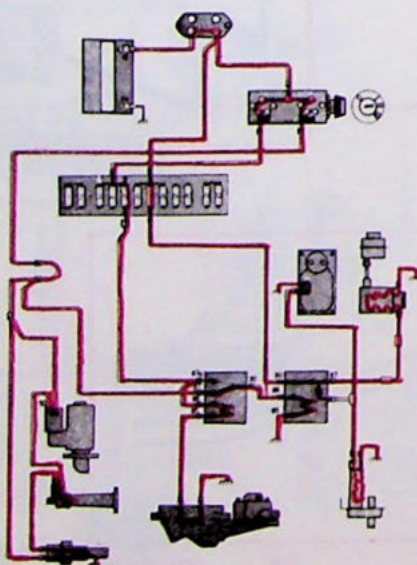

**Motor loopt**

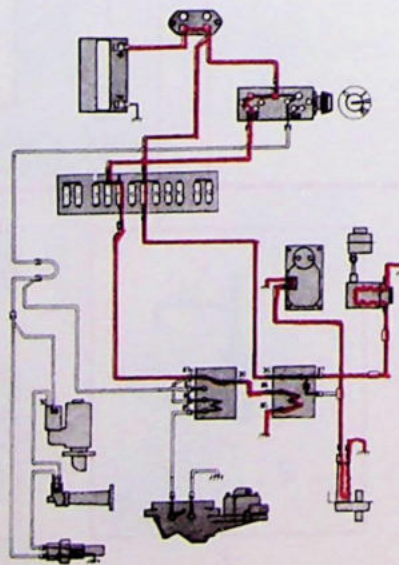

**Motor afgeslagen (ontsteking ingeschakeld, maar motor loopt niet)**

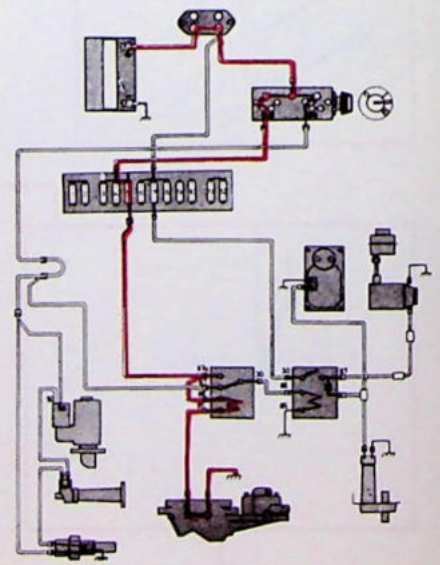

# Benzine-inspuiting -76

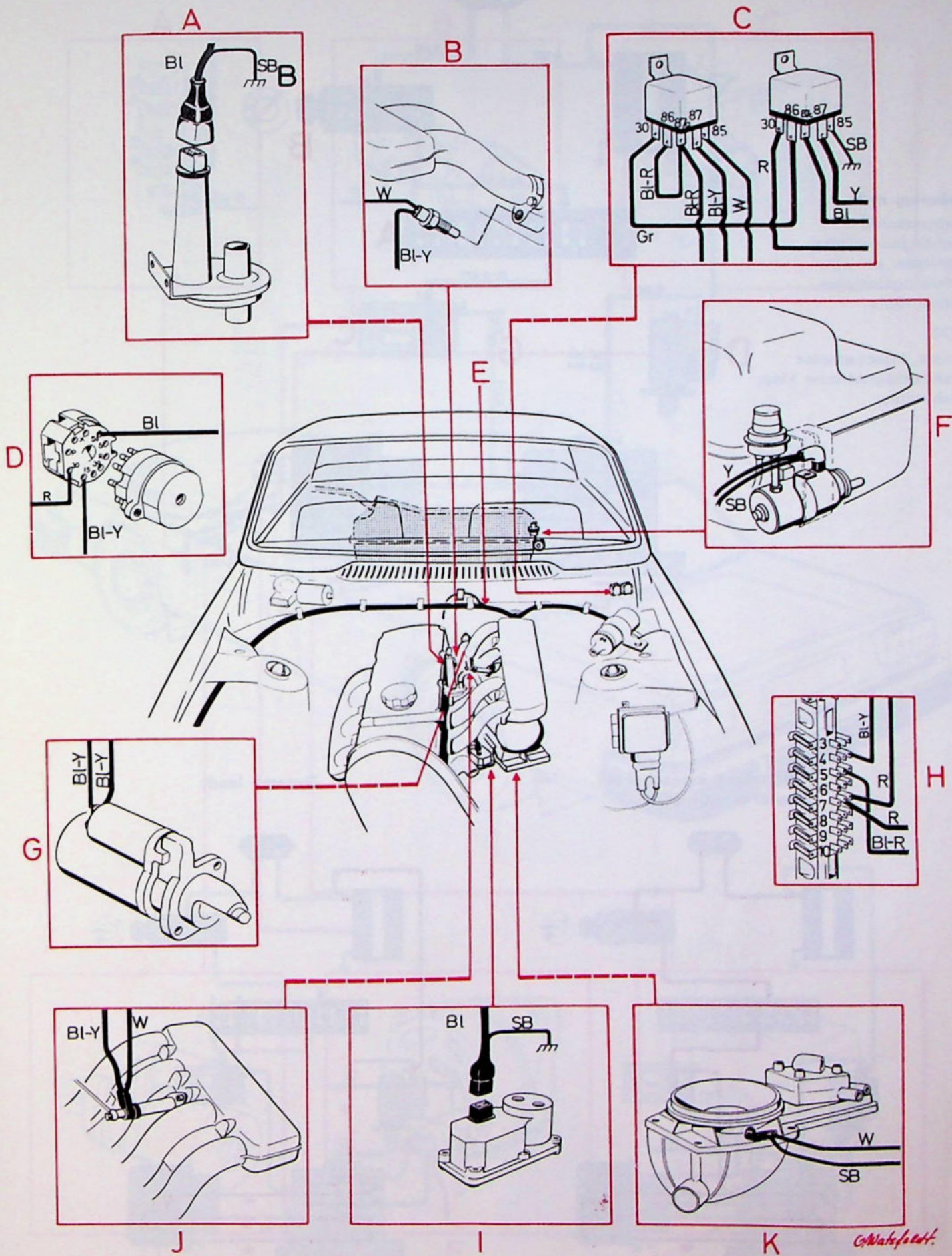

Walsdorf

# Stroomvoorziening

Zekering nr 5  
 Instrumenten  
 Richtingaanwijzers  
 Controle- en waarschuwingslampjes  
 autogordels

1976  
 Relais, injectiemotor  
 Elektromagnetische klep,  
 carburateur

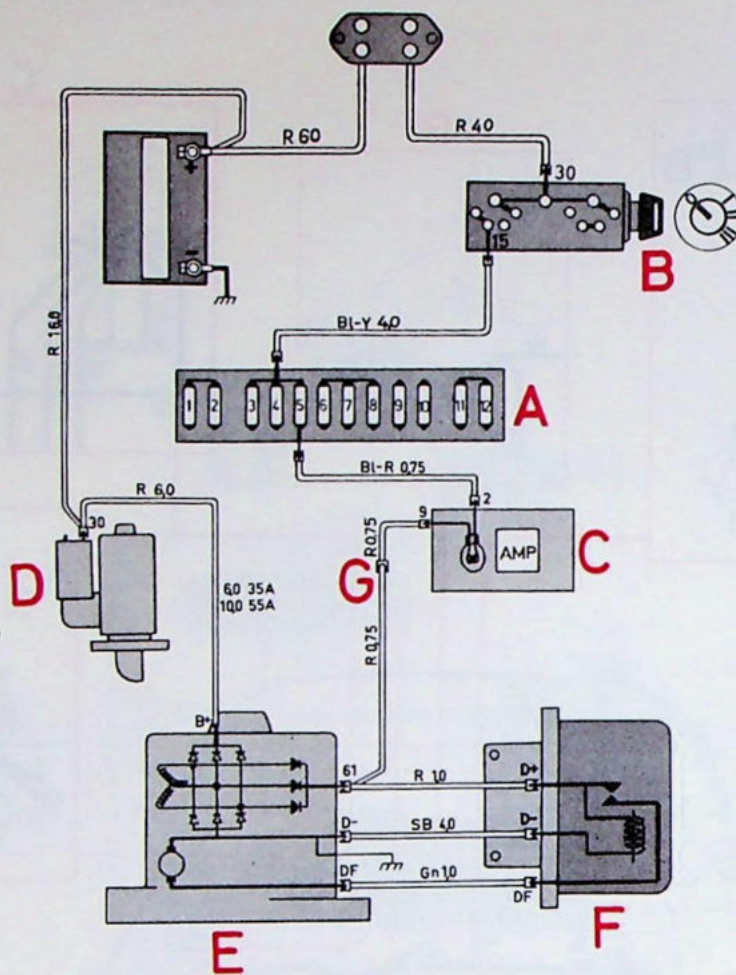

Ontsteking ingeschakeld  
 (motor loopt niet)

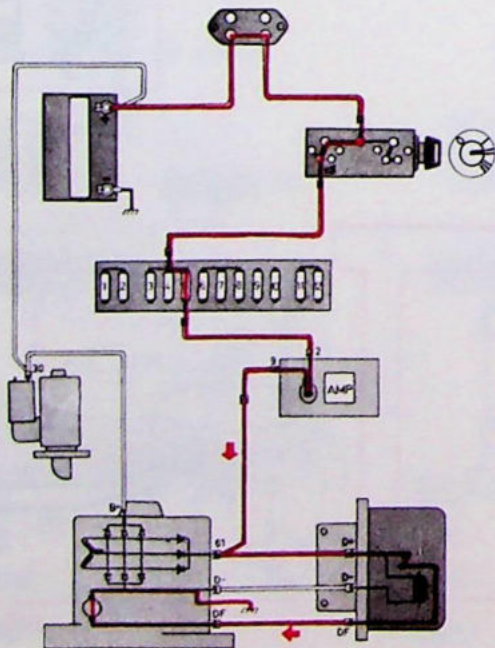

Dynamo laadt

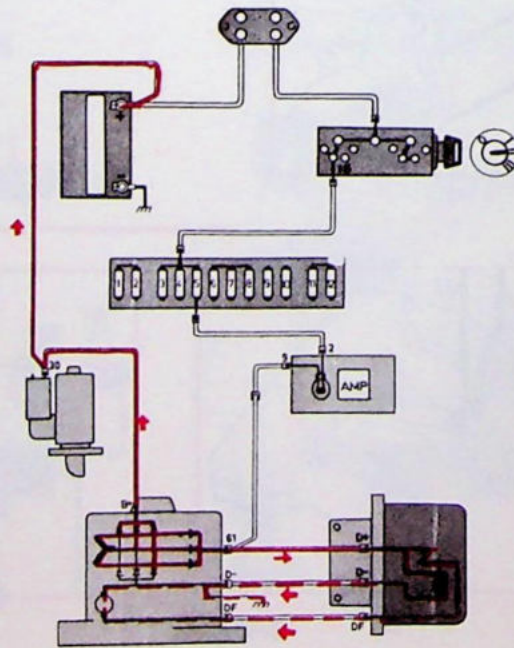

# Stroomvoorziening

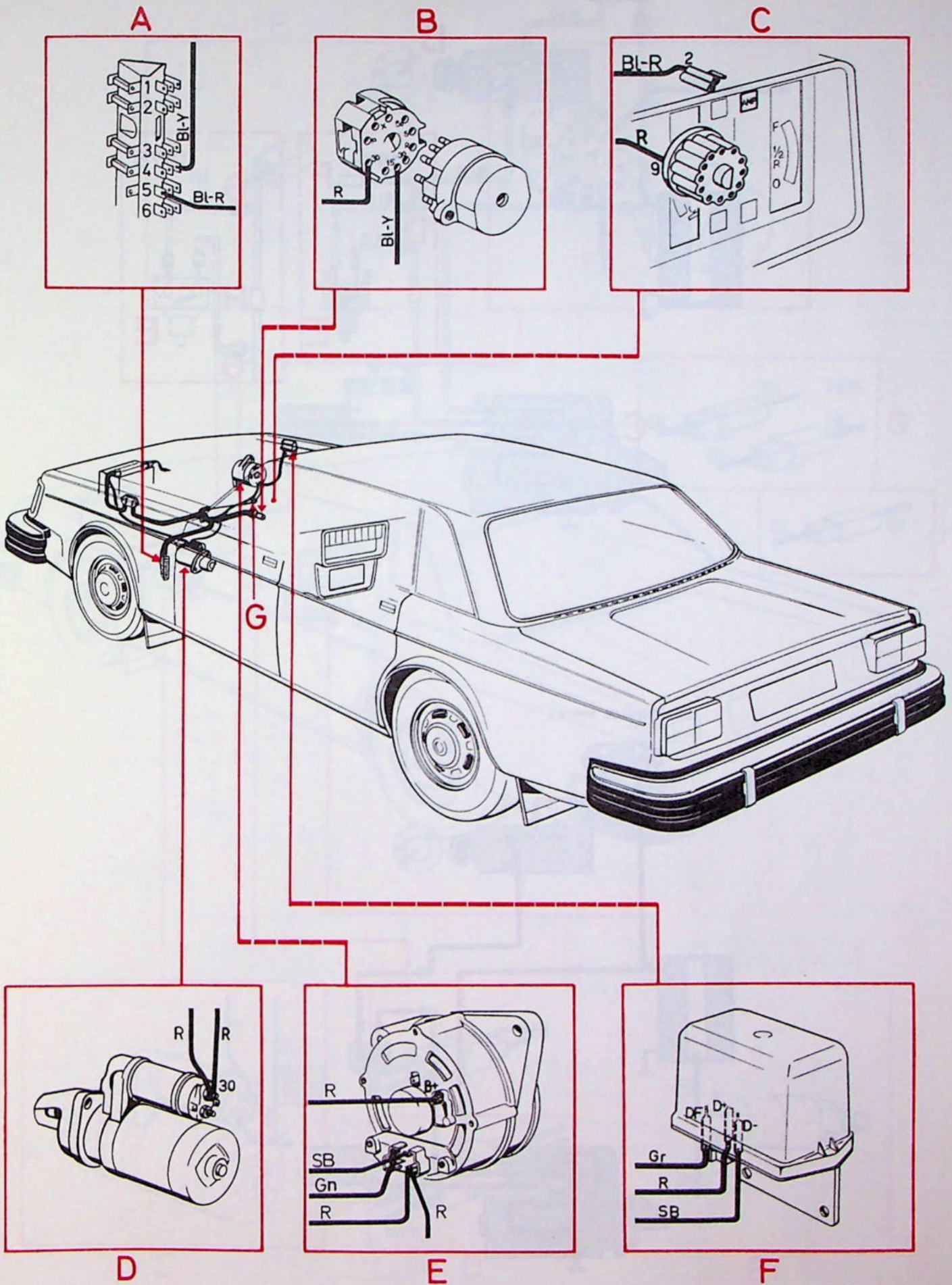

# Startsysteem

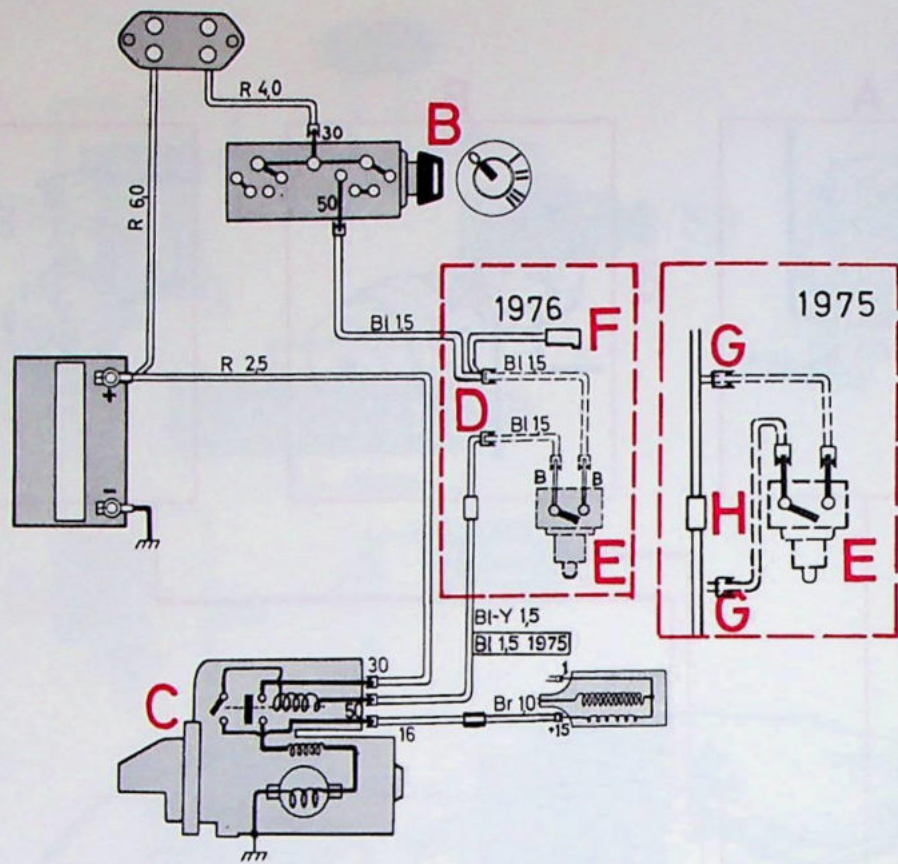

## Startmotor werkt

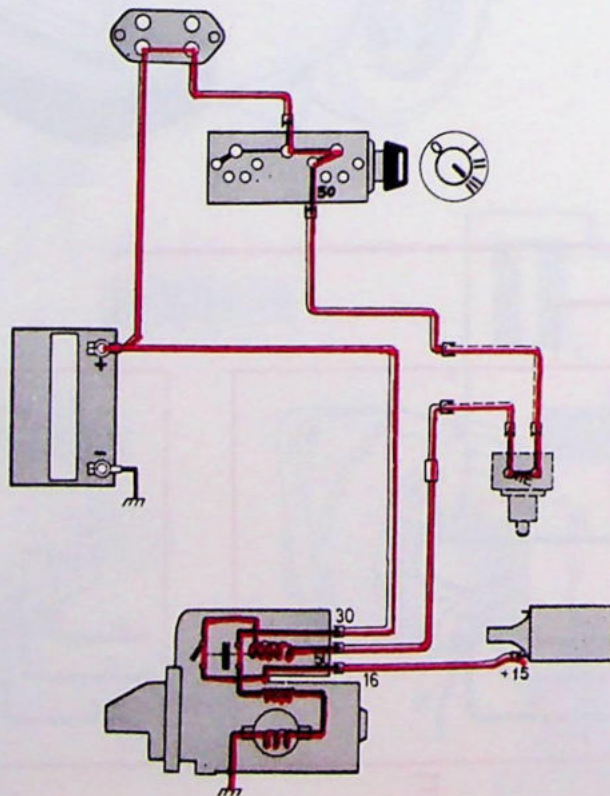

# Startsystem

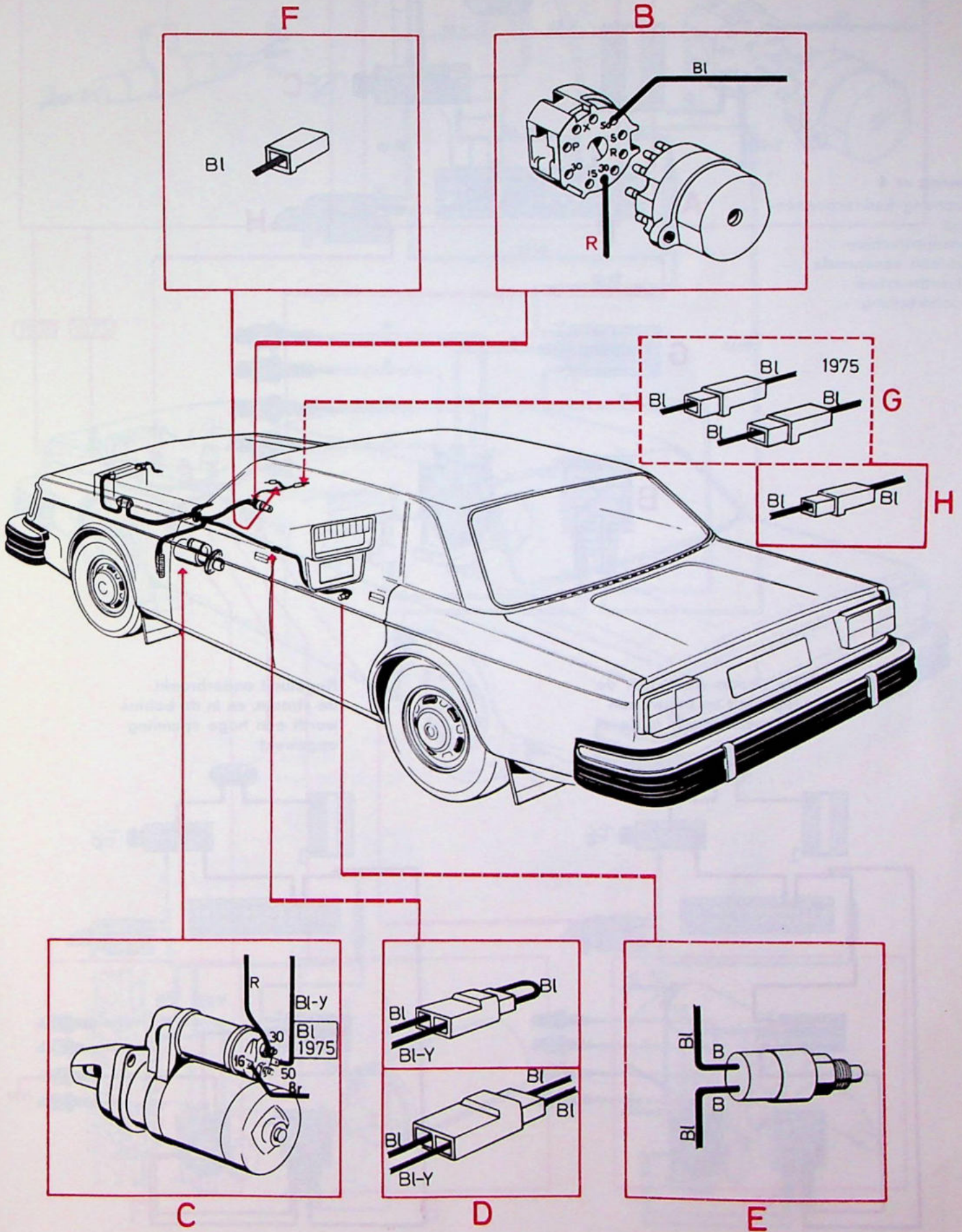

# Ontstekingsysteem zonder contactpunten

## Zekering nr 4

- Verlichting handschoenenkastje
- Achteruitrijlichten
- Elektrisch verwarmde bestuurdersstoel
- Air-conditioning

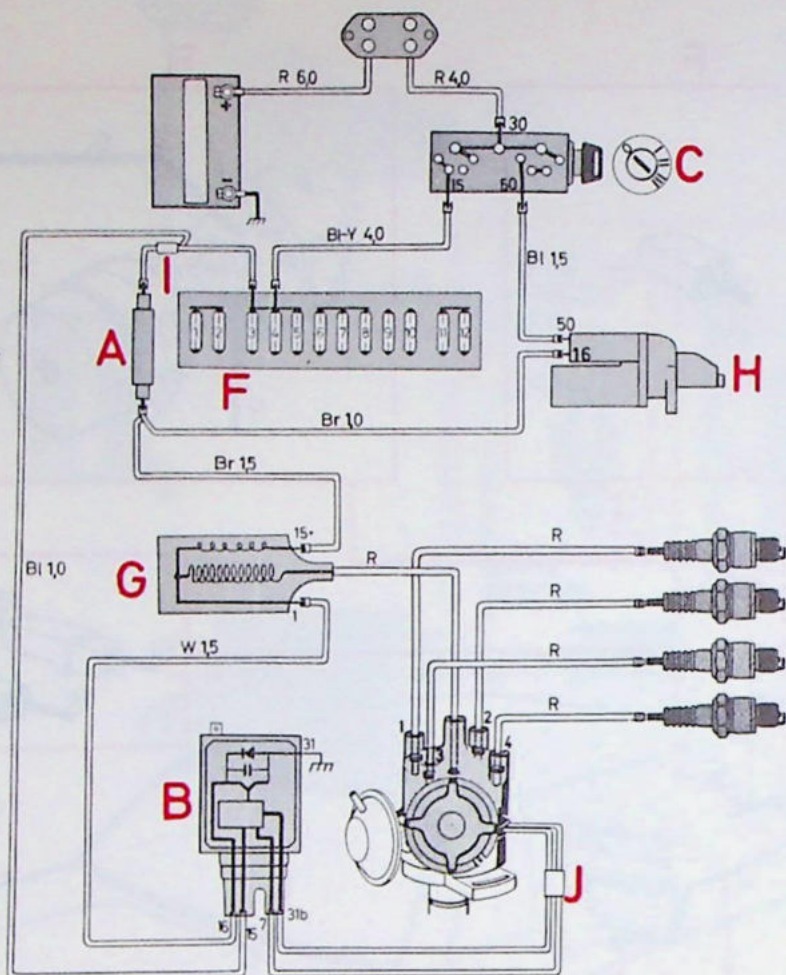

De stroom gaat door de regelunit en bouwt een magnetisch veld in de bobine op

Regelunit onderbreekt de stroom, en in de bobine wordt een hoge spanning opgewekt

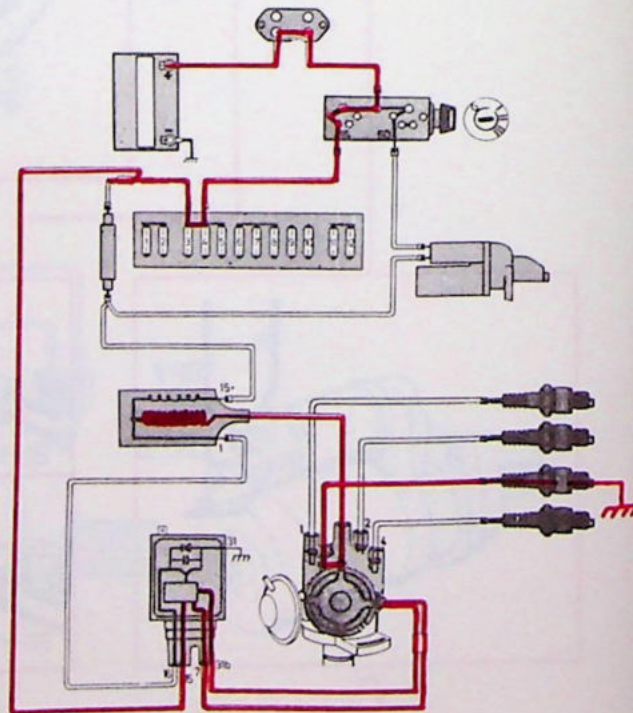
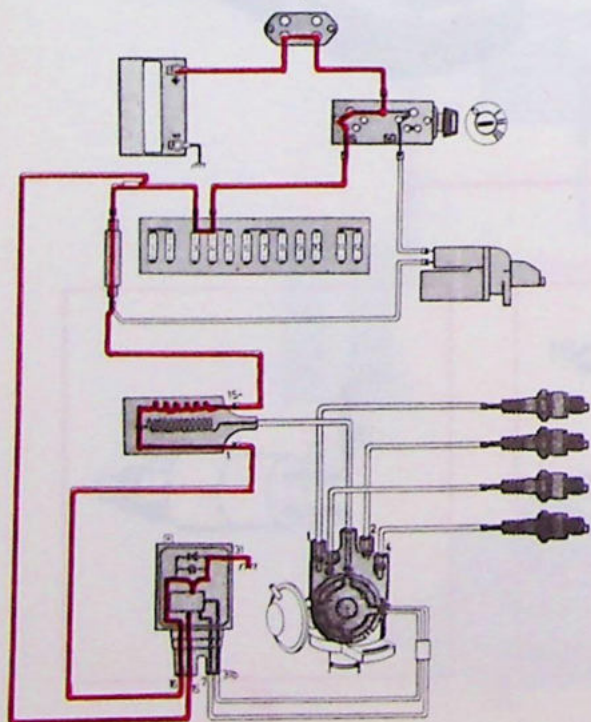

# Ontstekingsysteem zonder contactpunten

A

B

C

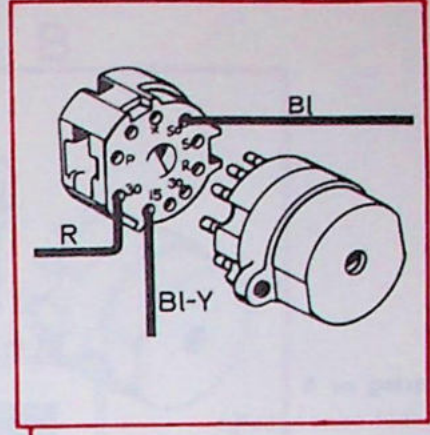
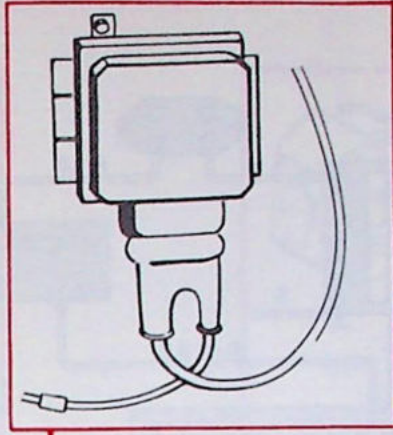
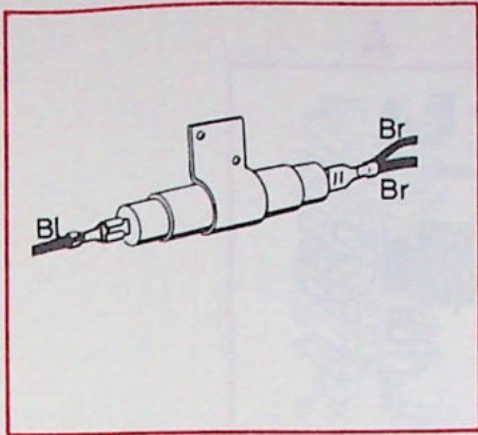

1976 1975

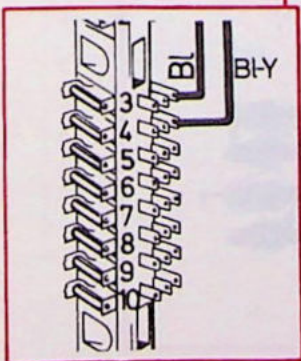
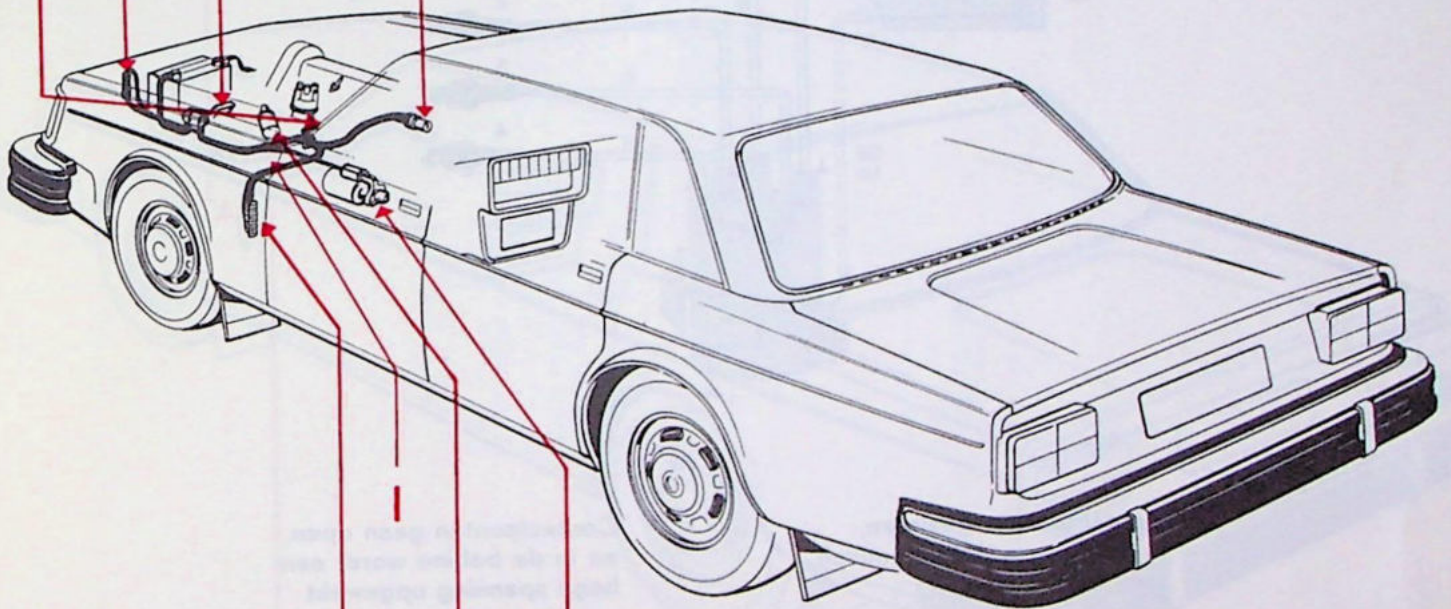

F

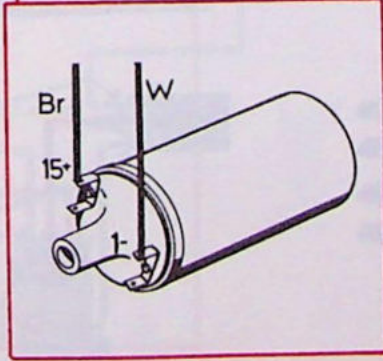

G

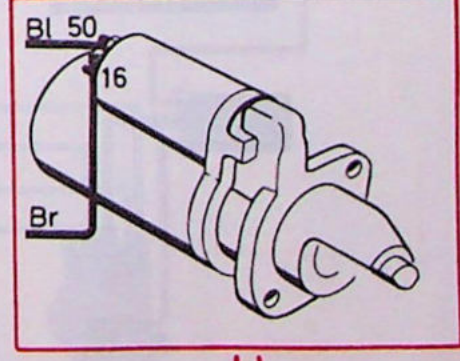

H

# Ontstekingsysteem met contactpunten

**Zekering nr 4**  
 Handschoenenkastje  
 Achteruitrijlichten  
 Elektrisch verwarmde  
 bestuurdersstoel  
 Air-conditioning

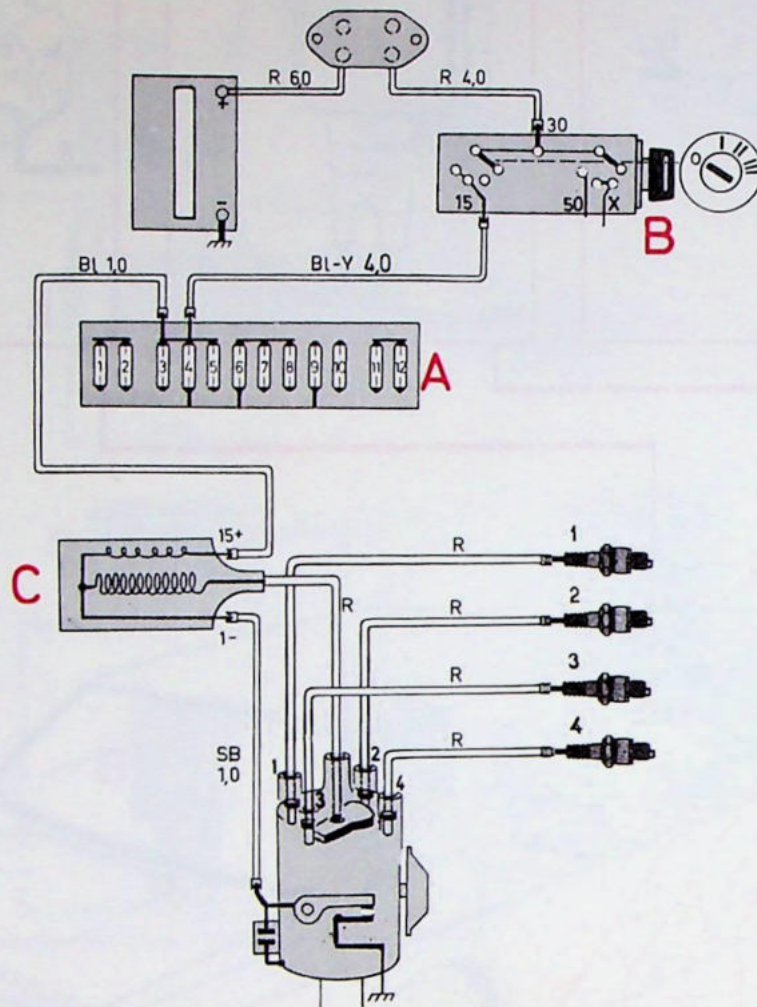

Contactpunten gesloten,  
 in bobine wordt magnetisch  
 veld opgebouwd

Contactpunten gaan open,  
 en in de bobine wordt een  
 hoge spanning opgewekt

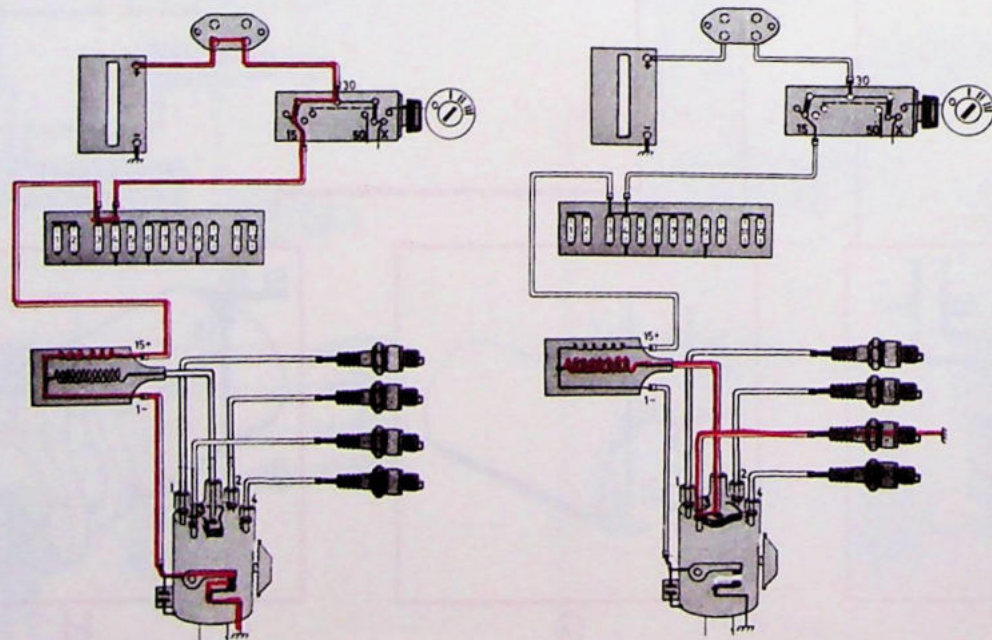



# Groot- en dimlicht

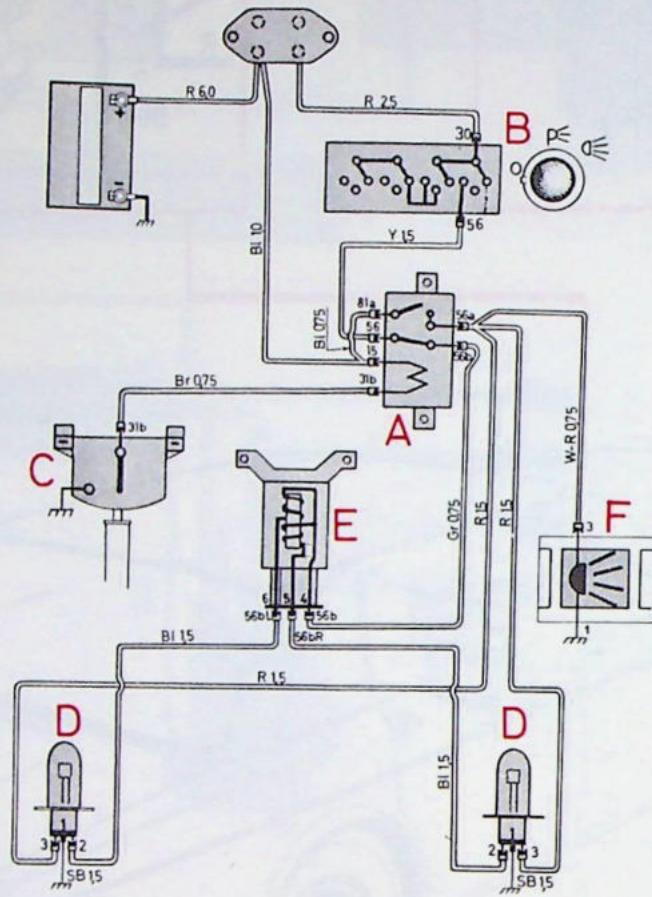

Groot licht

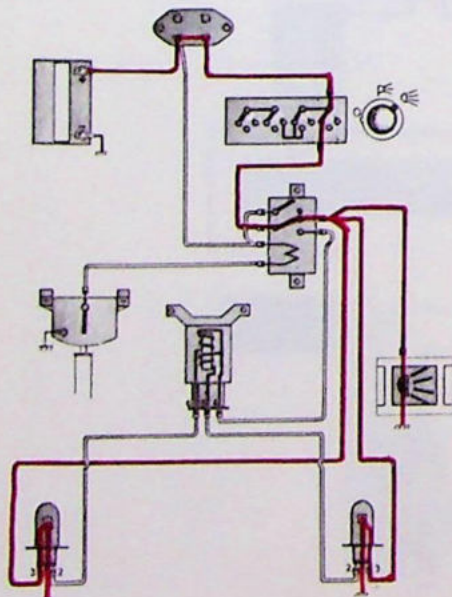

Dimlicht

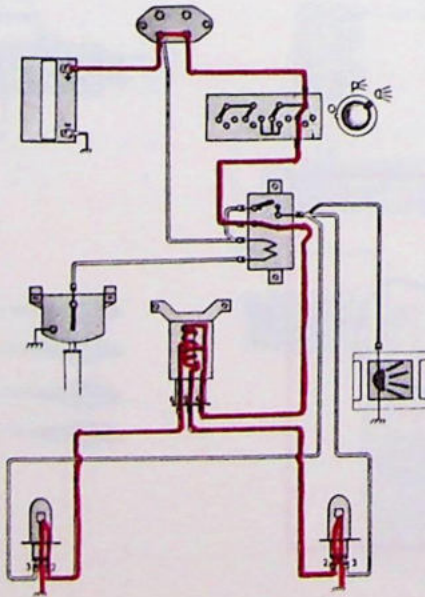

Grootlichtsignaal

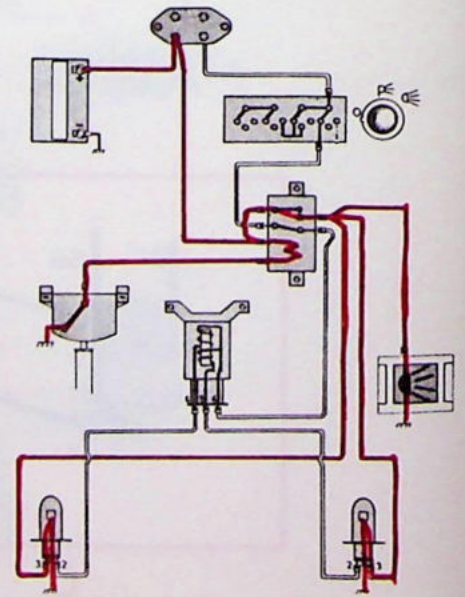

# Groot- en dimlicht

A

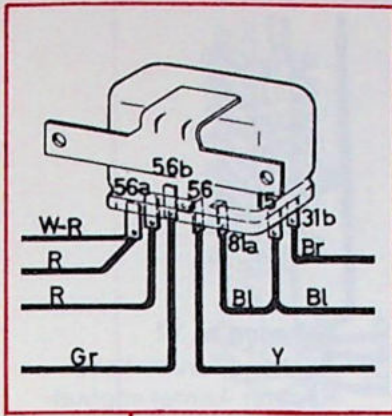

B

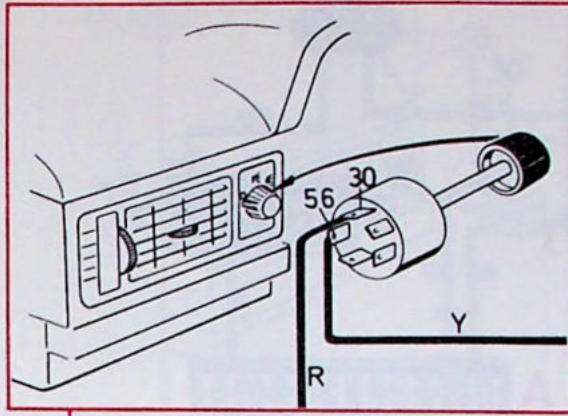

C

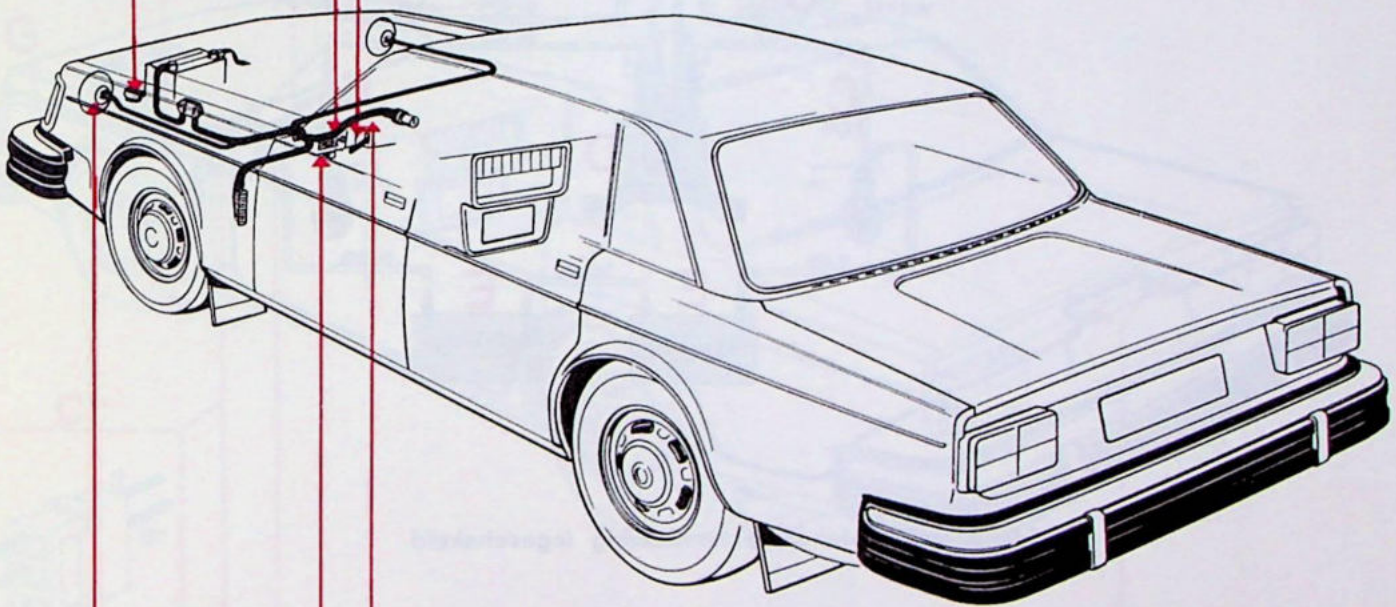
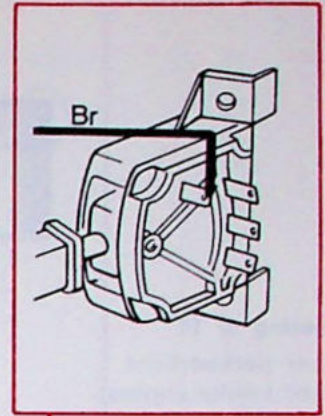

D

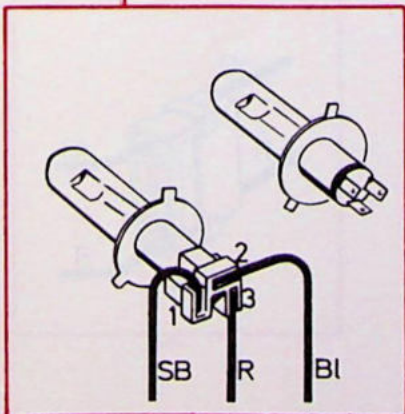

E

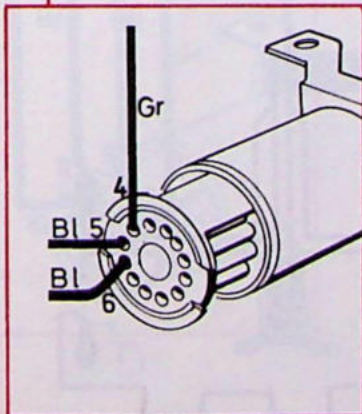

F

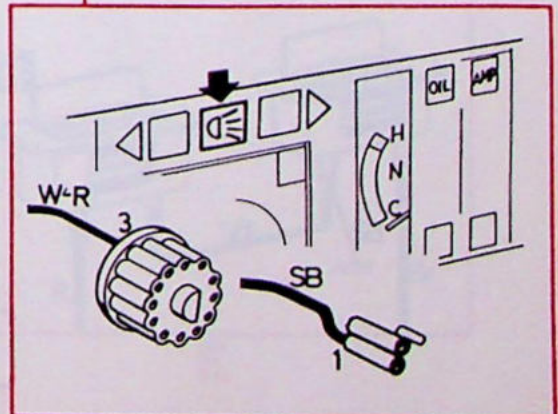

# Stads- en kentekenplaatverlichting 242/244

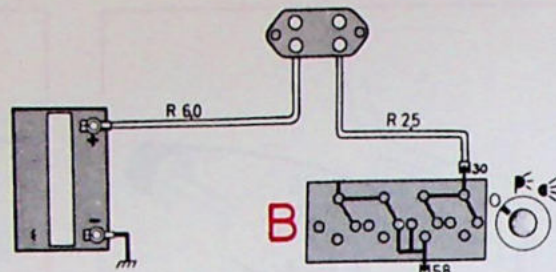

**Zekering nr 11**  
 Linker parkeerlicht  
 Linker kentekenplaat-  
 verlichting  
 (245: links en rechts)

**Zekering nr 12**  
 Rechter parkeerlicht  
 Rechter kentekenplaat-  
 verlichting  
 Instrumenten- en paneel-  
 verlichting

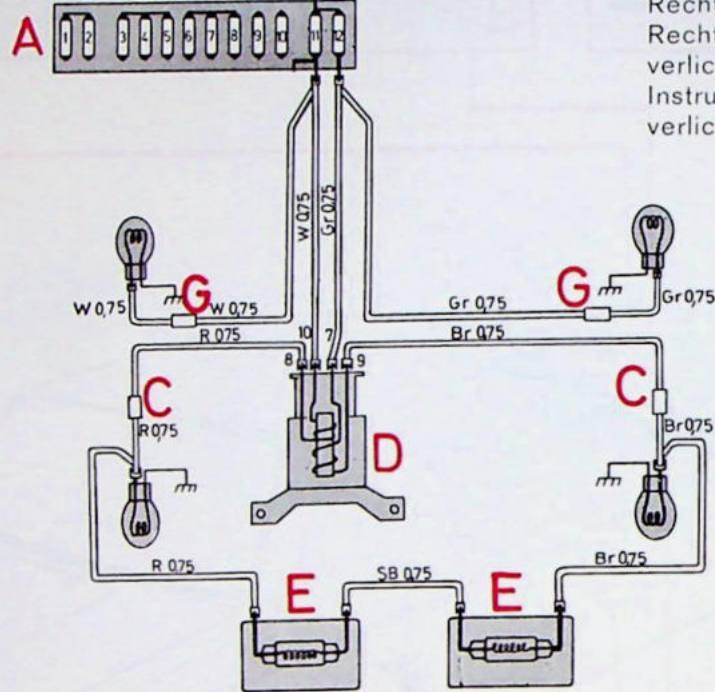

Stads- en kentekenplaatverlichting ingeschakeld

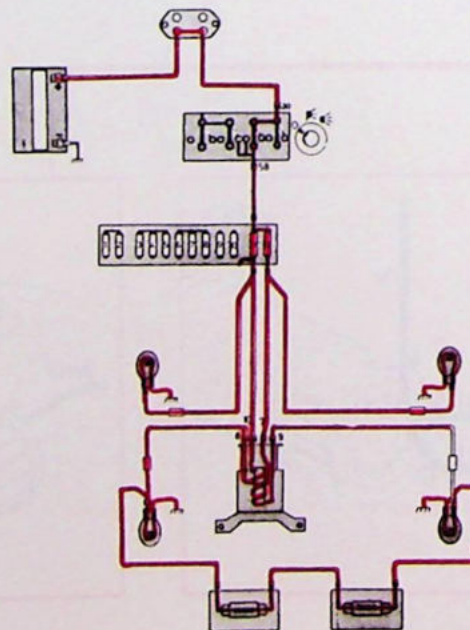

# Stads- en kentekenplaatverlichting 242/244

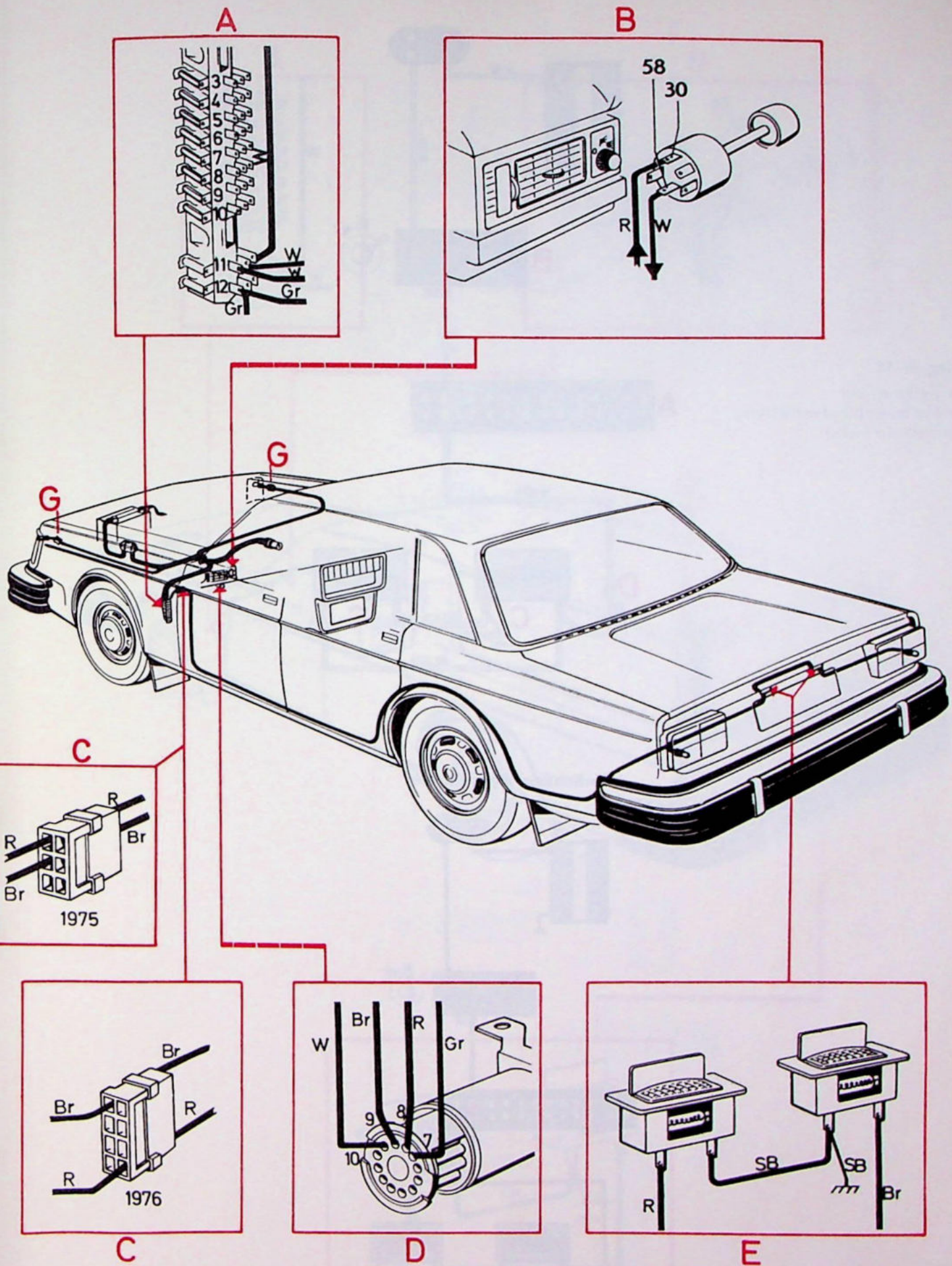

# Kentekenplaatverlichting 245

Zekering nr 11  
 Linker parkeerlicht  
 Linker kentekenplaatverlichting  
 (245: rechts en links)

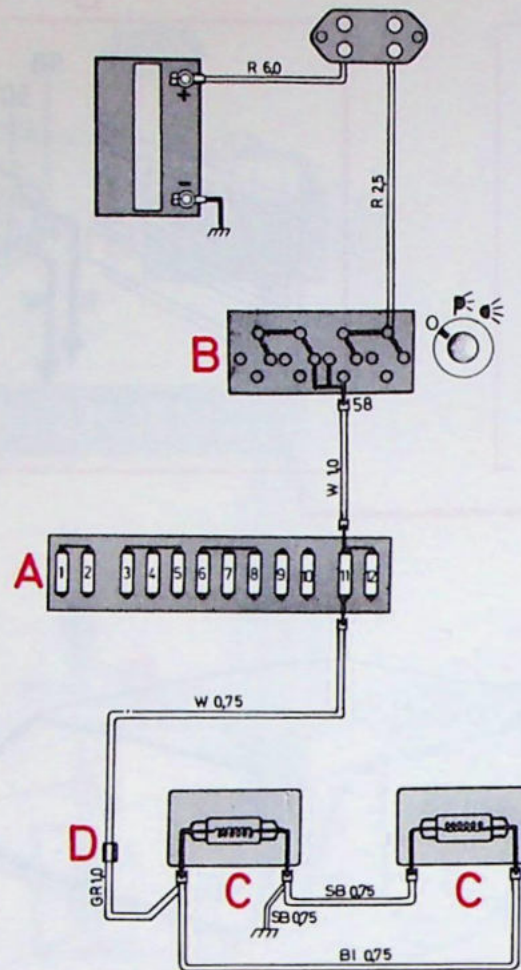

Verlichting ingeschakeld

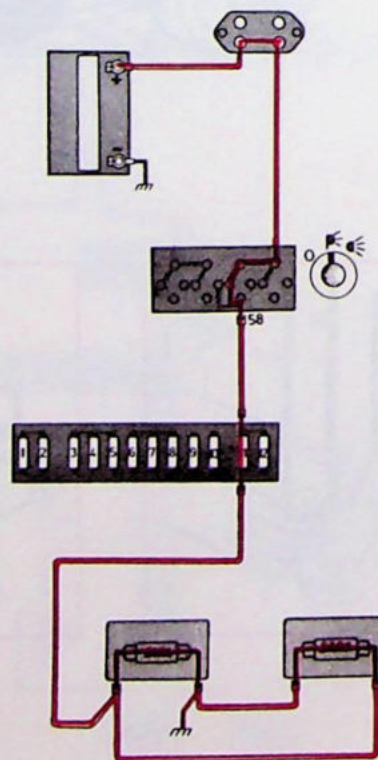

# Kentekenplaatverlichting 245

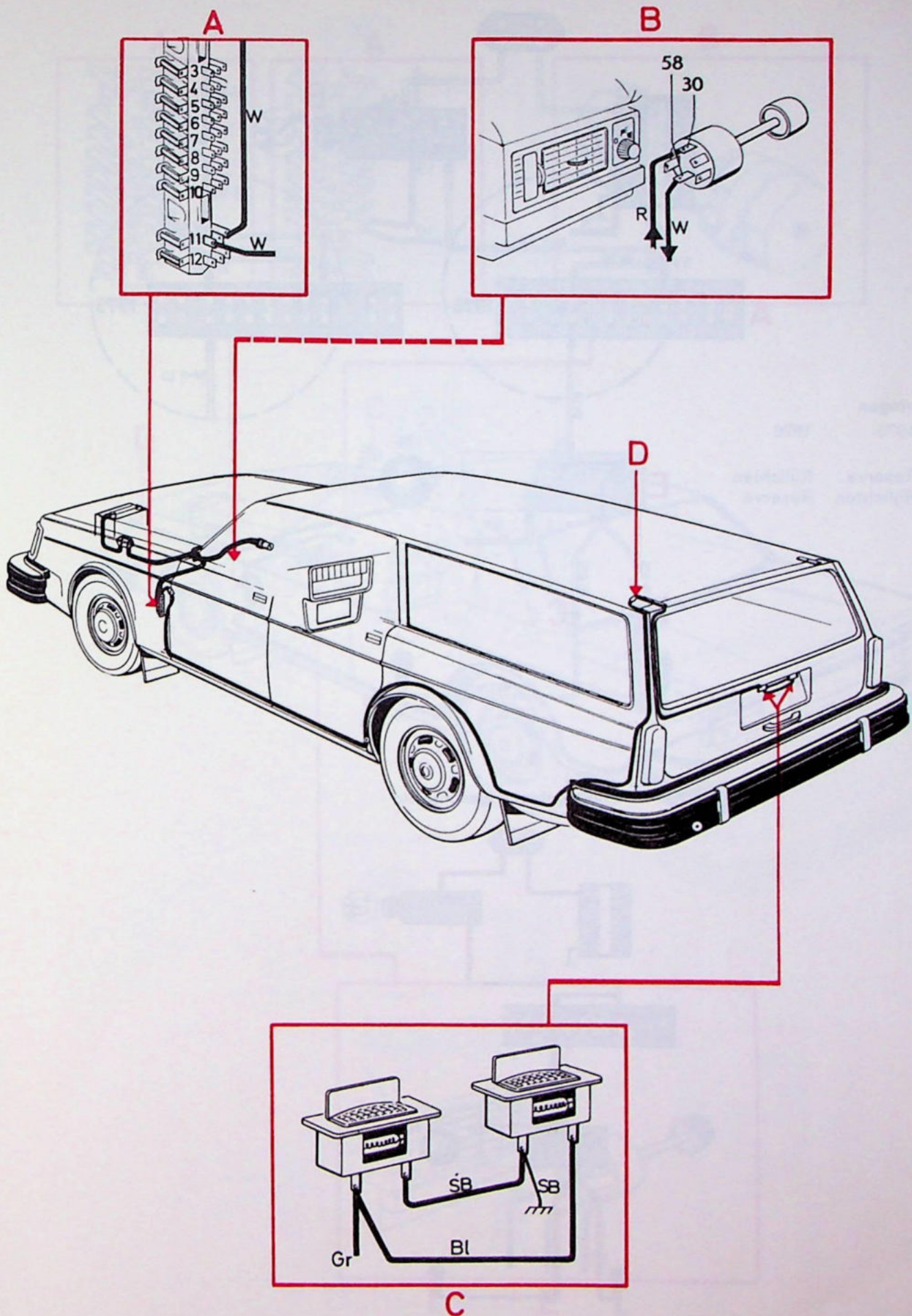

# Rijlichten

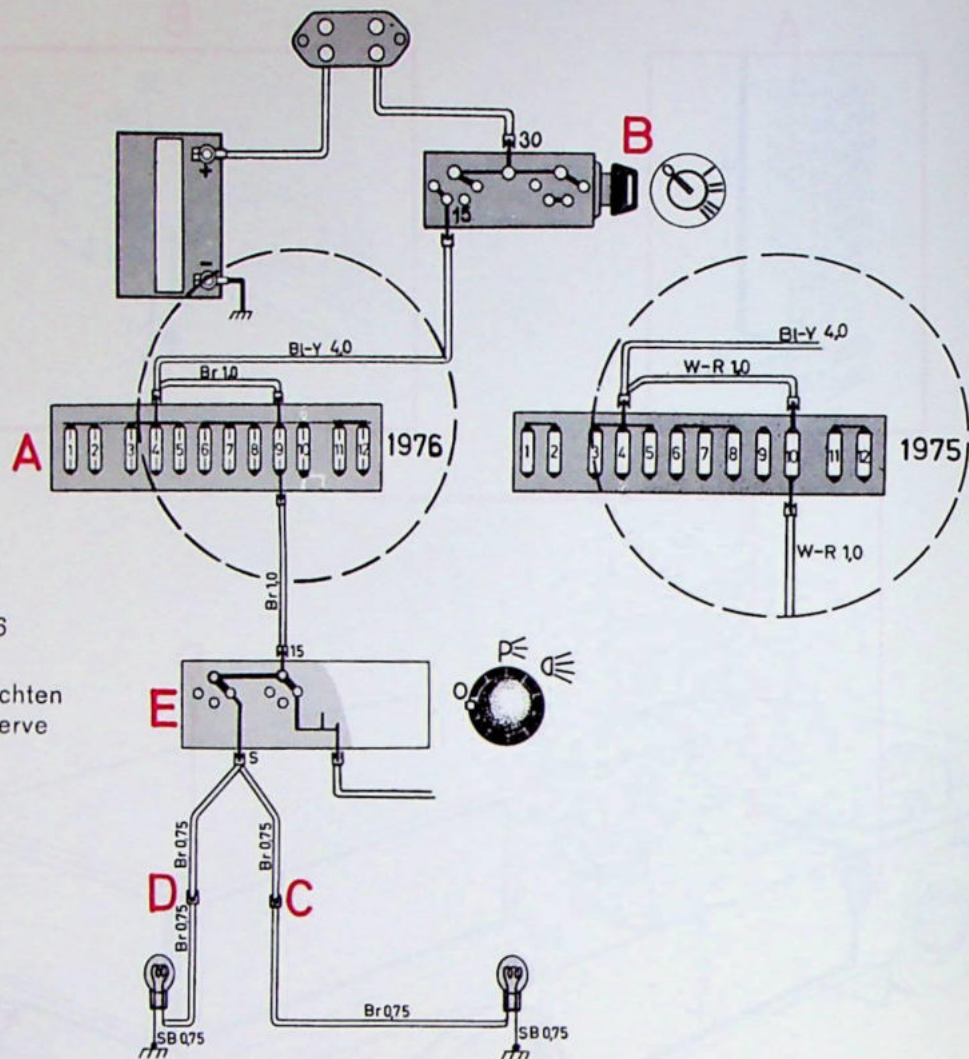

## Zekeringen

	1975	1976
Nr		
9	Reserve	Rijlichten
10	Rijlichten	Reserve

## Het contact ingeschakeld

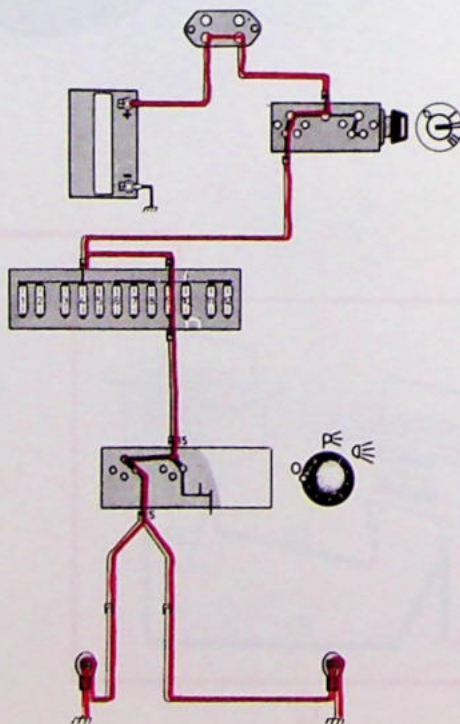

# Rijlichten

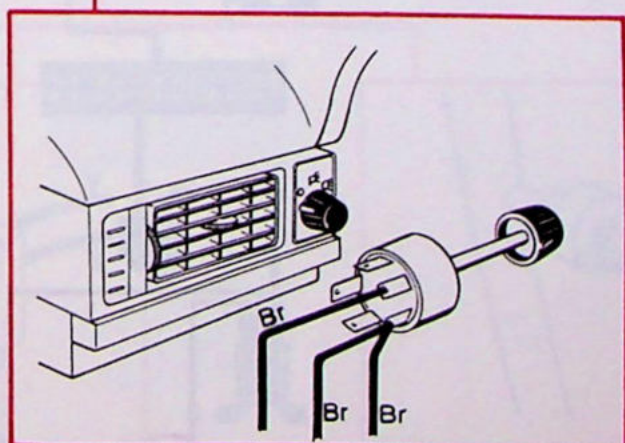
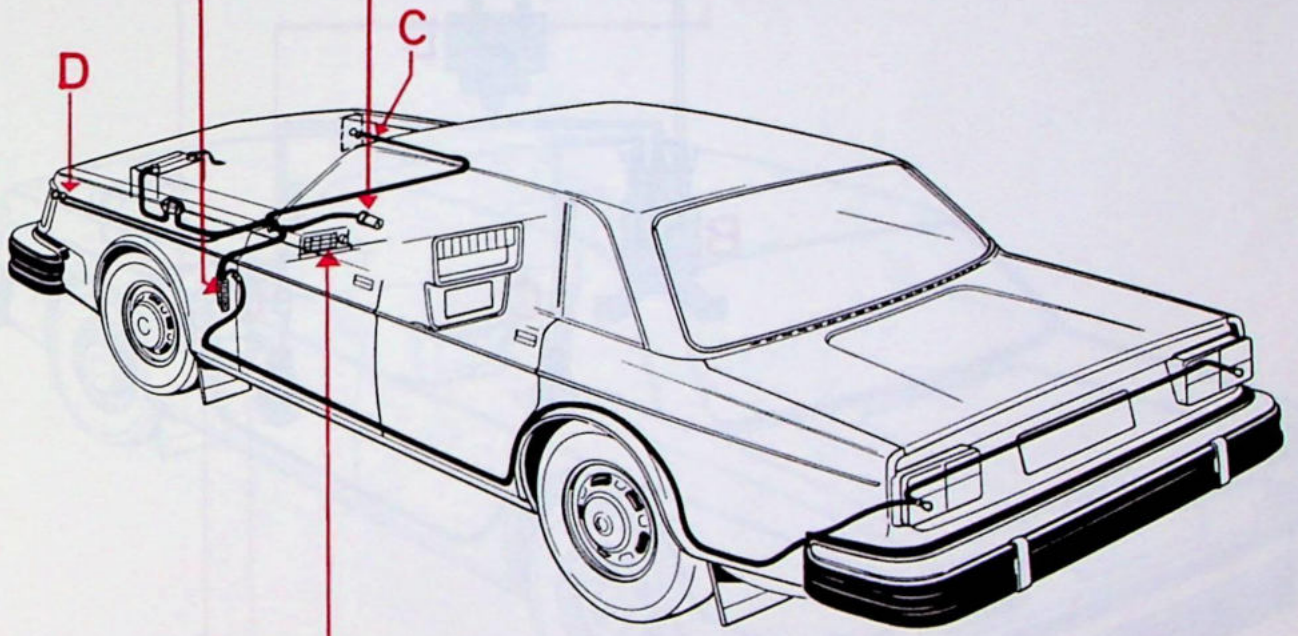
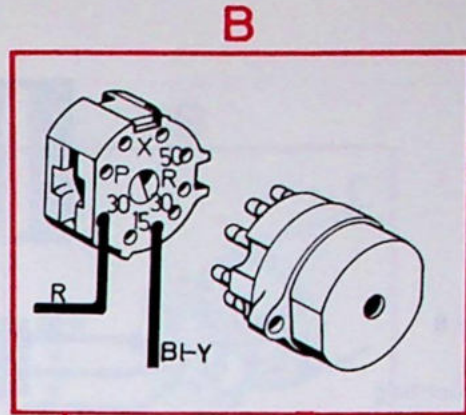
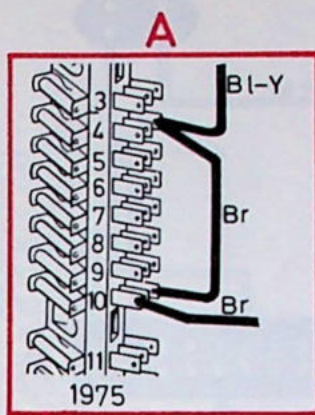
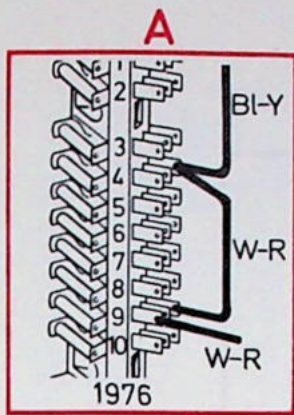

# Stoplichten

Zekering nr 8  
Remlichten  
Interieurverlichting

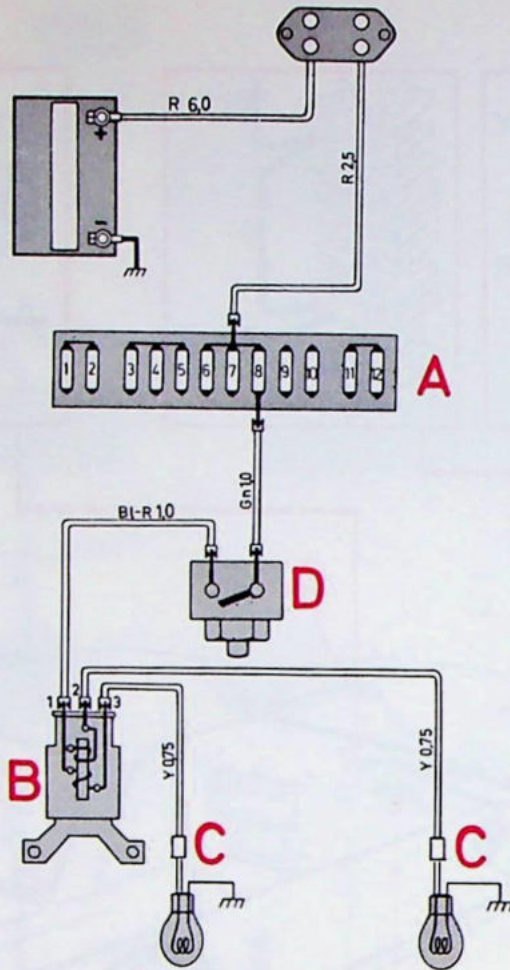

Rempedaal ingedrukt

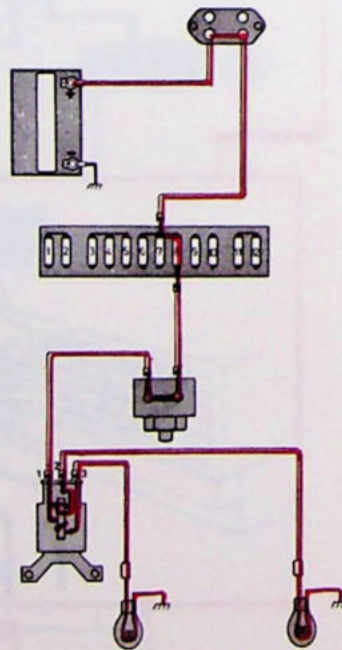

# Stoplichter

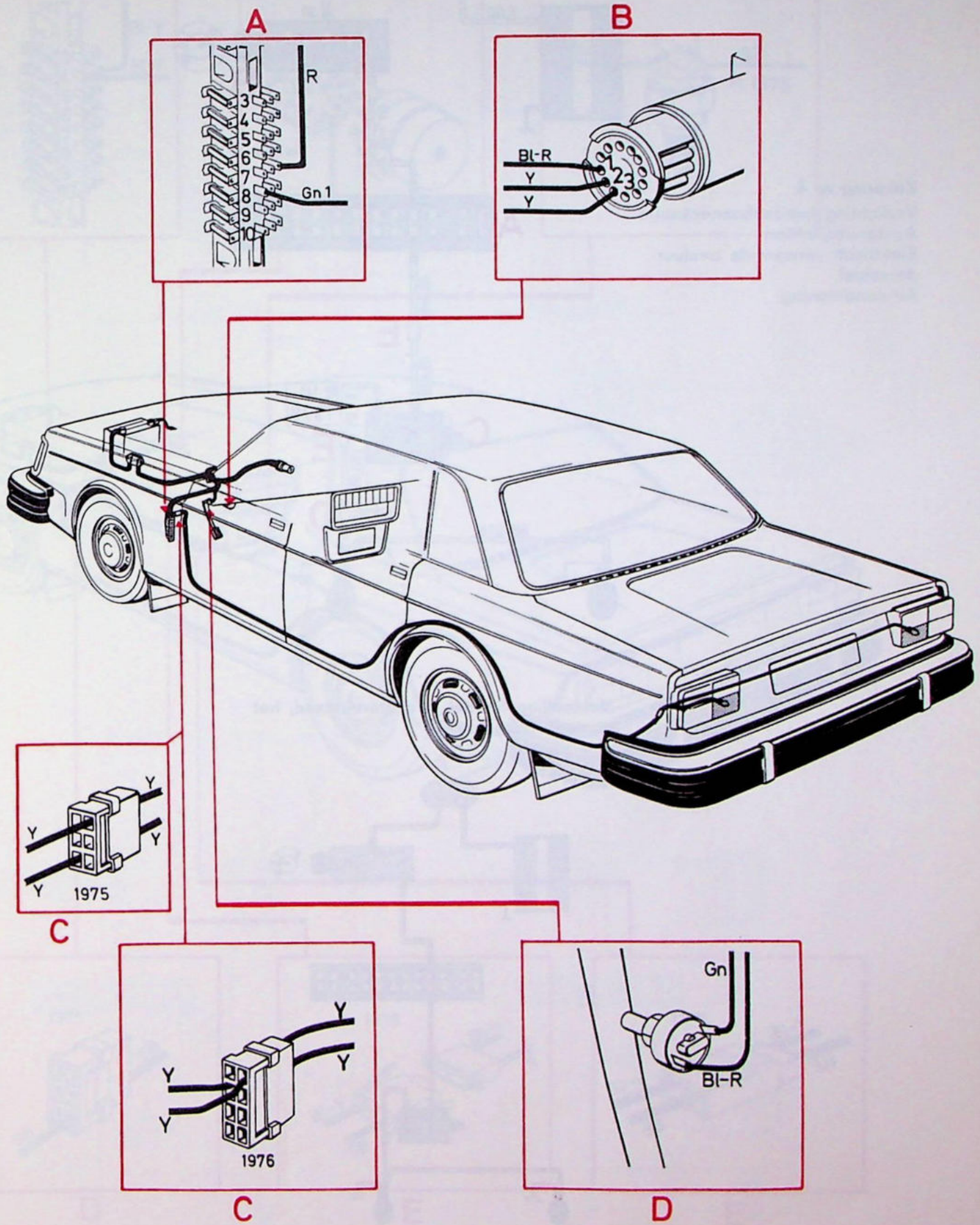

# Achteruitrijlichten, handgeschakelde versnellingsbak

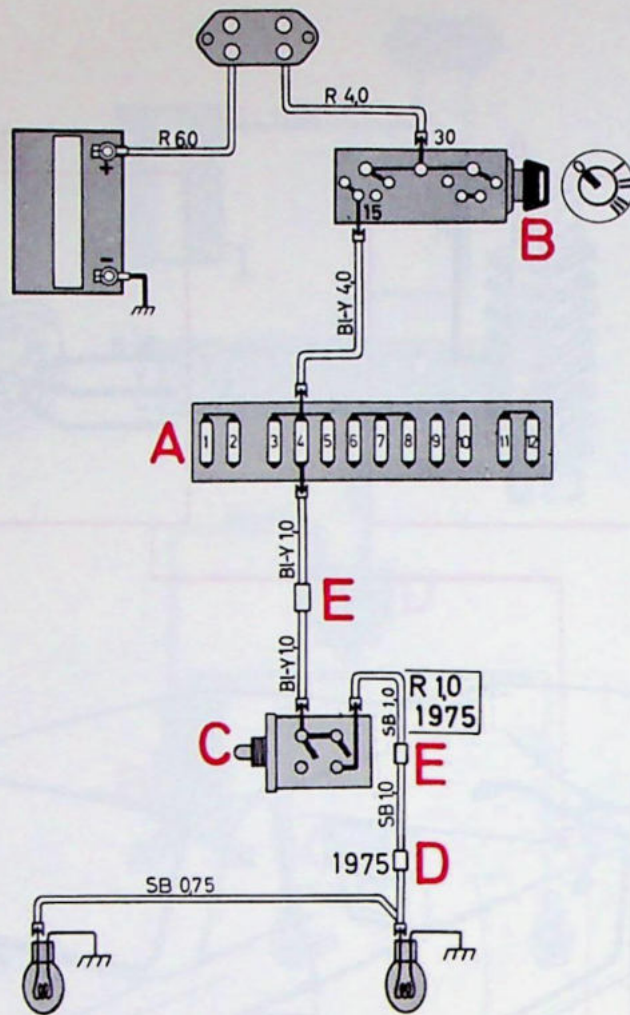

## Zekering nr 4

- Verlichting handschoenenkastje
- Achteruitrijlichten
- Elektrisch verwarmde bestuurdersstoel
- Air-conditioning

Versnellingshendel in achteruitstand, het contact ingeschakeld

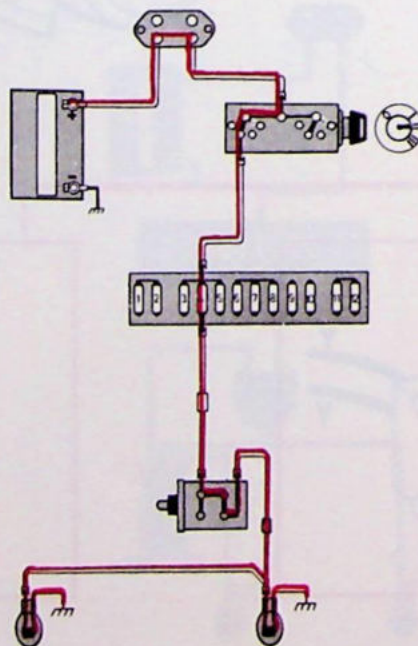

# Achteruitrijlichten, handgeschakelde versnellingsbak

A

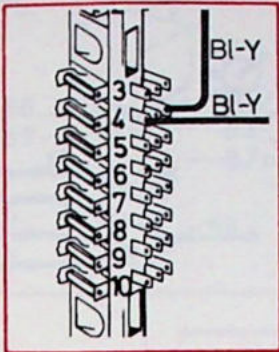

B

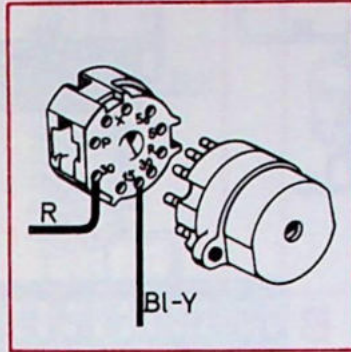

C

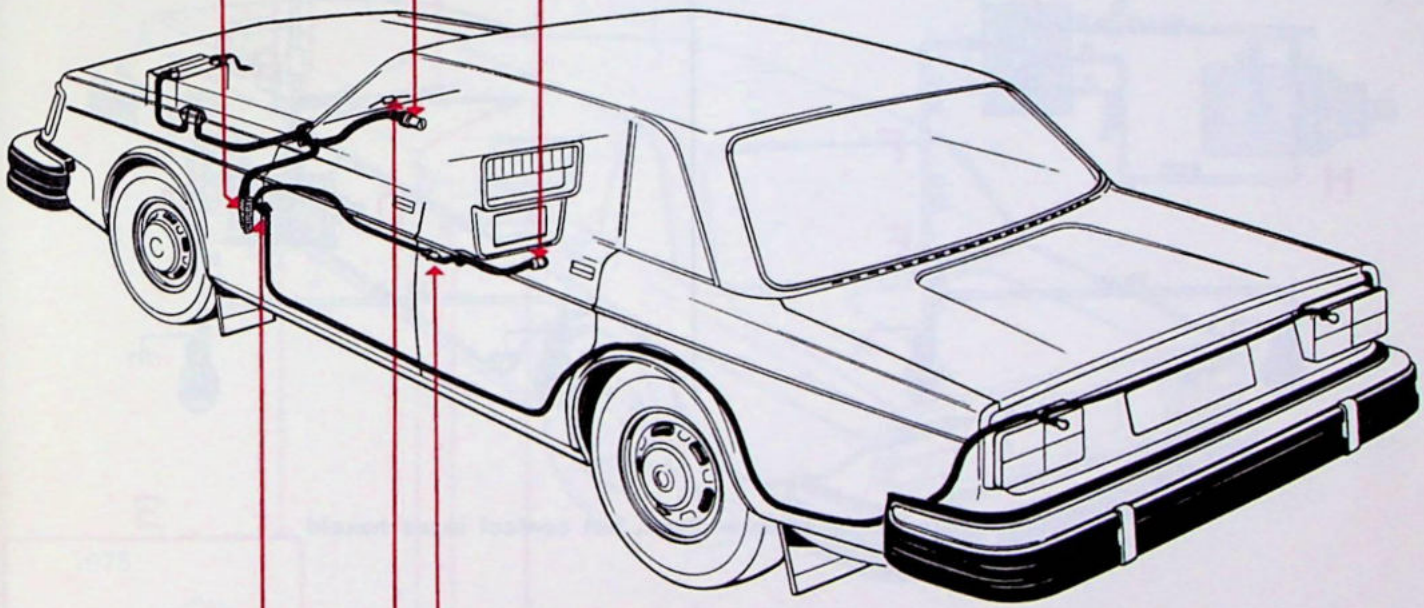
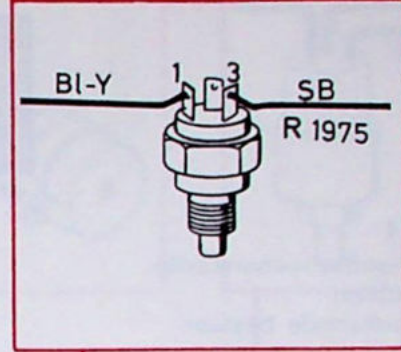

1975

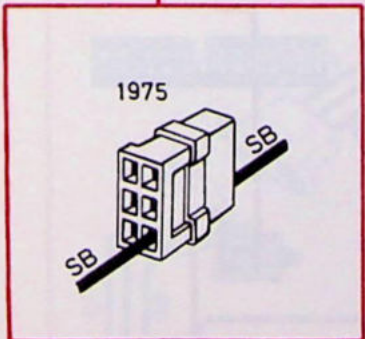

D

1975

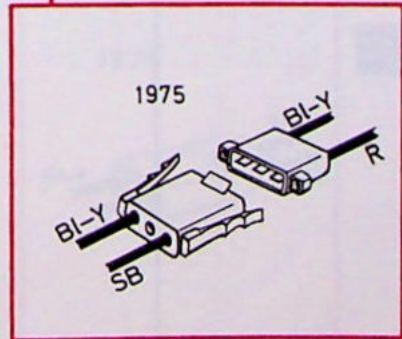

E

1976

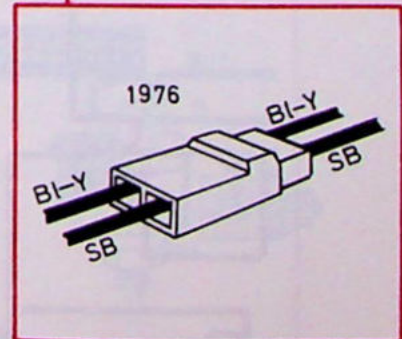

E

# Achteruitrijlichten, automatische versnellingsbak

**Zekering nr 4**  
 Verlichting handschoenenkastje  
 Achteruitrijlichten  
 Elektrisch verwarmde bestuurdersstoel  
 Air-conditioning

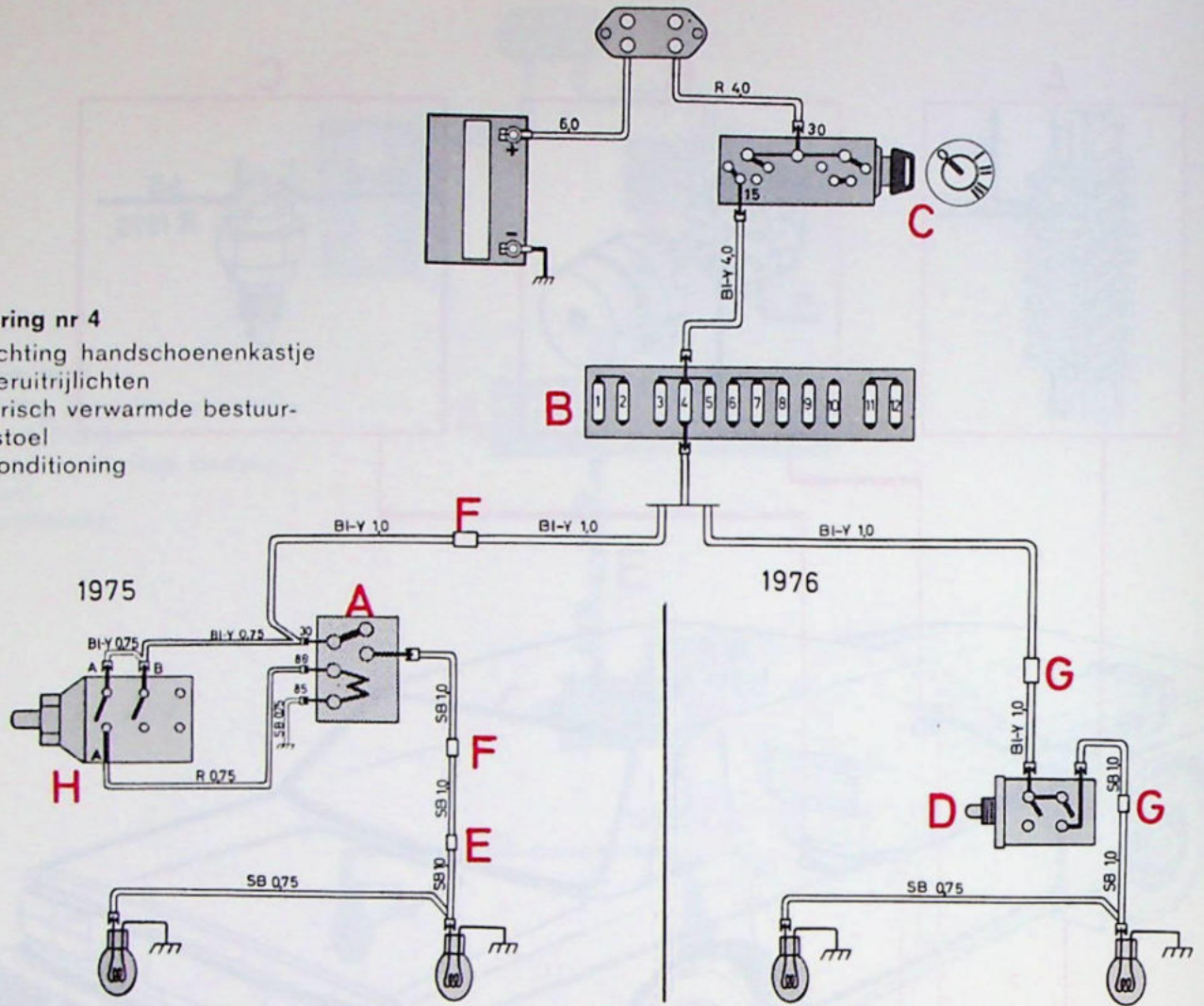

Keuzehendel in achteruitstand, het contact ingeschakeld

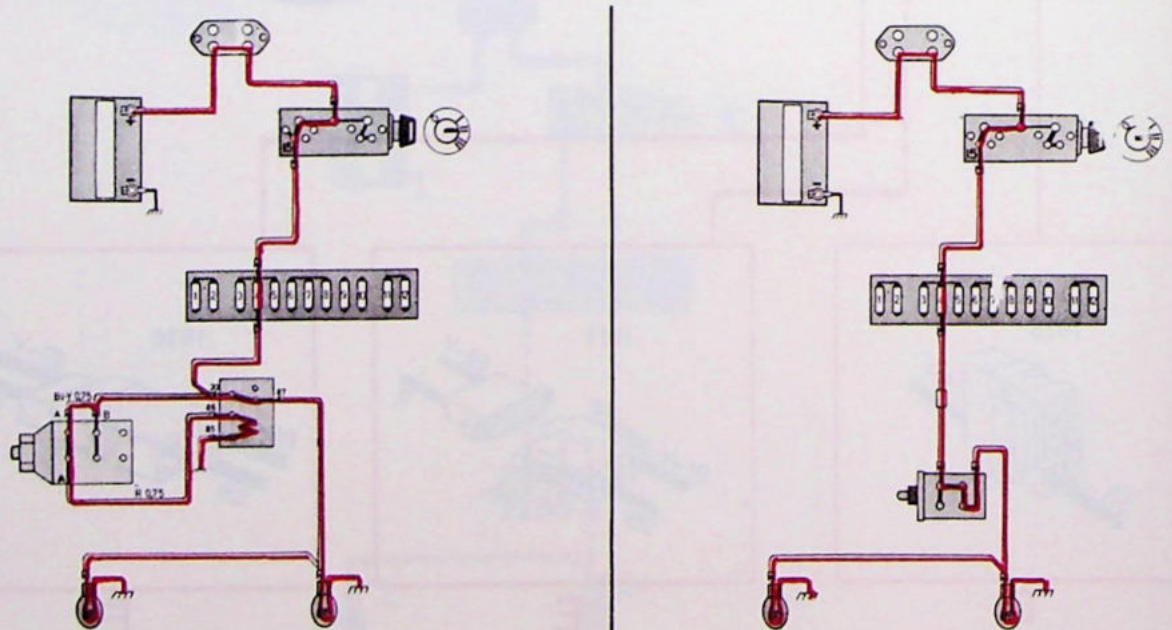

# Achteruitrijlichten, automatische versnellingsbak

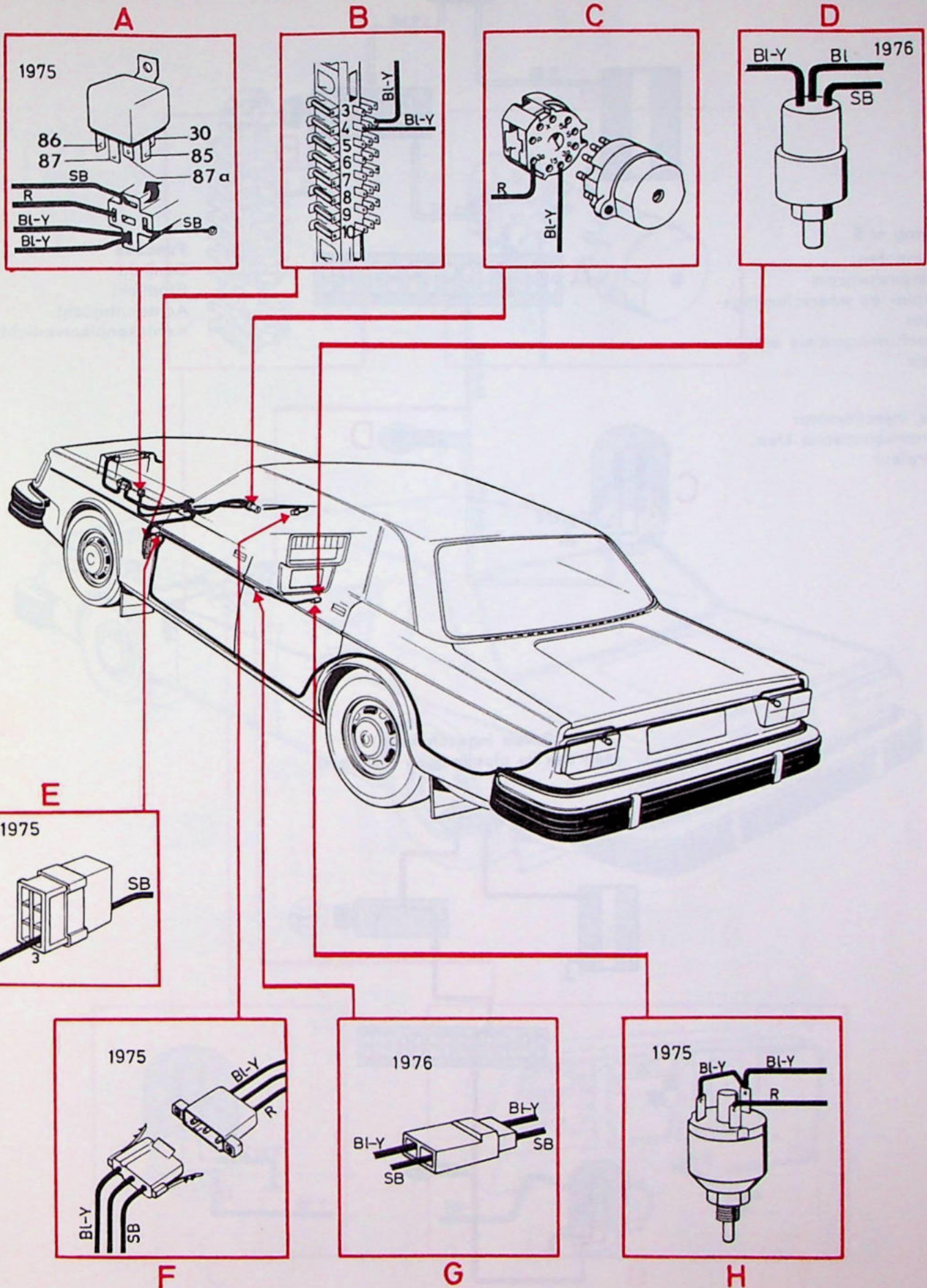

# Relais voor waarschuingslampje defecte gloeilampen

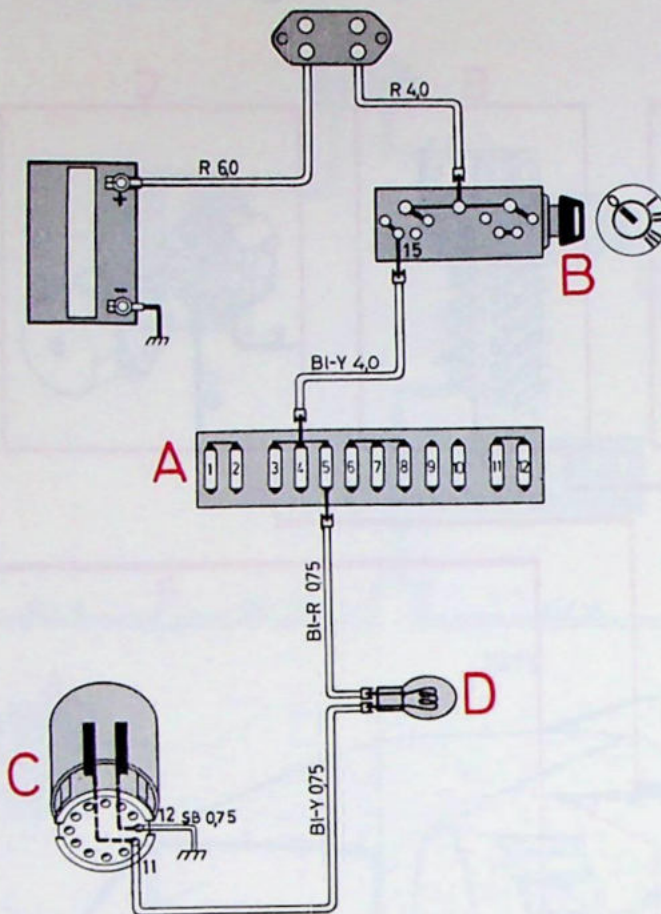

## Zekering nr 5

Instrumenten  
 Richtingaanwijzers  
 Controle- en waarschuings-  
 lampjes  
 Waarschuingsrelais auto-  
 gordels

1976

Relais, injectiemotor  
 Elektromagnetische klep,  
 carburateur

## Functies

Dimlicht  
 Stoplicht  
 Achteruitrijlicht  
 Kentekenplaatverlichting

Relais ingeschakeld  
 (één van de gloeilampen is defect)

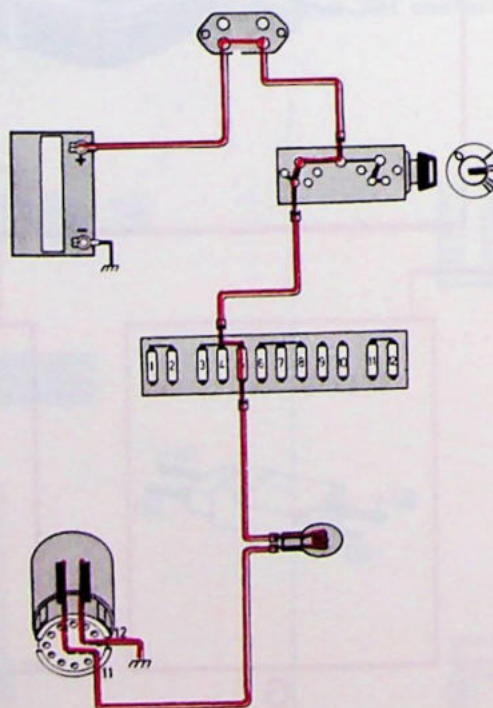

# Relais voor waarschuwingslampje defecte gloeilampen

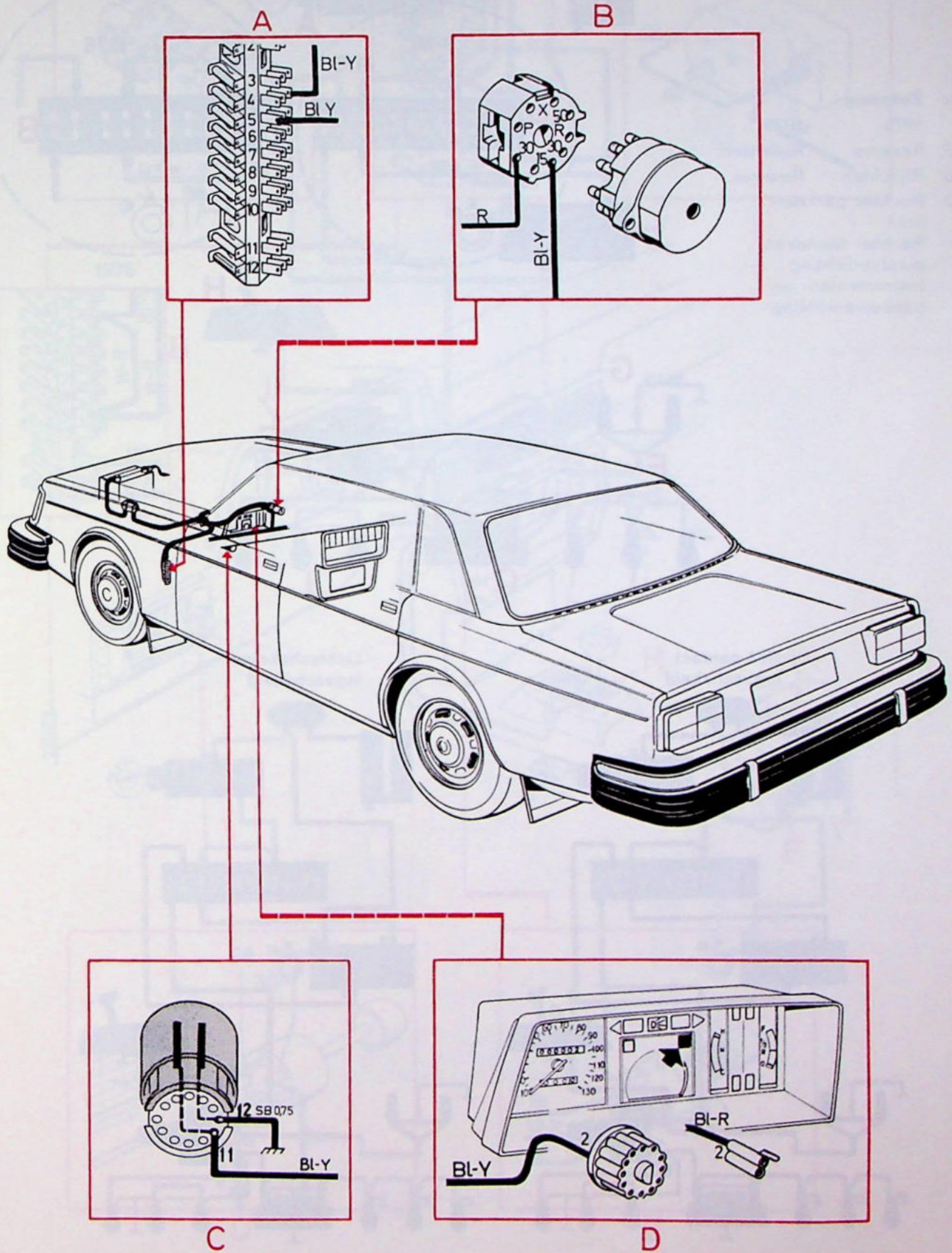

# Verlichting instrumenten en bedieningsorganen

Nr	Zekering	1975	1976
9	Reserve	Rijlichten	
10	Rijlichten	Reserve	
12	Rechter parkeerlicht		
		Rechter kentekenplaatverlichting	
		Instrumenten- en paneelverlichting	

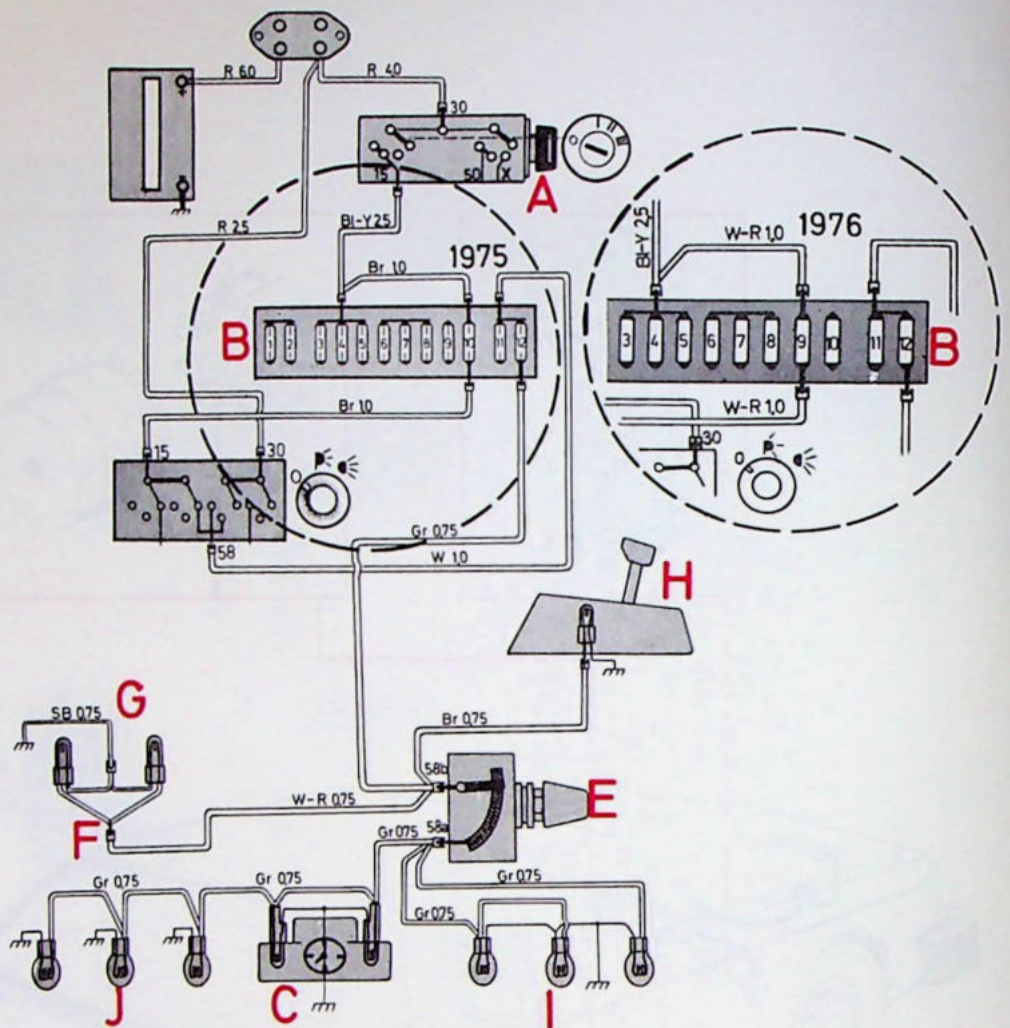

Het contact ingeschakeld

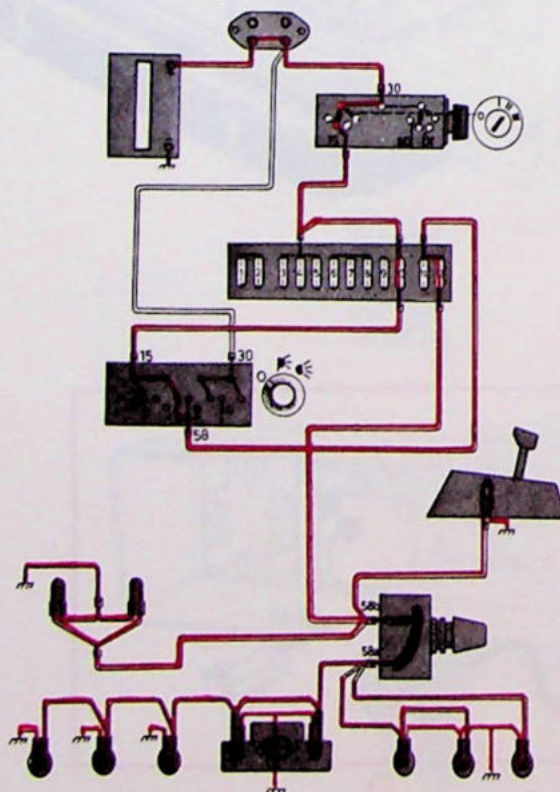

Lichtschakelaar ingeschakeld

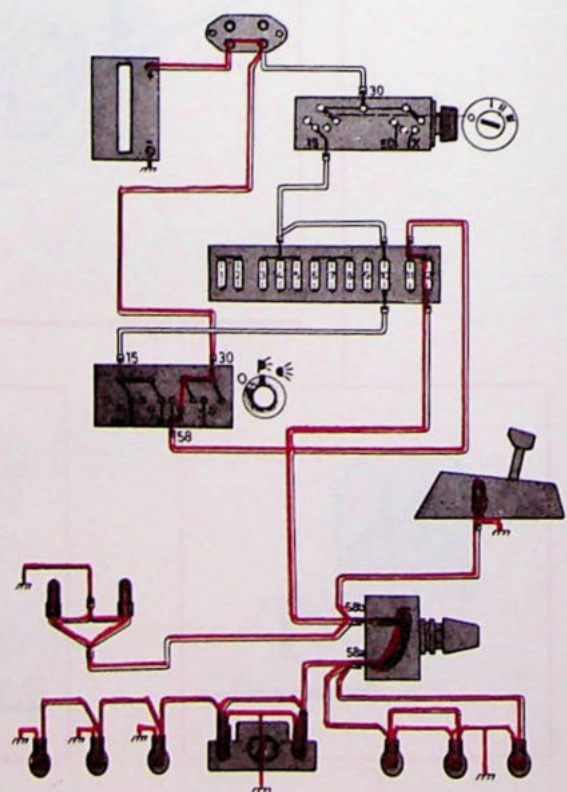

# Verlichting instrumenten en bedieningsorganen

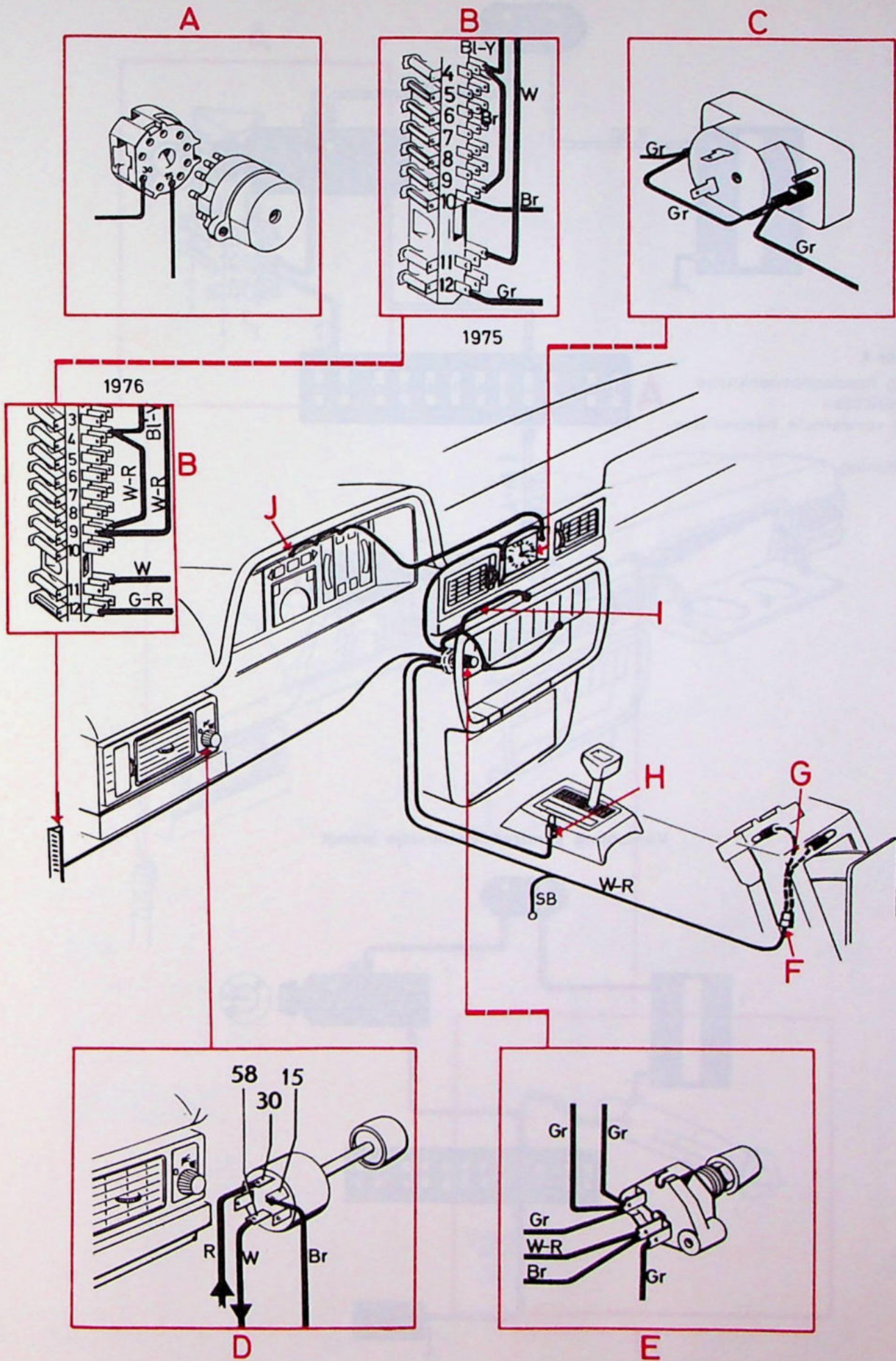

# Verlichting handschoenenkastje

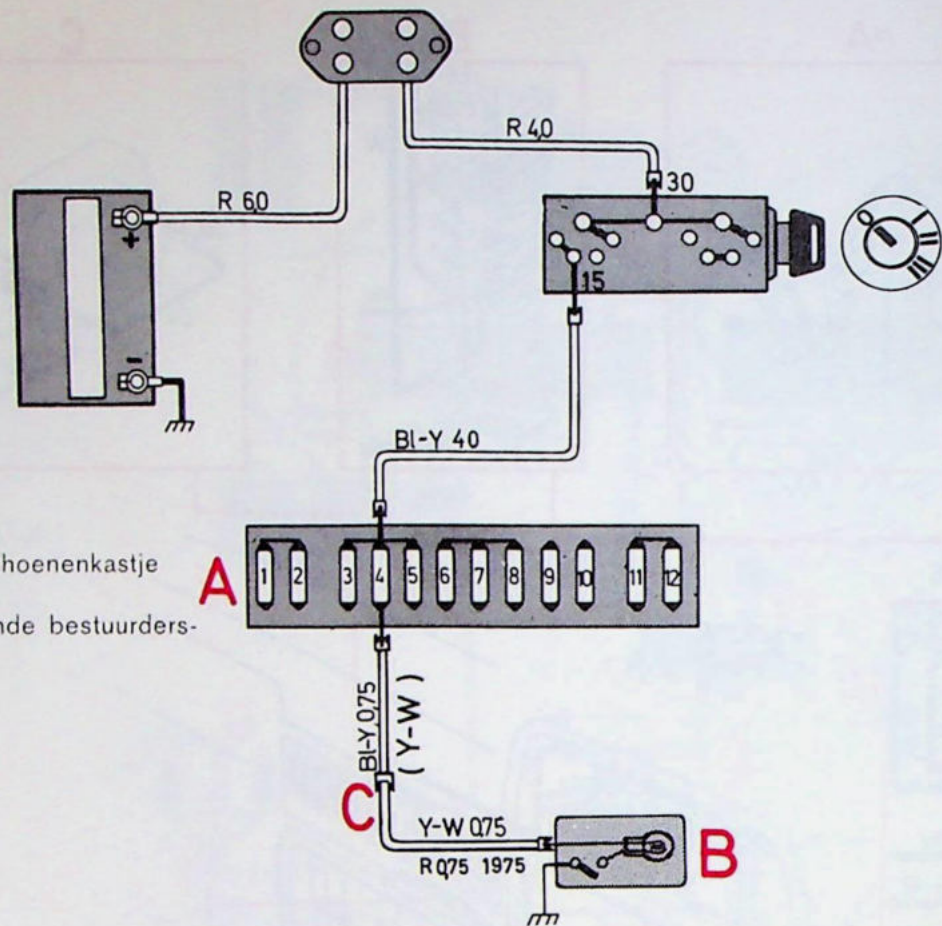

## Zekering nr 4

Verlichting handschoenenkastje  
 Achteruitrijlichten  
 Elektrisch verwarmde bestuurders-  
 stoel  
 Air-conditioning

**A**

**B**

## Verlichting handschoenenkastje brandt

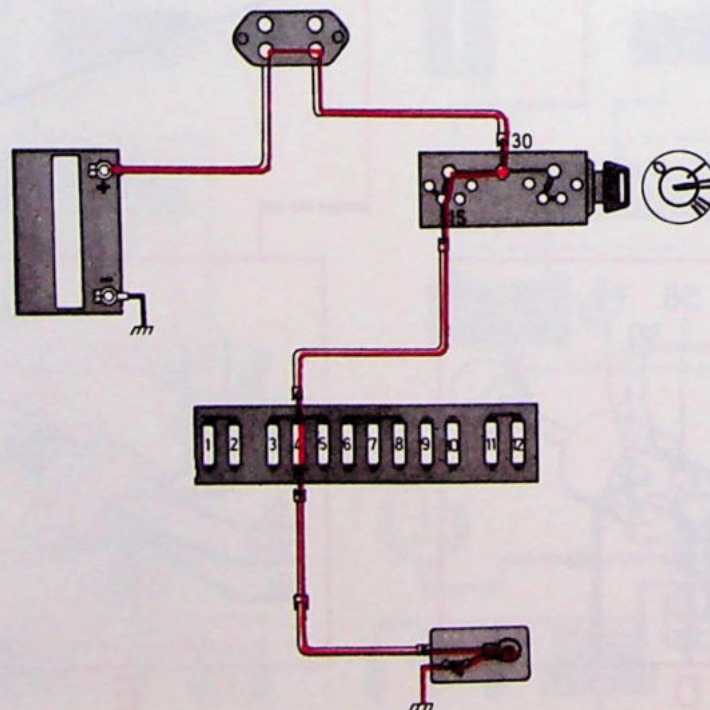

# Verlichting handschoenenkastje

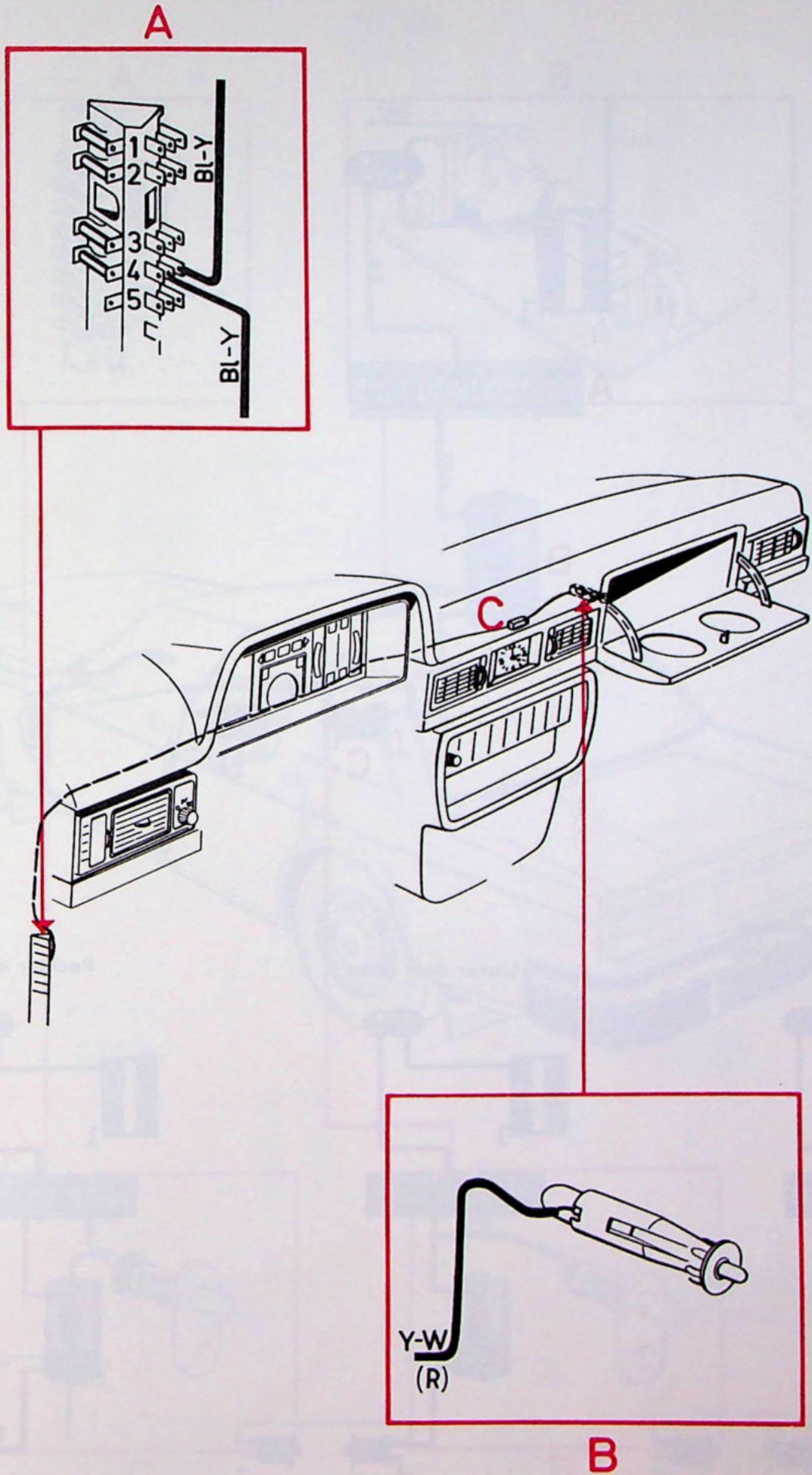

# Interieurverlichting

Zekering nr 8  
 Stoplichten  
 Interieurverlichting

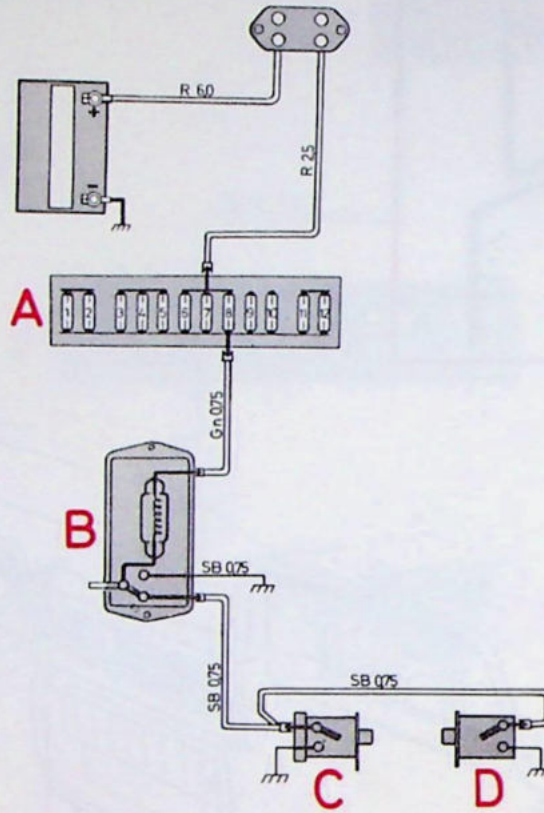

Deuren gesloten  
 Binnenverlichting  
 brandt

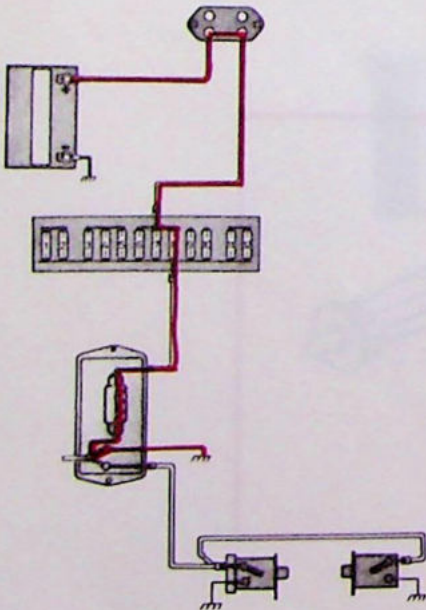

Linker deur open

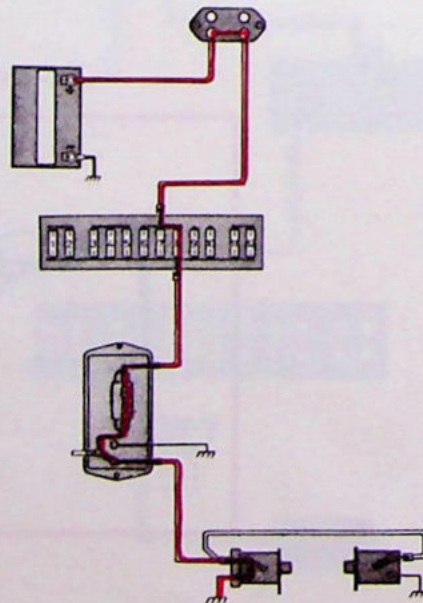

Rechter deur open

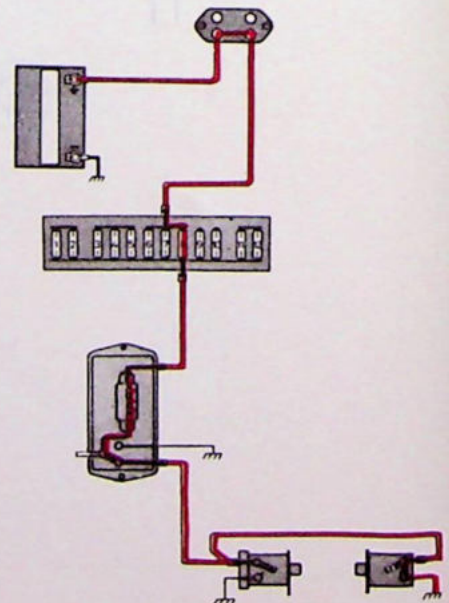

# Interieurverlichting

A

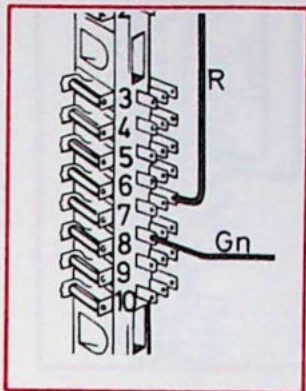

B

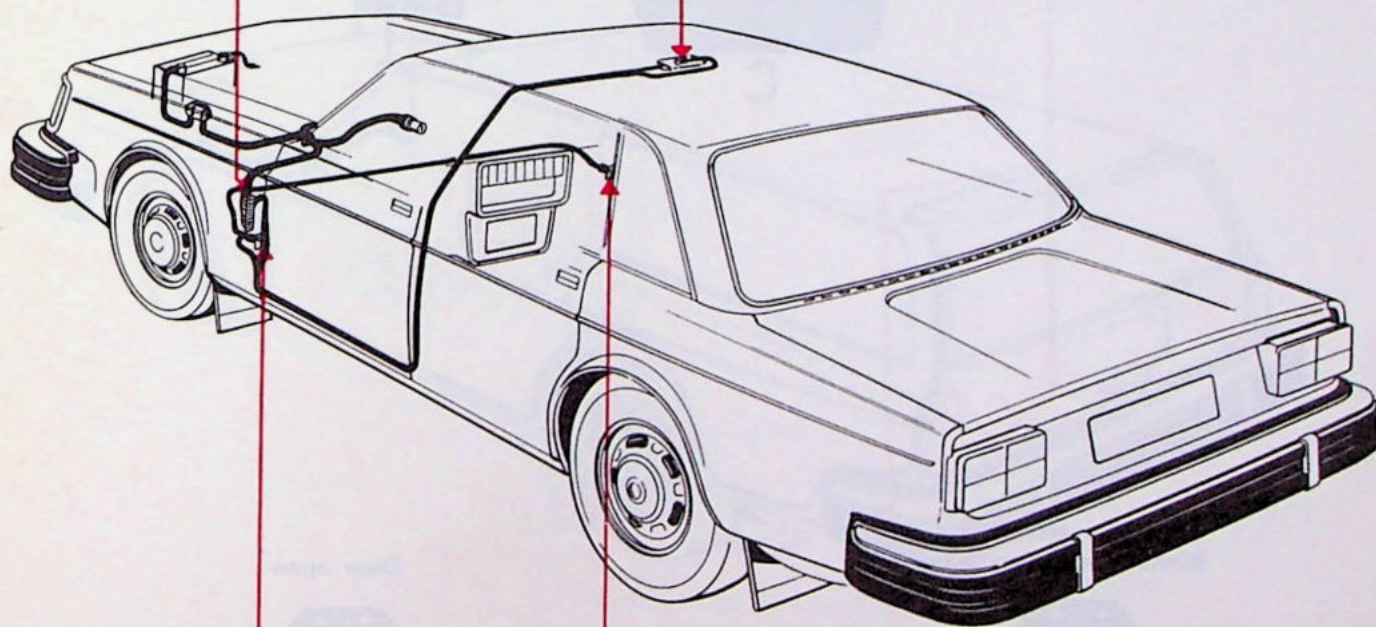
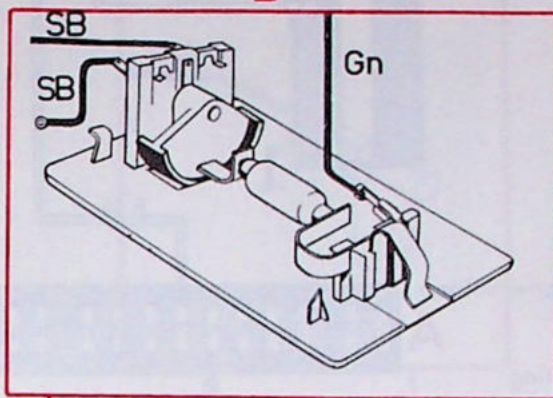

C

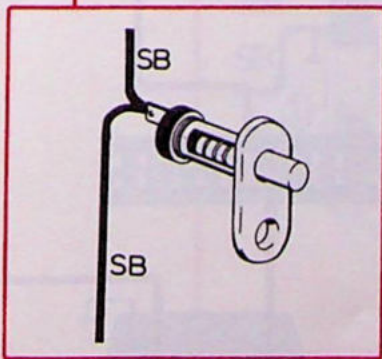

D

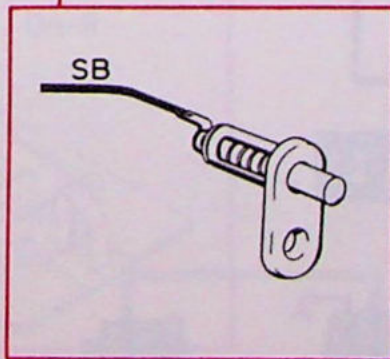

# Interieurverlichting, 245 achter

Zekering nr 6  
 Waarschuingsknipperlichten  
 Achterste interieur-  
 verlichting (245)  
 Motorruimteverlichting

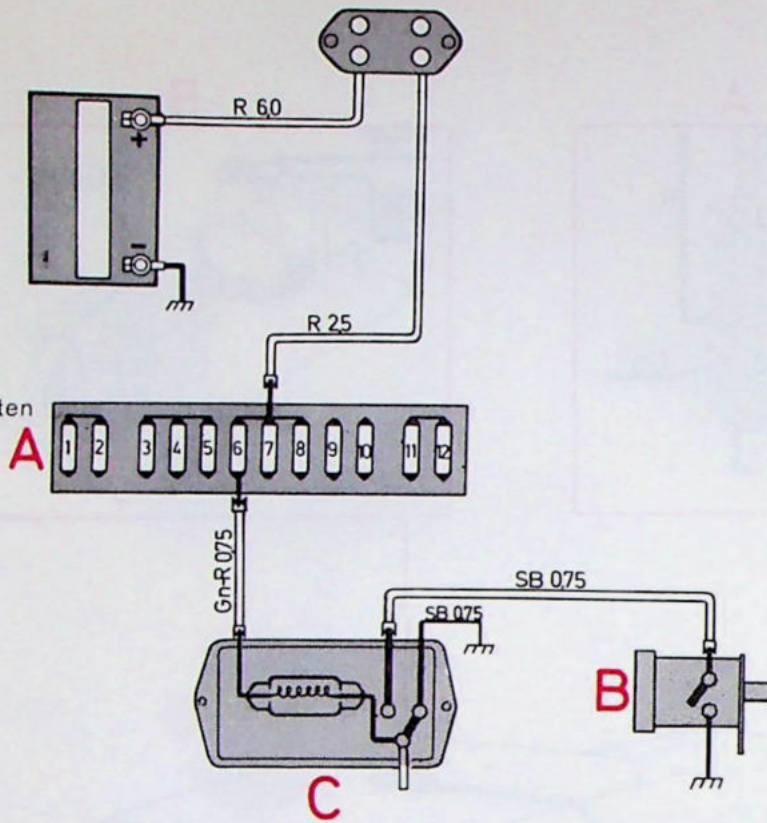

Deur gesloten  
 Binnenverlichting brandt

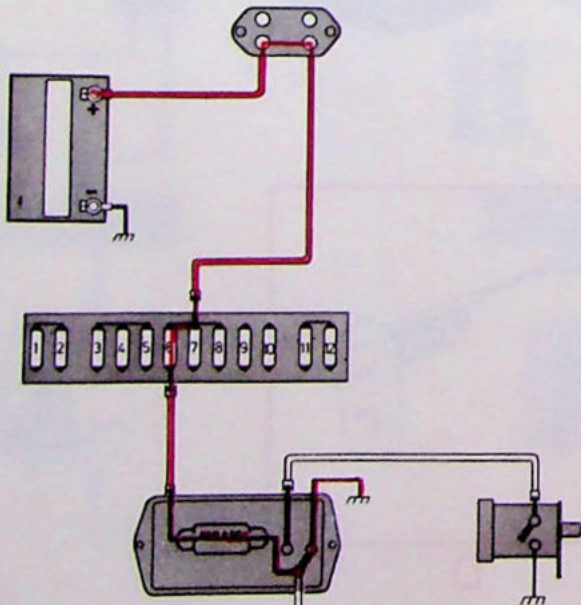

Deur open

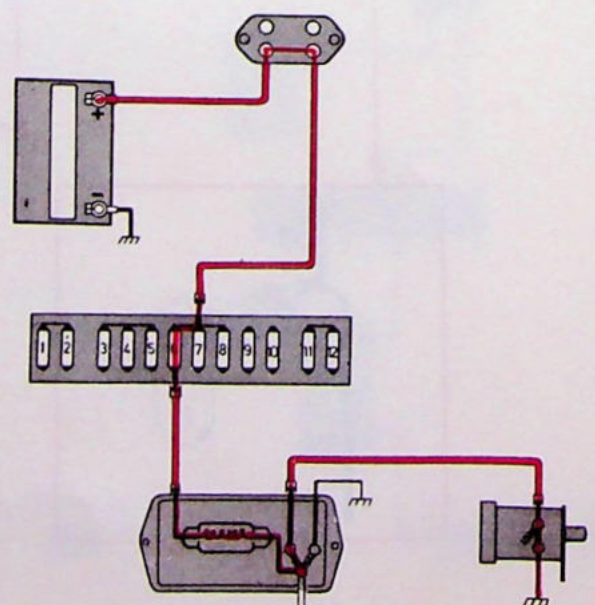

# Interieurverlichting, 245 achter

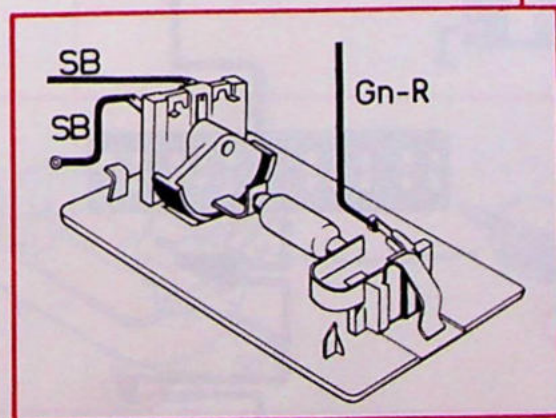
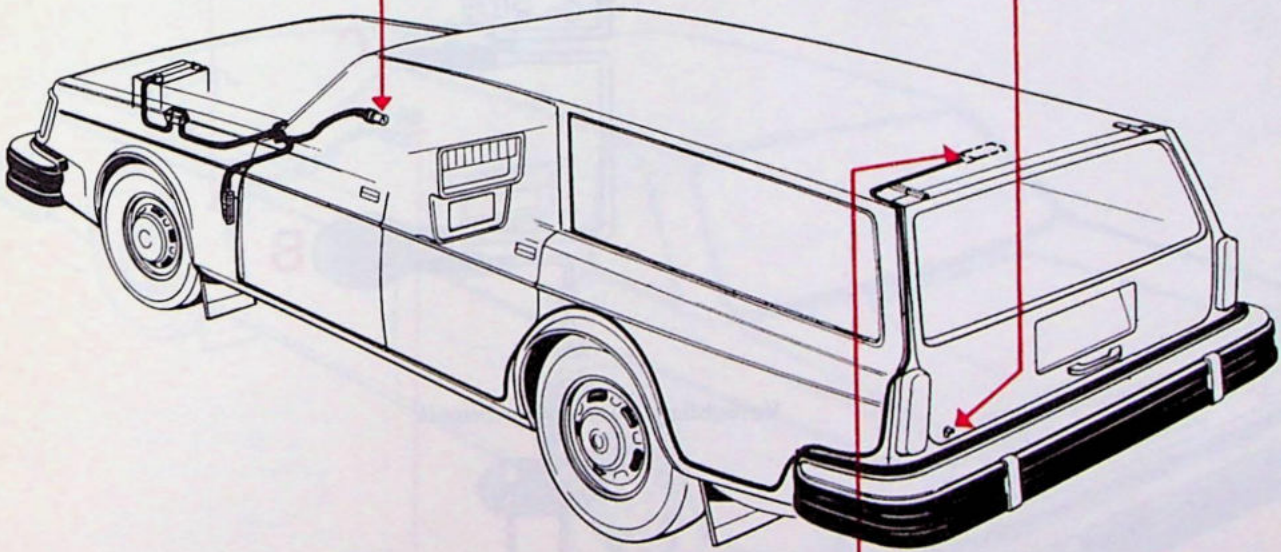
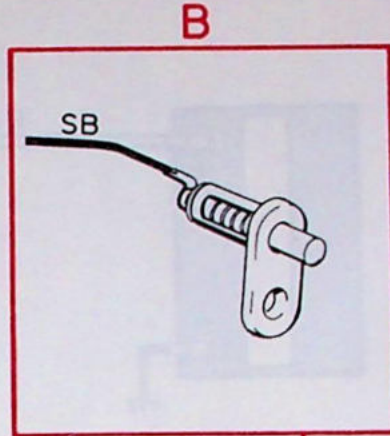
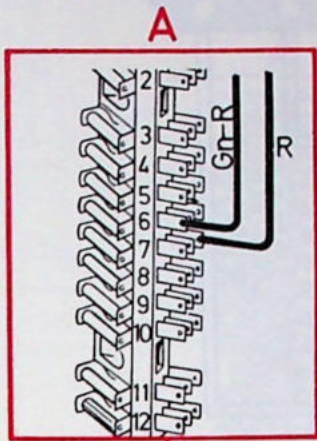

# Motorruimteverlic

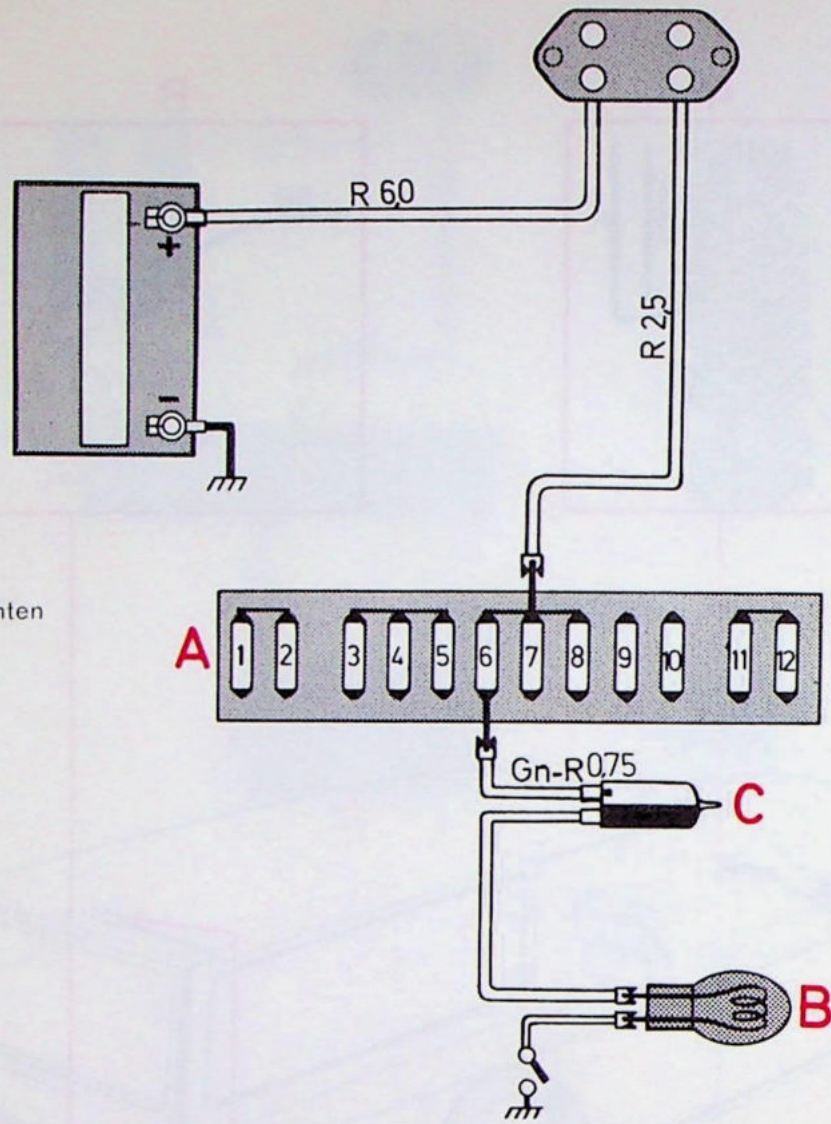

Zekering nr 6  
Waarschuwingsknipperlichten  
Achterste interieur-  
verlichting (245)  
Motorruimteverlichting

Verlichting motorruimte brandt

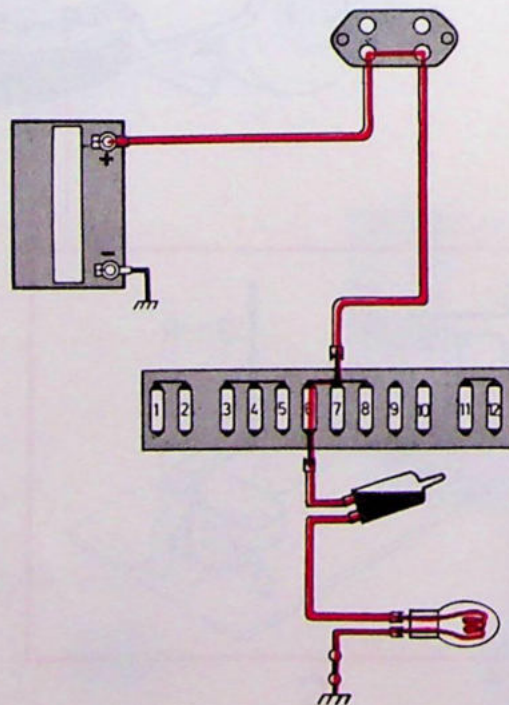

# Motorruimteverlichting

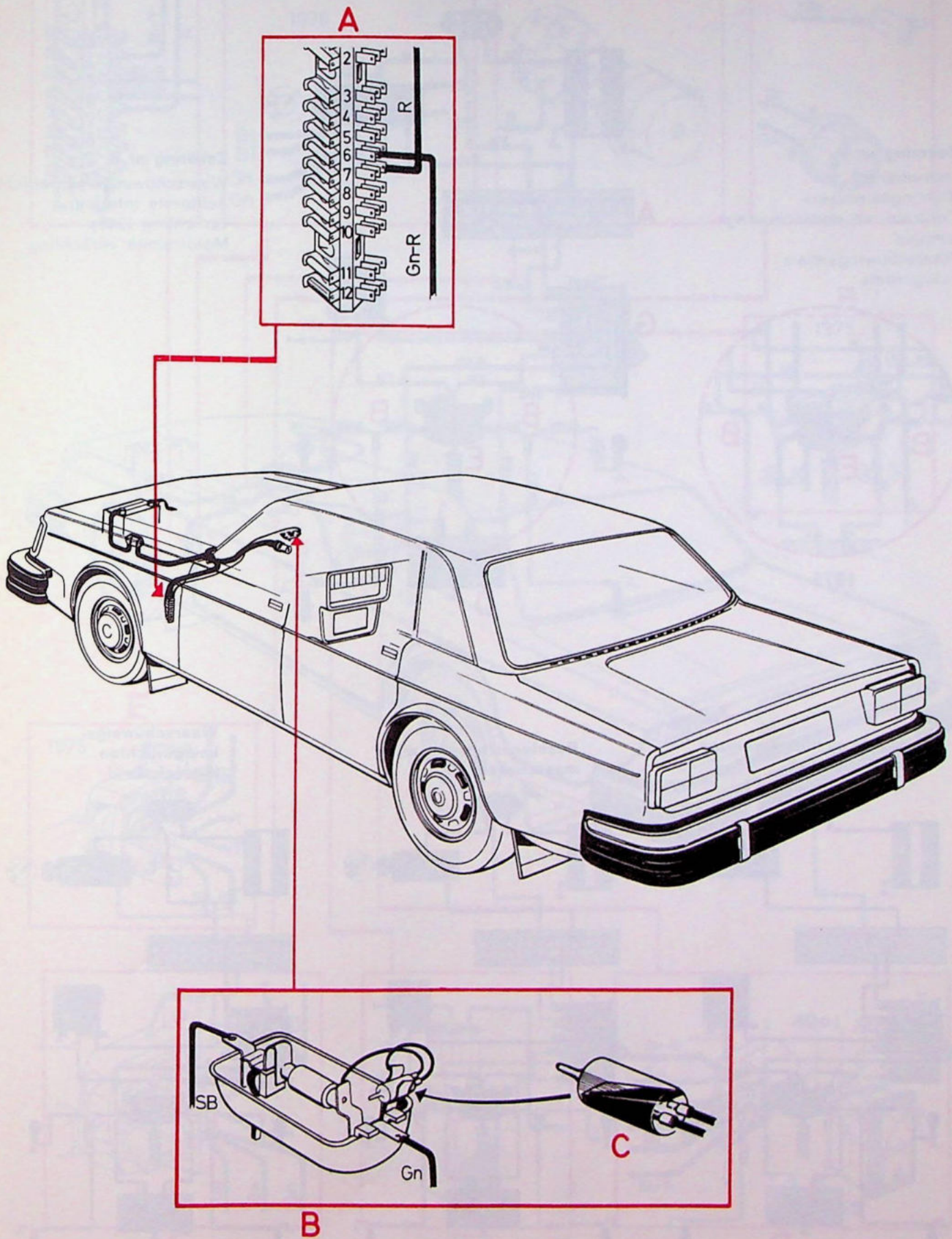

# Richtingaanwijzers en waarschuwingsknipperlichten

## Zekering nr 5

Instrumenten  
Richtingaanwijzers  
Controle- en waarschuwings-  
lampjes  
Waarschuwingsrelais  
autogordels

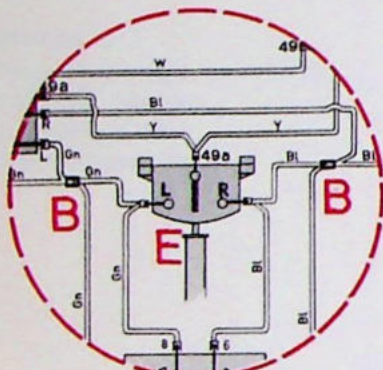

1975

## Zekering nr 6

Waarschuwingsknipperlichten  
Achterste interieur-  
verlichting (245)  
Motorruimte verlichting

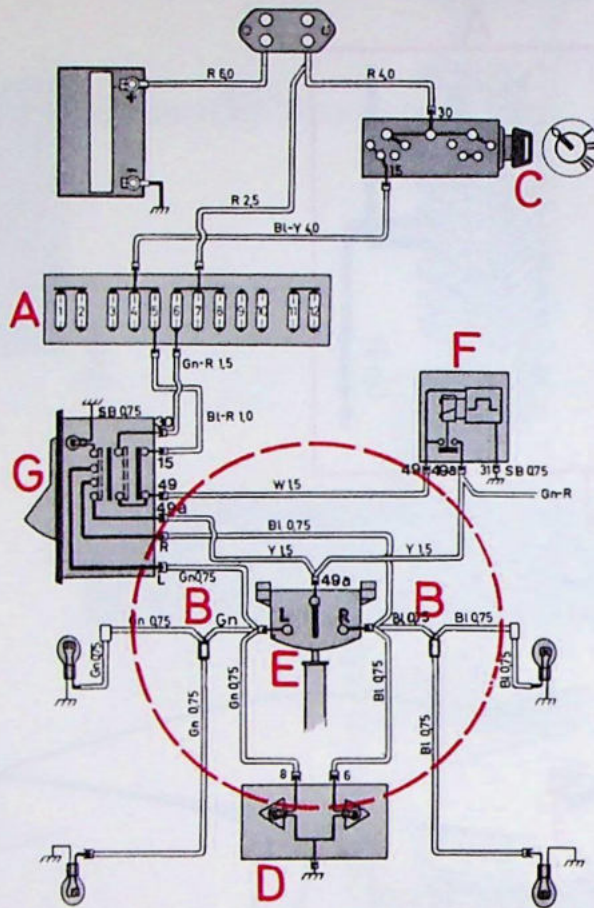

Linker richtingaanwijzer  
ingeschakeld

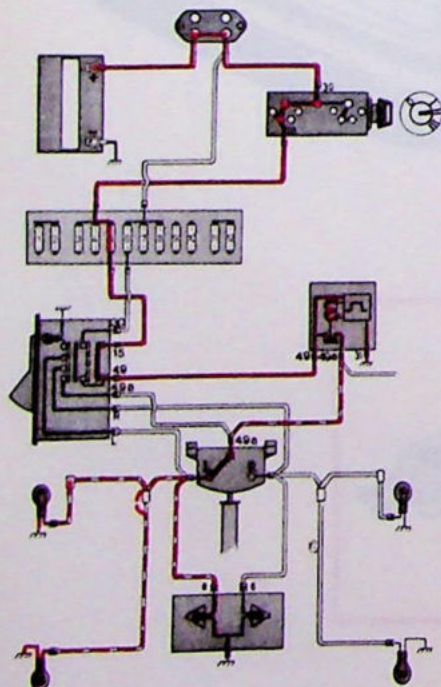

Rechter richtingaanwijzer  
ingeschakeld

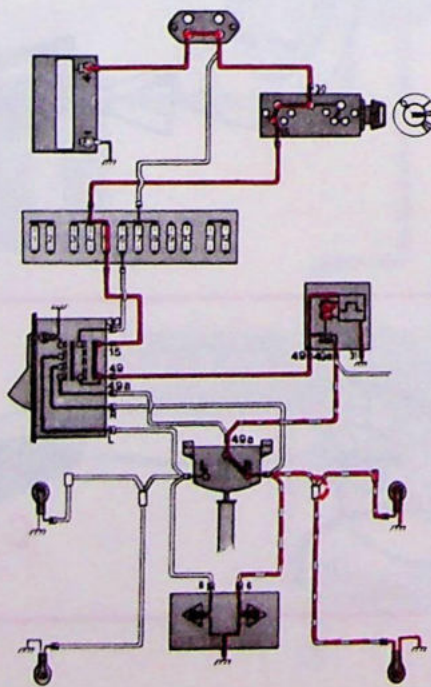

Waarschuwings-  
knipperlichten  
ingeschakeld

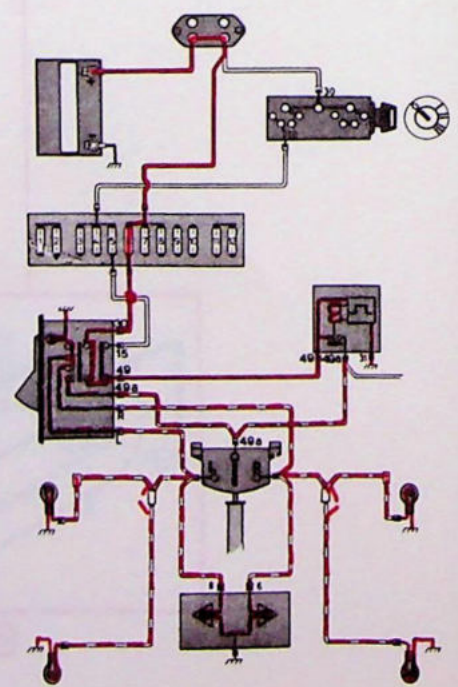

# Richtingaanwijzers en waarschuwingsknipperlichten

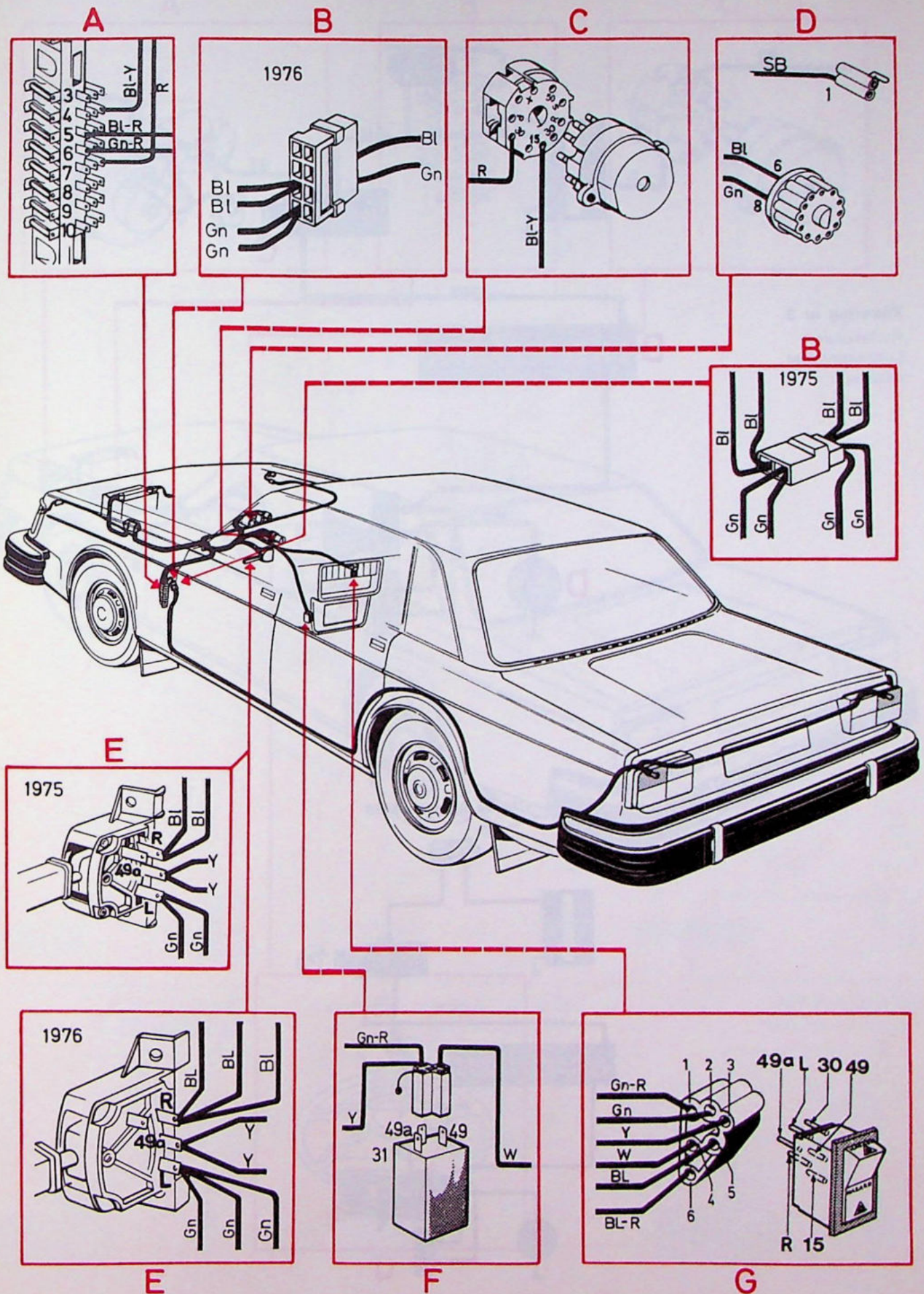

# Claxon

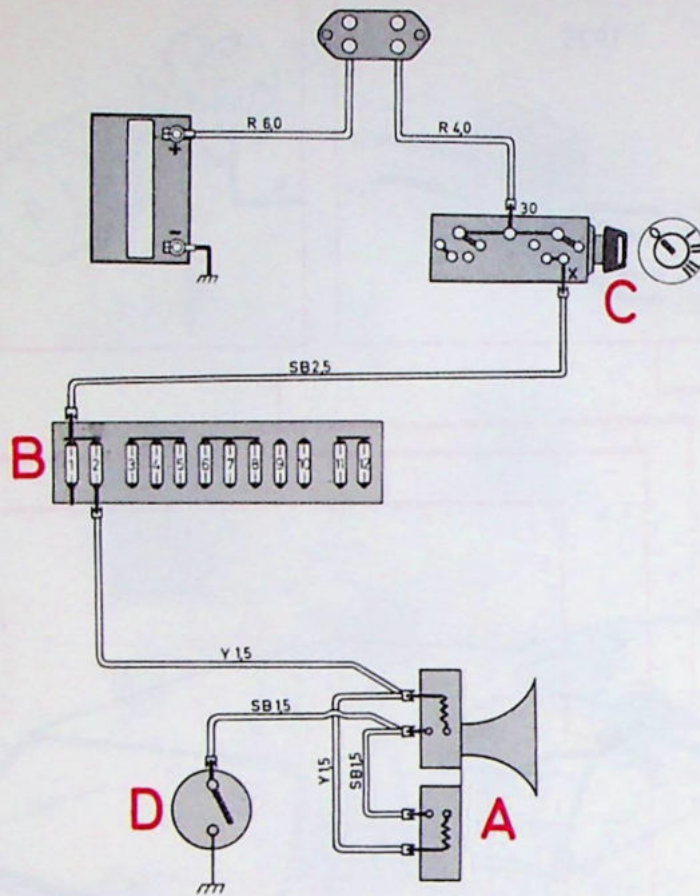

Zekering nr 2  
Ruitewissers  
Luchtaanjager  
Claxon

Claxon ingeschakeld

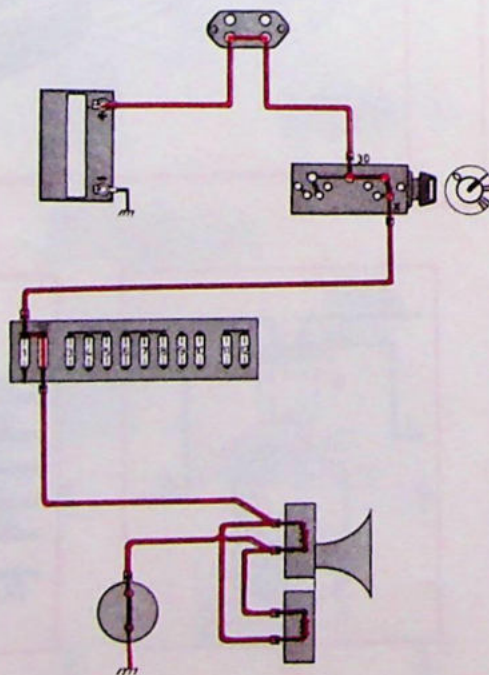

# Claxon

A

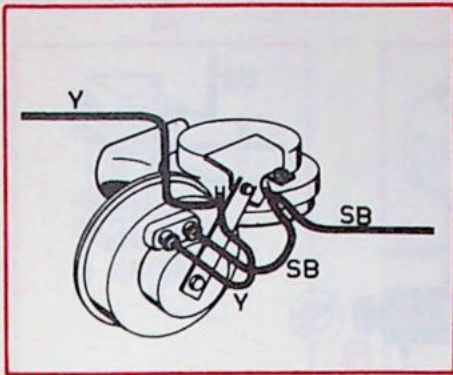

B

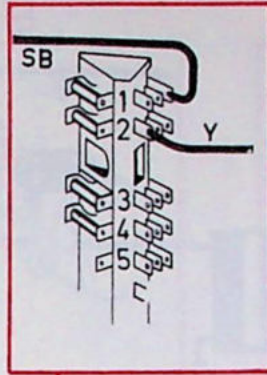

C

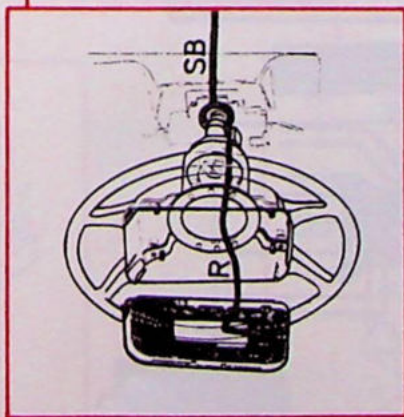
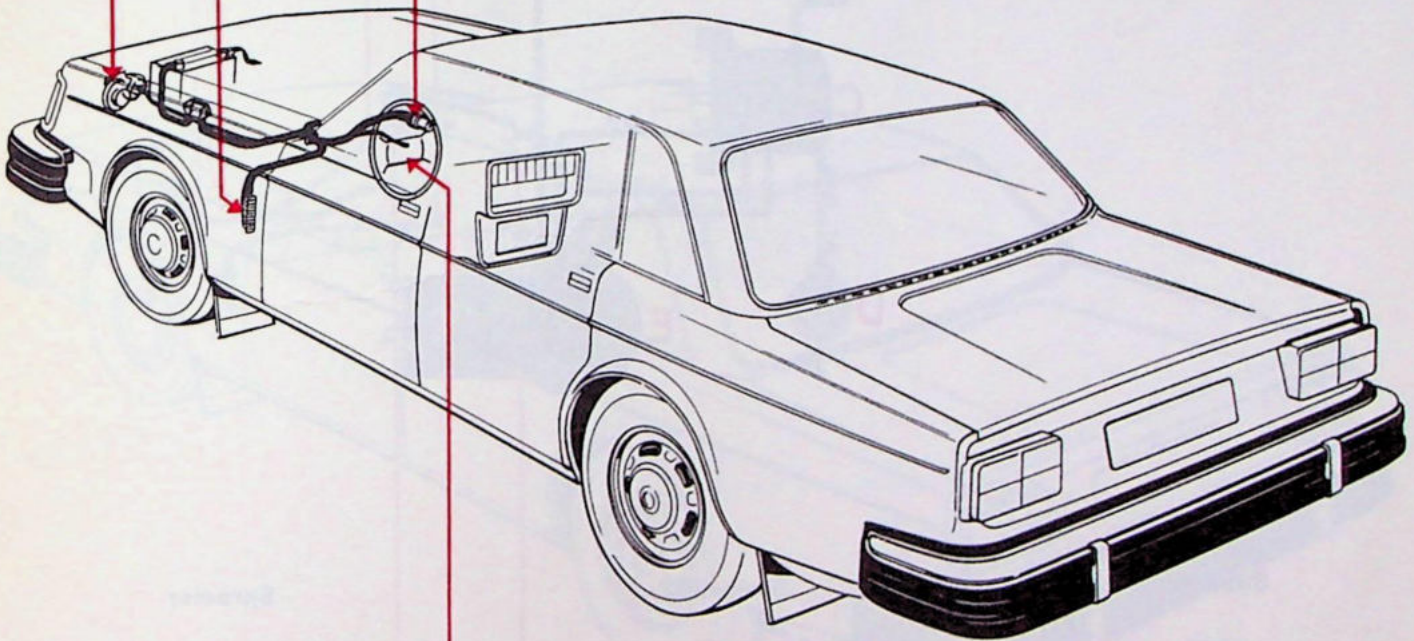
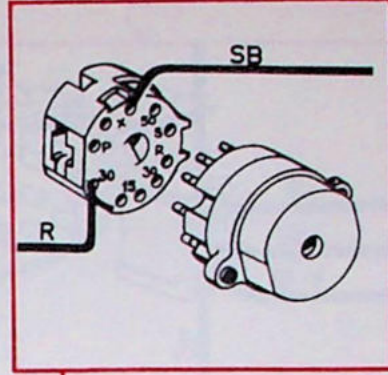

D

# Ruitwissers en -sproeiers

Zekering nr 2  
Ruitwissers  
Luchtaanjager  
Claxon

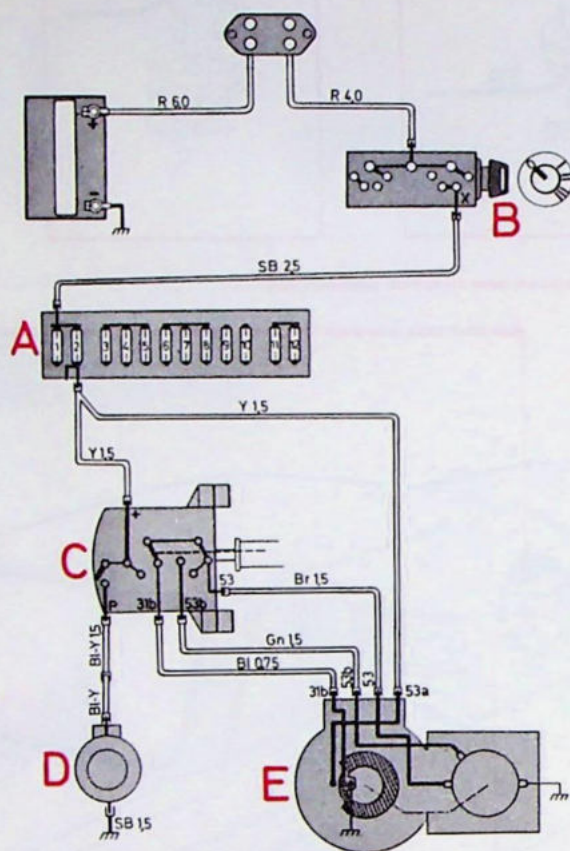

Snelheid 1

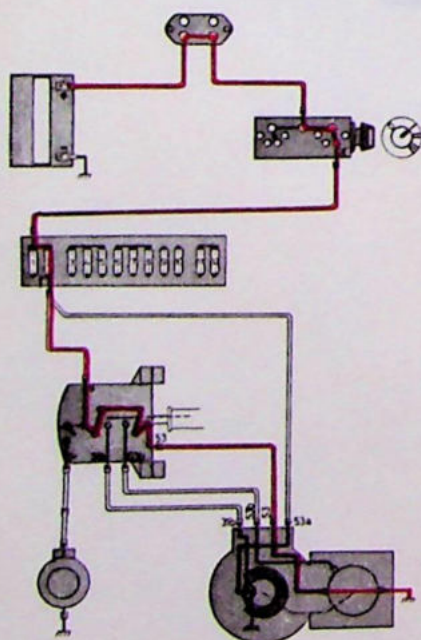

Snelheid 2

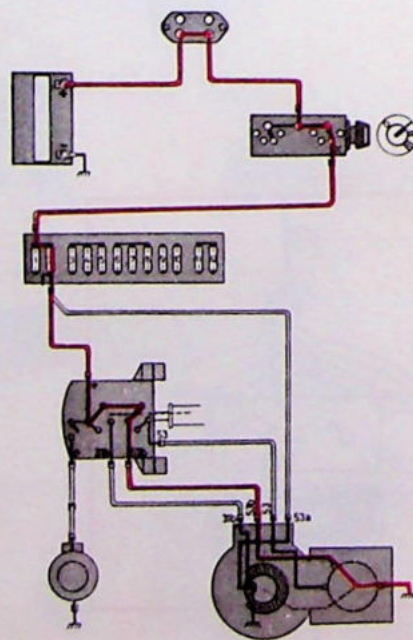

Sproeier

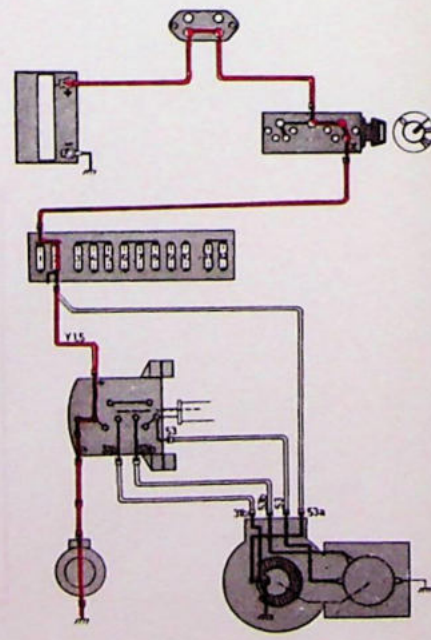

# Ruitwissers en -sproeiers

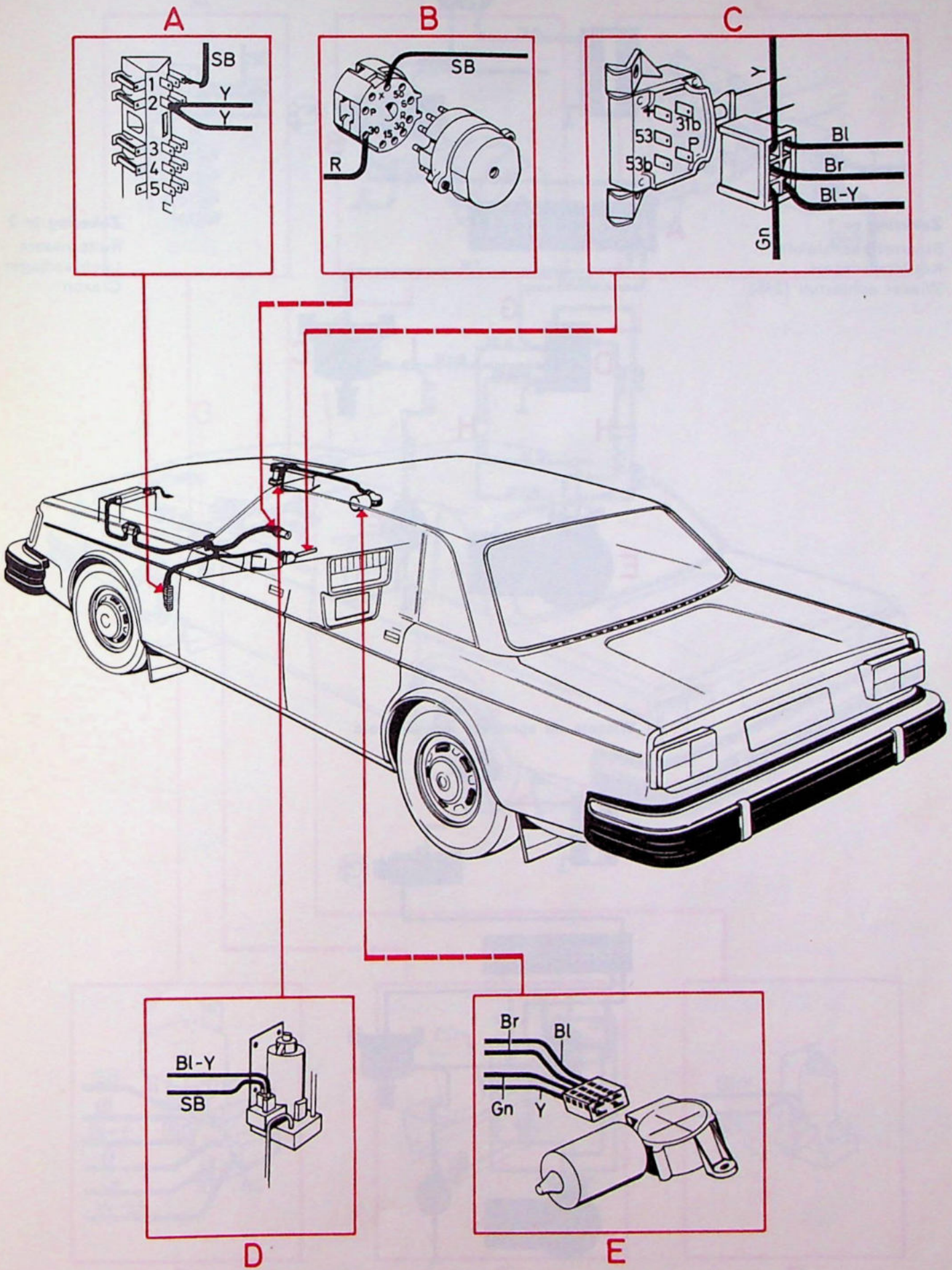

# Koplampwissers en -sproeiers

**Zekering nr 1**  
 Sigaretteaansteker  
 Koplampwissers  
 Wisser achterrait (245)

**Zekering nr 2**  
 Ruitwissers  
 Luchtaanjager  
 Claxon

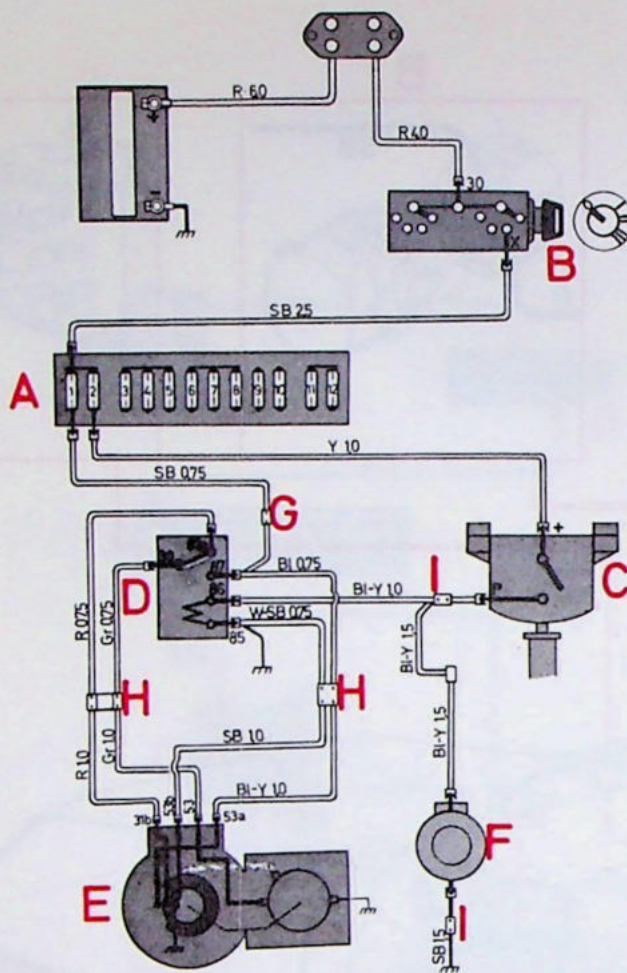

Wissers en sproeiers ingeschakeld

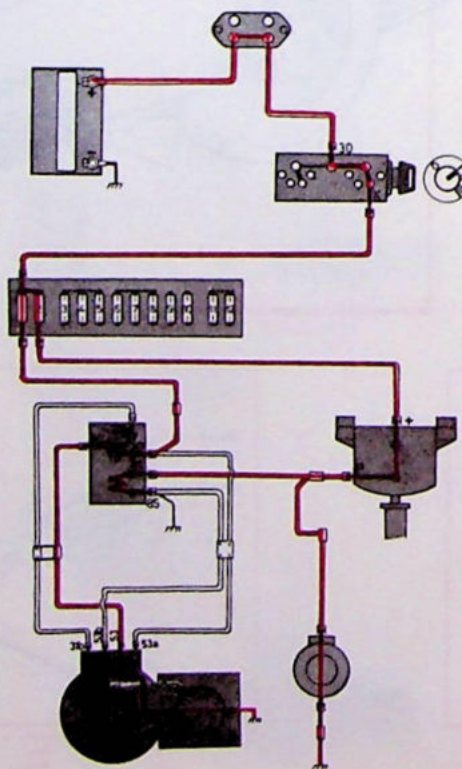

# Koplampwissers en -sproeiers

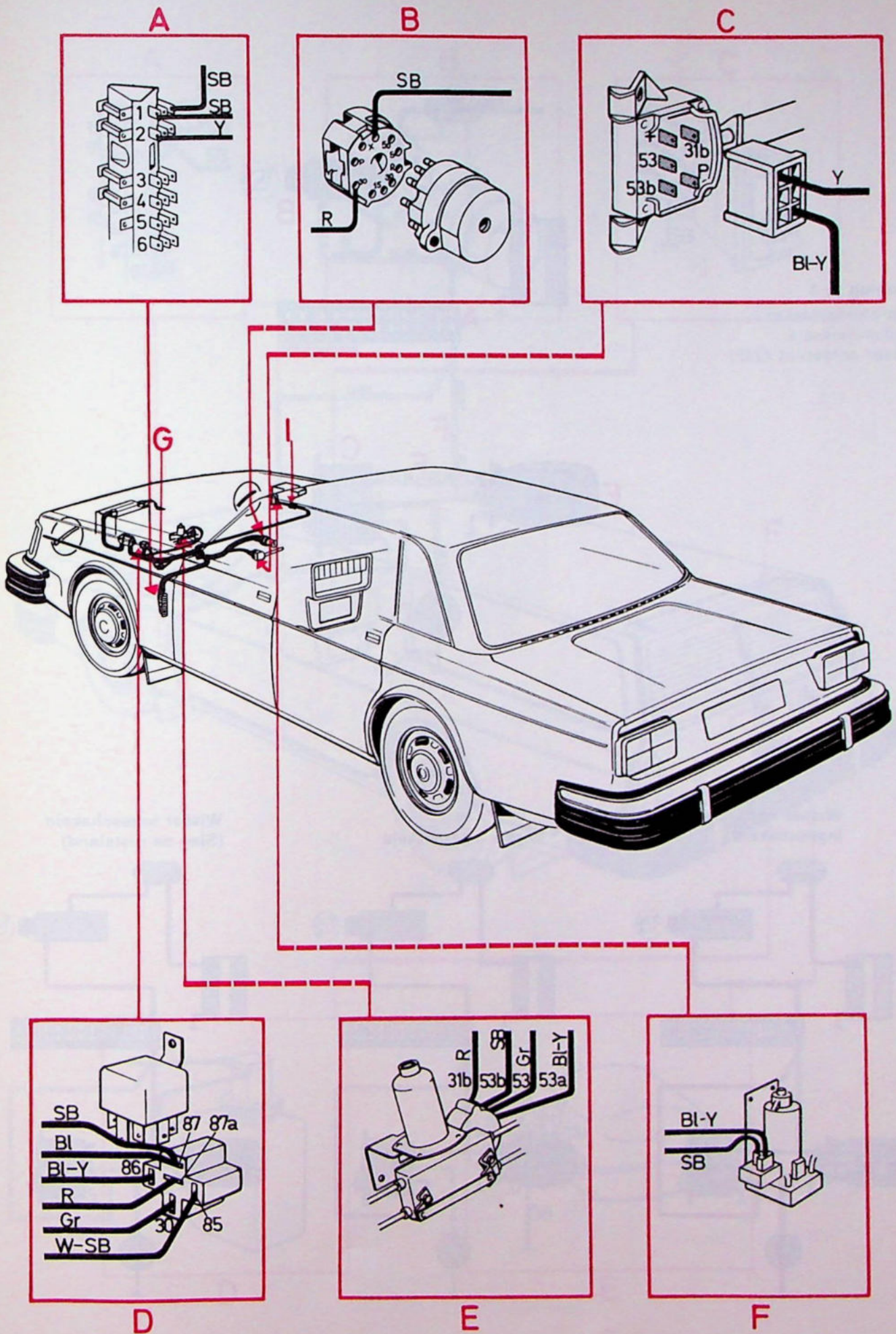

# Ruitwissers en -sproeier, achterrait

Zekering nr 1  
 Sigaretteaansteker  
 Koplampwissers  
 Wisser achterrait (245)

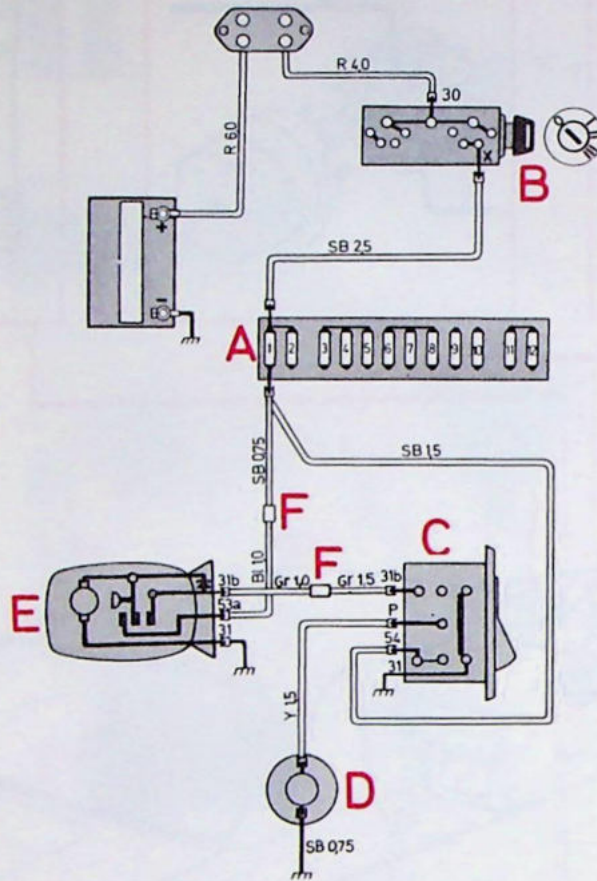

Wisser en sproeier  
 ingeschakeld

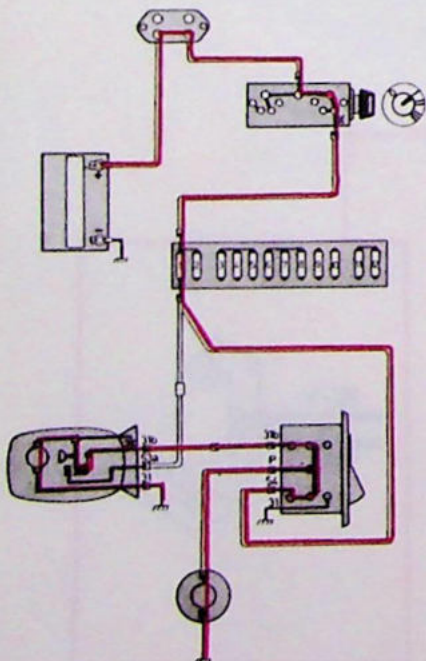

Wisser ingeschakeld

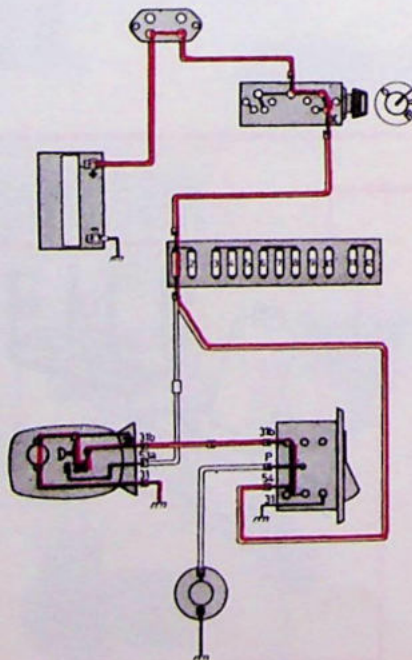

Wisser ingeschakeld  
 (Slag na ruststand)

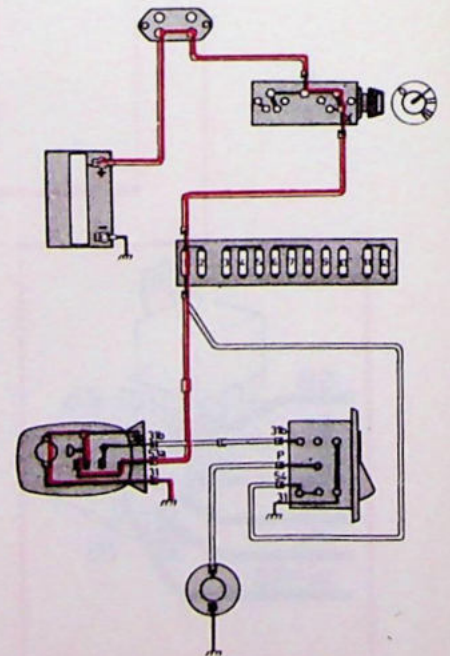

# Ruitewissers en -sproeier, achterruit

A

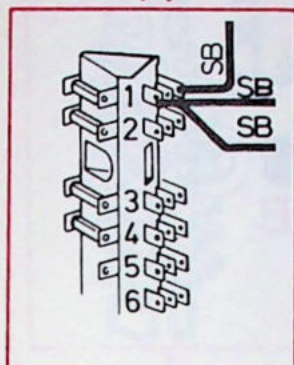

B

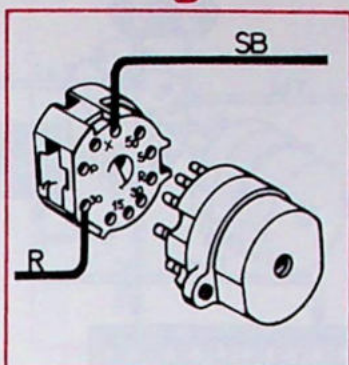

C

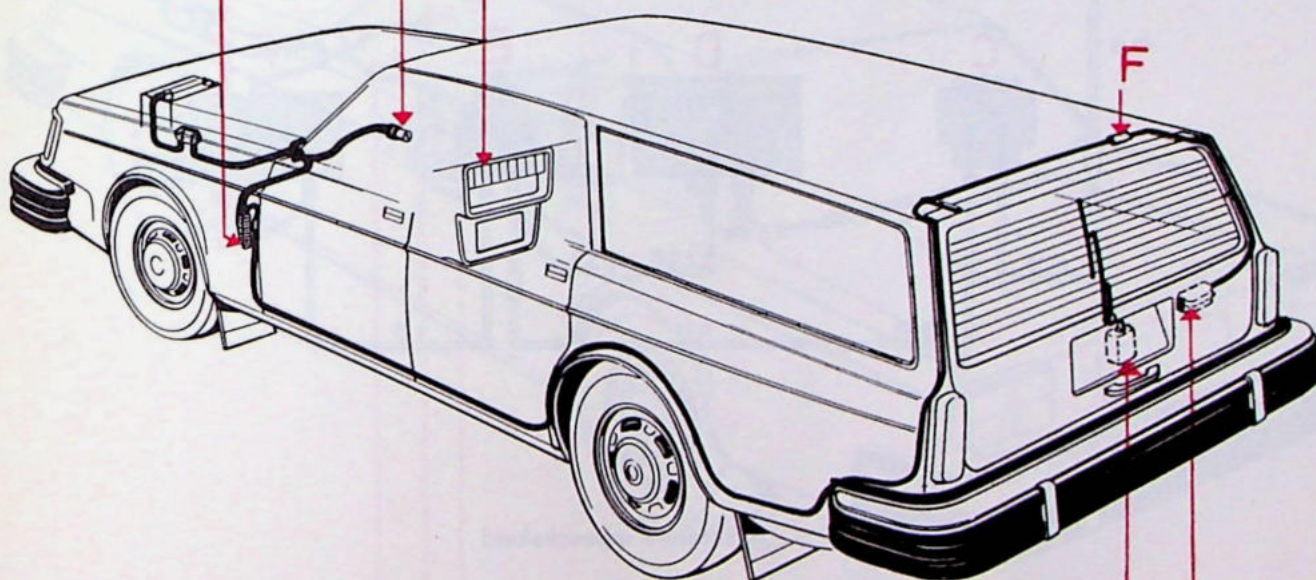
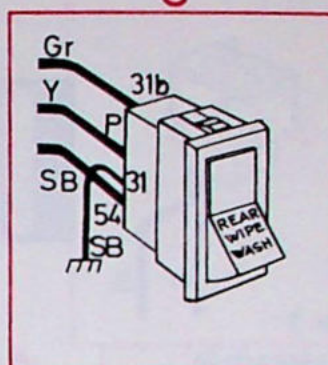

F

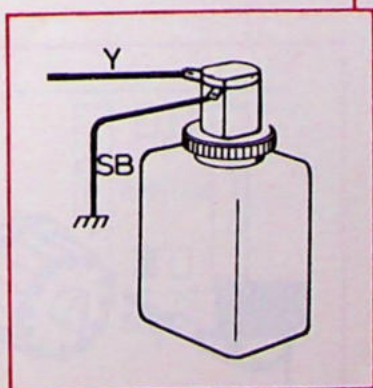

D

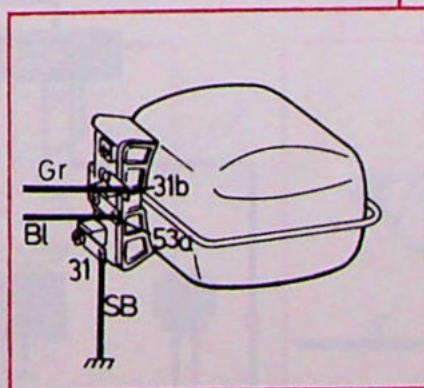

E

# Overdrive

Zekering nr 3  
Elektrisch verwarmde  
achterrait  
Overdrive

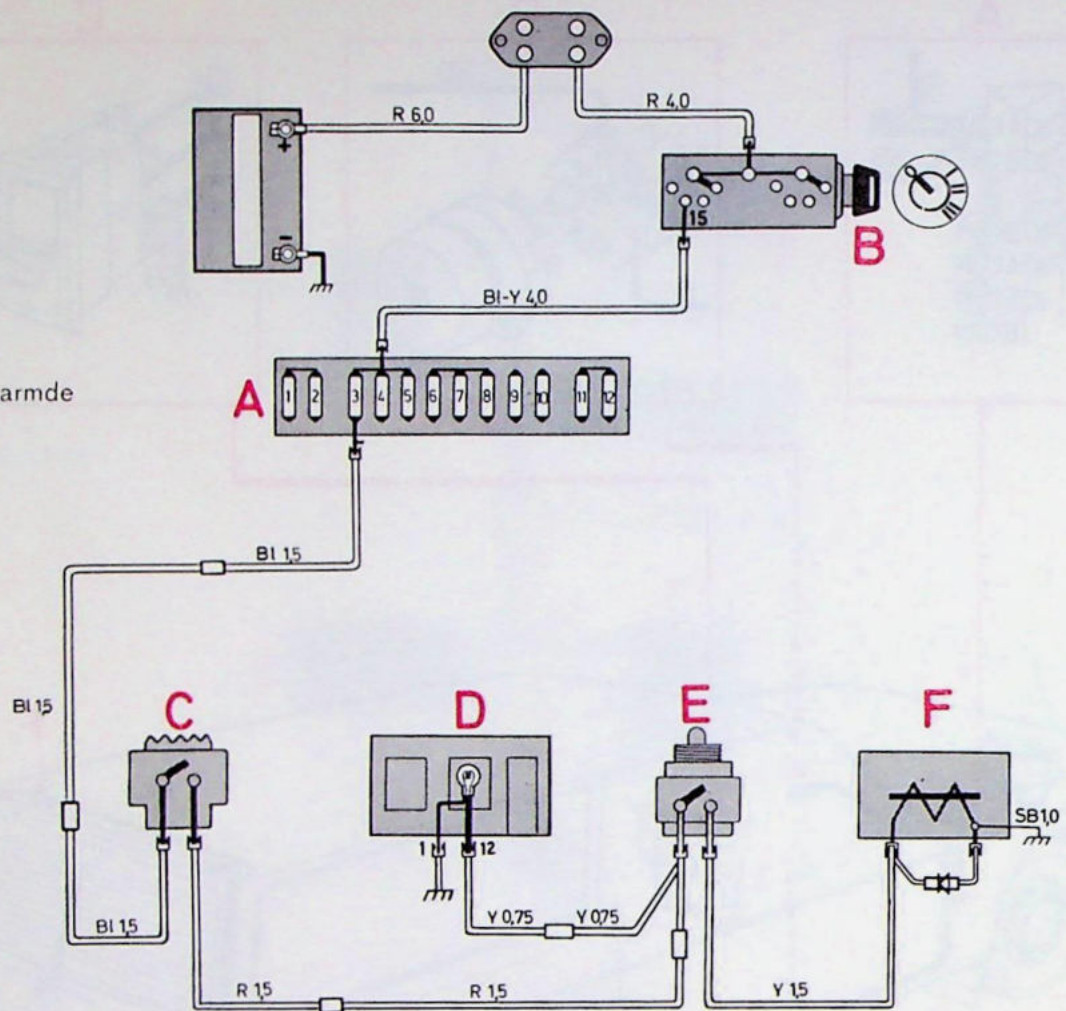

Overdrive ingeschakeld

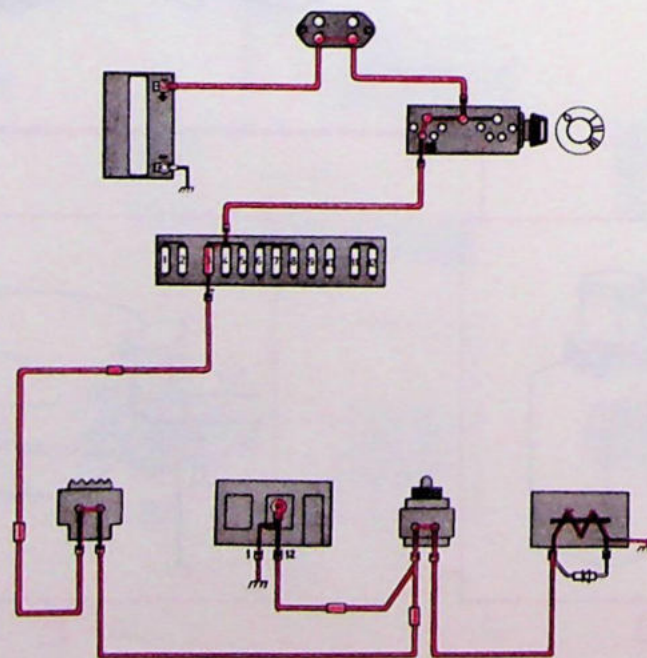

# Overdrive

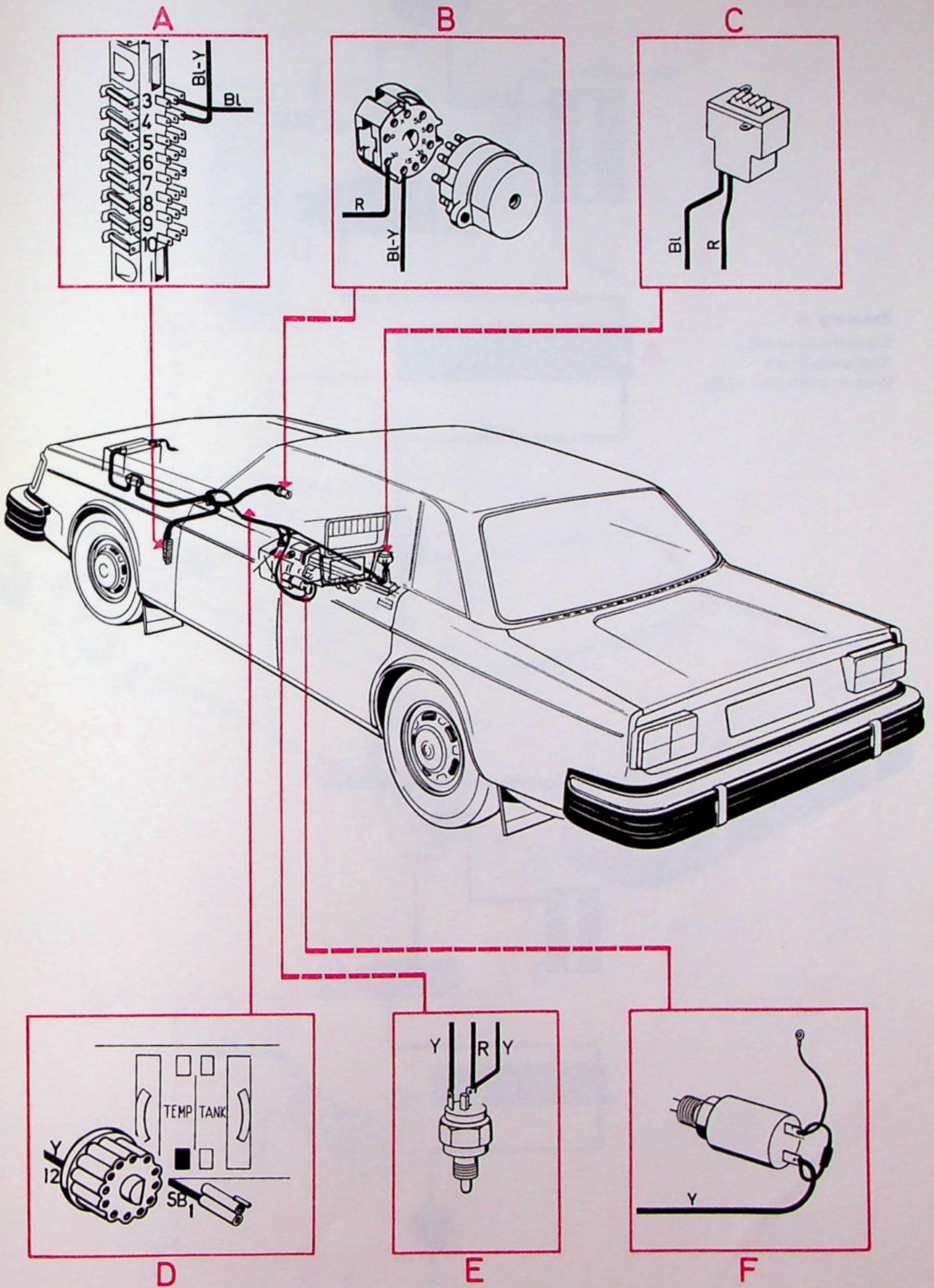

# Sigaretteaansteker

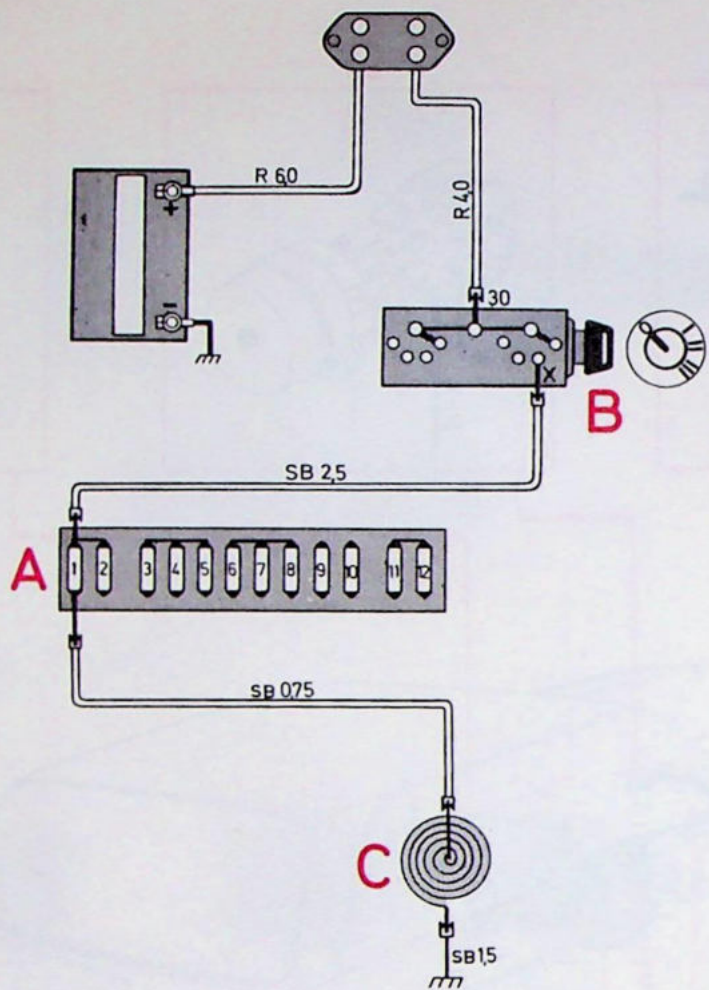

Zekering nr 1  
Sigaretteaansteker  
Koplampwissers  
Wisser achterraut (245)

Sigaretteaansteker ingeschakeld

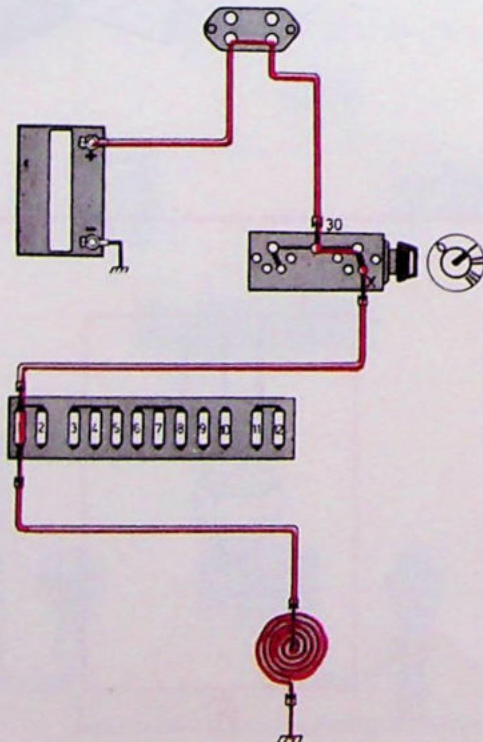

# Sigaretteaansteker

A

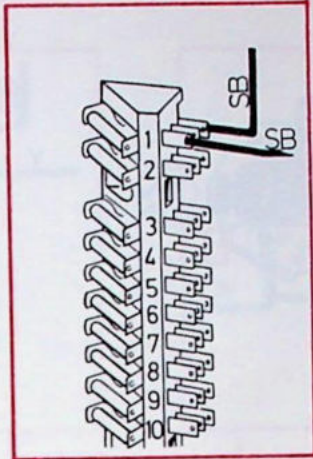

B

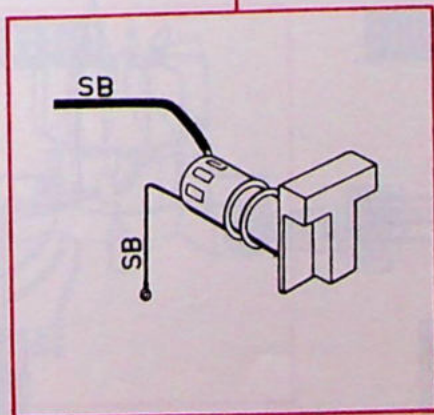
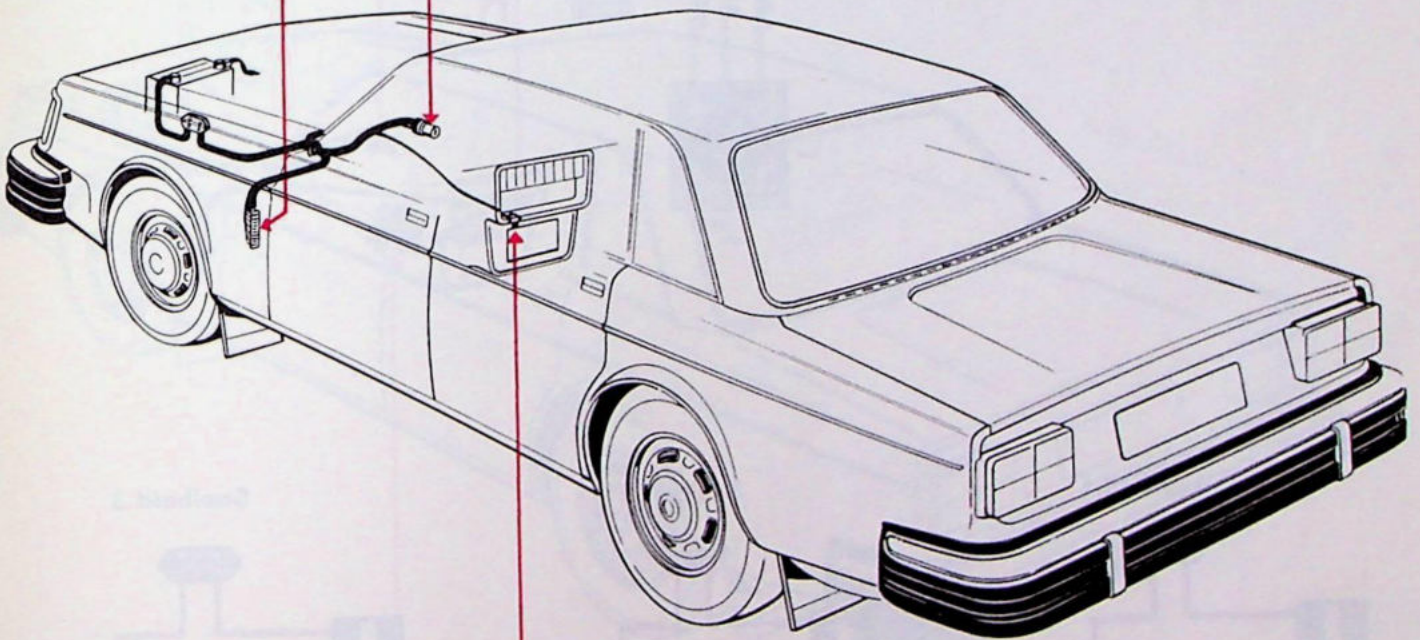
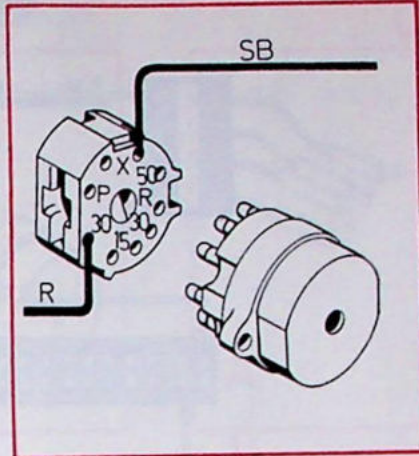

C

# Luchtaanjager "standaardverwarming"

Zekering nr 2  
Ruitewissers  
Luchtaanjager  
Claxon

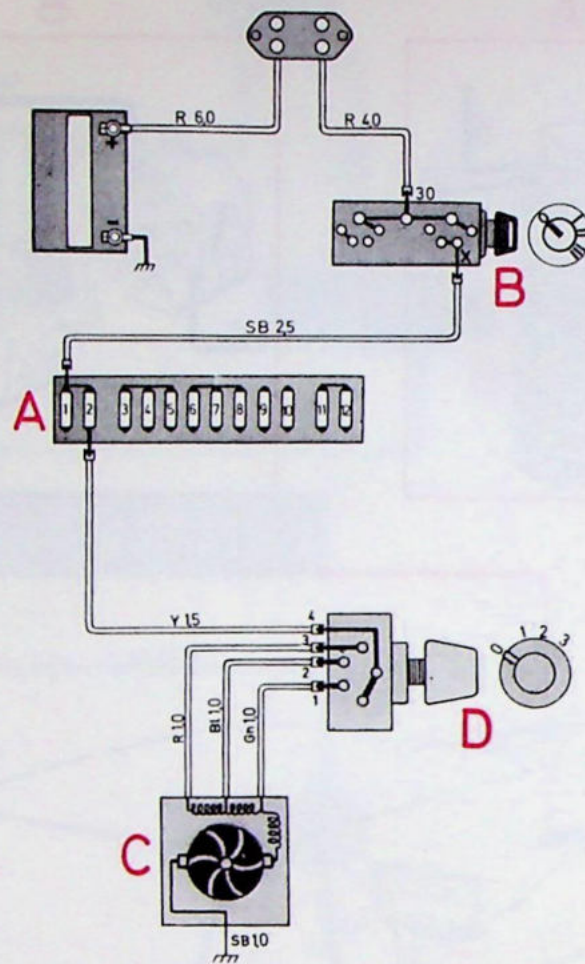

Snelheid 1

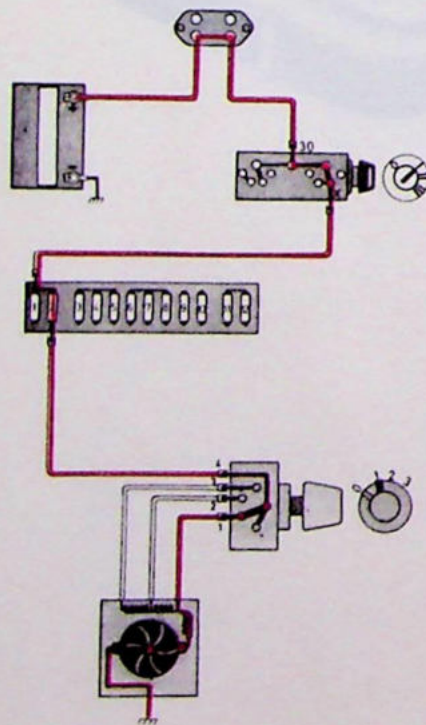

Snelheid 2

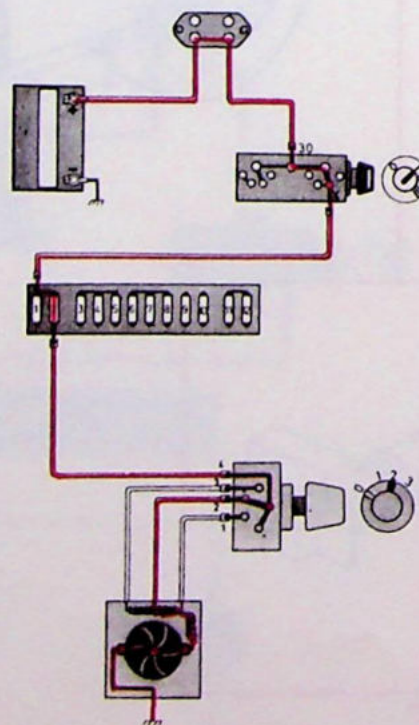

Snelheid 3

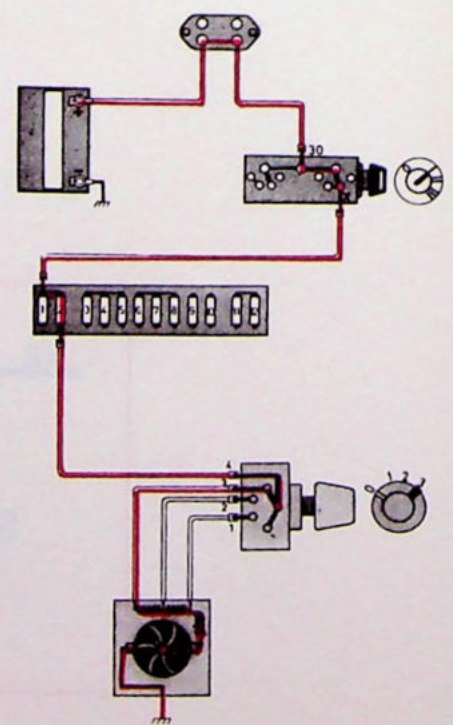

# Luchtaanjager "standaardverwarming"

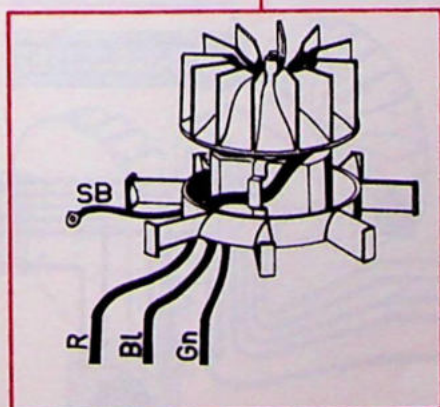
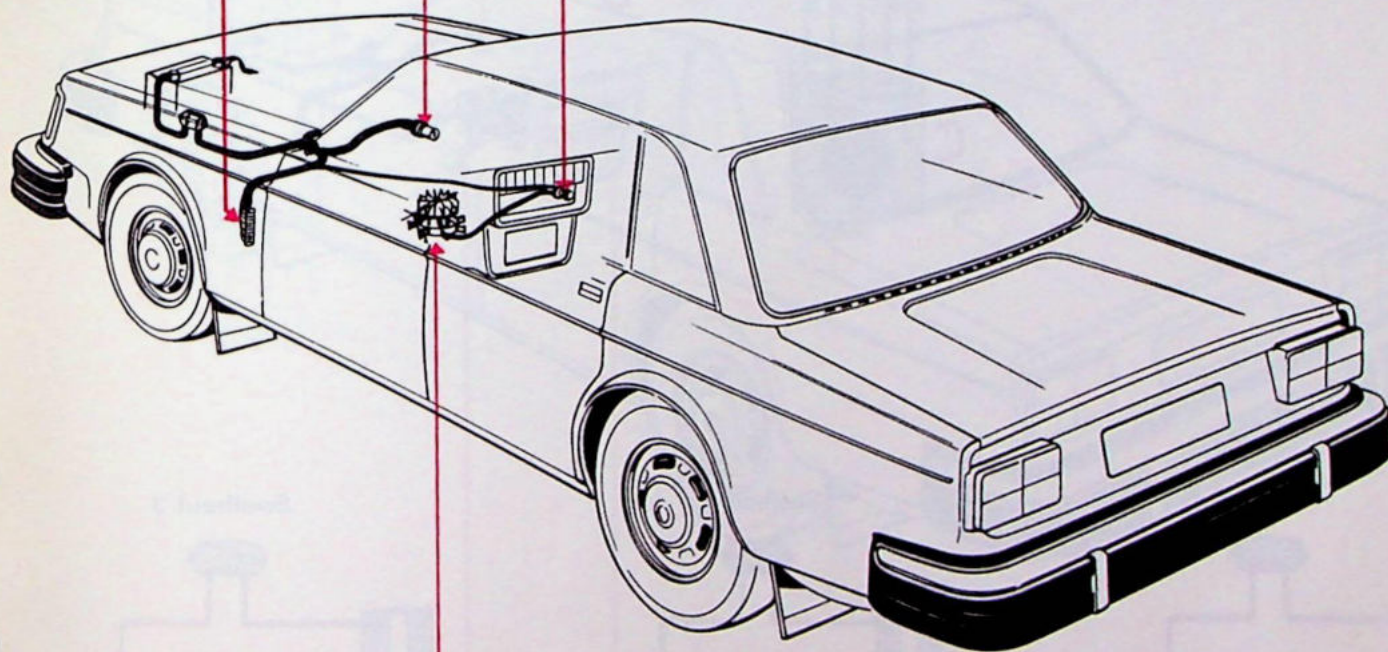
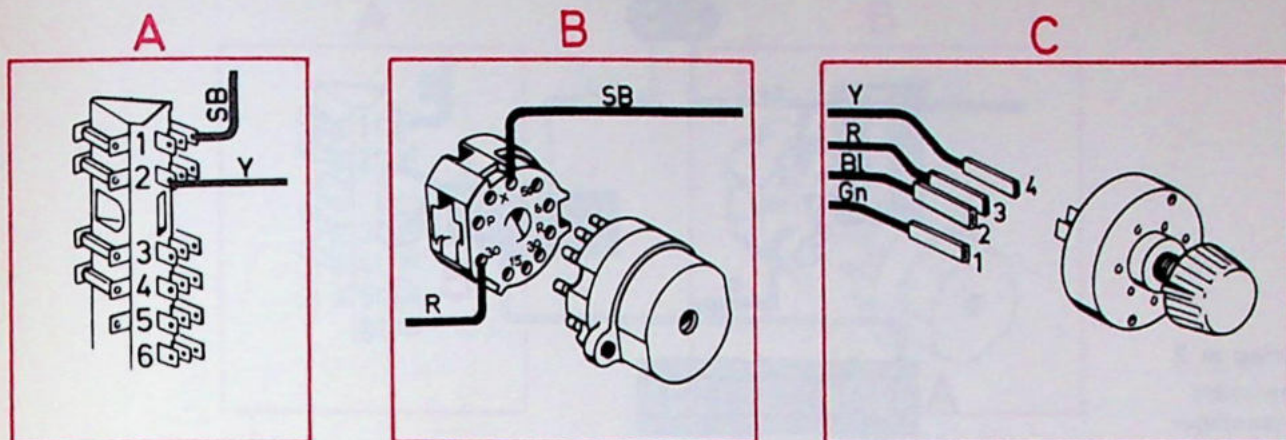

D

# Luchtaanjager gecombineerd verw.systeem

Zekering nr 2  
Ruitwissers  
Luchtaanjager  
Claxon

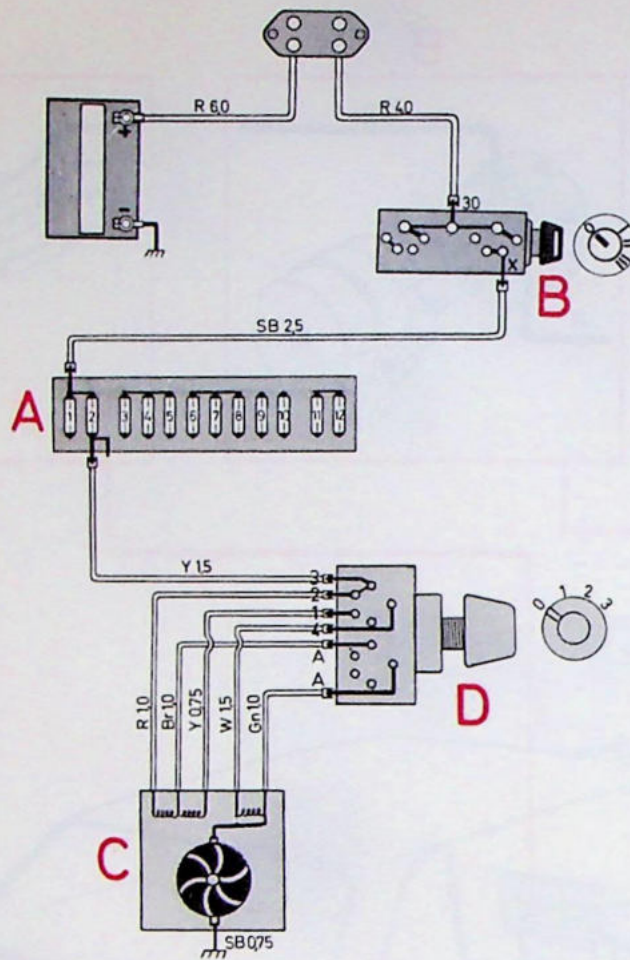

Snelheid 1

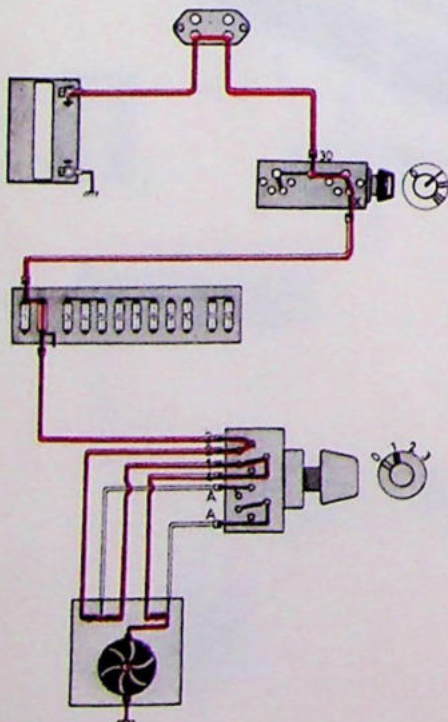

Snelheid 2

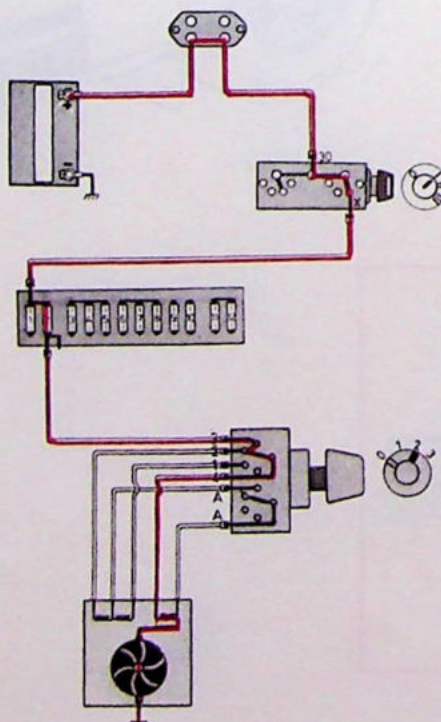

Snelheid 3

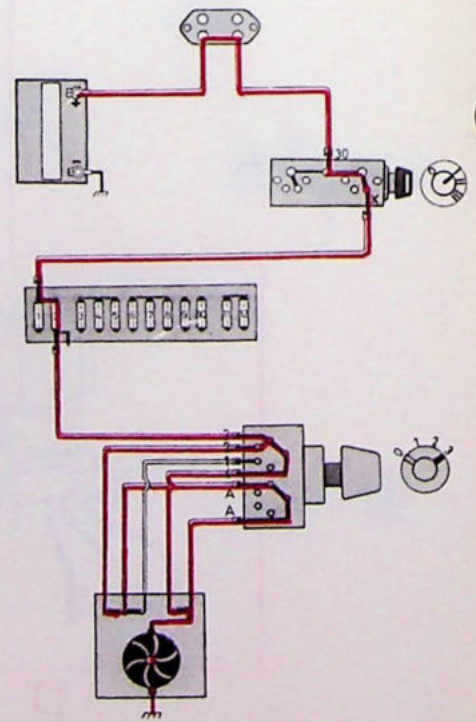

# Luchtaanjager gecombineerd verw.systeem

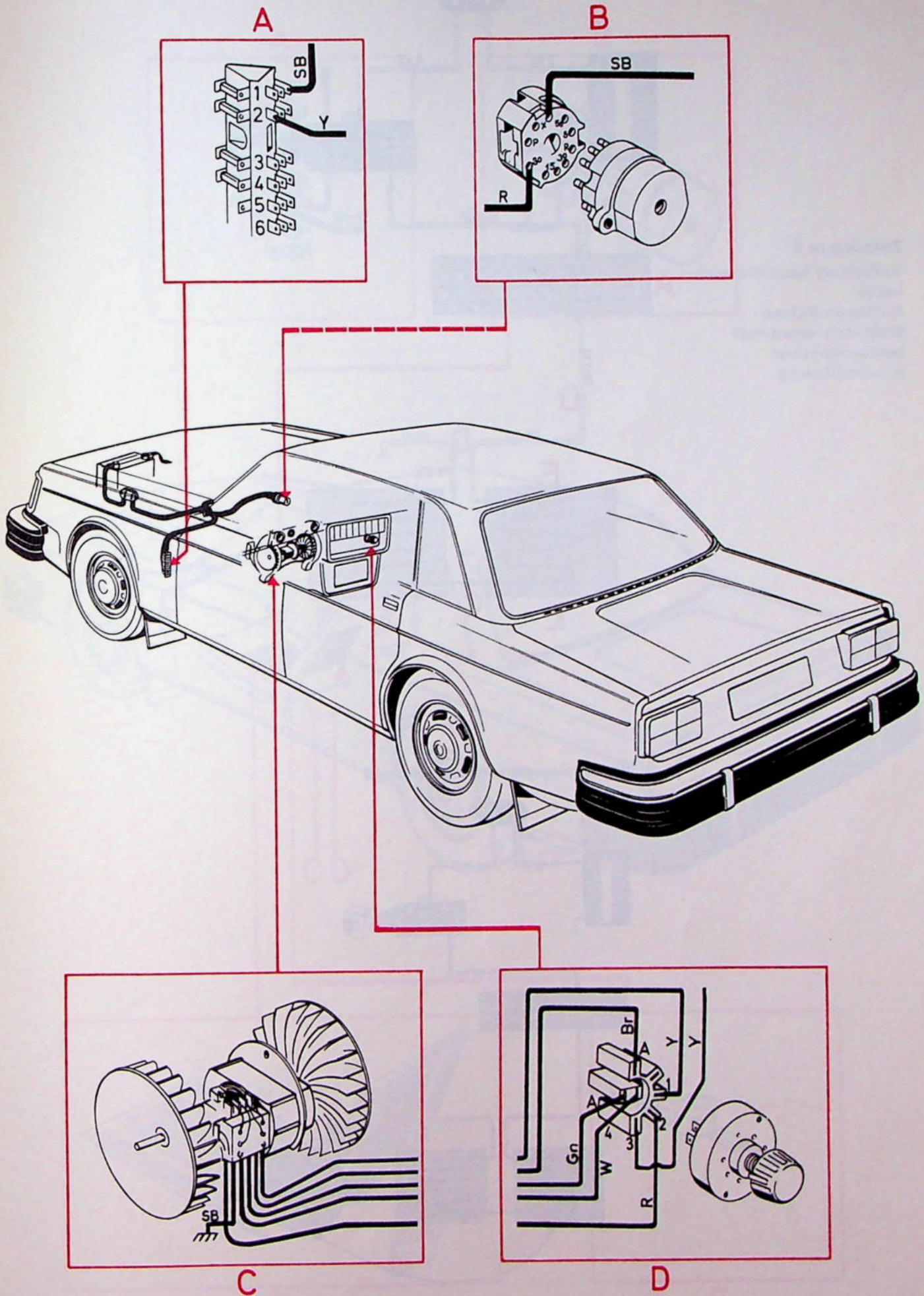

# Elektrisch verwarmde bestuurdersstoel

Zekering nr 4  
 Verlichting handschoenen-  
 kastje  
 Achteruitrijlichten  
 Elektrisch verwarmde  
 bestuurdersstoel  
 Air-conditioning

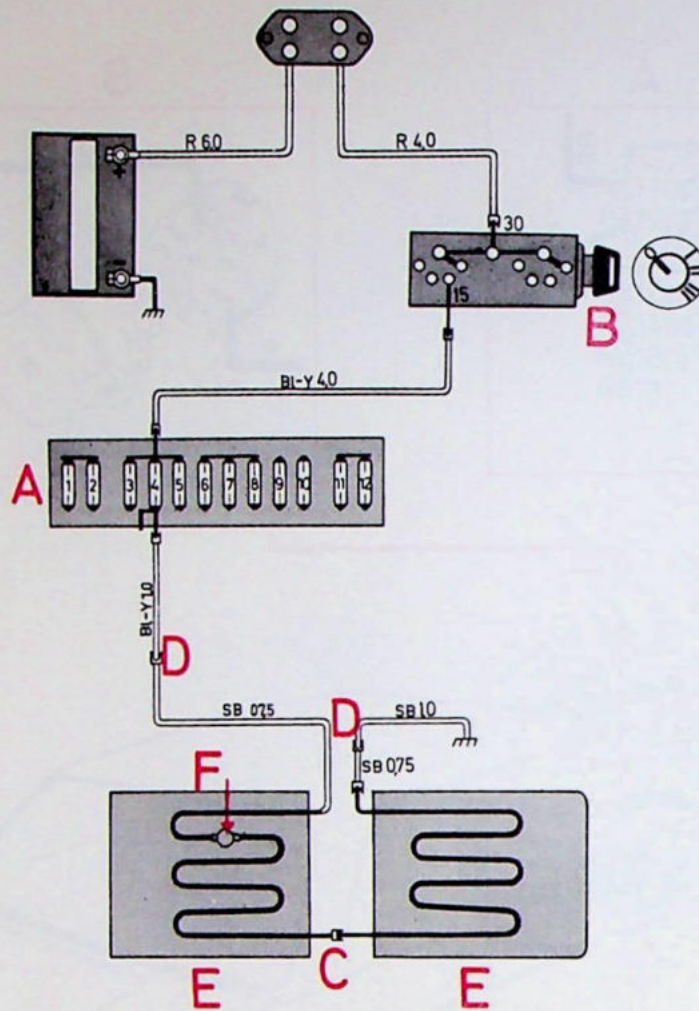

Verwarmingselement ingeschakeld

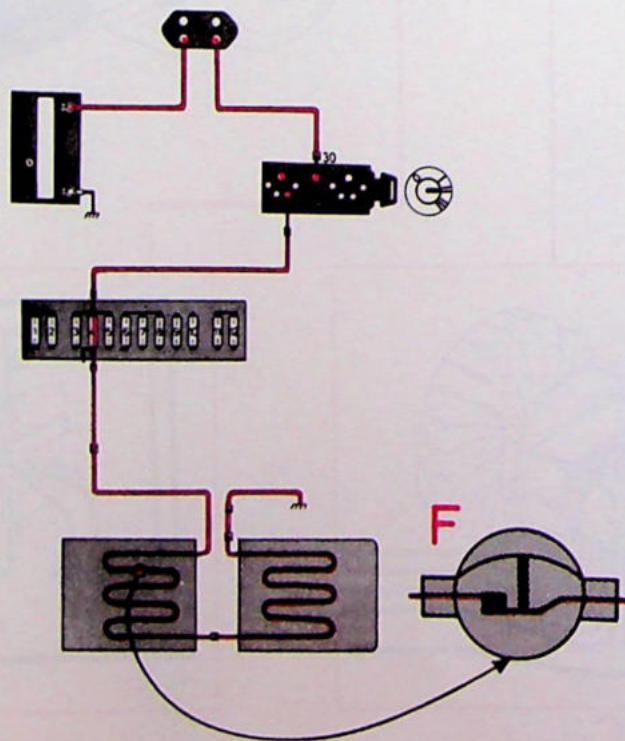

# Elektrisch verwarmde bestuurdersstoel

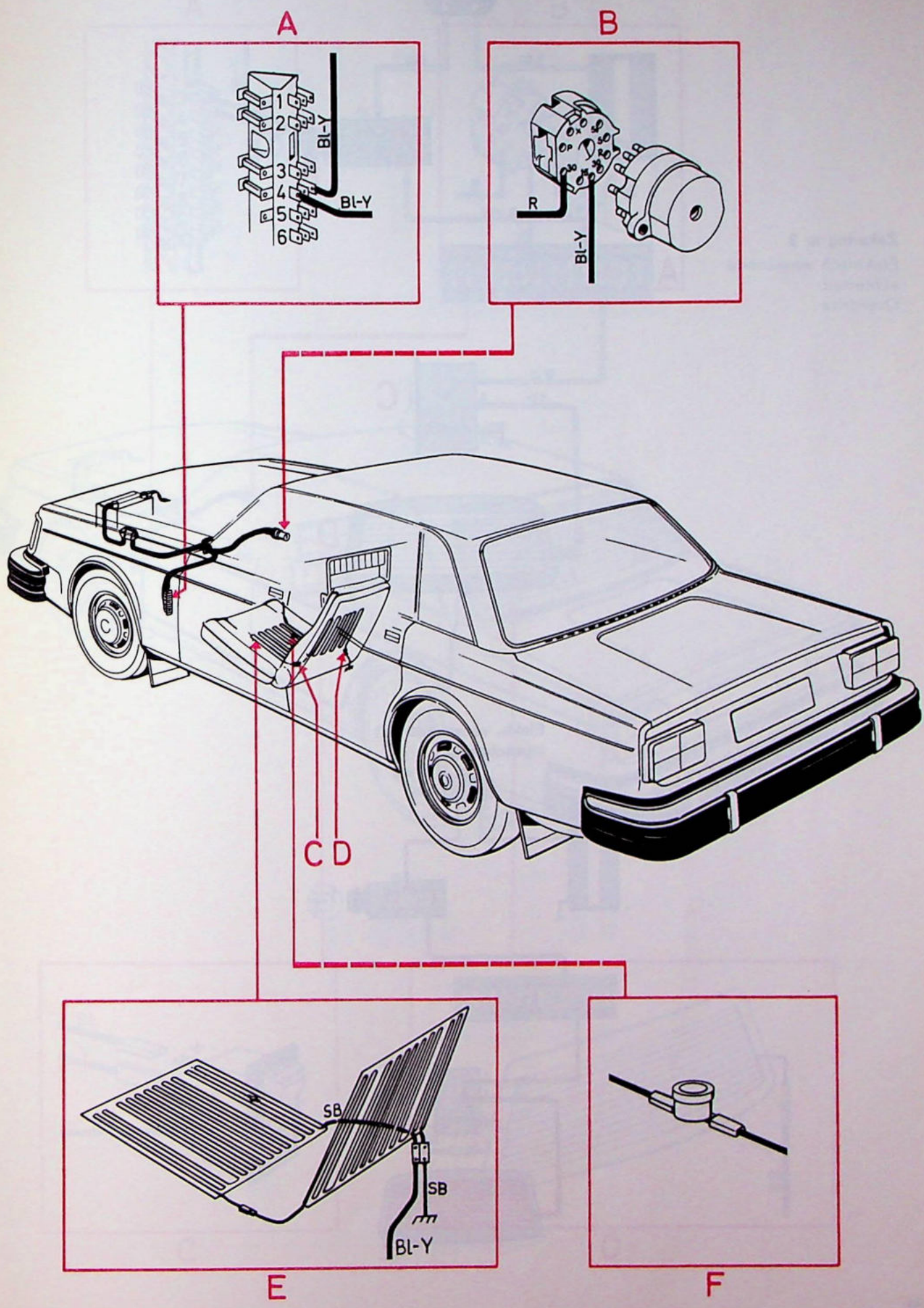



# Elektrisch verwarmde achterrait, 242-244

A

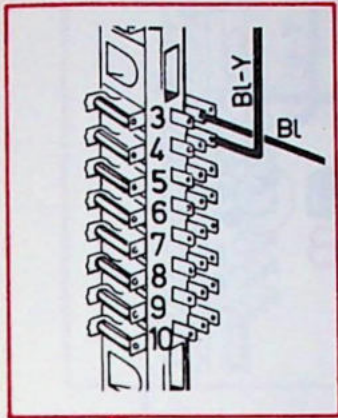

B

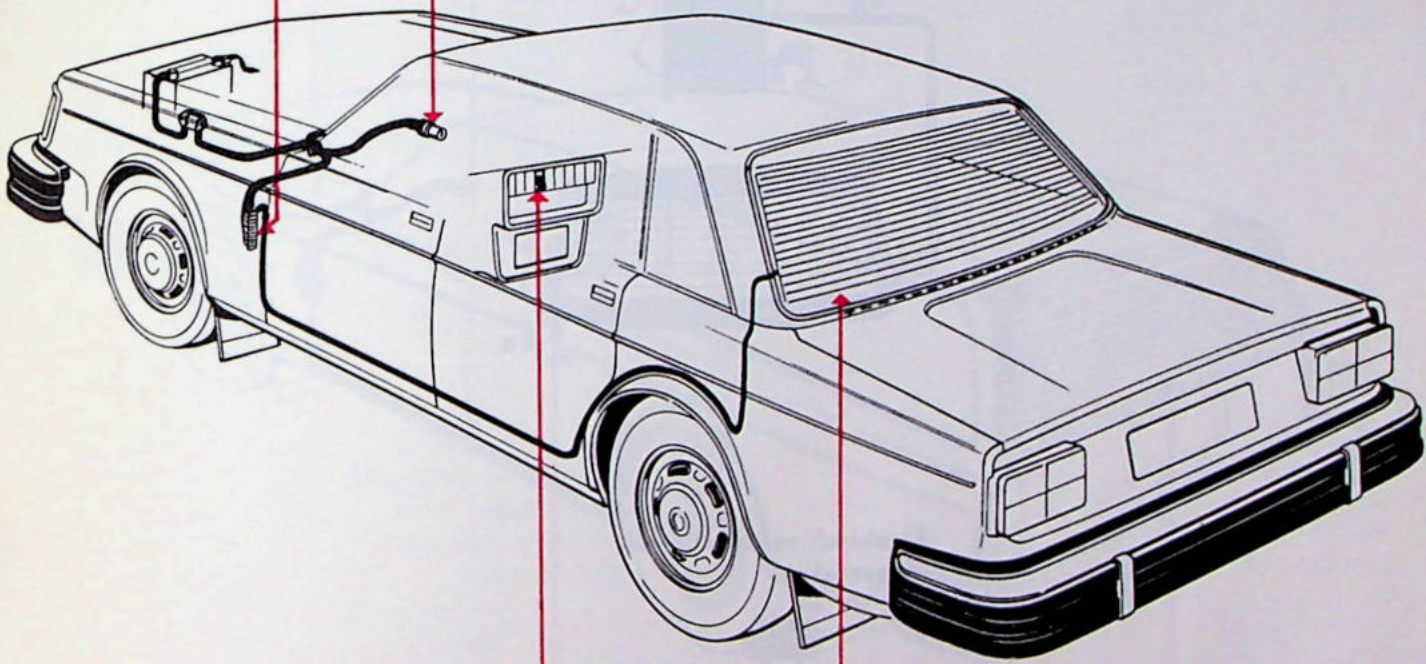
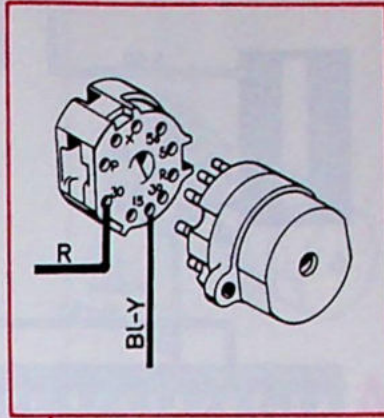

C

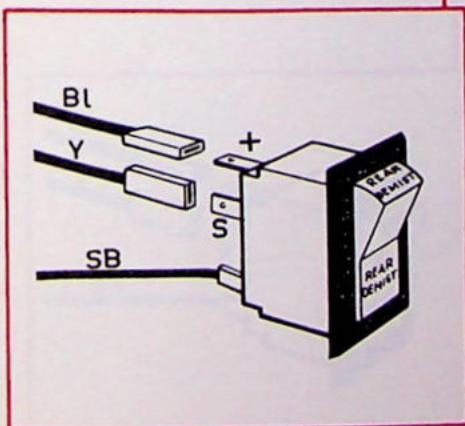

D

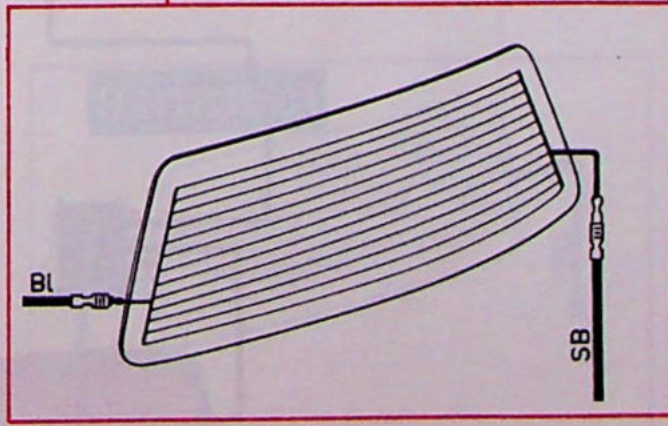

# Elektrisch verwarmde achterrait, 245

Zekering nr 3  
Elektrisch verwarmde  
achterrait  
Overdrive

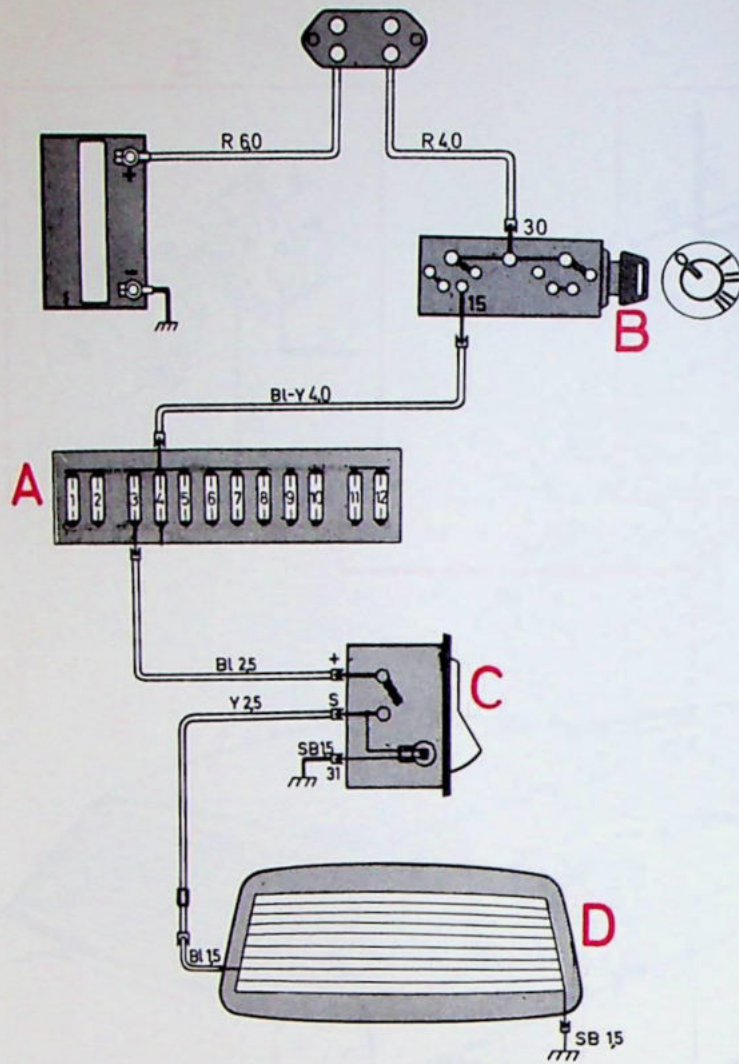

Elektrisch verwarmde rit  
ingeschakeld

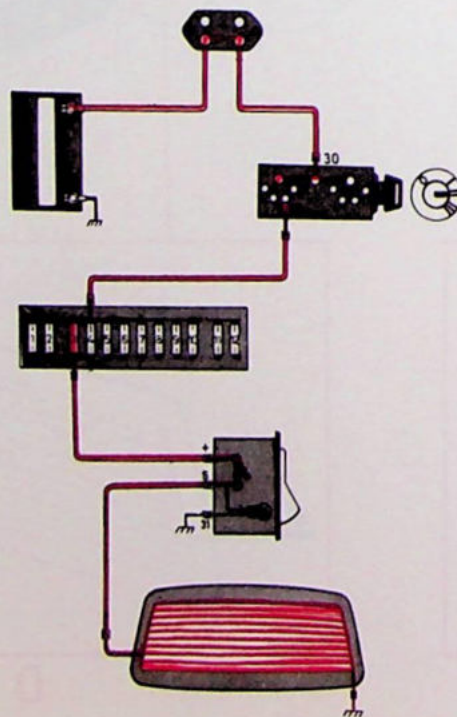

# Elektrisch verwarmde achterrait, 245

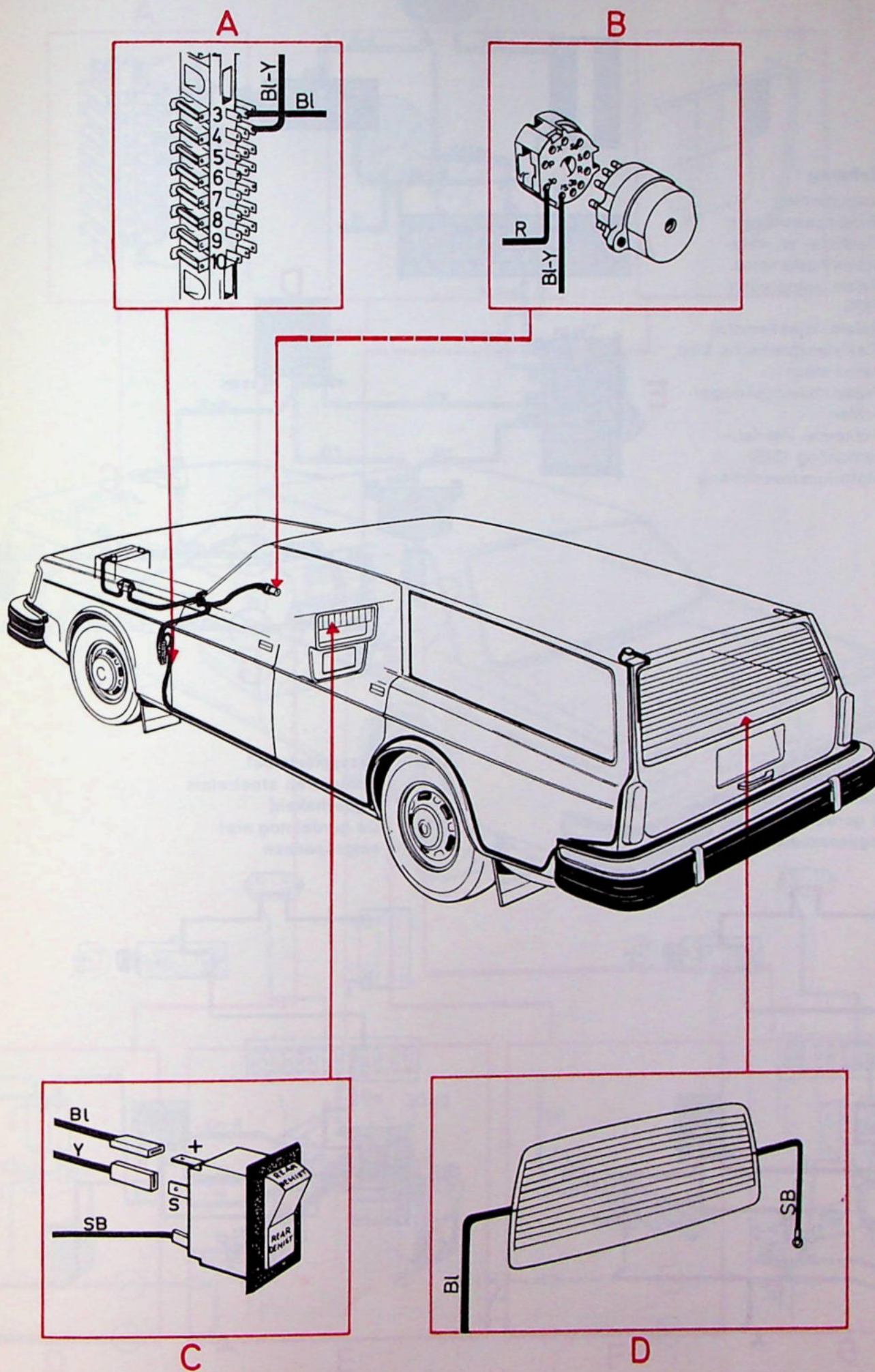

# Waarschuwingssysteem veiligheidsgordels

Nr Zekering

- 5 Instrumenten  
Richtingaanwijzers  
Controle- en waarschuwinglampjes  
Relais autogordels 1976  
Relais, injectiemotor  
Elektromagnetische klep, carburateur
- 6 Waarschuwingssnipperlichten  
Achterste interieurverlichting (245)  
Motorruimteverlichting

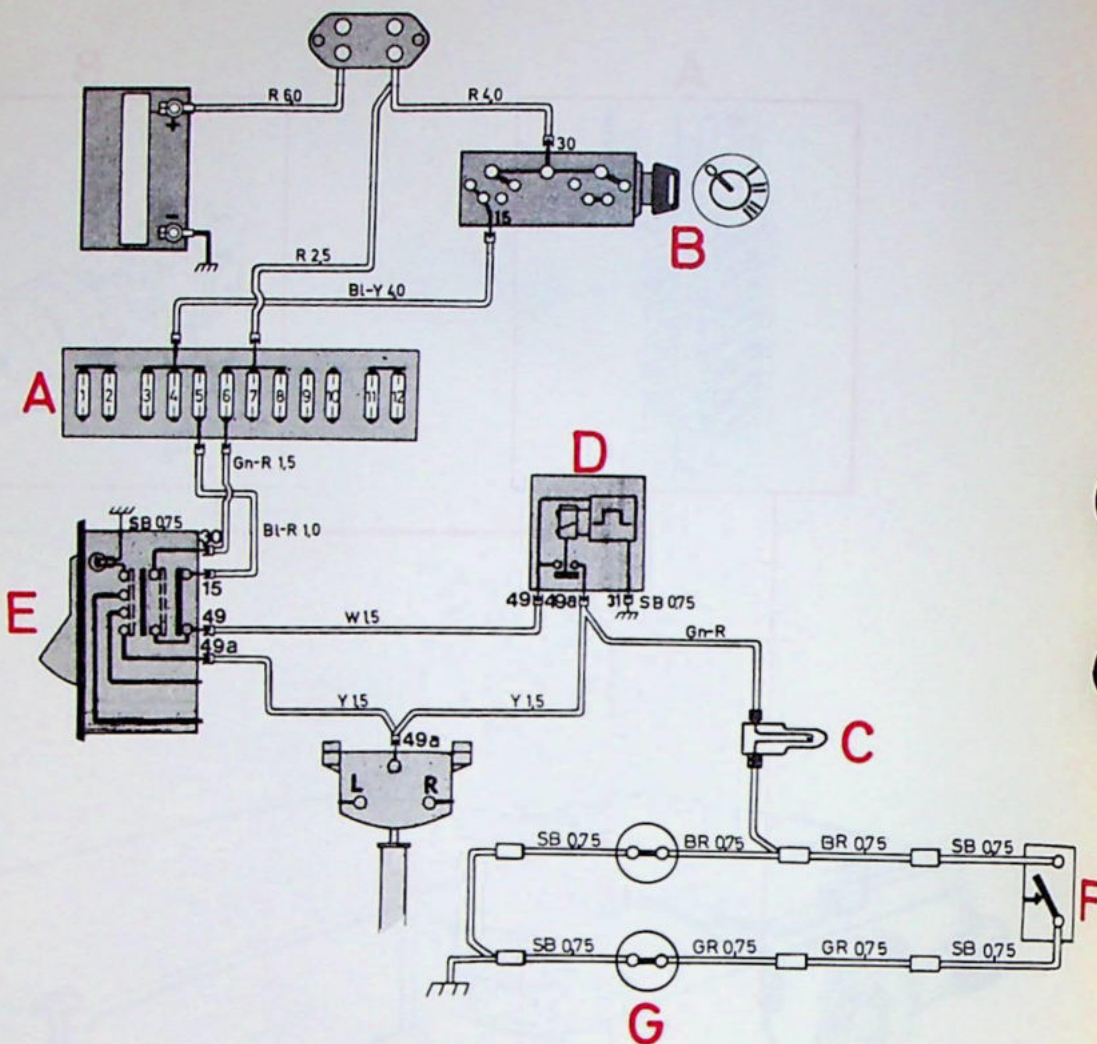

Bestuurdersstoel  
Contact ingeschakeld  
De gordel nog niet omgespannen

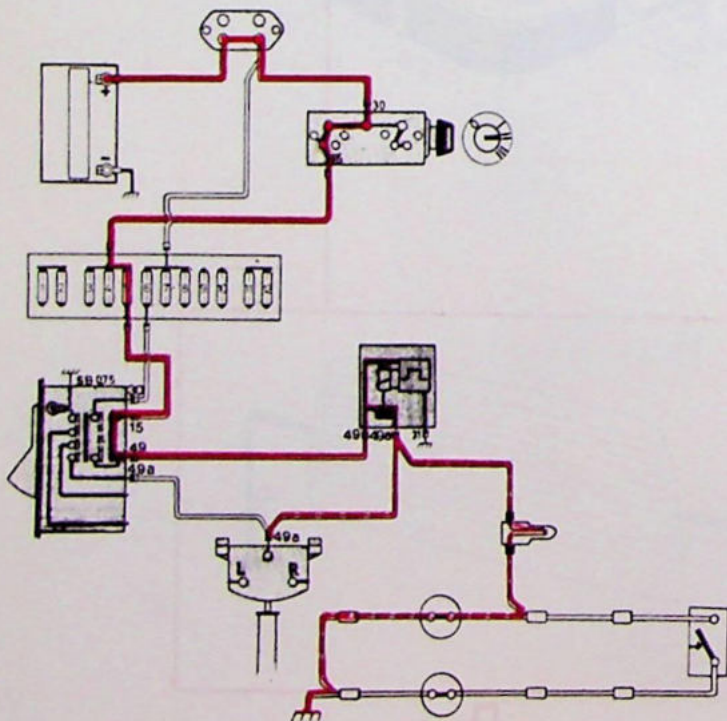

Passagiersstoel  
Contact en stoelrelais  
ingeschakeld  
De gordel nog niet omgespannen

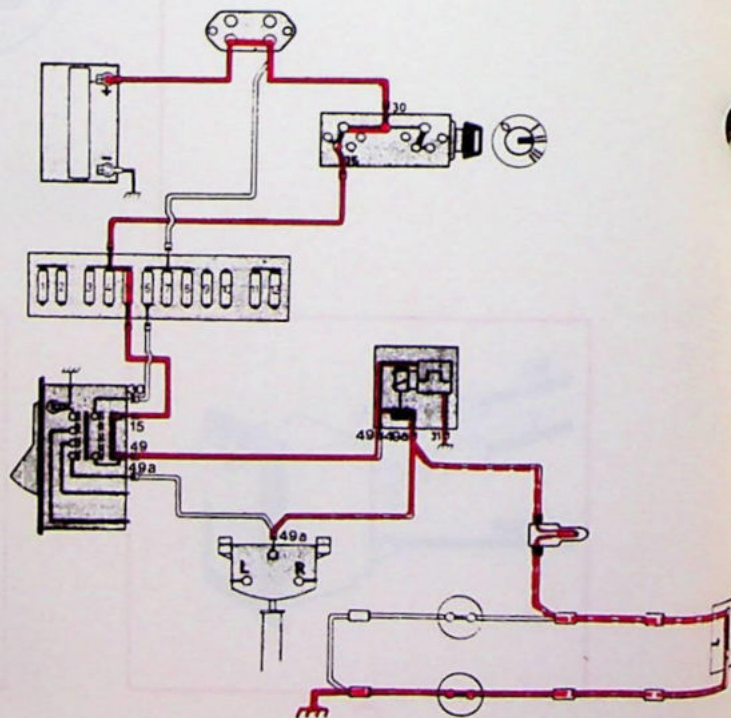

# Waarschuwingssysteem veiligheidsgordels

A

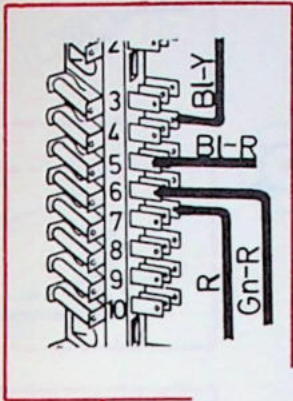

B

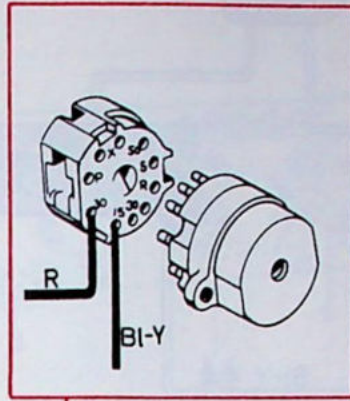

C

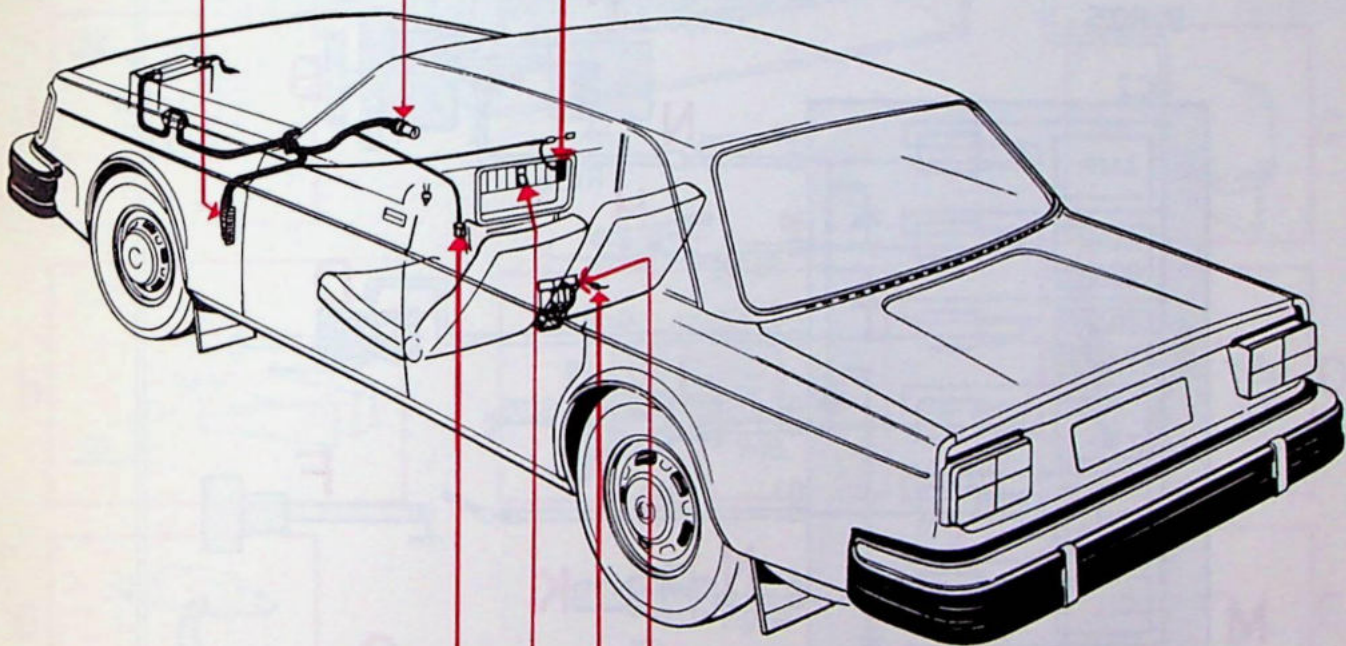
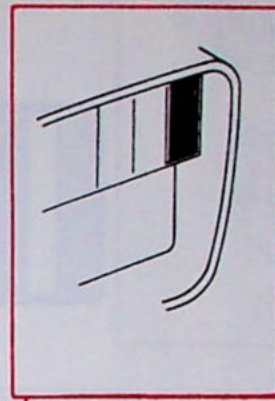

D

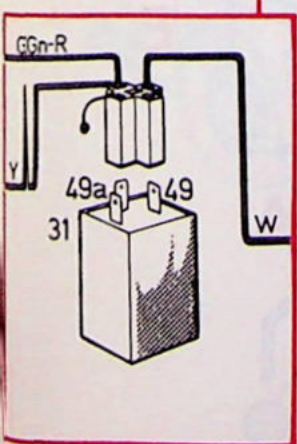

E

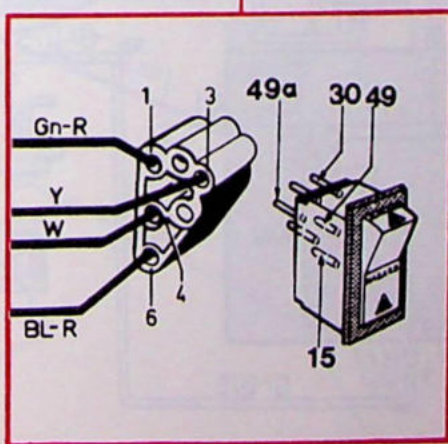

F

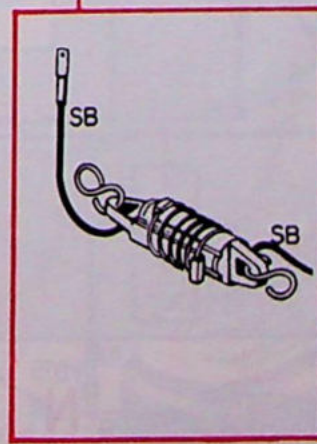

G

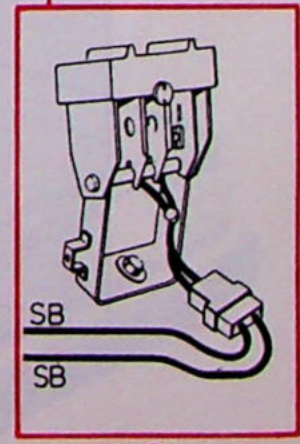

# Instrumentenpaneel

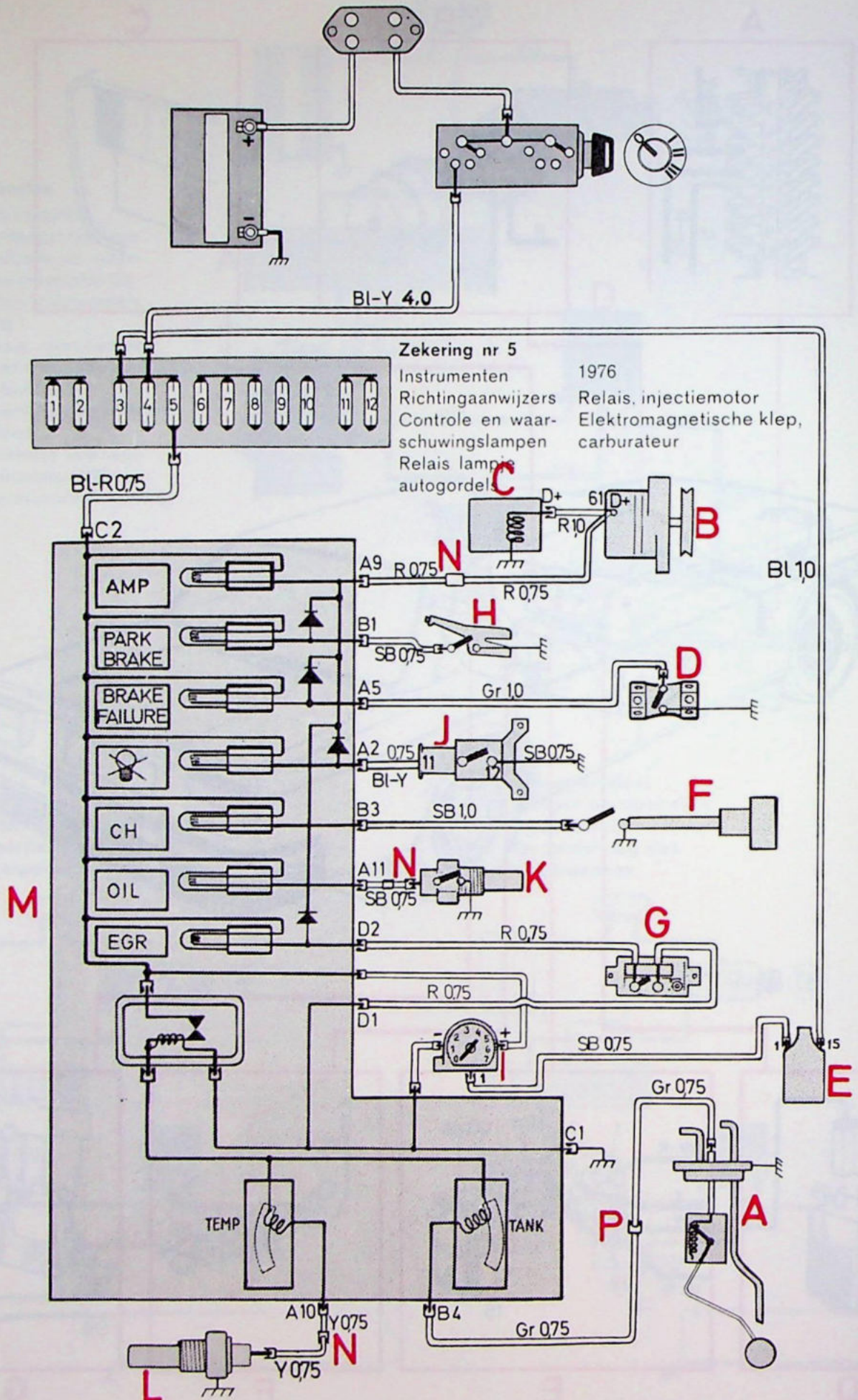

# Instrumentenpaneel

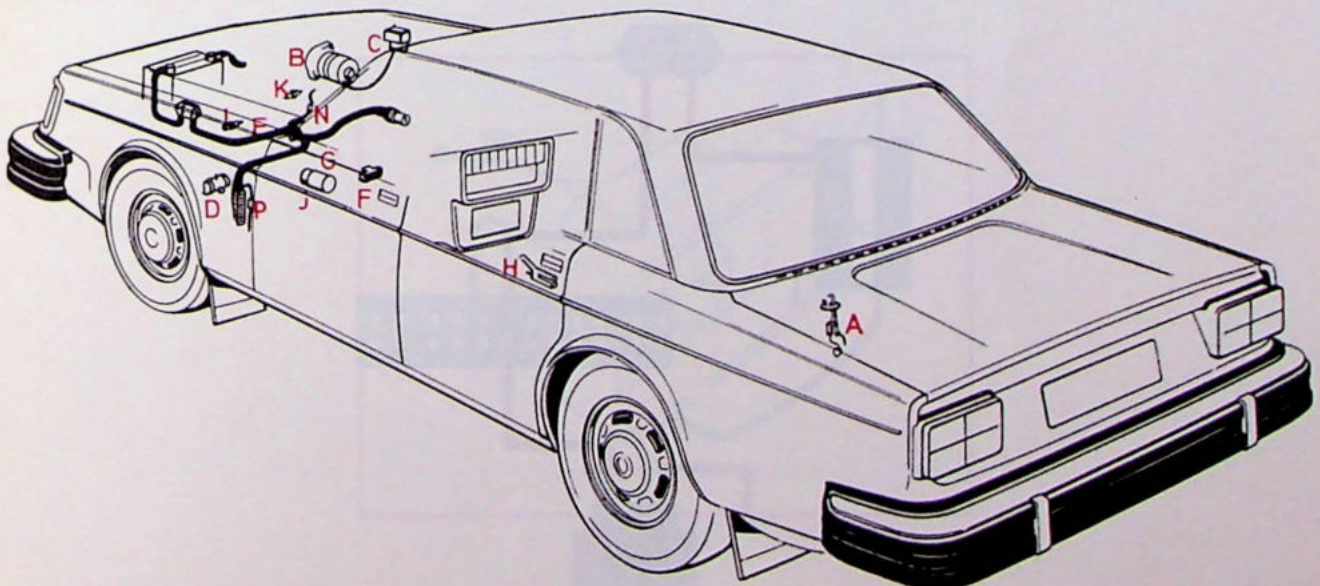
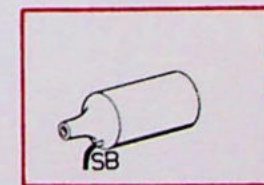
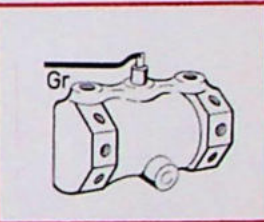
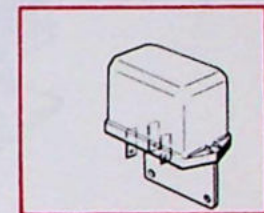
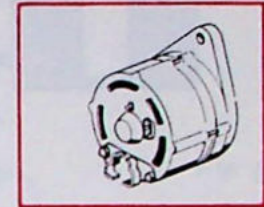
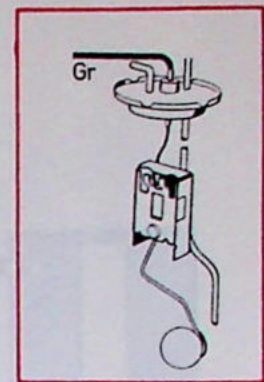
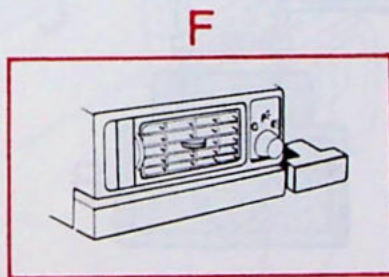
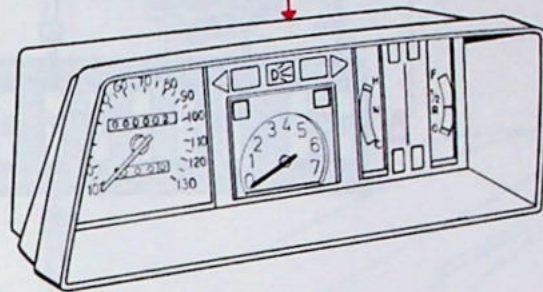
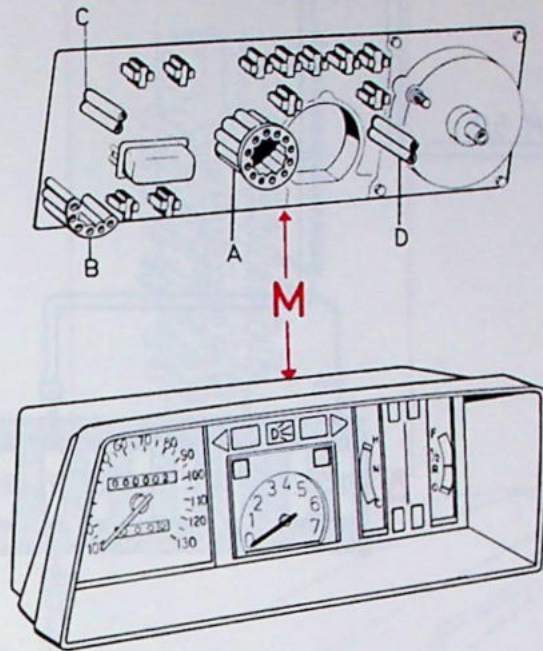
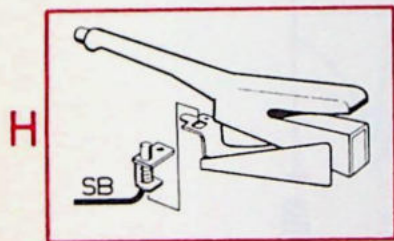
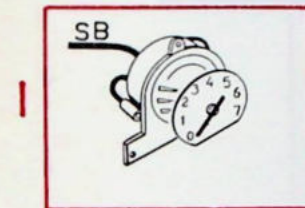
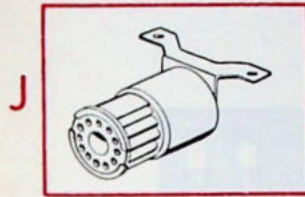
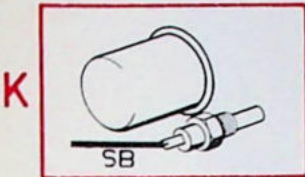
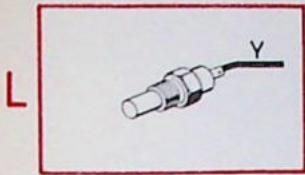

# Klokje

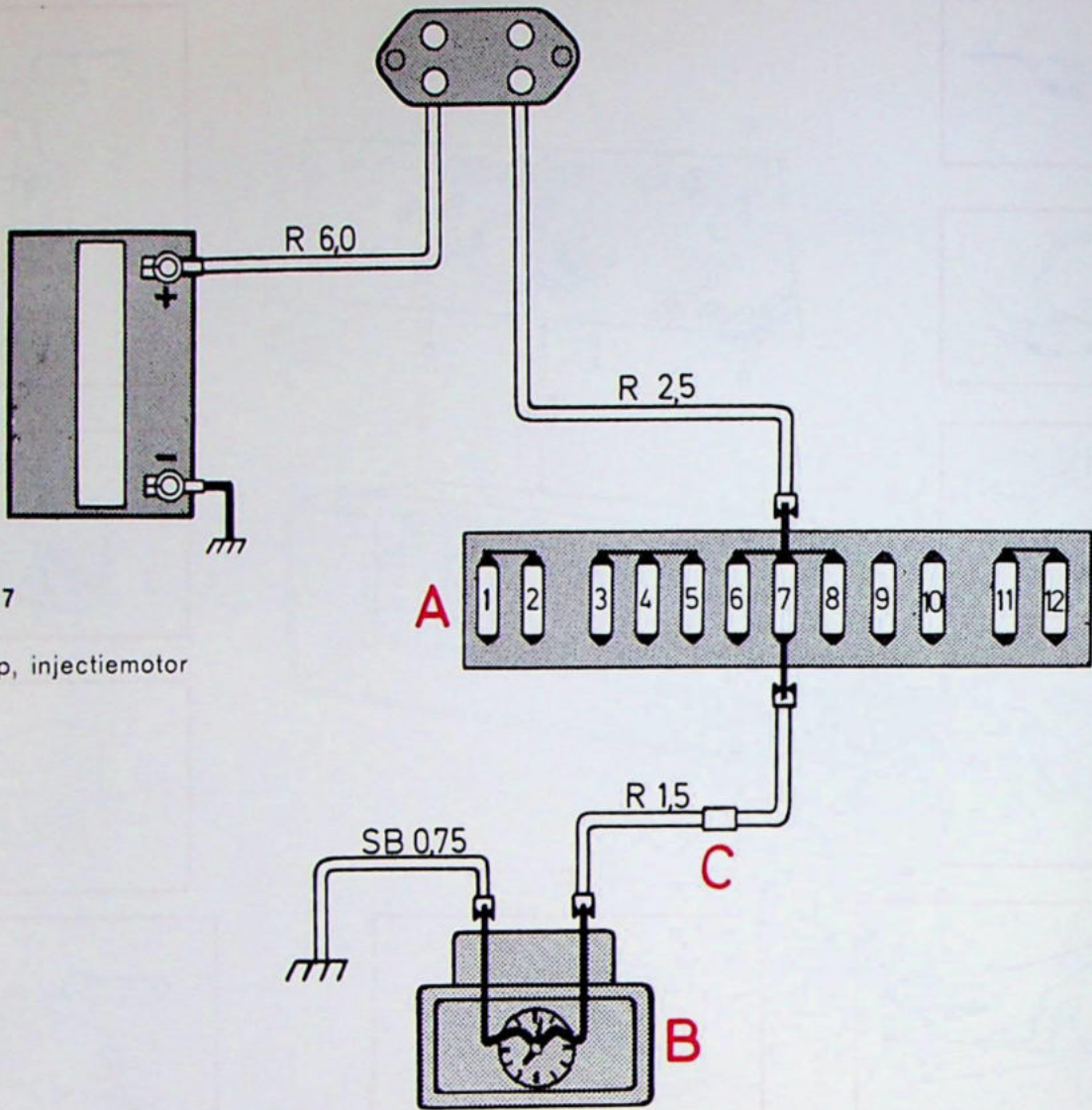

Zekering nr 7  
Klokje  
Benzinepomp, injectiemotor

## Klokje ingeschakeld

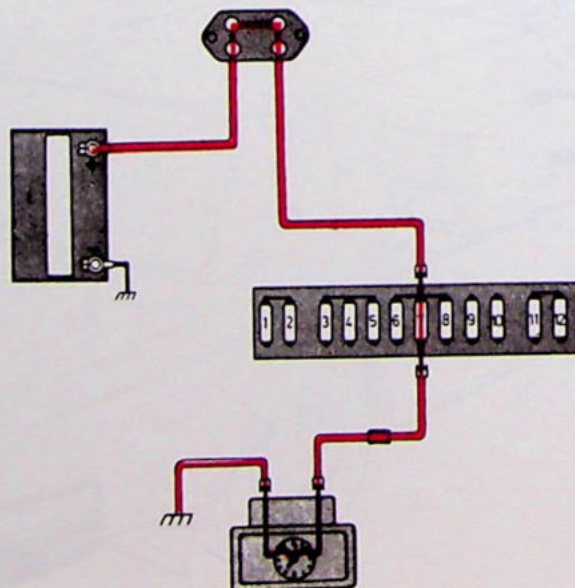

# Klokje

A

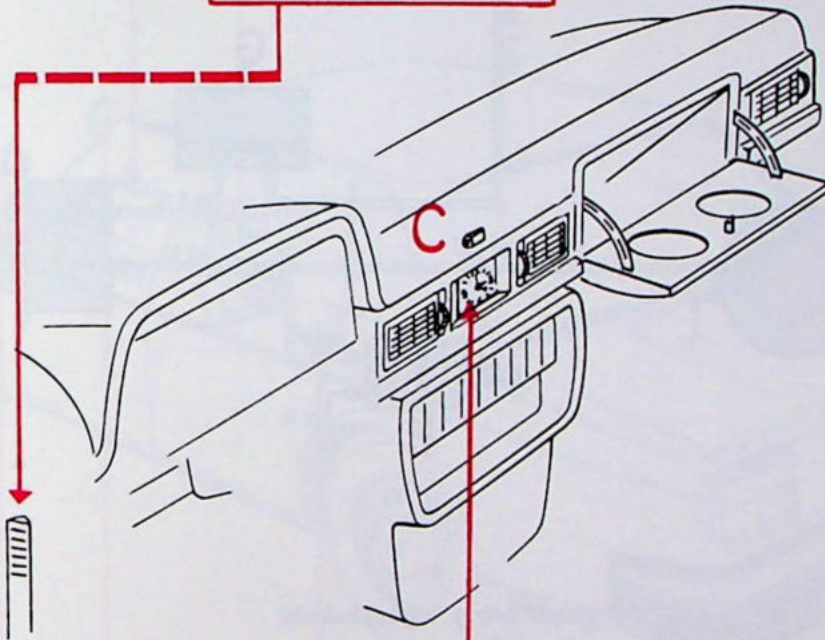
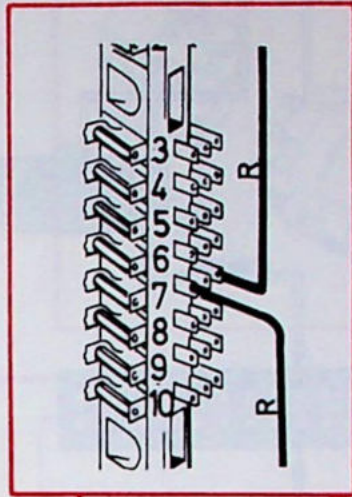

B

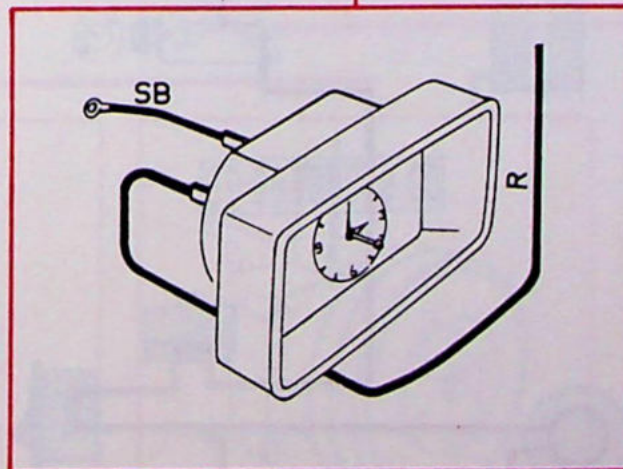

# Air-conditioning

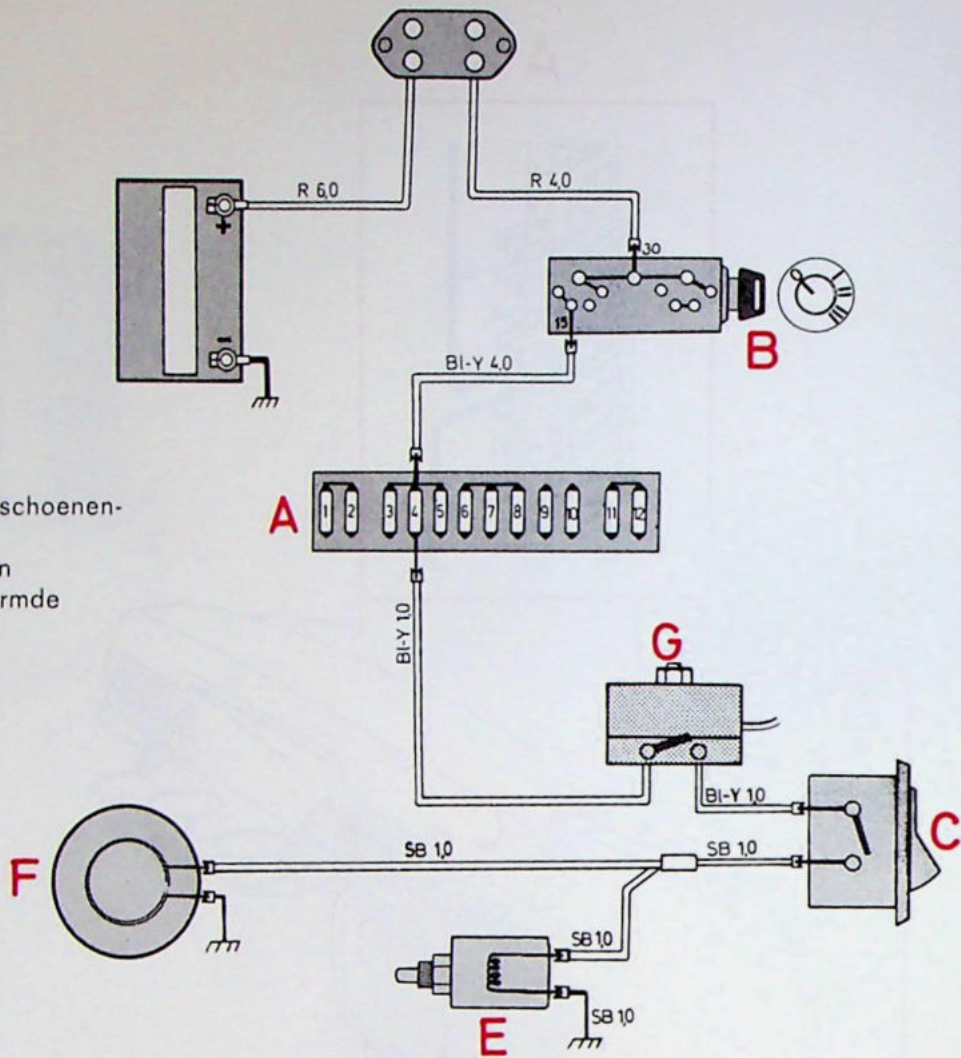

## Zekering nr 4

- Verlichting handschoenenkastje
- Achteruitrijlichten
- Elektrisch verwarmde bestuurdersstoel
- Air-conditioning

## Air-conditioning ingeschakeld

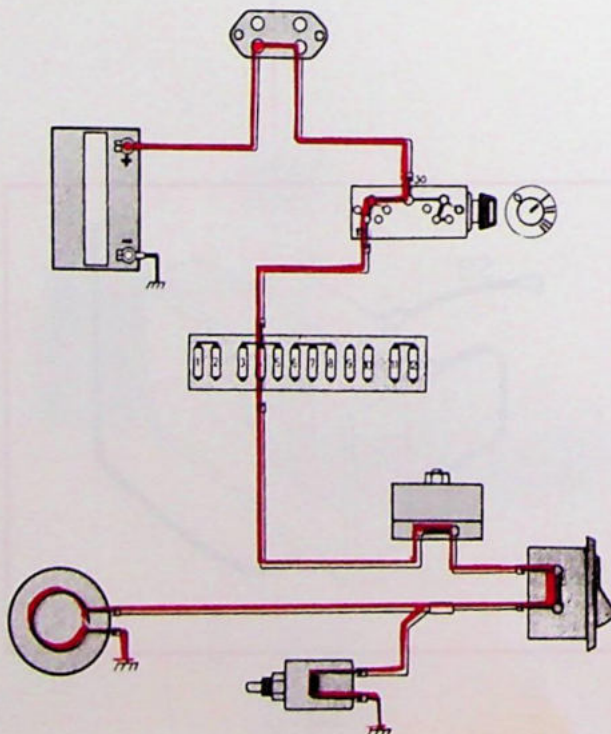

# Air-conditioning

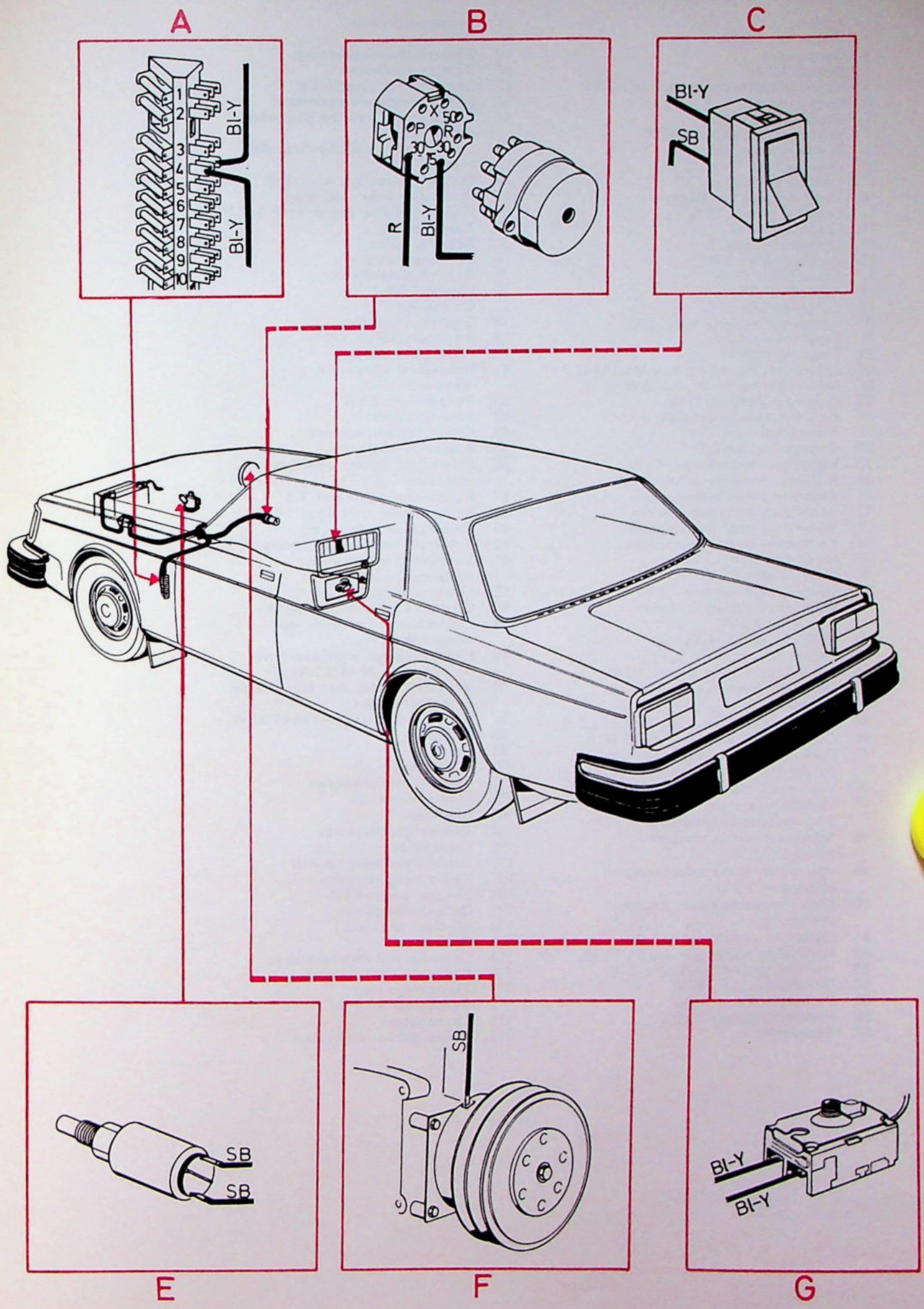

A

B

C

E

F

G