

# VOLVO

## Servicehandboek

Lokaliseren van storingen

Reparatie

Onderhoud

Hoofdgroep 3 (39)

Bedradingschema's

480

1986-1989

Juli 1989

TP 35496/2

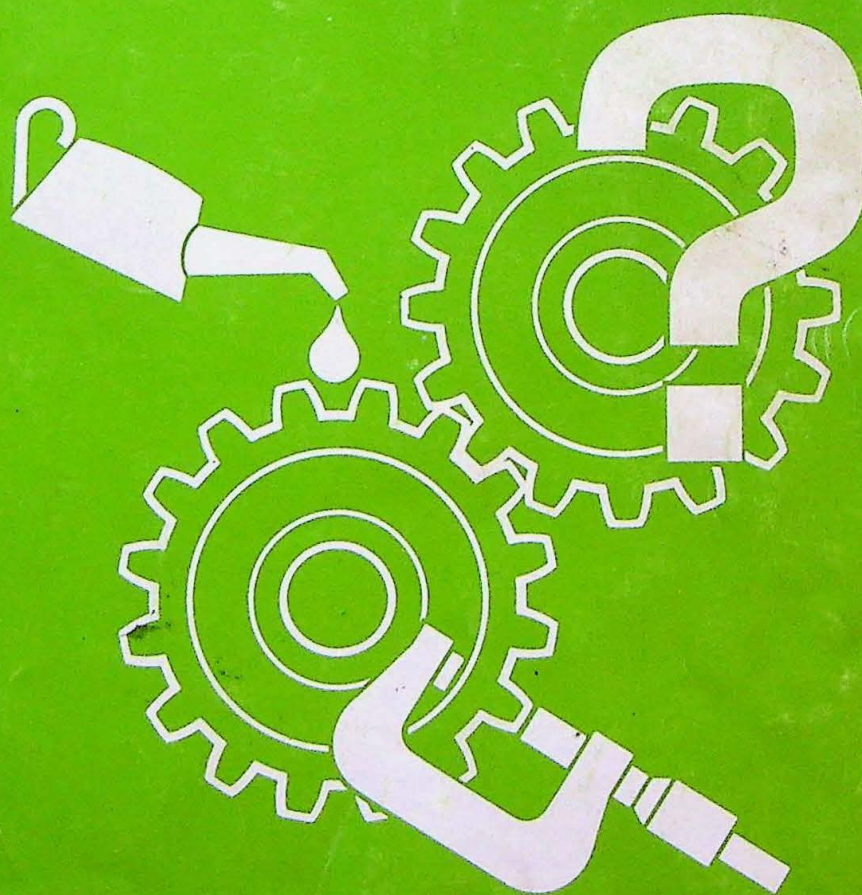

AUTODIVISIE VOLVO CAR B.V.

Volvo auto's worden verkocht in uitvoeringen die voor bepaalde landen zijn aangepast. Dit aanpassen berust o.a. op wettelijke voorschriften, belastinggrenzen en wensen van de betreffende afzetmarkt.

In dit servicehandboek kunnen daarom afbeeldingen en teksten voorkomen die geen betrekking hebben op de volvo-auto's in Uw land.

Inhoud	1	<b>Groep 38, instrumenten</b>	
Gebruiksaanwijzing voor de schema's	2	Instrument achterzijde	76
Gebruiksaanwijzing voor de schema's	3	Instrument met informatiecentrum	77
Centrale verdeeldoos — 1988	4	Instrument met informatiecentrum	78
Centrale verdeeldoos 1988 — (vanaf chassisnr. 529392)	5	Instrument met informatiecentrum	79
Overzicht relais	6	Toerenteller en snelheidsmeter	80
Overzicht zekeringen	7	Informatiecentrum, olieniveau, olietemperatuur	82
Overzicht kabelbomen	8	Informatiecentrum, brandstofmeter	84
Overzicht massapunten	9	Informatiecentrum, brandstofverbruik	86
Connectoren kabelboom A	10	Informatiecentrum, gemiddelde snelheid en buitentemperatuur	88
Connectoren kabelboom B F	11	Informatiecentrum, koelvloeistoftemperatuur	90
Connectoren kabelboom B FT	12	Controlelampen, remvloeistof, handrem, laadstroom en sproeivloeistof	92
Connectoren kabelboom C	13	Controlelamp "deur open" en zoemer verlichting	94
Connectoren kabelboom C	14	Controlelamp, veiligheidsgordels	96
Connectoren kabelboom C RHD	15	Consoleklok	98
Connectoren kabelboom C RHD	16	Accuvolt- en oliedrukmeter	100
Connectoren kabelboom C RHD	17		
Connectoren kabelboom D, E, K,	18	<b>Groep 59, anti-blokkeersysteem</b>	
Connectoren kabelboom F, G,	19	ABS systeem	102
Connectoren kabelboom H, J,	20		
Connectoren kabelboom L	21		
		<b>Groep 83, portieren, enz.</b>	
<b>Groep 23, brandstofsysteem</b>		Centrale vergrendeling	104
Brandstofinspuiting, B18 E	22	Elektrisch bedienbare zijruiten	106
Brandstofinspuiting, B18 F	24	Inbraakalarmsysteem en claxon	108
Brandstofinspuiting, B18 FT	26	Schuifdak	110
		<b>Groep 84, uitwendige onderdelen</b>	
<b>Groep 26, koelsysteem</b>		Achterraut- en spiegelverwarming	112
Hulpwaterpomp, B18 E en F	28	Elektrisch instelbare spiegels	114
Hulpwaterpomp, B18 FT	30		
		<b>Groep 85, interieur</b>	
<b>Groep 28, ontsteking</b>		Voorstoelverwarming	116
Contactschakelaar + automaat	32		
Elektronische ontsteking, B18 E motoren	34	<b>Groep 87, ventilatie en verwarming</b>	
Ontsteking en zuurstofsensor, B18 F motoren	36	Verwarming 4-standen	118
		Verwarming 5-standen (vanaf chassisnr. 513100)	120
<b>Groep 35, verlichting</b>		VEM inhoud	121
Verlichting vóór met dagrijlichten	38	Airconditioning	122
Grootlichtsignaal, verstralers, oprijlaanverlichting	40		
Gedimd-dimlicht, grootlicht GB	42	<b>Groep 89, diversen</b>	
Verlichting achter met lamp-defectcontrole	44	Radio	124
Mistlampen, Euro, GB	46		
Mistlampen, S, CH	48	<b>Principeschema 1988-1989</b>	
Mistlampen, D, A	50	1	126
Mistachterlichten, Euro	52	2	127
Mistlampen voor en achter NL	54	3	128
Mistlampen voor en achter N en SF	56	4	129
Achteruitrijlichten	58	5	130
Instrumentenverlichting	60	6	131
Binnenverlichting + sleutelgatverlichting	62	7	132
Verlichting handschoenenkastje, motor, aansteker	64	9 E	133
		10 F	134
<b>Groep 36, overige elektrische uitrusting</b>		11 FT	135
Richtingaanwijzers	66	12 ABS	136
Ruitwissers voorruit	68		
Koplamp- en ruitesproeiers	70	Componentenlijst op componentnummer	137
Ruitwisser en sproeier achterraut	72	Componentenlijst op componentnummer	138
Koplampmotoren	74	Componentenlijst op componentnummer	139
		Componentenlijst alfabetisch	140
		Componentenlijst alfabetisch	141
		Componentenlijst alfabetisch	142
		Alfabetisch register	143

Bestelnummer: TP 35496/2

Wijzigingsrechten voorbehouden

# Gebruiksaanwijzing voor de schema's

Zoek in de inhoudsopgave het gedeelte van de elektrische installatie op, dat u nodig hebt.

**Linkerpagina:** hier ziet men de inwendige bedrading van de componenten en de bedrading tussen de componenten onderling.

De naam van het circuit als vermeld in de inhoudsopgave.

Een niet gespecificeerde connector.  
Voor de aansluitgegevens zie Instrument, pagina's 77, 78 en 79.

**Meerpolige connectoren:**  
Een verbinding tussen 2 draadbomen, in dit geval de consoledraadboom d en de dashboarddraadboom c. De verbindingspen is nr. 4.

A22: dit geeft een aansluiting op het component aan, in dit geval: connector A, pen 22 van de CEM.

## Controlelamp, veiligheidsgordels

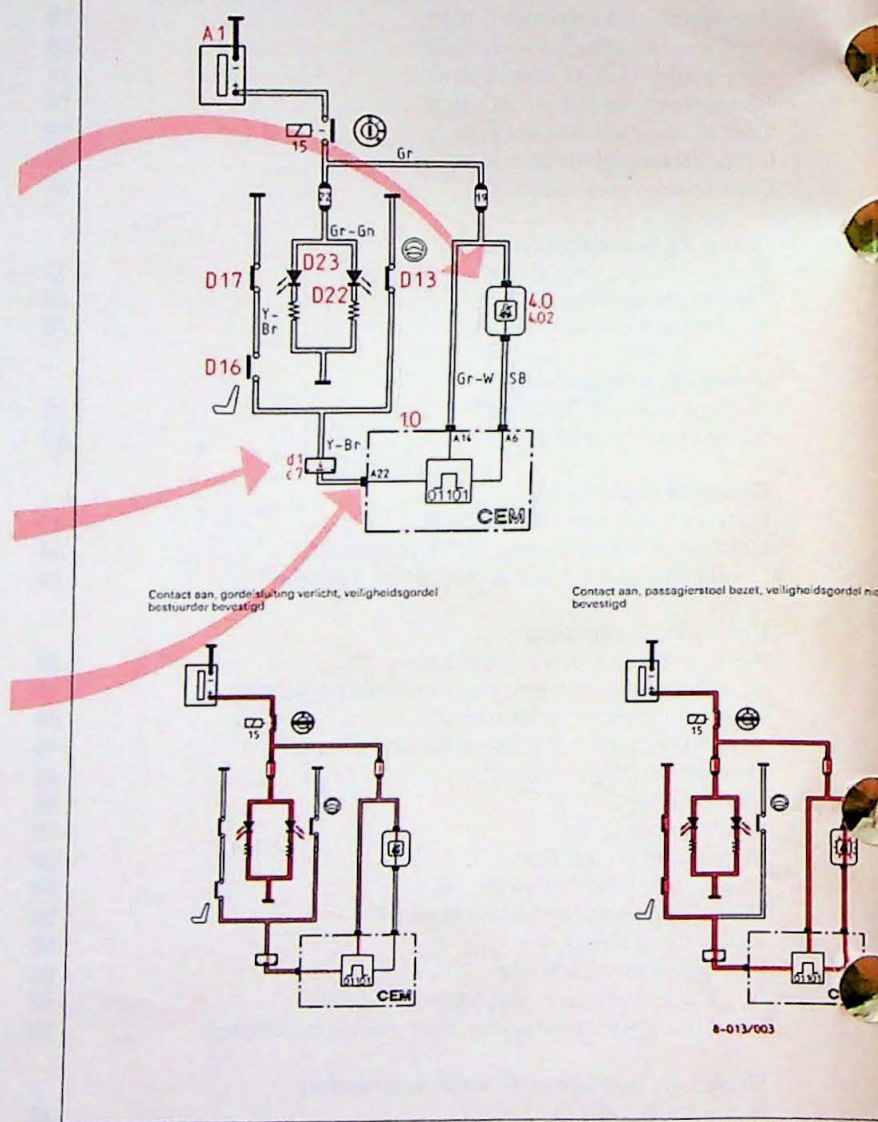

## Bedrading kleurencodes

SB	zwart	SB-R	zwart/rood
W	wit	SB-BI	zwart/blauw
GR	grijs	SB-Br	zwart/bruin
R	rood	W-SB	wit/zwart
Or	oranje	W-R	wit/rood
Y	geel	W-Gn	wit/groen
Gn	groen	W-BI	wit/blauw
BI	blauw	W-Br	wit/bruin
L	Lila	Gn-Y	groen/geel
P	rose	BI-R	blauw/rood
Br	bruin	BI-Y	blauw/geel

Kleuren van de bedrading en referentienummers van de componenten zijn alleen in het grotere schema getoond. In de kleine **schema's** zien men de verschillende werkstanden met...

- Stroom —————
- Spanning (geen stroom) - - - - -
- Verbinding met massa —————

Opmerking: indien niet gespecificeerd, is de draadkleur van een **massa** verbinding altijd bruin.

# Gebruiksaanwijzing voor de schema's

Rechter pagina: hier ziet men de plaatsing van de verschillende componenten in de auto.

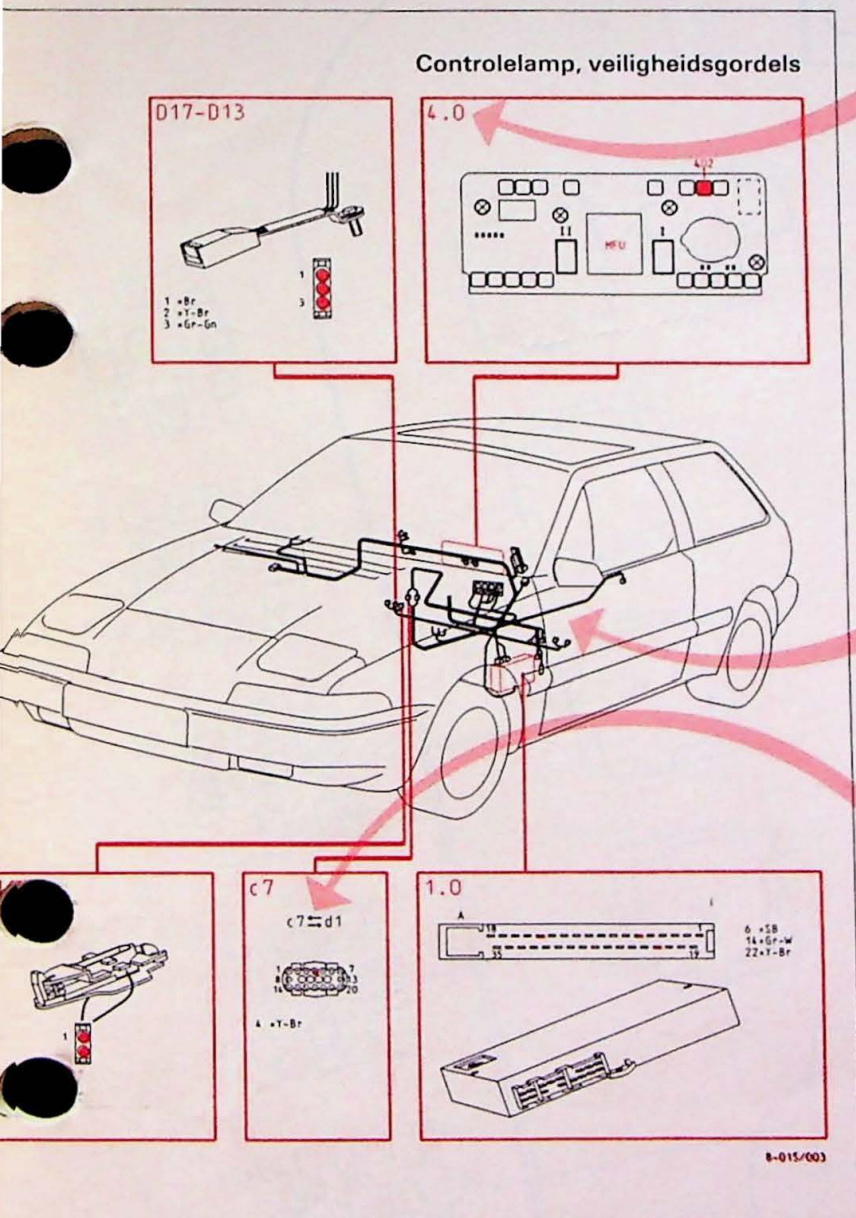

Dit is het referentienummer van het component in het Principeschema. Men vindt een complete lijst van componentbenamingen op de pagina's 137 en 138.

Hier ziet men de ligging van de bedrading in de auto en tevens de plaats waar de bedrading is aangesloten op de betreffende componenten.

**Meerpolige connector:** (achterkant van connector getoond): hier ziet men welke pennen worden gebruikt voor de betreffende aansluitingen in het schema op de linker pagina.

**Nationaliteits-letters:** denk eraan dat, wanneer een auto van een buitenlandse bezoeker gerepareerd moet worden, er **verschillen** in de elektrische circuits aanwezig kunnen zijn.

Bepaalde nationaliteits-letters (geplakt op de achterkant van auto's buiten eigen land) zijn gebruikt om zulke verschillen aan te geven, bijvoorbeeld: **Mislampen, D en A.**

## Afkortingen gebruikt in de schema's

E/F Injectiesysteem zonder/met katalysator  
 FT Injectiesysteem Turbo  
 RHD Right Hand Drive  
 CEM Centrale Elektrische Module  
 VEM Verwarming Elektrische Module  
 ECU Injectie regeleenheid  
 ABS Anti Blokkeer Systeem  
 MFU Multi Functionele Unit

A	Oostenrijk	I	Italië
B	België	N	Noorwegen
CH	Zwitserland	NL	Nederland
D	Duitsland	P	Portugal
DK	Denemarken	S	Zweden
E	Spanje	SF	Finland
F	Frankrijk		
GB	Groot Brittanië (Ierland inbegrepen)		

# Centrale verdeeldoos tot 1988

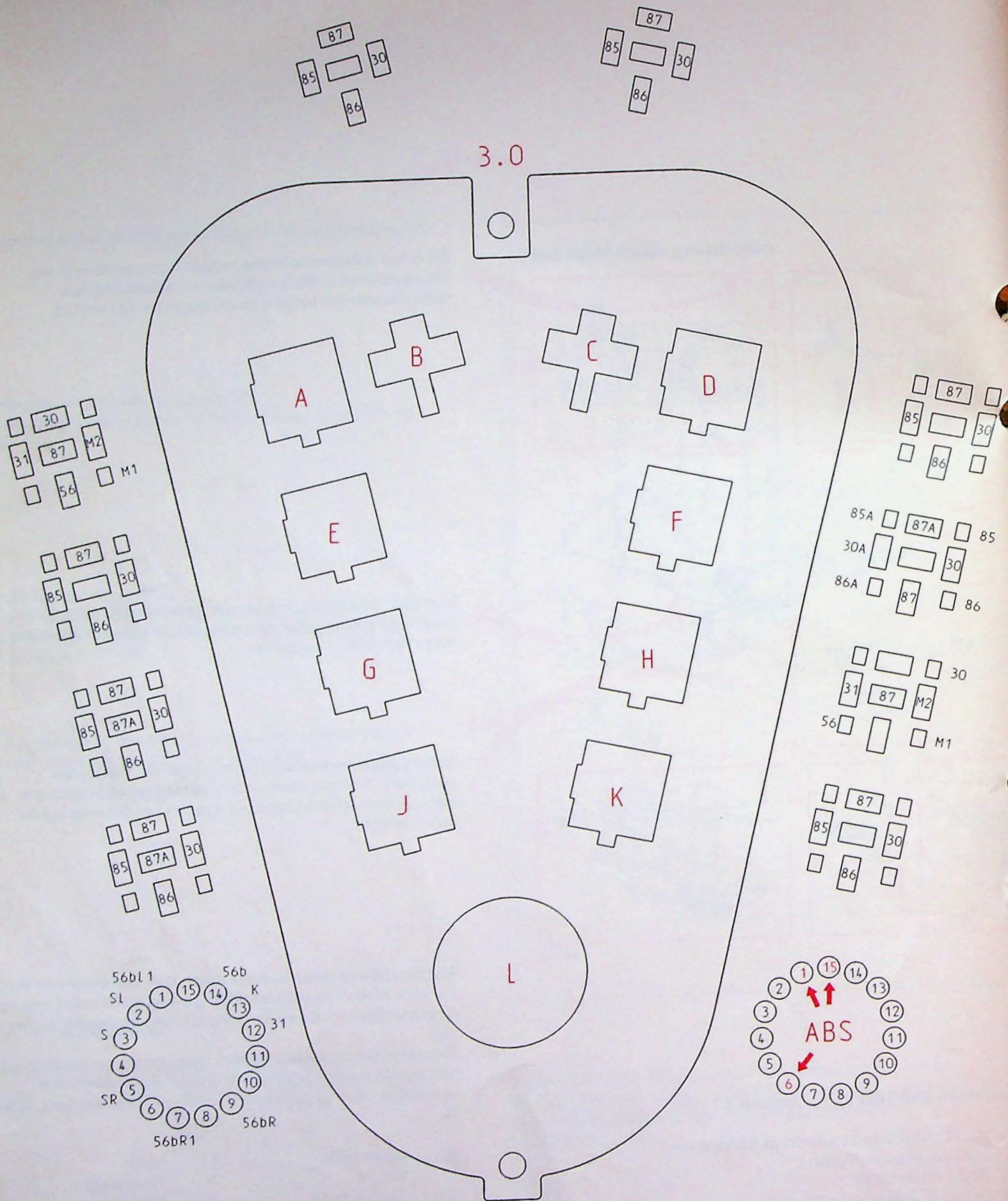

8-015/074A

# Centrale verdeeldoos vanaf 1988

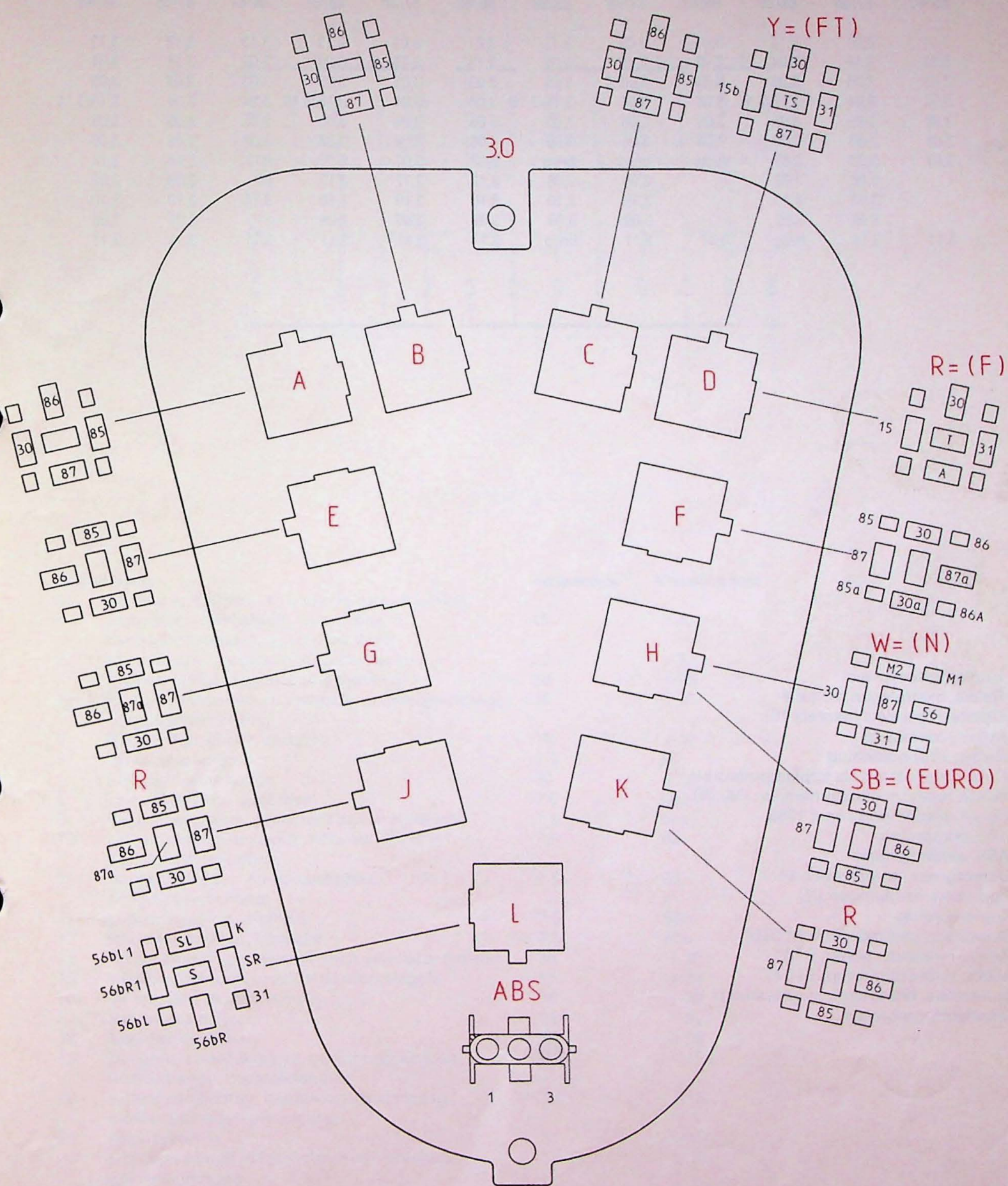

# Overzicht relais

	NL			EURO			N			GB		
	86/87	87/88	88/89	86/87	87/88	88/89	86/87	87/88	88/89	86/87	87/88	88/89
A	3,01	3,01	3,13	3,01	3,01	3,13	3,01	3,01	3,13	3,13	3,13	3,13
B	3,02	3,15	3,04	3,02	3,15	3,04	3,15	3,15	3,04	3,02	3,15	3,04
C	3,03	3,03	3,03	3,03	3,03	3,03	3,03	3,03	3,03	3,03	3,03	3,03
D	3,04	3,04	3,15/3,16	3,04	3,04	3,15/3,16	3,04	3,04	3,15/3,16	3,04	3,04	3,15/3,16
E	3,05	3,05	3,05	3,05	3,05	3,05	3,05	3,05	3,05	3,05	3,05	3,05
F	3,06	3,06	3,06	3,06	3,06	3,06	3,06	3,06	3,06	3,06	3,06	3,06
G	3,07	3,07	3,07	brug	brug	brug	3,07	3,07	3,07	B12	3,14	3,14
H	-	3,08	3,08	-	3,08	3,08	3,12	3,12	3,12	B2	3,08	3,08
J	-	3,10	3,10	-	3,10	3,10	3,10	3,10	3,10	3,14	3,10	3,10
K	-	3,09	3,09	-	3,09	3,09	3,09	3,09	3,09	-	3,09	3,09
L	3,11	3,11	brug	3,11	3,11	brug	3,11	3,11	3,11	3,11	3,11	3,11

- 3.01 Koplamp sperrelais
- 3.02 Relais, mistlampen tot 1988
- 3.03 Ontstekingsrelais (contact 15)
- 3.04 Relais, contact 75
- 3.05 Relais, airconditioning
- 3.06 Dubbelwerkendrelais koplampmotoren
- 3.07 Wisselrelais, mistachterlampen (NL, N)
- 3.08 Relais mistlampen vanaf 1988
- 3.09 ABS pomprelais
- 3.10 ABS voedingsrelais
- 3.11 Defectgever, gloeilampen voor
- 3.12 Sperrelais mistlampen (N)
- 3.13 Koplamprelais
- 3.14 Sperrelais, gedimd-dimlicht (GB)
- 3.15 Relais, hulpwaterpomp, B18 F
- 3.16 Relais, hulpwaterpomp, B18 FT
- B2 Stuurrelais, brandstofinspuitsysteem
- B12 Brandstofpomprelais

# Overzicht zekeringen

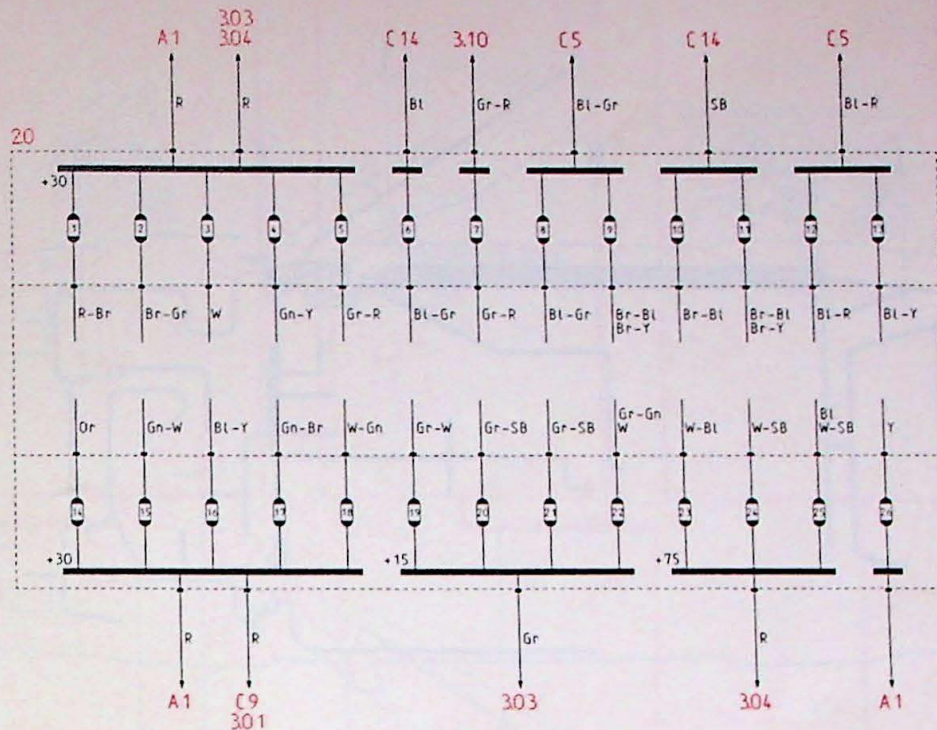

8-011/098

## Zekeringen

Zekeringen	Ampèrage	Voeding van
1 Aansteker, binnen- en kofferruimteverlichting motorruimteverlichting, verlichting handschoenenkast, radio, klok, MFU	15	+ 30
2 Mistlampen, grootlichtsignaalsysteem	20	+ 30
3 Kachelventilator (maximum snelheid)	30	+ 30
4 Koplampmotoren, centrale deurvergrendeling, sleutelgatverlichting	30	+ 30
5 Remlichten, elektr. antenne	15	+ 30
6 Mistachterlampen	7,5	56
7 ABS-systeem relais	30	+ 30
8 Linker koplamp, grootlicht	7,5	56a
9 Rechter koplamp, grootlicht en controlelamp	7,5	56a
10 Linker parkeer- en achterlichten, dashboardverlichting	7,5	58
11 Rechter parkeer- en achterlichten, kentekenverlichting	7,5	58
12 Linker koplamp, dimlicht	7,5	56b
13 Rechter koplamp, dimlicht	7,5	56b
14 Airconditioning compressor en ventilator (relais)	30	+ 30
15 Verwarming achterruit en portierspiegels	15	+ 30
16 Verstralers, claxon, alarm	20	+ 30
17 Richtingaanwijzers	15	+ 30
18 Koplampsproeiers	20	+ 30
19 Dynamo, oliedrukmeter, verlichting klok en instrumenten, controlelampen	7,5	+ 15
20 Achteruitrijlichten, bediening verwarming, elementen stoelverwarming	30	+ 15
21 ABS-systeem	3*	+ 15
22 Lichtschakelaar, dagrijlichten en verlichting gordelsluitingen	15	+ 15
23 Ruitwissermotoren, ruitessproeierpomp, kanteldak	15	+ 75
24 Elektrische bediening van zijruiten en van spiegels	30	+ 75
25 Ventilator airconditioning en/of ventilatorverwarming, radio	20	+ 75
26 Motor, ABS systeem	30	+ 30

\*Speciaal type 3 Amp zekering voor ABS systeem

# Overzicht kabelbomen

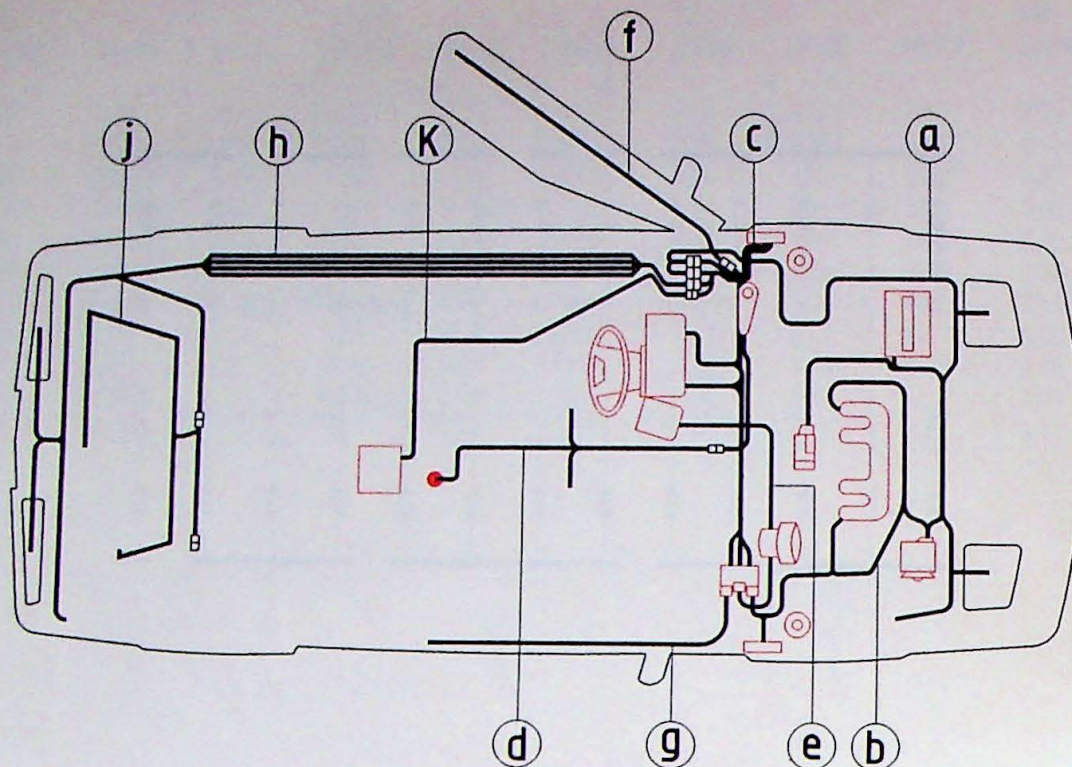

8-015/121

De bedrading van de auto is in tien aparte kabelbomen verdeeld. De letter in een component-referentienummer geeft aan in welke kabelboom het component zit. Bijvoorbeeld, A3 is het nummer van de startmotor in de motorruimte kabelboom.

## Kabelbomen

- a Kabelboom motorruimte
- b Kabelboom brandstofsysteem motor
- c Centrale Kabelboom (dashboard)
- d Kabelboom console
- e Kabelboom verwarmingssysteem
- f Kabelboom bestuurdersportier
- g Kabelboom passagiersportier
- h Kabelboom achterkant
- j Kabelboom achterklep
- k Kabelboom binnenverlichting

Verder zijn er kabelbomen (niet getoond in het schema) voor extra systemen zoals:

- l Kabelboom ABS remsysteem

# Overzicht massapunten

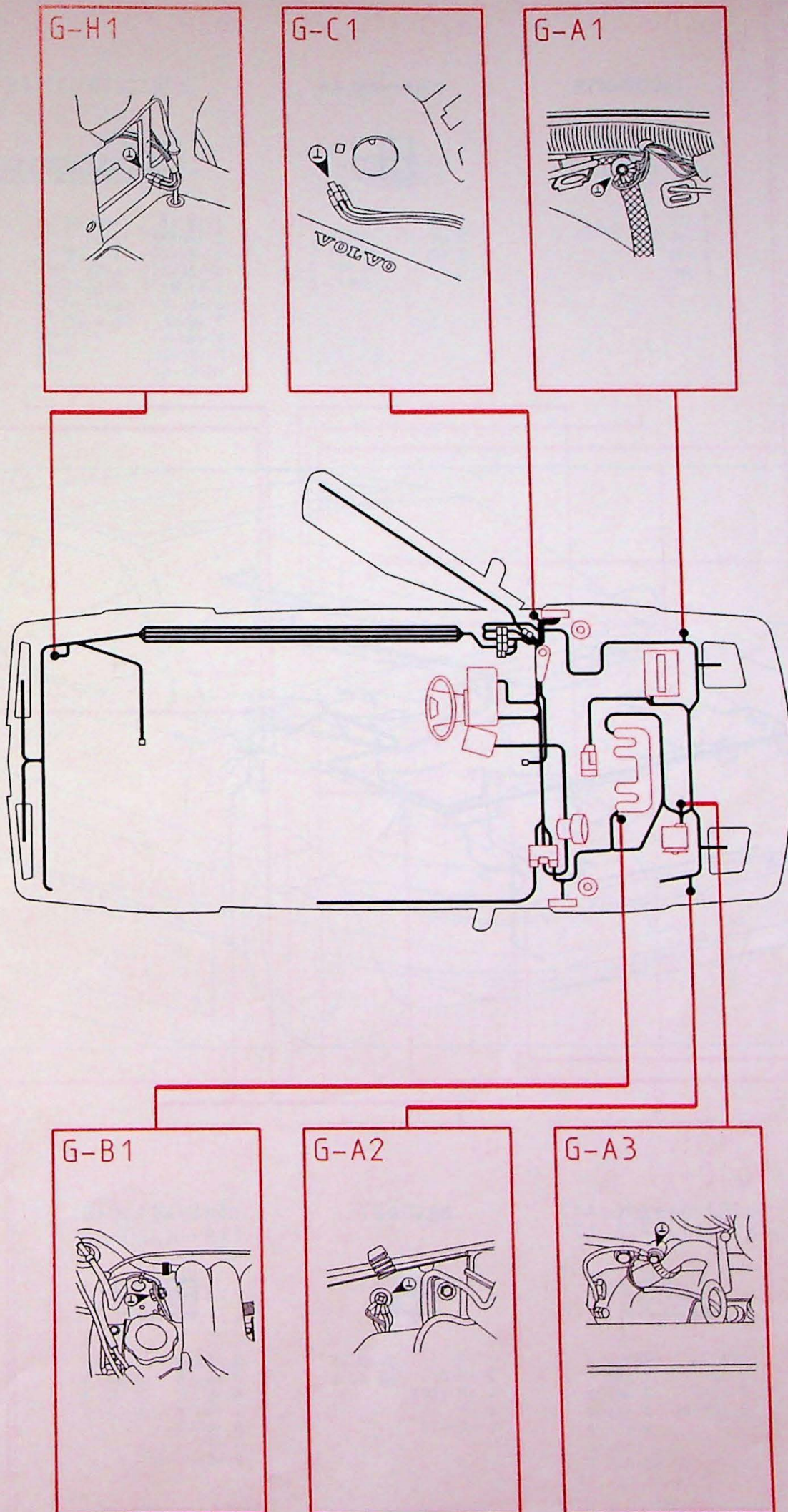

# Connectoren kabelboom a, motorruimte

**a4b**  
a4b → A49

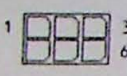

2 = Bl-R  
3 = W-SB  
4 = Bl-Gr  
5 = Y-Br

**a40**  
a40 → A58

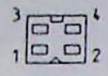

1 = Gr  
2 = W-SB  
3 = Br  
4 = W

**a20**  
a20 → A5, A6

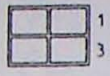

1 = Br  
2 = R  
3 = Or

**a2R**  
a2R ↔ c5R

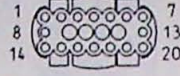

1 = W-SB    11 = Gr-W  
2 = Gn-Br    12 = Gr  
3 = Bl-Gn    13 = W-SB  
4 = Bl-Y    14 = SB  
5 = Y-Br    15 = Gn  
6 = Gn-Y    16 = W  
7 = W-Gn    20 = R-Br  
8 = Gn-Y  
9 = Br-Bl  
10 = Bl-Gr

**a1W**  
a1W ↔ c4W



1 = Br-Bl    12 = Gr-SB  
2 = R-Br    13 = W-Bl  
3 = W-Gn    14 = Gn-R  
4 = Gr-Gn    15 = Gn  
5 = R-Br    16 = Bl-R  
6 = Or    17 = Bl-Gr  
8 = Br-Gr    18 = Br-Gr  
9 = W-Bl    19 = Y  
10 = Gn-R    20 = Gr  
11 = Gn

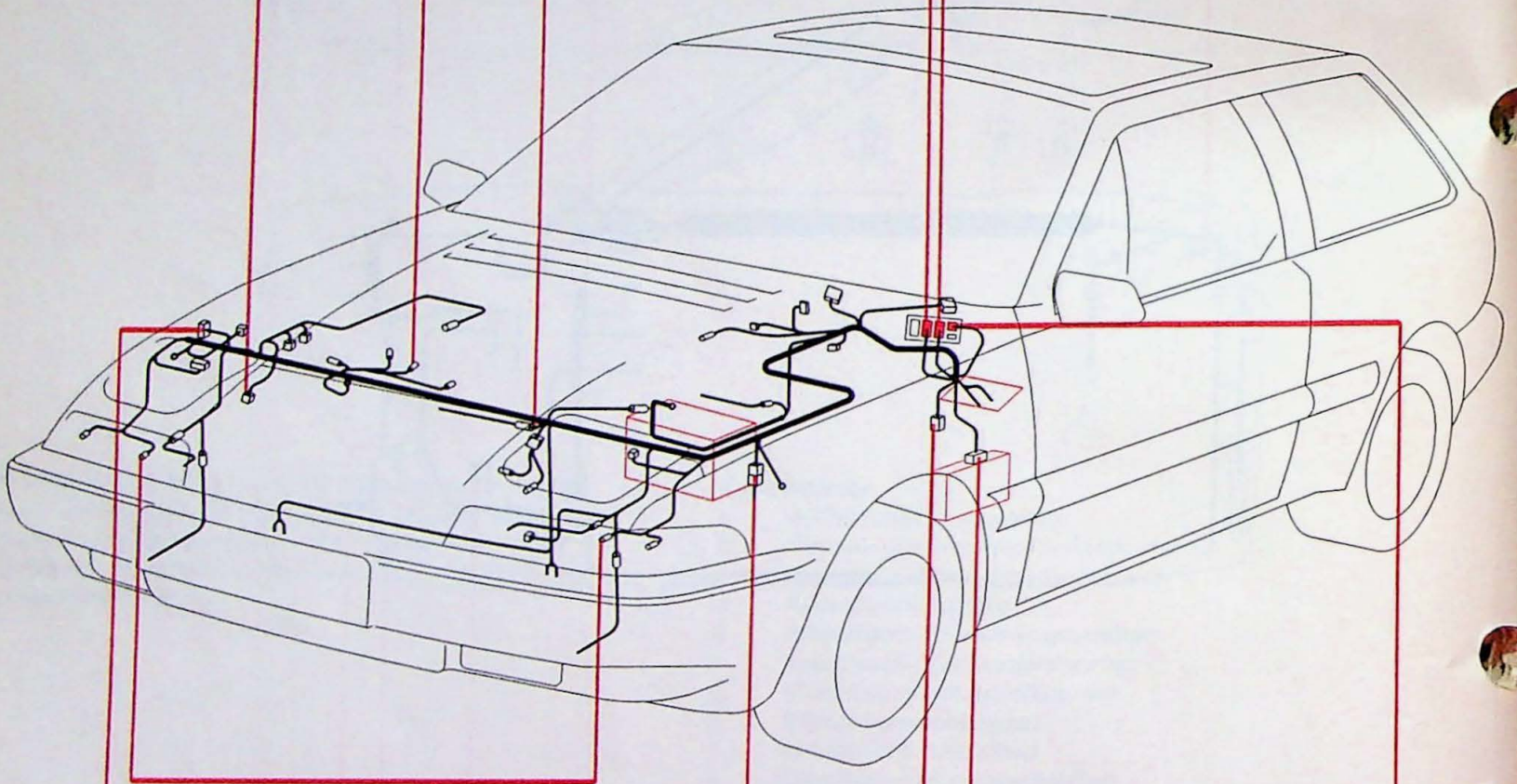

**a13(r)**  
**a13(l)**  
a13(r) → A20  
a13(l) → A30



<L>    <R>  
1 = Br    1 = Br  
2 = Gn-Y    2 = Gn  
3 = W-SB    3 = W  
4 = R-Br    4 = R-Br  
5 = Bl-Gr    5 = Bl-Gr

**a10(r)**  
**a10(l)**  
a10(r) → A16, A17  
a10(l) → A26, A27

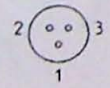

<L>    <R>  
1 = Br    1 = Br  
2 = Gn    2 = W-Gn  
3 = Br-Bl    3 = Y-Br

**a4**  
a4 ↔ c27

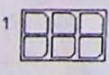

1 = Or  
2 = R-Br  
4 = R (SB)  
5 = R  
6 = Gr-SB

**a5(D)**  
a5(D) ↔ 1.0(D)

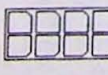

2 = SB-R  
3 = Gr-R  
4 = W  
5 = W-Gn  
6 = Bl-Y  
7 = Y  
8 = Br

**a3**  
a3 ↔ c19

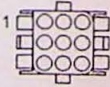

1 = Or  
2 = SB-Br  
4 = Y  
5 = Y-Br  
6 = Br-Bl  
7 = Br  
8 = Gr-W  
9 = W

# Connectoren kabelboom b, brandstofsysteem B18 E

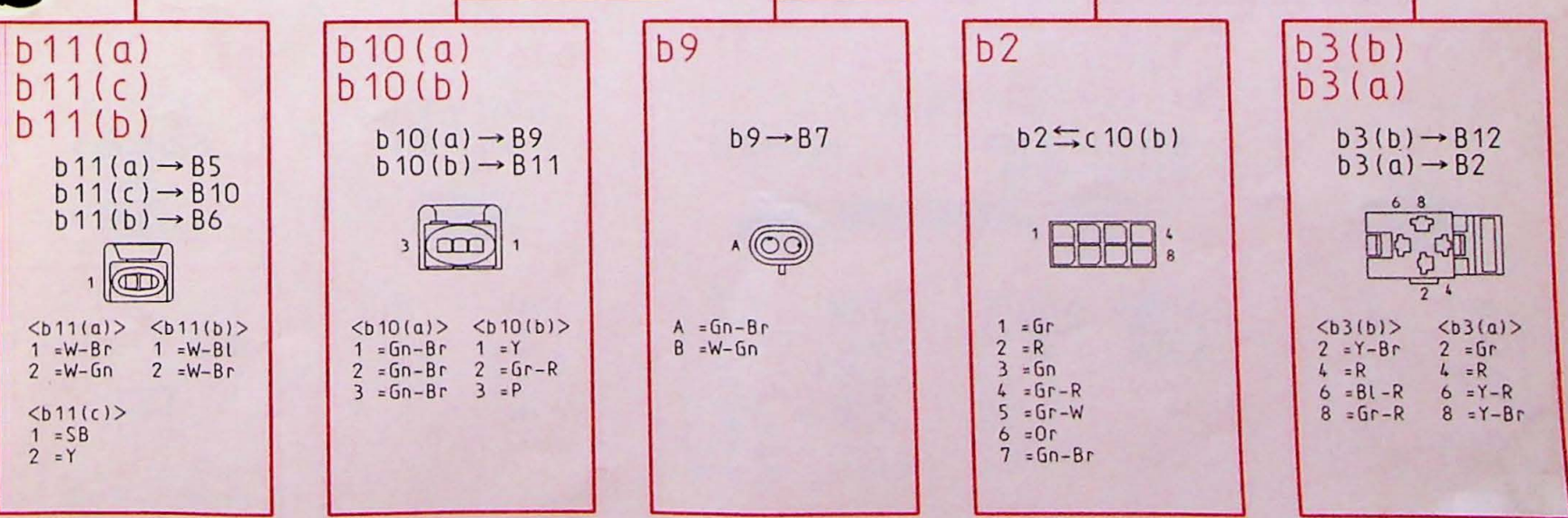
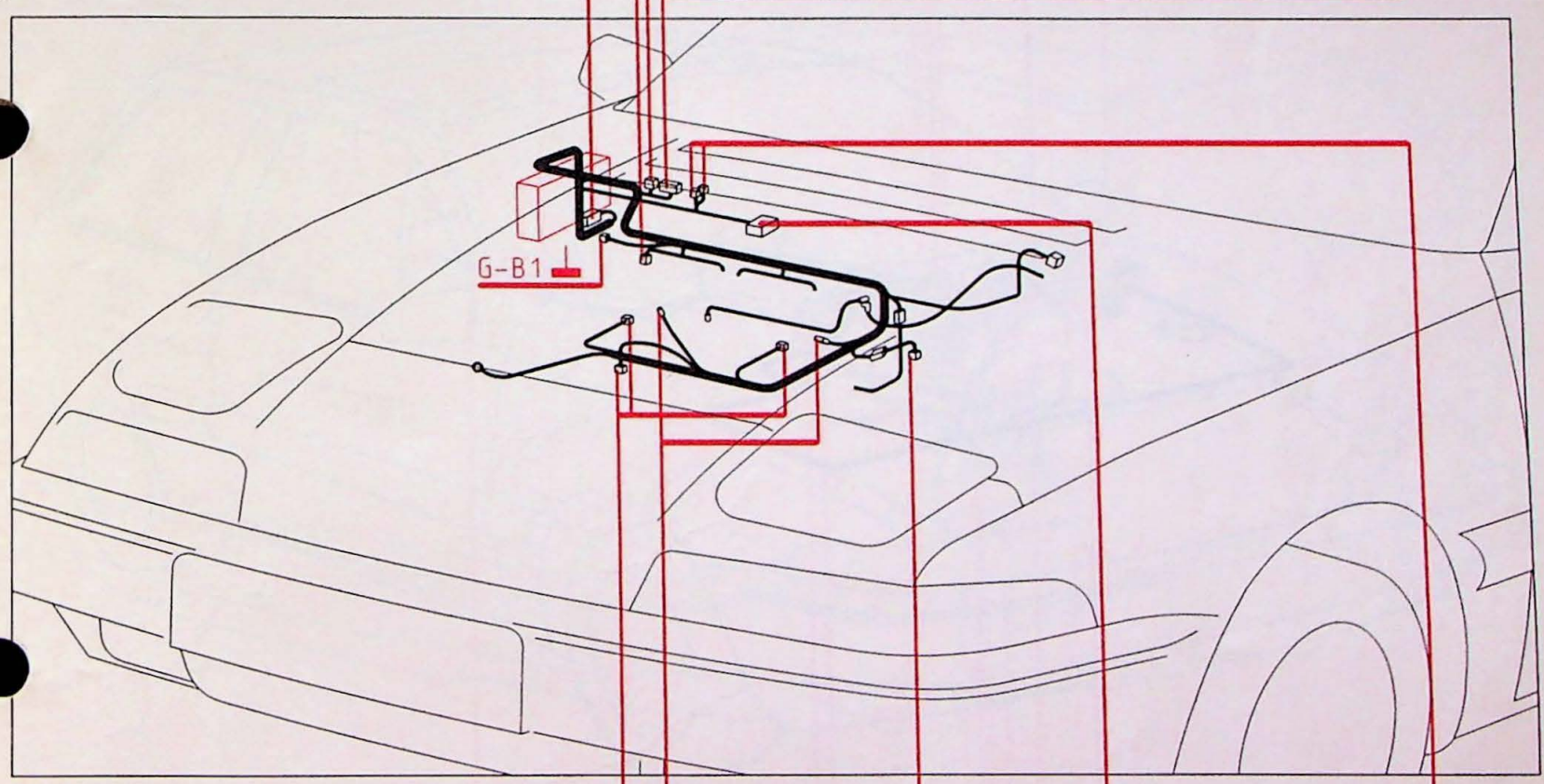
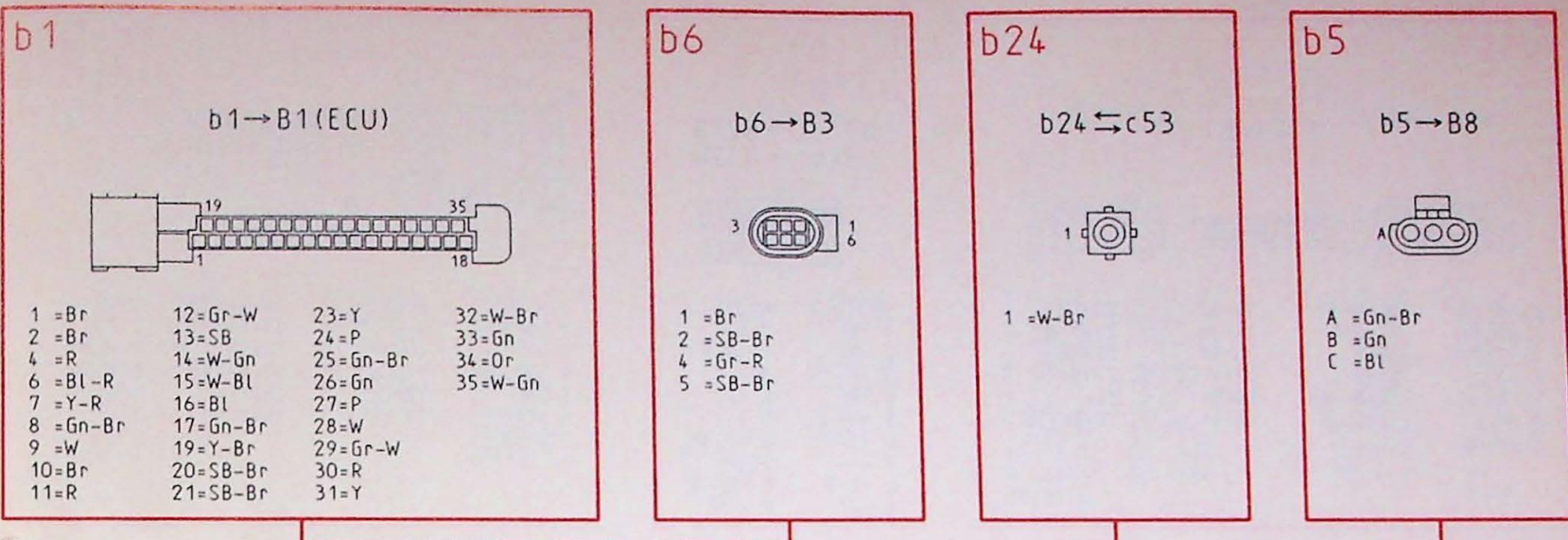

# Connectoren kabelboom b, brandstofsysteem B18 F + FT

b14

b14 → B1

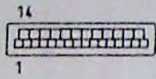

1 = Br-Bl	8 = W-Bl	14 = Bl	20 = SB
2 = W-Br	9 = Y-R	15 = ---	21 = Y-Br
3 = Y-Br	10 = R	16 = Or	22 = SB
4 = ---	11 = Br	17 = Y-SB	23 = Gr-W
5 = Br	12 = Br-Gr	18 = Gr	24 = -
6 = W	13 = Gr-R	19 = Br	25 = Br-SB
7 = W-Gn			

b3(a)  
b3(b)

b3(a) → B2SB  
b3(b) → B12W

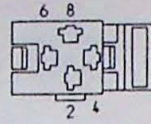

<b3(a)>	<b3(b)>
1 = ---	1 = ---
2 = R	2 = Y-R
3 = ---	3 = ---
4 = R	4 = R
5 = ---	5 = ---
6 = Y-Br	6 = Y-SB
7 = ---	7 = ---
8 = Y-R	8 = Gr-R
9 = ---	9 = ---

b22

b22 → A52

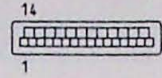

1 = ---	8 = ---	14 = Br-SB	20 = Br
2 = W-Br	9 = -	15 = Gn	21 = O <sub>2</sub>
3 = ---	10 = Y	16 = SB	22 = SB
4 = Br-Gr	11 = O <sub>2</sub>	17 = Br-Bl	23 = SB
5 = R	12 = O <sub>2</sub>	18 = Y-R	24 = ---
6 = Gr	13 = SB	19 = Y-SB	25 = Y
7 = Y-Br			

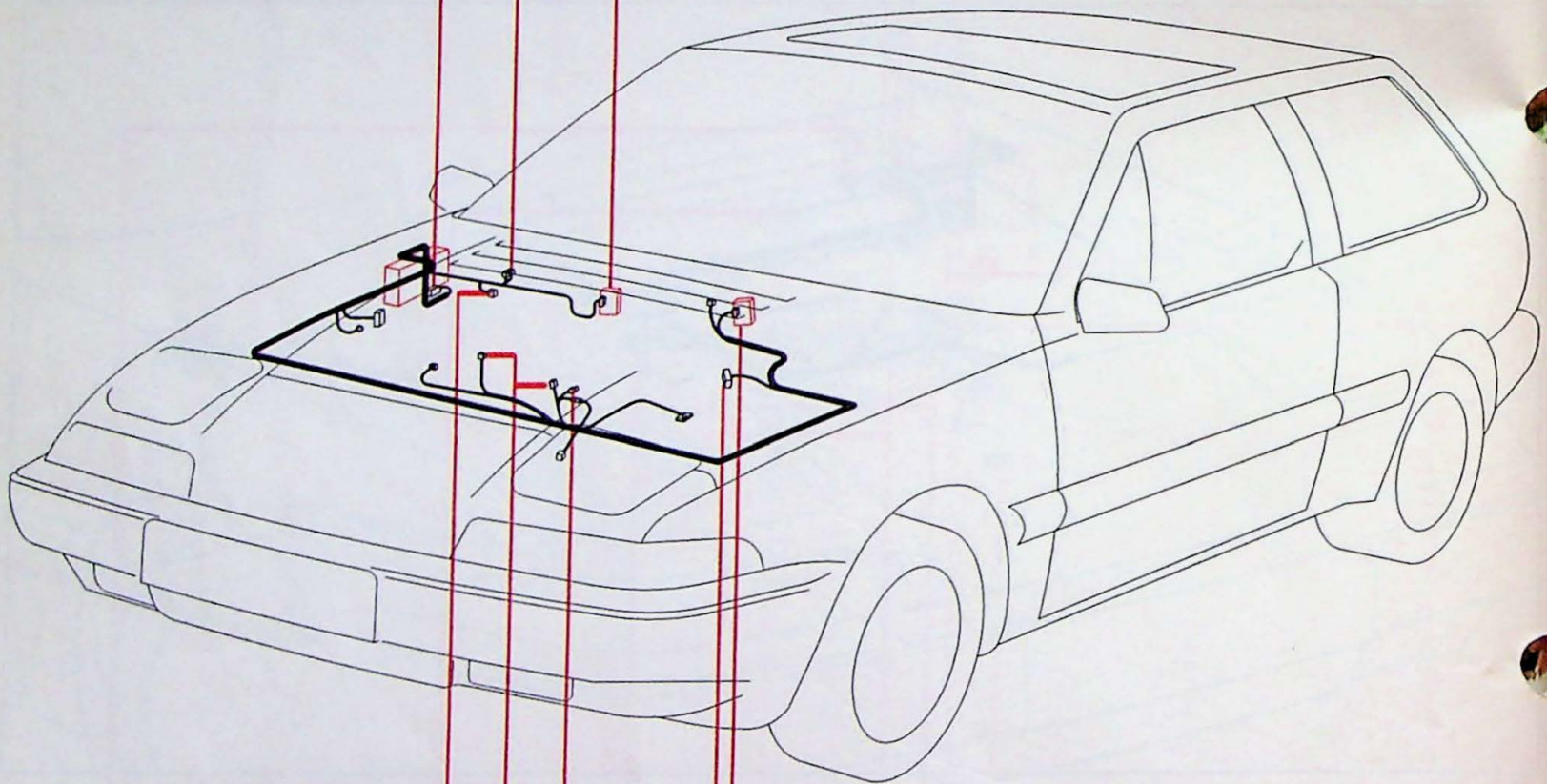

b2(c)

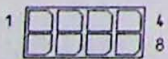

1 = Gr
2 = Or
3 = Gn
4 = Gr-R
5 = ---
6 = ---
7 = Br-Bl
8 = ---

b11(b)  
b11(c)

b11(b) → B16R  
b11(c) → B10



<b11(b)>	<b11(c)>
1 = W-Br	1 = SB
2 = W-Br	2 = O <sub>2</sub>

b21

b21 → B18



1 = SB
2 = O <sub>2</sub>
3 = Y
4 = Y-Br
5 = ---
6 = Br-SB

b16

b16 → B14



1 = Br
2 = W
3 = W-Gn
4 = W-Bl
5 = Y-R
6 = Bl

b20

b20 ↔ A53



1 = O <sub>2</sub>
2 = Br-SB
3 = Gr
4 = SB

# Connectoren kabelboom c, dashboard deel 1

c 10 (a)  
c 10 (b)  
c 10 (c)

c 10 (a) ↔ g1 (a)  
c 10 (b) ↔ e2 (b)  
c 10 (c) ↔ b2 (c)

1 = Y	12 = Br	21 = Gr-SB	31 = Gr
2 = Y-SB	15 = Y	22 = W-SB	32 = Or
3 = Gr	16 = Gn	23 = Gr-Gn	33 = Gn
4 = Gr-W	18 = Y-W	24 = W	34 = Gr-R
5 = Gr-SB		25 = Br-Gr	35 = Gr-W
6 = Y-W		27 = Br	36 = Or
7 = Br-Gr			37 = Br-BL
8 = Br-BL			38 = SB-R
9 = P			
10 = W-Br			

c 6Y

c 6Y ↔ h 1Y

1 = SB-BL	11 = Gr-R
2 = W-Br	13 = BL-Gr
3 = W-BL	14 = BL
4 = Gn	15 = Br-Gr
5 = Gn-R	17 = Gr-SB
6 = Gn-Y	18 = R
7 = Y-Br	19 = W
8 = Br-BL	
9 = Y-W	
10 = Br	

c 5R

c 5R ↔ a 2R

1 = W-SB	11 = Gr-W
2 = Gn-Br	12 = Gr
3 = Bl-Gn	13 = W-SB
4 = Bl-Y	14 = SB
5 = Y-Br	15 = Gn
6 = Gn-Y	16 = W
7 = W-Gn	17 = Or
8 = Gn-Y	18 = SB-R
9 = Br-BL	20 = R-Br
10 = Bl-Gr	

c 4W

c 4W ↔ a 1W

1 = Br-BL	11 = Gn
2 = R-Br	12 = Gr-SB
3 = W-Gn	13 = W-BL
4 = Gr-Gn	14 = Gn-R
5 = R-Br	15 = Gn
6 = Or (BL)	16 = BL-R
8 = Br-Gr	17 = BL-Gr
9 = W-BL	18 = Br-Gr
10 = Gn-R	19 = Y
	20 = Gr

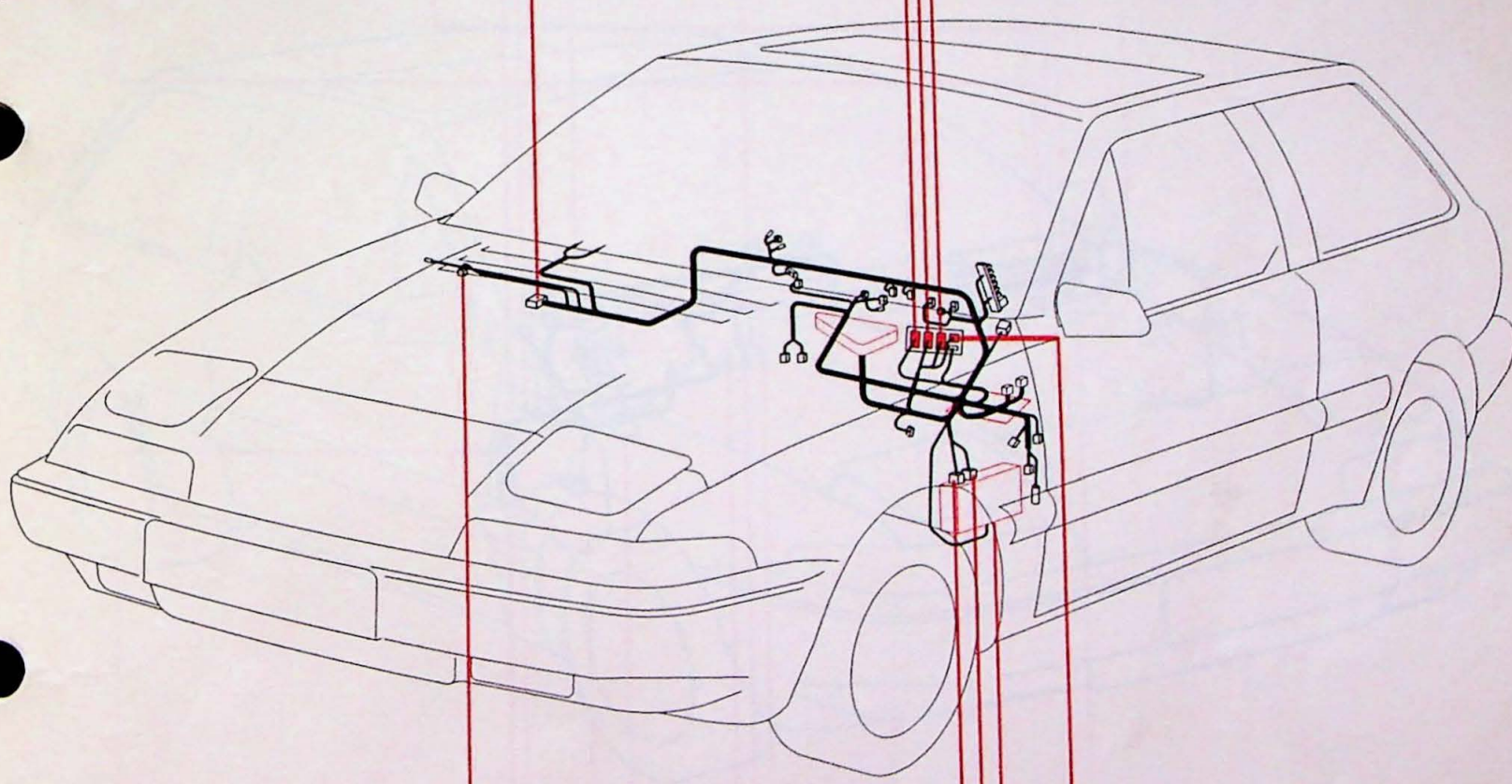

c 53

c 53 → b 24

1 = Bl

c 3 (C)

c 3 (C) → 1.0 (C)

c 1 (A)

c 1 (A) → 1.0 (A)

2 = Br-BL	11 = Gn-Br	21 = Y-SB	32 = W-SB
3 = W-Br	12 = BL-Gr	22 = Y-Br	33 = W
4 = BL	14 = Gr-W	24 = Y-W	34 = BL-Gr
5 = Br	15 = Y-Br	25 = SB-BL	35 = W-Gn
6 = SB	16 = Br-Gr	26 = BL-Y	
7 = BL-R	17 = Gn	27 = Gr-Gn	
8 = SB-Br	18 = W-Br	28 = R-Br	
9 = Gr-Gn	19 = Br-Gr	29 = Gn	
10 = Gn-SB	20 = SB-R	30 = R	

c 19

c 19 → a 3

1 = Or
2 = SB-Br
4 = Y
5 = Y-Br
6 = Br-BL
7 = Br
8 = Gr
9 = W

c 2 (B)

c 2 (B) → 1.0 (B)

1 = Y-W	3 = Y-W
2 = Gn-Br	4 = Gn-Br

# Connectoren kabelboom c, dashboard deel 2

**c 22**  
c 22 → c 25



- 1 = R-Br
- 2 = Bl
- 3 = R
- 4 = W-SB
- 5 = Y-SB
- 6 = ---
- 7 = W
- 8 = Y
- 9 = Br

**c 16**  
c 16 ↔ k 1



- 1 = Br
- 2 = SB-R
- 3 = R-Br
- 4 = W-SB
- 5 = Or
- 6 = ---

**c 4 3W**  
c 4 3W → l 2W

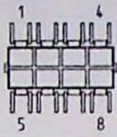

- 1 = Br
- 2 = Gn-Y
- 3 = Or
- 4 = Y
- 5 = Bl-r
- 6 = W
- 7 = SB
- 8 = Bl

**c 4 2SB**  
c 4 2SB → l 3SB

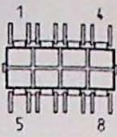

- 1 = Br
- 2 = R
- 3 = W-R
- 4 = W-SB
- 5 = Bl
- 6 = Gr
- 7 = SB
- 8 = Gn-Br

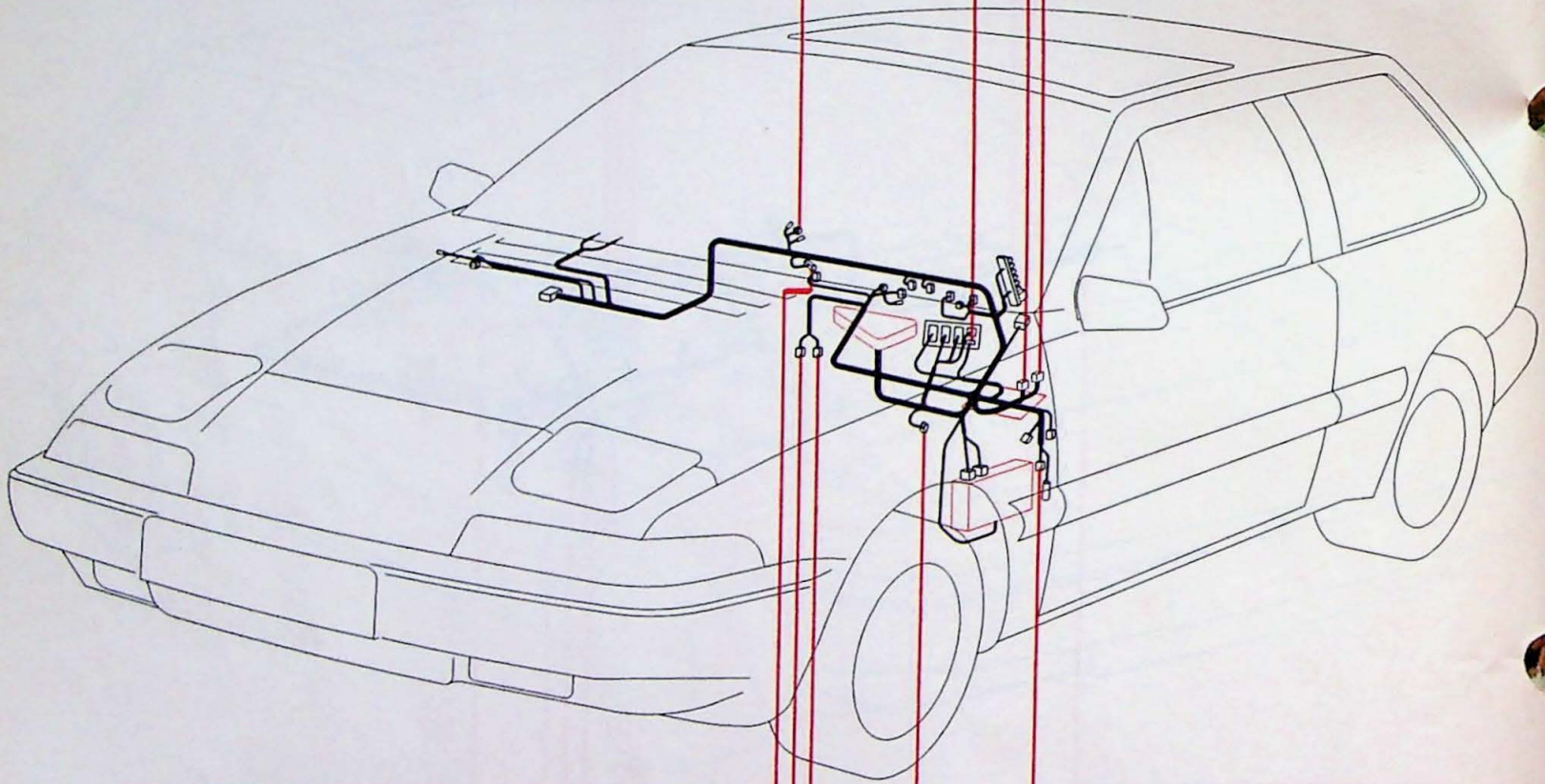

**c 23**  
c 23 → c 32, c 33

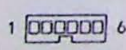

- 1 = ---
- 2 = ---
- 3 = Y
- 4 = Br-Gr
- 5 = Gr-W
- 6 = Br

**c 7**  
c 7 ↔ d 1

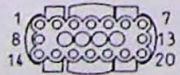

- 1 = Bl-Y
- 2 = Bl-Y
- 3 = Br-Gr
- 4 = Y-Br
- 5 = Gr
- 6 = Gn-SB
- 7 = Gr
- 8 = Gr-SB
- 9 = R-Br
- 10 = Gr-R
- 11 = P
- 12 = W-Br
- 13 = Gr-W
- 14 = Gr
- 15 = Gr-SB
- 16 = Gr-W
- 17 = Br-Bl
- 18 = ---
- 19 = ---
- 20 = ---

**c 8SB**  
c 8SB ↔ d 2SB

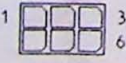

- 1 = Gr-Gn
- 2 = W-SB
- 3 = P
- 4 = W-Br
- 5 = Br
- 6 = ---

**c 27**  
c 27 ↔ a 4

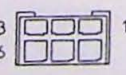

- 1 = Or
- 2 = R-Br
- 3 = SB
- 4 = R
- 5 = R-W
- 6 = Gr-SB

**c 9**  
c 9 ↔ f 1

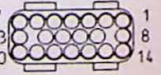

- 1 = W
- 2 = W-SB
- 3 = Gr
- 4 = Gr-W
- 5 = Gr-SB
- 6 = Y-W
- 7 = Br-Gr
- 8 = Br-Bl
- 9 = P
- 10 = W-Br
- 11 = ---
- 12 = Br
- 13 = Gr-R
- 14 = ---
- 15 = Y
- 16 = Gn
- 17 = ---
- 18 = Bl-R
- 19 = ---
- 20 = ---

# Connectoren kabelboom c RHD

**c6Y**  
c6Y ↔ h1Y

1 = SB-BL	11 = Gr-R
2 = --	12 = --
3 = W-BL	13 = Bl-Gr
4 = Gn	14 = Bl
5 = Gn-R	15 = Br-Gr
6 = Gn-Y	16 = --
7 = Y-Br	17 = Gr-SB
8 = Br-BL	18 = R
9 = Y-W	19 = --
10 = Bl-Y	20 = --

**c5R**  
c5R ↔ a2R

1 = W-SB	11 = Gr-W
2 = Gn-Br	12 = Gr
3 = Bl-Gn	13 = W-SB
4 = Bl-Y	14 = SB
5 = Y-Br	15 = Gn
6 = Gn-Y	16 = W-SB
7 = W-Gn	17 = Gr-SB
8 = Gn-Y	18 = Bl-R
9 = Br-BL	19 = --
10 = Bl-Gr	20 = R-Br

**c4W**  
c4W ↔ a1W

1 = Br-BL	11 = Gn
2 = R-Br	12 = Gr-SB
3 = W-Gn	13 = W-BL
4 = Gr-Gn	14 = Gn-R
5 = R-Br	15 = Gn
6 = Or	16 = Bl-R
7 = Or	17 = Bl-Gr
8 = Br-Gr	18 = Br-Gr
9 = W-BL	19 = Bl
10 = Gn-R	20 = Gr

**c10(a)**  
c10(a) ↔ g1(a)

1 = Y	11 = --
2 = Y-SB	12 = Br
3 = Gr	13 = --
4 = Gr-W	14 = --
5 = Gr-SB	15 = Y
6 = Y-W	16 = Gn
7 = Br-Gr	17 = --
8 = Br-BL	18 = Y-W
9 = R	19 = --
10 = W-Br	20 = --

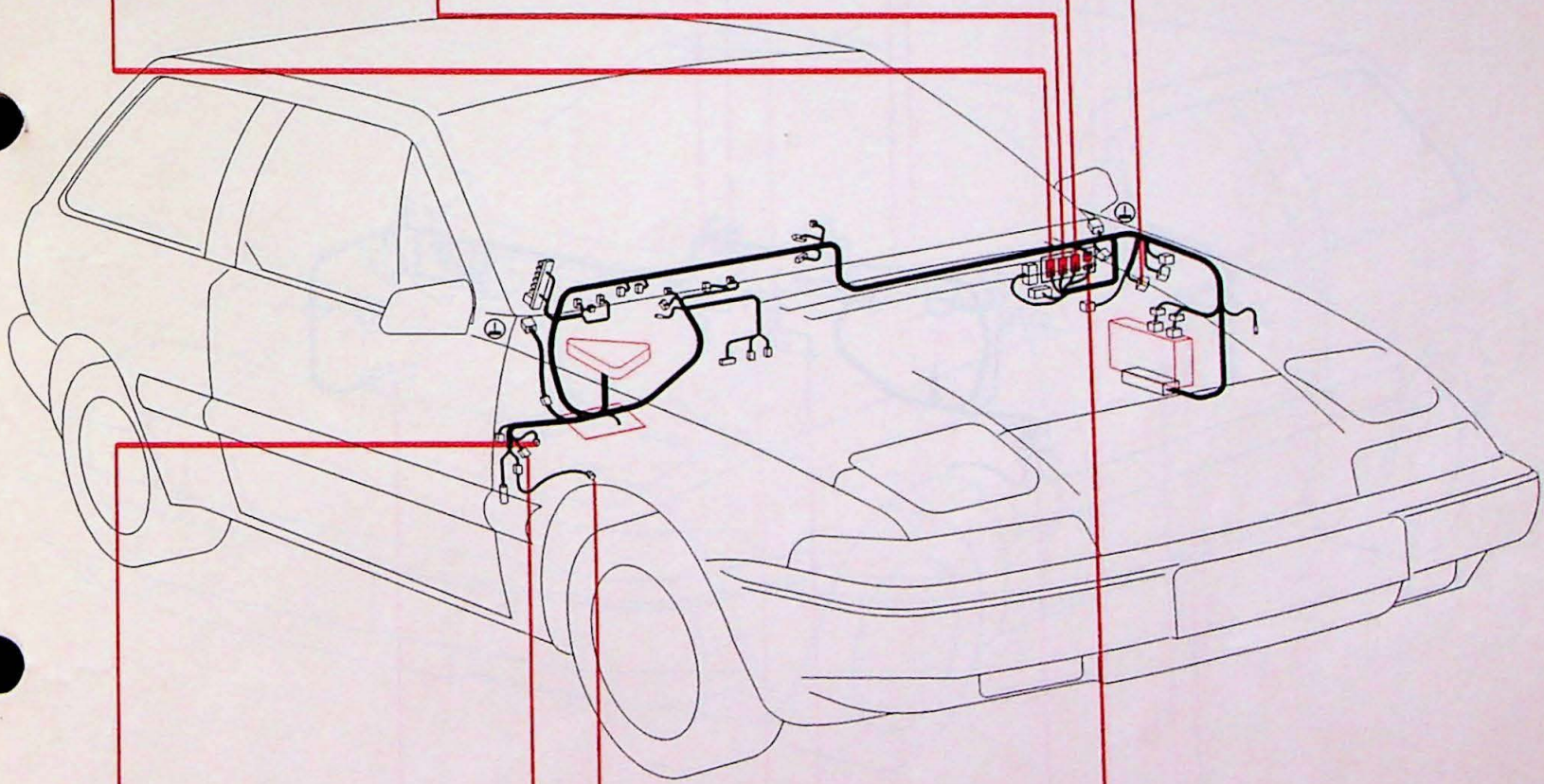

**c53**

1 = Bl

**c37**

1 = Gr
2 = Or
3 = Gn
4 = Gr-R
5 = Gr-W
6 = Or
7 = Br-BL
8 = --

**c40**

1 = W-Br
2 = Br
3 = Gr-R
4 = Bl-Y

**c19**  
c19 → a3

1 = Or
2 = SB-Br
3 = --
4 = Y
5 = Y-Br
6 = Br-BL
7 = Br
8 = Gr-W
9 = W

# Connectoren kabelboom c RHD

c20Gr

c20Gr → 4.0(II)

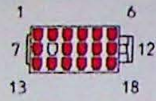

- |            |            |
|------------|------------|
| 1 = Gr-SB  | 11 = Gn-SB |
| 2 = Gr     | 12 = Y-Br  |
| 3 = R-Br   | 13 = Bl    |
| 4 = W-Bl   | 14 = W-SB  |
| 5 = Gn     | 15 = Gn-Y  |
| 6 = SB-Br  | 16 = R-Br  |
| 7 = Gn-Br  | 17 = Or    |
| 8 = --     | 18 = Gr    |
| 9 = W      |            |
| 10 = Br-Bl |            |

c21Gn

c21Gn → 4.0(I)

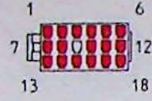

- |            |            |
|------------|------------|
| 1 = Bl-Gn  | 11 = Gn-R  |
| 2 = Bn     | 12 = Gr-W  |
| 3 = SB     | 13 = Bl-Gr |
| 4 = Bl     | 14 = Br-Gr |
| 5 = Br-Gr  | 15 = Br-Bl |
| 6 = Y-SB   | 16 = W-Br  |
| 7 = Y-W    | 17 = Gr-W  |
| 8 = BR     | 18 = SB    |
| 9 = --     |            |
| 10 = Br-Bl |            |

c33

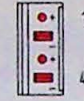

- |          |
|----------|
| 1 = SB-Y |
| 2 = SB-W |
| 3 = Y    |
| 4 = W    |

c32

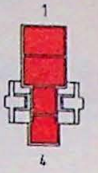

- |          |
|----------|
| 1 = Br   |
| 2 = R-Br |
| 3 = SB-R |
| 4 = R    |

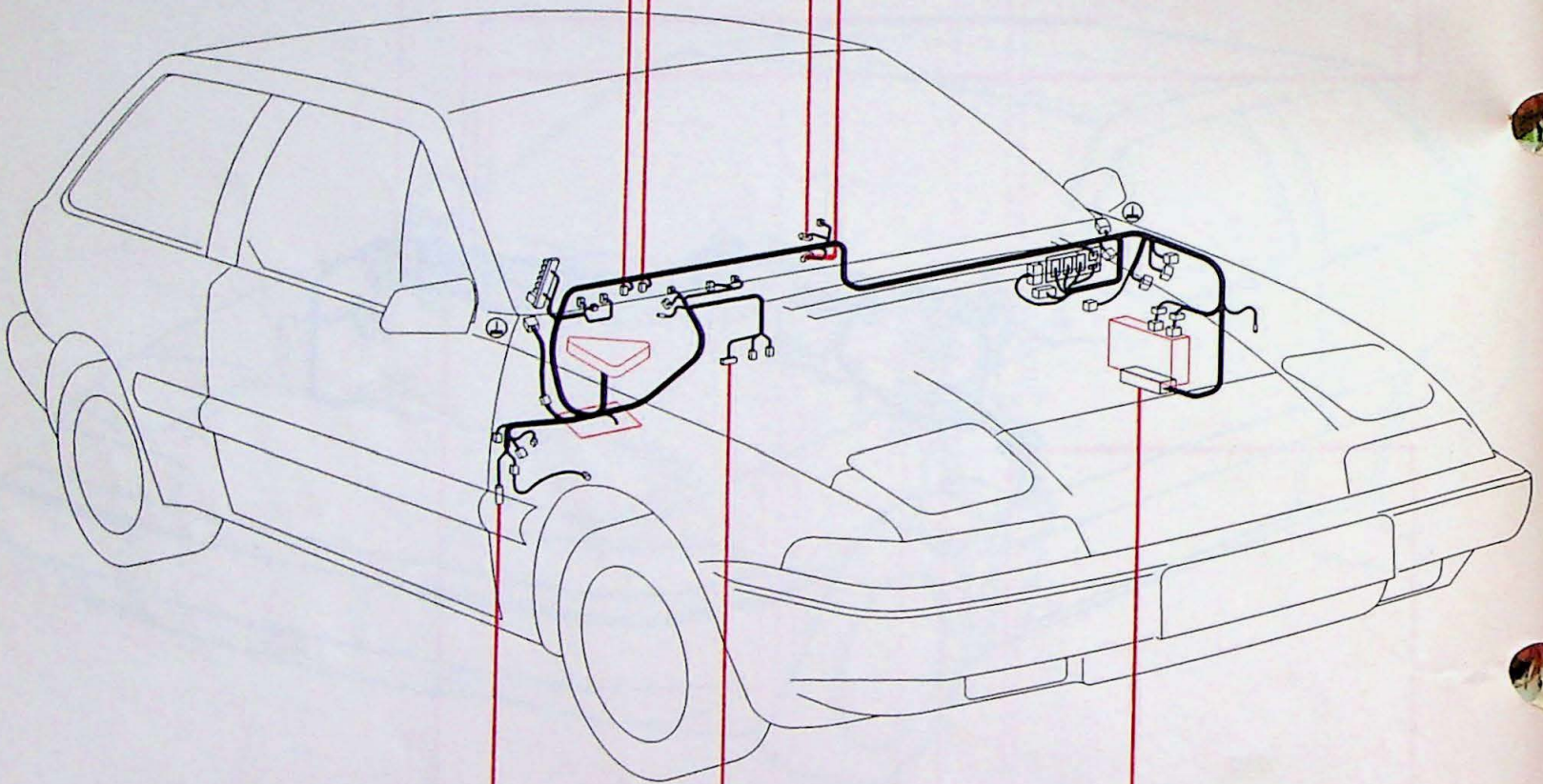

c9

c9 ↔ f1

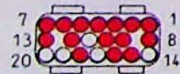

- |           |           |
|-----------|-----------|
| 1 = W     | 11 = --   |
| 2 = W-SB  | 12 = Br   |
| 3 = Gr    | 13 = Gr-R |
| 4 = Gr-W  | 14 = --   |
| 5 = Gr-SB | 15 = Y    |
| 6 = Y-W   | 16 = Gn   |
| 7 = Br-Gr | 17 = --   |
| 8 = Br-Bl | 18 = Bl-R |
| 9 = R     | 19 = --   |
| 10 = W-Br | 20 = --   |

c7

c7 ↔ D1



- |           |            |
|-----------|------------|
| 1 = Bl-Y  | 11 = R     |
| 2 = Bl-Y  | 12 = W-Br  |
| 3 = Br-Gr | 13 = Gr-W  |
| 4 = Y-Br  | 14 = Gr    |
| 5 = Gr    | 15 = Gr-SB |
| 6 = Gn-SB | 16 = Gr-W  |
| 7 = Gr    | 17 = Br-Bl |
| 8 = Gr-SB | 18 = --    |
| 9 = R-Br  | 19 = --    |
| 10 = Gr-R | 20 = --    |

c1(A)

c1(A) → 1.0(A)

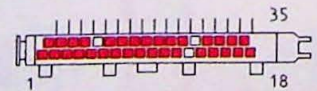

- |            |            |            |            |
|------------|------------|------------|------------|
| 1 = --     | 11 = Gn-Br | 21 = Y-SB  | 31 = --    |
| 2 = Br-Bl  | 12 = Bl-Gr | 22 = Y-Br  | 32 = W-SB  |
| 3 = Br-Bl  | 13 = --    | 23 = --    | 33 = W     |
| 4 = W-Br   | 14 = Gr-W  | 24 = Y-W   | 34 = Bl-Gr |
| 5 = Br     | 15 = Y-Br  | 25 = SB-Bl | 35 = W-Gn  |
| 6 = SB     | 16 = Br-Gr | 26 = Bl-Y  |            |
| 7 = Bl-R   | 17 = Gn    | 27 = R-Br  |            |
| 8 = SB-Br  | 18 = W-Br  | 28 = R-Br  |            |
| 9 = Gr-Gn  | 19 = Br-Gr | 29 = Gn    |            |
| 10 = Gn-SB | 20 = SB-R  | 30 = R     |            |

# Connectoren kabelboom c RHD

**c 1**

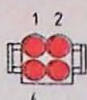

11 = SB-W  
22 = SB-Y  
38 = W  
44 = Y

**c 4 3SB**  
c 4 3SB ↔ l 3SB

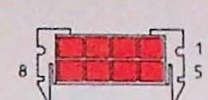

1 = Br  
2 = R  
3 = W-R  
4 = W-SB  
5 = Or  
6 = Gr-W  
7 = Gn  
8 = Gn-Br

**c 4 2W**  
c 4 2W ↔ l 2

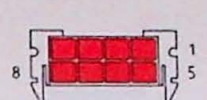

1 = Br  
2 = Gn-Y  
3 = Or  
4 = Y  
5 = Bl-R  
6 = W  
7 = SB  
8 = Or

**c 16**  
c 16 ↔ k 1

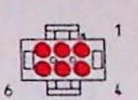

1 = Br  
2 = SB-R  
3 = R-Br  
4 = W-SB  
5 = Or  
6 = --

**c 27**  
c 27 ↔ a 4

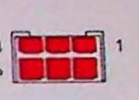

1 = Or  
2 = R-Br  
3 = R  
4 = Br  
5 = R-W  
6 = Gr-SB

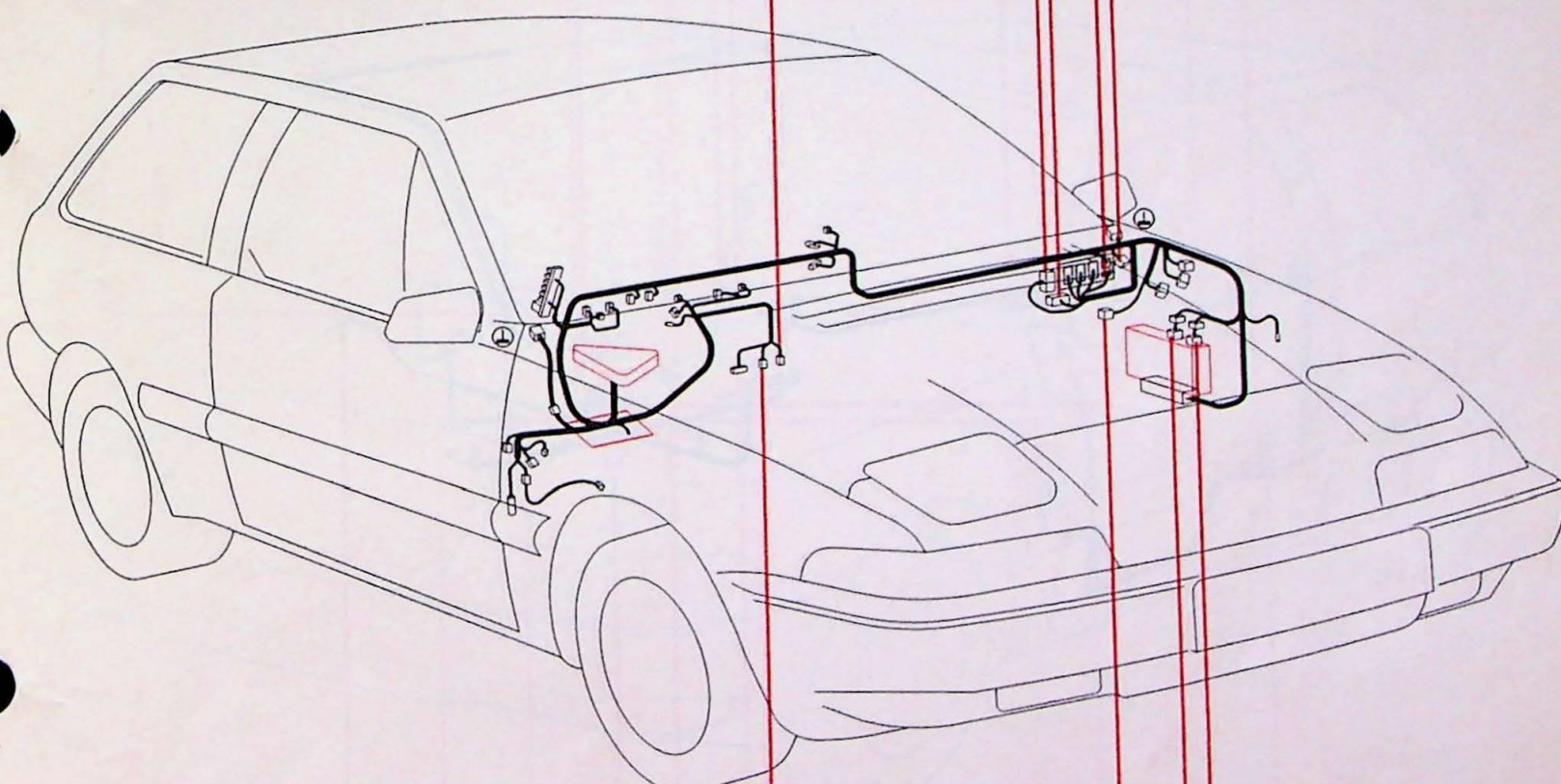

**c 34 (l+r)**

<l>  
1 = Y  
2 = Y-SB

<r>  
1 = W-SB  
2 = W

**c 8SB**  
c 8SB ↔ d 2SB



1 = Gr-Gn  
2 = W-SB  
3 = R  
4 = W-Br  
5 = Br  
6 = --

**c 10 (b)**  
c 10 (b) ↔ e 2 (b)

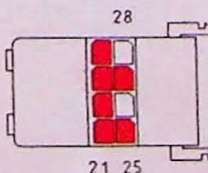

21 = Gr-SB  
22 = W-SB  
23 = Gr-Gn  
24 = W  
25 = Br-Gr  
26 = --  
27 = Br  
28 = --

**c 2 (B)**  
c 2 (B) → 1.0 (B)

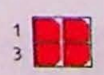

1 = Y-W  
2 = Y-Br  
3 = Y-W  
4 = Y-Br

**c 3 (C)**  
c 3 (C) → 1.0 (C)



1 = Or  
2 = Bl-Y  
3 = W-Bl  
4 = W-Br  
5 = --  
6 = W-Gr

# Connectoren kabelbomen d, e en k

**e2(b)**

e2(b) ↔ c 10(b)

1987	1988
1 = Gr-SB	1 = Gr-SB
2 = W-SB	2 = W
3 = Gr-Gn	3 = Gr-Gn
4 = W	4 = W
5 = Br-Gr	5 = Br-Gr
7 = Br&W-Br	7 = W

**e6**

e6 → E3

1987	1988
1 = Bl	1 = W-Gn
2 = W-Bl	2 = W-Bl
3 = W-Gn	3 = W-Gn
4 = W	4 = R
+ = W-SB	+ = W-SB

**e1**

e1 ↔ 5.0

1 = Br-Gr
2 = Gr-SB
3 = Y
4 = Bl
5 = Gr-Gr
6 = W
7 = W-Br
8 = Br

**e5**

e5 → 5.0

1987	1988
1 = W-Gn	1 = W-SB
2 = W-R	2 = W
3 = W	3 = W
4 = W	4 = W-R
5 = W-SB	

**k1**

k1 ↔ c 16

1 = Br
2 = SB-R
3 = R-Br
4 = W-SB
5 = Or

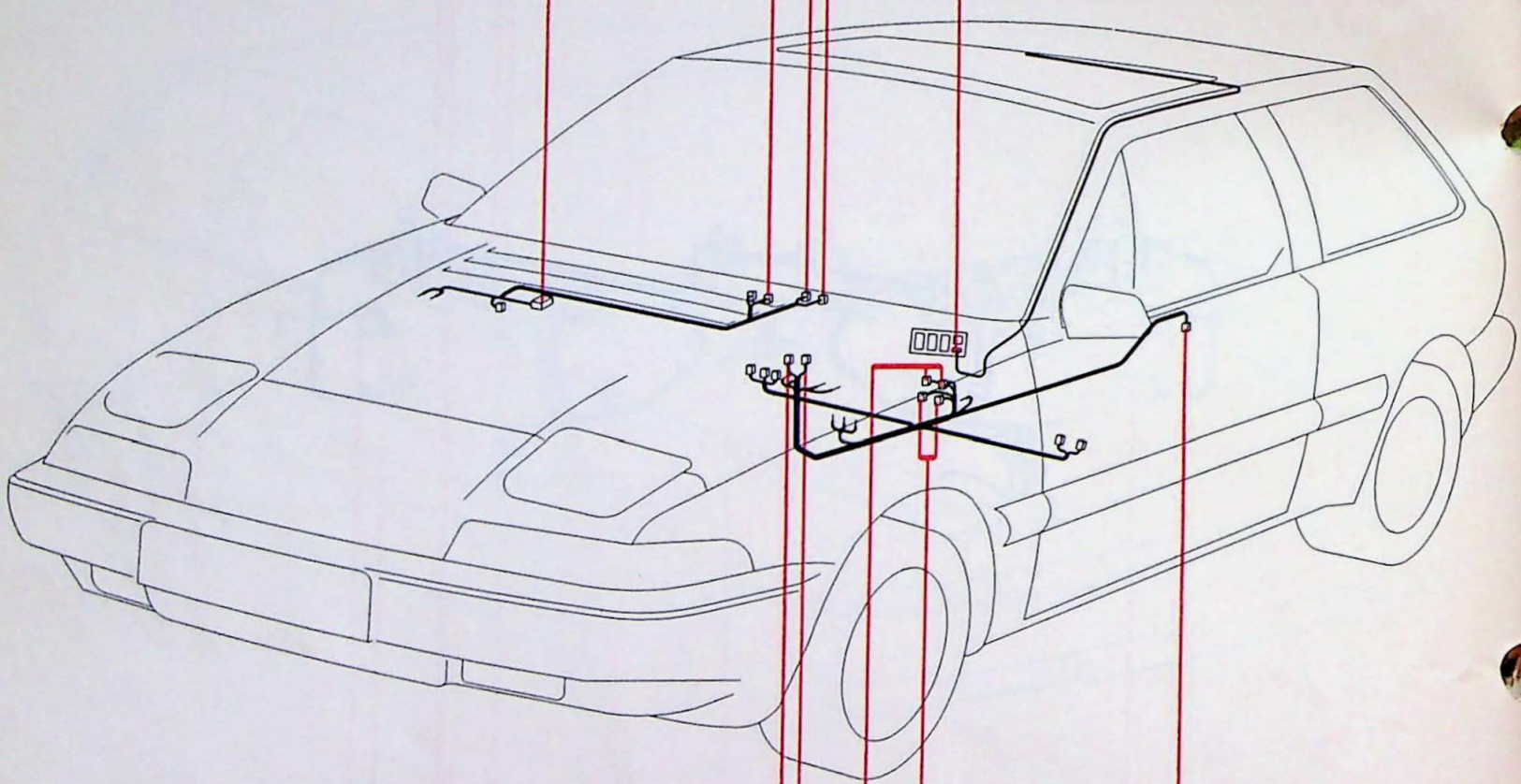

**d1**

d1 ↔ c 7

1 = Bl-Y	11 = P
2 = Bl-Y	12 = W-Br
3 = Br-Gr	13 = Gr-W
4 = Y-Br	14 = Gr
5 = Gr	15 = Gr-SB
6 = Gn-SB	16 = Gr-W
7 = Gr	17 = Br-Bl
8 = Gr-SB	18 = Gn
9 = R-Br	19 = Y
10 = Gr-R	20 = Br

**d2SB**

d2SB ↔ c 8SB

1 = Gr-Gn
2 = W-SB
3 = P
4 = W-Br
5 = Br
6 = --

**d11(b)**  
**d11(a)**

d11(b) → D10  
d11(a) → D7

1 = Gr
2 = Br
3 = Gr-SB
4 = W-SB
5 = Gr-W

**d12(b)**  
**d12(a)**

d12(b) → D9  
d12(a) → D8

1 = P
2 = W-Br
3 = Br
4 = W-SB
5 = Br

**d6**

d6 → D19, D20

1 = Gr-R
2 = Gn-SB
3 = Br-Bl
4 = Br

# Connectoren kabelbomen f, g

1(a)

g1(a) ↔ c10(a)

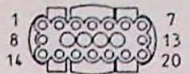

11 = Y	12 = Br
22 = Y-SB	15 = Y
38 = Gr	16 = Gn
44 = Gr-W	17 = SB-Br
55 = Gr-SB	18 = Y-W
66 = Y-W	19 = R
77 = Br-Gr	20 = SB
88 = Br-Bl	
99 = P	
110 = W-Br	

g2  
f2

g2 → G1, G5  
f2 → F1, F5

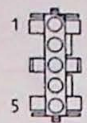

<R>	<L>
1 = Gr	1 = Gr
2 = Gr-W	2 = Gr-W
3 = Gr-SB	3 = Gr-SB
4 = Y-W	4 = Y-W
5 = Br	5 = Br

g5

g5 → G4

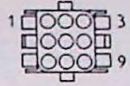

1 = Br
2 = Y-W
3 = SB-Br
4 = Y
5 = Gn
6 = Br
8 = R
9 = SB

g4  
f4

g4 → G3  
f4 → F3



<R>	<L>
1 = Br	1 = Br
2 = Br-Gr	2 = Br-Gr
3 = Br-Bl	3 = Br-Bl

f6

f6 → F6, F7



1 = Br
2 = Gr-R
3 = Bl-R

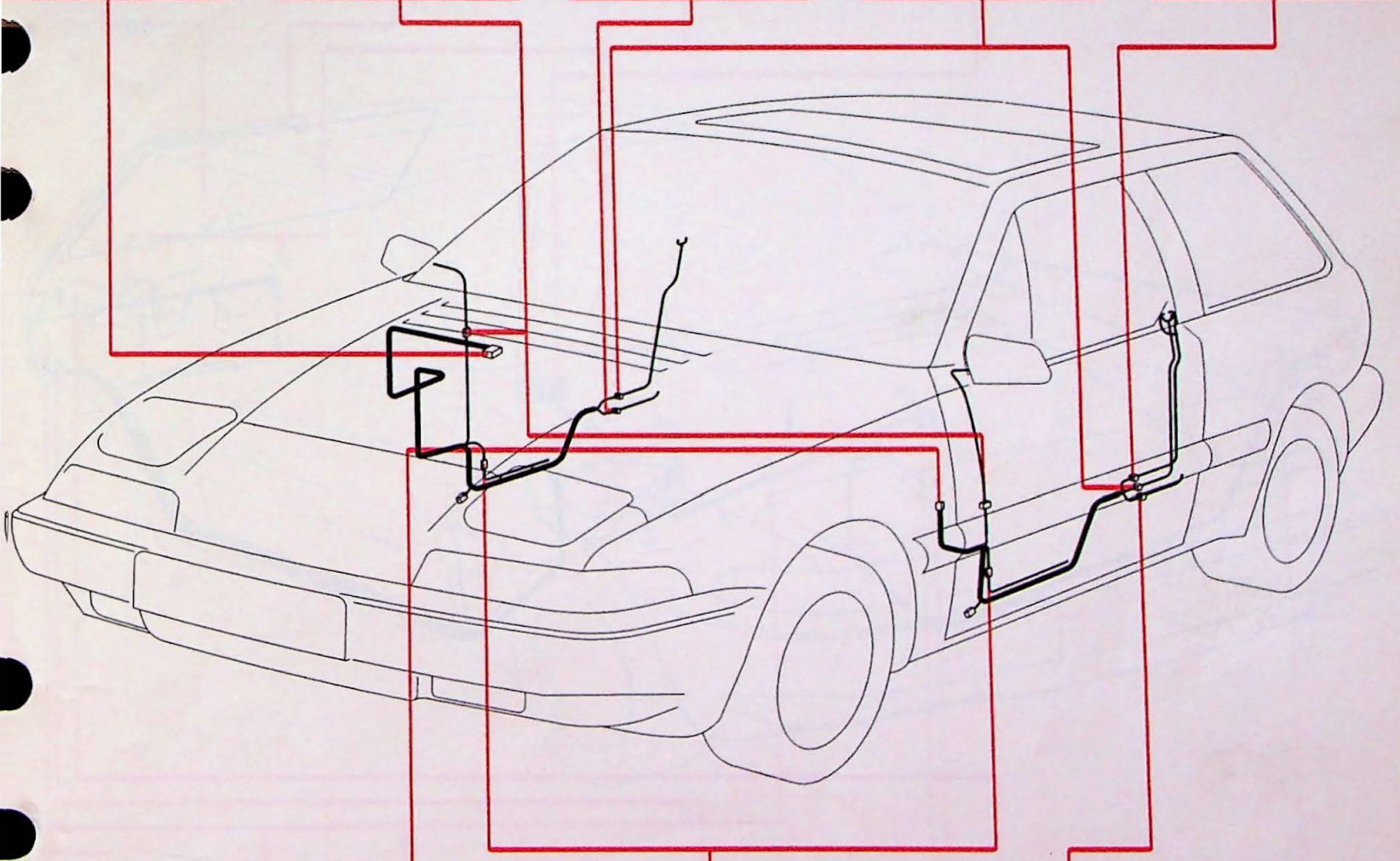

f1

f1 ↔ c9

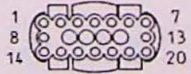

1 = W	12 = Br
2 = W-SB	13 = Gr-R
3 = Gr	15 = Y
4 = Gr-W	16 = Gn
5 = Gr-SB	17 = W-Br
6 = Y-W	18 = Bl-R
7 = Br-Gr	19 = R
8 = Br-Bl	20 = SB
9 = P	
10 = W-Br	

g3  
f3

f3 → F2  
g3 → G2



<R>	<L>
1 = P	1 = P
2 = W-Br	2 = W-Br

f5

f5 → F4



1 = Br
2 = Bl-R
3 = W-Br
4 = Y
5 = Gn
6 = Br
7 = Gr-R
8 = R
9 = SB

# Connectoren kabelbomen h, j

**h1Y**

h1Y ↔ c6Y

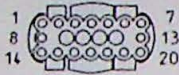

1 = SB-Bl	11 = Gr-R
2 = W-Br	13 = Bl-Gr
3 = W-Bl	14 = Bl
4 = Gn	15 = Br-Gr
5 = Gn-R	17 = Gr-SB
6 = Gn-Y	18 = R
7 = Y-Br	
8 = Br-Bl	
9 = Y-W	
10 = Br	

**h9(r)**  
**h9(l)**

h9(r) → H1, H6  
h9(l) → H11, H16

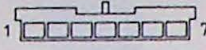

<h9(r)>	<h9(l)>
1 = Bl-Y	1 = W-Bl
2 = Br-Bl	2 = Br-Bl
3 = Y-Br	3 = Y-Br
4 = Bl-Y	4 = W-Bl
5 = Br-Gr	5 = Br-Gr
6 = Br	6 = Br
7 = Gn-Y	7 = Gn-R

**h4**

h4 ↔ j1

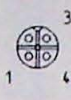

1 = Y-W
2 = W-Bl
3 = Gn
4 = Br-Gn
1 = Br

**j2**

j2 → J2



2 = SB
3 = SB

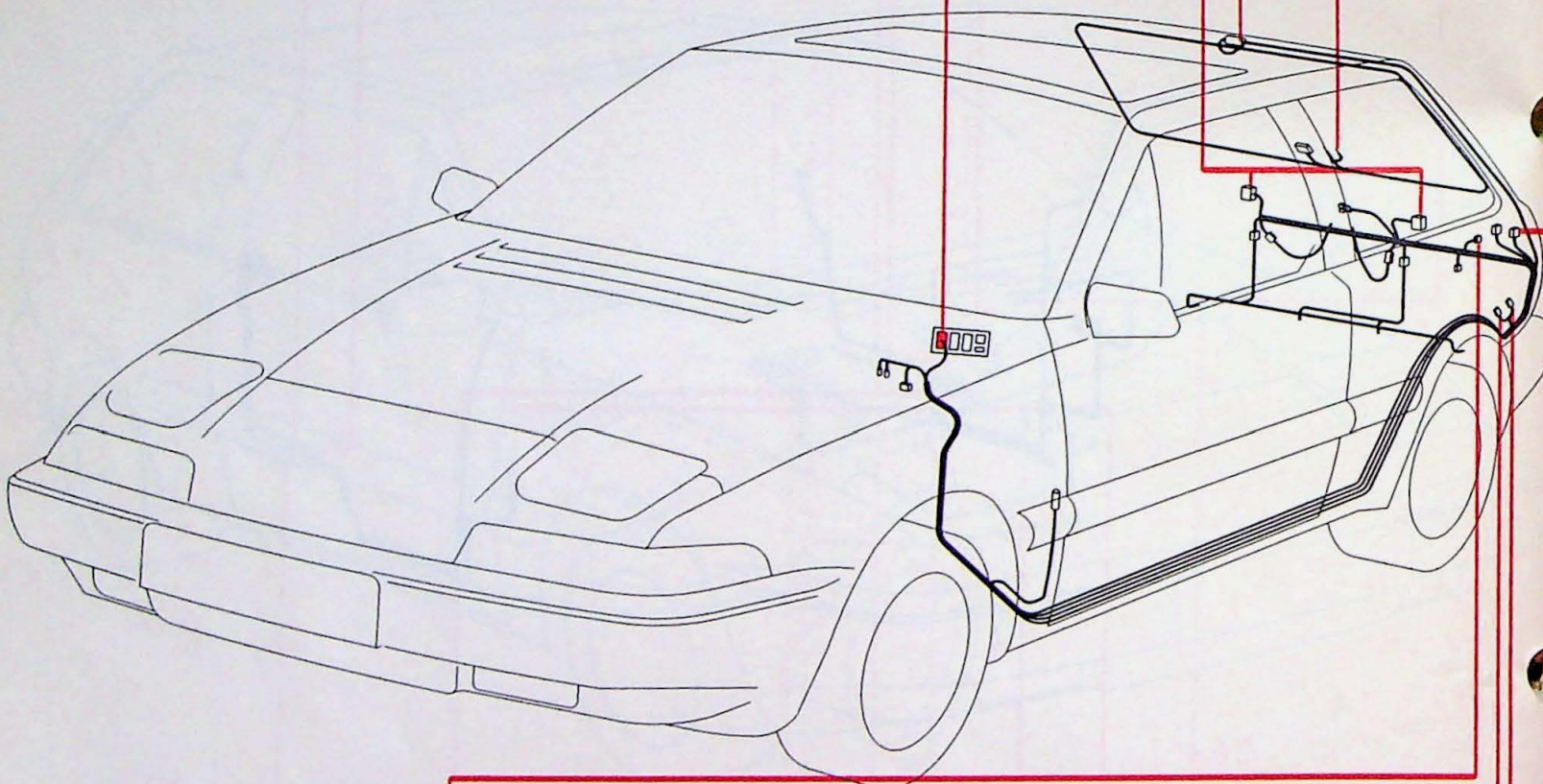

**h10**

h10 → G-H1

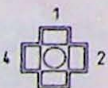

1 = Br
2 = Br
3 = Br
4 = Br

**h2**

h2 → H10

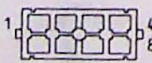

1 = Br-Bl
2 = Br-Bl
3 = Y-Br
4 = Br-Bl
5 = Y-Br
6 = Y-Br
8 = Bl-Y

**h3**

h3 → H10

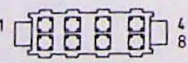

1 = Bl-Y
2 = W-Bl
3 = W-Bl
4 = Br-Gn
5 = Bl-Y
6 = Gr-SB
7 = Br
8 = Bl

**h5**

h5 → H24, H25, H29



1 = R
2 = Gr-R
3 = Br

# Connectoren kabelboom I

L2, L6



- 1 = Br
- 2 = Bl
- 3 = SB
- 4 = Gn
- 5 = Or

L12



- 1 = Bl
- 2 = Gn-Br

L5



- 1 = P
- 2 = SB
- 3 = Br
- 4 = Bl

L3



- 1 = W-SB
- 2 = Br

L13 - L18



- 1 = Gr-R
- 2 = R-Br
- 3 = L
- 4 = Gn
- 5 = Bl-Y
- 6 = W-Bl
- 7 = Gn-R

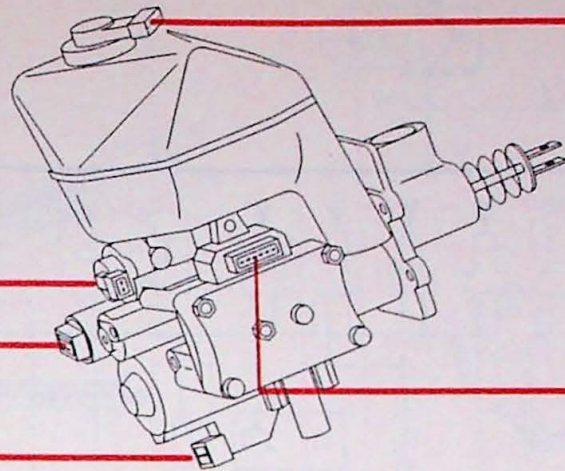

\* = 2x

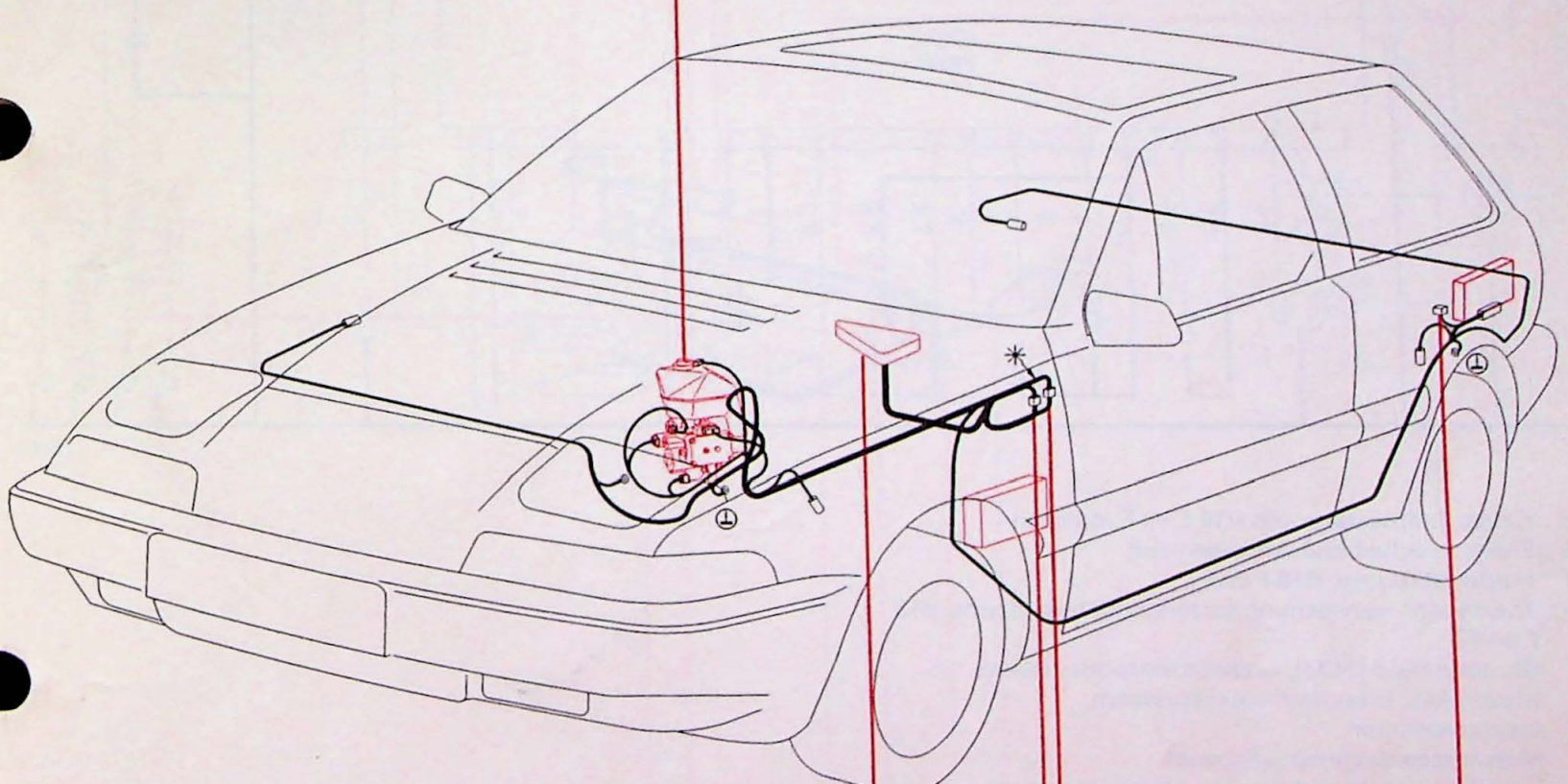

L4

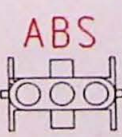
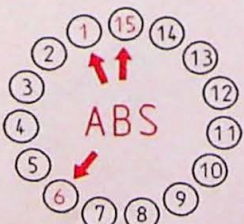

- 1 = Gn
- 2 = Or
- 3 = Gr

- 1 = Gn
- 2 = Or
- 3 = Gr

L2

L2 ↔ c43

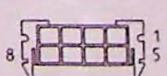

- 1 = Br
- 2 = Gn-Y
- 3 = Or
- 4 = Y
- 5 = Bl-R
- 7 = SB
- 8 = Bl

L3SB

L3SB ↔ c42

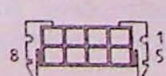

- 1 = Br
- 2 = R
- 3 = W-R
- 4 = W-SB
- 5 = Bl
- 6 = Gr
- 7 = Gn
- 8 = Gn-Br

L7



- 1 = W-Gn
- 2 = Br
- 3 = SB

# Brandstofinspuiting, B18 E motor

30

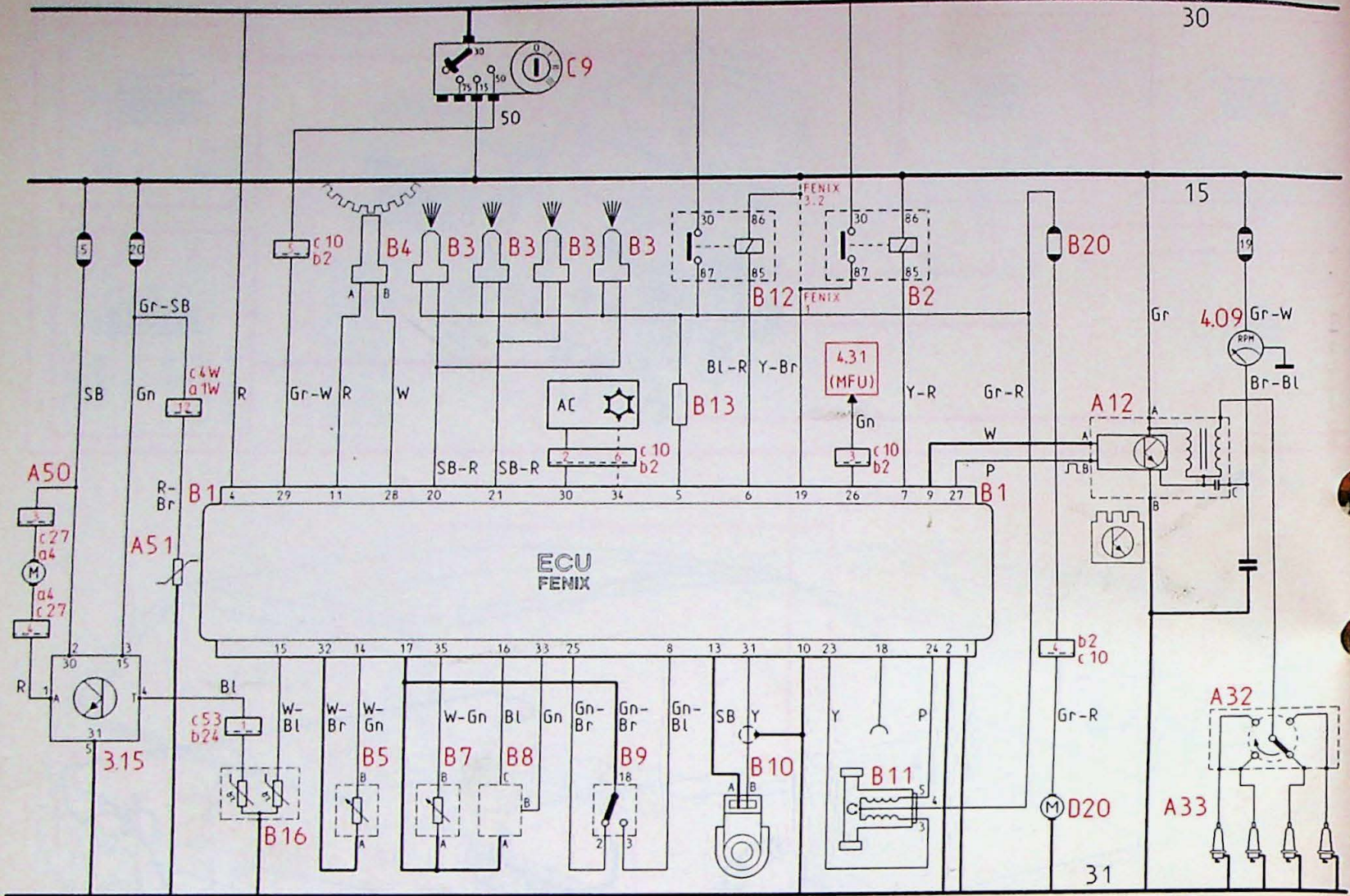

8-013/047

- 3.15 Relais, hulpwaterpomp B18 E en F motoren
- A12 Elektronische ontstekingseenheid
- A50 Hulpwaterpomp, B18 F en FT
- A51 Thermistor, verwarming carterventilatiesysteem, B18 F en FT
- B1 Stuureenheid (ECU), brandstofinspuitsysteem
- B2 Stuurrelais, brandstofinspuitsysteem
- B3 Inspuitventielen
- B4 Motortoerentalgever, vliegwiel
- B5 Inlaatlucht-temperatuurgever, inspuitsysteem
- B7 Potentiometer, CO-afstelling
- B8 Luchtdrukgever, inspuitsysteem
- B9 Smoorklepschakelaar
- B10 Pingelsensor
- B11 Regelklep, stationair toerental
- B12 Brandstofpomprelais
- B16 Koelvloeistof-temperatuurgever, inspuitsysteem en hulpwaterpomp of (B18 FT) ontstekingseenheid
- B19 Zekering (naast B2), Zuurstofsensoren, B18 F en FT
- B20 Zekering (naast B12), Brandstofpomp, B18 F en FT
- D20 Brandstofpomp, brandstof-inspuitsysteem

# Brandstofinspuiting, B18 E motor

**B10**



SB  
Y

**B1**

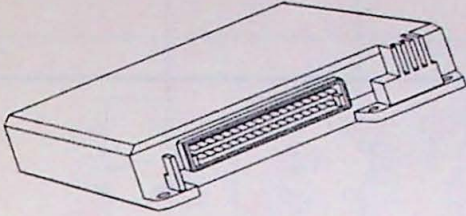
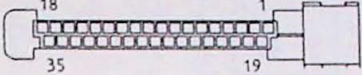



**B12**



30=R  
85=Bl-R  
86=Y-Br  
87=Gr-R

**B2**



30=R  
85=Y-R  
86=Gr  
87=Y-Br

**B8**

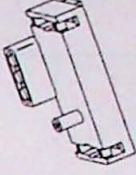

Br  
Gn  
Bl

**B11**

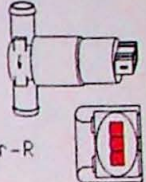

1 = Y  
2 = Gr-R  
3 = P

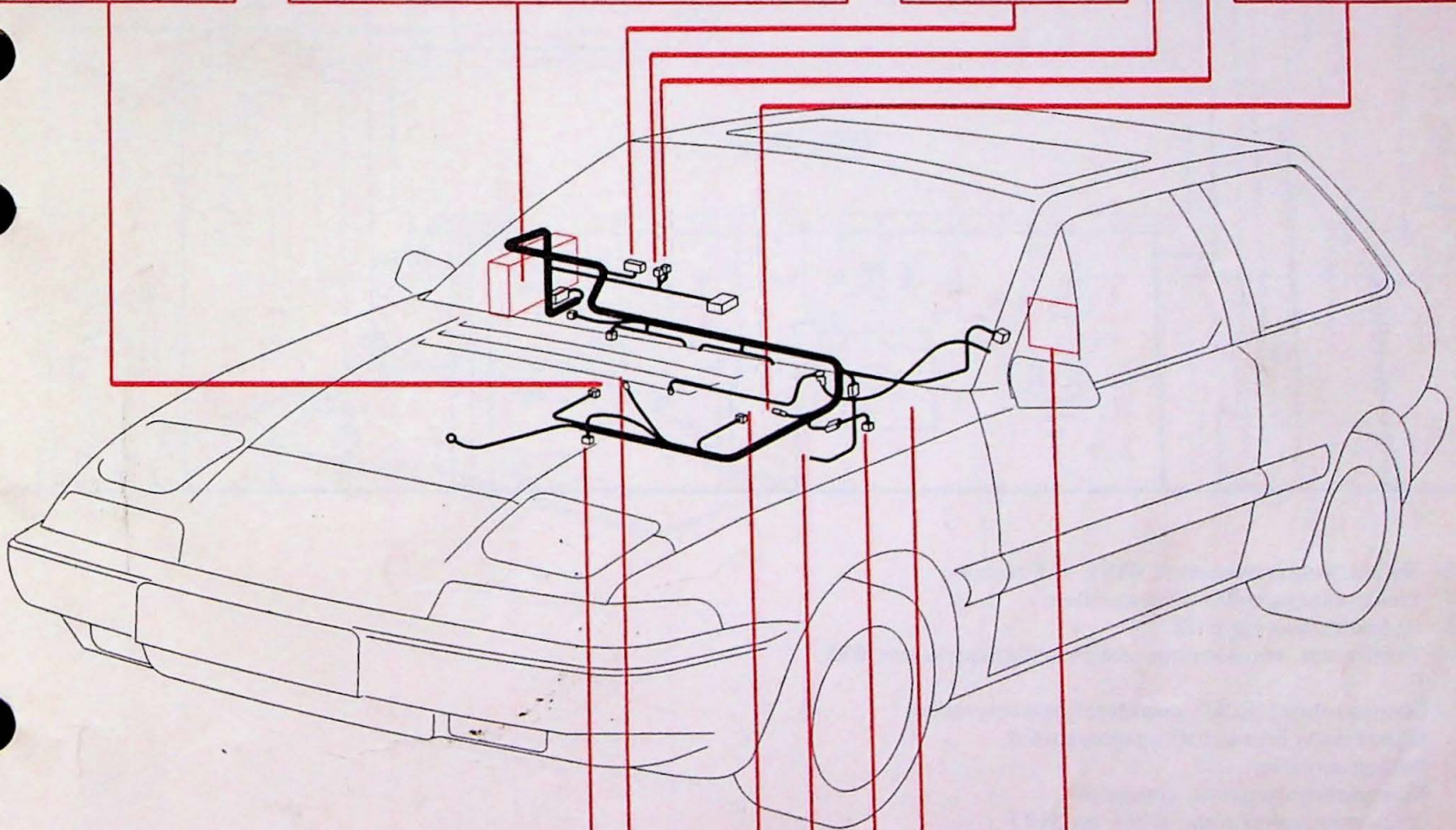

**B5**

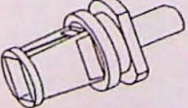

W-Gn  
W-Br

**B9**

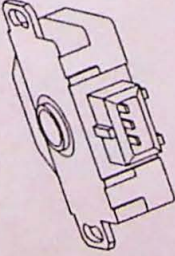

Gn-Br  
Gn-Br  
Gn-Bl

**B16**

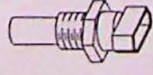

W-Bl  
W-Bl

**A51**



R-Br

**A12**

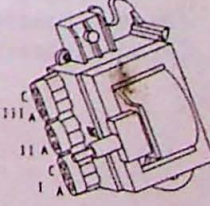

<I>  
A = Gr  
B = Br  
C = Br-Bl

<II>  
A = W  
B = P

**B4**

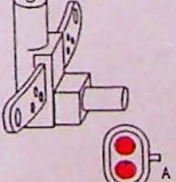

R  
W

**B7**

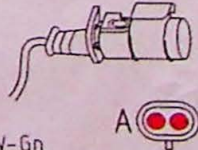

W-Gn  
Gn-Br

A

# Brandstofinspuiting, B18 F motor

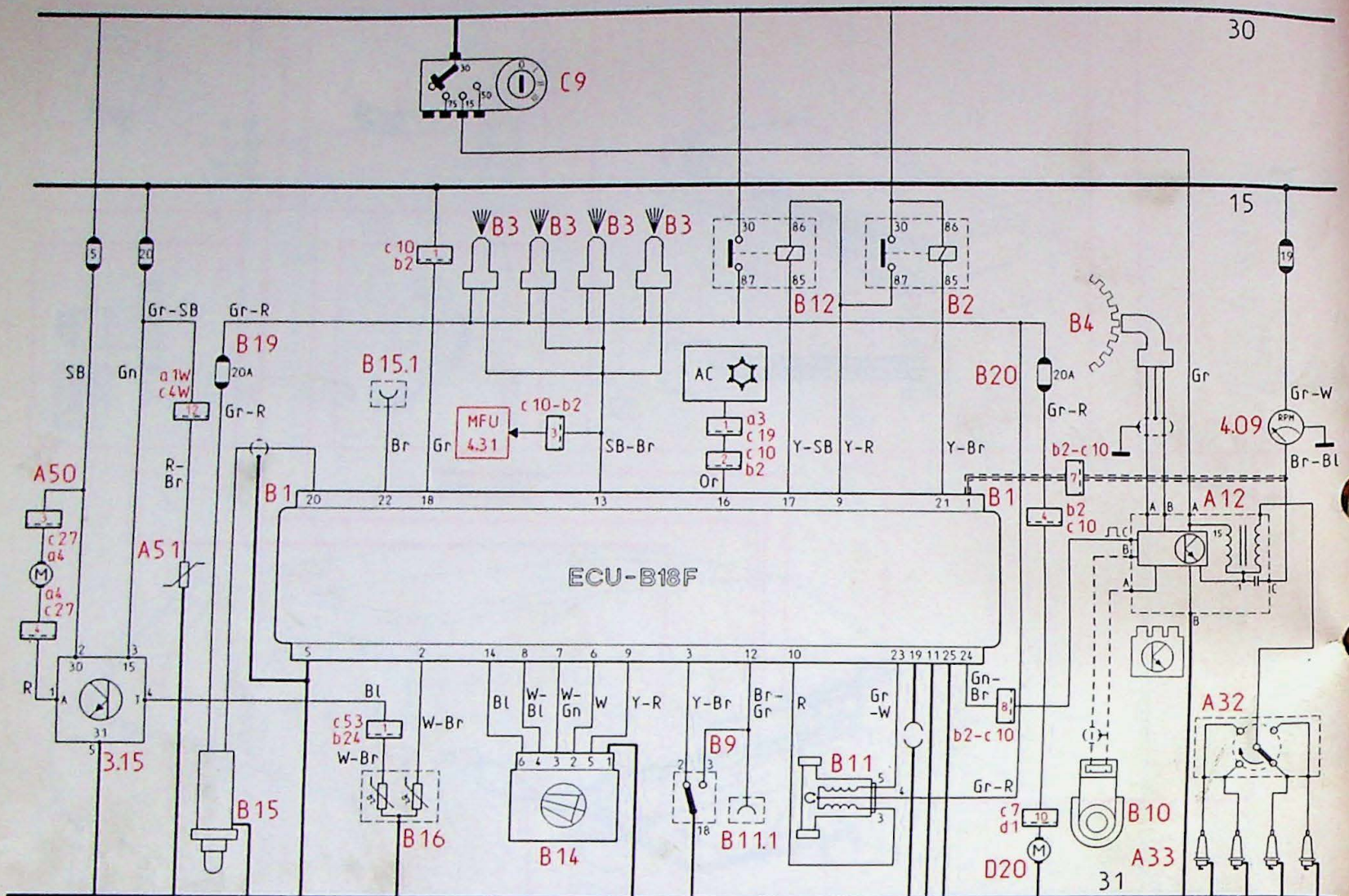

8-013/046

- 3.15 Relais, hulpwaterpomp, B18 F + E motor
- A12 Elektronische ontstekingsseenheid
- A50 Hulpwaterpomp, B18F
- A51 Thermistor, verwarming carterventilatiesysteem, B18 F
- B1 Stuurseenheid (ECU), brandstofinspuitstelsysteem
- B2 Stuurrelais, brandstofinspuitstelsysteem
- B3 Insputventielen
- B4 Motortoerentalgever, vliegwiel
- B9 Smoorklepschakelaar, B18 E en B18 F
- B10 Pingelsensor
- B11 Regelklep, stationair toerental
- B12 Brandstofpomprelais
- B14 Luchtmassa-meter, B18 F en FT
- B15 Zuurstofsensoren, B18 F en FT
- B16 Koelvloeistof-temperatuurgever, hulpwaterpomp en inspuitstelsysteem B18 F
- B19 Zekering (naast B2), Zuurstofsensoren, B18 F
- B20 Zekering (naast B12), Brandstofpomp, B18 F

# Brandstofinspuiting, B18 F motor

b14 → B1

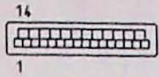

1 = --	8 = W-BL	15 = --	22 = Br
2 = W-Br	9 = Y-R	16 = Or	23 = Gr-W
3 = Y-Br	10 = P	17 = Y-SB	24 = Gn-Br
4 = --	11 = --	18 = Gr	25 = Br
5 = Br	12 = Br-Gr	19 = Br	
6 = W	13 = SB-Br	20 = --	
7 = W-Gn	14 = Bl	21 = Y-Br	

B2, B12

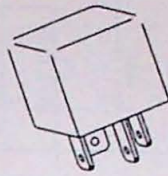

30 = R  
85 = Y-Br  
86 = R  
87 = Y-R

B16



W-Br  
W-Br

A50

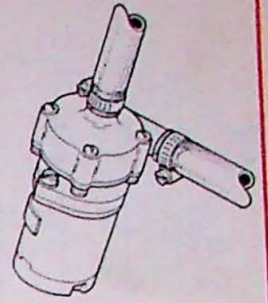

SB  
R

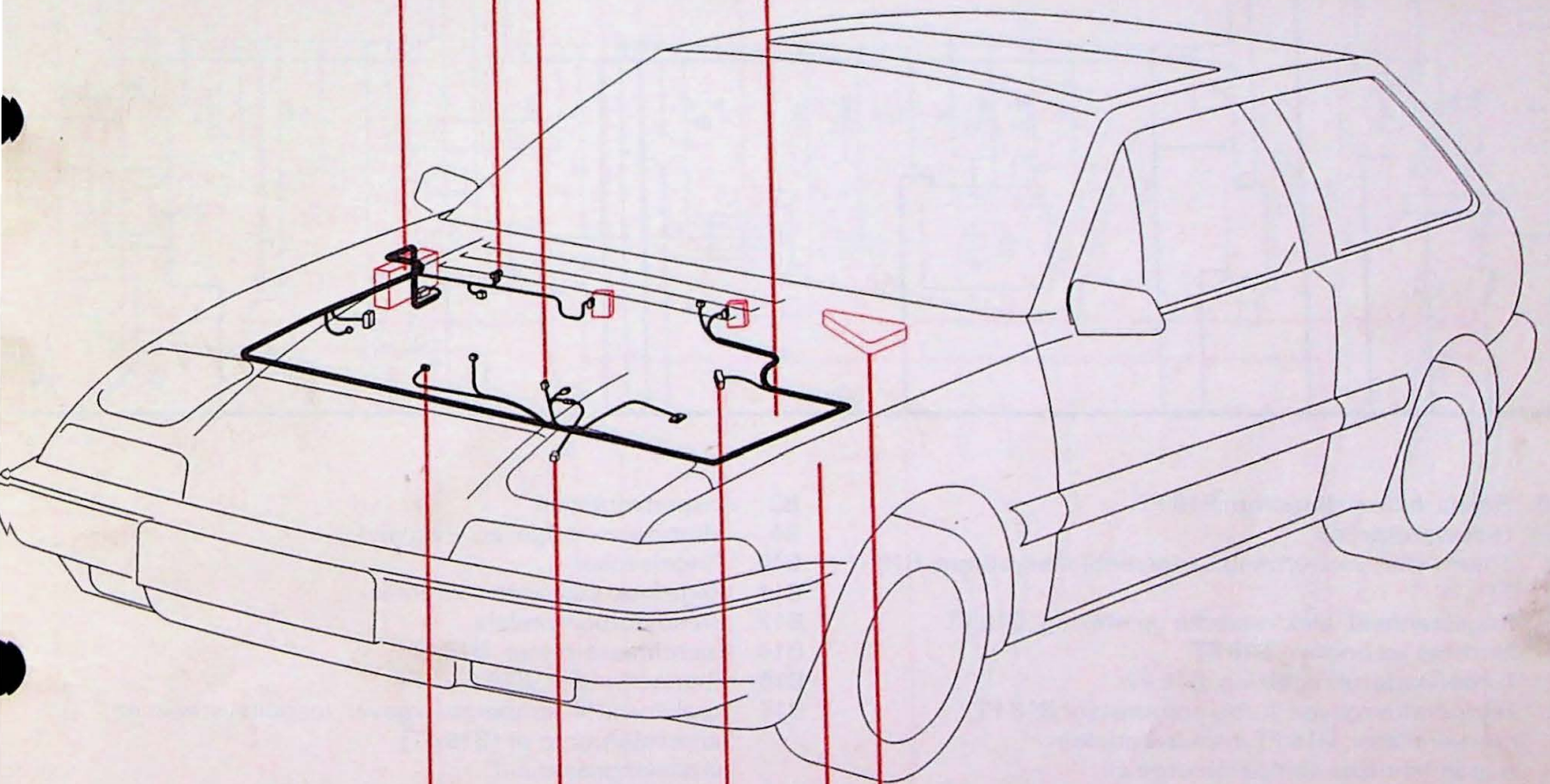

#11

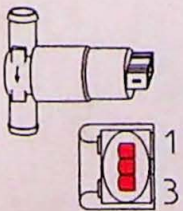

1 = Gr-W  
2 = R  
3 = Gr-R

A51

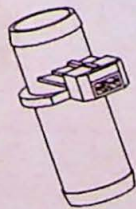

R-Br  
Br

B14

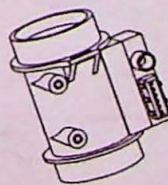

1 = Br  
2 = W  
3 = W-Gn  
4 = W-Bl  
5 = Y-R  
6 = Bl

B15

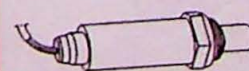

3.15

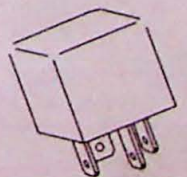

A = R  
T = Gr-W  
15 = Gn  
30 = SB  
31 = Br

# Brandstofinspuiting B18 FT motor

30

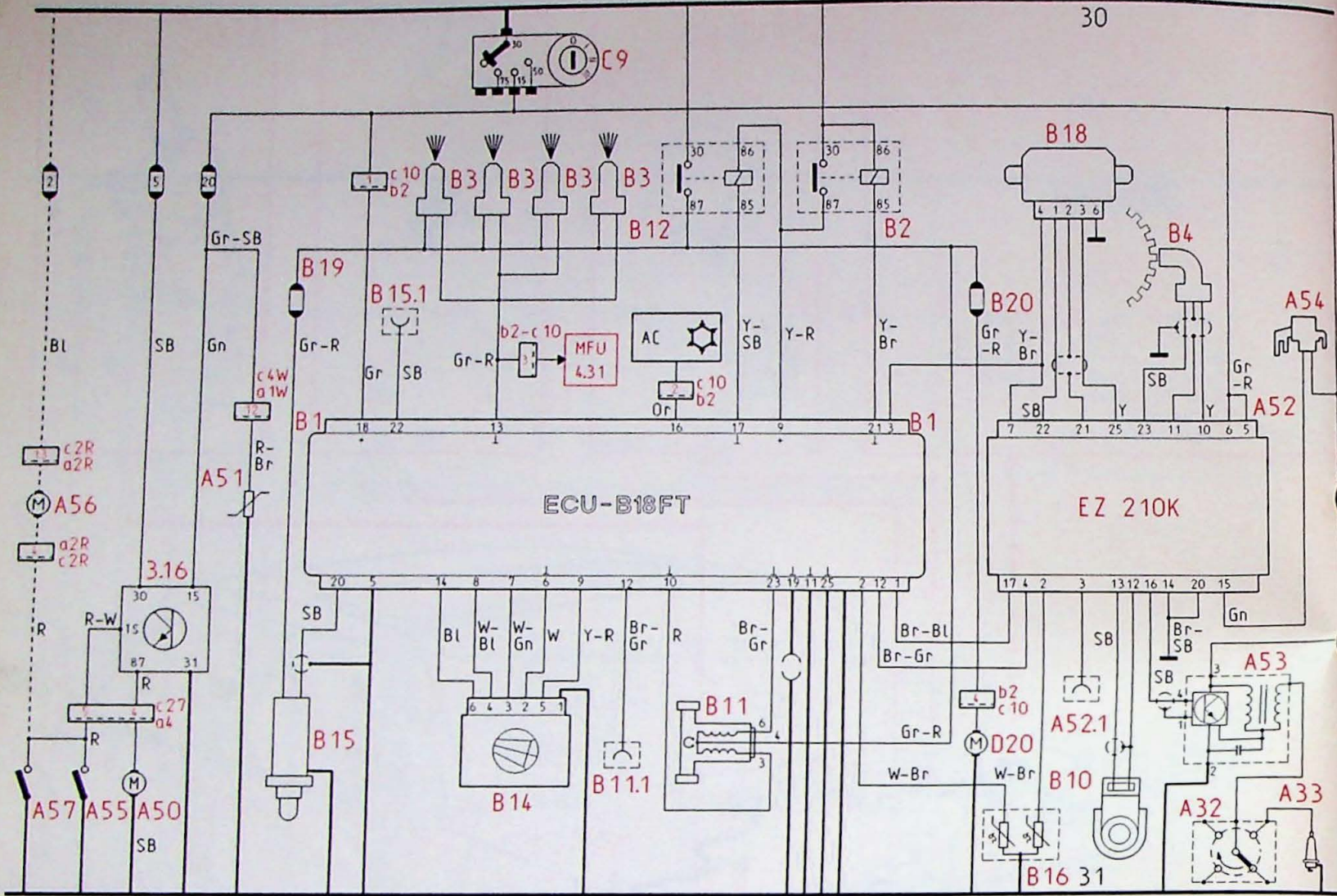

8-013/061

- |      |  |     |  |
|------|--|-----|--|
| 3.16 | Relais, hulpwaterpomp, B18 FT                          | B3  | Inspuitventielen   |
| A50  | Hulpwaterpomp  | B4  | Motortoerentalgever, vliegwiel   |
| A51  | Thermistor, verwarming carterventilatiesysteem, B18 FT | B10 | Pingsensor   |
| A52  | Regeleenheid, elektronische ontsteking, B18 FT         | B11 | Regelklep stationair toerental   |
| A53  | Eindtrap en bobine, B18 FT                             | B12 | Brandstofpomprelais  |
| A54  | Turbo-laaddrukregelklep, B18 FT                        | B14 | Luchtmassa-meter, B18 FT   |
| A55  | Temperatuurgever, turbo-compressor B18 FT              | B15 | Zuurstofsensor, B18 F en FT  |
| A56  | Koelventilator, B18 FT inspuitventielen                | B16 | Koelvloeistof-temperatuurgever, inspuitsysteem en hulpwaterpomp of (B18 FT) ontstekingseenheid |
| A57  | Inspuitventielen-temperatuurgever                      | B18 | Smoorklepschakelaar en klepstandsensoren, B18 FT   |
| B1   | Stuureenheid (ECU), brandstofinspuitsysteem            | B19 | Zekering (naast B2), zuurstofsensor  |
| B2   | Stuurrelais, brandstofinspuitsysteem                   |     |  |

# Brandstofinspuiting B18 FT motor

**B16**

W-Br  
W-Br  
Br



**B1**

b14 → B1

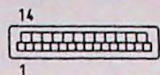

1 = Br-Bl	8 = W-Bl	15 = --	22 = SB
2 = W-Br	9 = Y-R	16 = Or	23 = Br-Gr
3 = Y-Br	10 = R	17 = Y-SB	24 = Gn-Br
4 = --	11 = Br	18 = Gr	25 = Br
5 = Br	12 = Br-Gr	19 = Br	
6 = W	13 = Gr-R	20 = SB	
7 = W-Gn	14 = Bl	21 = Y-Br	

**A52**

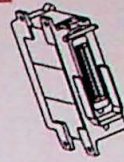

1 = --	14 = Br-SB
2 = W-Br	15 = Gn
3 = --	16 = SB
4 = Br-Gr	17 = Br-Bl
5 = R	18 = Y-R
6 = Gr	19 = Y-SB
7 = Y-Br	20 = Br
8 = --	21 = L
9 = --	22 = SB
10 = Y	23 = SB
11 = L	24 = --
12 = L	25 = Y
13 = SB	

**A54**

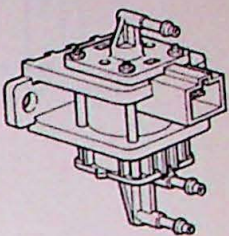

Gn  
Gr

**B10**

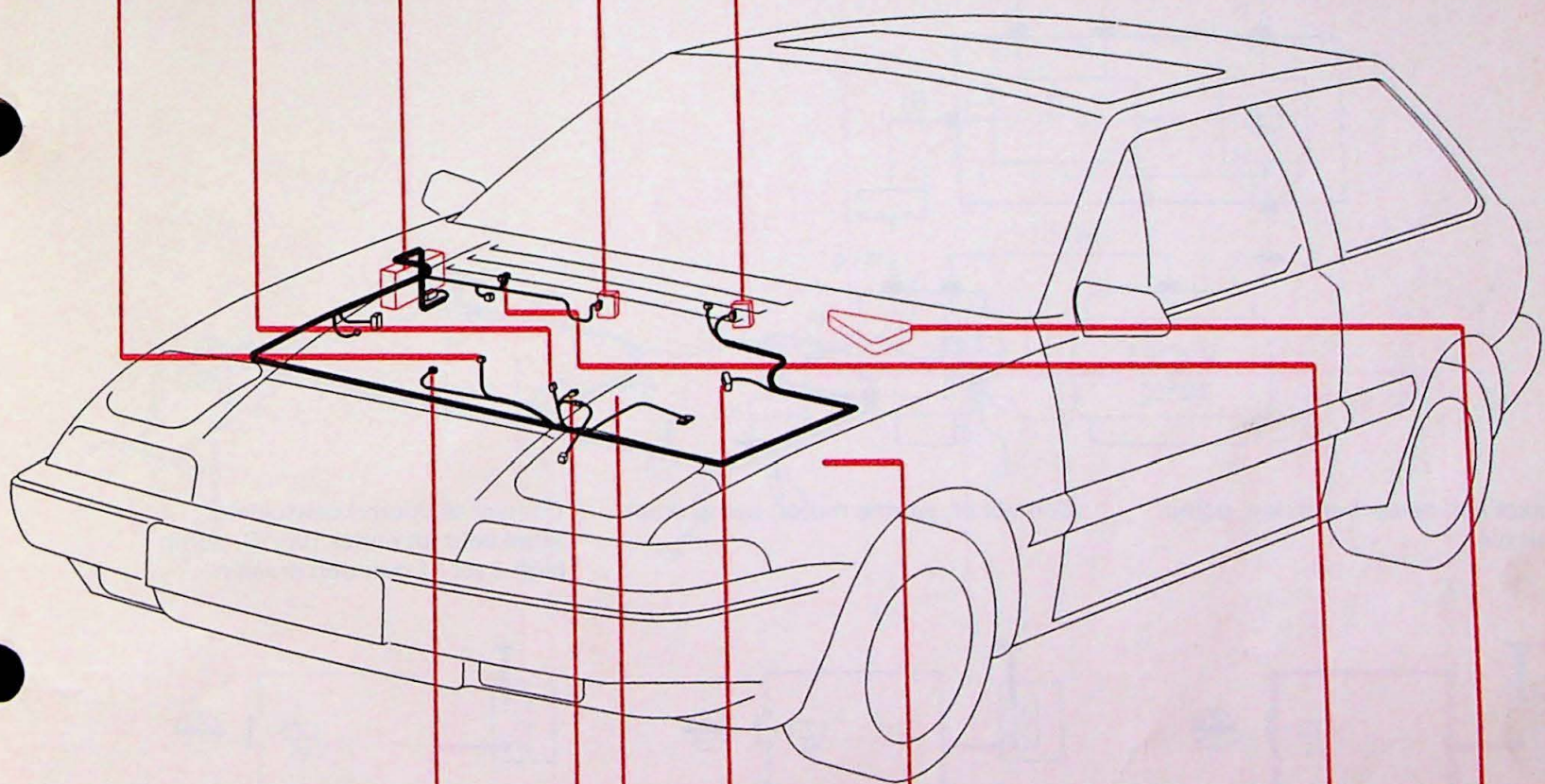

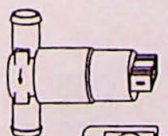
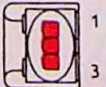

**B11**



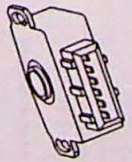

1 = R
2 = Gr-R
3 = Br-Gr

**B18**



**B14**



**A51**



R-Br  
Br

**3.16**

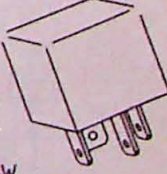

31 = Br  
30 = SB  
15 = Gn  
87 = R  
TS = R-W

**A55**

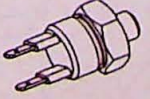

R  
Br

**B15**

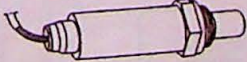

**A57**

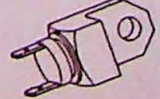

R  
Br

**B2, B12**

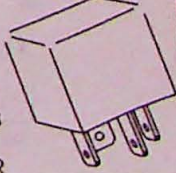

30 = R  
85 = Y-SB  
86 = Y-R  
87 = GR-R

# Hulpwaterpomp, B18 E en F motoren

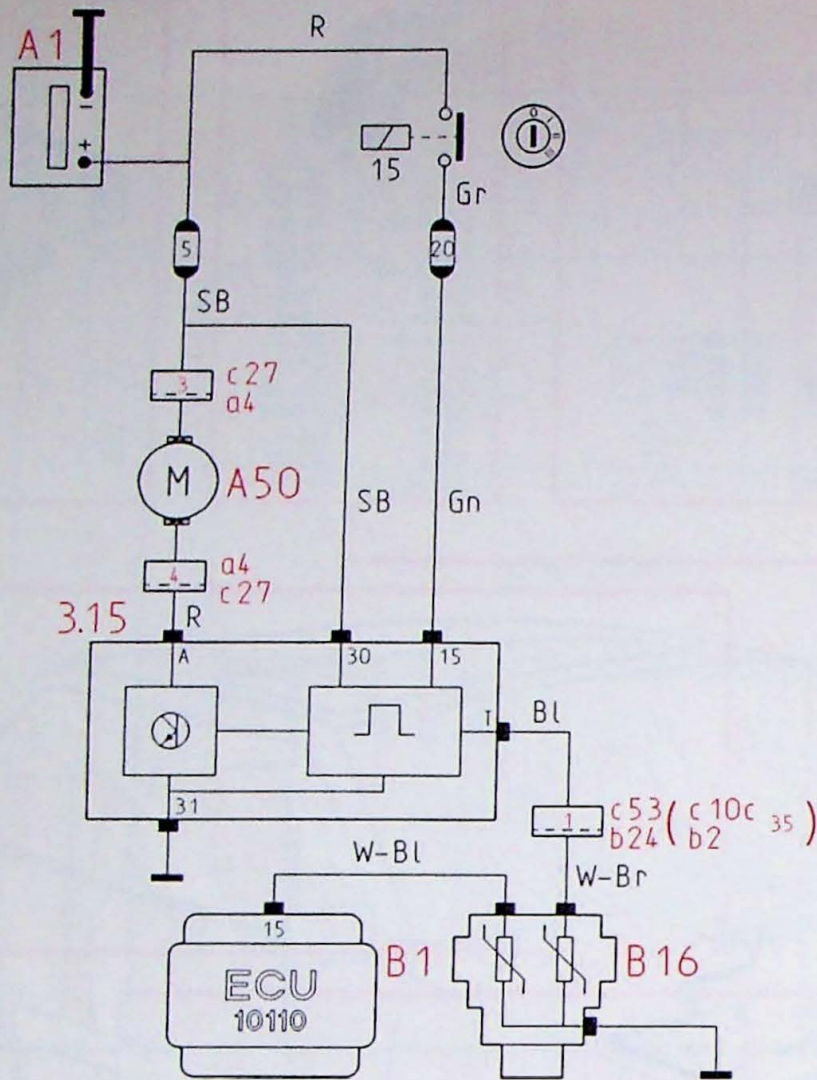

- 3.15 Relais, hulpwaterpomp
- A50 Hulpwaterpomp
- B1 Stuurseenheid (ECU), brandstofinspuitsysteem
- B16 Koelvloeistof-temperatuurgever, hulpwaterpomp

Contact aan onder het rijden, pomp draait niet

Contact af, warme motor, pomp draait

Contact af, motorkoelvloeistof afgekoeld tot onder 100 °C, pomp blijft 8 tot 11 minuten draaien.

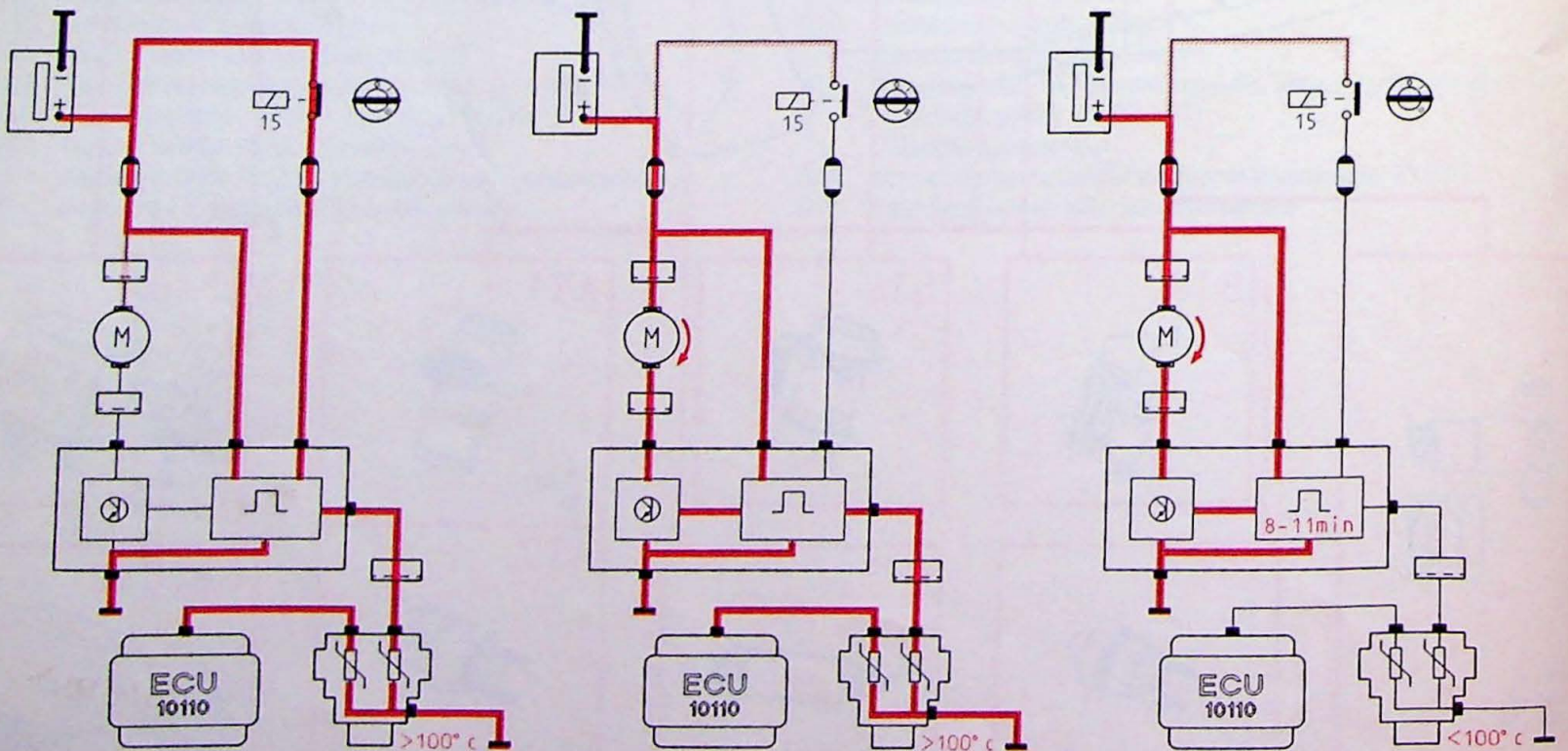

8-013/04.8

# Hulpwaterpomp, B18 E en F motoren

B1

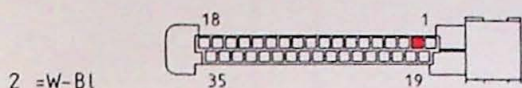
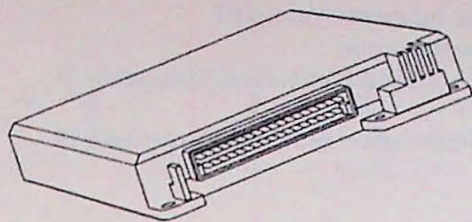

2 = W-Bl

3.0

3.15

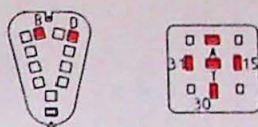

B = 1987-1988  
D = 1988-1989

A = R            30 = SB  
T = Bl (Gr-W)   31 = Br  
15 = Gn (Gr-W)

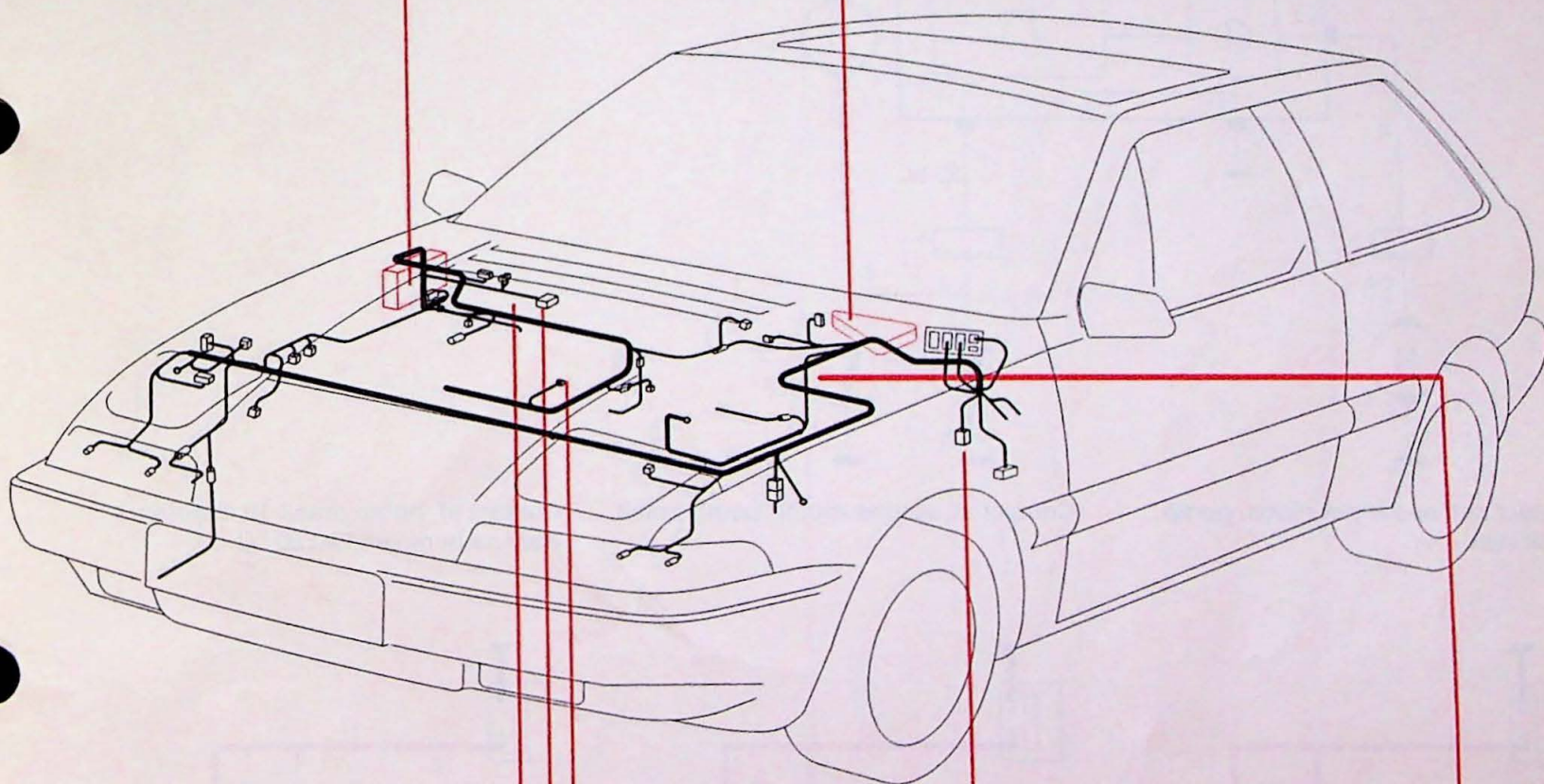

c53

c53 ↔ b24



Bl ↔ W-Br

c10(c)

c10(c) ↔ b2(c)

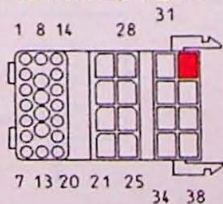

35 = Gr-W ↔ W-Br

B16



W-Br  
W-Bl

c27

c27 → A4

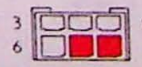

EURO            GB  
4 = R            4 = SB  
5 = SB           5 = R

A50

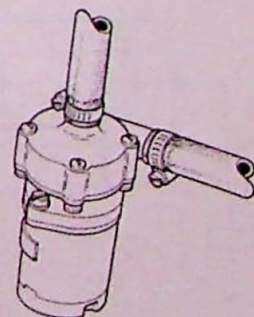

# Hulpwaterpomp, B18 FT motoren

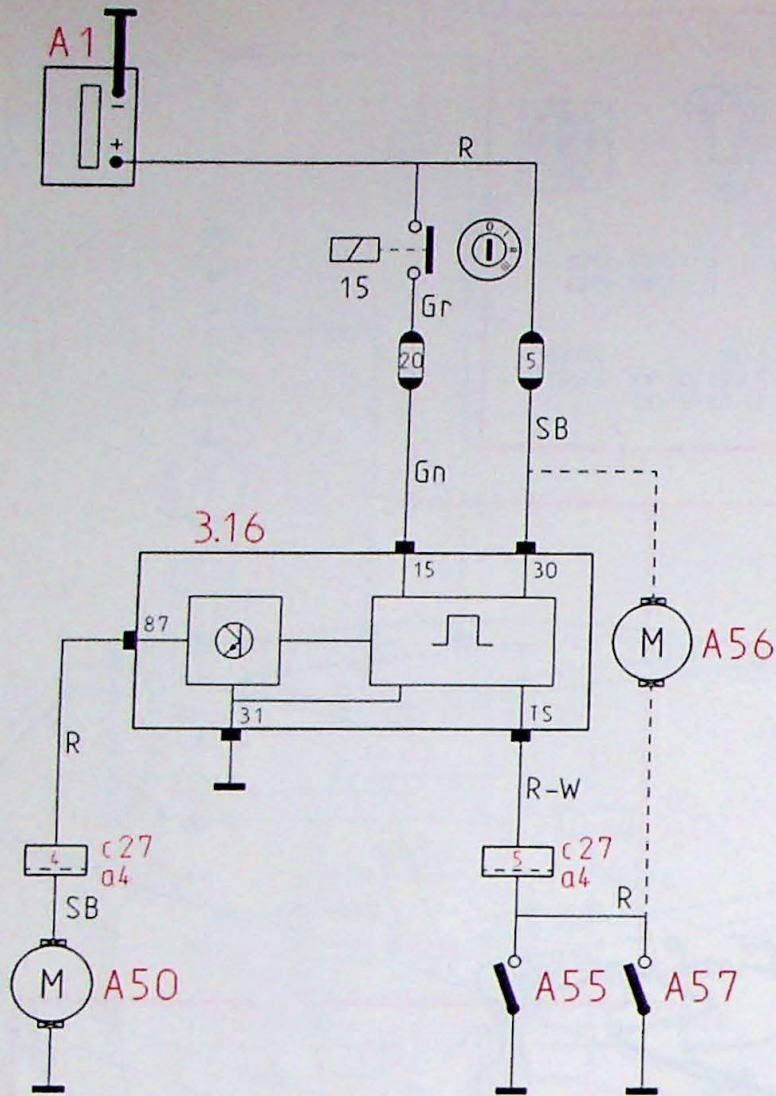

- 3.16 Relais, hulpwaterpomp FT
- A50 Hulpwaterpomp
- A55 Temperatuurgever turbocompressor B18 FT
- A57 Inspuitventielen temperatuurgever B18 FT

Contact aan onder het rijden, pomp draait niet

Contact af, warme motor, pomp draait

Contact af, pomp draait 10 minuten door na bereiken van 90 °C

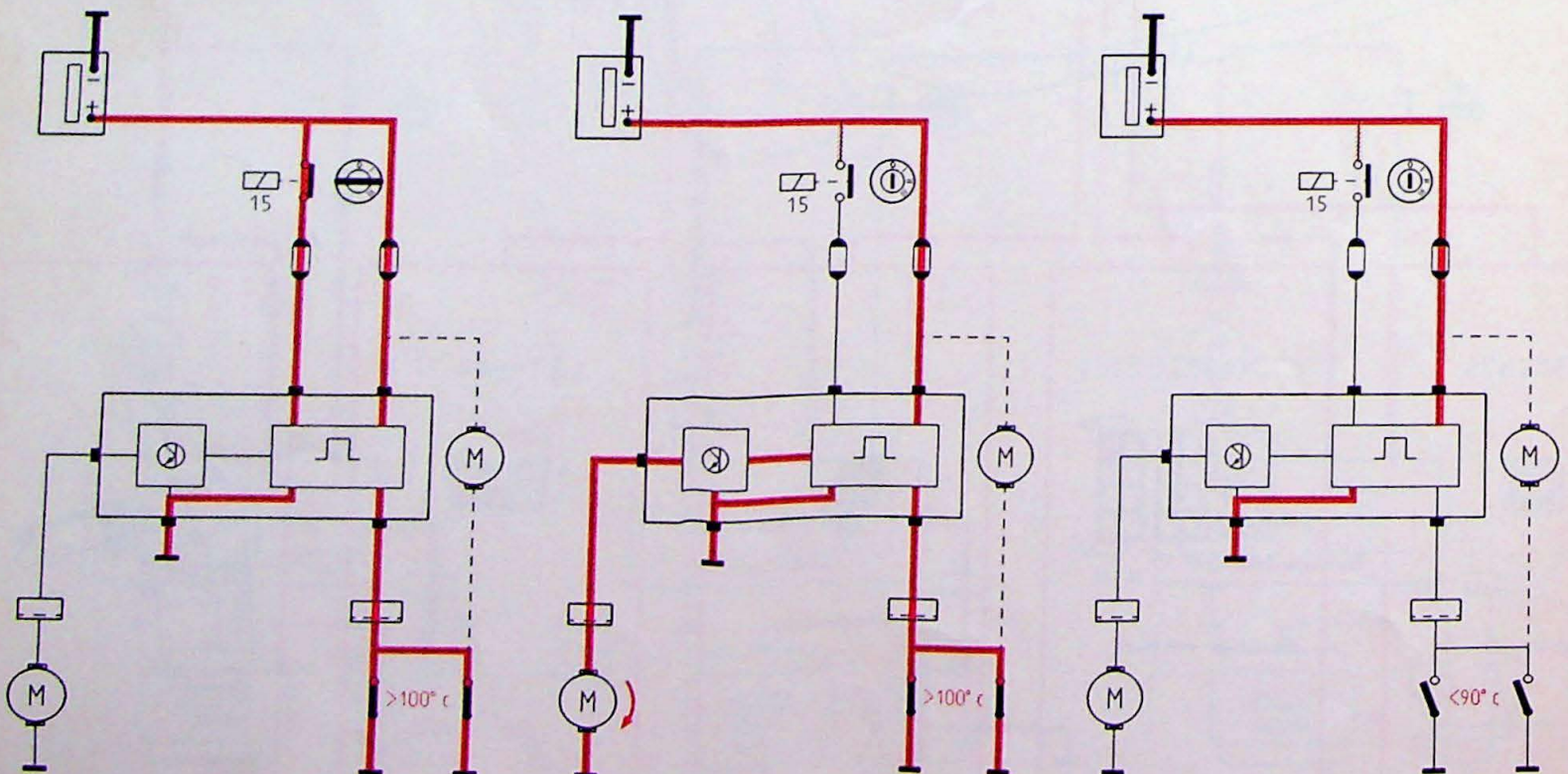

8-013/071

# Hulpwaterpomp, B18 FT motoren

A55

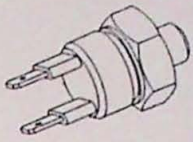

A57

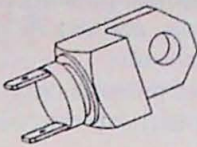

3.0

3.16

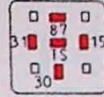

B = 1987-1988  
D = 1988-1989

15=R      31=BR  
15=SB      87=R  
30=Gn

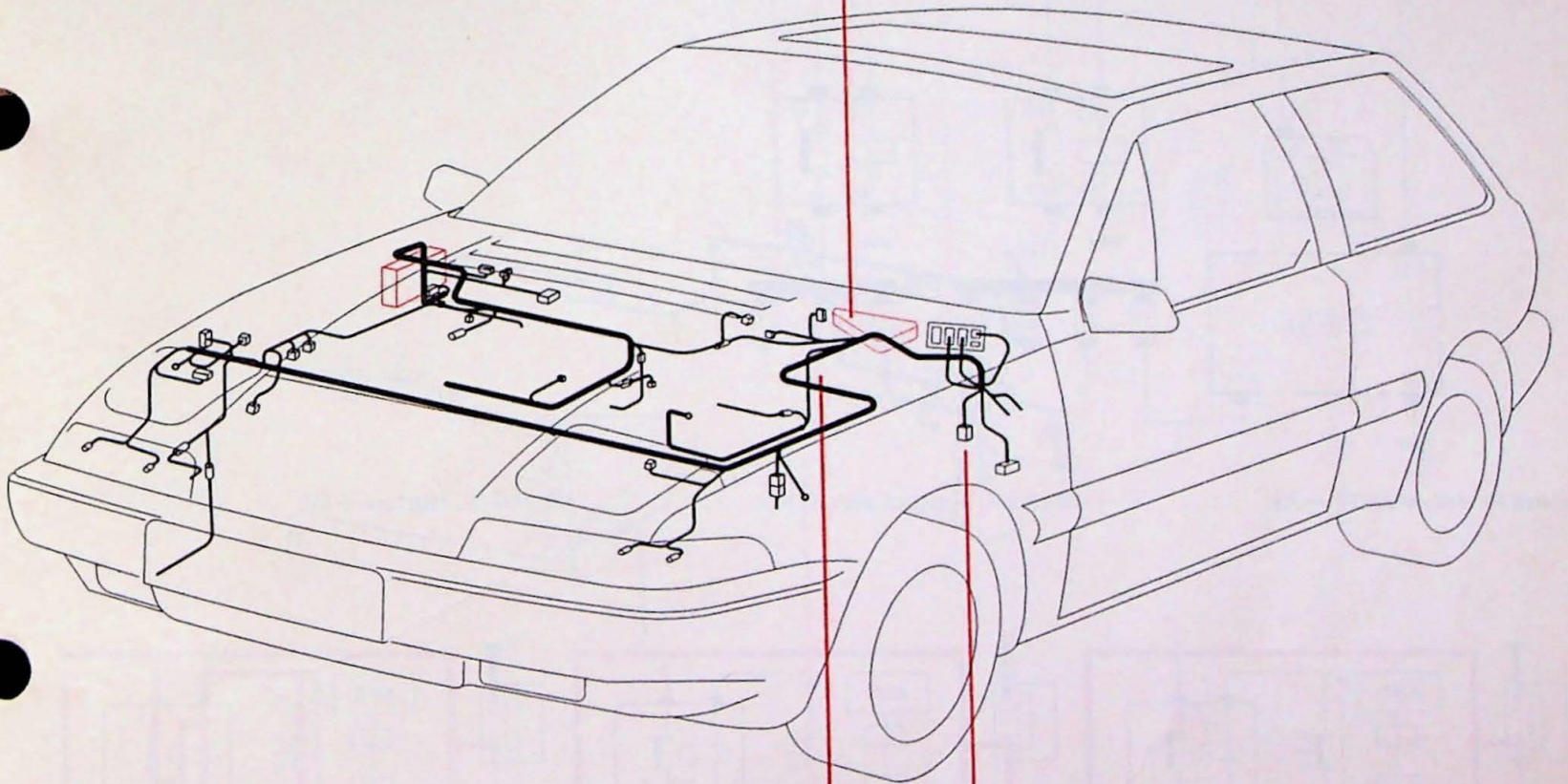

A50

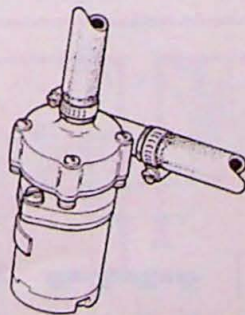

c27

c27 → A4

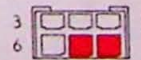

4 = R  
5 = R-W

# Contact-/startschakelaar

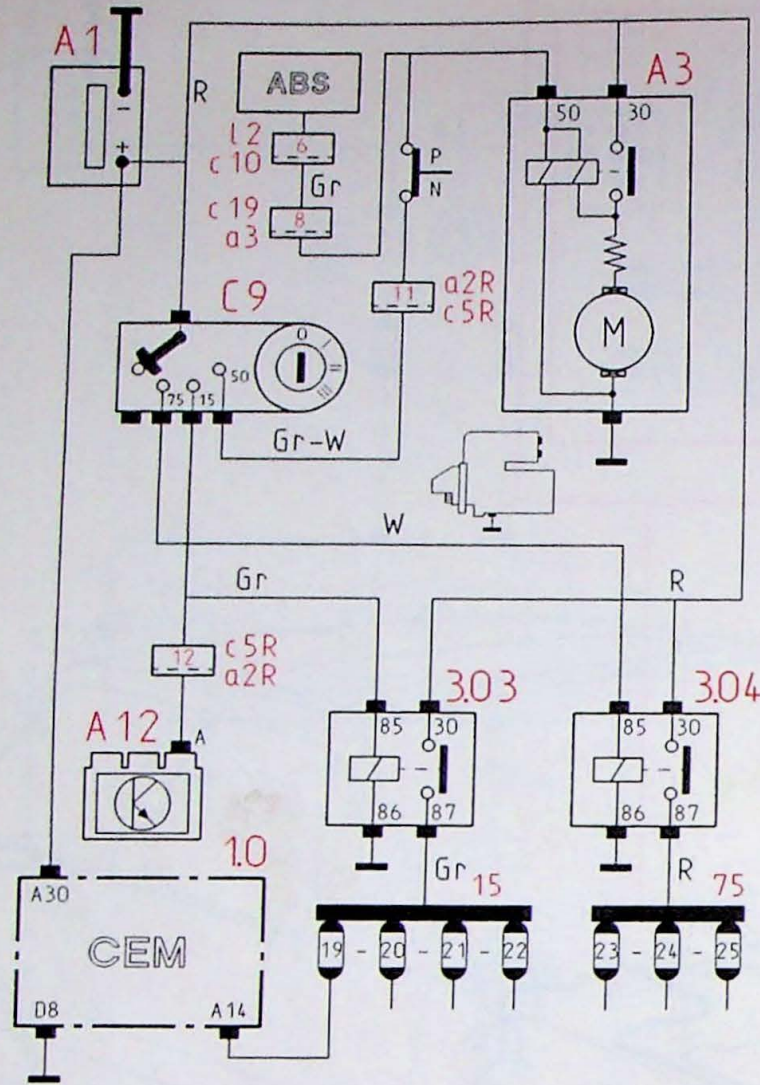

- 1.0 CEM
- 3.03 Ontstekingsrelais (contact 15)
- 3.04 Relais, contact 75
- A3 Startmotor
- A12 Elektronische ontstekingseenheid
- C9 Contact-/startschakelaar

Sleutel in slot, stand I +75

Stand II, contact aan +15

Stand III, starten +50

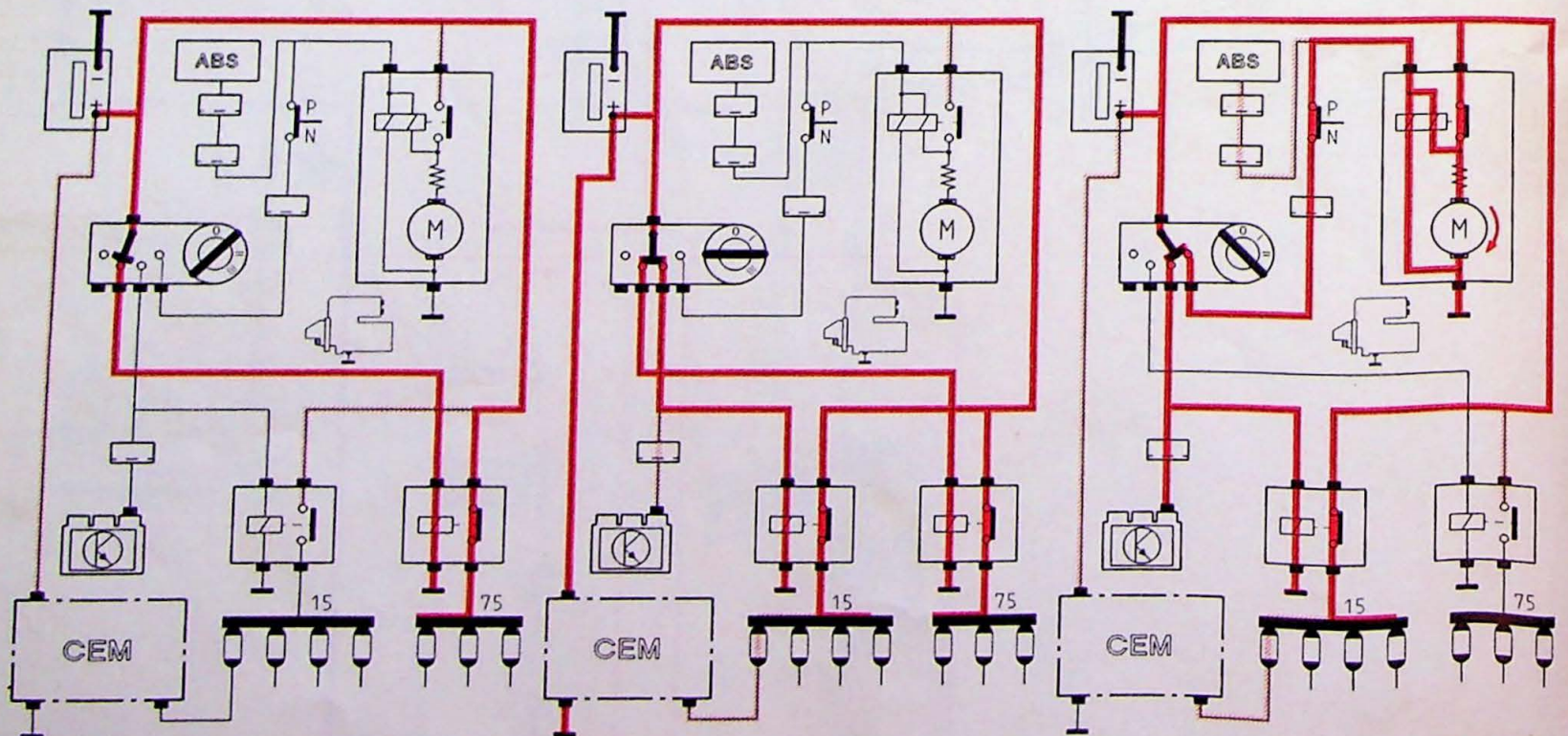

8-013/016

# Contact-/startschakelaar

A12

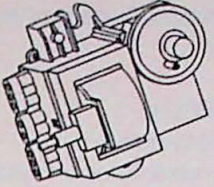

<A>  
A =Gr

3.0

3.03

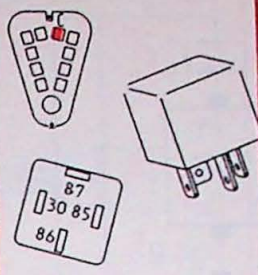

3.04

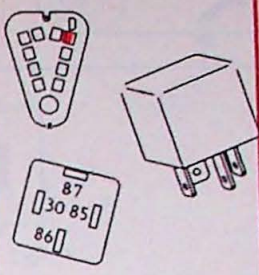

c5R

c5R ↔ a2R

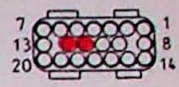

11=Gr-W  
12=Gr

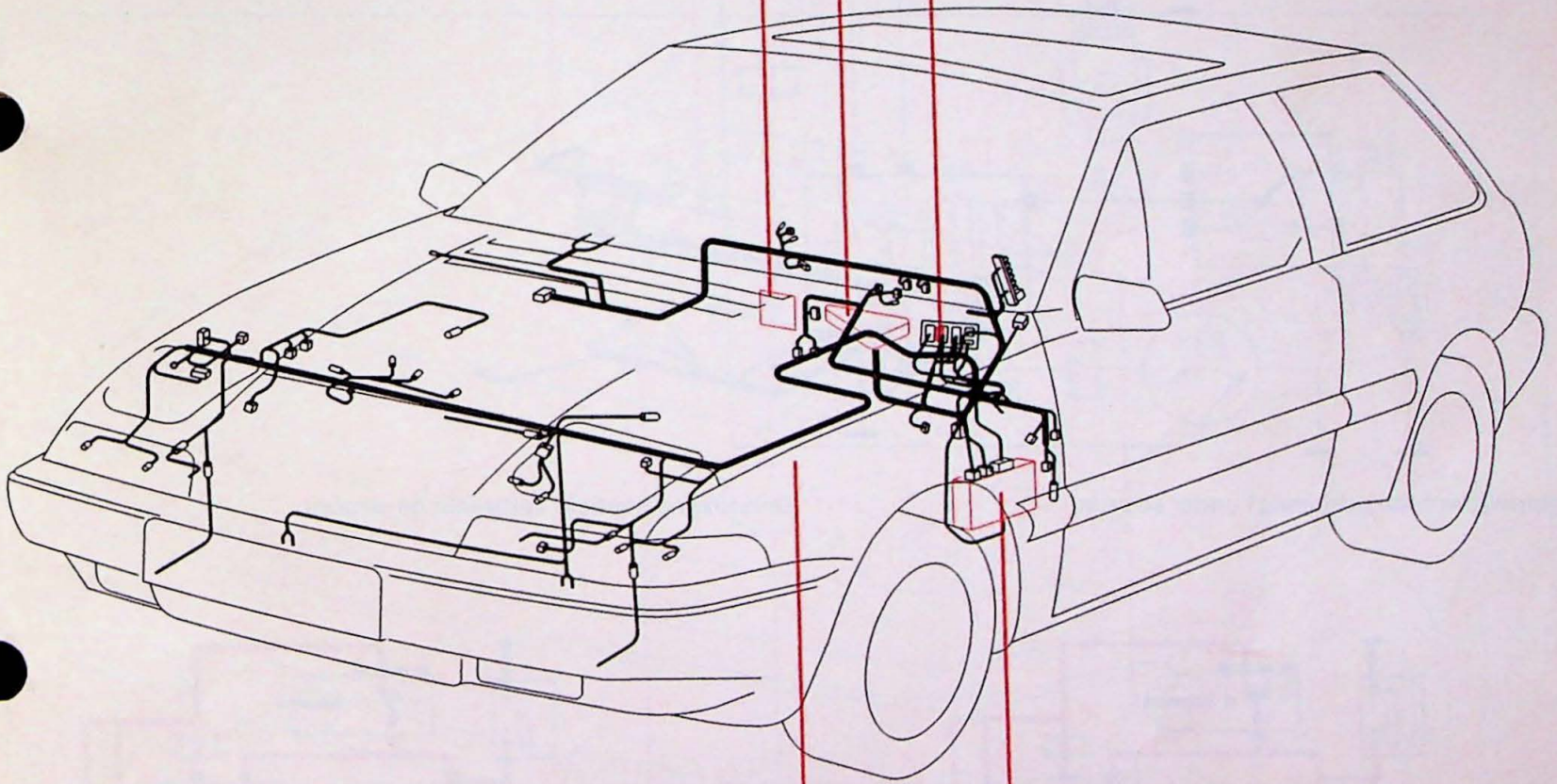

A3

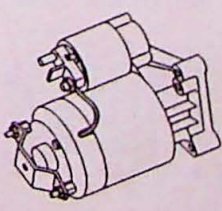

1.0

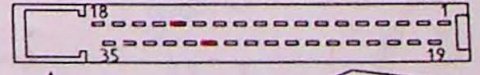

A

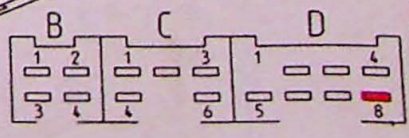

B C D

A14=Gr-W  
A30=R  
D8 =Br

# Elektronische ontsteking B18 E motoren

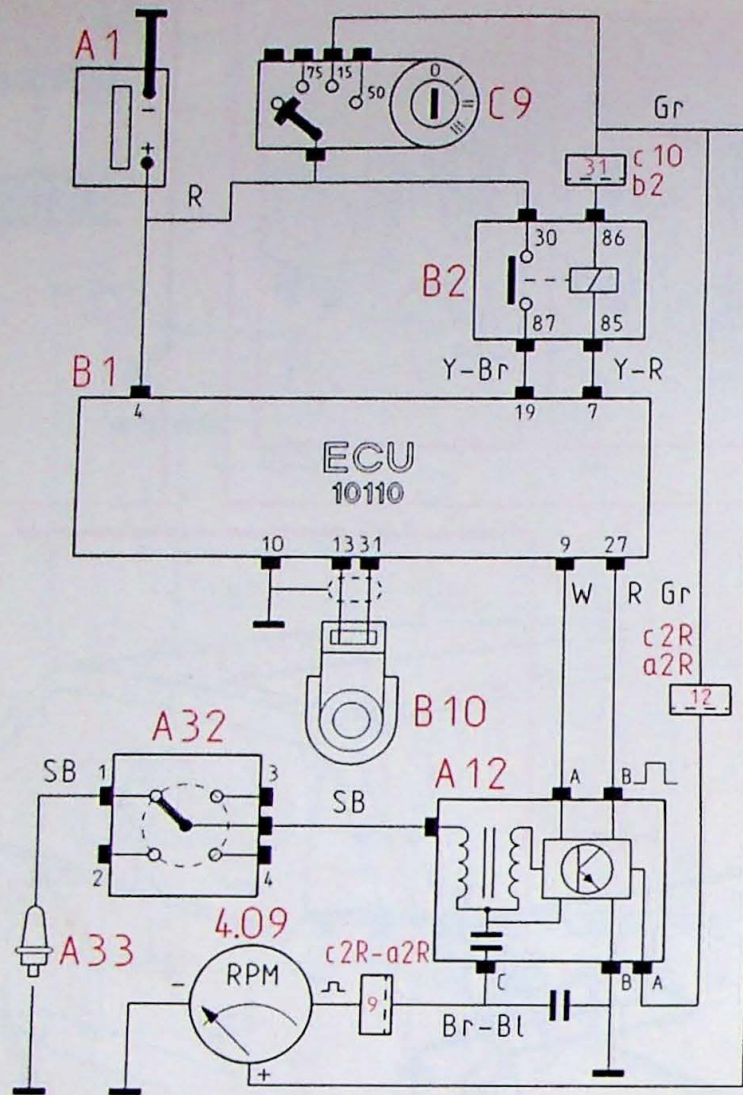

- 4.09 Toerenteller
- A12 Elektronische ontstekingseenheid
- A32 Stroomverdeler
- A33 Bougies
- B1 Stuureenheid (ECU), brandstofinspuitsysteem
- B2 Stuurrelais, brandstofinspuitsysteem
- B9 Smooklepschakelaar
- B10 Pingelsensor

Bobine (primaire wikkeling) onder stroom

Ontstekingseenheid verbreekt de stroom

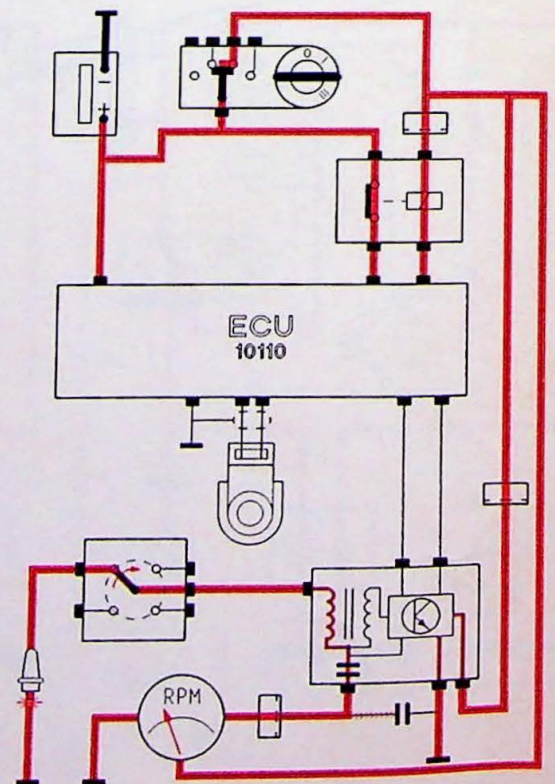
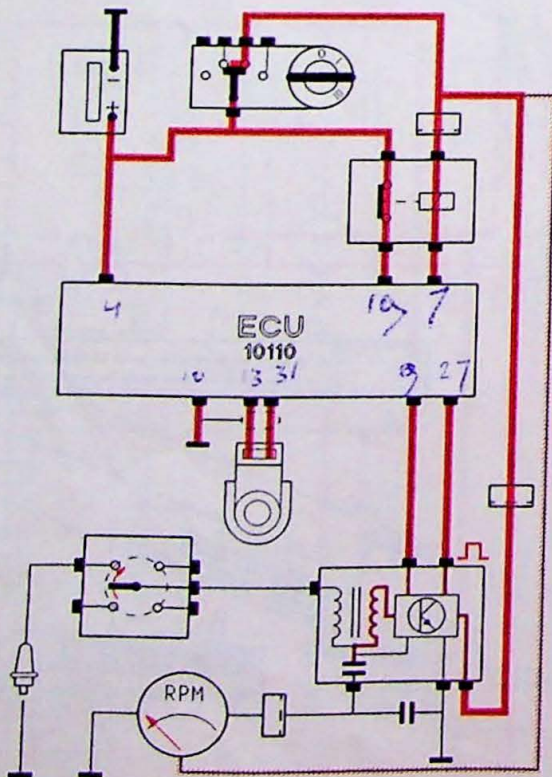

8-013/040

# Elektronische ontsteking B18 E motoren

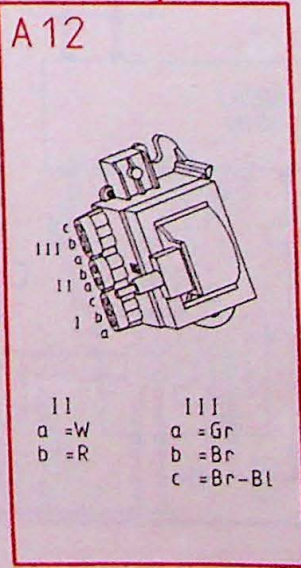
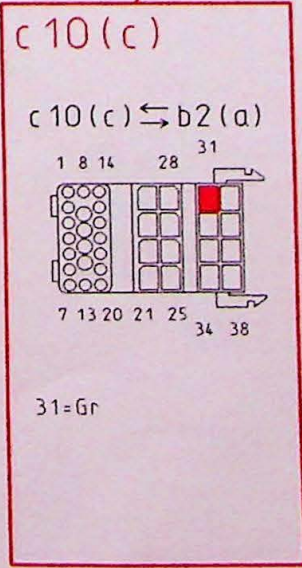
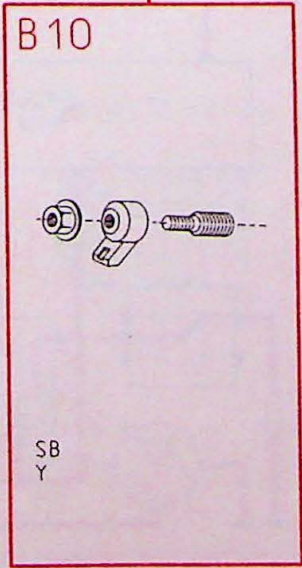
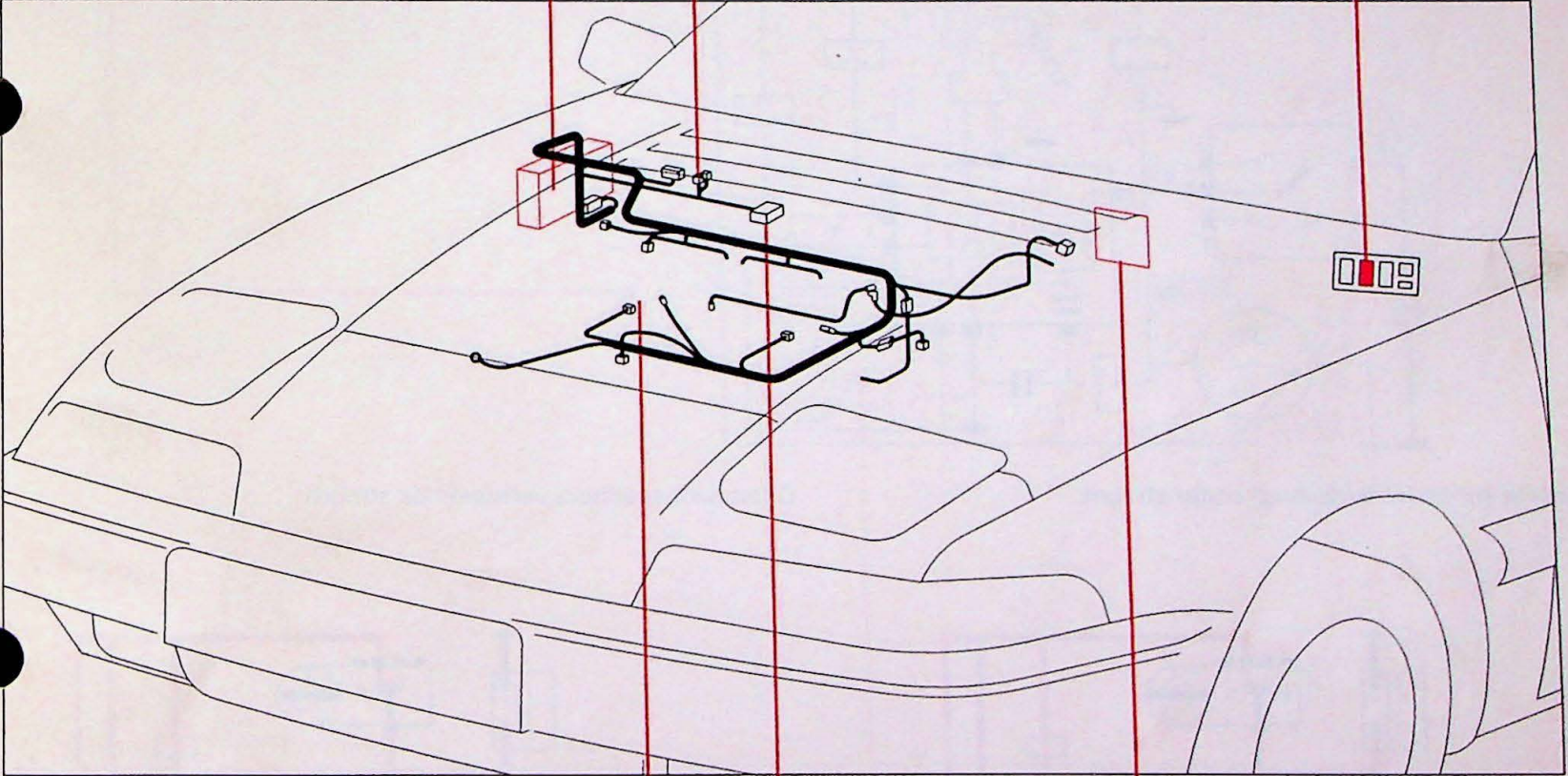
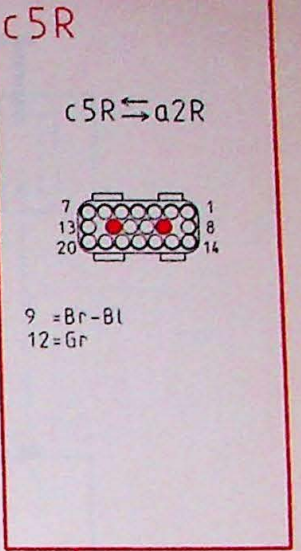
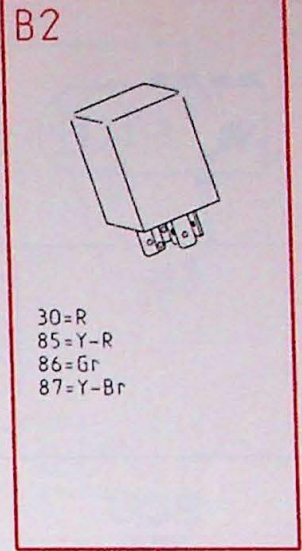
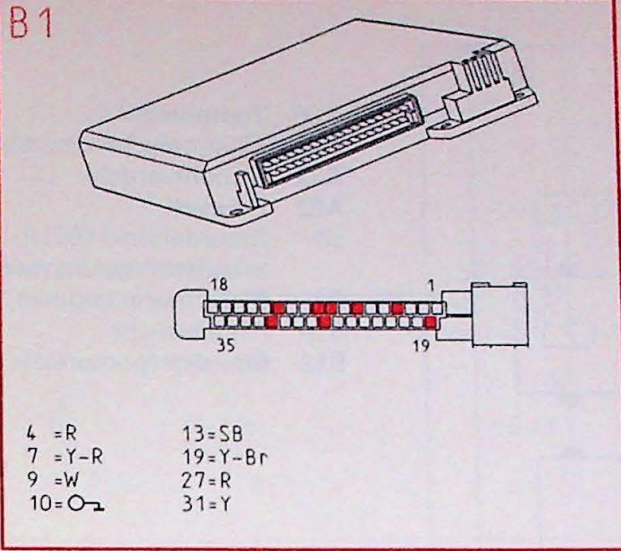

# Elektronische ontsteking, B18 F motoren

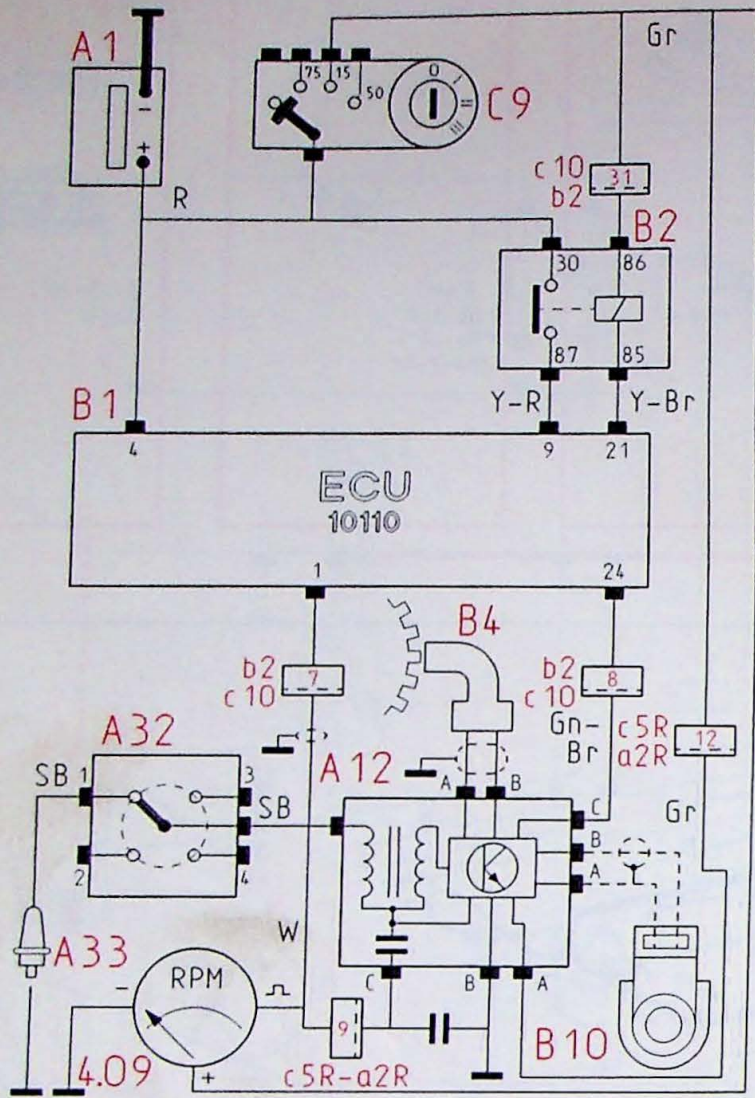

- 4.09 Toerenteller
- A12 Elektronische ontstekingseenheid
- A32 Stroomverdeler
- A33 Bougies
- B1 Stuureenheid (ECU)  
brandstofinspuitsysteem
- B4 Motortoerentalgever, vliegwiel
- B10 Pingelsensor
- B12 Brandstofpomprelais

Bobine (primaire wikkeling) onder stroom

Ontstekingseenheid verbreekt de stroom

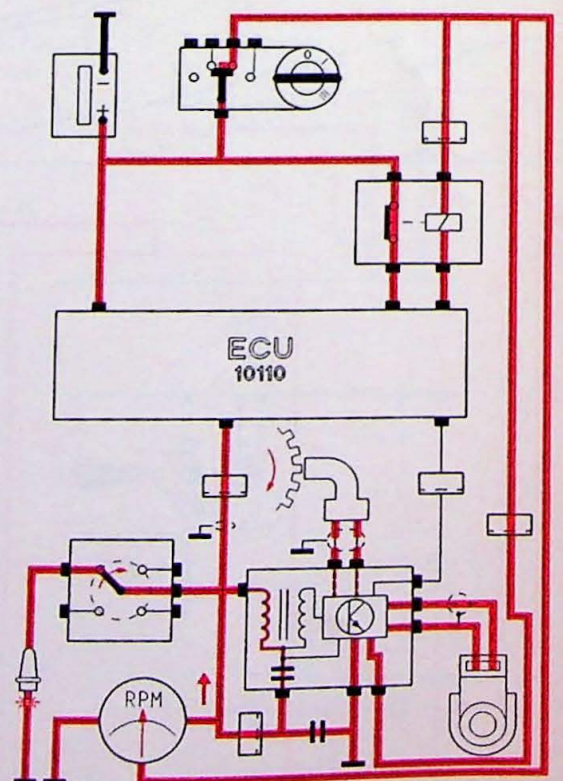
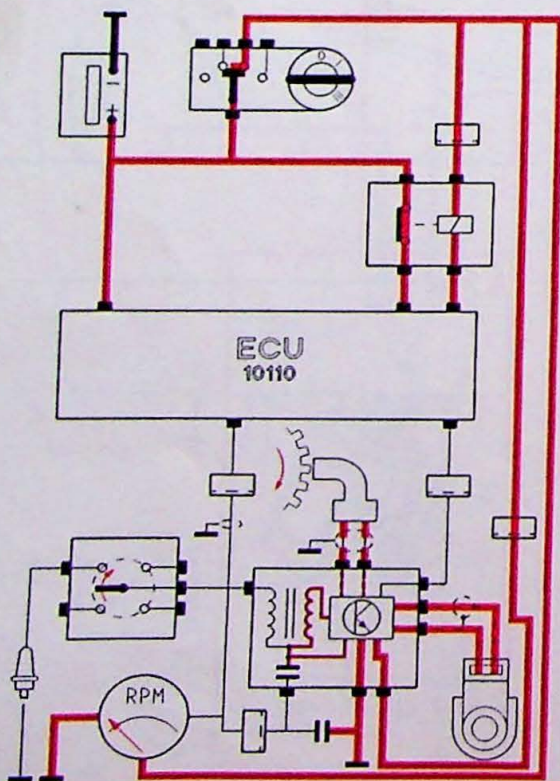

8-013/060

# Elektronische ontsteking, B18 F motoren

B10

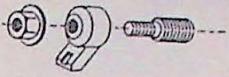

B1

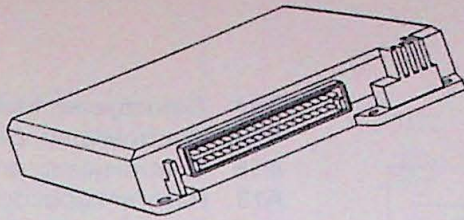

1 =W  
4 =R  
9 =Y-R  
21=Y-Br  
24=Gn-Br

B2

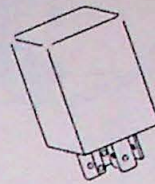

30=R  
85=Y-Br  
86=Gr  
87=Y-R

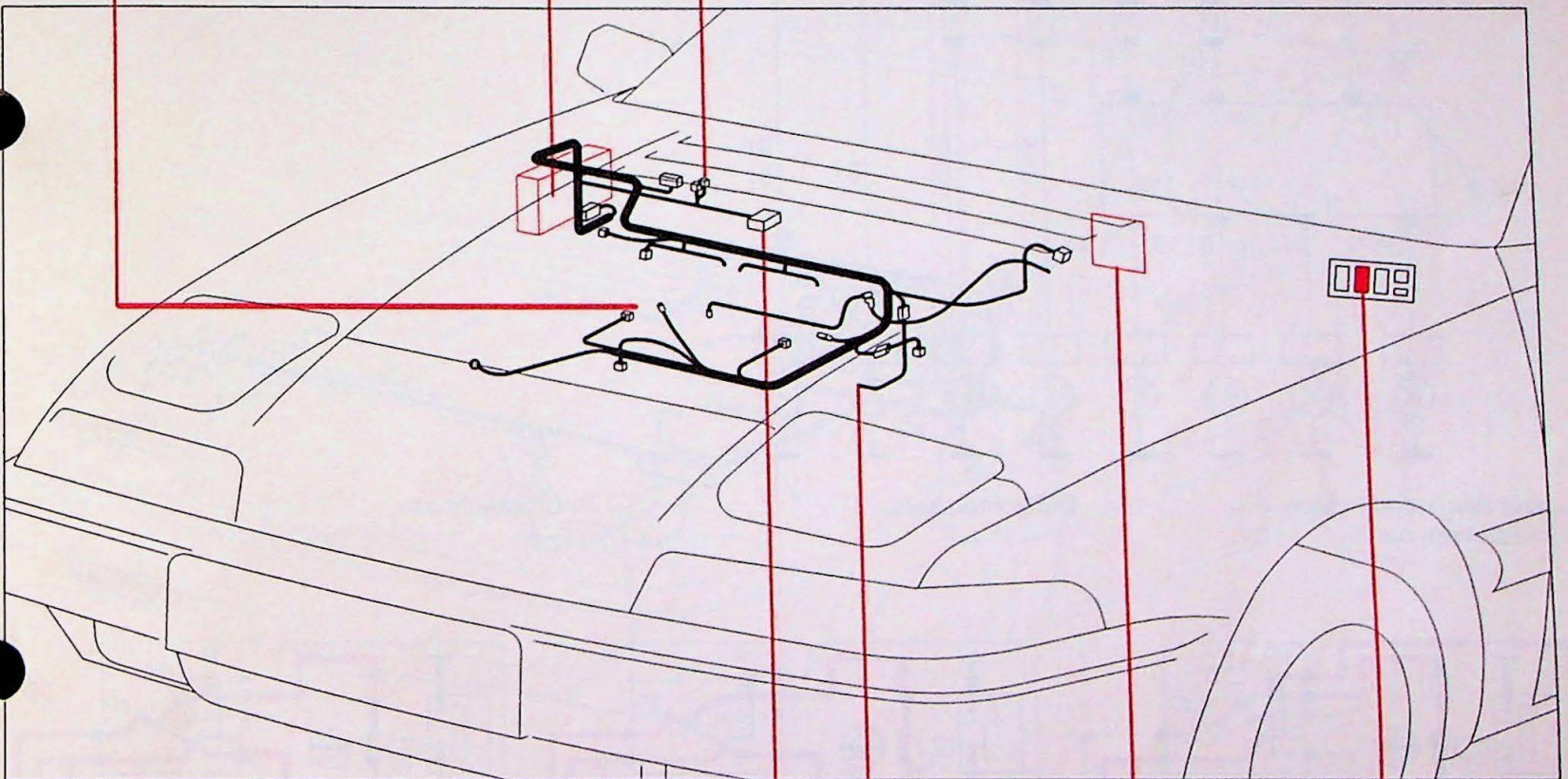

c 10 (c)

c 10 (a) ↔ b2 (a)

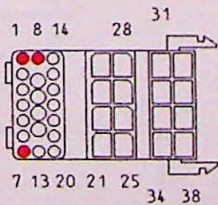

1 =Gr  
7 =W  
8 =Gn-Br

B4

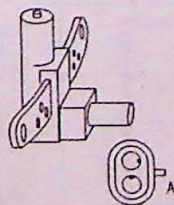

A12

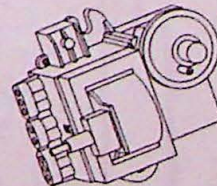

I  
a =B10  
b =B10  
c =Gn-Br  
III  
a =Gr  
b =Br  
c =W

II  
a =B4  
b =B4

c5R

c5R ↔ a2R

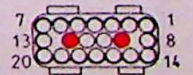

9 =W  
12=Gr

# Verlichting, voor (met dagrijlichten)

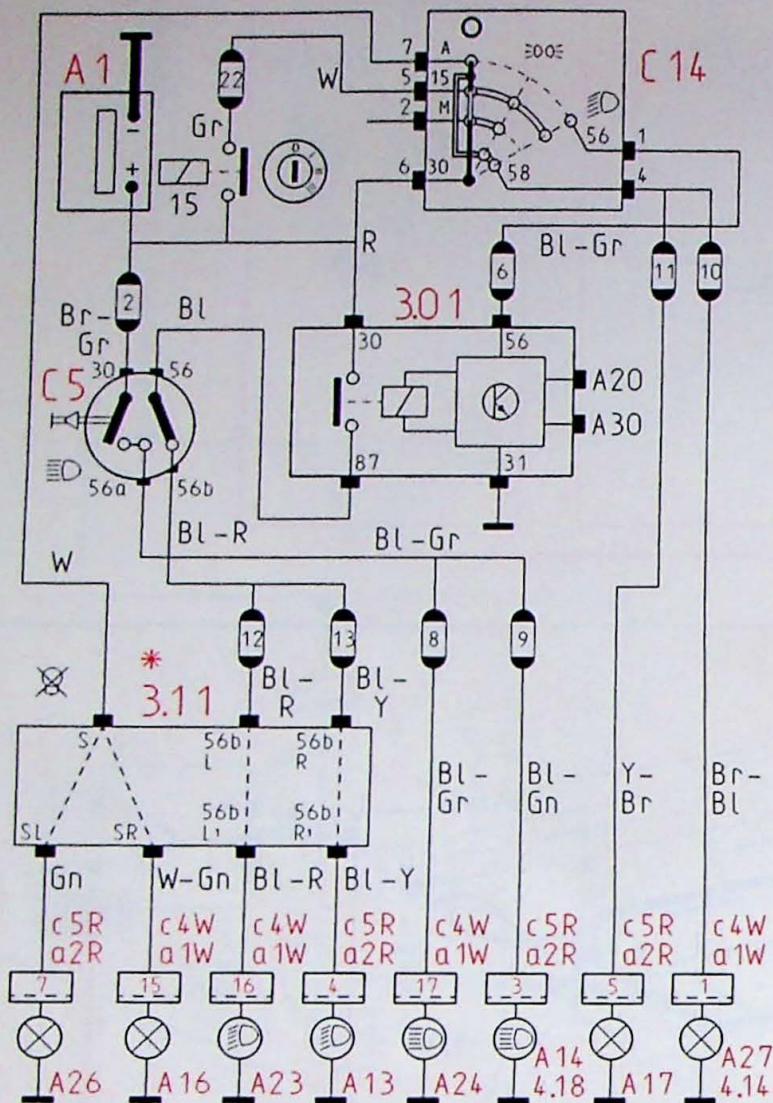

- 3.11 Defectgever, gloeilampen voor
- 4.14 Controlelamp, parkeerlicht
- 4.18 Controlelamp, grootlicht/lichtsignaal
- A13 Rechter koplamp, dimlicht
- A14 Rechter koplamp, grootlicht
- A17 Rechter parkeerlicht
- A23 Linker koplamp, dimlicht
- A24 Linker koplamp, grootlicht
- A27 Linker parkeerlicht
- C5 Grootlicht-/dimlichtschakelaar
- C14 Lichtschakelaar

\* Relais 3.11, vanaf chassisnr. 529392 alléén voor dagrijlichten

Contact aan, dagrijlichten + parkeerlichten aan.

Dimlichten aan.

Grootlicht aan.

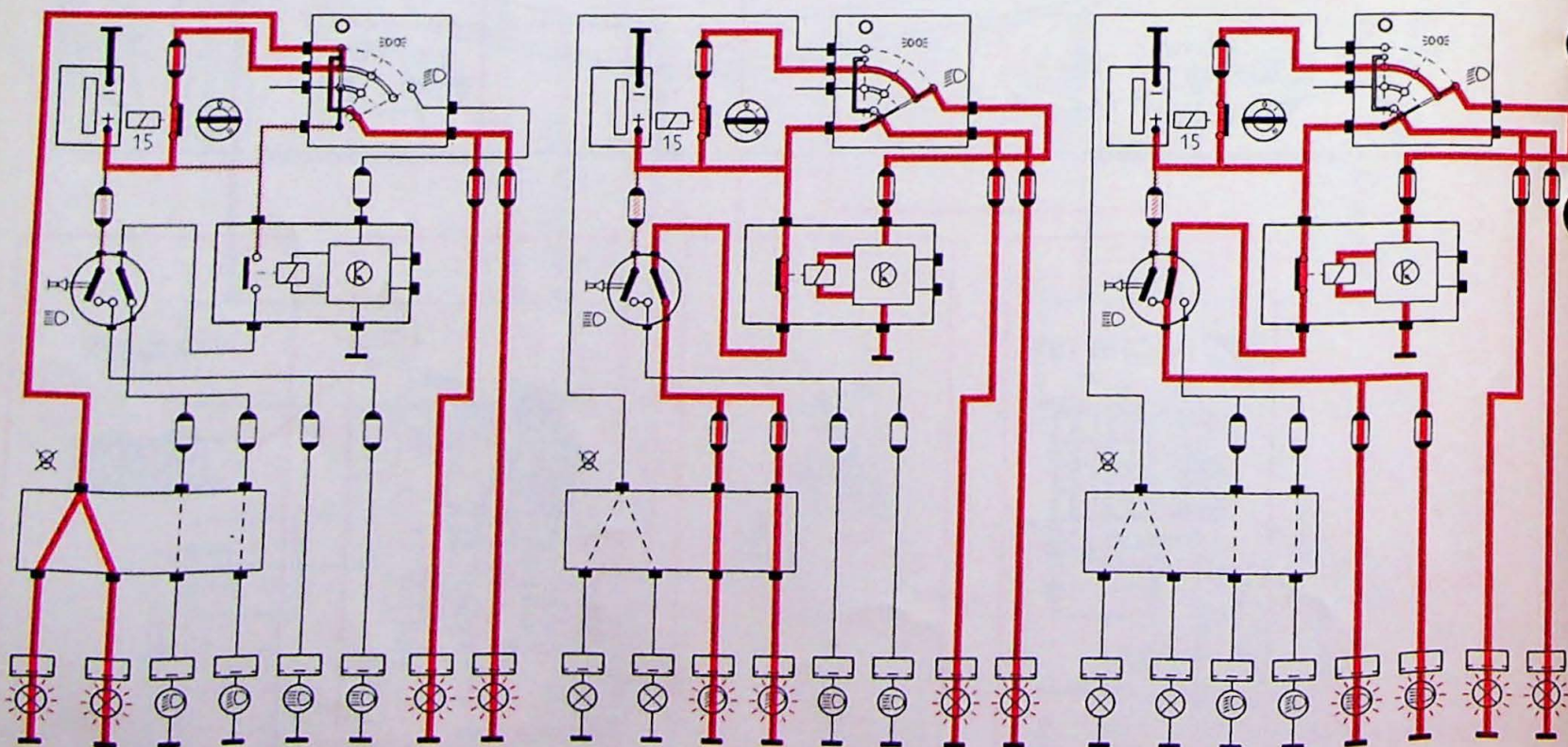

8-013/017

# Verlichting, voor (met dagrijlichten)

**c5R**

c5R ↔ a2R

3 = Bl-Gn	A14
4 = Bl-Y	A13
5 = Y-Br	A17
7 = Gn	A26

**c4W**

c4W ↔ a1W

1 = Br-Bl	A27
15 = W-Gn	A16
16 = Bl-R	A23
17 = Bl-Gr	A24

**c5**

30 = Br-Gr  
56 = Bl  
56a = Bl-Gr  
56b = Bl-R

**C14**

58 M  
30  
15  
A 56

A = W  
15 = W  
30 = R  
56 = Bl  
58 = SB

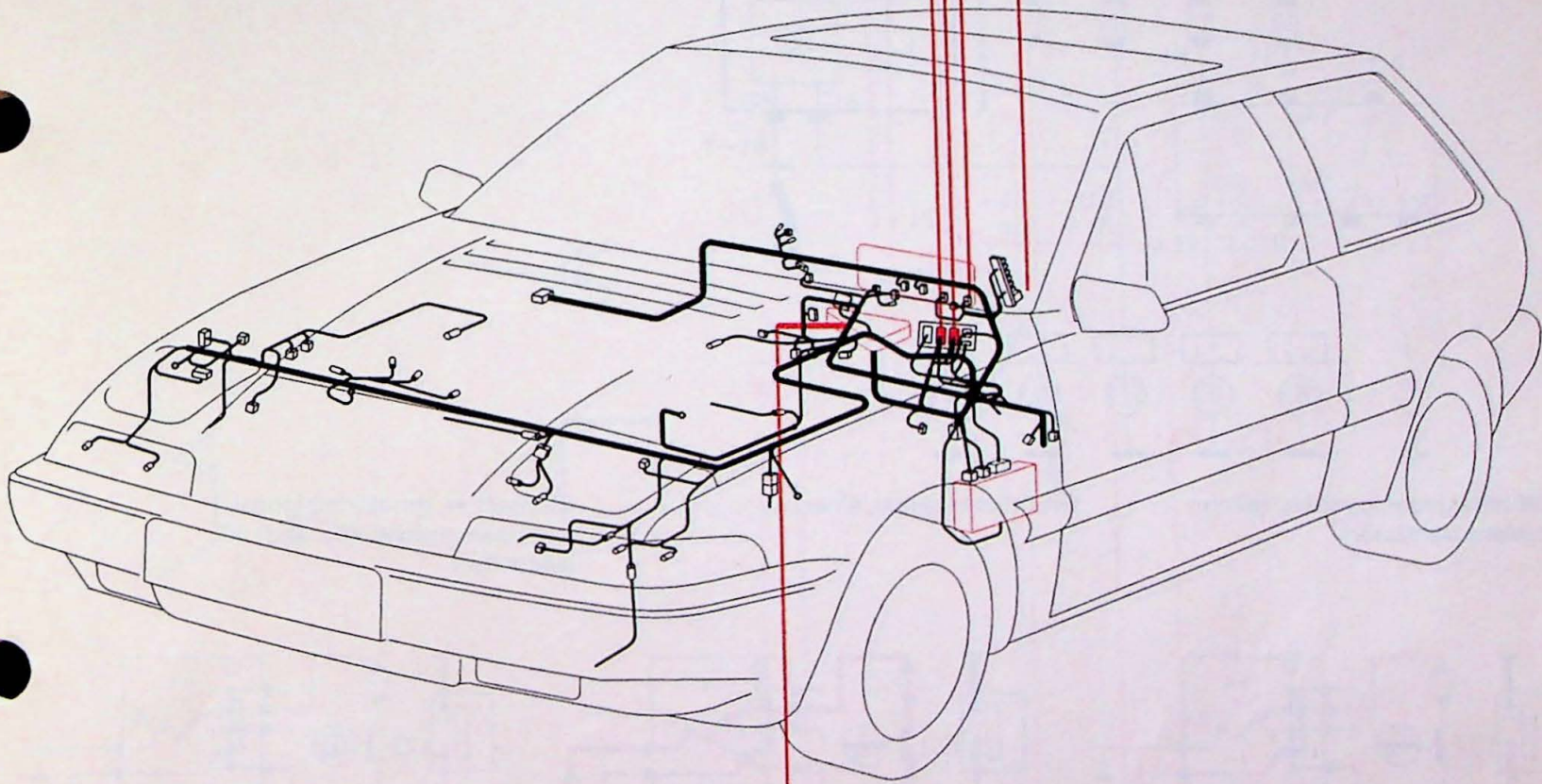

**3.0**

**3.01**

A = 1988

**3.13**

A = 1989

**3.11**

L = 1988 - ○  
L = 1989 - □

# Grootlichtsignaal, verstralers, oprijlaanverlichting

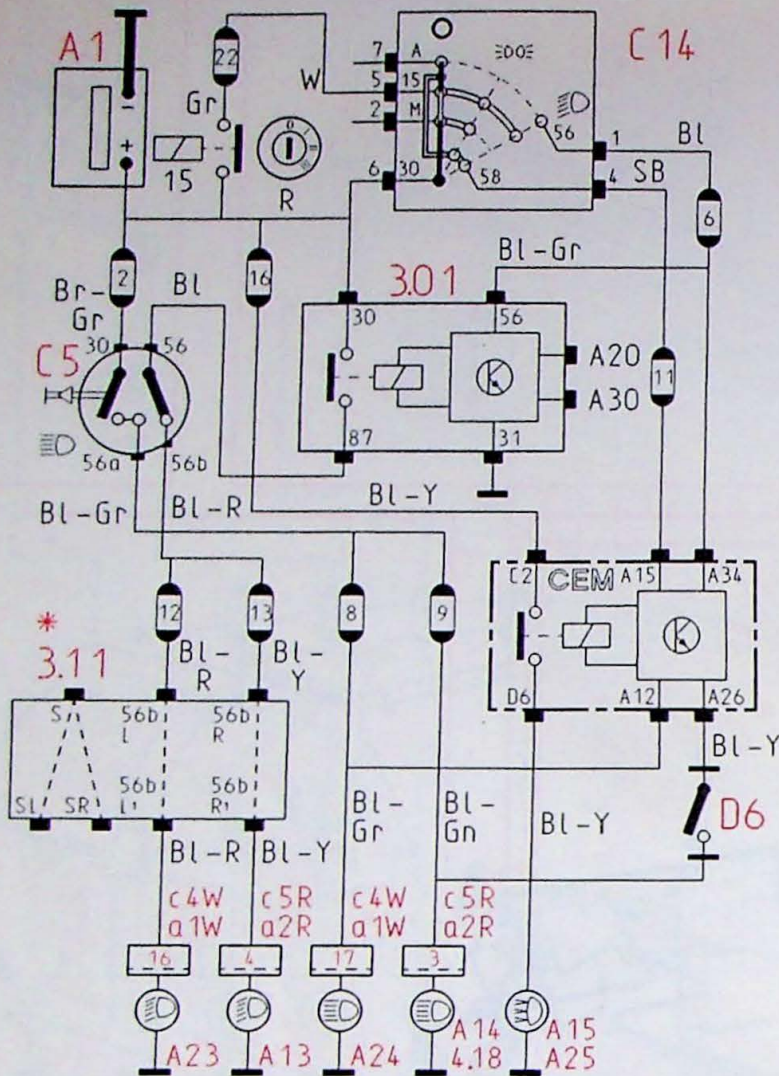

- 3.01 Koplampvoeding-sperrelais
- 3.11 Defectgever, gloeilampen voor
- A13 Rechter koplamp, dimlicht
- A14 Rechter koplamp, grootlicht
- A15 Rechter verstraler
- A23 Linker koplamp, dimlicht
- A24 Linker koplamp, grootlicht
- A25 Linker verstraler
- C5 Grootlicht-/dimlichtschakelaar
- C14 Lichtschakelaar
- D6 Schakelaar verstralers

\* Relais 3.11 vanaf chassisnummer 529392 alléén voor dagrijlichten.

Grootlichtsignaal, overdag (alleen verstralers zichtbaar)

Grootlichtsignaal, s' nachts

Contact af, grootlichtsignaal, oprijlaanverlichting brandt 30 seconden

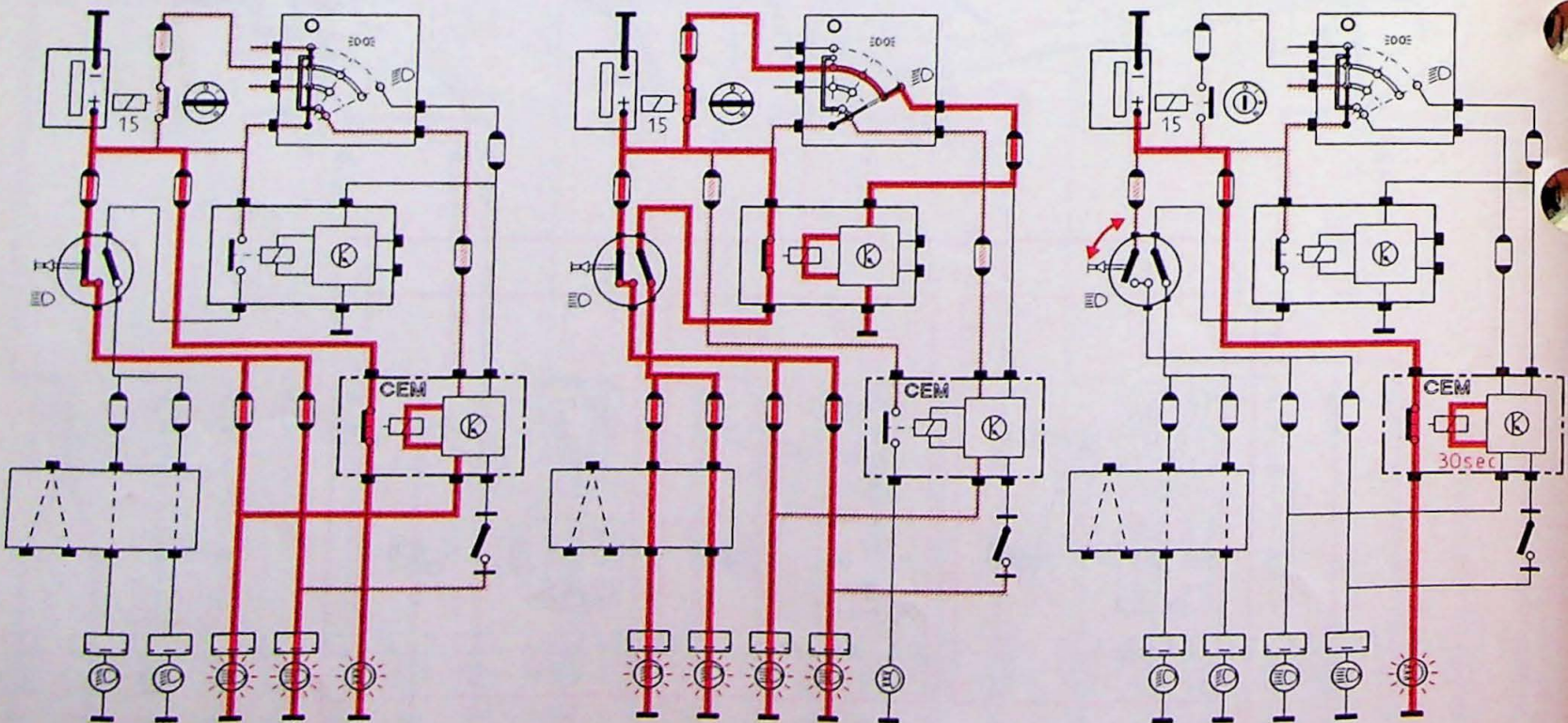

8-013/017B

# Grootlichtsignaal, verstralers, oprijlaanverlichting

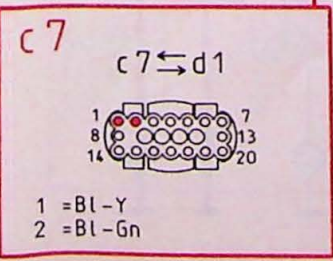
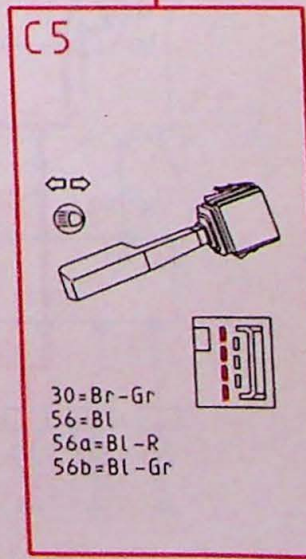
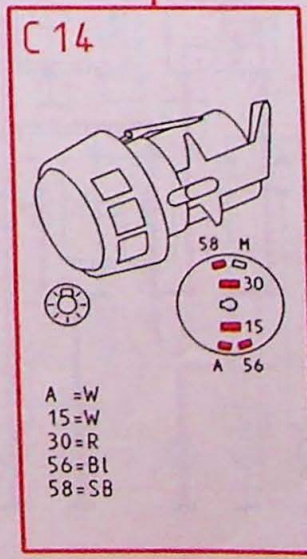
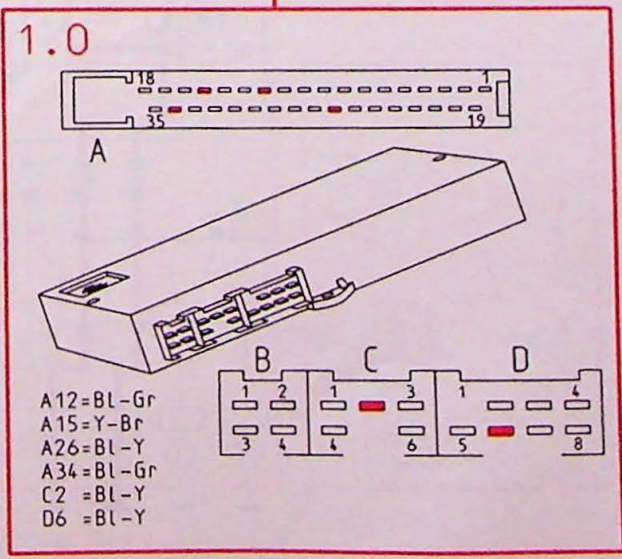
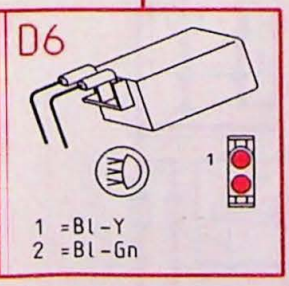
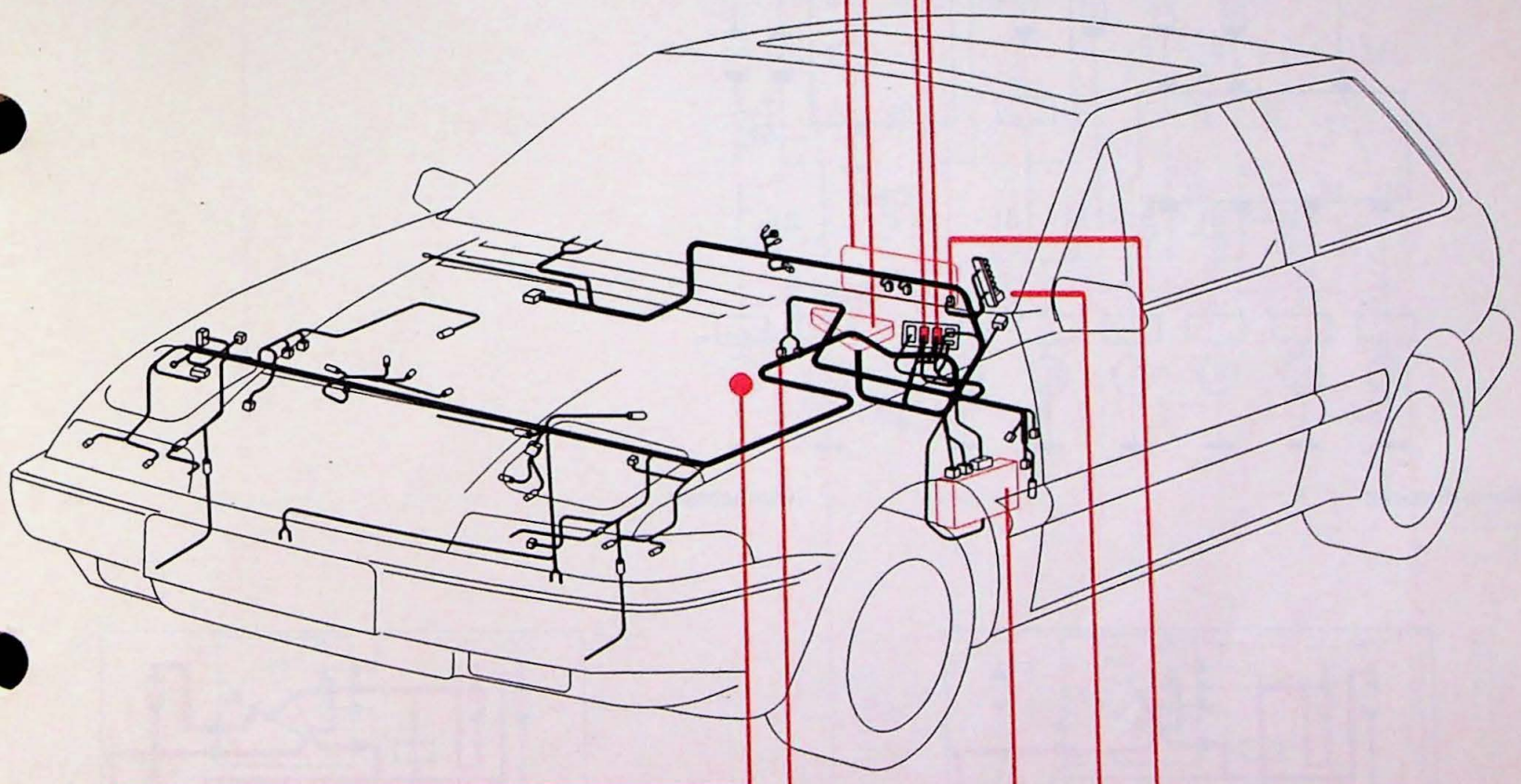
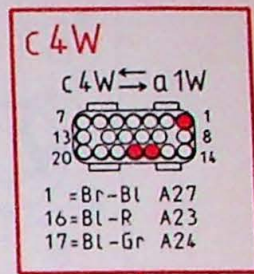
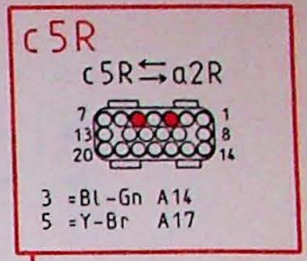
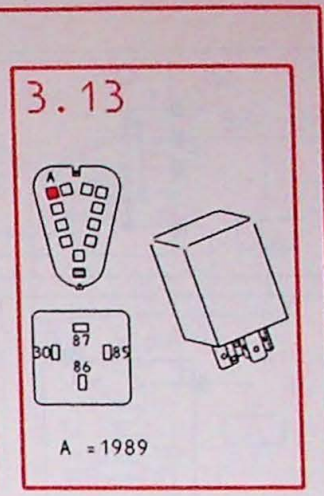
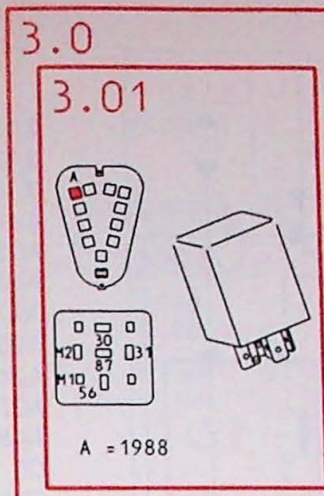
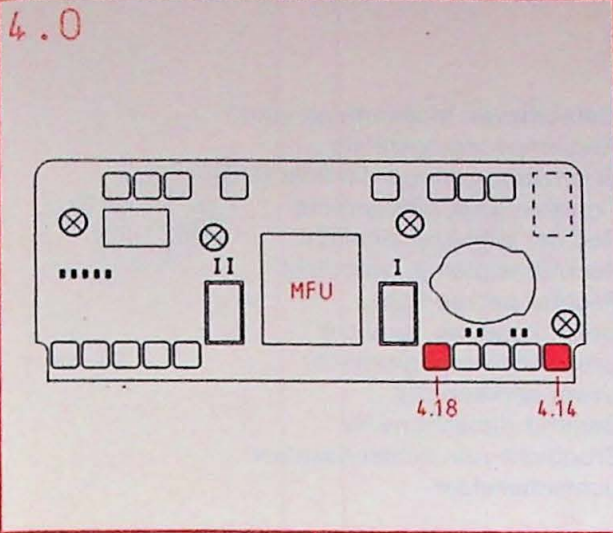

# Gedimd-dimlicht, dimlicht GB

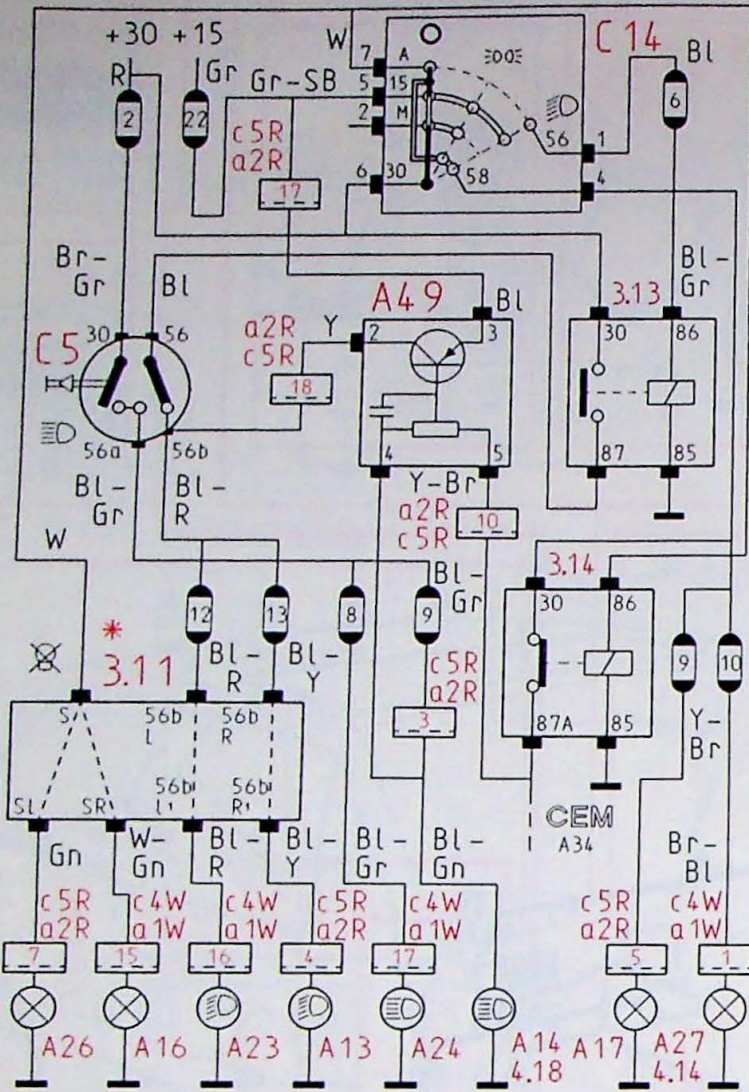

- 3.11 Defectgever, gloeilampen voor
- 3.13 Koplampvoedingsrelais
- 3.14 Sperrelais, gedimd-dimlicht (GB)
- 4.14 Controlelamp, parkeerlicht
- A13 Rechter koplamp, dimlicht
- A14 Rechter koplamp, grootlicht
- A17 Rechter parkeerlicht
- A23 Linker koplamp, dimlicht
- A24 Linker koplamp, grootlicht
- A27 Linker parkeerlicht
- A49 Gedimd-dimlicht relais
- C5 Grootlicht-/dimlichtschakelaar
- C14 Lichtschakelaar

\* Relais 3.11 vanaf chassisnummer 529392  
alleén voor dagrijlichten

Gedimd-dimlicht

Dimlichten

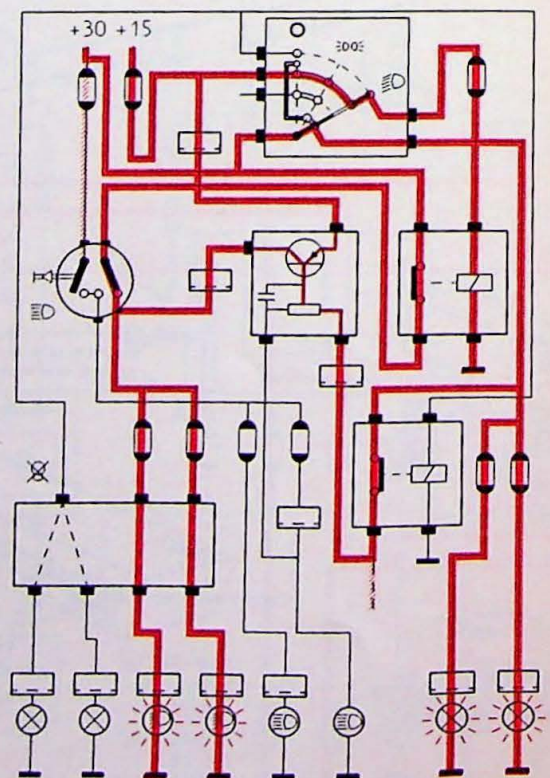
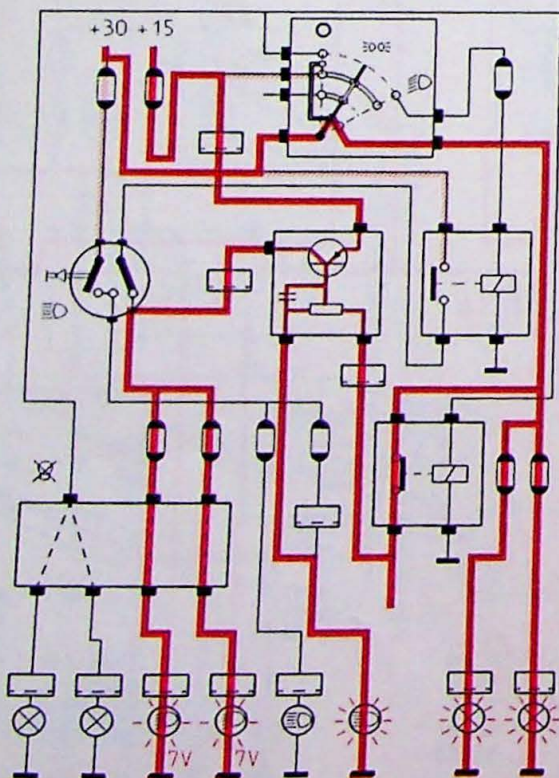

8-013/025

# Gedimd-dimlicht, dimlicht GB

A49

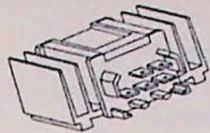

- 2 = Y
- 3 = Bl
- 4 = Bl-Gn
- 5 = Y-Br

c5R

c5R ↔ a2R

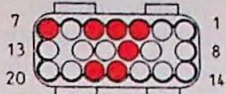

- 3 = Bl-Gn A14
- 4 = Bl-Y A13
- 5 = Y-Br A17
- 7 = Gn A26
- 10 = Y-Br
- 17 = Gr-SB (Bl)
- 18 = Y

c4W

c4W ↔ a1W

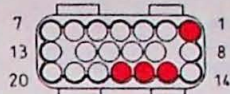

- 1 = Br-Bl A27
- 15 = W-Gn A16
- 16 = Bl-R A23
- 17 = Bl-Gr A24

C5

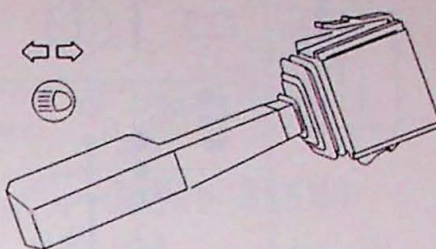

- 30 = Br-Gr
- 56 = Bl
- 56a = Bl-Gr
- 56b = Bl-R

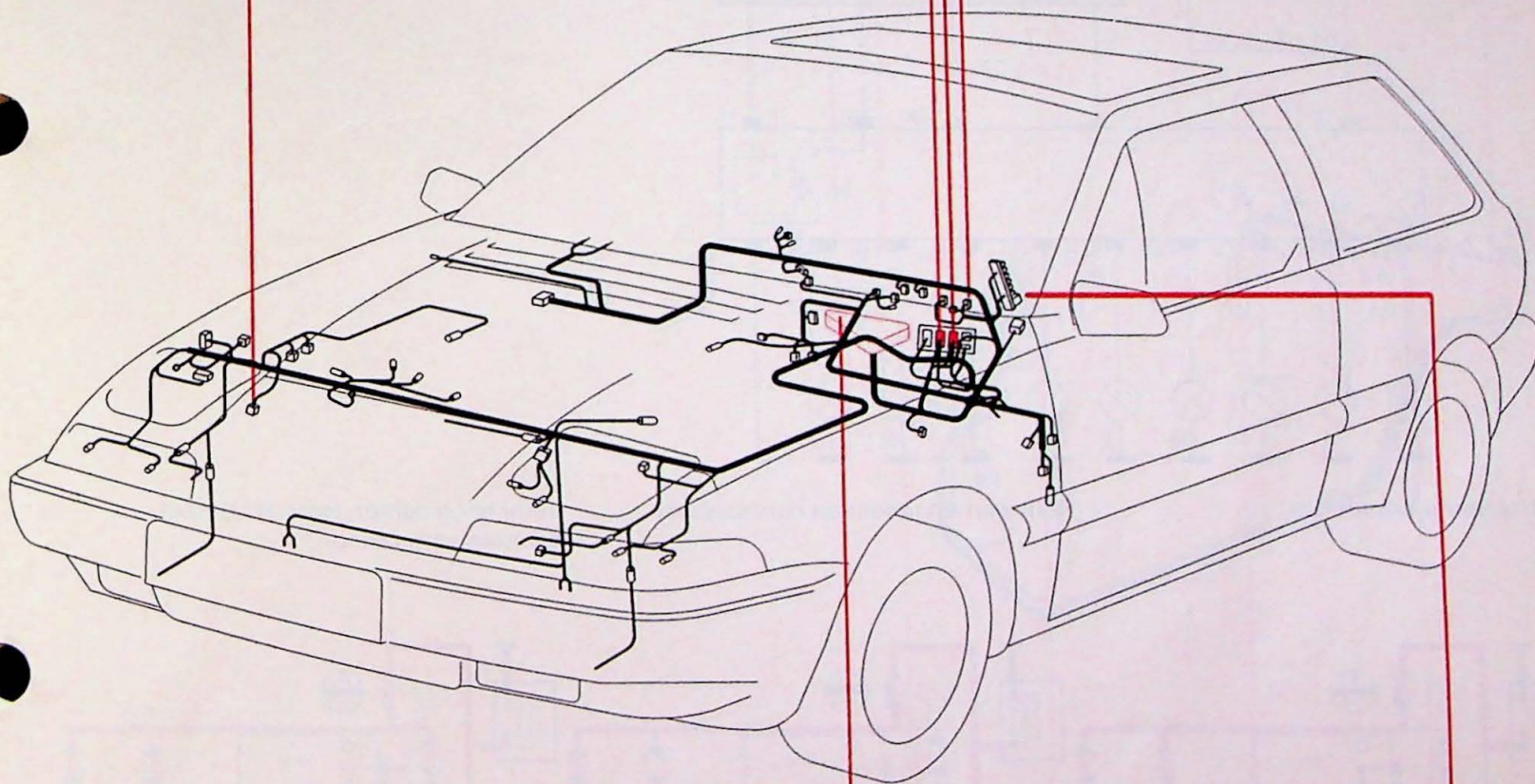

3.0

3.13

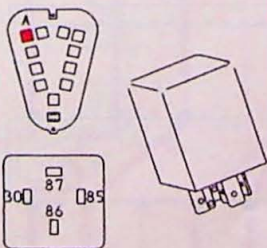

3.14

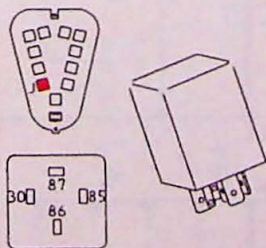

3.11

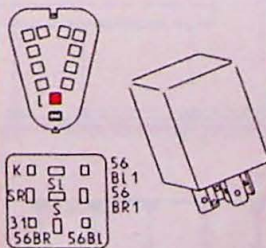

- L = 1988 - ○
- L = 1989 - □

3.11

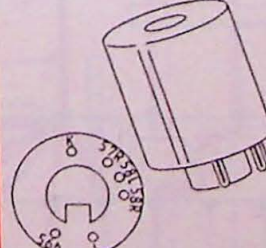

C14

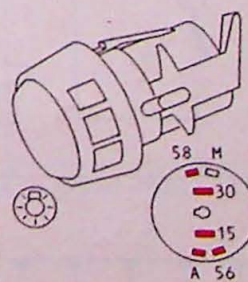

- A = W
- 15 = W
- 30 = R
- 56 = Bl
- 58 = SB

# Verlichting achter met lamp-defectcontrole

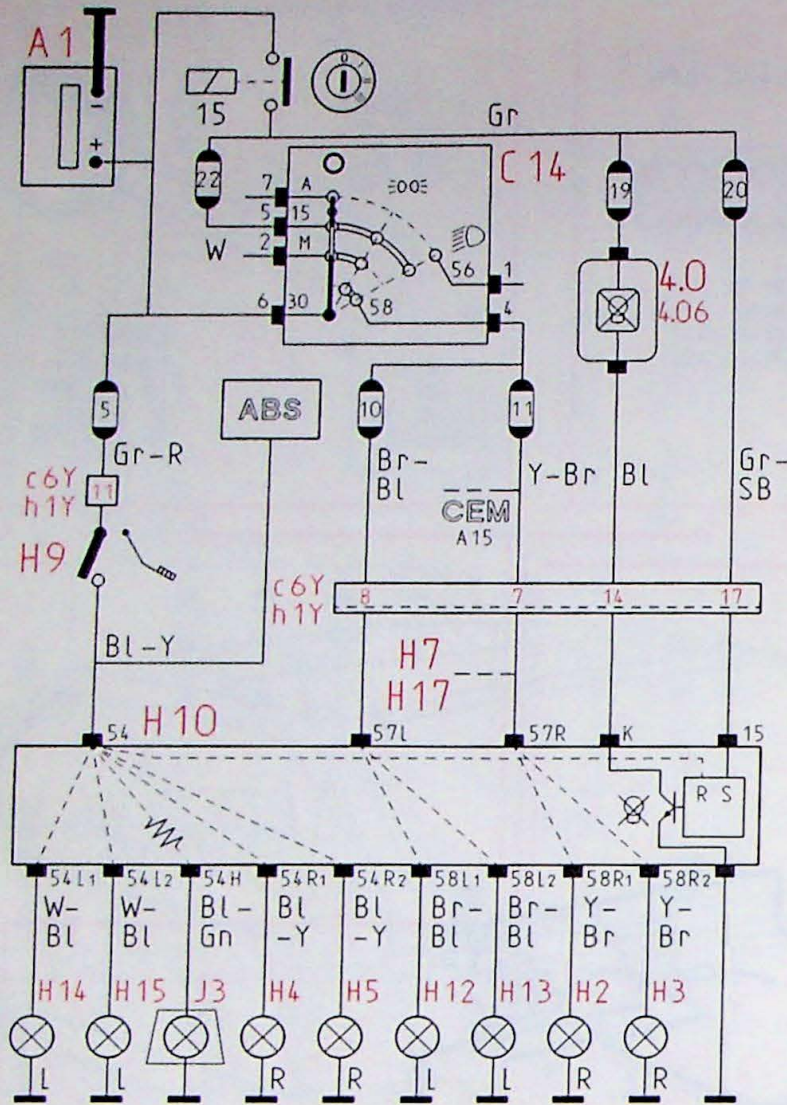

- 4.06 Controlelamp, defecte gloeilamp(en)
- H9 Schakelaar remlichten
- C14 Lichtschakelaar
- H2,H3 Lampdraad achterlicht, rechts
- H4 Lampdraad remlicht, rechts
- H10 Defectgever, gloeilampen achter
- H12,H13 Lampdraad achterlicht, links
- H14 Remlicht, links
- J3 Remlicht midden

Controlelamp brandt

Remmen en reset van controlelamp

Verlichting achter, lamp H2 defect, controlelamp brandt

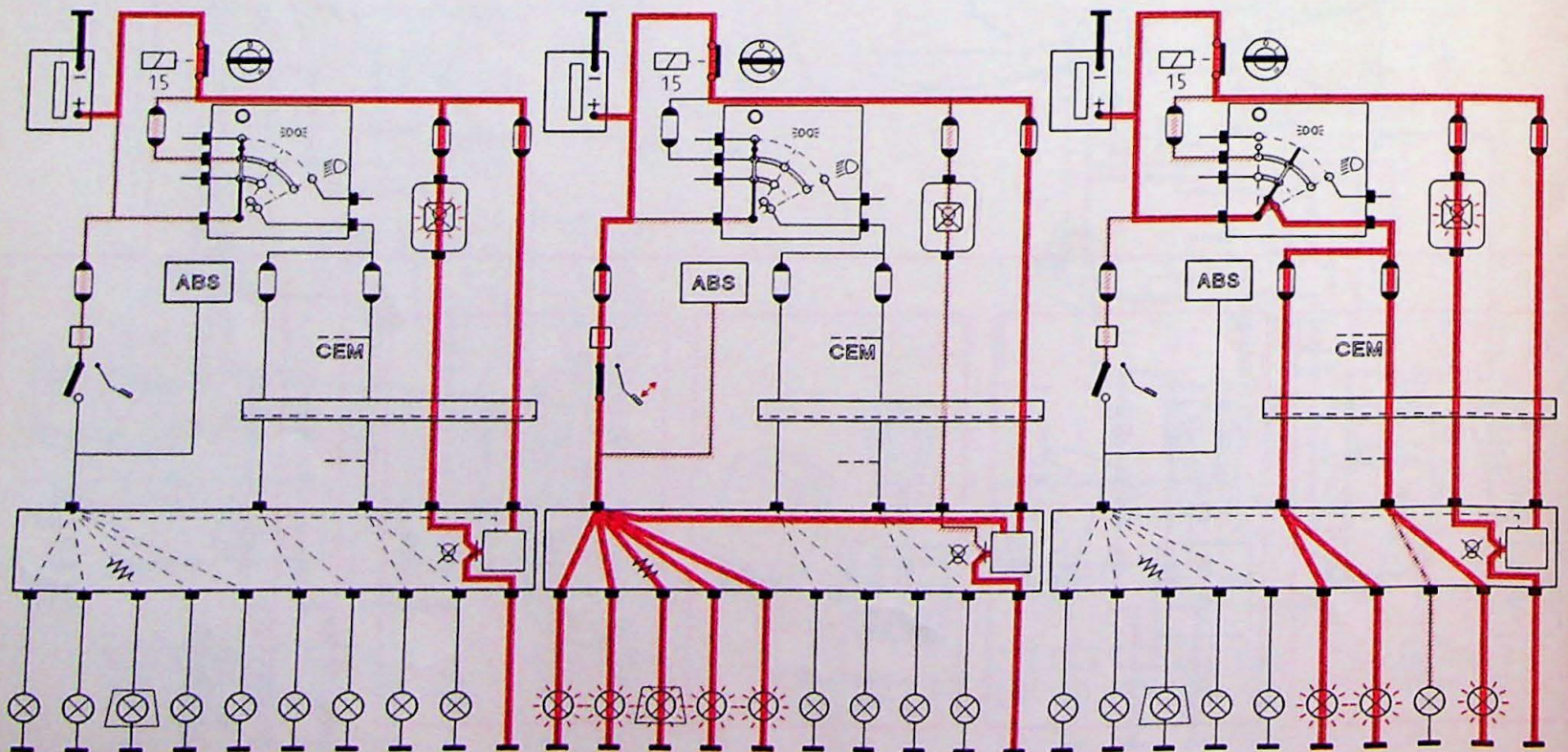

8-013/042

# Verlichting achter met lamp-defectcontrole

c6Y

c6Y ↔ h1Y

7 = Y-Br  
8 = Br-Bl  
11 = Gr-R  
14 = Bl  
17 = Gr-SB

4.0

4.06

MFU

H10

<A>		<B>	
1 = Br-Bl	58L2	1 = Bl-Y	54R2
2 = Y-Br	58R1	2 = W-Bl	54L1
3 = Y-Br	58R2	3 = W-Bl	54L2
4 = Y-Br	57R	4 = Bl-Gn	54H
5 = Br-Bl	58L1	5 = Bl-Y	54
6 = Br-Bl	57L	6 = Gr-SB	15
8 = Bl-Y	54R1	8 = Bl	K

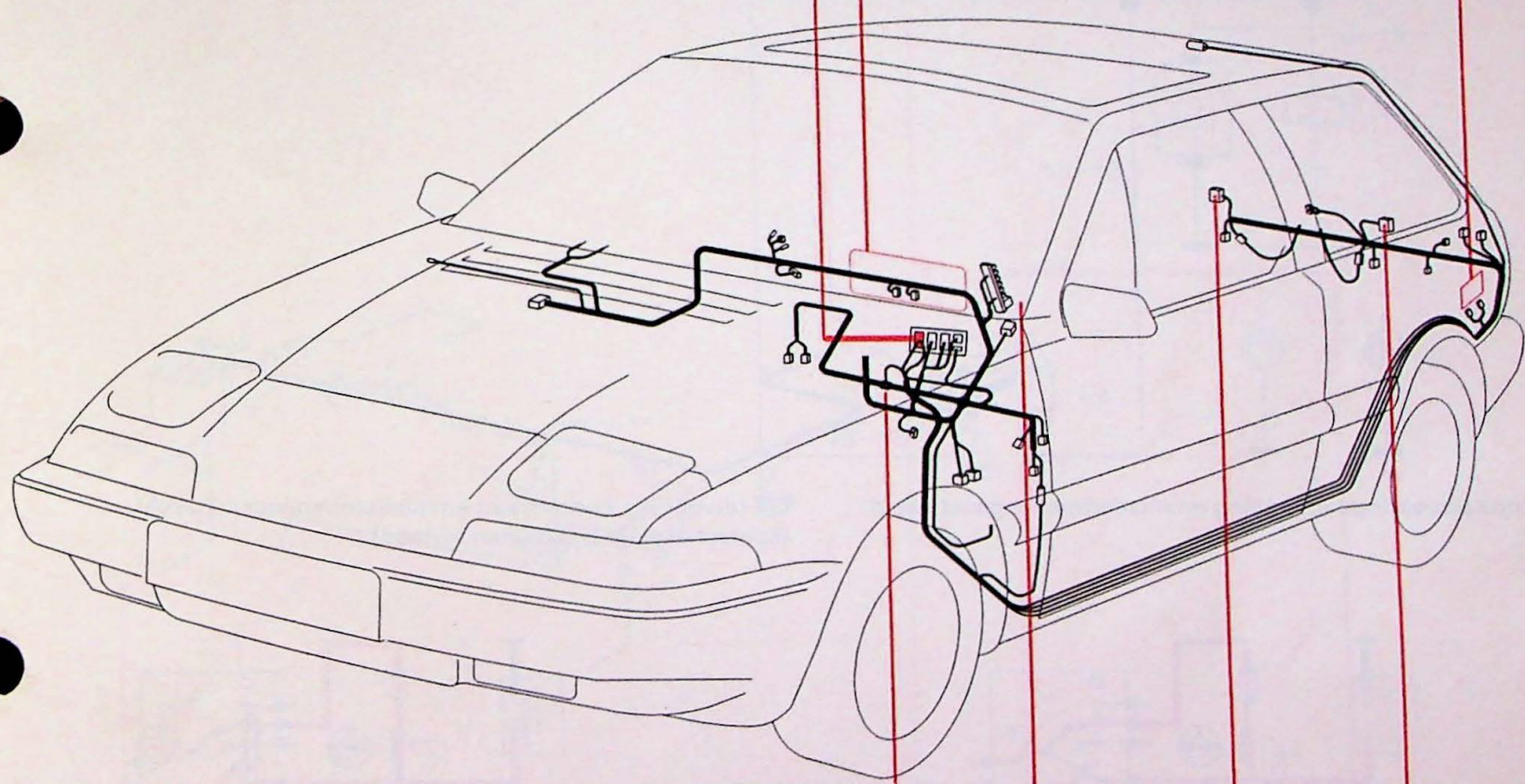

H9

Gr-R  
Bl-Y

C14

58 M  
30  
15  
A 56

15=W  
30=R  
56=Bl  
58=SB

H2-H3-H4-H5

4 = Bl-Y  
5 = Y-Br  
6 = Y-Br  
7 = Bl-Y

H12-H13-H14-H15

4 = W-Bl  
5 = Bl-Y  
6 = Bl-Y  
7 = W-Bl

# Mistlampen, Euro en GB

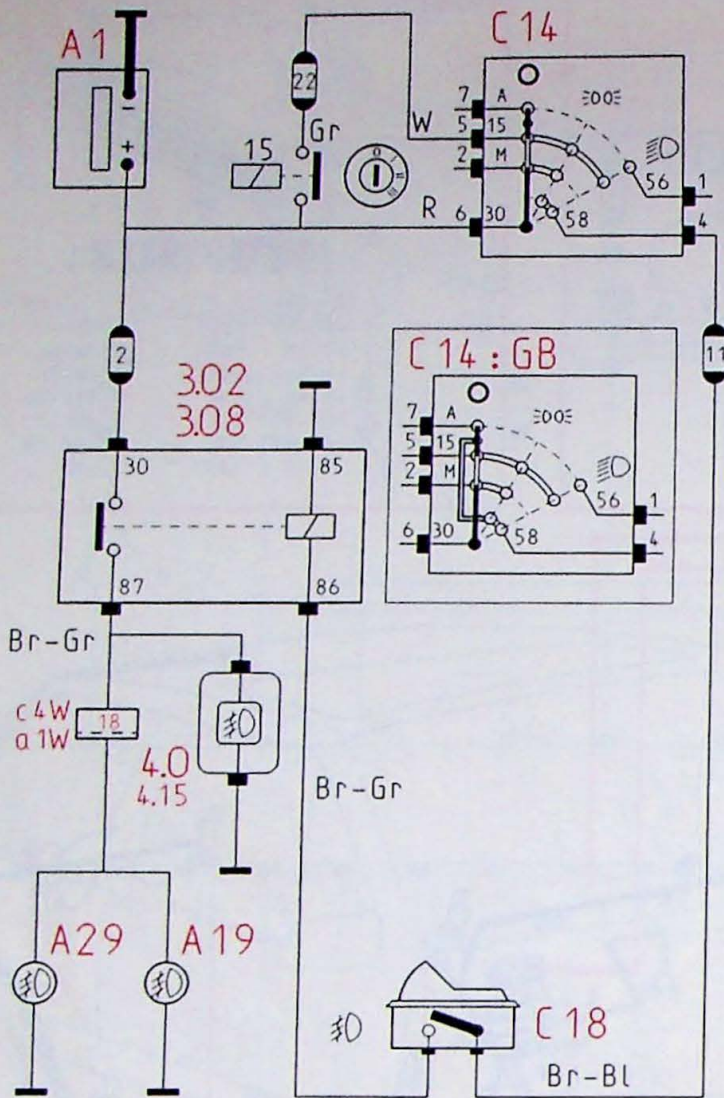

- 3.02 Relais, mistlampen tot 1988
- 3.08 Relais, mistlampen vanaf 1988
- 4.15 Controlelamp, mistlampen
- A19 Rechter mistlamp
- A29 Linker mistlamp
- C14 Lichtschakelaar
- C18 Mistlampschakelaar

Europa uitvoering: verlichting en mistlampen ingeschakeld

GB uitvoering: contact aan en mistlampen ingeschakeld (lichtschakelaar heeft geen invloed)

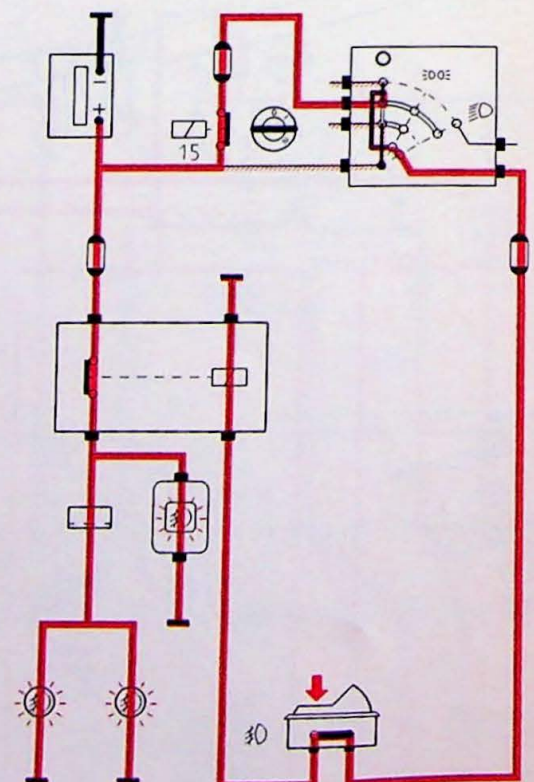
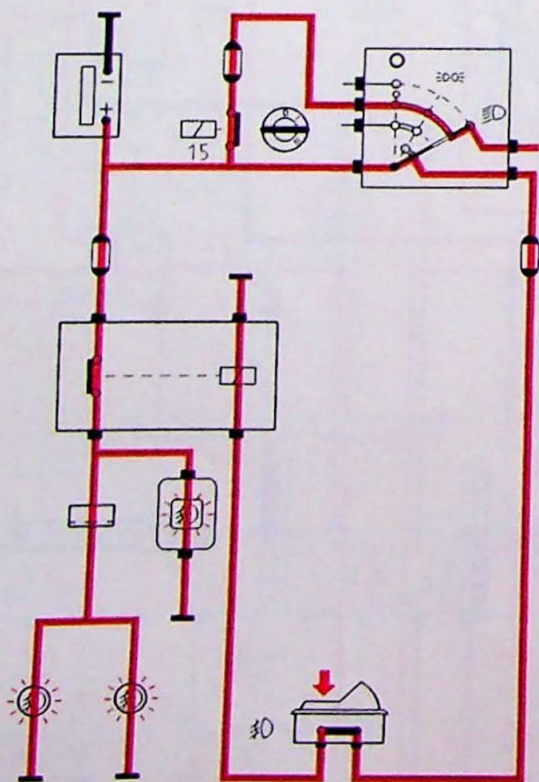

8-013/024

# Mistlampen, Europa en GB

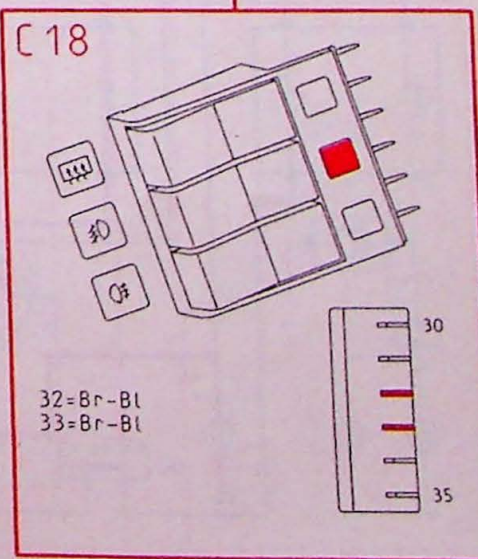
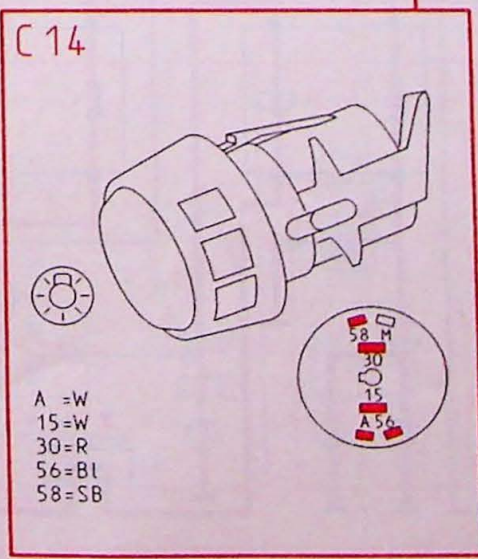
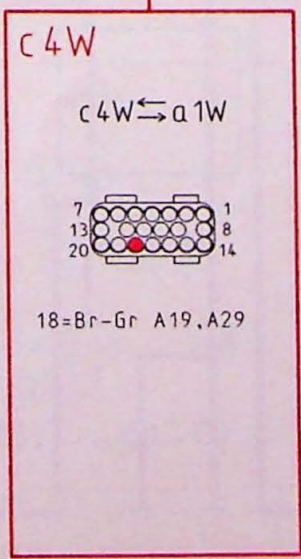
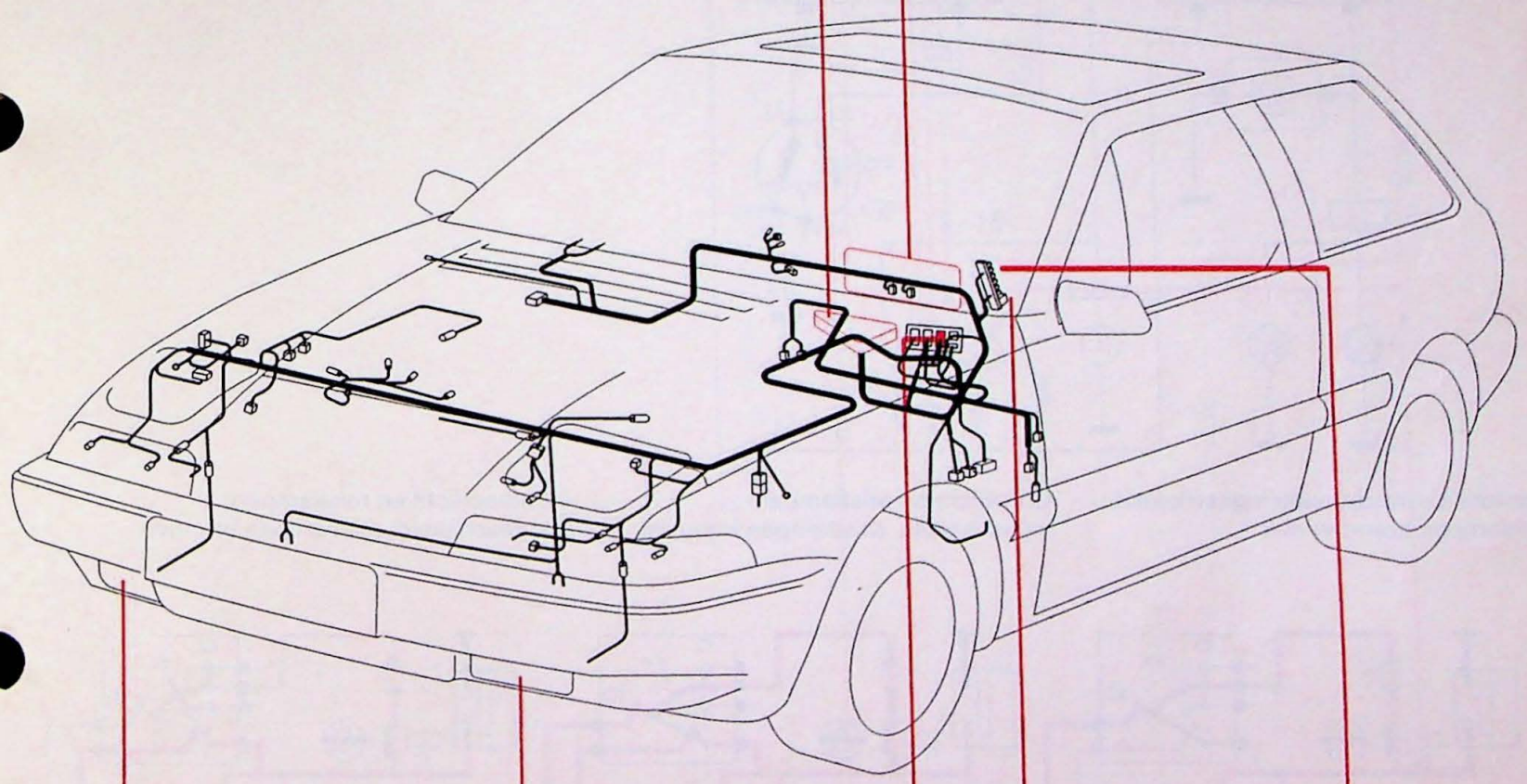
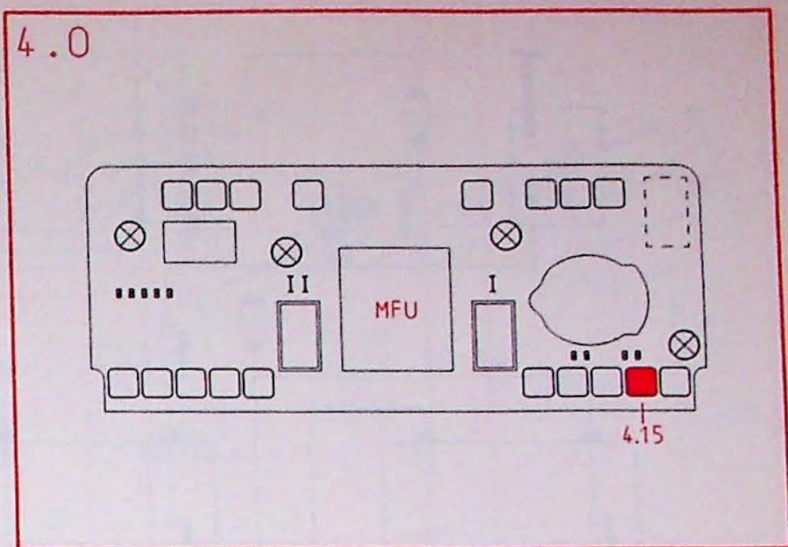
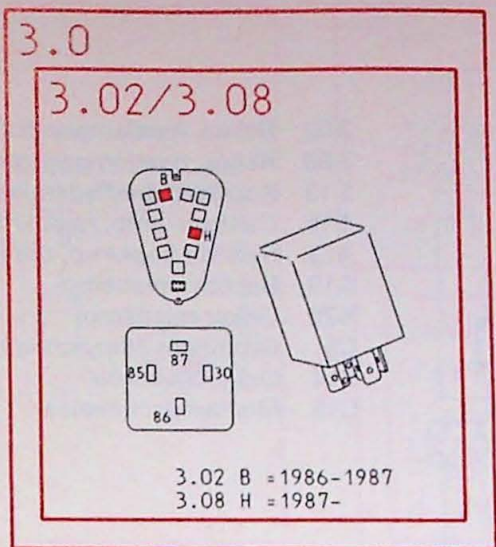

# Mistlampen, S en CH

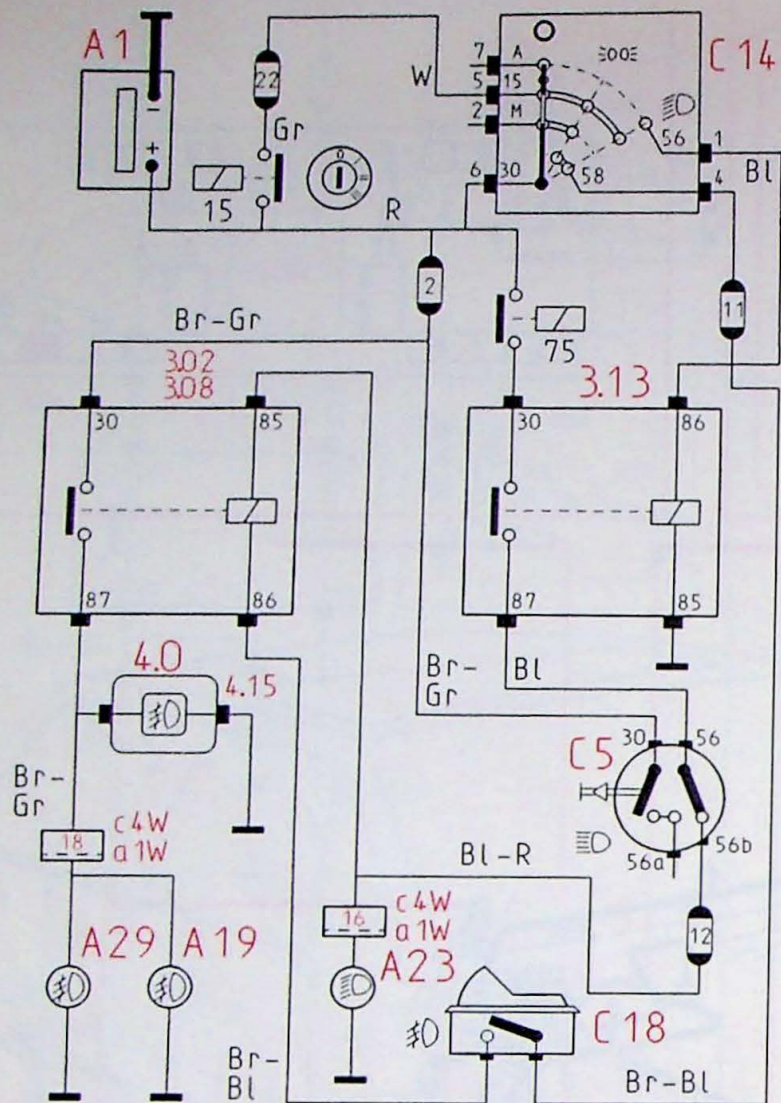

- 3.02 Relais, mistlampen tot 1988
- 3.08 Relais, mistlampen vanaf 1988
- 3.13 Koplampvoedingsrelais
- 4.15 Controlelamp, mistlampen
- A13 Rechter koplamp, dimlicht
- A19 Rechter mistlamp
- A29 Linker mistlamp
- C5 Grootlicht-/dimlichtschakelaar
- C14 Lichtschakelaar
- C18 Mistlampschakelaar

Dimlicht en mistlampen ingeschakeld, mistlampen branden niet

Grootlicht en mistlampen ingeschakeld, mistlampen branden

Parkeerlicht en mistlampen ingeschakeld, mistlampen branden

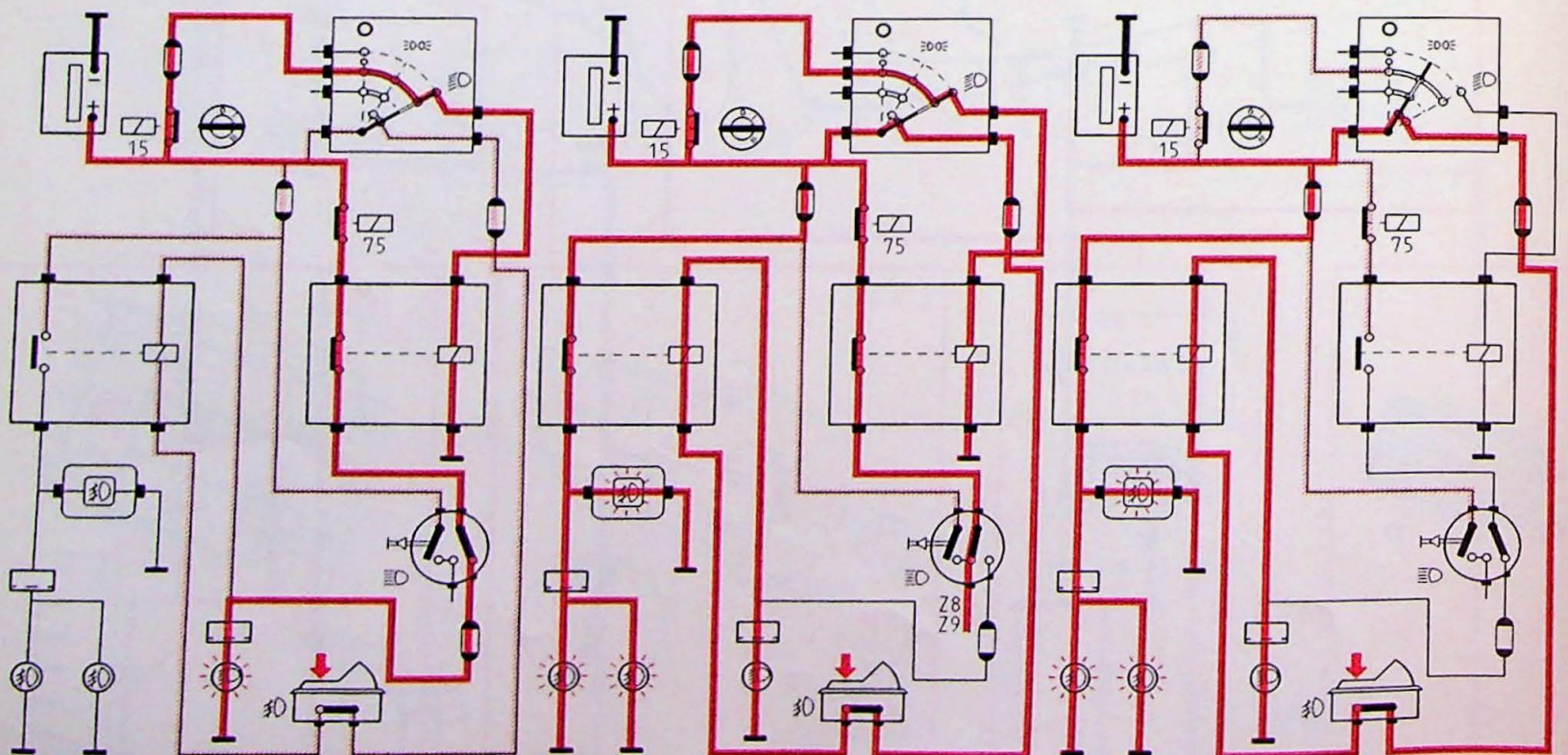

8-013/023

# Mistlampen, S en CH

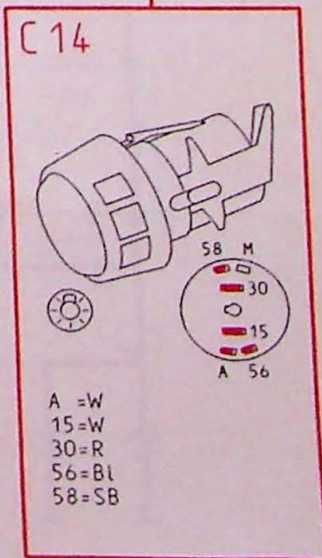
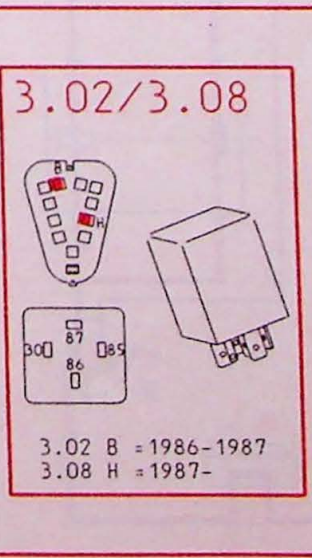
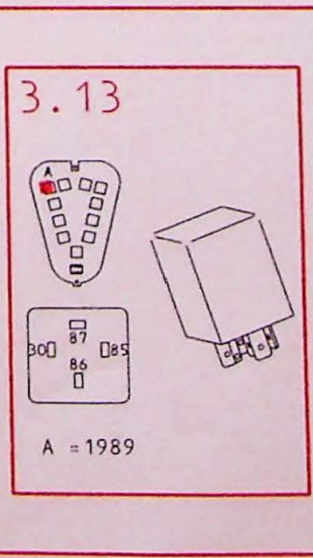
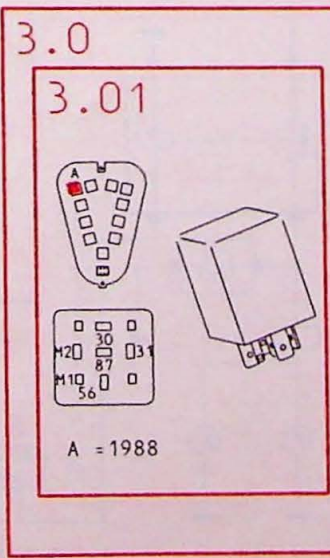
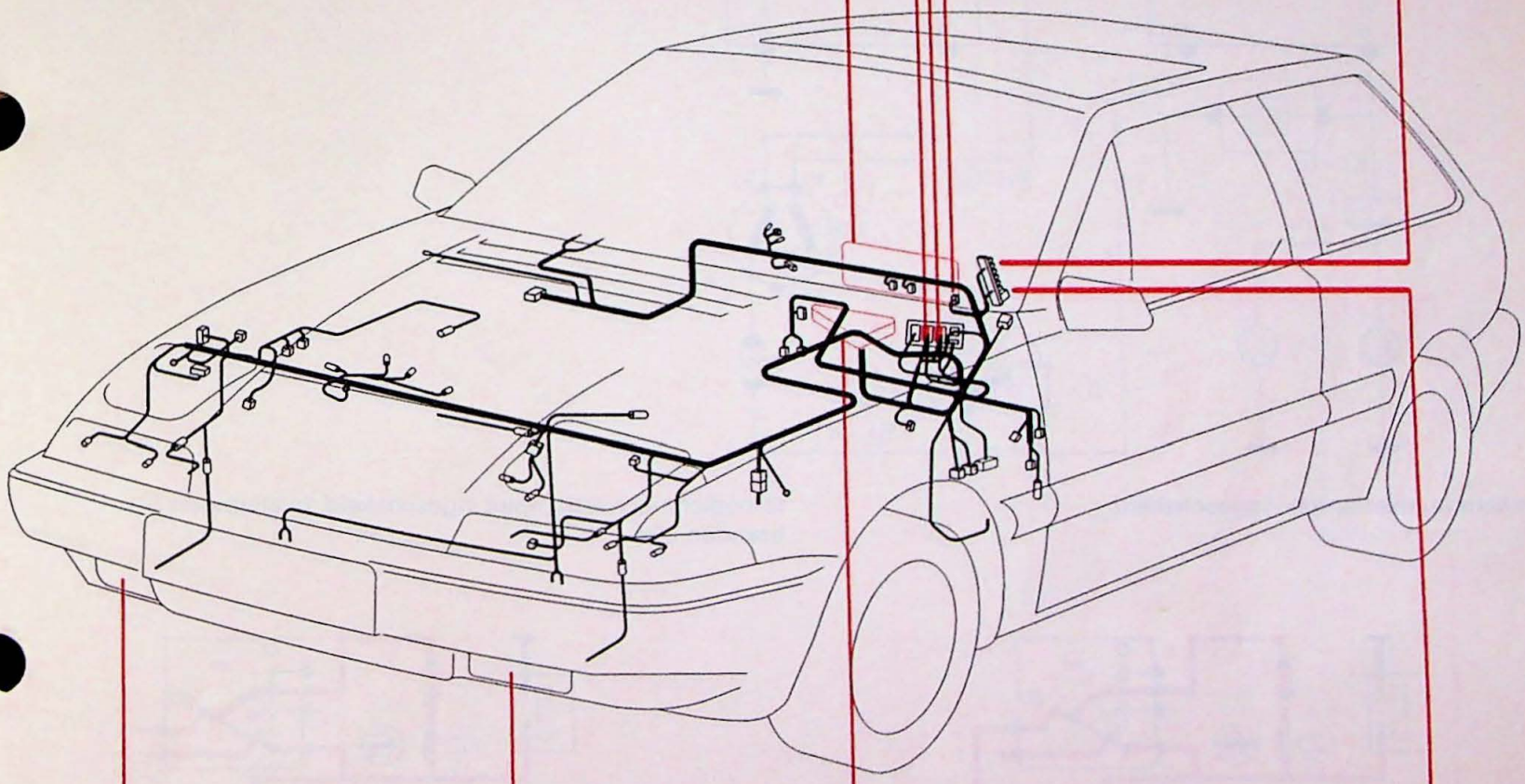
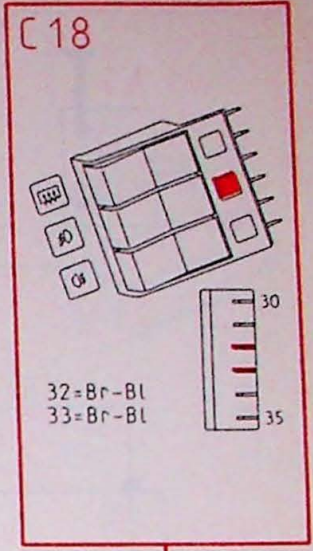
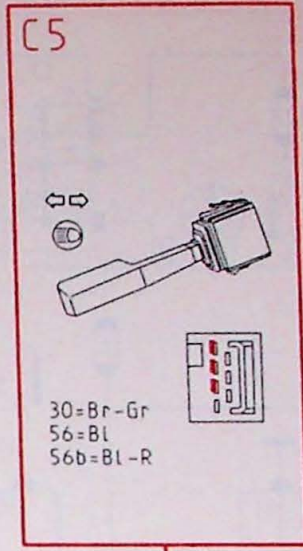
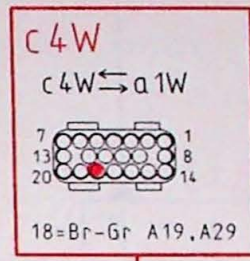
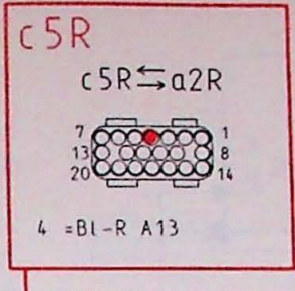
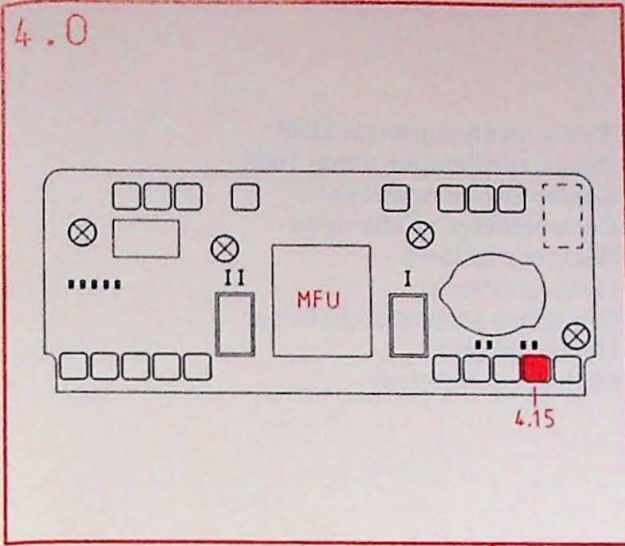

# Mistlampen, D en A

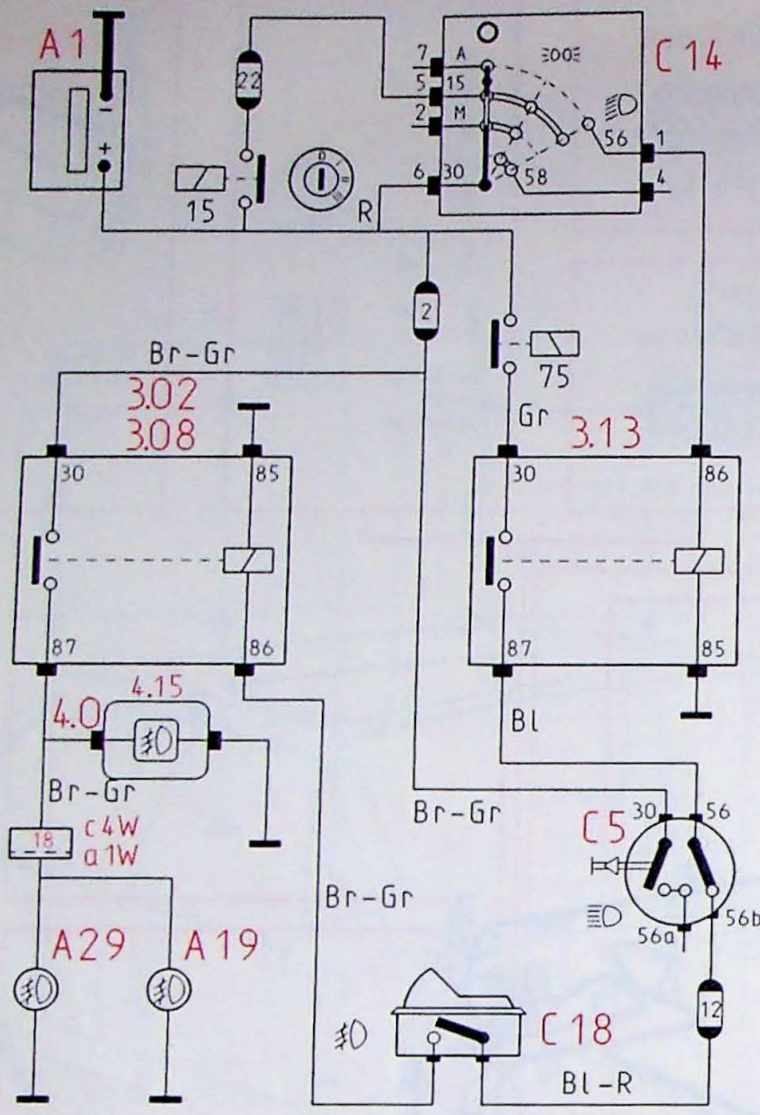

- 3.02 Relais, mistlampen tot 1988
- 3.08 Relais, mistlampen vanaf 1988
- 3.13 Koplampvoedingsrelais
- 4.15 Controlelamp, mistlampen
- A19 Rechter mistlamp
- A29 Linker mistlamp
- C5 Grootlicht-/dimlichtschakelaar
- C14 Lichtschakelaar
- C18 Mistlampschakelaar

Dimlicht en mistlampen ingeschakeld

Grootlicht en mistlampen ingeschakeld, mistlampen branden niet

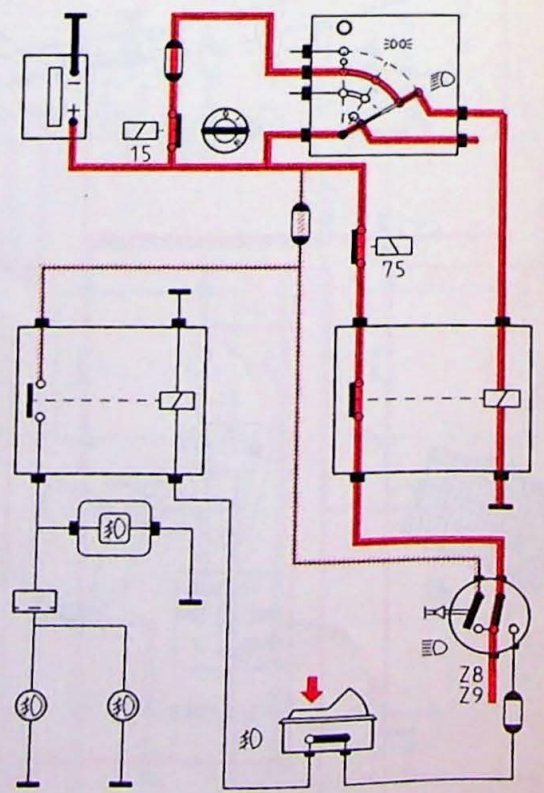
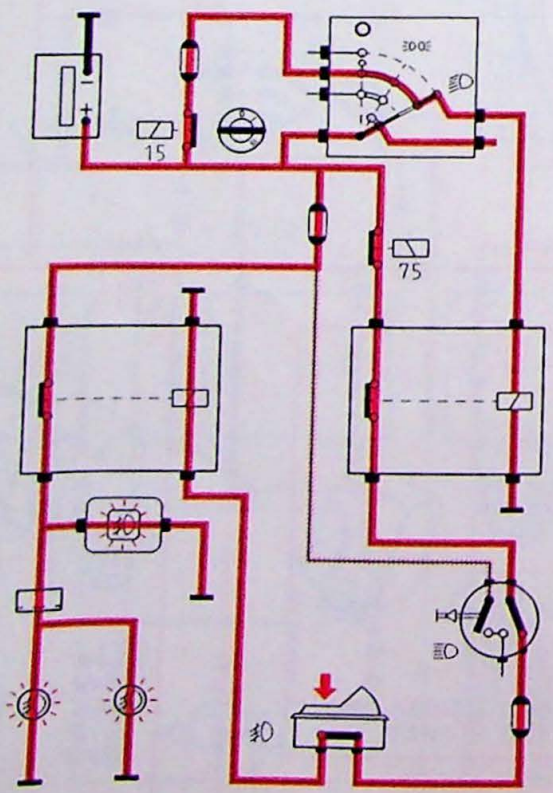

8-013/022

# Mistlampen, D en A

4.0

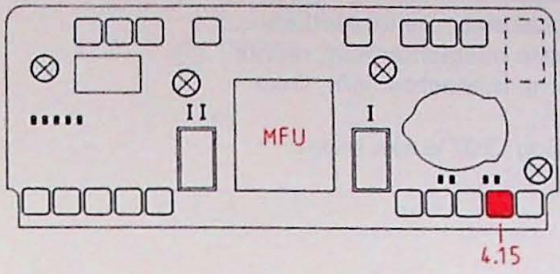

c4W

c4W ↔ a1W

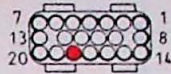

18=Br-Gr A19.A29

C5

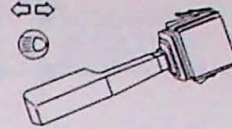

30=Br-Gr  
56=Bl  
56b=Bl-R

C18

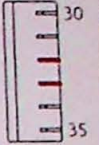
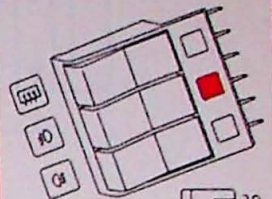

32=Br-Bl  
33=Br-Bl

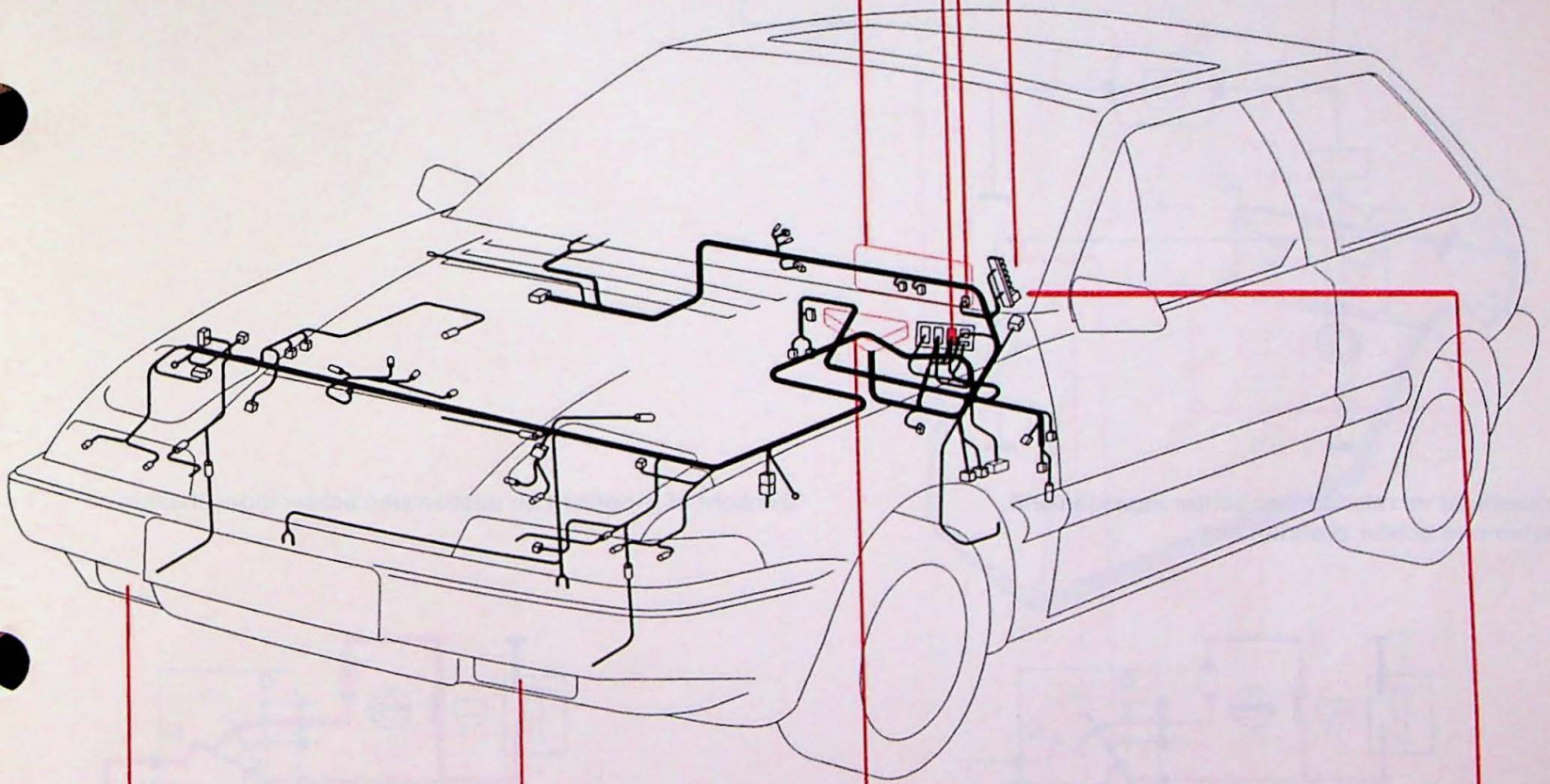

A19-A29



3.0

3.01

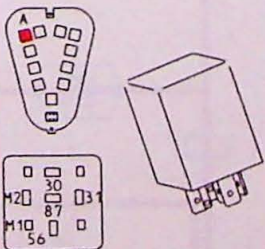

A = 1988

3.13

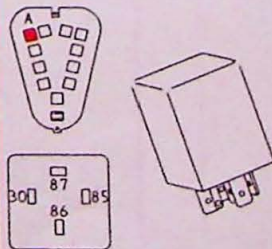

A = 1989

3.02/3.08

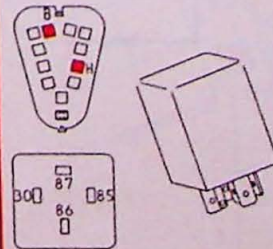

3.02 B = 1986-1987  
3.08 H = 1987-

C14

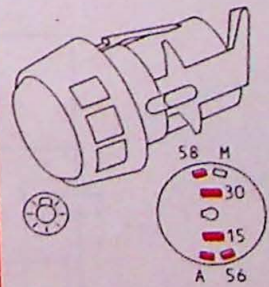

A = W  
15=W  
30=R  
56=Bl  
58=SB

# Mistachterlichten, Euro

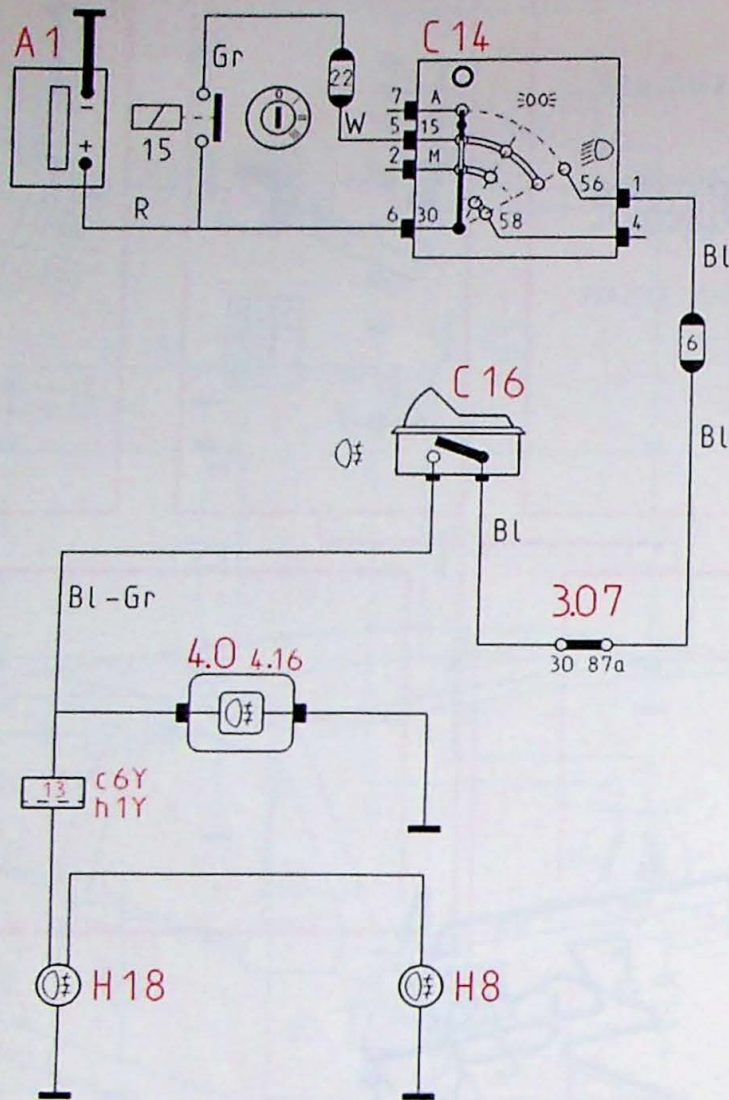

- 4.16 Controlelamp, mistachterlicht
- C14 Lichtschakelaar
- C16 Schakelaar mistachterlicht
- H8 Lamp mistachterlicht, rechts
- H18 Lamp mistachterlicht, links

(Opmerking: 3.07 is een brug)

Parkeerlicht en mistlampen achter ingeschakeld, mistlampen achter branden niet

Dimlicht of grootlicht en mistlampen achter ingeschakeld

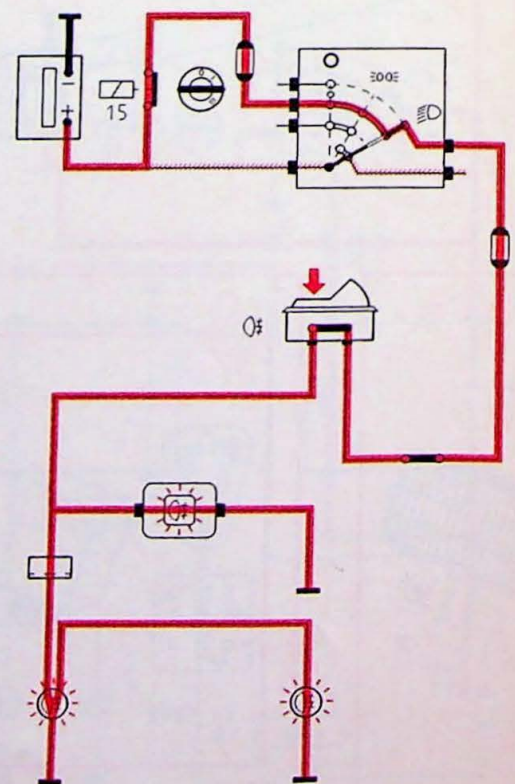
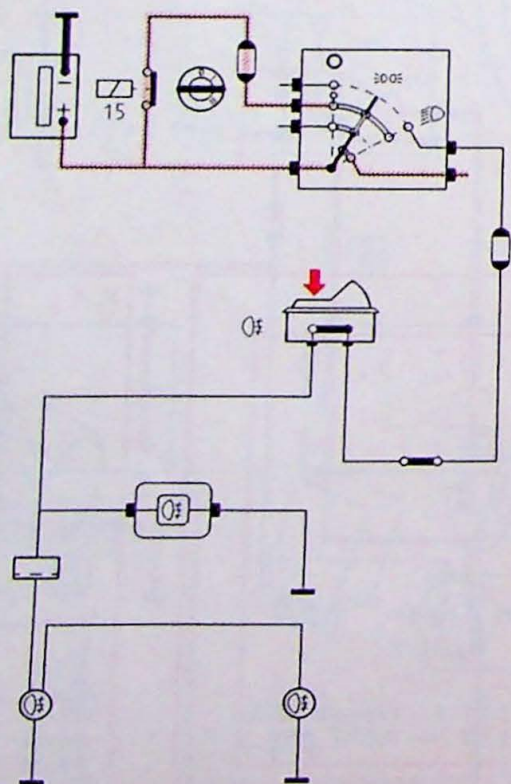

8-013/021

# Mistachterlichten, Euro

4.0

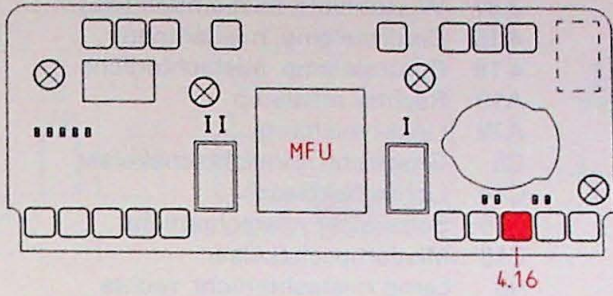

c6Y

c6Y ↔ h1Y

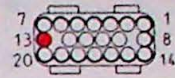

13=Bl-Gr H8,H18

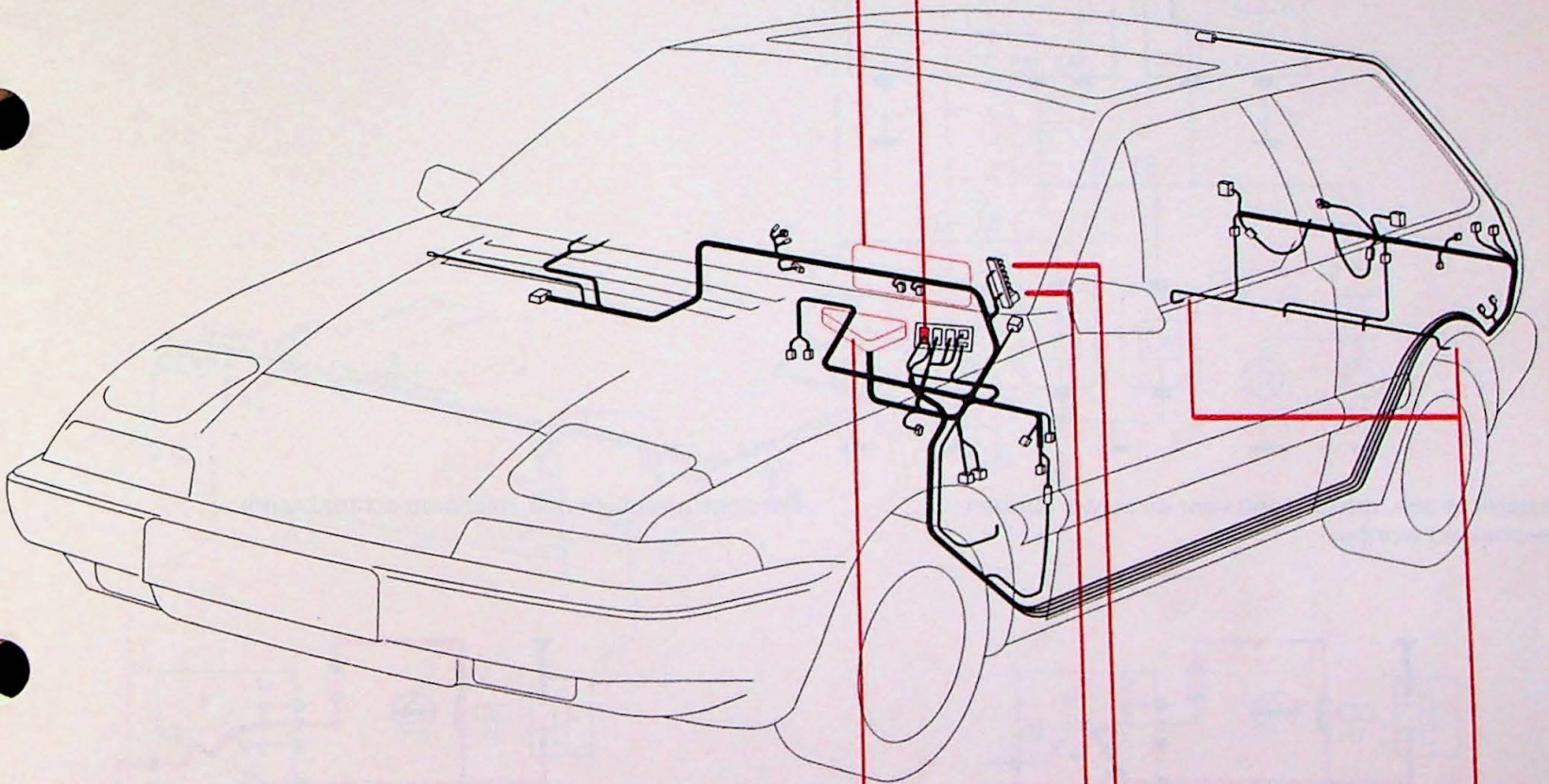

3.07

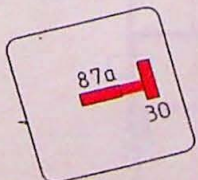
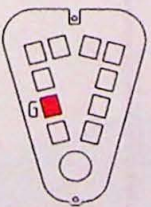

C 14

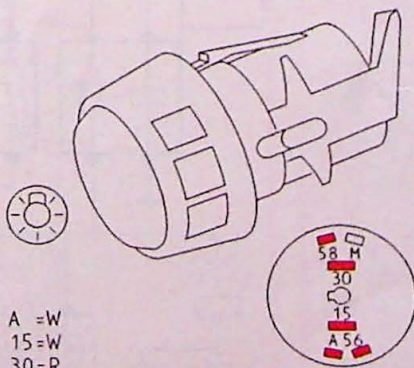

A = W  
15 = W  
30 = R  
56 = Bl  
58 = SB

C 16

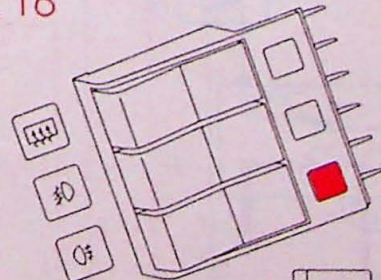

34 = Bl-Gr  
35 = Bl-Gr

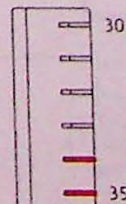

H8-H18

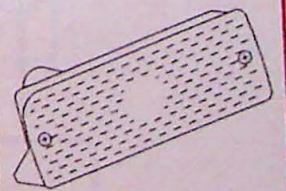

Bl-Gr  
Br



# Mistlampen voor en achter, NL

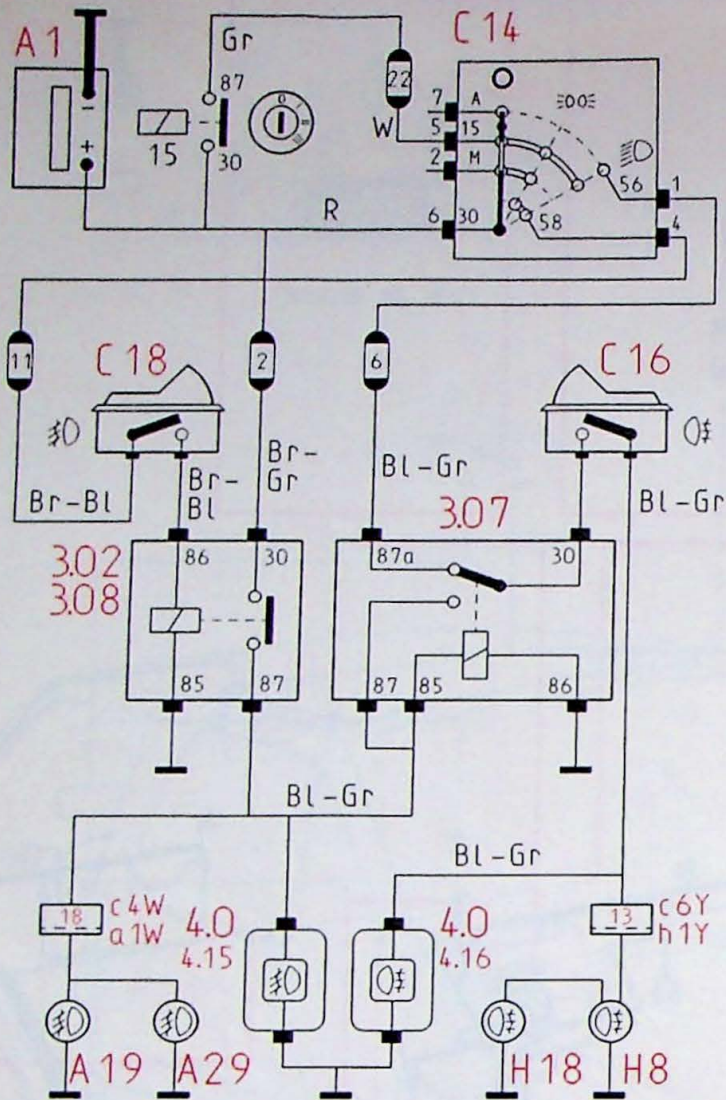

- 3.02 Relais, mistlampen
- 3.07 Wisselrelais, mistlampen (NL)
- 4.15 Controlelamp, mistlampen
- 4.16 Controlelamp, mistachterlicht
- A19 Rechter mistlamp
- A29 Linker mistlamp
- C5 Grootlicht-/dimlichtschakelaar
- C14 Lichtschakelaar
- C16 Schakelaar mistachterlicht
- C18 Mistlampschakelaar
- H8 Lamp mistachterlicht, rechts
- H18 Lamp mistachterlicht, links

Parkeerlicht aan, mistlampen voor en achter kunnen ingeschakeld worden

Dimlicht/grootlicht aan, mistlamp achter brandt

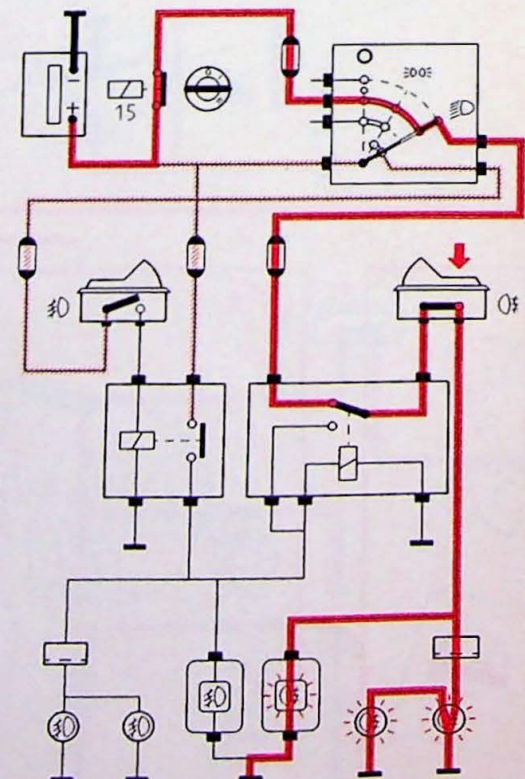
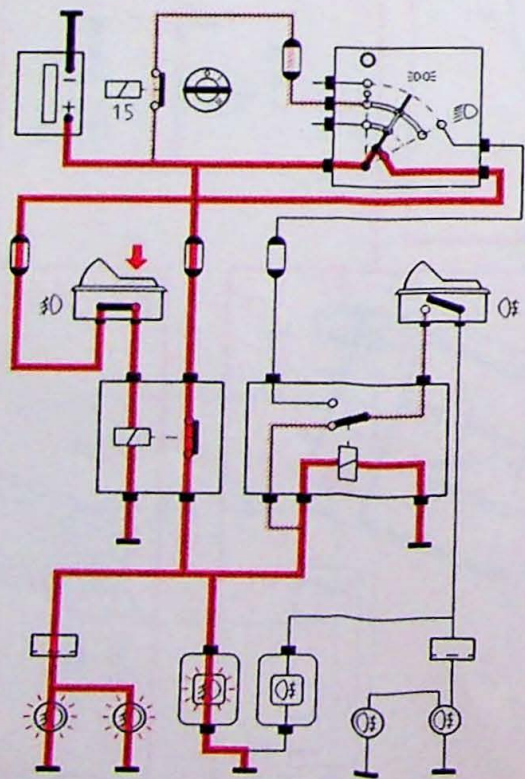

8-013/020

# Mistlampen voor en achter, NL

4.0

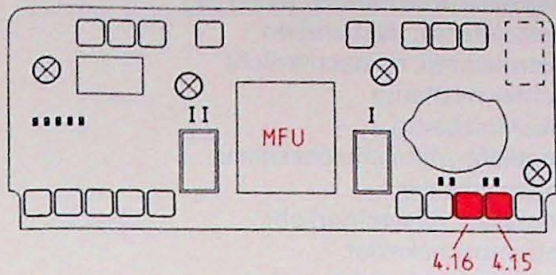

c6Y

c6Y ↔ h1Y

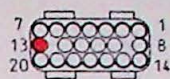

13=Bl-Gr H8, H18

c4W

c4W ↔ a1W



18=Bl-Gr A19, A29

C16-C18

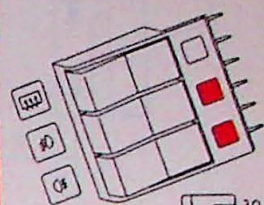

32=Br-Bl  
33=Br-Bl  
34=Bl-Gr  
35=Bl-Gr

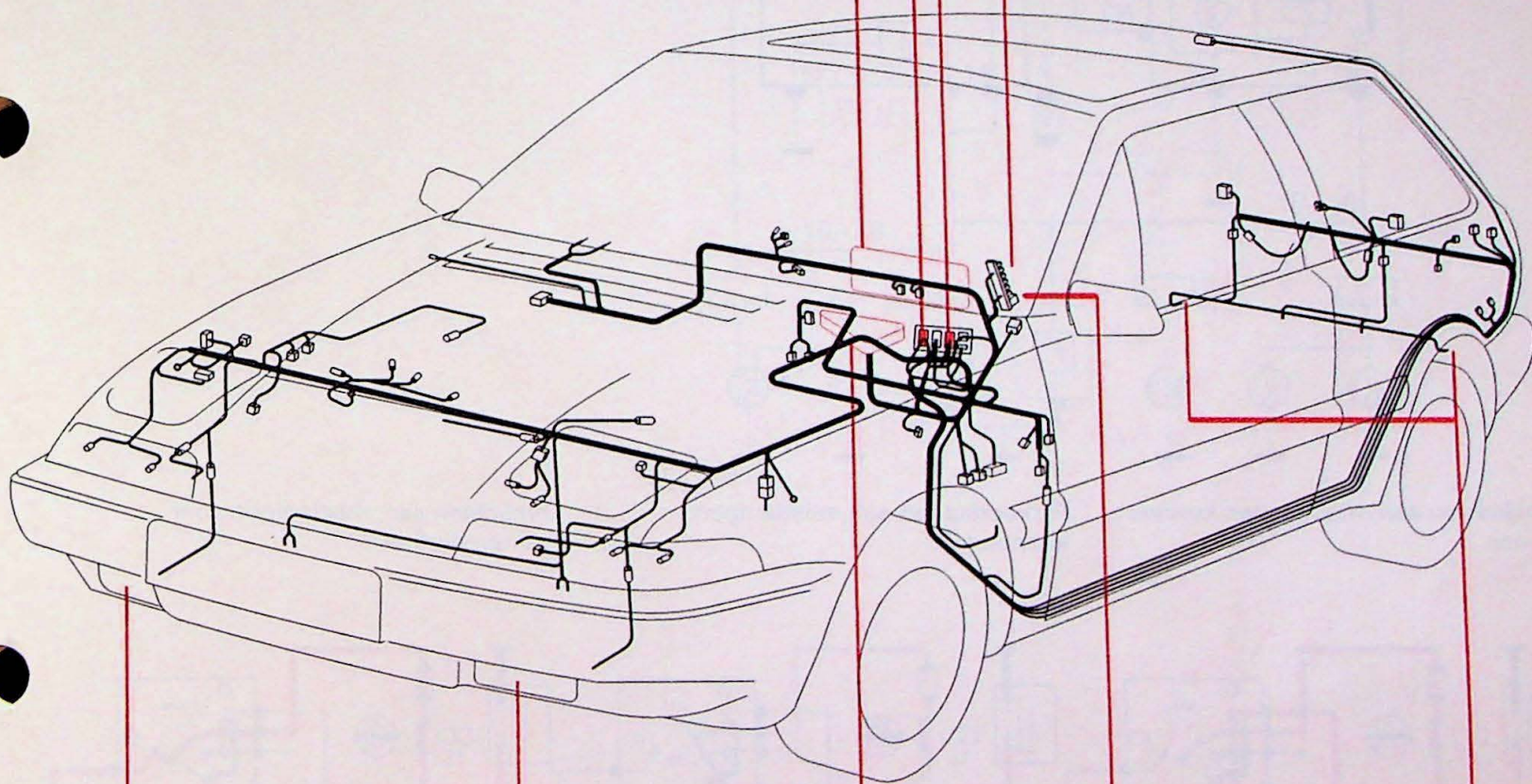

A19-A29

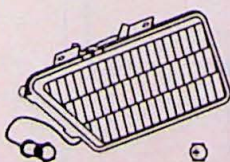

3.0

3.07

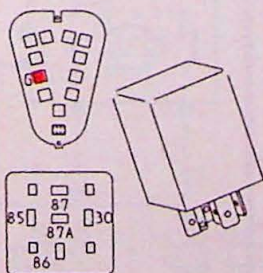

3.02/3.08

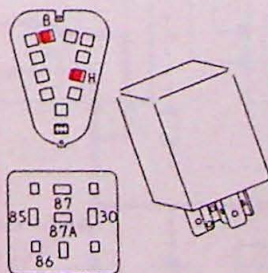

3.02 B = 1986-1987  
3.08 H = 1987-

C14

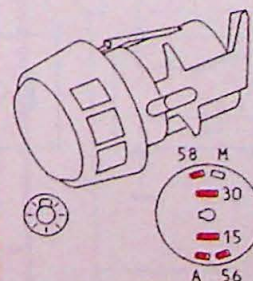

A = W  
15 = W  
30 = R  
56 = Bl  
58 = SB

H8-H18

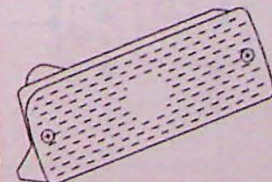

Bl-Gr  
Bn



# Mistlampen voor en achter, N en SF

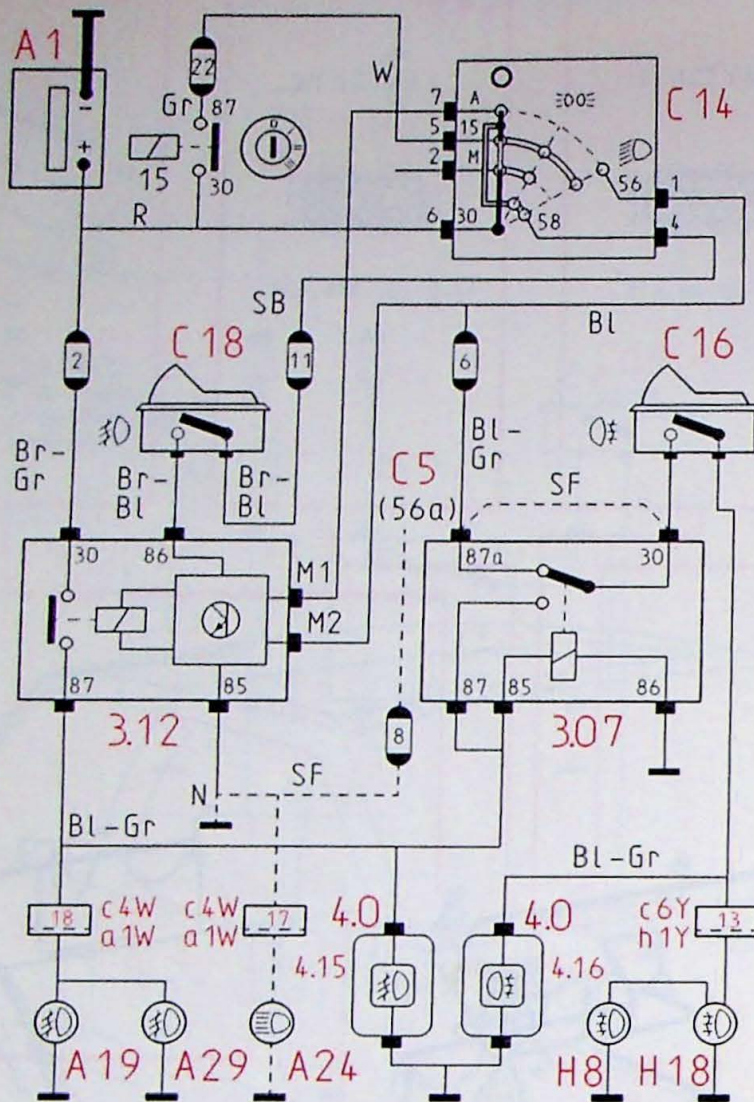

- 3.07 Wisselrelais, mistlampen (N en SF)
- 3.12 Sperrelais, mistlampen (N en SF)
- 4.15 Controlelamp, mistlampen
- 4.16 Controlelamp, mistachterlicht
- A19 Rechter mistlamp
- A29 Linker mistlamp
- C5 Grootlicht-/dimlichtschakelaar
- C14 Lichtschakelaar
- C16 Schakelaar mistachterlicht
- C18 Mistlampschakelaar
- H8 Lamp mistachterlicht, rechts
- H18 Lamp mistachterlicht, links

Dagrijlichten aan, mistlampen kunnen niet aan

Parkeerlichten aan, mistlampen kunnen aan

Dimlichten aan, mistlampen vóór kunnen niet aan

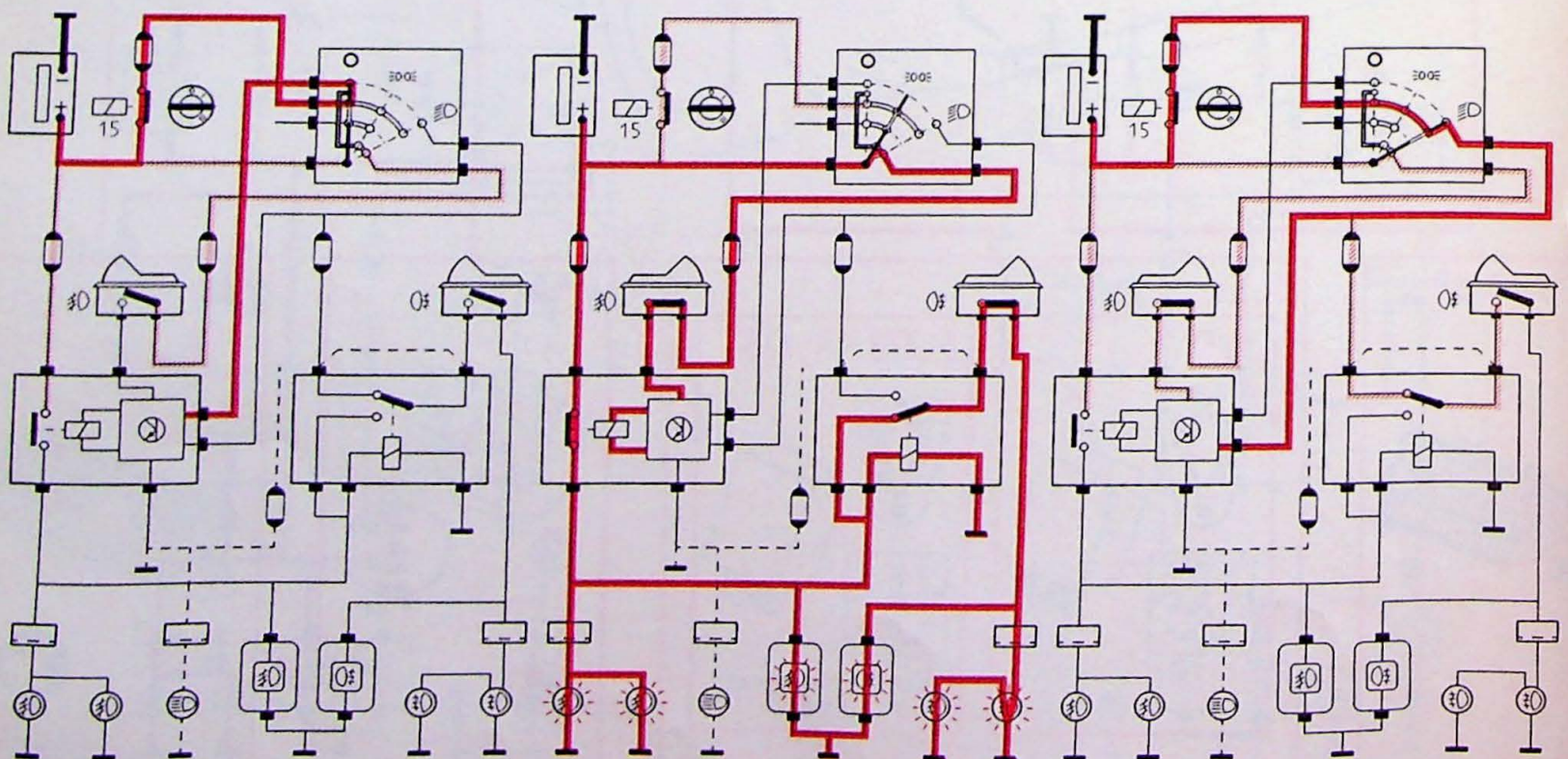

8-013/019

# Mistlampen voor en achter, N en SF

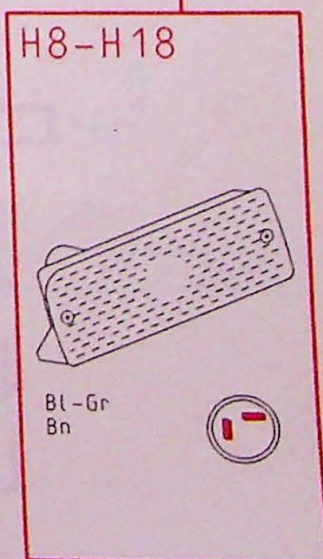
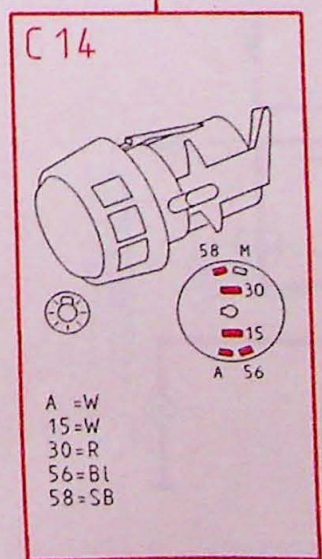
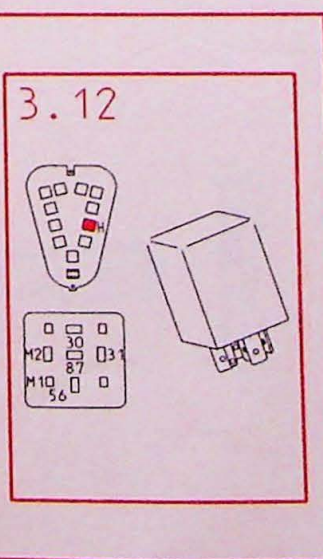
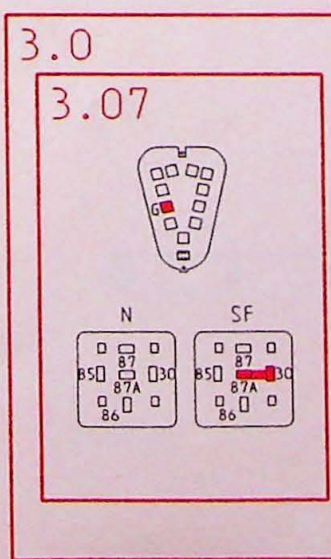
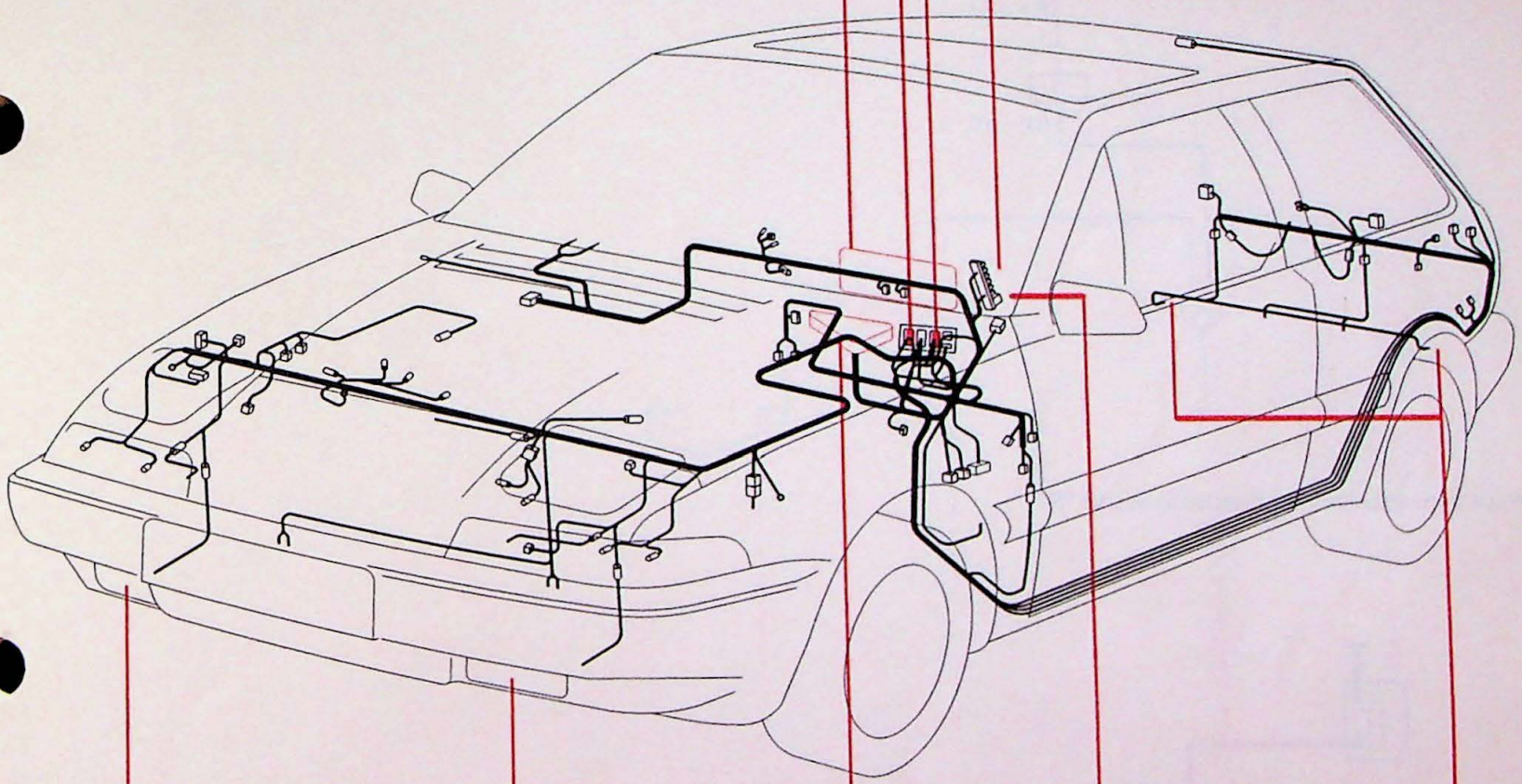
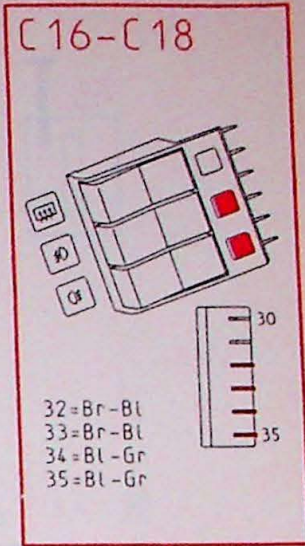
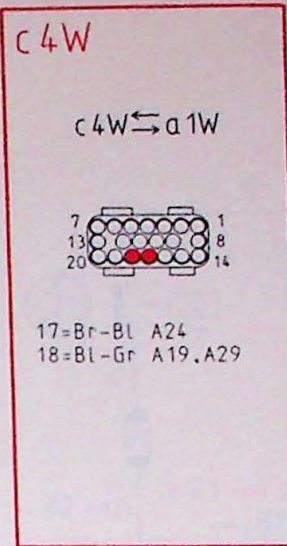
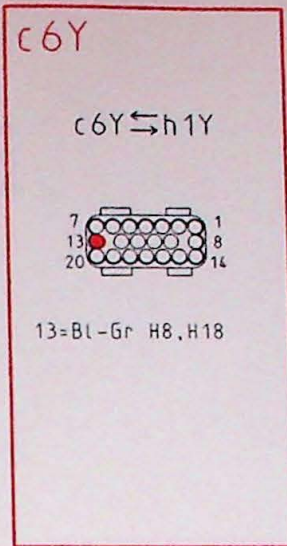
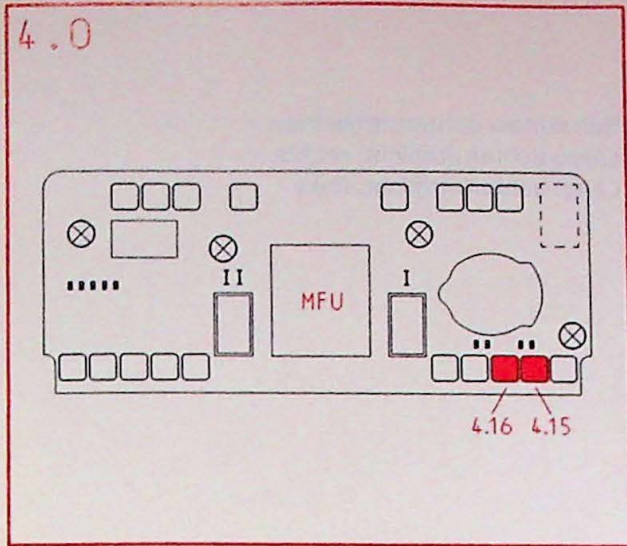

# Achteruitrijlichten

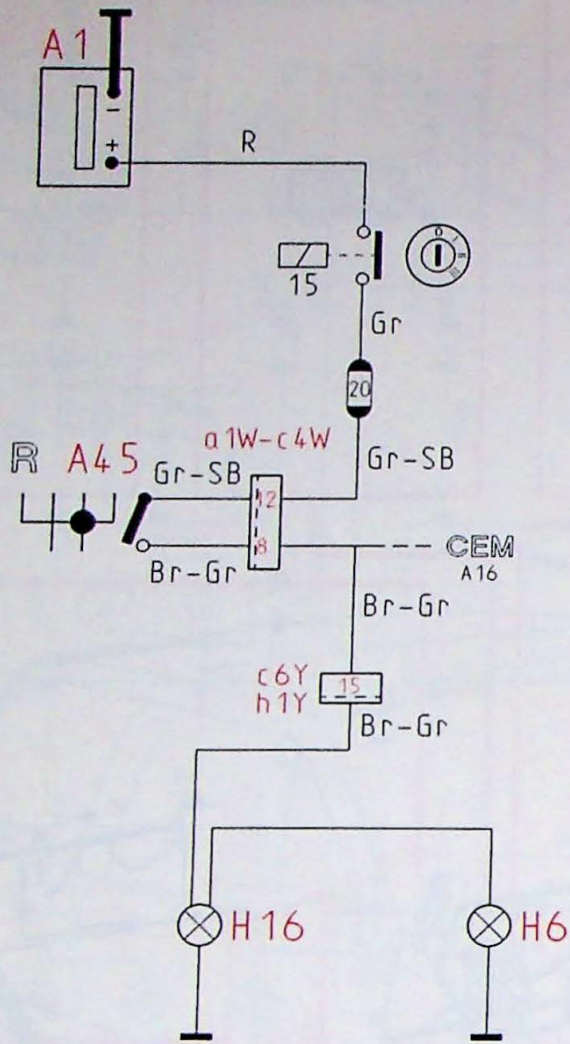

- A45 Schakelaar achteruitrijlichten
- H6 Lamp achteruitrijlicht, rechts
- H16 Lamp achteruitrijlicht, links

Contact aan, versnellingshendel in stand "R"

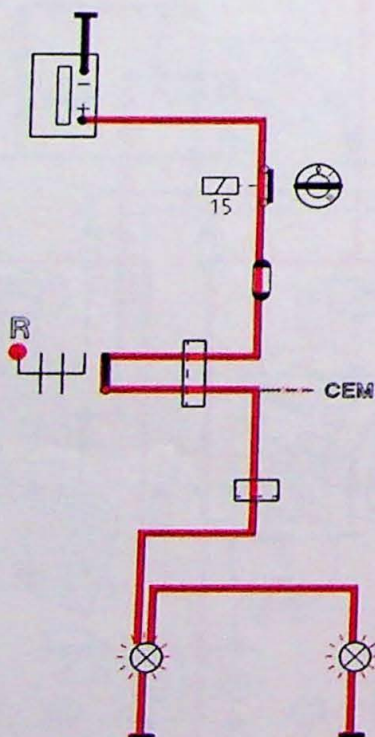

8-013/014

# Achteruitrijlichten

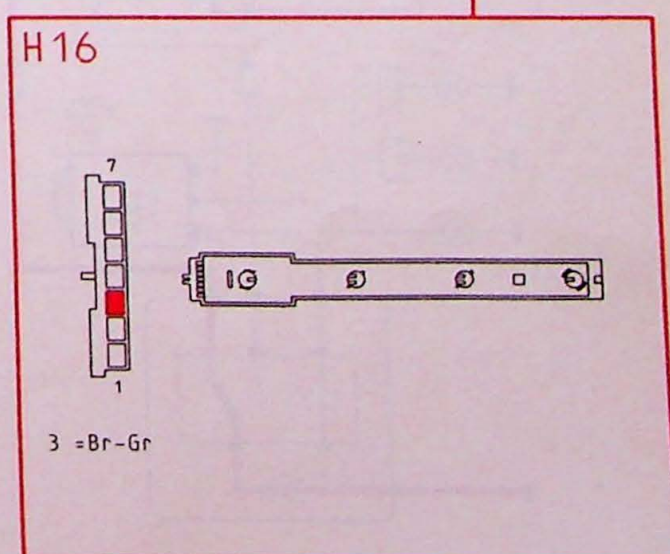
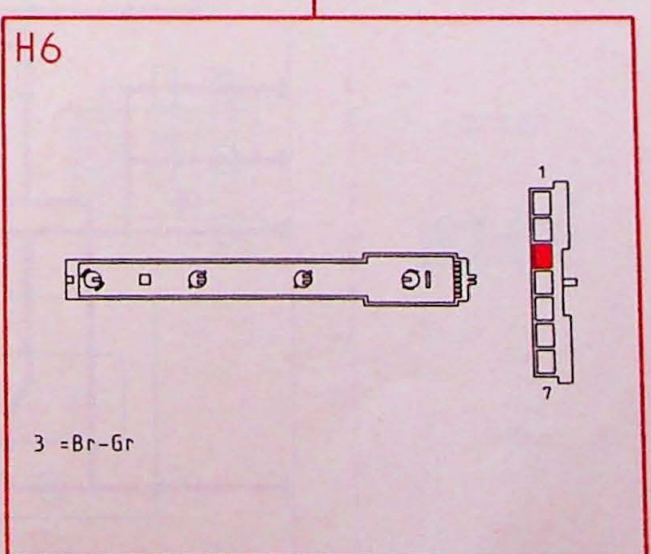
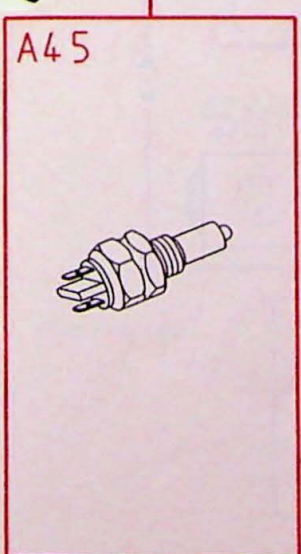
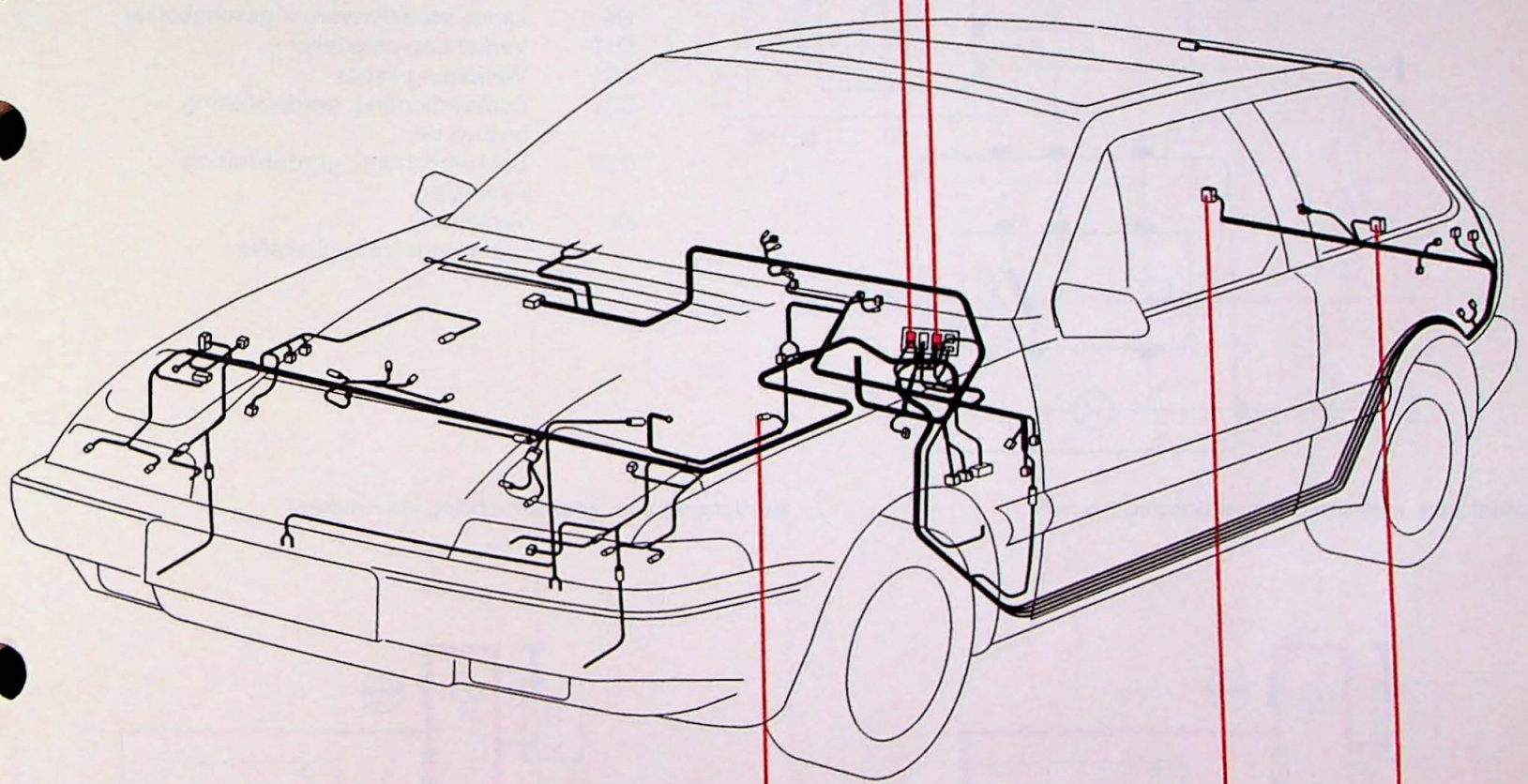
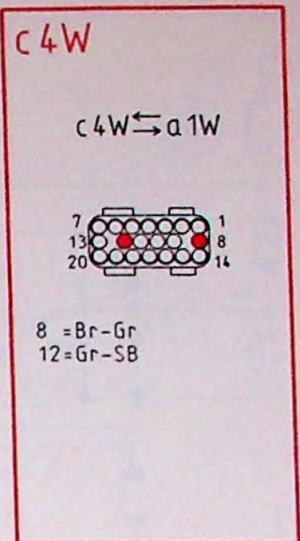
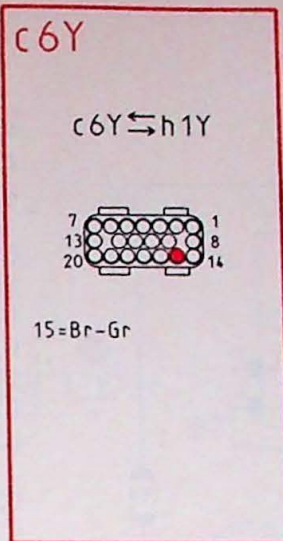

# Instrumentenverlichting

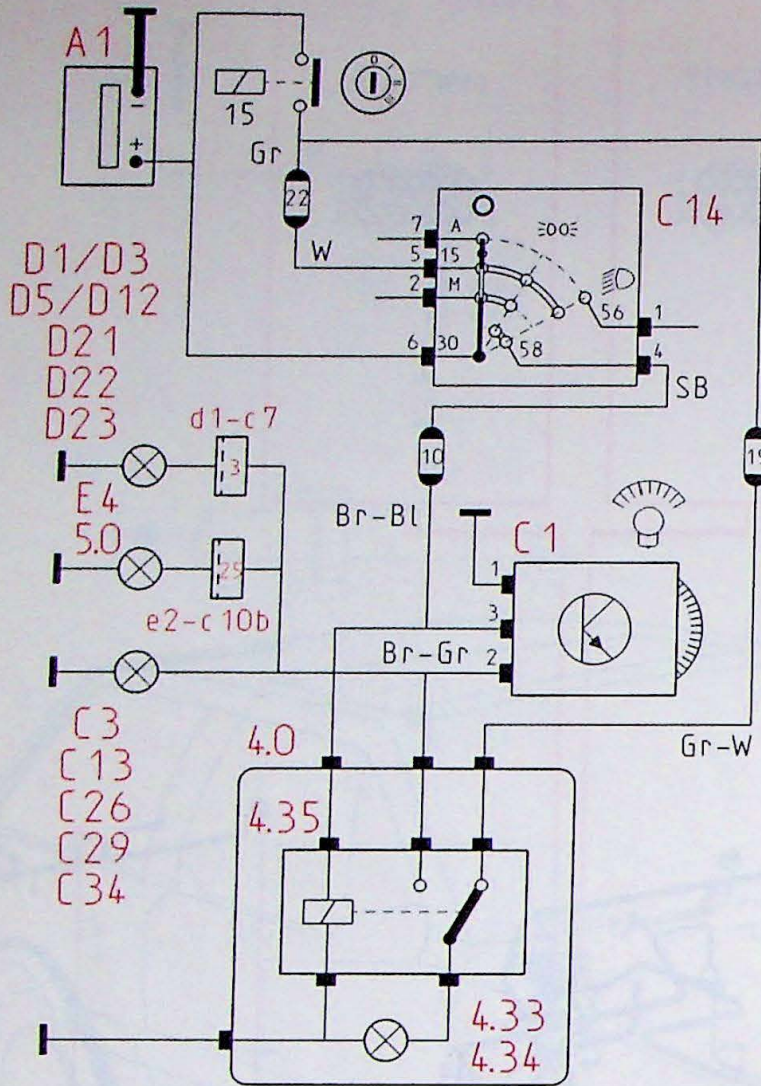

- 4.33 LCD verlichting, informatiecentrum
- 4.34 Verlichting, instrumentenpaneel
- 4.35 15/30 Voedingsrelais, instrumentenverlichting
- 5.0 VEM
- C1 Dimmer dashboardverlichting
- C3 Schakelaar waarschuwingslichten
- C13 Digitale klok
- C14 Lichtschakelaar
- C26 Verlichting, radio
- C29 Verlichting, centrale instrumentenpaneel
- C32,33 Oliedrukmeter/accuvoltmeter
- C34 Verlichting, lichtschakelaar
- D1 Zoekverlichting middenconsole schakelaars
- D3 Lamp, stoelverwarmingsschakelaar
- D5 Lamp, stoelverwarmingsschakelaar
- D12 Verlichting aansteker
- D21 Verlichting asbak
- D22 Zoekverlichting, gordelsluiting bestuurder
- D23 Zoekverlichting, gordelsluiting passagier
- E4 Verlichting, kachelventilatorschakelaar

Contact aan, instrumentenverlichting brandt

Verlichting aan, zoekverlichting via reostaat

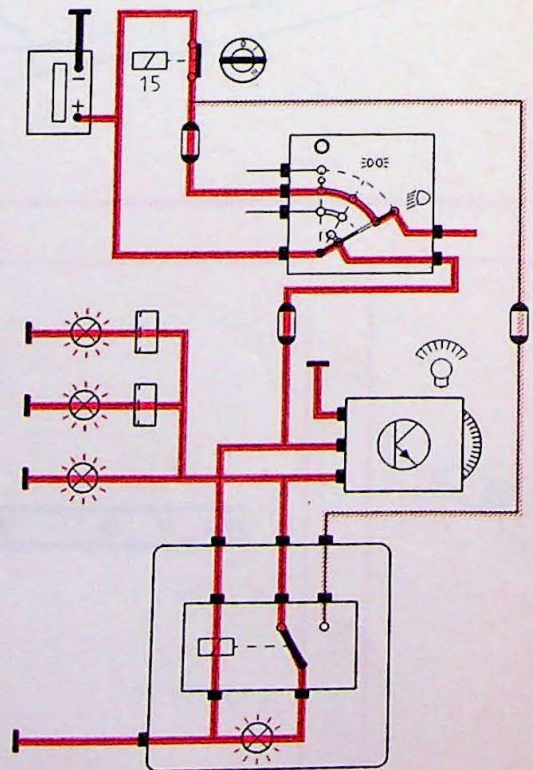
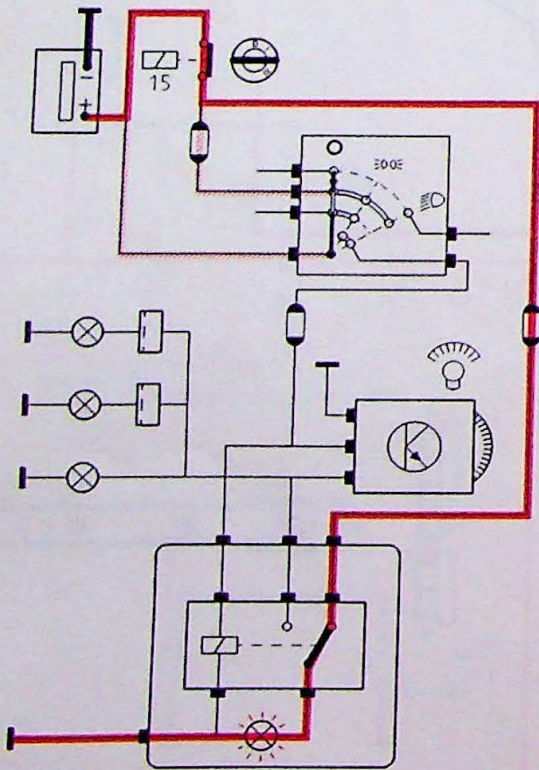

8-013/037

# Instrumentenverlichtung

4.0

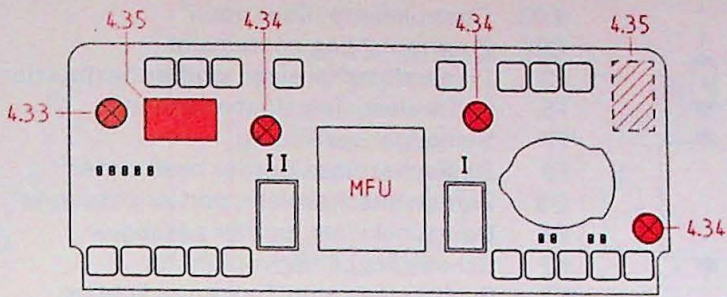

C 1

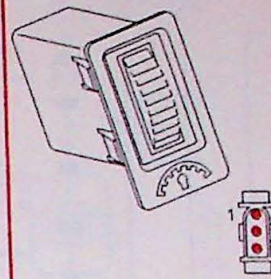

- 1 = Br
- 2 = Br-Gr
- 3 = Br-Bl

C 14

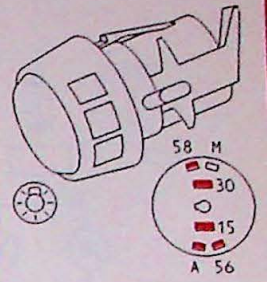

- A = W
- 15 = W
- 30 = R
- 56 = Bl
- 58 = SB

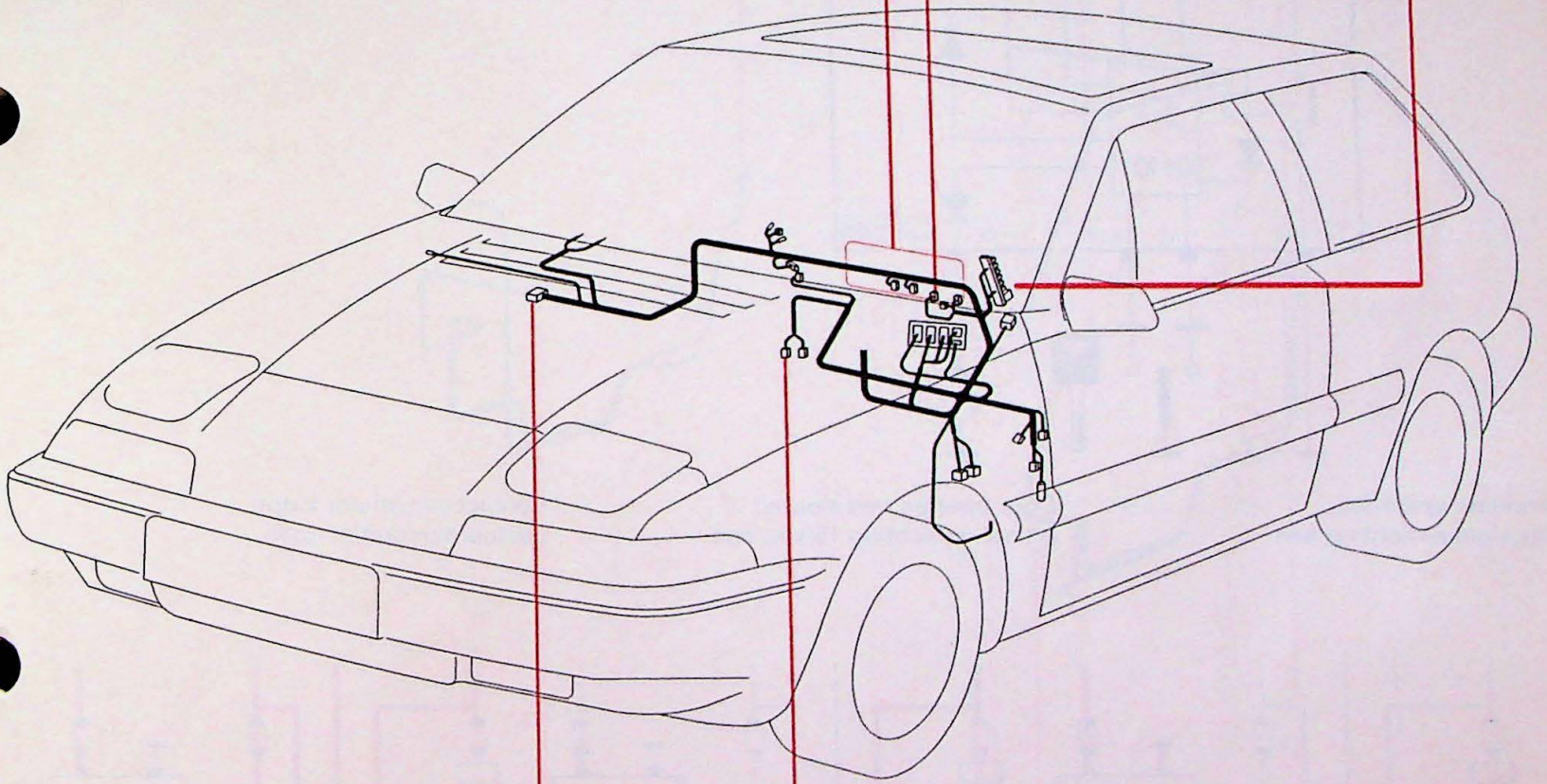

c 10 (b)

c 10 (b) ↔ e 2 (b)

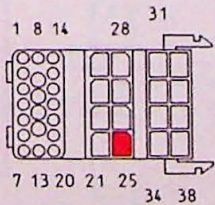

- 25 = Br-Gr E4
- 5.0

c 7

c 7 ↔ d 1

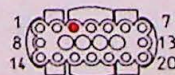

- 3 = Br-Gr D1
- D3
- D5
- D12
- D21
- D22
- D23

# Binnenverlichting en sleutelgatverlichting

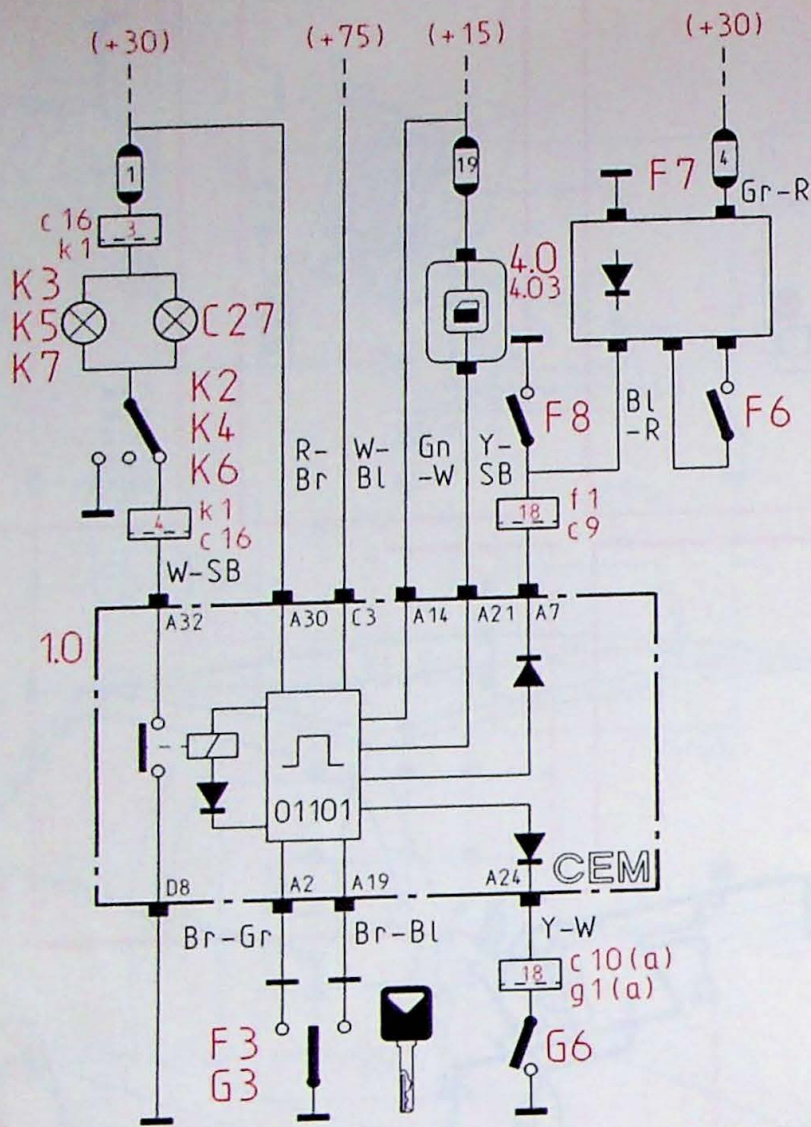

- 4.03 Controlelamp "deur open"
- C27 Zoekverlichting contactslot
- F3 Portierslotschakelaar, portier bestuurder
- F6 Schakelaar sleutelgatverlichting
- F7 Sleutelgat-verlichting
- F8 Deurschakelaar, portier bestuurder
- G3 Portierslotschakelaar, portier passagier
- G6 Deurschakelaar, portier passagier
- K2 Schakelaar binnenverlichting
- K7 Rechter leeslamp, binnenverlichting

Deurklink oplichten,  
sleutelgatverlichting aan

Deur openen met sleutel,  
binnenverlichting 15 sec. aan

Contact aan, motor loopt,  
bestuurdersportier open

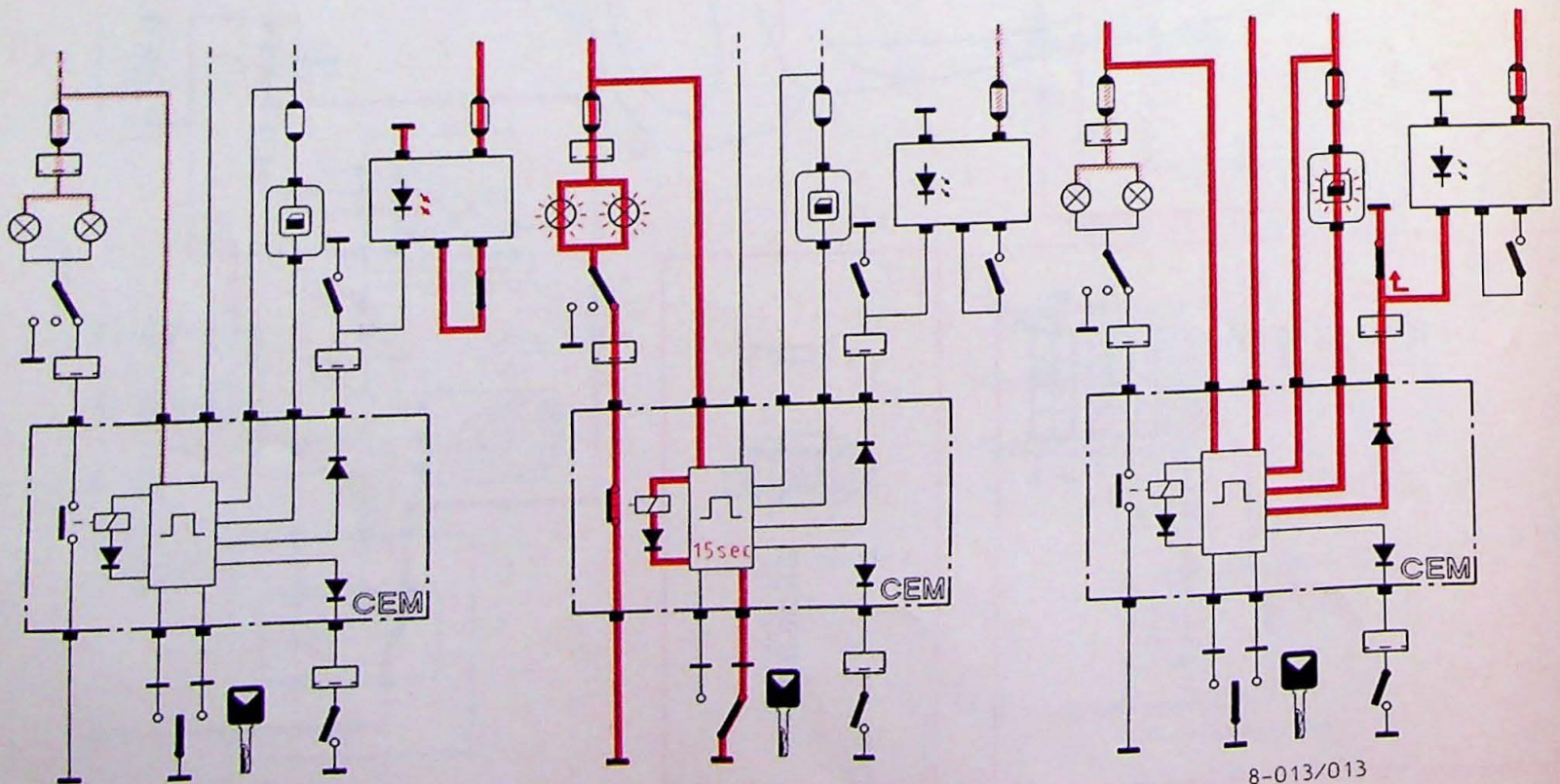

8-013/013

# Binnenverlichting en sleutelgatverlichting

F3 - G3

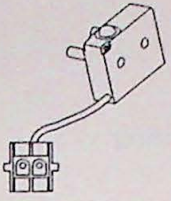

4.0

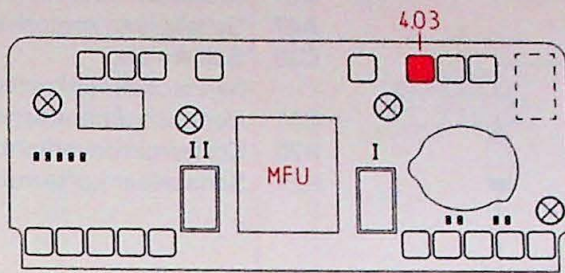

c 16

c 16 ↔ k 1

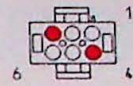

3 = R-Br  
4 = W-SB

K2  
K3  
K4  
K5  
K6  
K7

F6 - F7

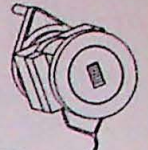

1 = Br  
2 = Bl-R  
3 = Gr-R

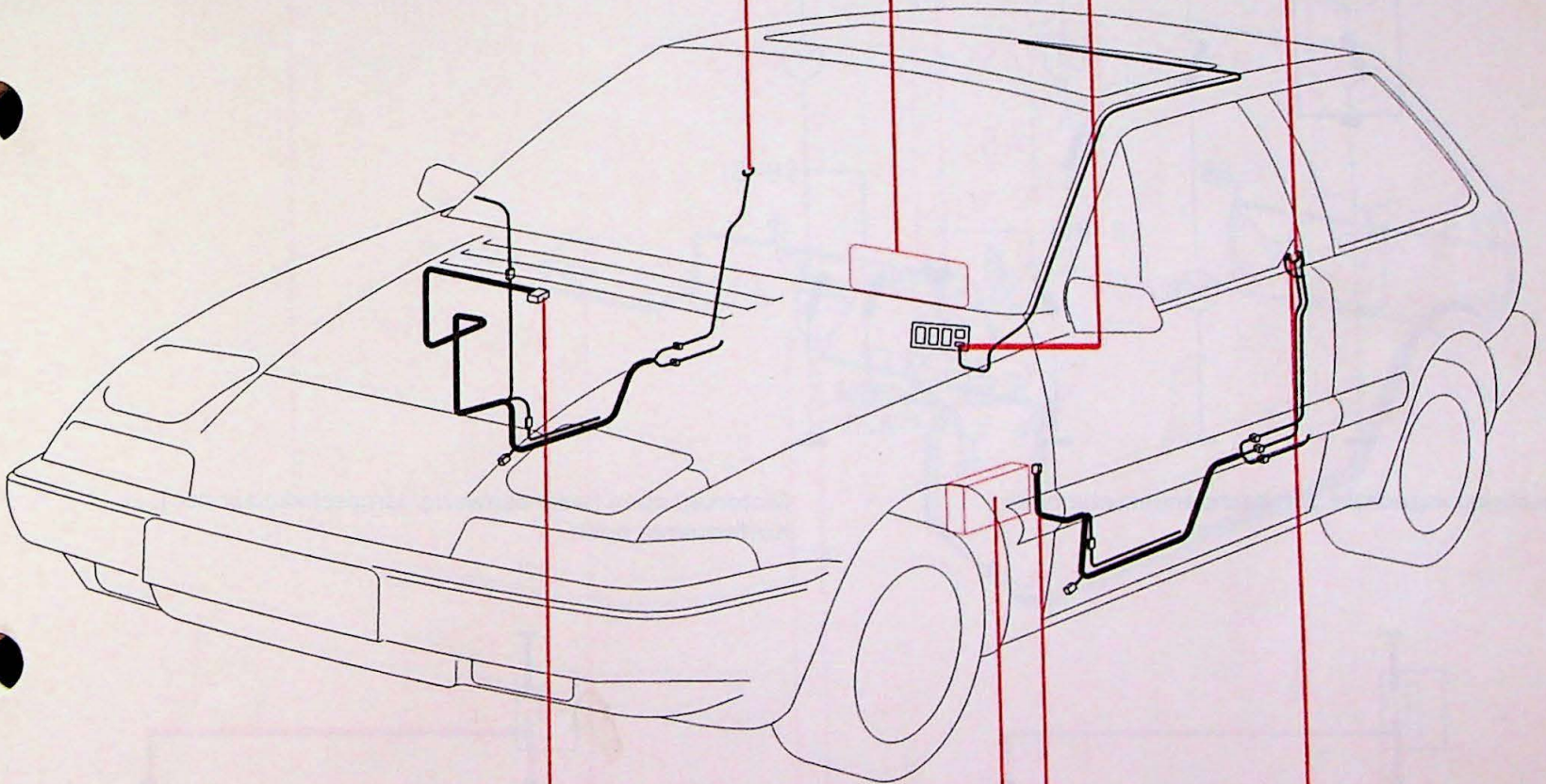

c 10 (a)

c 10 (a) ↔ g 1 (a)

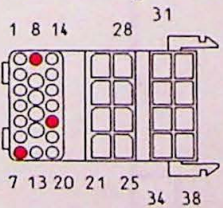

7 = Br-Gr G3-1.0  
8 = Br-Bl G3-1.0  
18 = Y-W G6-1.0

1.0

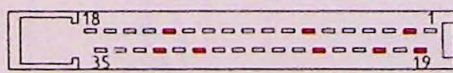

A

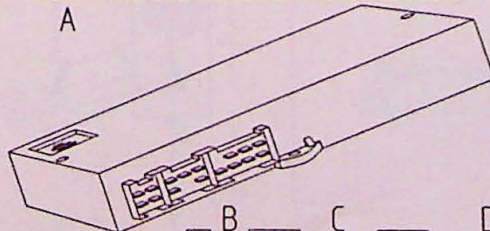

A2 = Br-Gr  
A7 = Bl-R  
A14 = Gn-W  
A19 = Br-Bl  
A21 = Y-SB  
A24 = Y-W

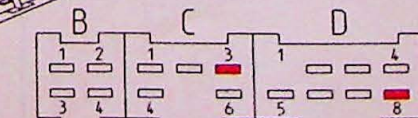

A30 = R  
A32 = W-SB  
C3 = W-Bl  
D8 = Br

c 9

c 9 ↔ f 1

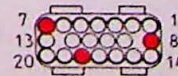

7 = Br-Gr F3-1.0  
8 = Br-Bl F3-1.0  
18 = Bl-R F8-1.0

F8 - G6

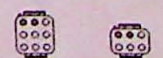
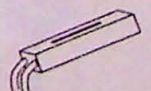

F8  
1 = Bl-R  
2 = Br

G6  
1 = Y-W  
2 = Br

# Verlichting handschoenenkastje, motor, aansteker

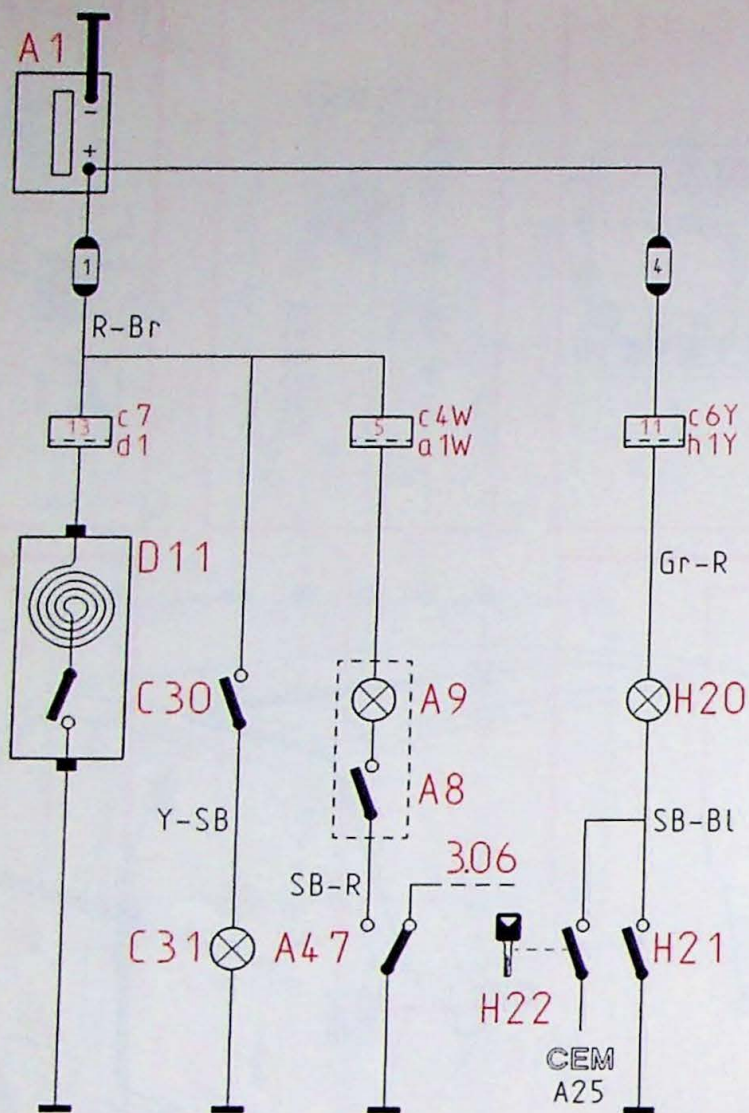

- A9 Motorruimteverlichting
- A47 Schakelaar, motorkapslot
- C30 Schakelaar, handschoenenkastverlichting
- C31 Handschoenenkastverlichting
- H20 Kofferruimteverlichting
- H21 Schakelaar kofferruimteverlichting

Aansteker ingedrukt. Handschoenenkastje open

Motorkap open (waar aanwezig: lamschakelaar aan).  
Kofferruimte open

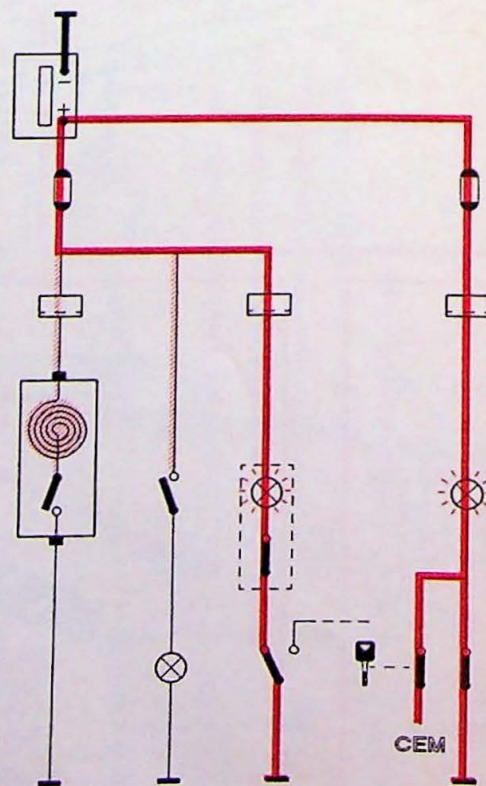
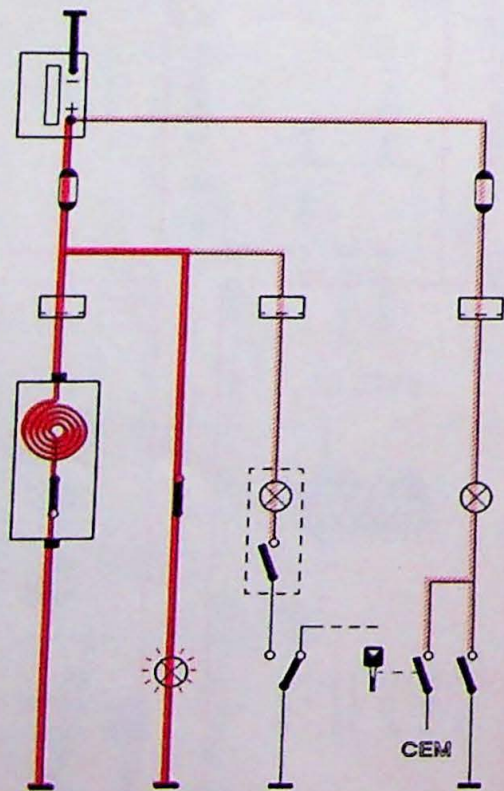

8-013/011

# Verlichting handschoenenkastje, motor, aansteker

a19

a19 → A47



1 = SB-R  
2 = Br  
3 = SB

c6Y

c6Y ↔ h1Y

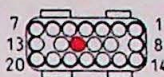

11 = Gr-R

c4W

c4W ↔ a1W

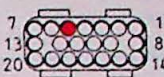

5 = R-Br

H20  
H21

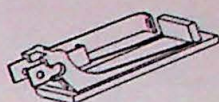
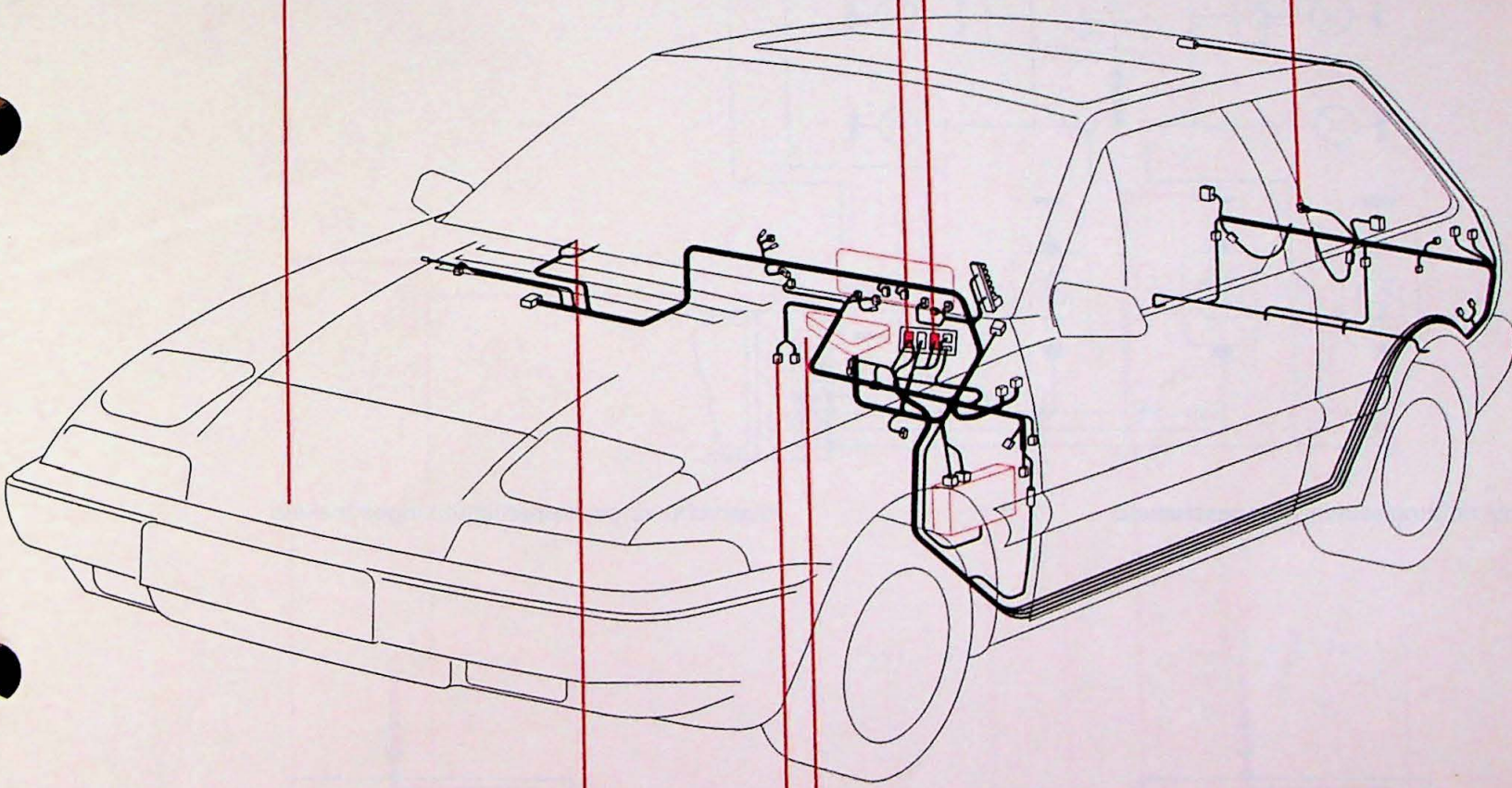

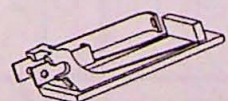

C30  
C31



c7

c7 ↔ d1



13 = R-Br

D11

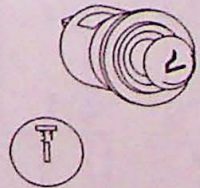

# Verlichting handschoenenkastje, motor, aansteker

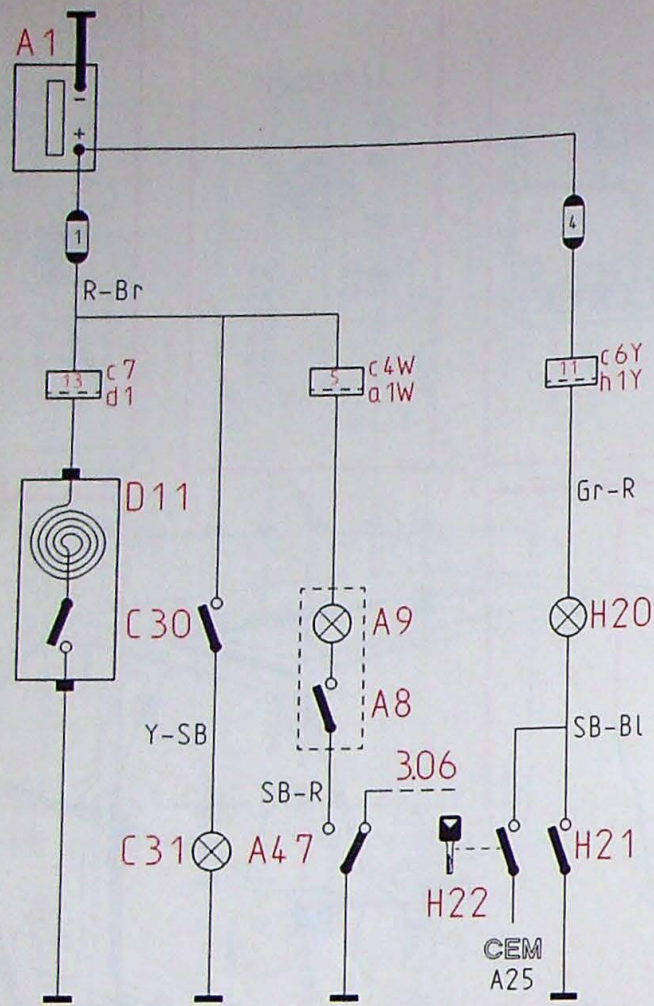

- A9 Motorruimteverlichting
- A47 Schakelaar, motorkapslot
- C30 Schakelaar, handschoenenkastverlichting
- C31 Handschoenenkastverlichting
- H20 Kofferruimteverlichting
- H21 Schakelaar kofferruimteverlichting

Aansteker ingedrukt. Handschoenenkastje open

Motorkap open (waar aanwezig: lampschakelaar aan). Kofferruimte open

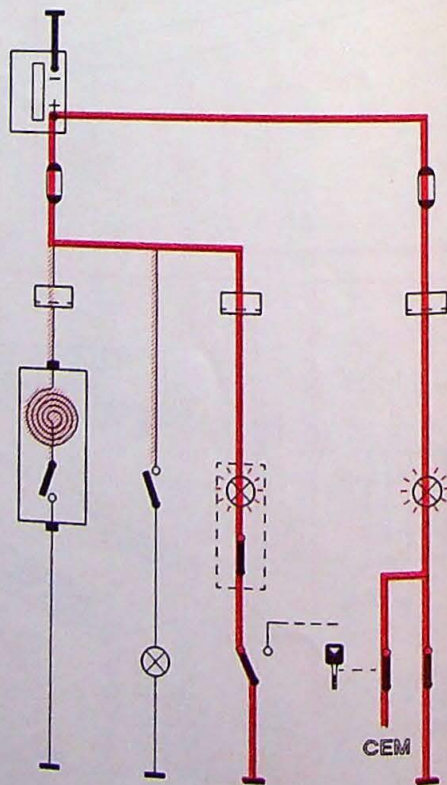
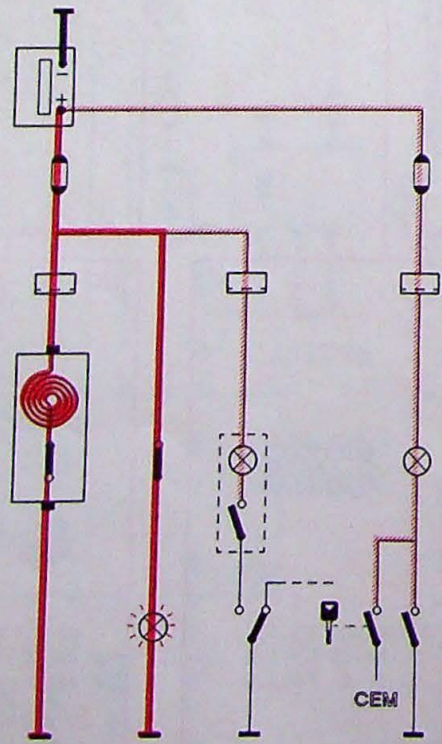

8-013/011

# Verlichting handschoenenkastje, motor, aansteker

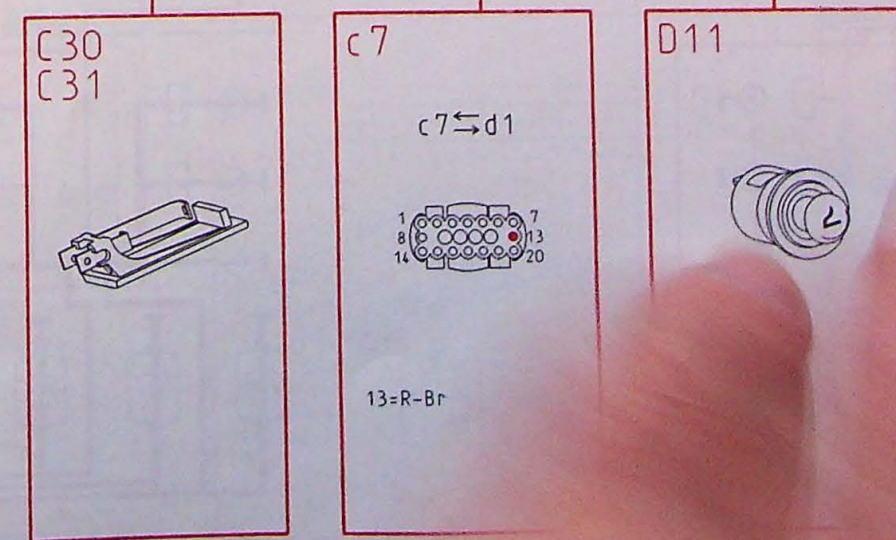
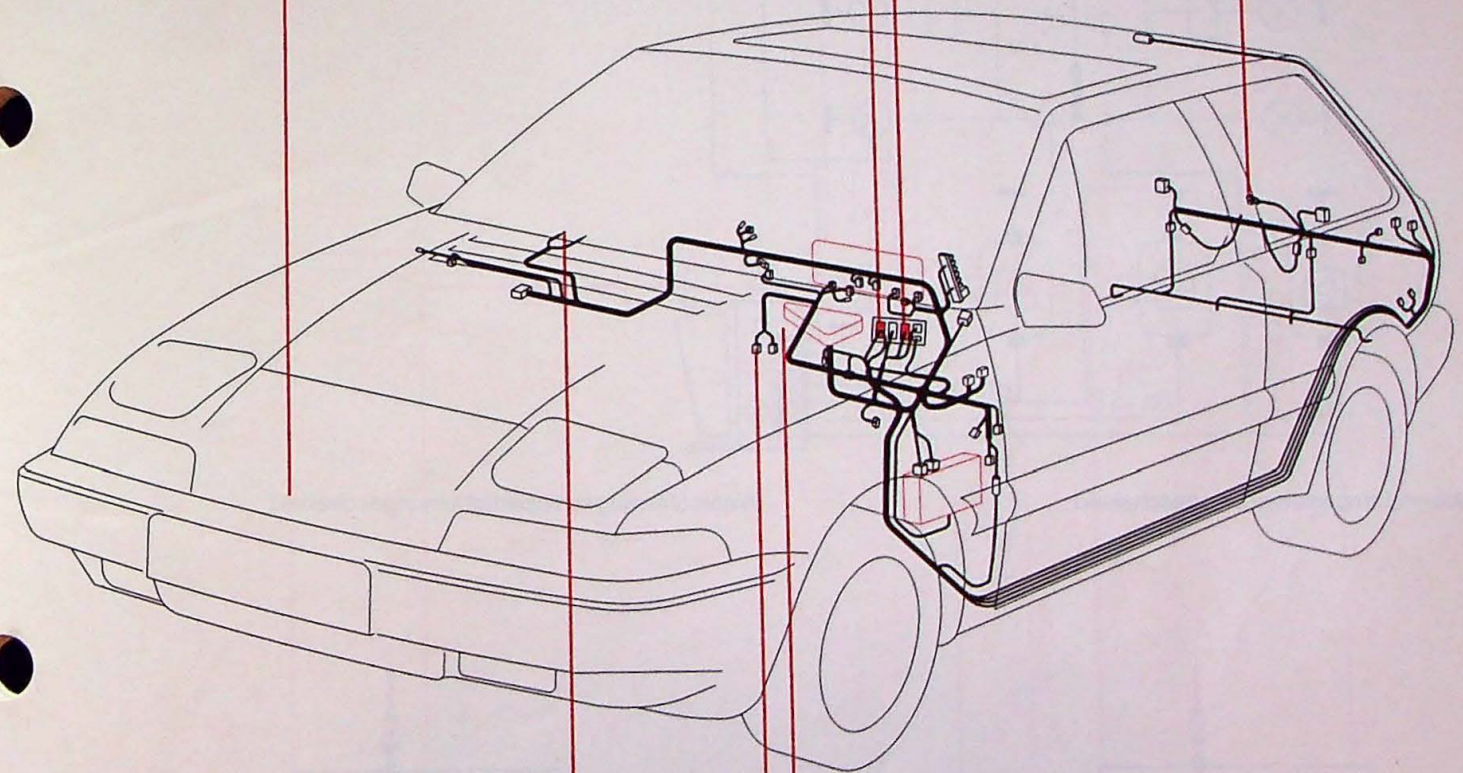
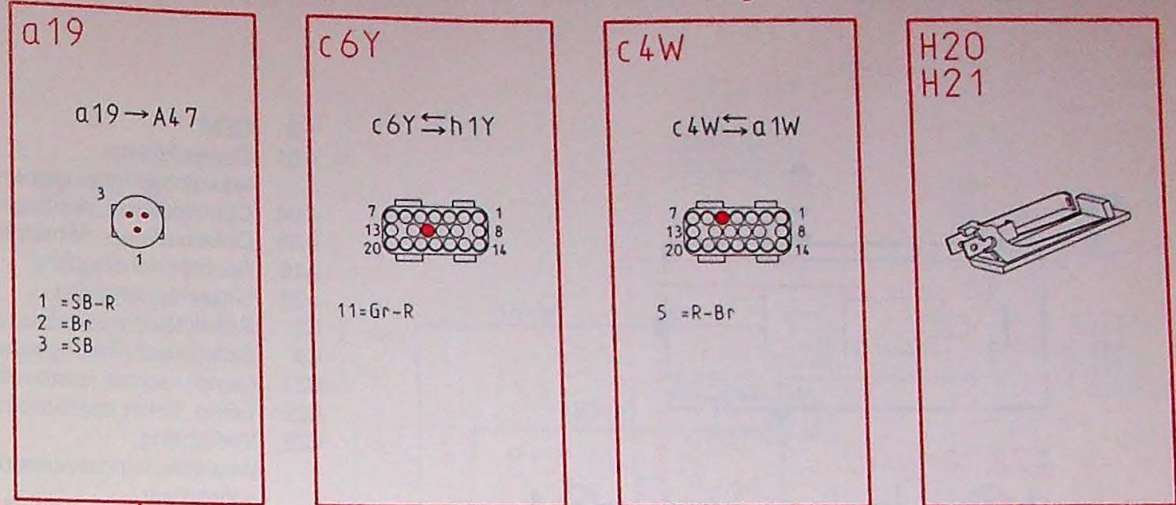

# Verlichting handschoenenkastje, motor, aansteker

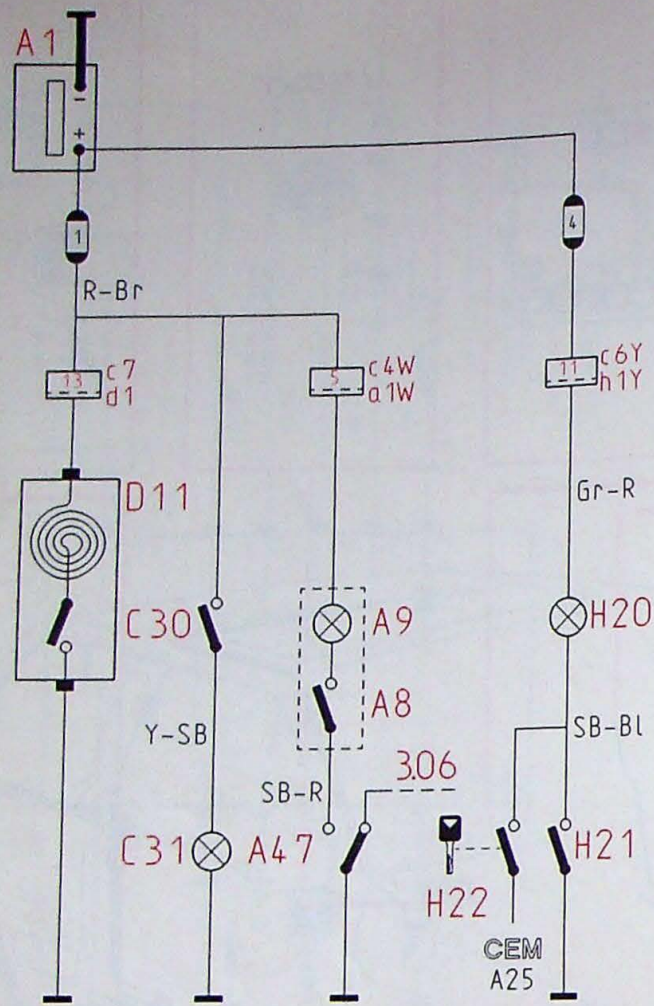

- A9 Motorruimteverlichting
- A47 Schakelaar, motorkapslot
- C30 Schakelaar, handschoenenkastverlichting
- C31 Handschoenenkastverlichting
- H20 Kofferruimteverlichting
- H21 Schakelaar kofferruimteverlichting

Aansteker ingedrukt. Handschoenenkastje open

Motorkap open (waar aanwezig: lampschakelaar aan). Kofferruimte open

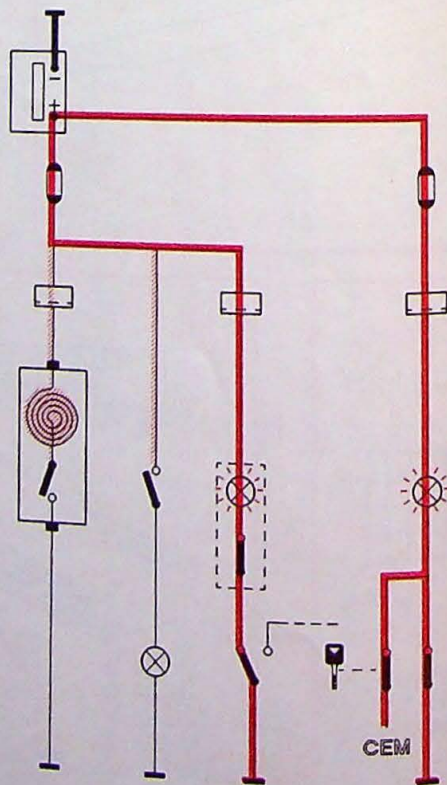
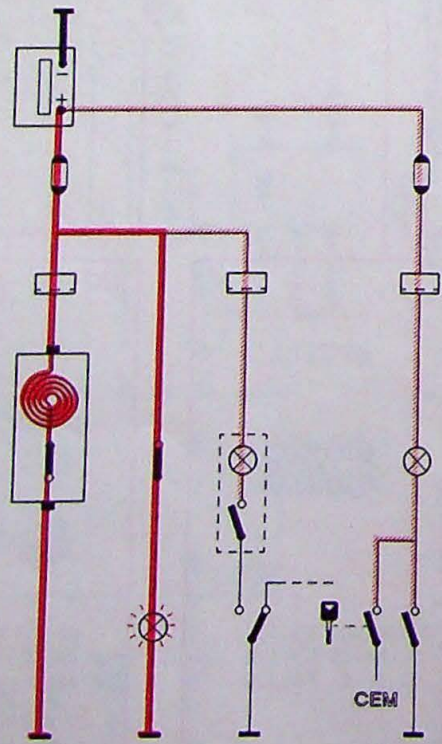

8-013/011

# Verlichting handschoenenkastje, motor, aansteker

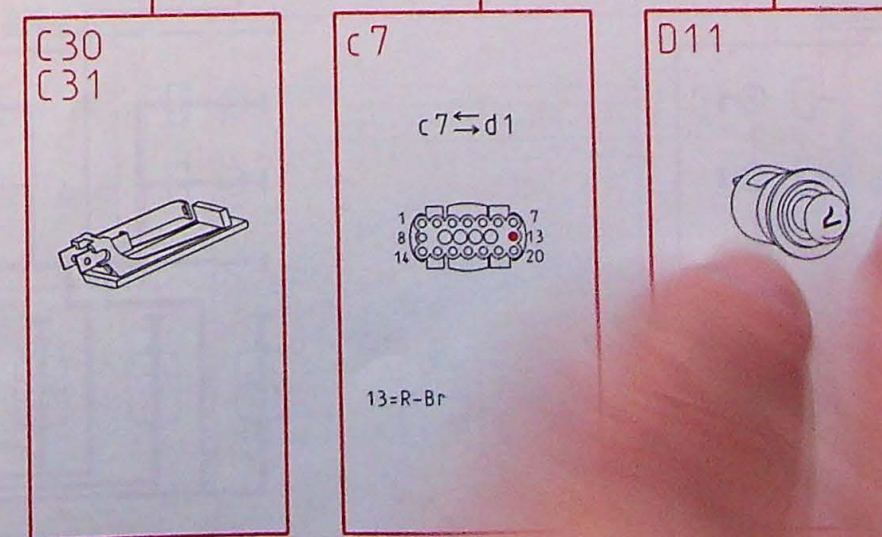
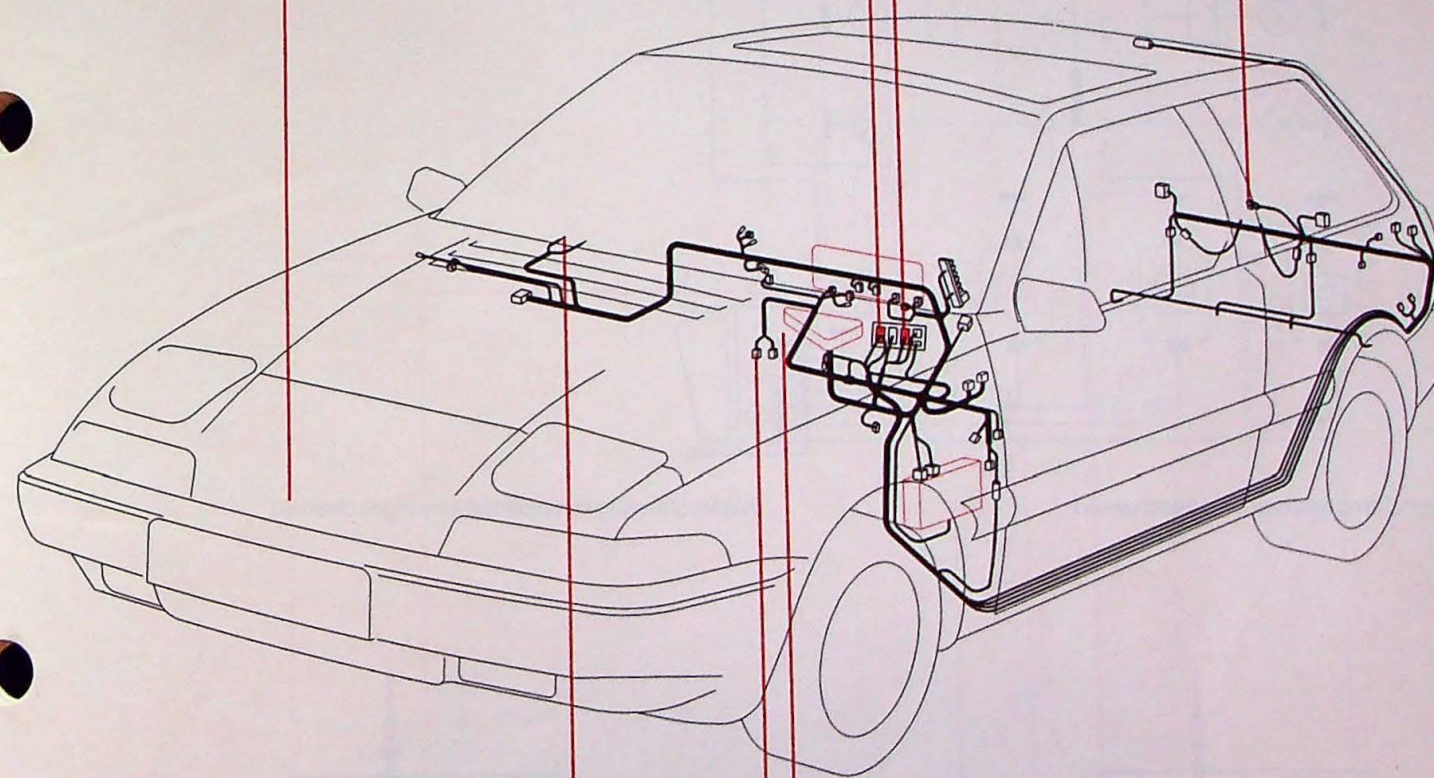
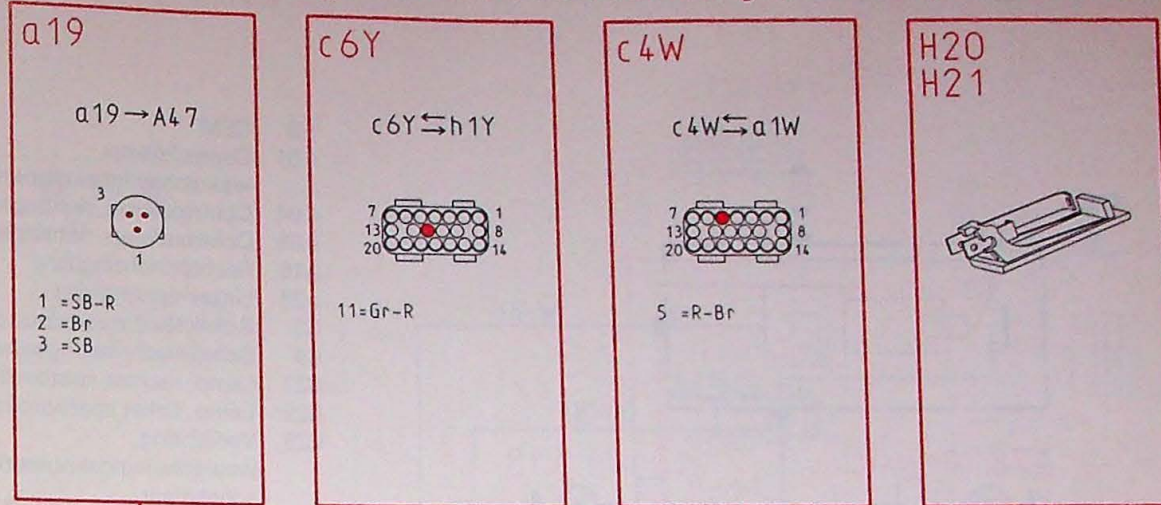

# Ruitwissers, voorruit

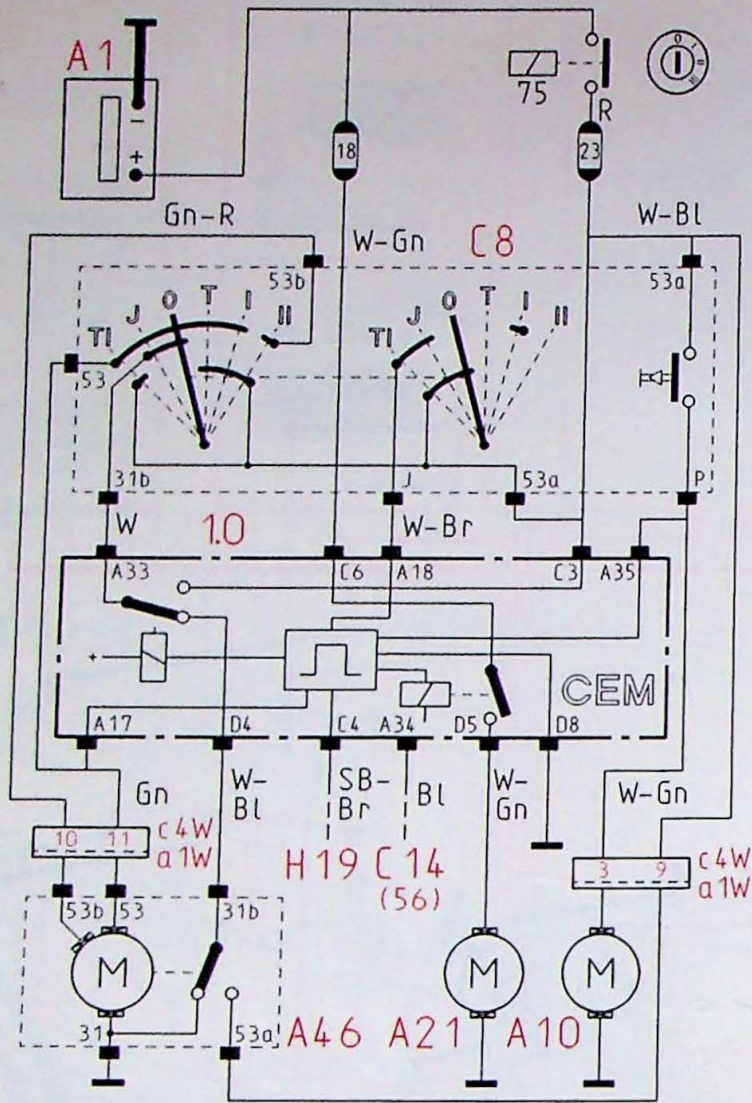

- 1.0 CEM
- A10 Ruitesproeierpomp
- A21 Koplampsproeierpomp
- A46 Ruitwissermotor
- C8 Ruitwisser-/wasschakelaar
- C14 Lichtschakelaar
- H19 Schakelaar volgas

Stand snelheid 1

Retourslag

Intervalstand

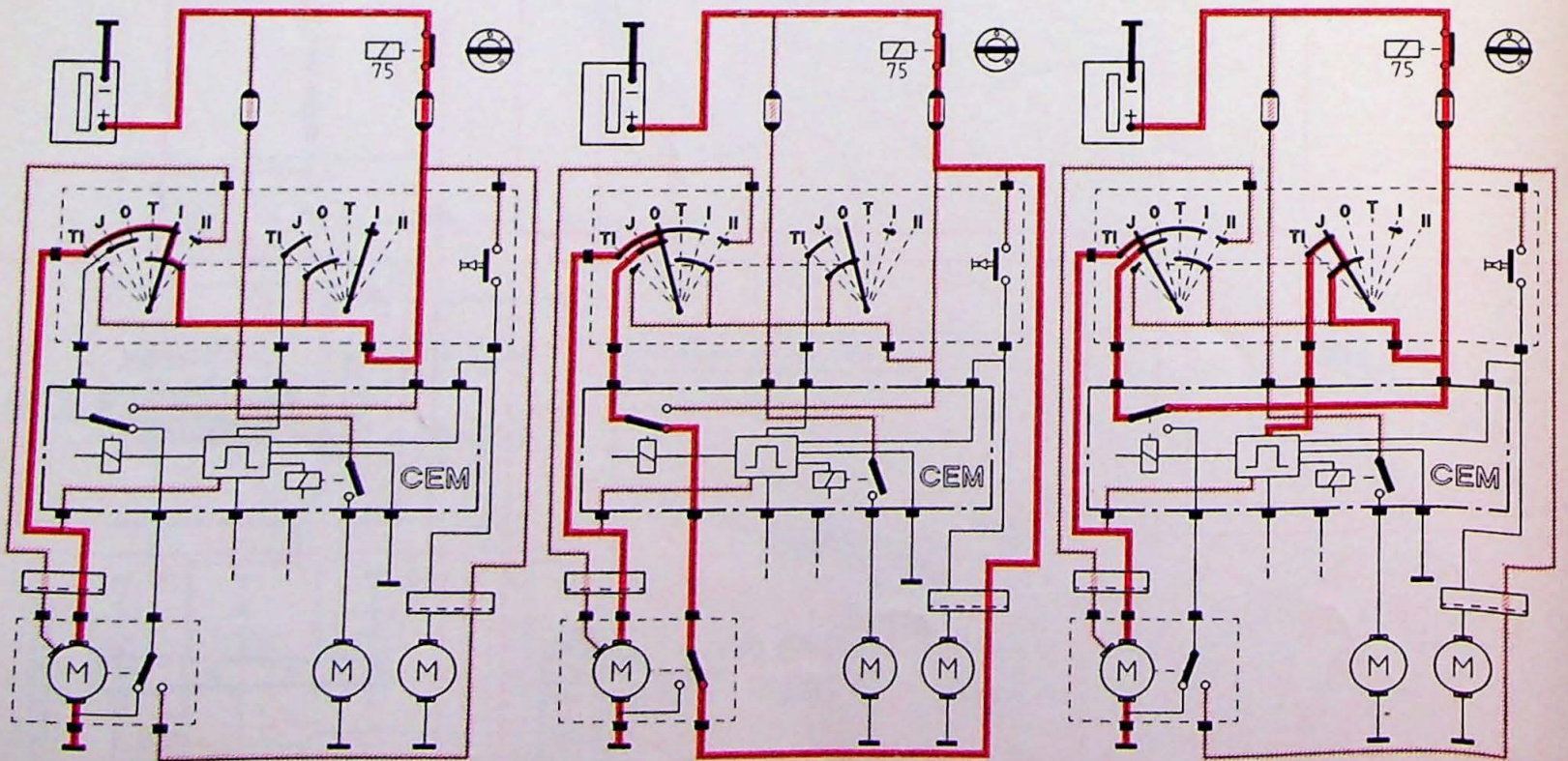

8-013/049A

# Ruitewissers, voorruit

**A46**

1 = Br  
2 = Gn  
3 = W-Bl  
4 = Gn-R  
5 = Gn

**C8**

1 (53b) = Gn-R  
2 (53) = Gn  
3 (53a) = W-Bl  
4 (P) = Gn-W  
5 (J) = Br-W  
6 (31b) = W

**C4W**

c4W ↔ a1W

3 = W-Gn  
9 = W-Bl  
10 = Gn-R  
11 = Gn

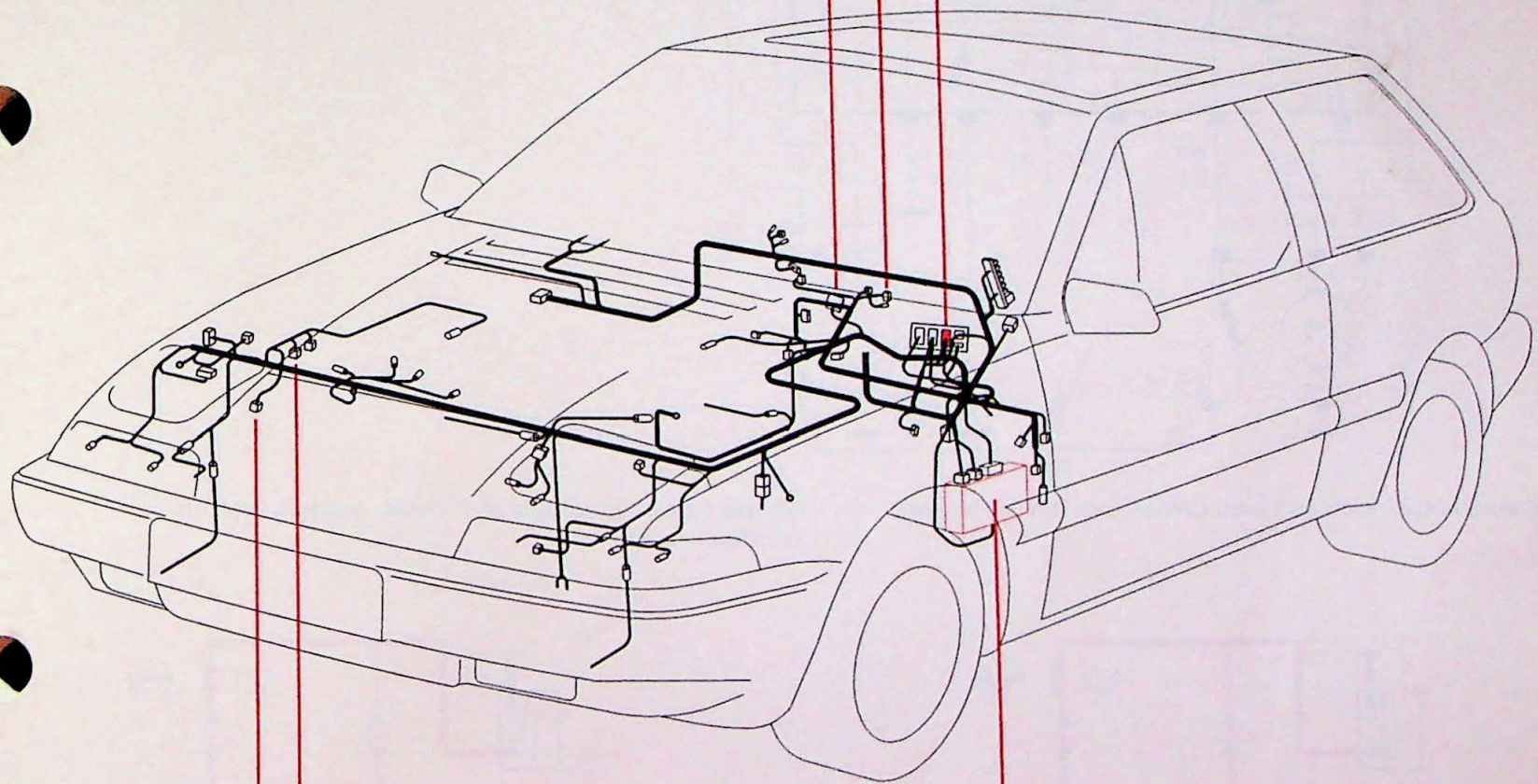

**A21**

W-Gn  
Br

**A10**

W-Gn  
Br

**1.0**

A

B C D

1 2 3 4 5 6 8

A17 = Gn  
A18 = W-Br  
A33 = W  
A34 = Bl  
A35 = W-Gn  
C3 = W-Bl  
C4 = SB-Br  
C6 = W-Gn  
D4 = W-Bl  
D5 = W-Gn  
D8 = Br

# Koplamp- en ruitesproeiers

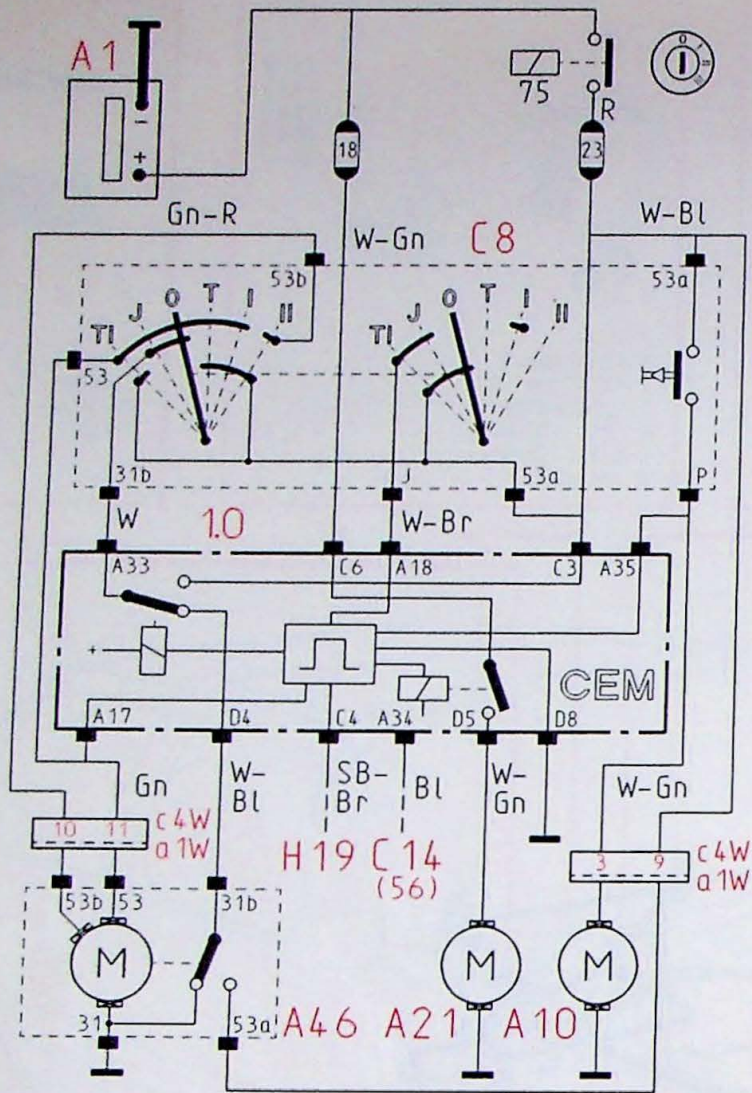

- 1.0 CEM
- A10 Ruitesproeierpomp
- A21 Koplampsproeierpomp
- A46 Ruitewissermotor
- C8 Ruitewisser-/wasschakelaar
- C14 Lichtschakelaar
- H19 Schakelaar volgas

Licht aan, koplampen sproeien (alleen dim- en grootlicht)

Volgas tijdens intermitterend wissen, wissers werken continu

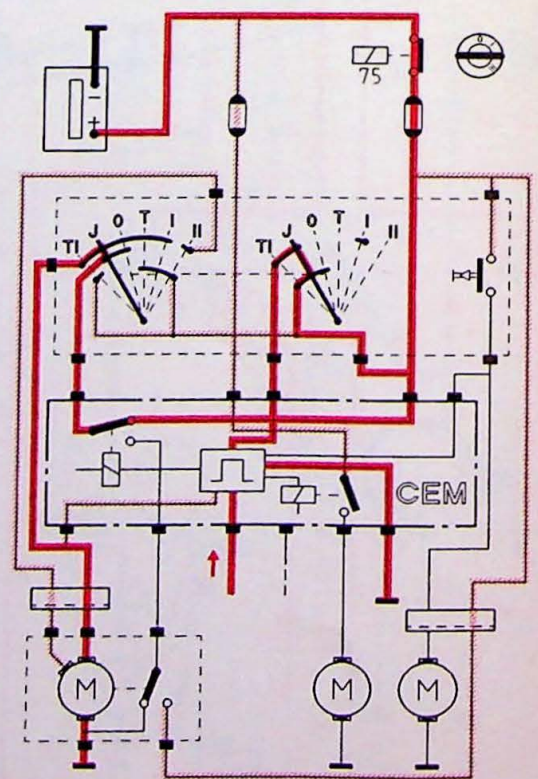
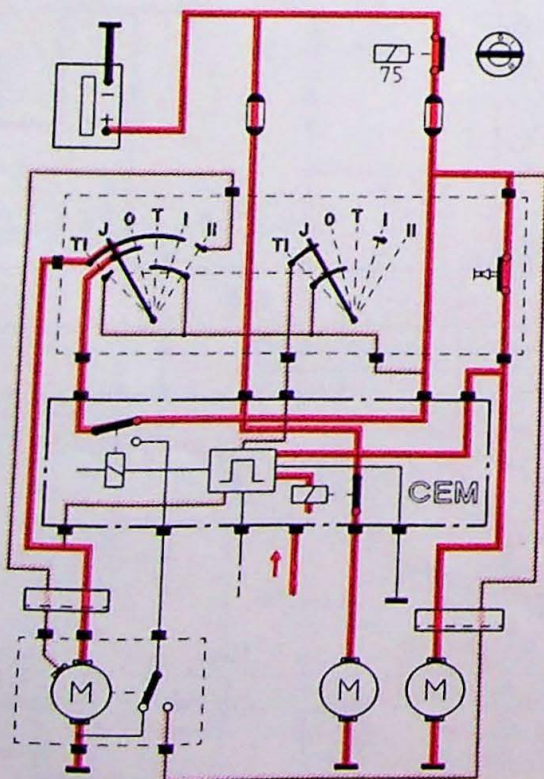

8-013/049B

# Koplamp- en ruitesproeiers

**A46**

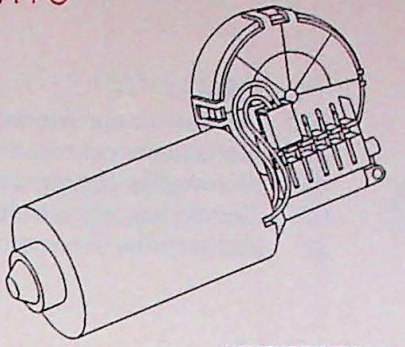

1 = Br  
2 = Gn  
3 = W-Bl  
4 = Gn-R  
5 = Gn



**C8**

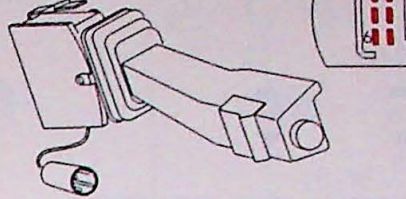

1 (53b) = Gn-R  
2 (53) = Gn  
3 (53a) = W-Bl  
4 (P) = Gn-W  
5 (J) = Br-W  
6 (31b) = W

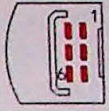

**C4W**

c4W ↔ a1W

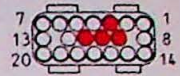

3 = W-Gn  
9 = W-Bl  
10 = Gn-R  
11 = Gn

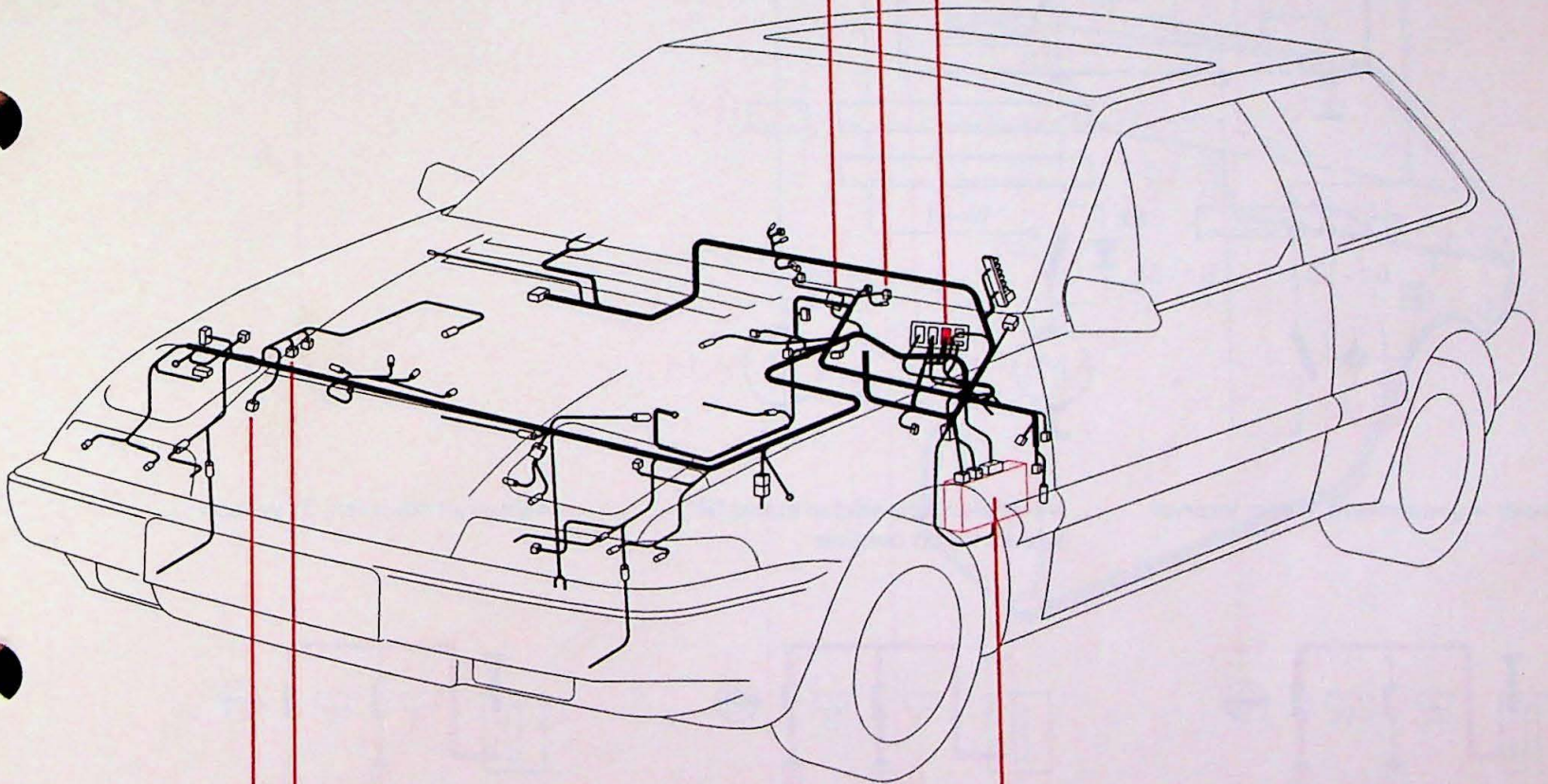

**A21**

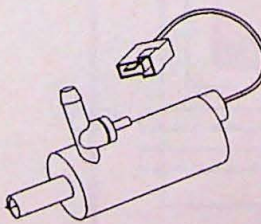

W-Gn  
Br

**A10**

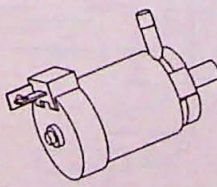

W-Gn  
Br

**1.0**

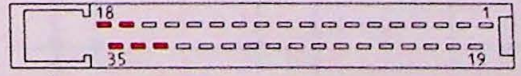

A

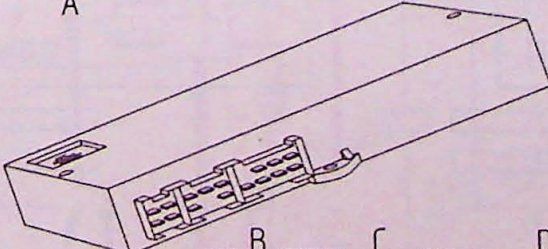

B C D

A17 = Gn  
A18 = W-Br  
A33 = W  
A34 = Bl  
A35 = W-Gn  
C3 = W-Bl  
C4 = SB-Br  
C6 = W-Gn  
D4 = W-Bl  
D5 = W-Gn  
D8 = Br

# Ruitwisser en sproeier, achterruit

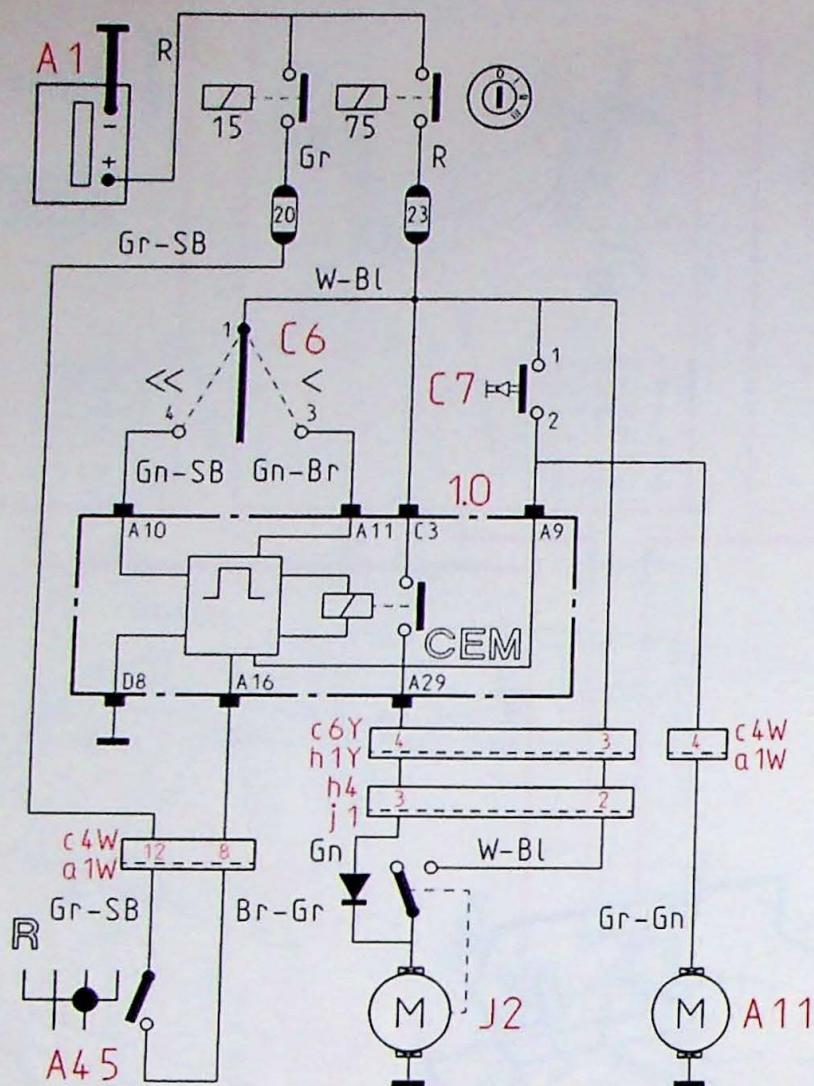

- 1.0 CEM
- A11 Achterruit-sproeierpomp
- A45 Schakelaar achteruitrijlichten
- C6 Schakelaar achterruitwisser
- C7 Schakelaar achterruitsproeier
- J2 Achterruitwissermotor

Wisser ingeschakeld, 6 sec. interval

Versnellingshendel in stand "R",  
wisser werkt continu

Achterruit sproeien, 3x wissen

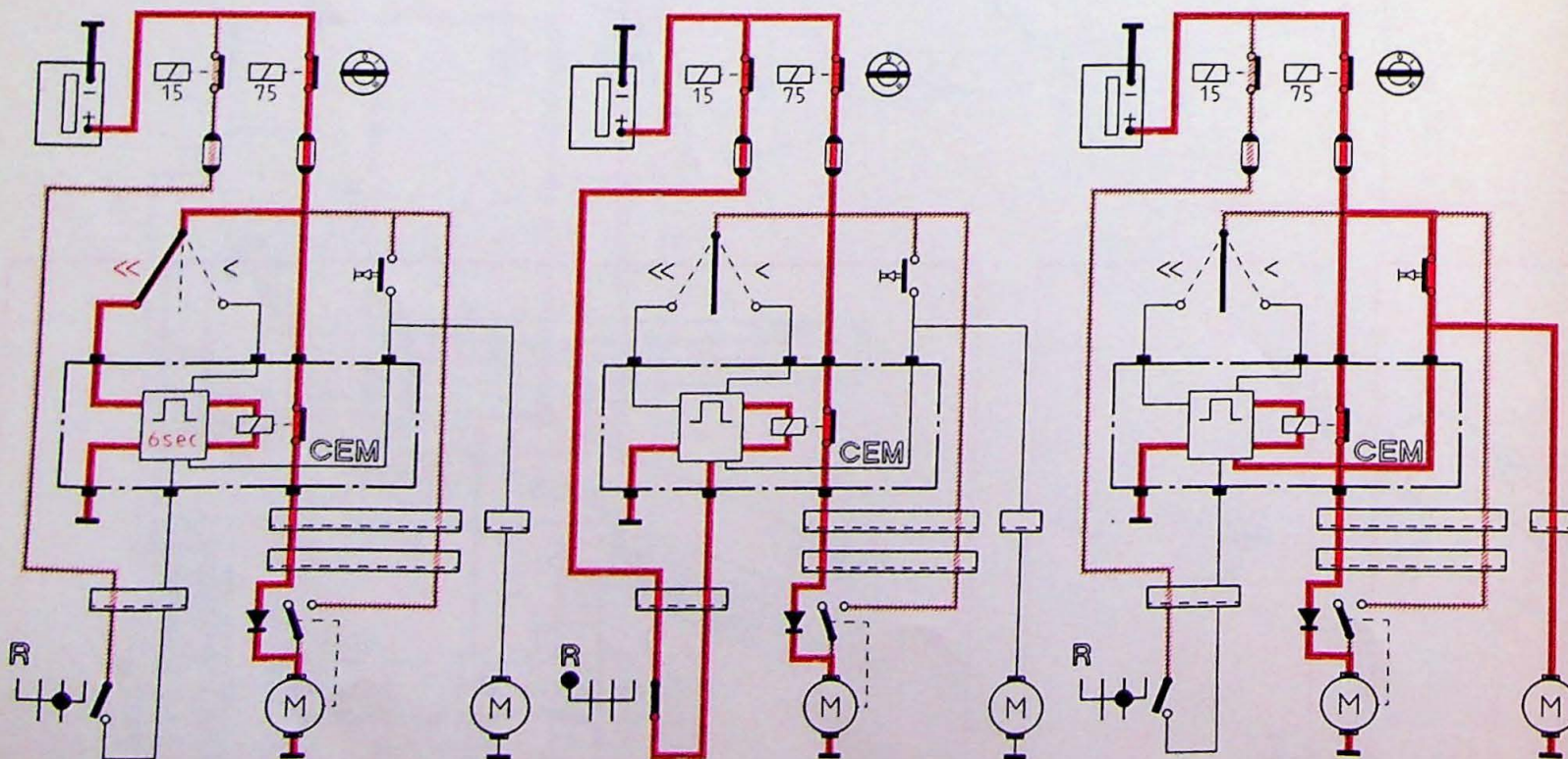

8-013/012

# Ruitewisser en sproeier, achterrait

**A11**

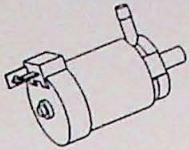

1 = Gr-Gn  
2 = Br

**c6Y**

c6Y ↔ h1Y

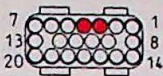

3 = W-Bl  
4 = Gn

**c4W**

c4W ↔ a1W

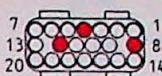

4 = Gr-Gn  
8 = Br-Gr  
12 = Gr-SB

**h4**

h4 ↔ j1



2 = W-Bl  
3 = Gn  
1 = Br

**J2**

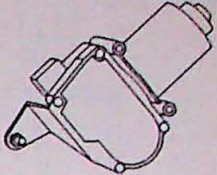

Gn  
W-Bl  
Br

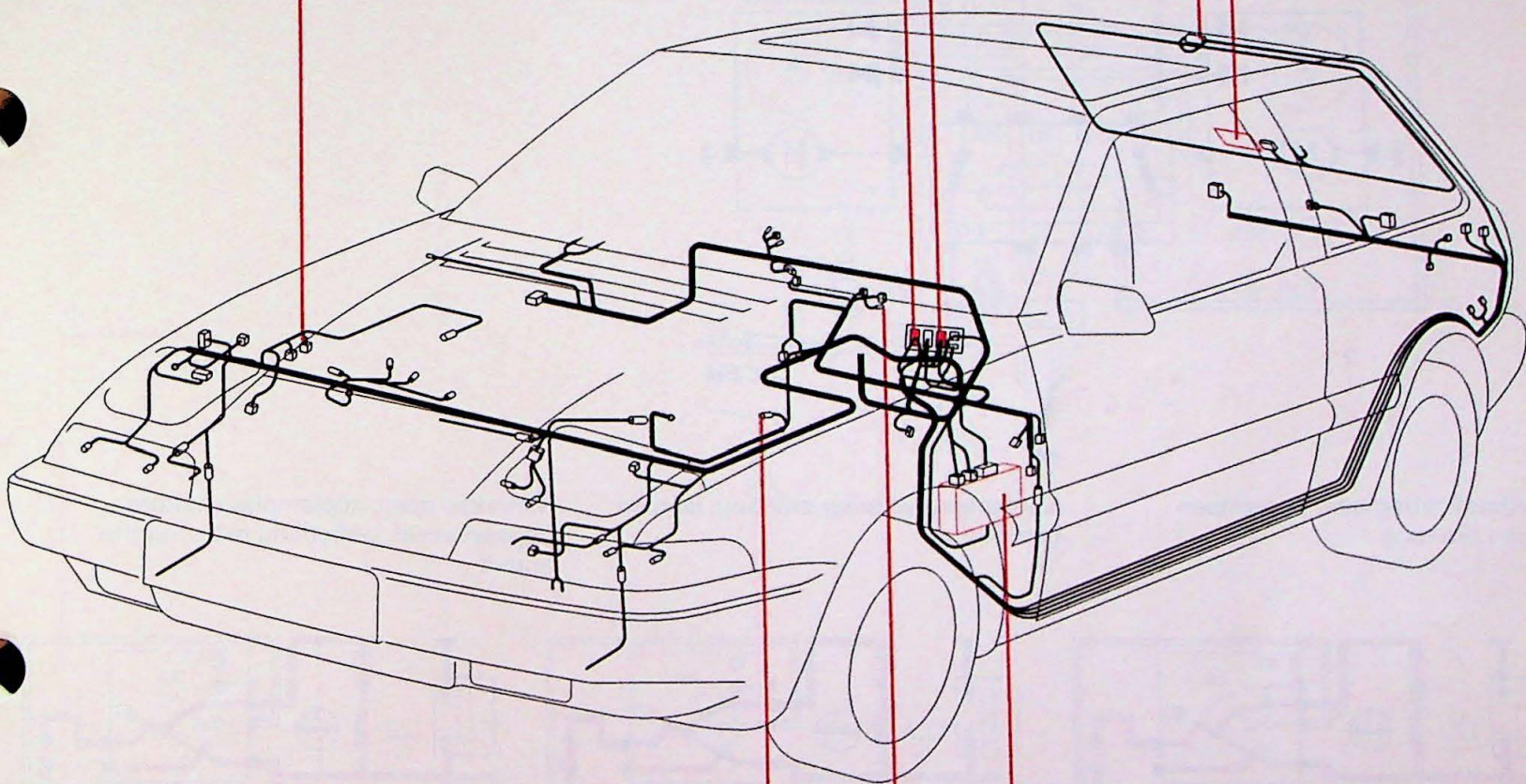

**A45**

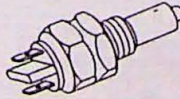

Gr-SB  
Br-Gr

**C6-C7**

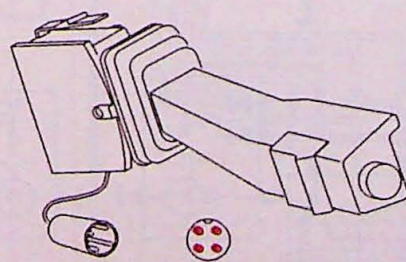

1 = W-Bl  
2 = Gr-Gn  
3 = Gn-Br  
4 = Gn-SB

**1.0**

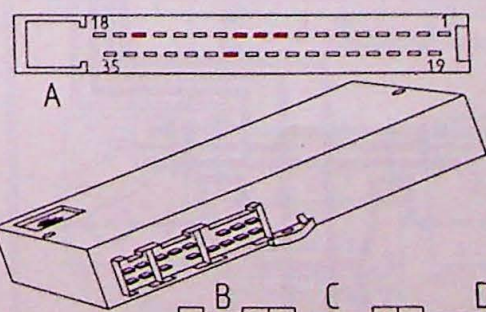

A9 = Gr-Gn  
A10 = Gn-SB  
A11 = Gn-Br  
A16 = Br-Gr  
A29 = Gn

C3 = W-Bl    D8 = Br

# Koplampuismotoren

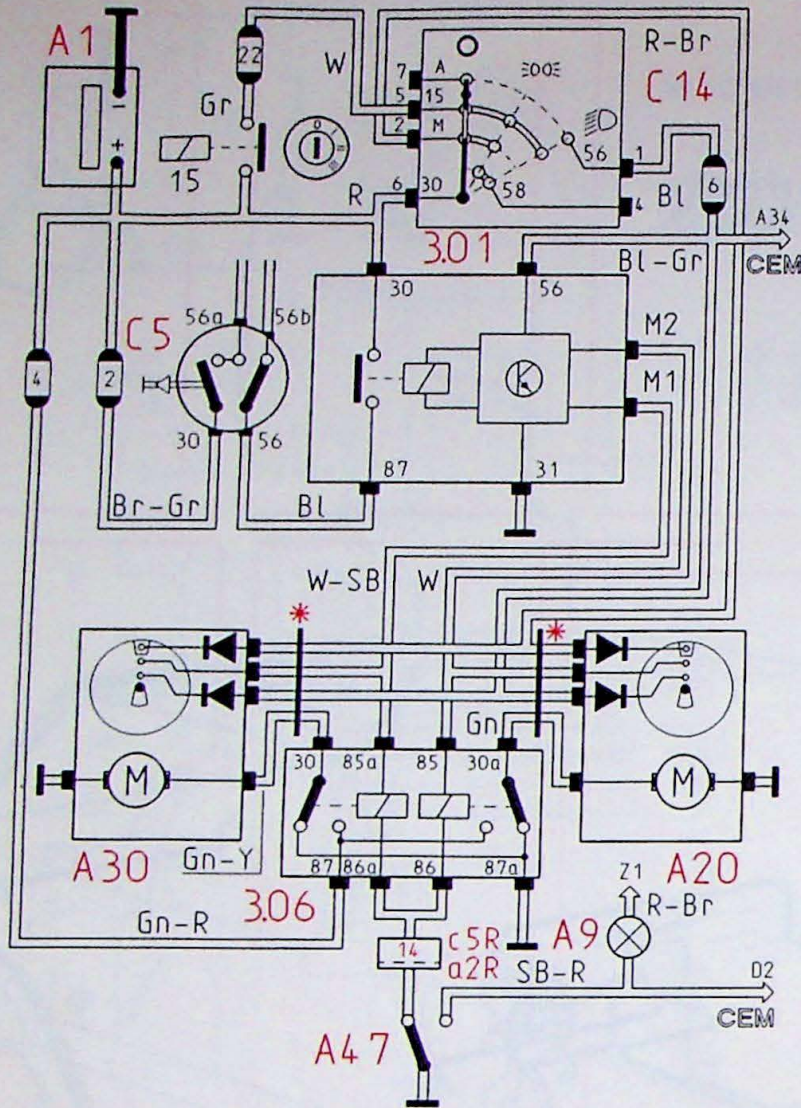

- 3.01 Koplampvoeding-sperrelais
- 3.06 Dubbelwerkend relais, koplampmotoren
- A9 Motorruimteverlichting
- A20 Motor, rechter koplamphuis
- A30 Motor, linker koplamphuis
- A47 Schakelaar, motorkapslot
- C5 Grootlicht-/dimlichtschakelaar
- C14 Lichtschakelaar

\* Zie rechter pagina

Hoofdverlichting aan, koplampen draaien omhoog

Koplampen volledig omhoog, lampen branden

Motorkap open, koplampuismotoren uitgeschakeld, verlichting motorruimte brandt

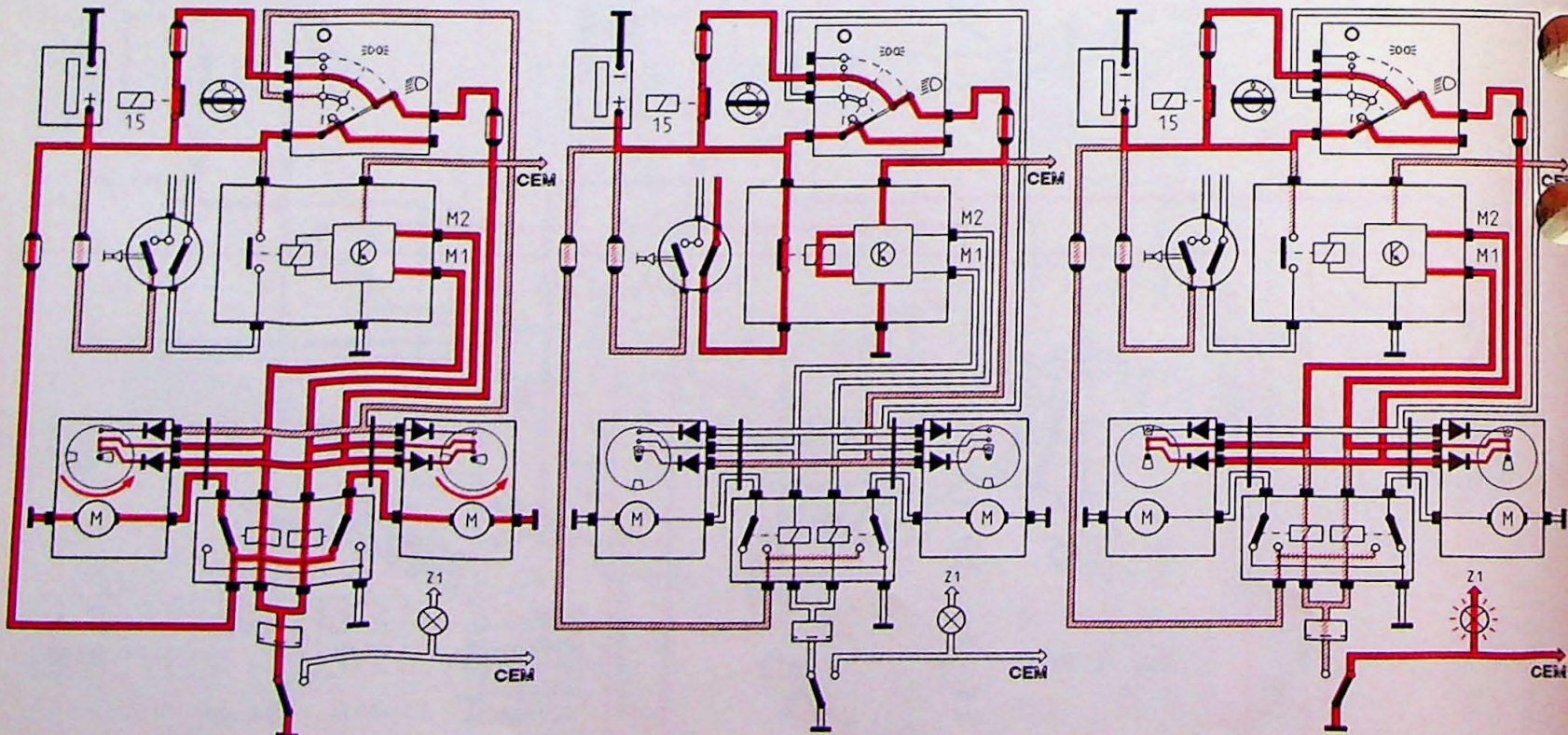

8-013/038

# Koplampuismotoren

c5R

c5R ↔ a2R

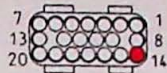

<L>  
A30

<R>  
A20

8 = Gn-Y    10 = Bl-Gr  
10 = Bl-Gr    15 = Gn  
13 = W-SB    16 = W  
20 = R-Br    20 = R-Br

C5

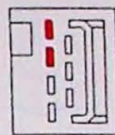
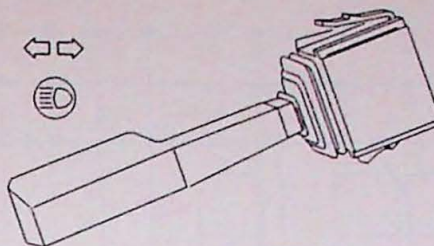

30 = Br-Gr  
56 = Bl

C14

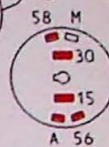
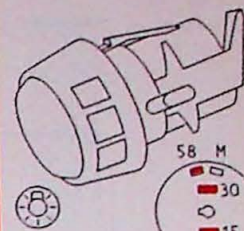

A = W  
15 = W  
30 = R  
56 = Bl  
58 = SB

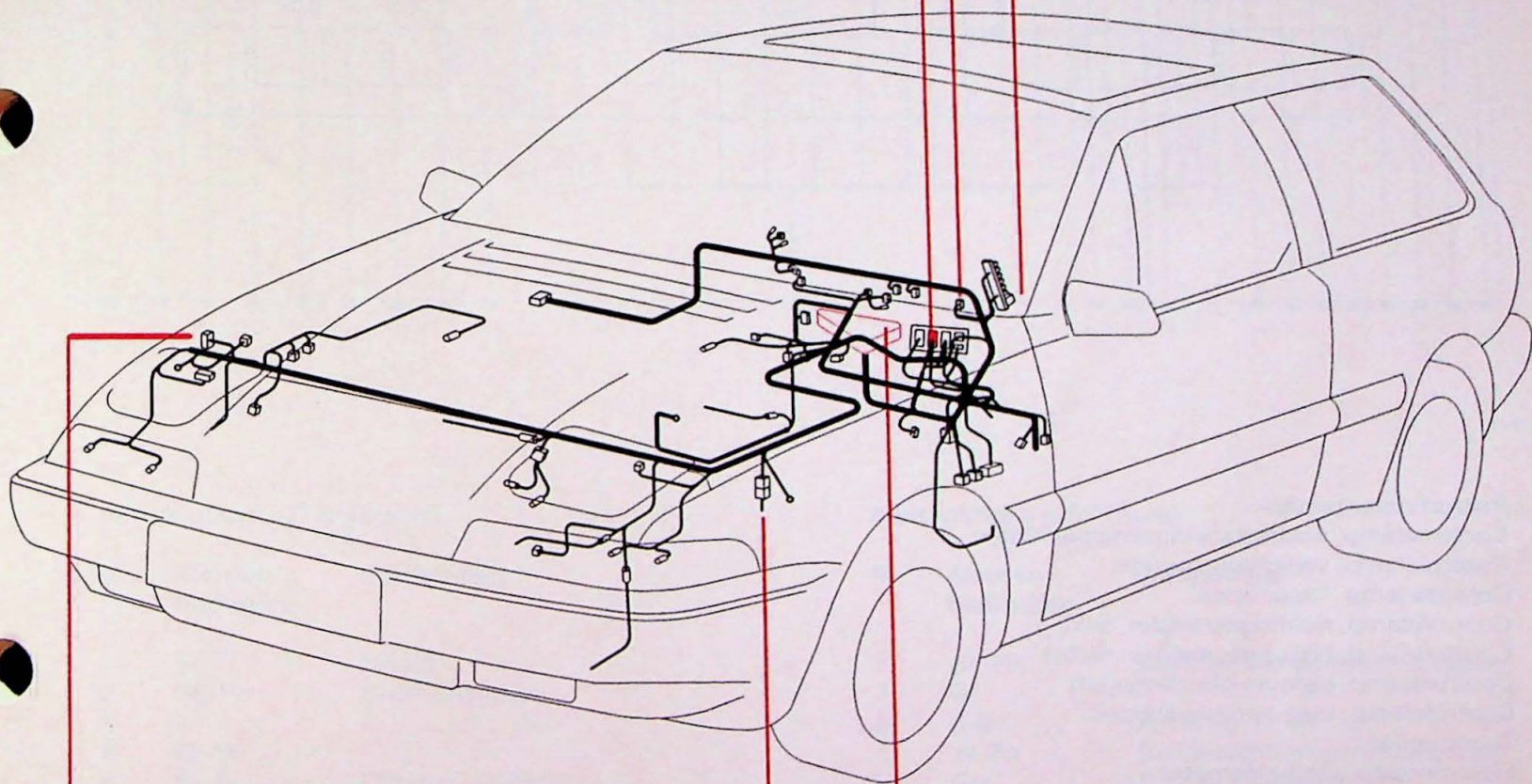

A20-A30

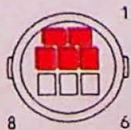
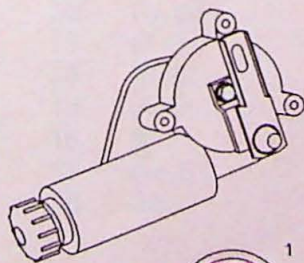

1 = Gn-Y  
2 = Br  
3 = Bl  
4 = Br-R  
5 = SB-W/W

3.0

3.01

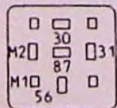
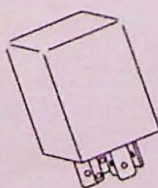

3.13 \*

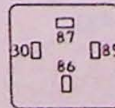
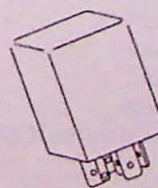
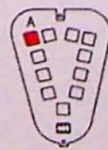

3.06

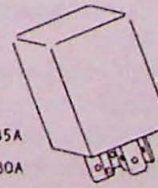
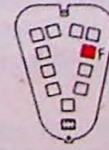

# Instrument, achterzijde

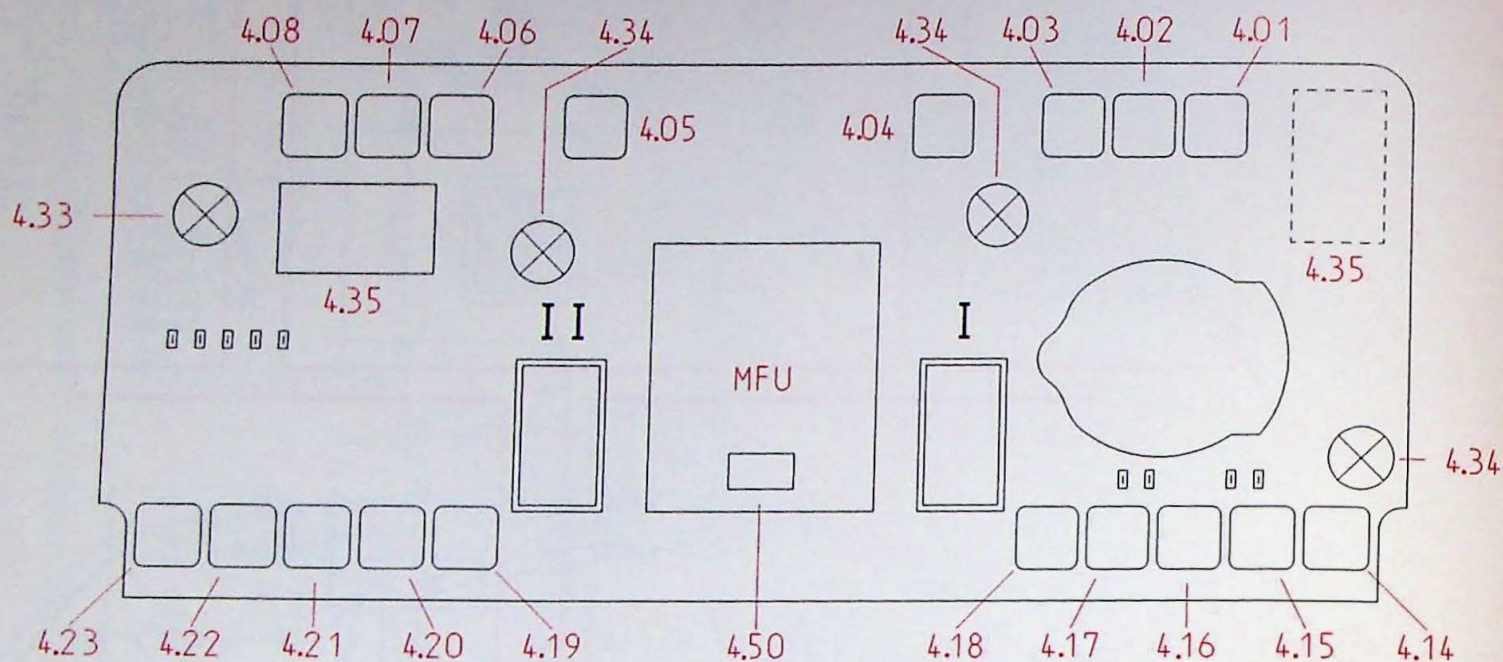

8-013/081

- 4.0 Instrumentenpaneel
- 4.01 Controlelamp, waarschuwingsknipperlichten
- 4.02 Controlelamp, veiligheidsgordels
- 4.03 Controlelamp, "deur open"
- 4.04 Controlelamp, richtingaanwijzer, links
- 4.05 Controlelamp, richtingaanwijzer, rechts
- 4.06 Controlelamp, defecte gloeilamp(en)
- 4.07 Controlelamp, laag-sproeiwaterpeil
- 4.09 Toerenteller
- 4.11 Elektronische snelheidsmeter
- 4.14 Controlelamp, parkeerlicht
- 4.15 Controlelamp, mistlampen
- 4.16 Controlelamp, mistachterlicht
- 4.17 Controlelamp, verwarmde achterraut
- 4.18 Controlelamp, grootlicht/lichtsignaal
- 4.19 Waarschuwinglamp, ABS-systeem
- 4.20 Controlelamp, handrem
- 4.21 Controlelamp, remvloeistof
- 4.22 Controlelamp, laadstroom
- 4.23 Controlelamp, oliedruk
- 4.31 MFU
- 4.33 LCD verlichting
- 4.34 Verlichting, instrumentenpaneel
- 4.35 15/30 Voedingsrelais, instrumentenverlichting
- 4.50 Kanaalschakelaar

# Instrument met informatiecentrum, BI + Y

1 = c21Bl  
2 = c20Y

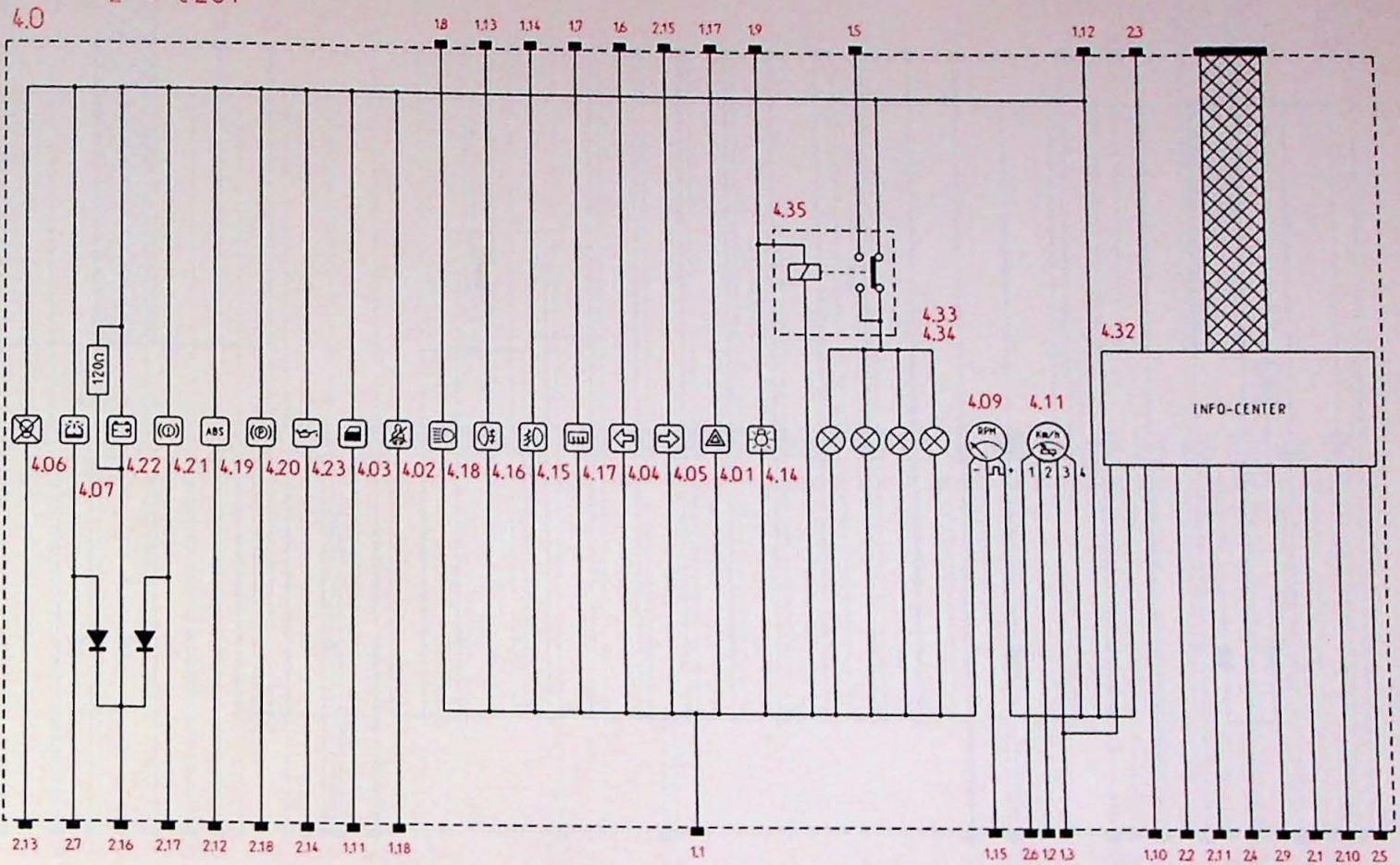

8-013/073

## Aansluitingen c21 BI (Blauw)

Nr	Kleuren bedrading	Component
1	Br	Massa
2	SB-Br	Snelheidsgever
3	-	-
4	Gr-W	-
5	Br-Gr	Dimmer verlichting
6	Gn-R	Richtingaanwijzer links
7	Y-W	CEM (B3) achterrautverwarming
8	Y-R	Zekering 9 grootlicht
9	Br-BI	Zekering 10 dimlicht
10	Y	Olie-niveaugever
11	Y-SB	CEM (A21) deur open
12	Gr-W	Zekering 19
13	BI-Gr	Mistlamp achter
14	Br-Gr	Relais mistlampen
15	Br-BI	Elektronische ontsteking
16	BI	-
17	Gn-SB	Waarschuwingslichten
18	SB	CEM (A6) veiligheidsgordel

## Aansluitingen c20Y (Geel)

Nr	Kleuren bedrading	Component
1	Gr-SB	Koelvloeistof temperatuurgever
2	Gr	-
3	R-Br	Zekering 1
4	W-Bn	Buitenlucht temperatuurgever
5	Gn	B1 (26) injectiesignaal
6	Y-Br	Massa (snelheidsgever)
7	Gn-Br	Vlotter sproeivloeistof
8	-	Cruise
9	W	Motorolietemperatuurgever
10	Br-BI	-
11	Gn-SB	Vlotter tank
12	SB	ABS
13	BI	Defectgever gloeilampen
14	W-SB	Schakelaar oliedruk
15	Gn-Y	Richtingaanwijzer rechts
16	R-Br	Dynamo
17	BI	Vlotter remvloeistof
18	BI	Schakelaar handrem

# Instrument met informatiecentrum, R + Y

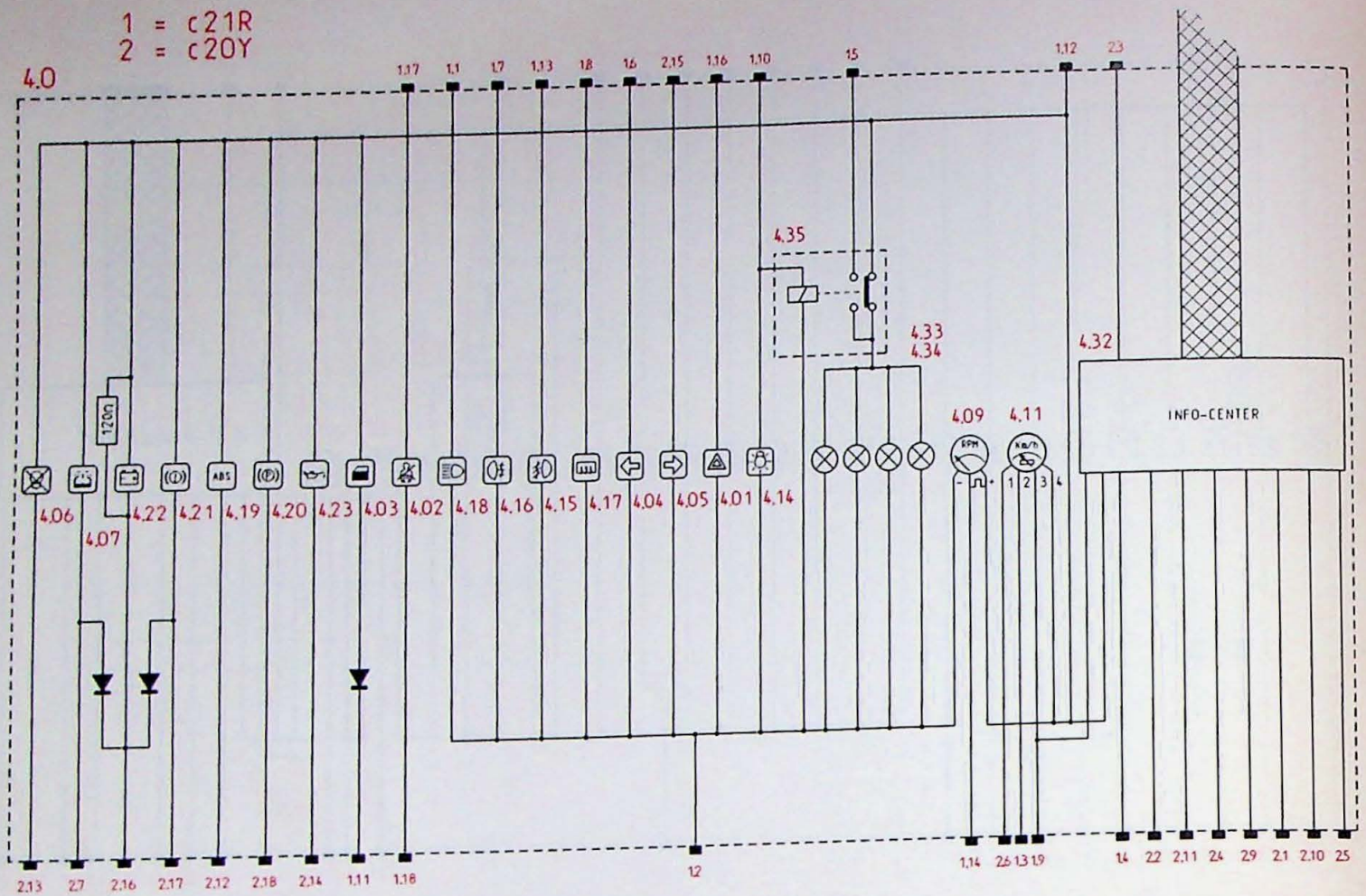

B-013/076

## Aansluitingen c21R (Rood)

Nr	Kleuren bedrading	Component
1	Bl-Gn	Grootlicht
2	Br	Massa
3	SB-Br	Snelheidsgever
4	Y	Olieniveaugever
5	Br-Gr	Dimmer verlichting
6	Gn-R	Richtingaanwijzer links
7	Bl-Gr	Mistlamp achter
8	Y-W	Achterrautverwarming
9	-	-
10	Br-Bl	Groot/dimlichtschakelaar
11	Y-SB	CEM (A21) deur open
12	Gr-W	Zekering 19
13	Br-Gr	Relais mistlampen
14	Br-Bl	Elektronische ontsteking
15	-	-
16	Gn-SB	Waarschuwinglichten
17	Gr-R	Veiligheidsgordel
18	SB	CEM (A6) veiligheidsgordel

## Aansluitingen c20Y (geel)

Nr	Kleuren bedrading	Component
1	Gr-SB	Koelvloeistoftemperatuurgever
2	Gr	Olieniveaugever
3	R-Br	Zekering 1
4	W-Bl	Buitenluchttemperatuurgever
5	Gn	B1 (26) injectiesignaal
6	Y-Br	Massa (snelheidsgever)
7	Gn-Br	Vlotter sproeivloeistof
8	-	-
9	W	Olietemperatuurgever
10	Br-Bl	Massa sensoren
11	Gn-SB	Vlotter tank
12	SB	ABS
13	Bl	Defectgever gloeilampen
14	W-SB	Oliedrukgever
15	Gn-Y	Richtingaanwijzer rechts
16	R-Br	Dynamo
17	Bl	Vlotter remvloeistof
18	Gr	Schakelaar handrem

# Instrument met informatiecentrum, Gn + Gr

1 = c21Gn  
2 = c20Gr

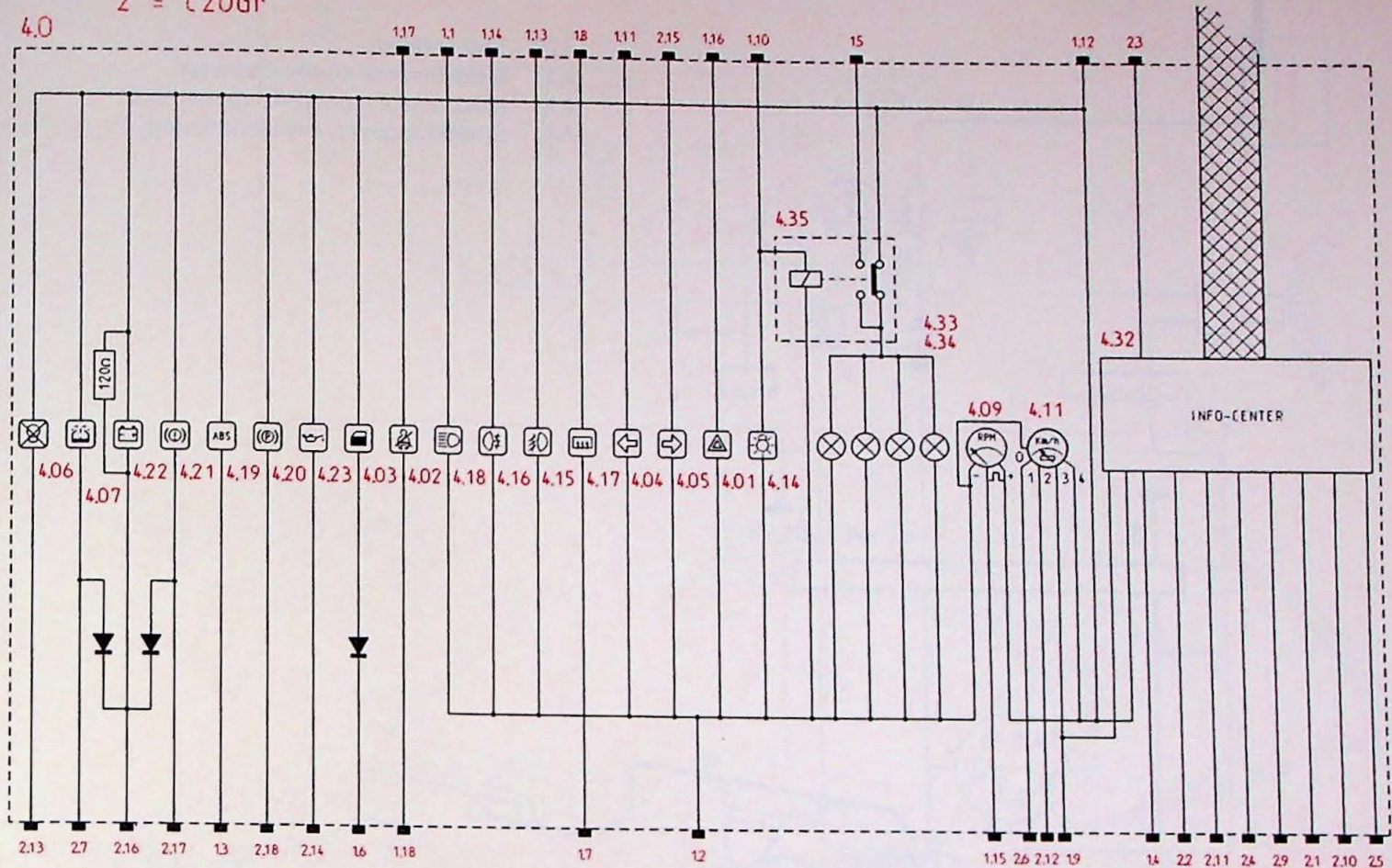

8-013/077

## Aansluitingen c21 Gn (Groen)

Nr	Kleuren bedrading	Component
1	Bl-Gn	Grootlicht
2	Br	Massa
3	SB	ABS
4	Y	Olieniveaugever
5	Br-Gr	Dimmer dashboard
6	Y-SB	CEM (A21) deur open
7	Y-W	Achterraiteverwarming
8	Br	Achterraiteverwarming
9	-	-
10	Br-BI	Dimmer verlichting
11	Gn-R	Richtingaanwijzer links
12	Gr-W	Zekering 19
13	Bl-Gr	Mistlamp achter
14	Br-Gr	Relais mistlampen
15	Br-BI	Toerentalsignaal ontsteking
16	Gn-SB	Waarschuwinglichten
17	Gr-R	Veiligheidsgordel
18	SB	CEM (A6) veiligheidsgordel

## Aansluitingen c20Gr (Grijs)

Nr	Kleuren bedrading	Component
1	Gr-SB	Watertemperatuurgever
2	Gr	Olieniveaugever
3	R-Br	Zekering 1
4	W-BI	Buitentemperatuurgever
5	Gn	B1 (26) injectiesignaal
6	SB-Br	Massa (snelheidsmeter)
7	Gn-Br	Vlotter sproeiwater
8	-	-
9	W	Olietemperatuurgever
10	Br-BI	Massa sensoren
11	Gn-SB	Vlotter tank
12	Y-Br	-
13	Bl	Defectgever gloeilampen
14	W-SB	oliedrukgever
15	Gn-Y	Richtingaanwijzer rechts
16	R-Br	Dynamo
17	Bl	Vlotter remvloeistof
18	Gr	Schakelaar handrem

# Toerenteller en snelheidsmeter

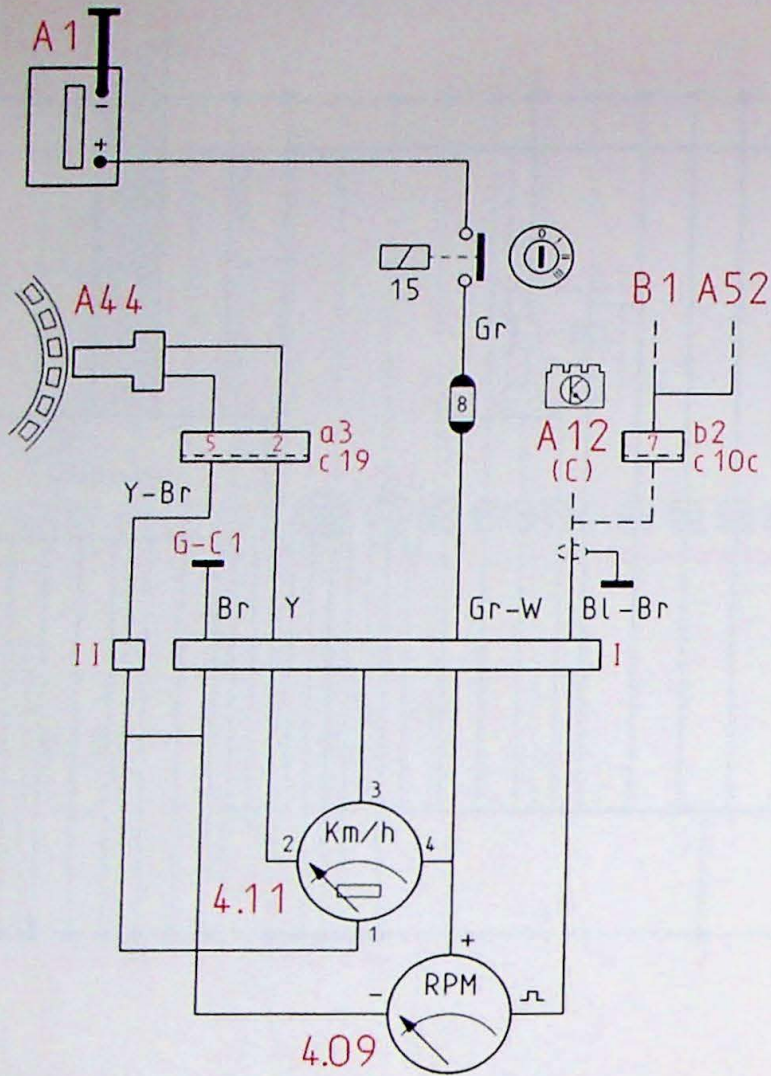

- 4.09 Toerenteller
- 4.11 Elektronische snelheidsmeter
- A12 Elektronische ontstekingseenheid
- A44 Snelheidsgever, eindaandrijving

Toerenteller

Snelheidsmeter

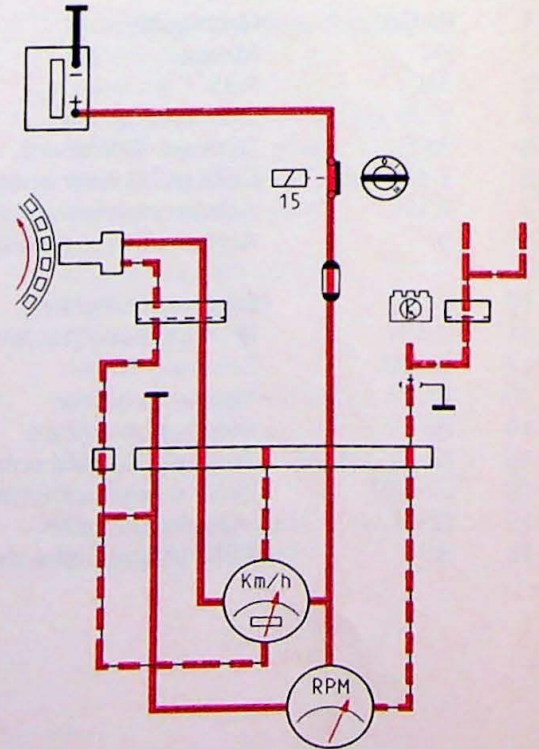
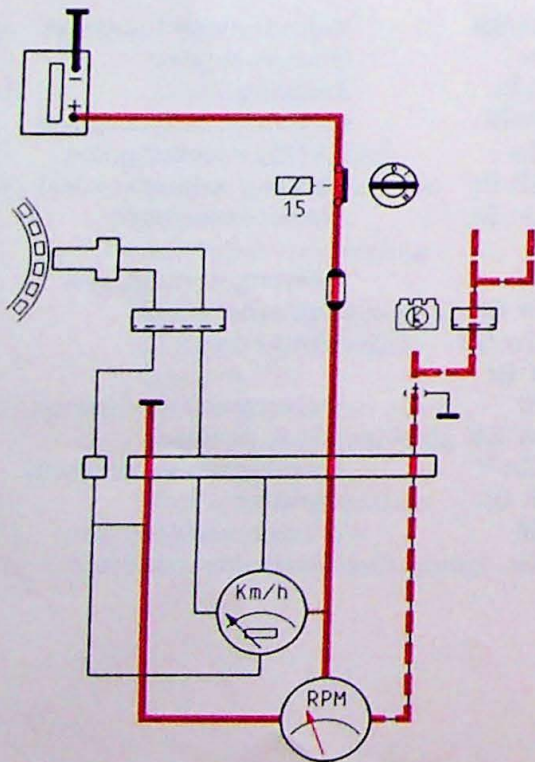

8-013/034

# Toerenteller en snelheidsmeter

4.0

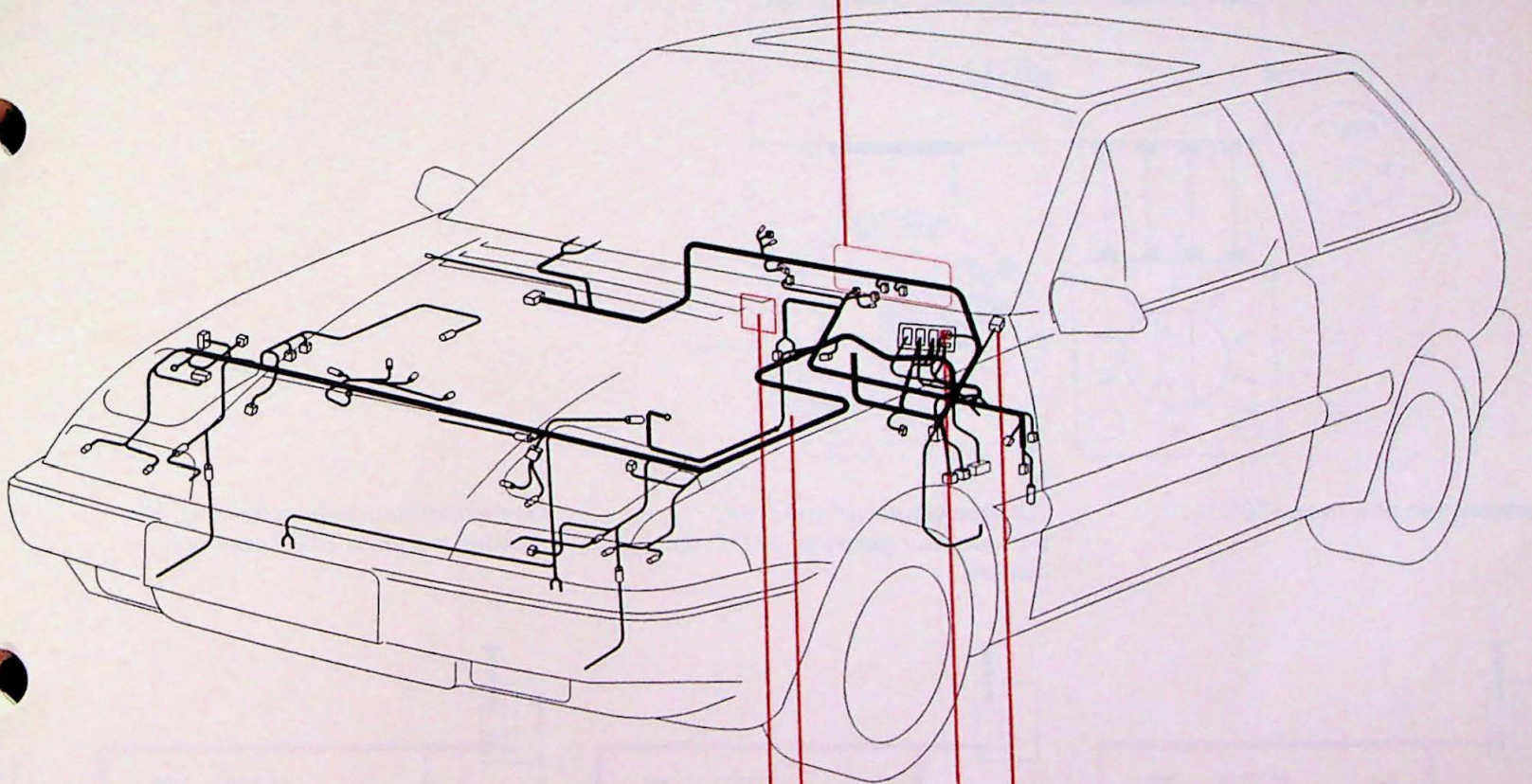
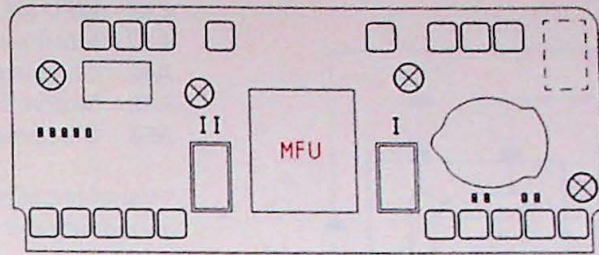

A12

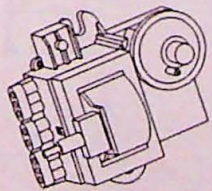

A44

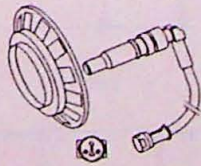

c 19

c 19 → a3

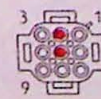

2 = SB-Br (Y)  
5 = Y-Br

G-C 1

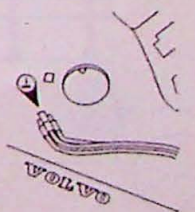

# Informatiecentrum, olieniveau, olietemperatuur

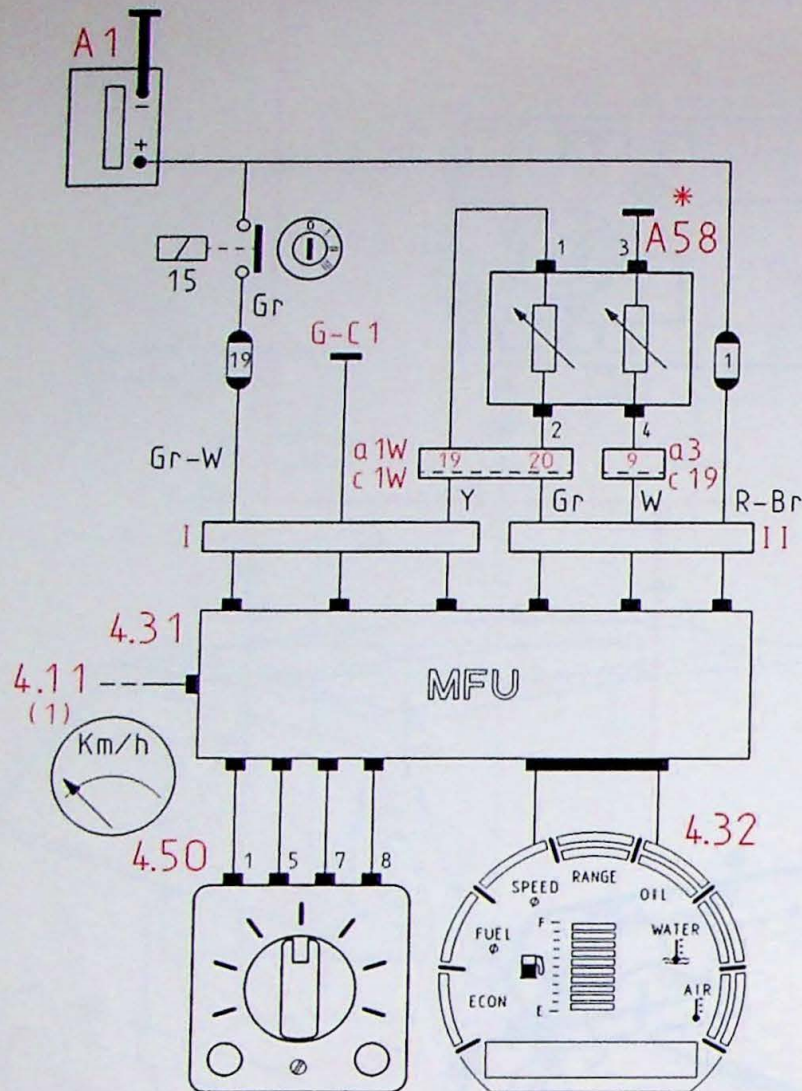

- 4.11 Elektronische snelheidsmeter
- 4.31 MFU (Multi-function-unit)
- 4.32 Informatiecentrum (LCD paneel)
- A40 Olieniveaugever
- A43 Motorolietemperatuurgever
- A58 Olieniveau en temperatuurgever

\* Vanaf chassisnummer 519640 A40 en A43 gecombineerd tot A58

Startcontrole olieniveau "OK"

"Olietemperatuur" gekozen, temperatuur getoond, 101°C op display

Olietemperatuur waarschuwing, alle standen mogelijk, STOP op display

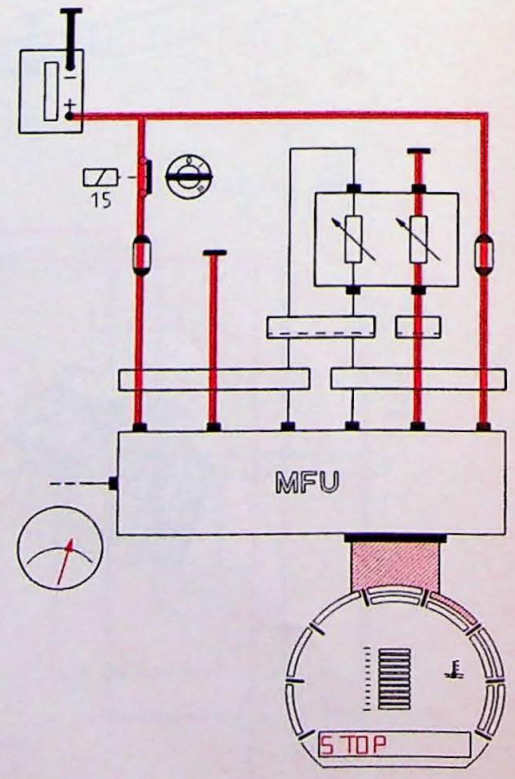
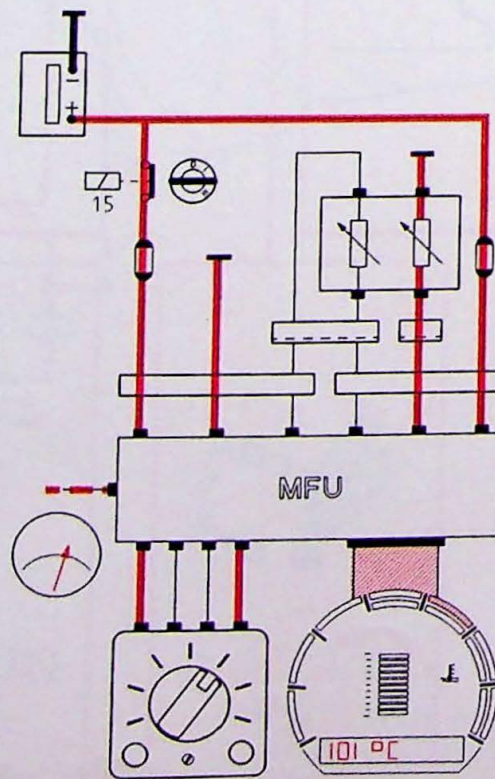
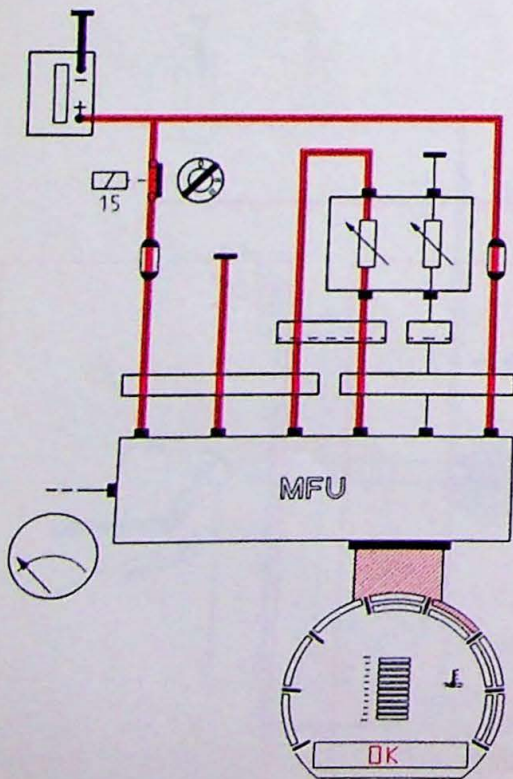

8-013/033

# Informatiecentrum, olieniveau, olietemperatuur

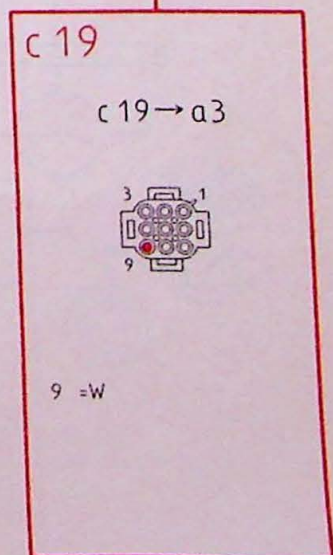
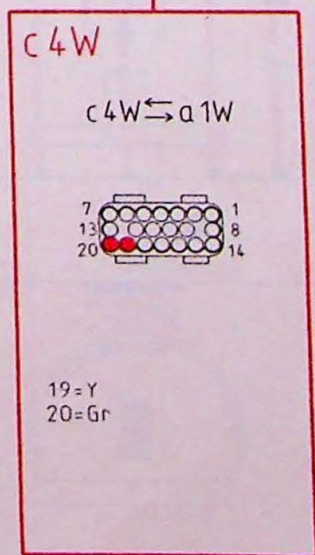
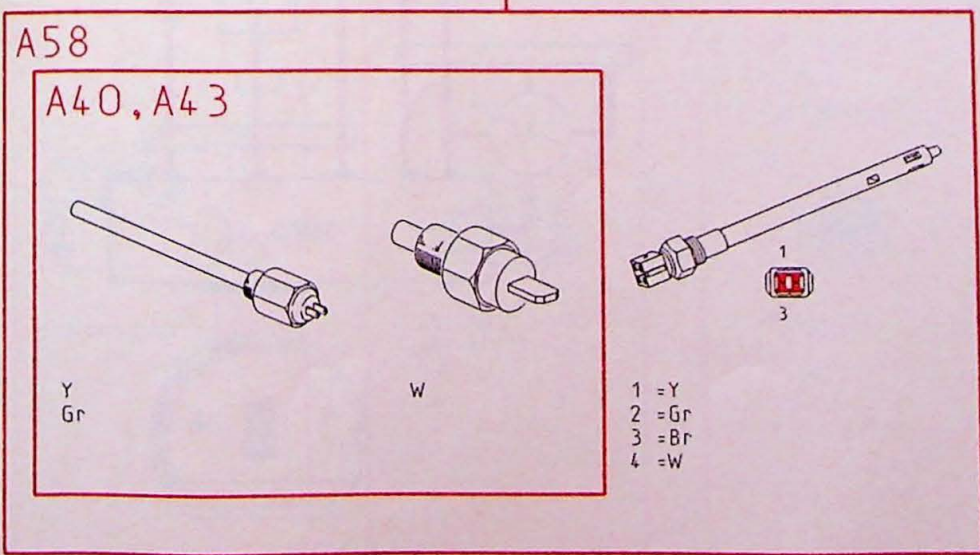
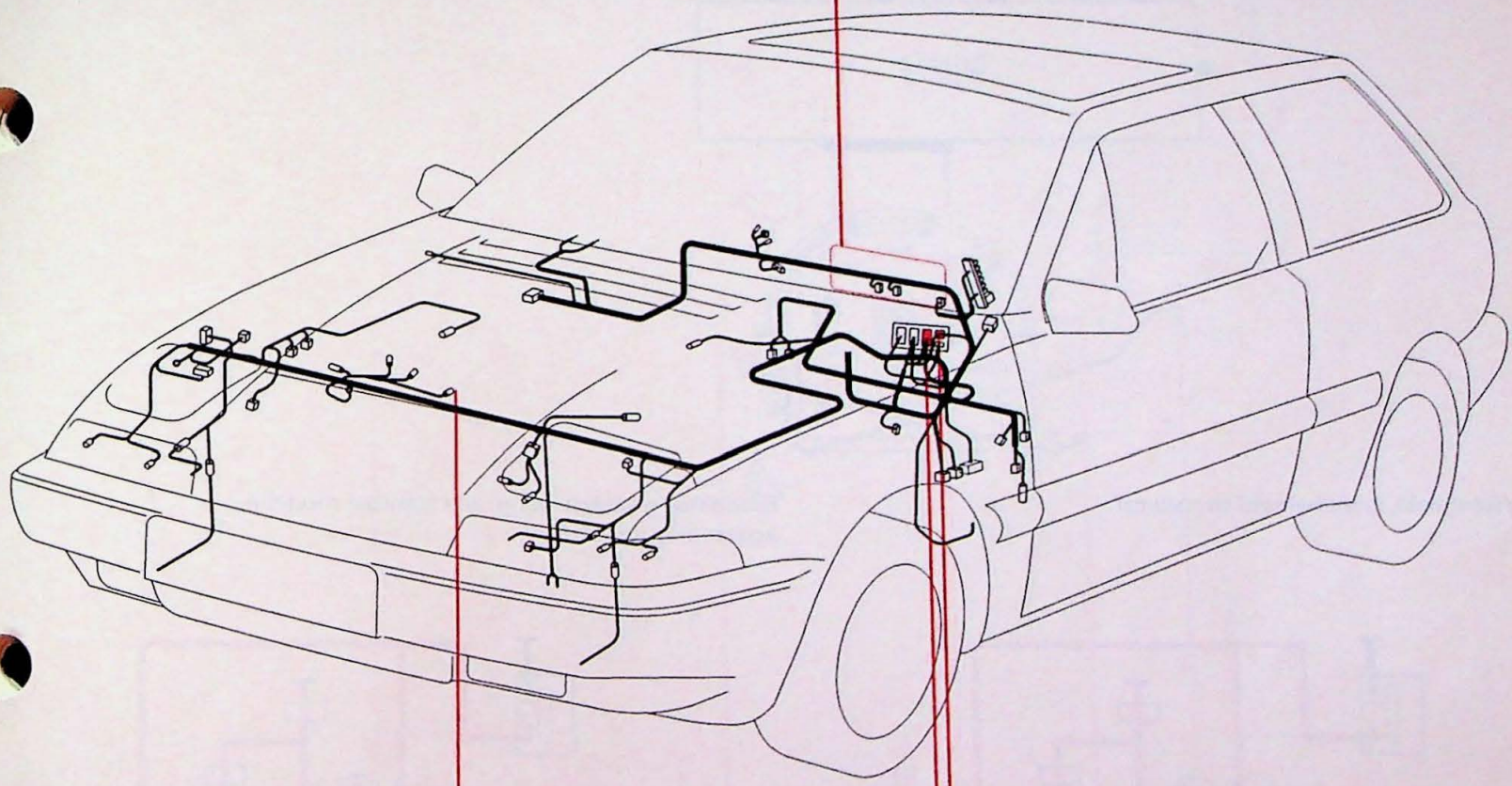
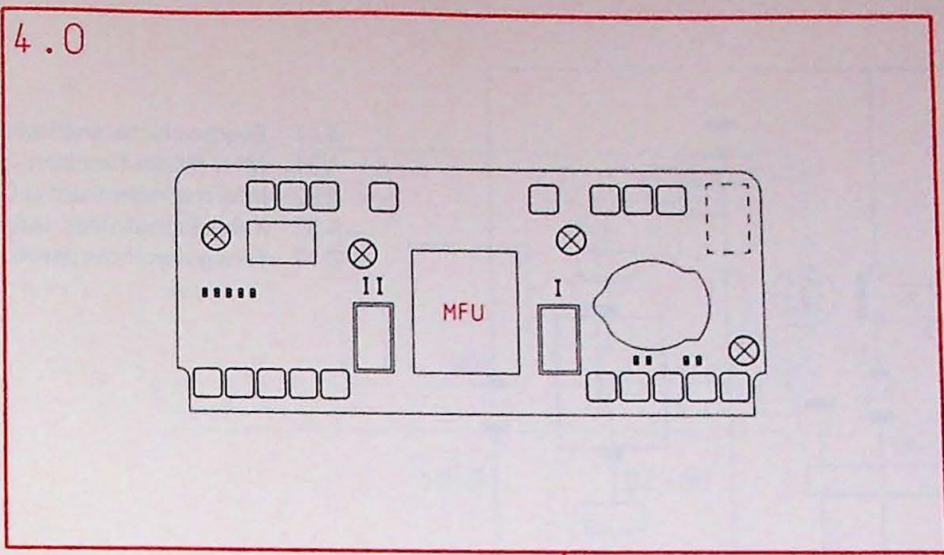

# Informatiecentrum, brandstofmeter

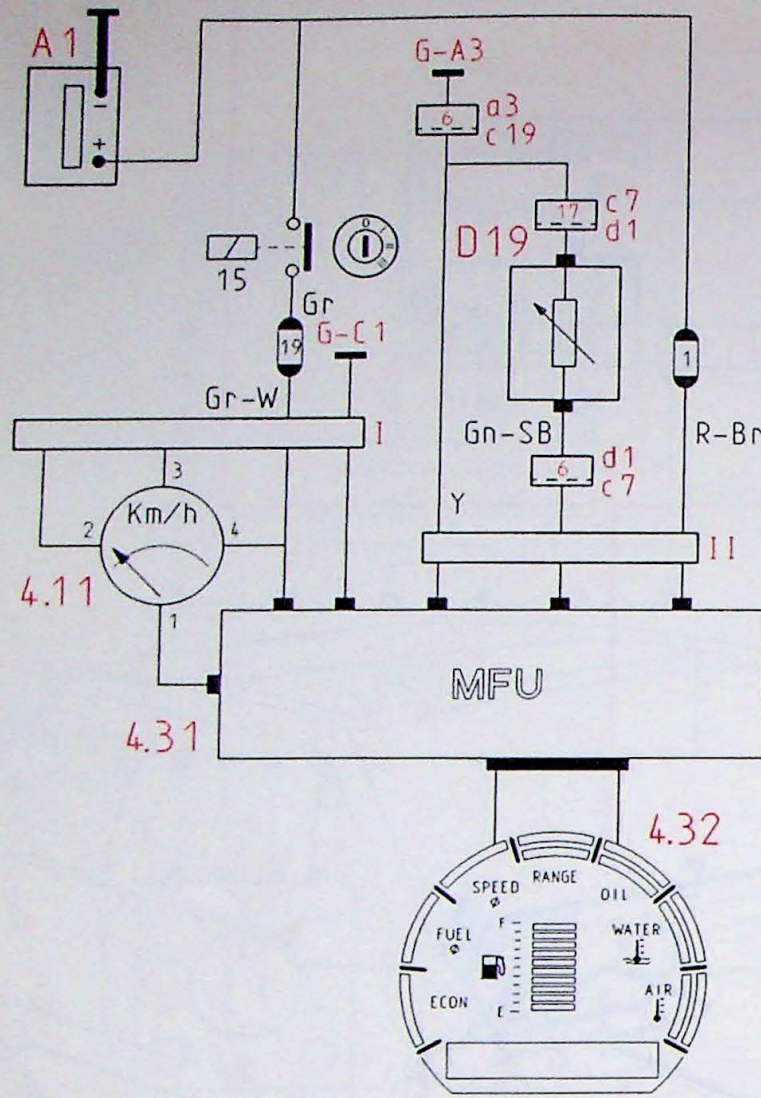

- 4.11 Elektronische snelheidsmeter
- 4.31 MFU (Multi-function-unit)
- 4.32 Informatiecentrum (LCD-paneel)
- 4.50 Kanaalschakelaar, informatiecentrum
- D19 Tankgever, brandstofmeter

Startcontrole, hoeveelheid brandstof

Brandstof waarschuwing, alle standen mogelijk, actieradius op display

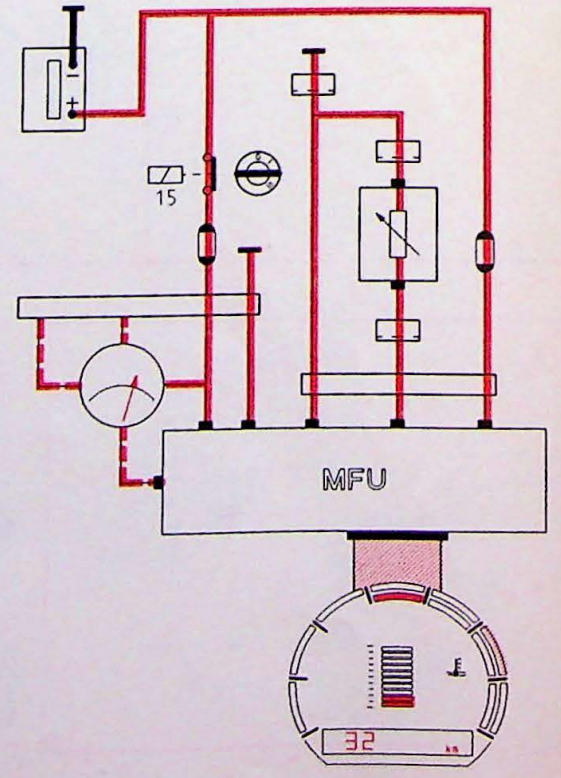
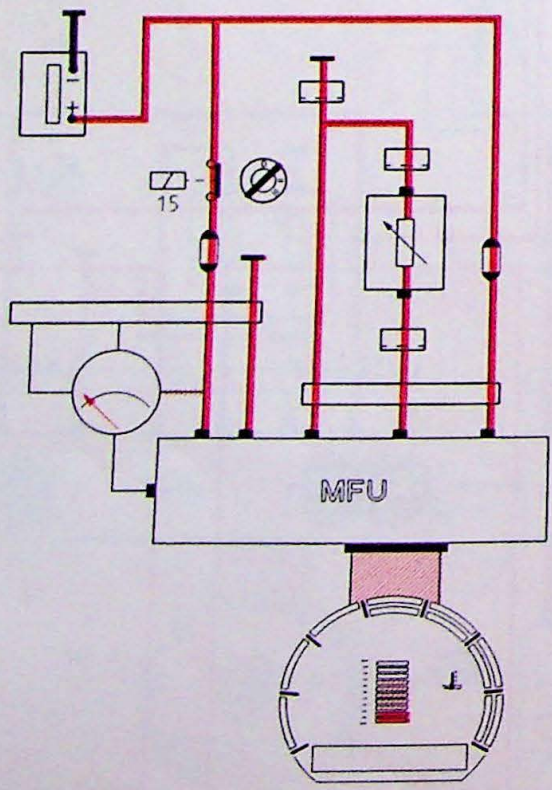

8-013/032

# Informatiecentrum, brandstofmeter

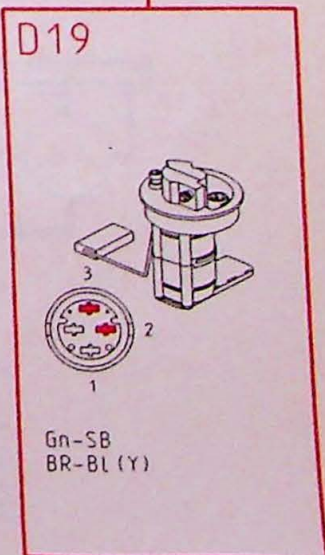
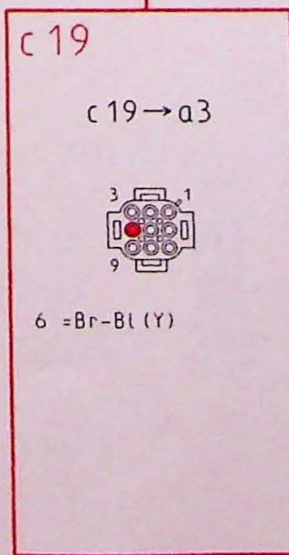
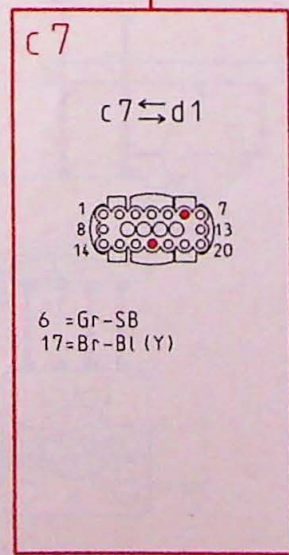
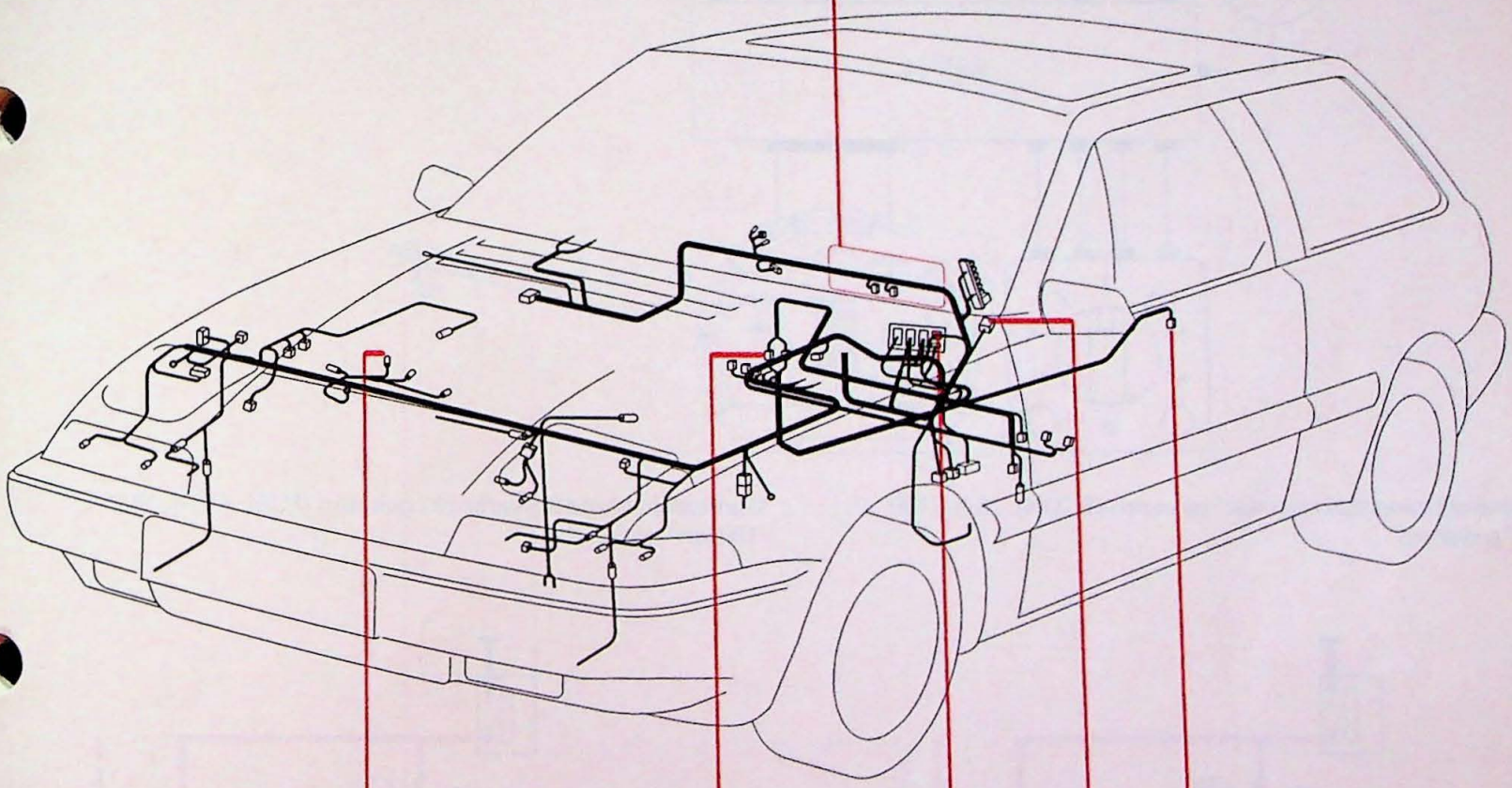
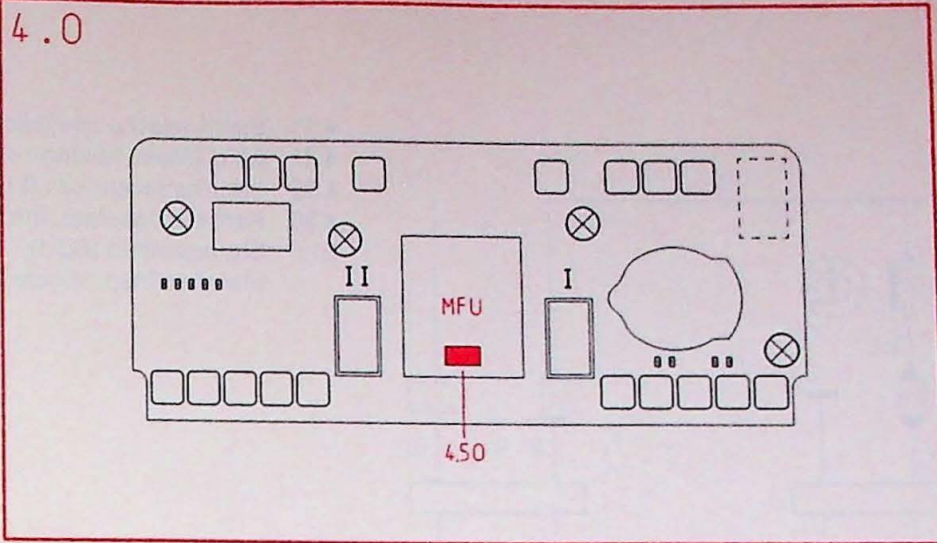

# Informatiecentrum, brandstofverbruik

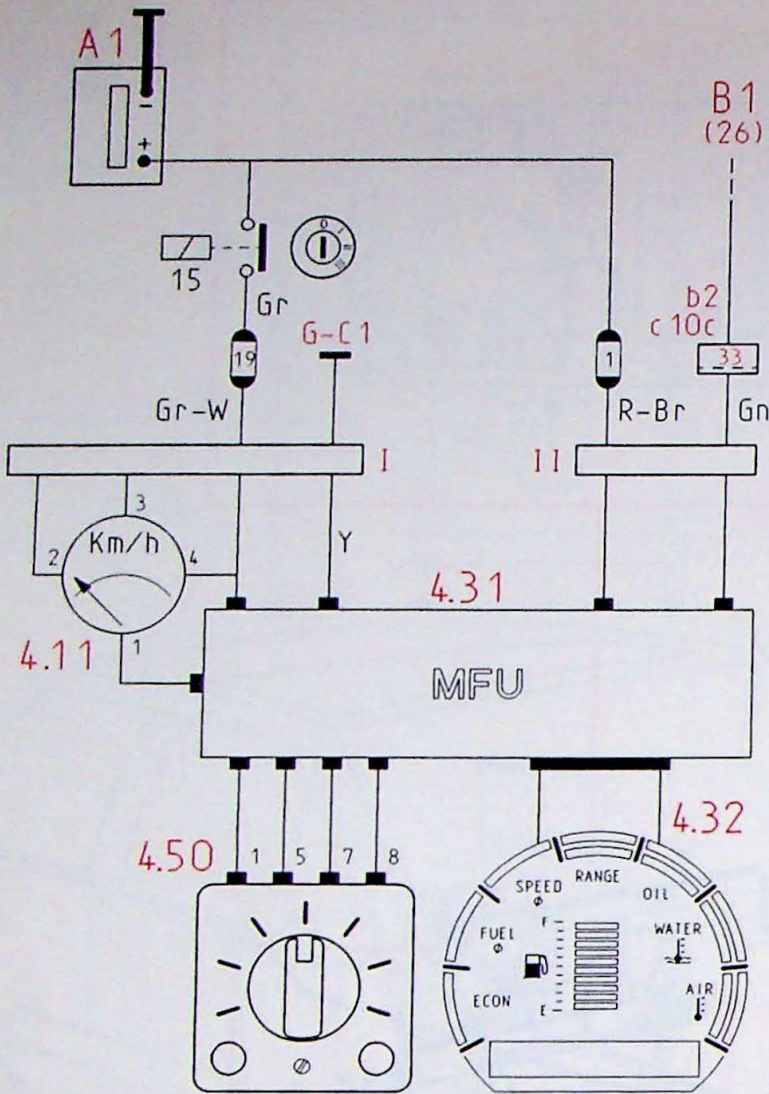

- 4.11 Elektronische snelheidsmeter
- 4.31 MFU (Multi-function-unit)
- 4.32 Informatiecentrum (LCD-paneel)
- 4.50 Kanaalschakelaar, informatiecentrum
- B1 Stuureenheid (ECU), brandstofinspuitsysteem

"Aktueel brandstofverbruik" gekozen (ECON), "6,9 l/100 km" getoond

"Gemiddeld brandstofverbruik" gekozen (FUEL AVG), "8,2 l/100 km" getoond

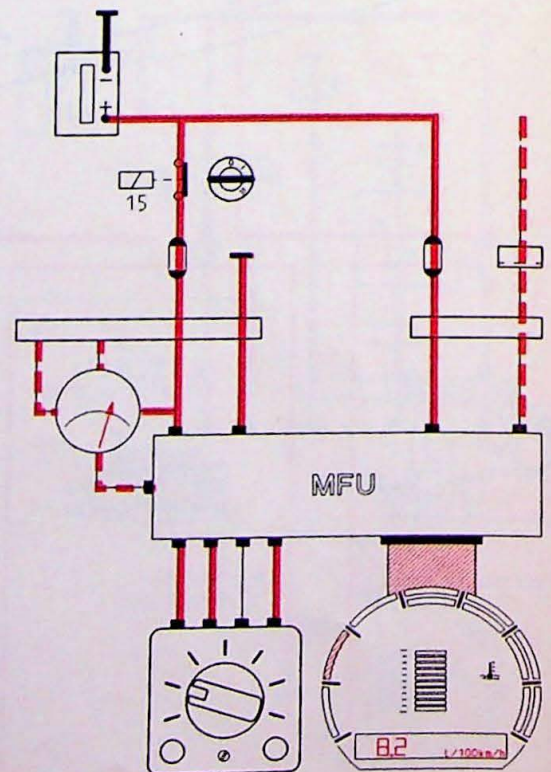
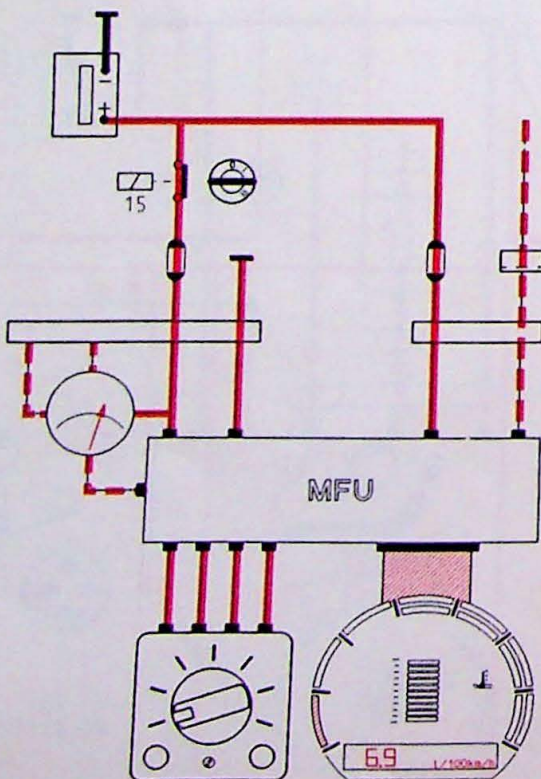

8-013/031

# Informatiecentrum, brandstofverbruik

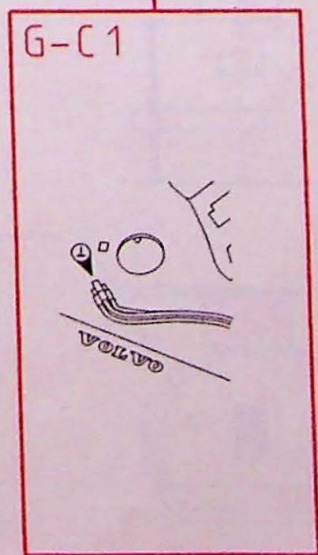
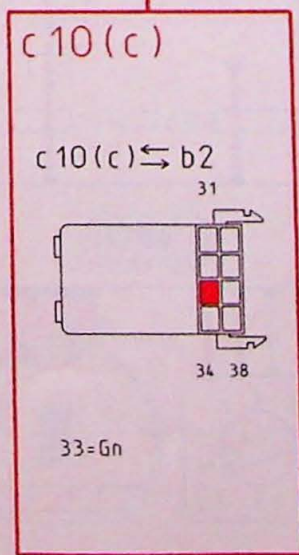
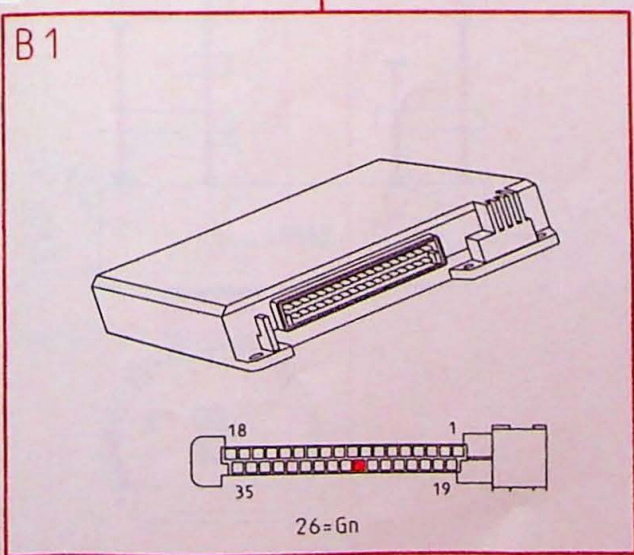
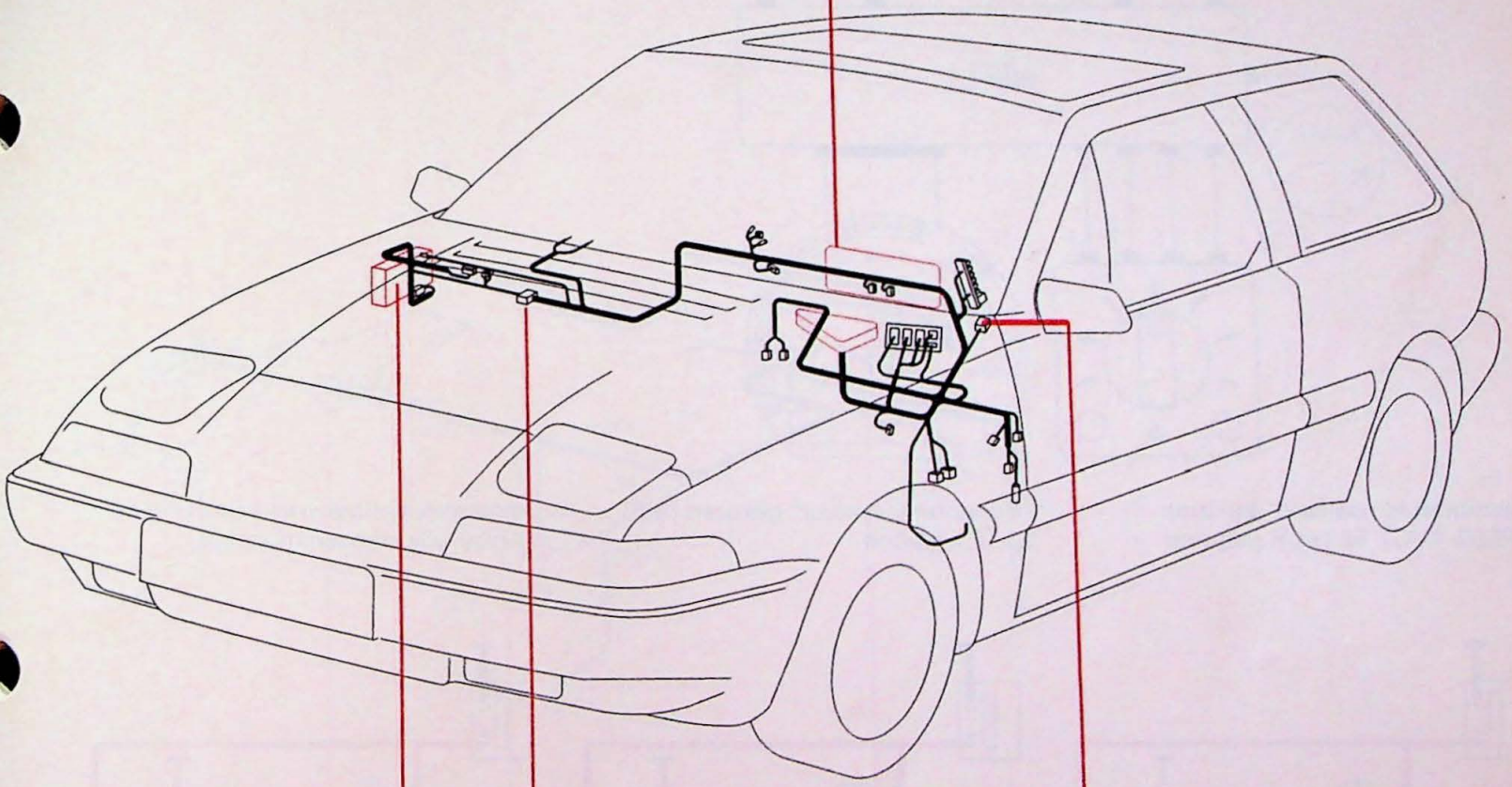
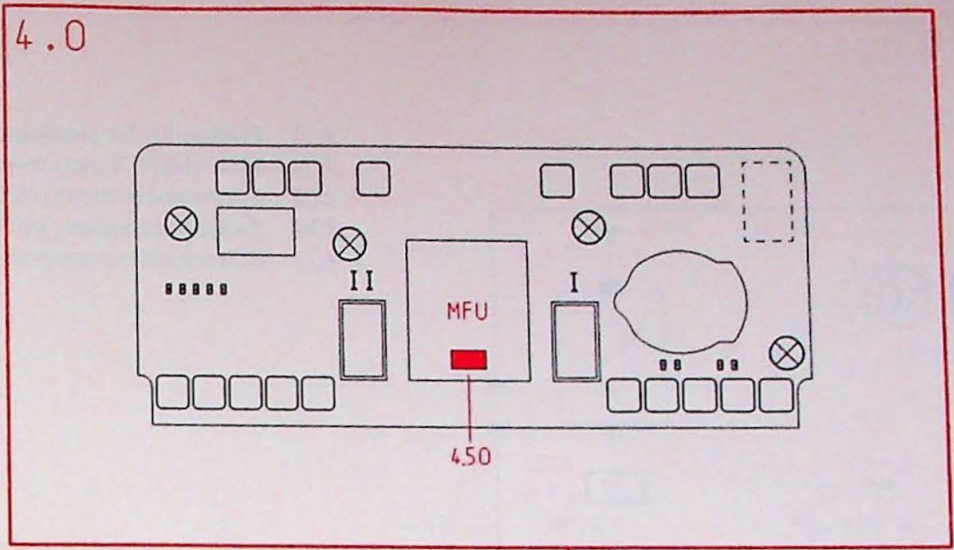

# Informatiecentrum, gemiddelde snelheid en buitentemperatuur

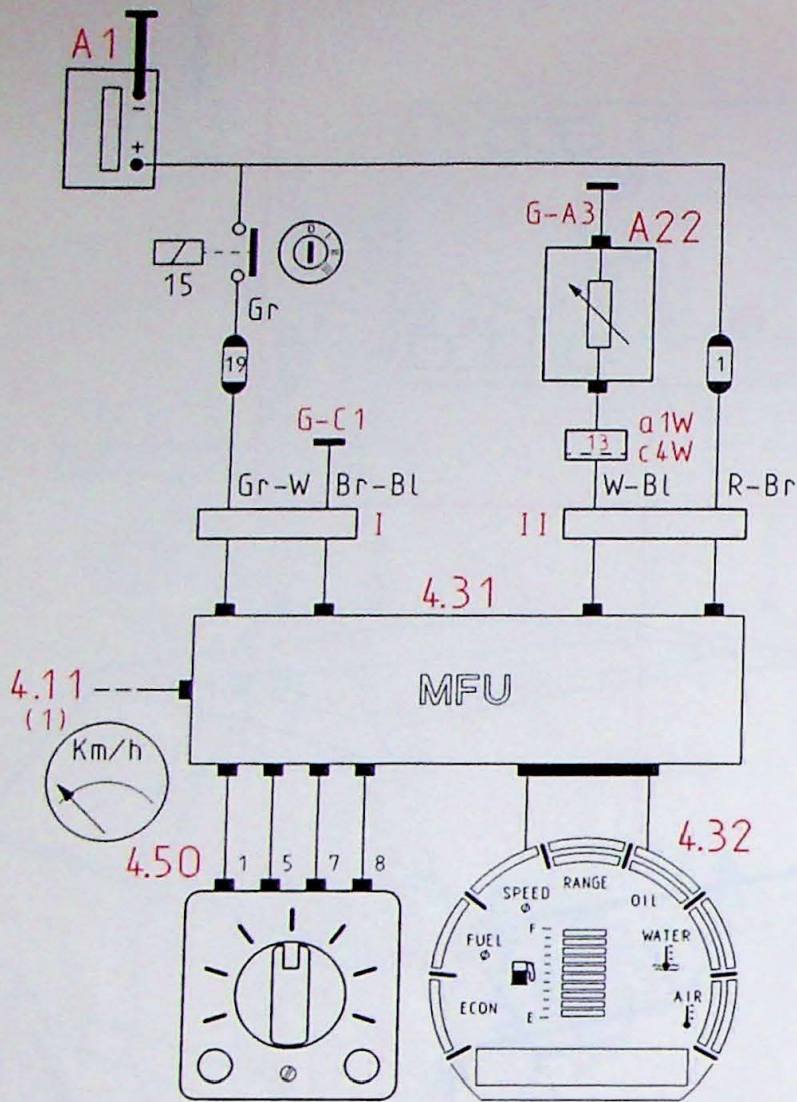

- 4.11 Elektronische snelheidsmeter
- 4.31 MFU (Multi-function-unit)
- 4.32 Informatiecentrum (LCD-paneel)
- 4.50 Kanaalschakelaar, informatiecentrum
- A22 Buitenluchttemperatuurgever

"Gemiddelde snelheid" gekozen (SPEED AVG), 58 km/h getoond

"Buitentemperatuur" gekozen (AIR), 23 °C getoond

Buitentemperatuur waarschuwing op display, alle standen mogelijk

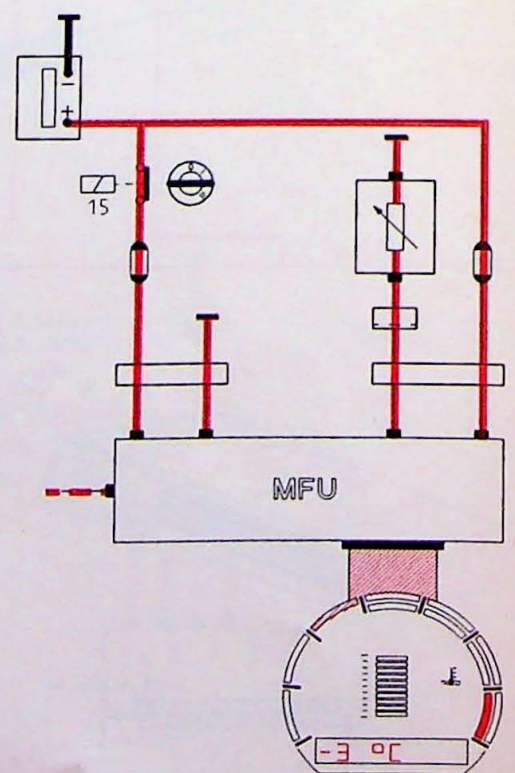
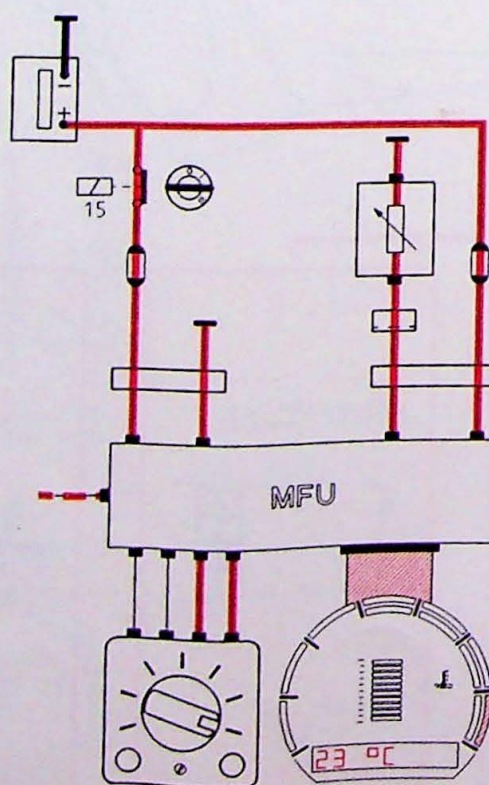
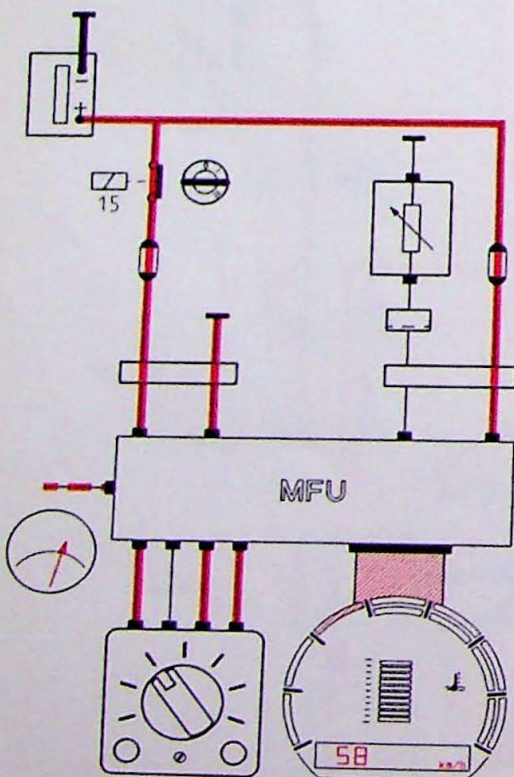

# Informatiecentrum, gemiddelde snelheid en buitentemperatuur

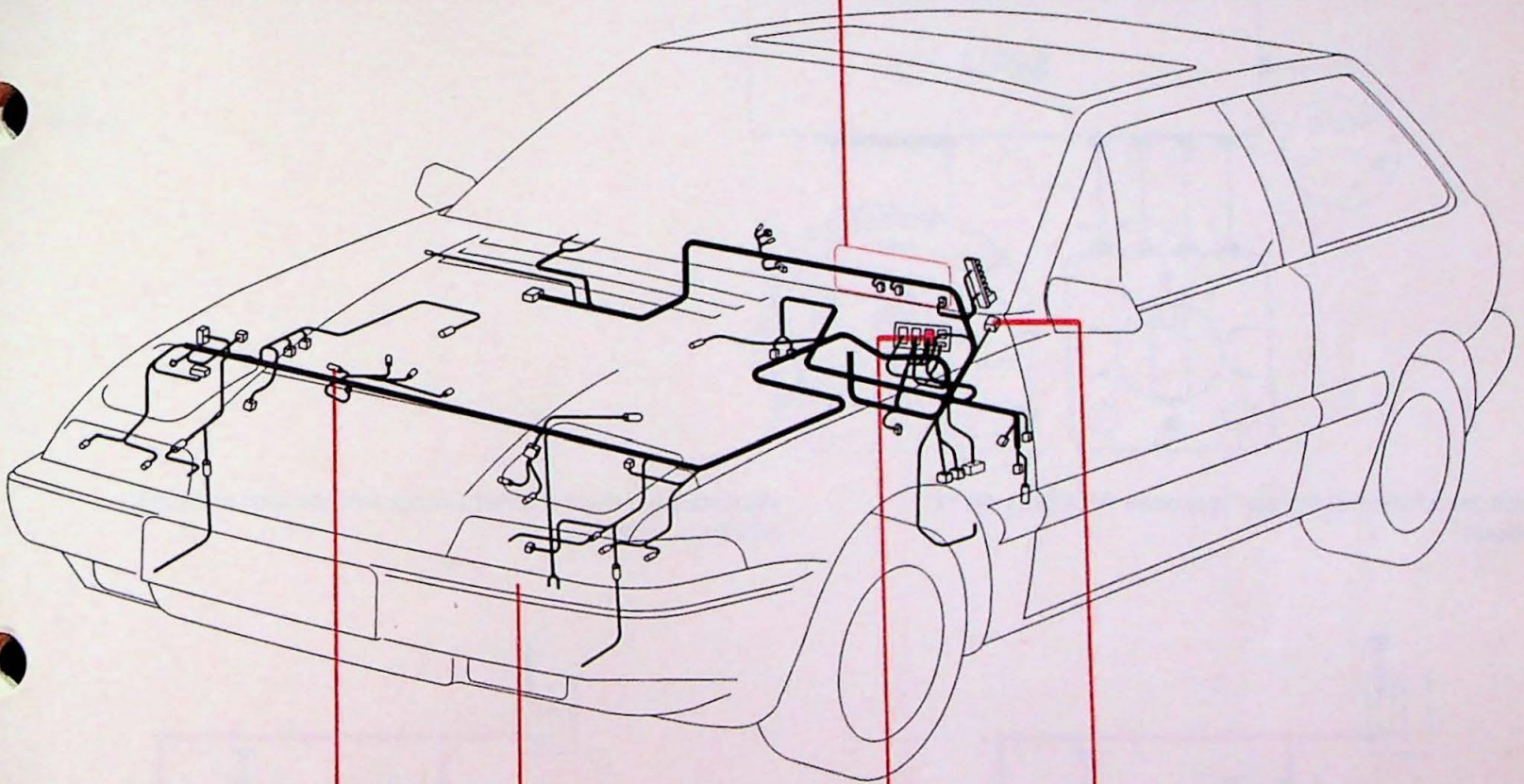
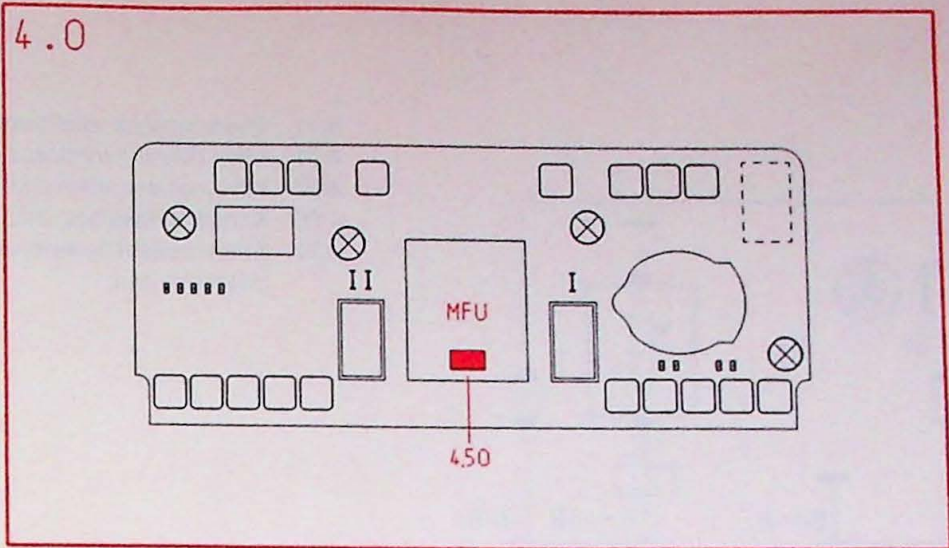

G-A3



A22

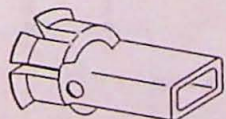

W-BI  
Br

c4W

c4W ↔ a1W

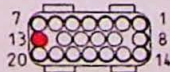

13=W-BI

G-C1

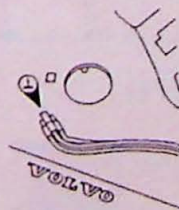

# Informatiecentrum, koelvloeistoftemperatuur

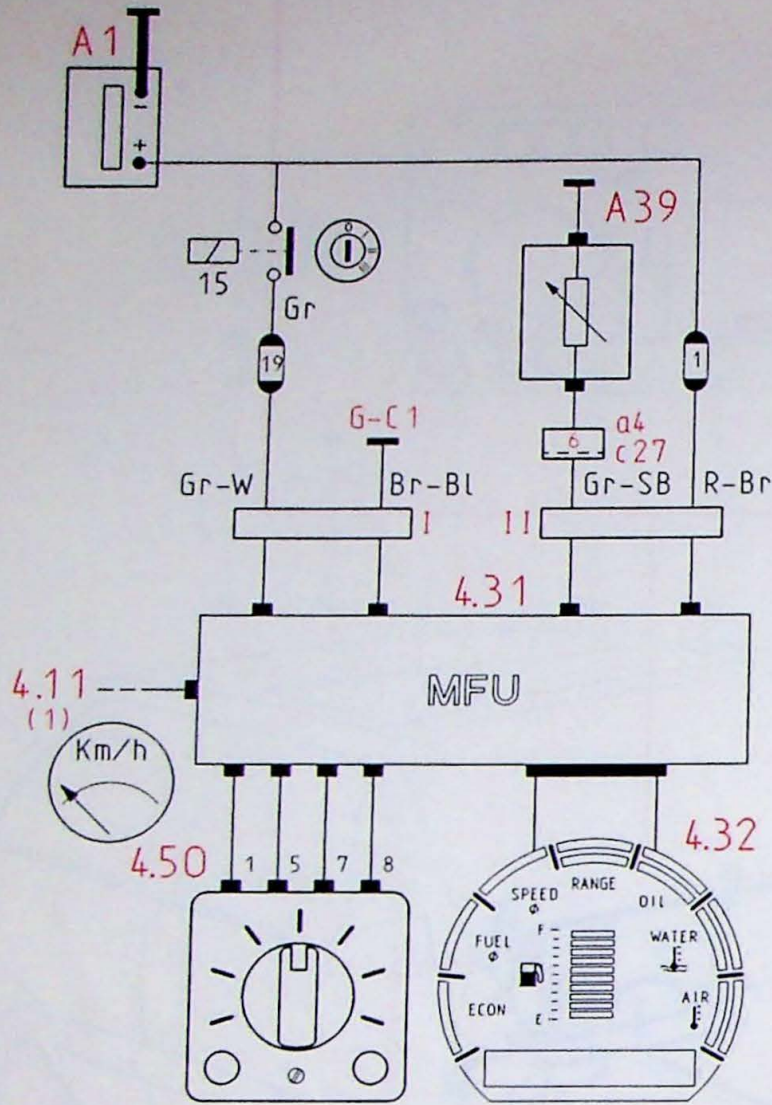

- 4.11 Elektronische snelheidsmeter
- 4.31 MFU (Multi-function-unit)
- 4.32 Informatiecentrum (LCD-paneel)
- 4.50 Kanaalschakelaar, informatiecentrum
- A39 Koelvloeistof-temperatuurgever, instrumenten

"Koelvloeistoftemperatuur" gekozen (WATER), 96 °C getoond

Watertemperatuur waarschuwing, alle standen mogelijk, STOP op display

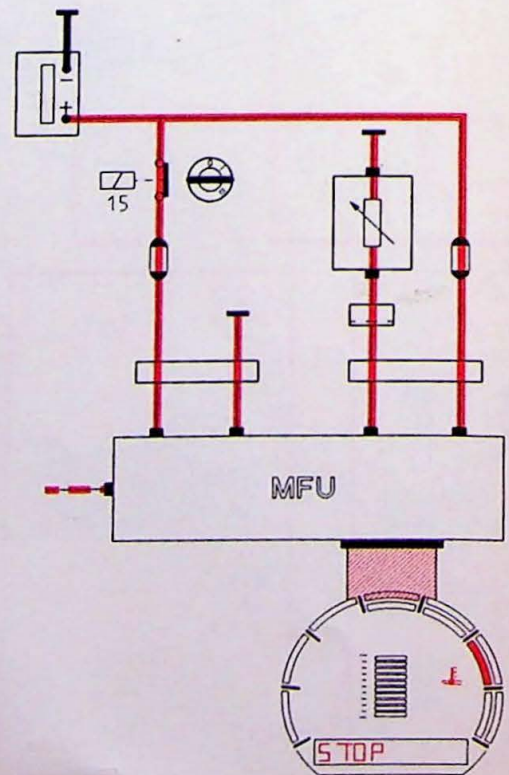
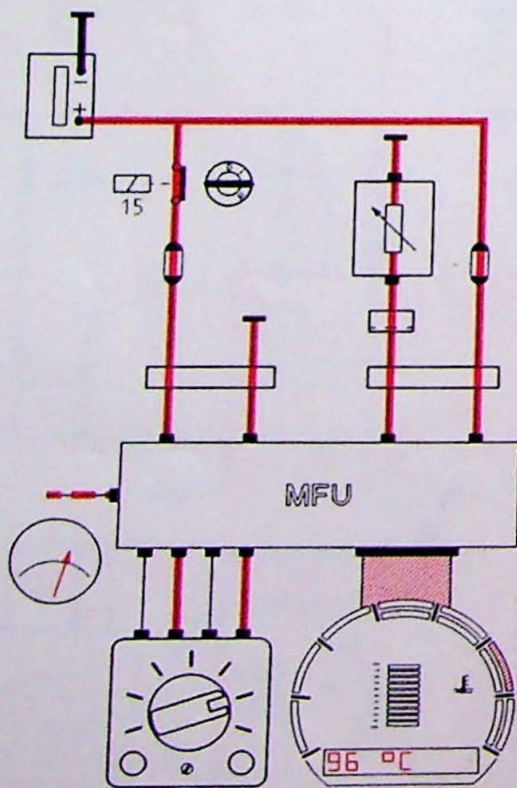

8-013/029

# Informatiecentrum, koelvloeistoftemperatuur

4.0

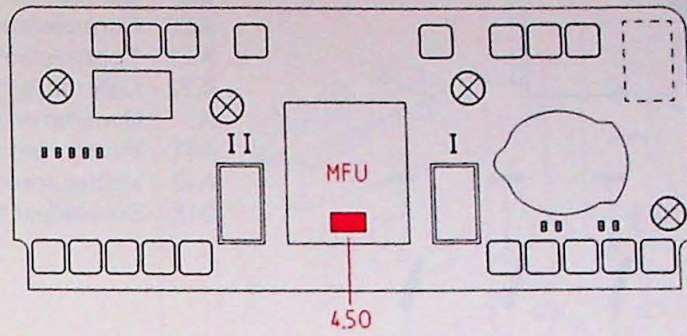

4.50

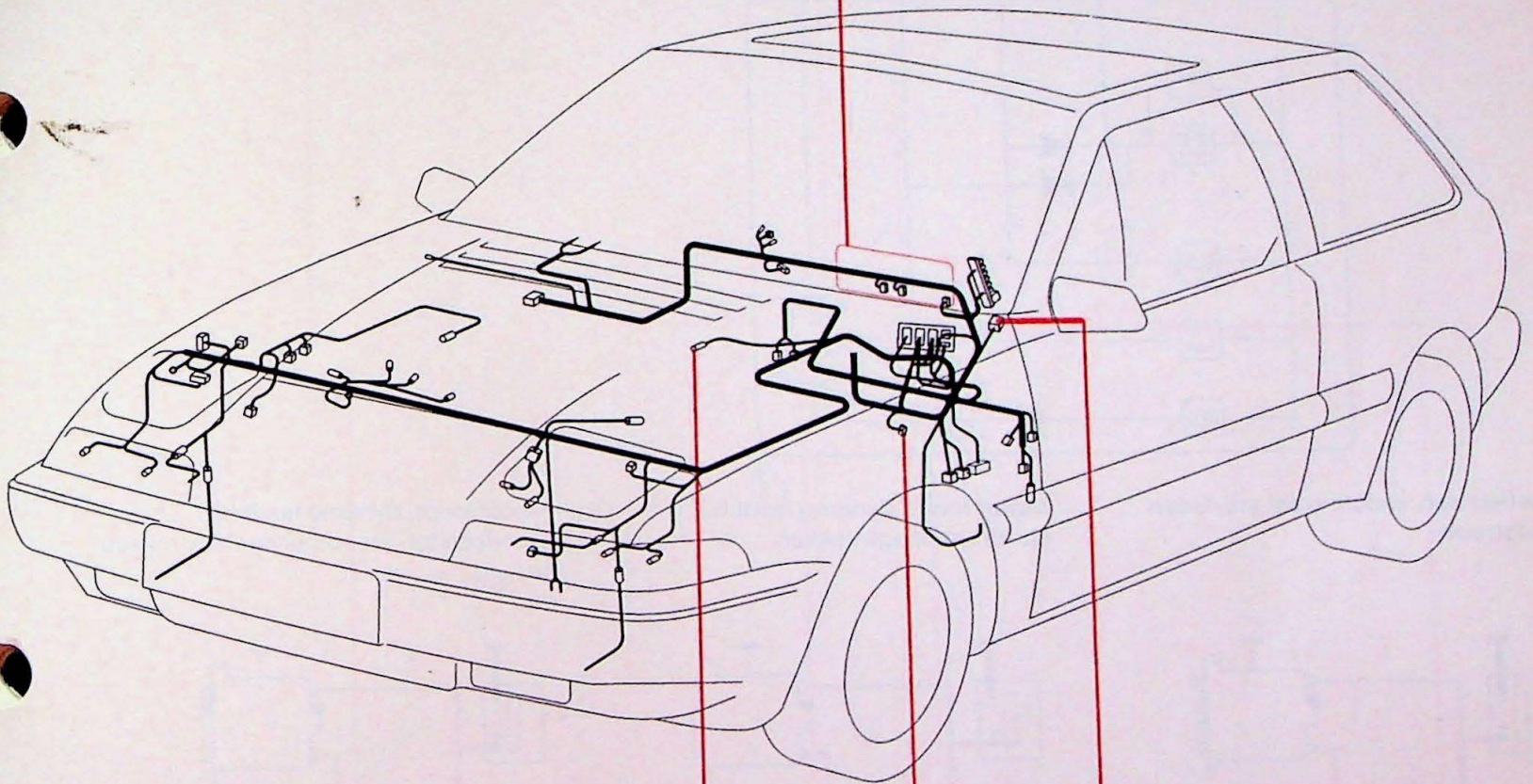

A39

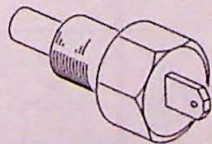

Gn-SB

c27

c27 ↔ a4



6 = Gr-SB

G-C1



# Controlelampen, remvloeistof, handrem, laadstroom en sproeivloeistof

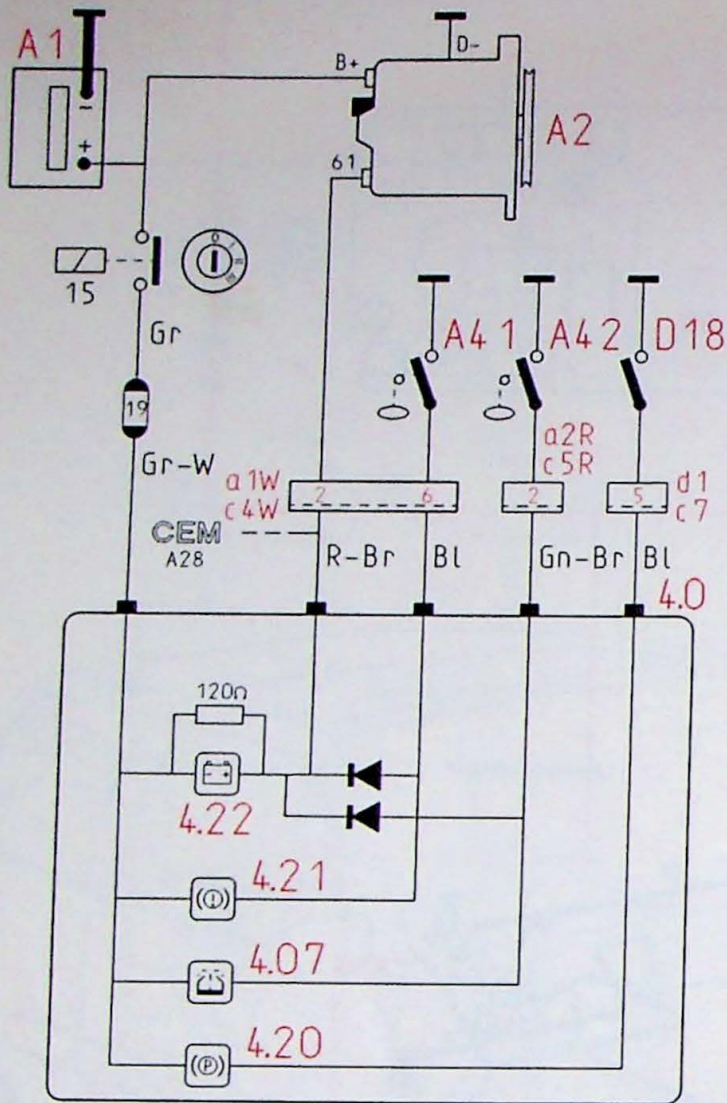

- 4.07 Controlelamp, laag sproeiwaterpeil
- 4.20 Controlelamp, handrem
- 4.21 Controlelamp, remvloeistof
- 4.22 Controlelamp, laadstroom
- A2 Dynamo en spanningsregelaar
- A41 Vlotter remvloeistofcontrole
- A42 Vlotter sproeivloeistofcontrole
- D18 Schakelaar handrem

Contact aan, motor staat stil. Geen laadstroom

Motor loopt, dynamo laadt bij, handrem aangetrokken

Motor loopt, dynamo laadt bij, remvloeistof- en sproeivloeistofniveau te laag

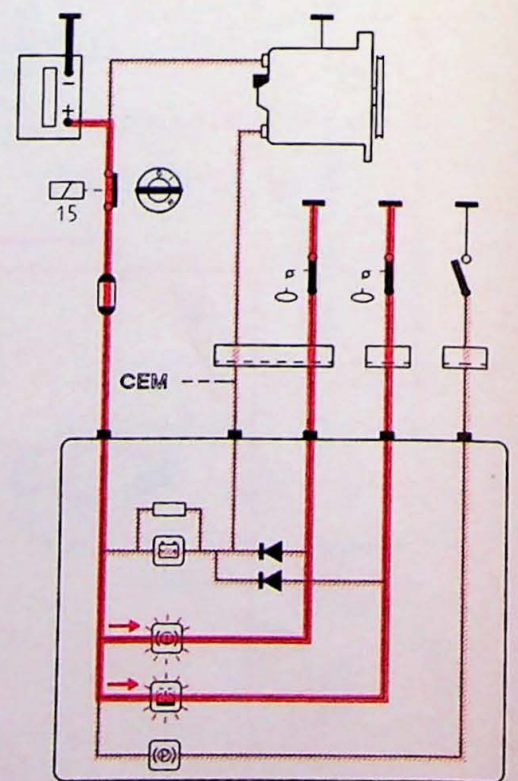
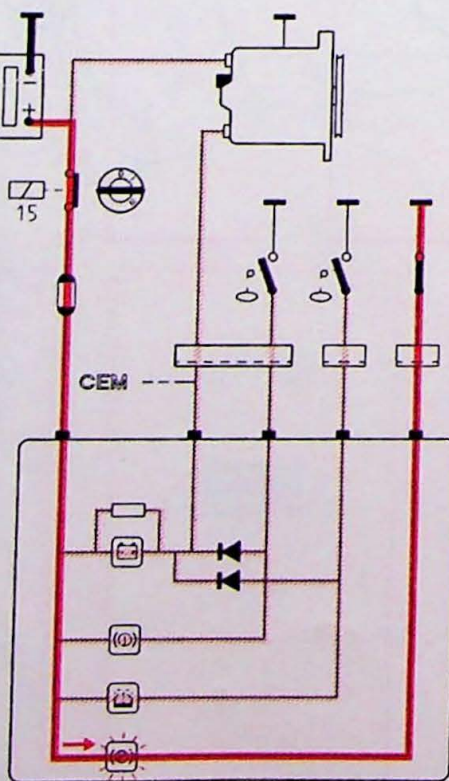
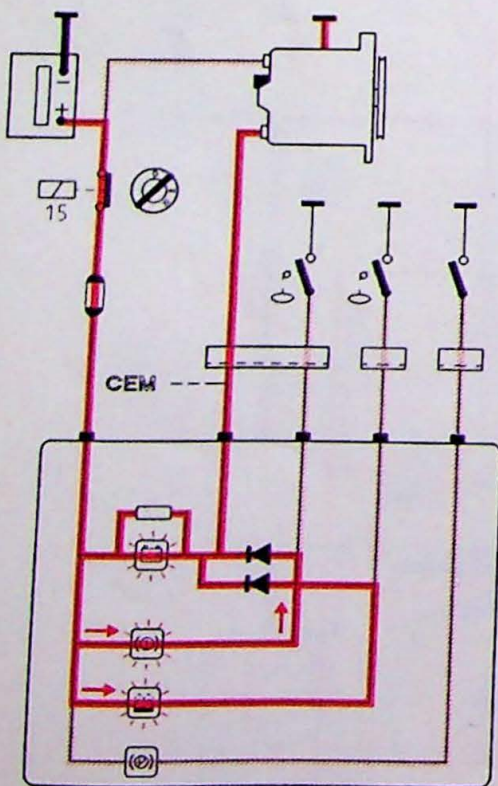

8-013/005

# Controlelampen, remvloeistof, handrem, laadstroom en sproeivloeistof

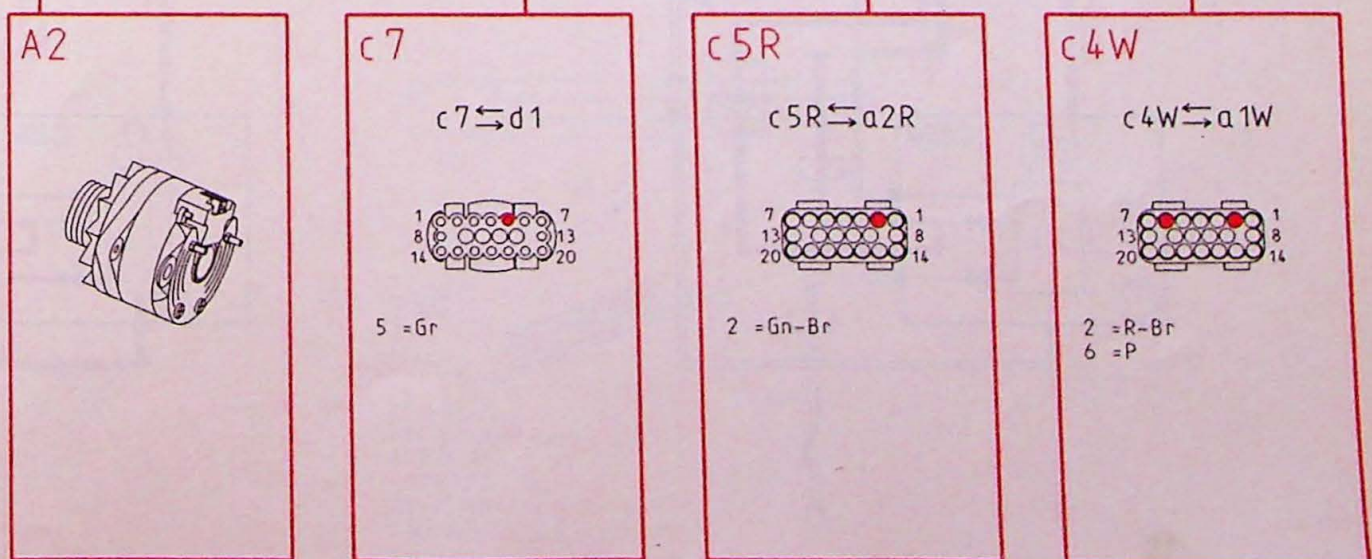
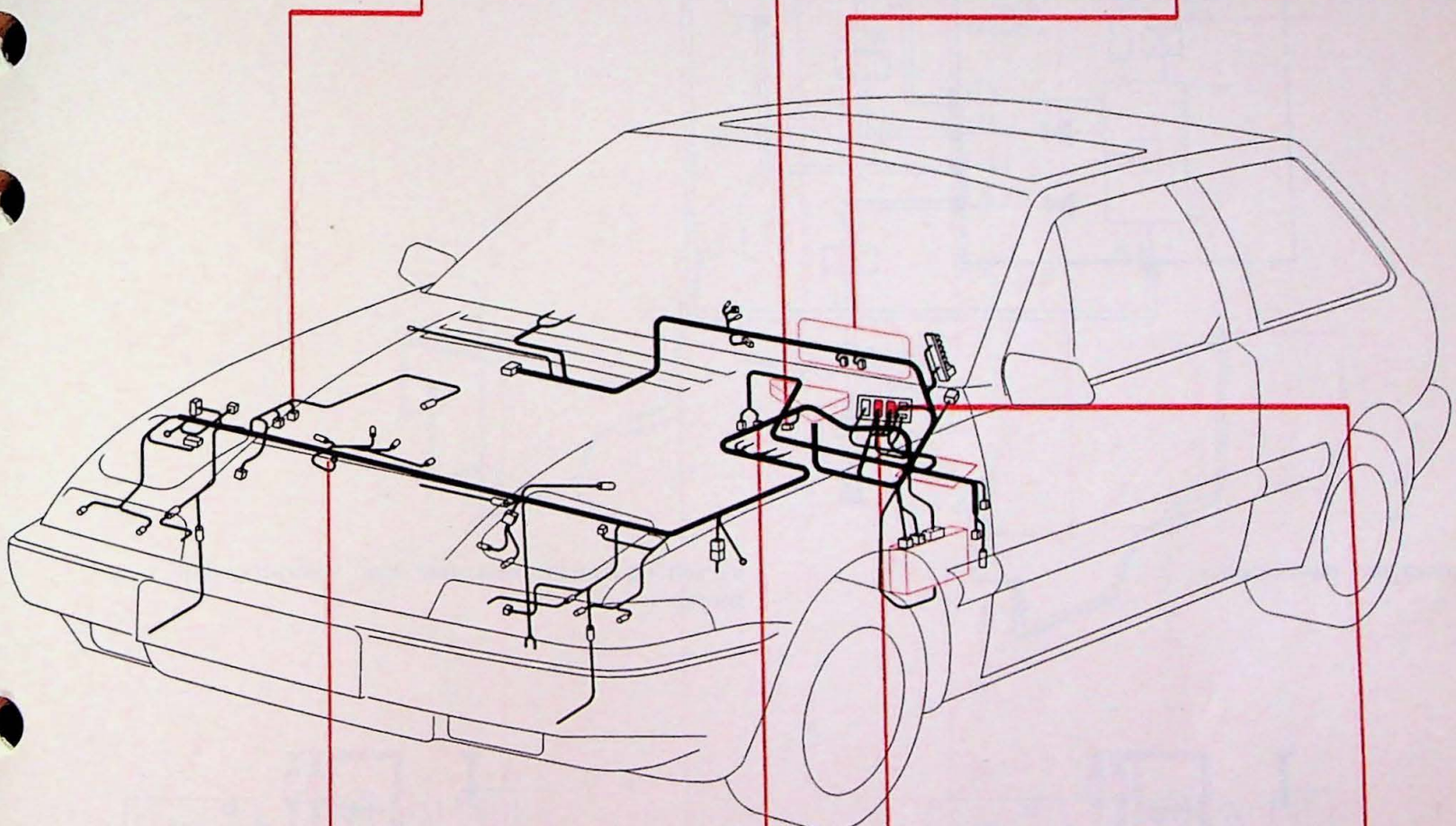
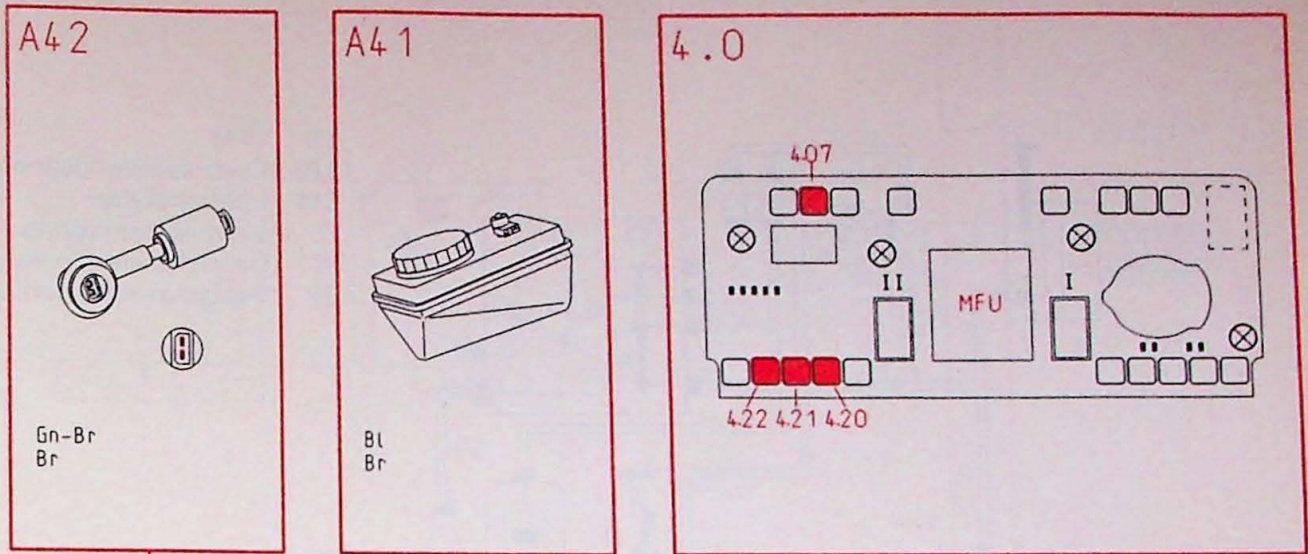

# Controlelamp "deur open" en zoemerverlichting

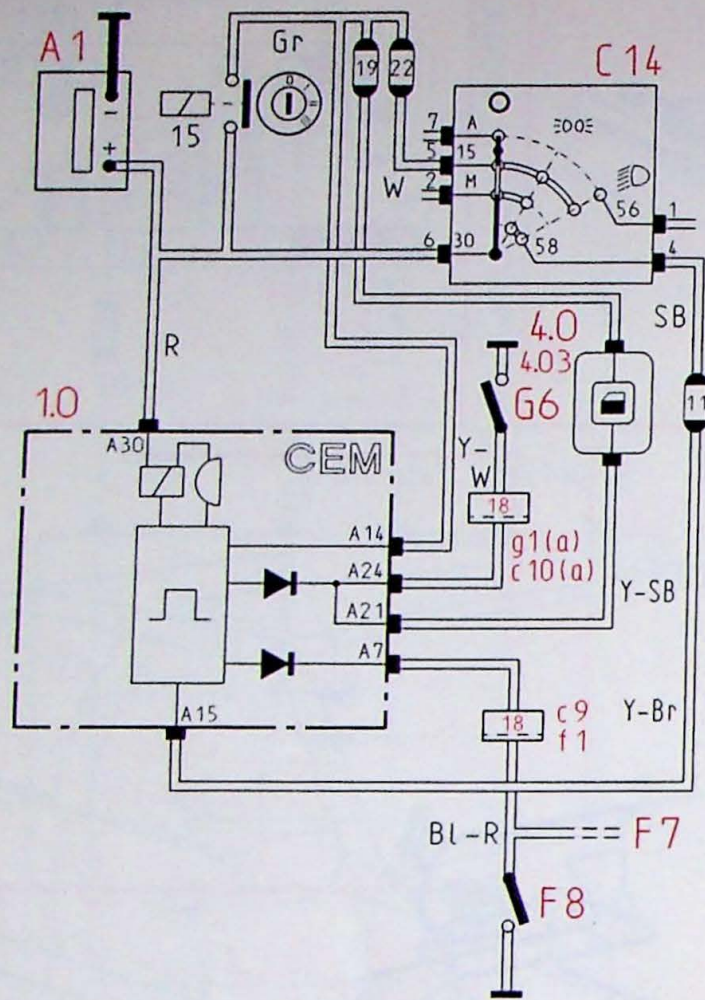

- 1.0 CEM
- 4.03 Controlelamp "deur open"
- C14 Lichtschakelaar
- F7 Sleutelgatverlichting
- F8 Deurschakelaar, portier bestuurder
- G6 Deurschakelaar, portier passagier

Contact aan, deur open

Verlichting ingeschakeld, deur open, waarschuwing zoemer

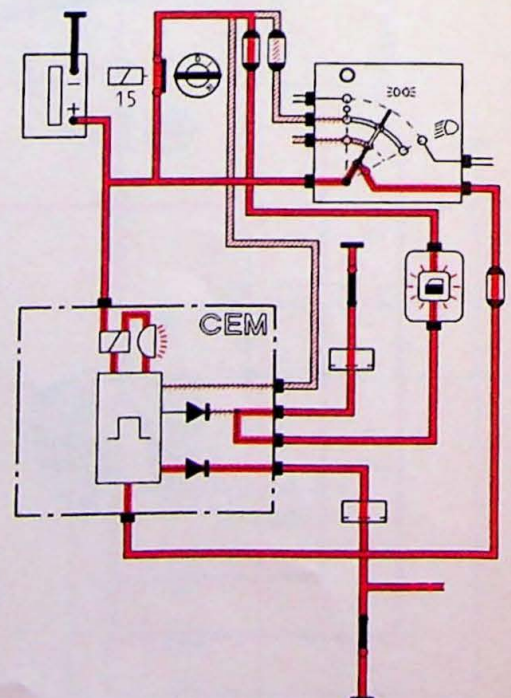
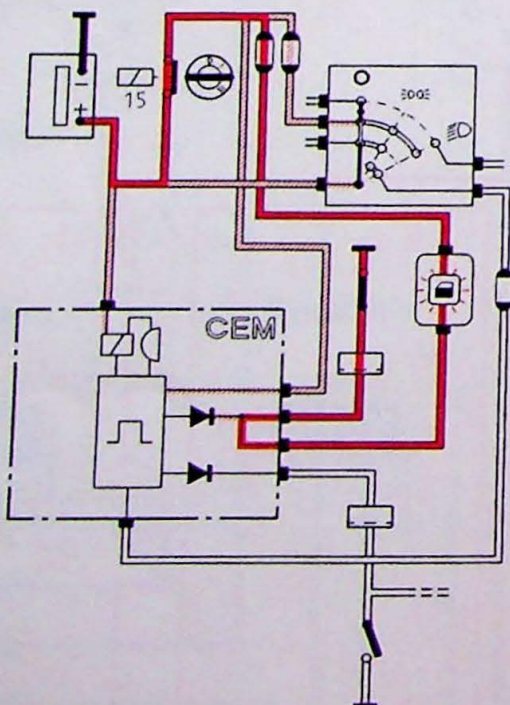

8-013/050

# Controlelamp "deur open" en zoemerverlichting

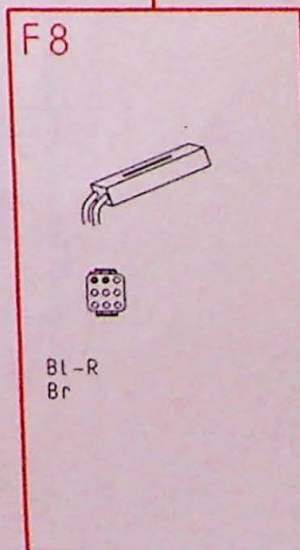
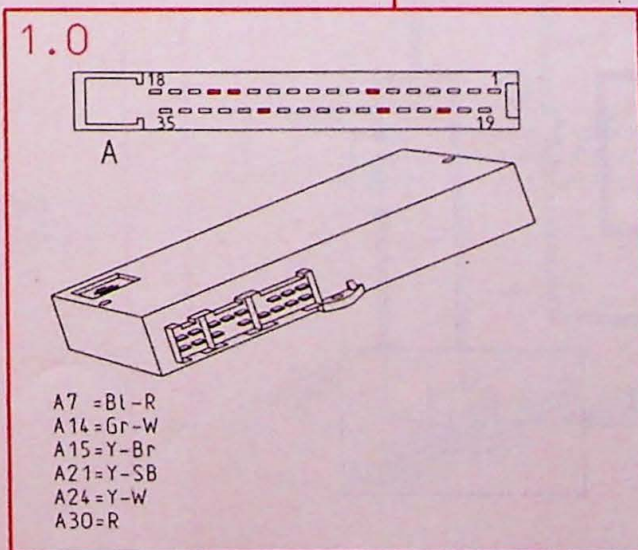
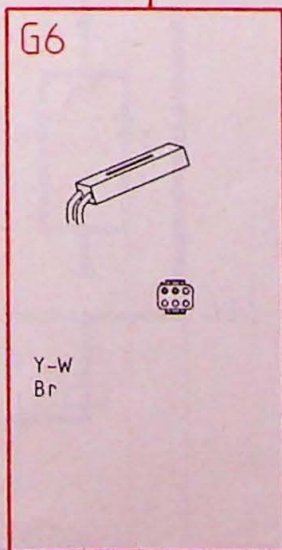
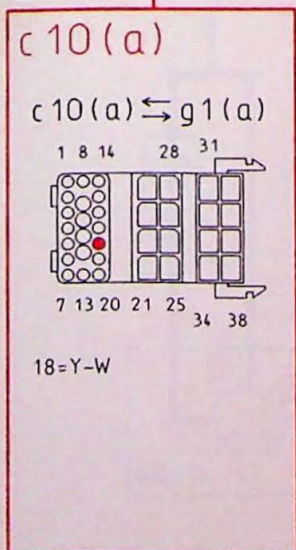
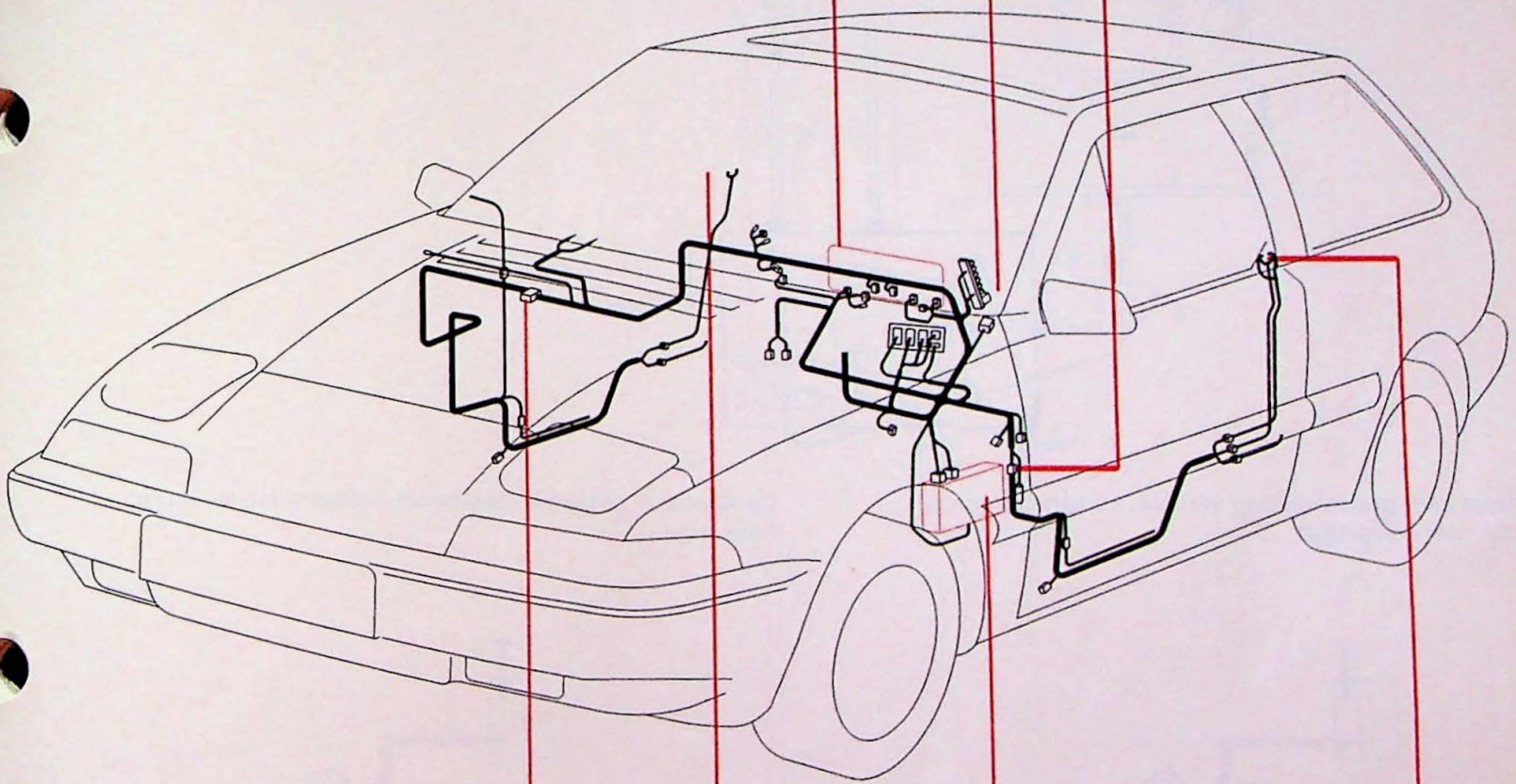
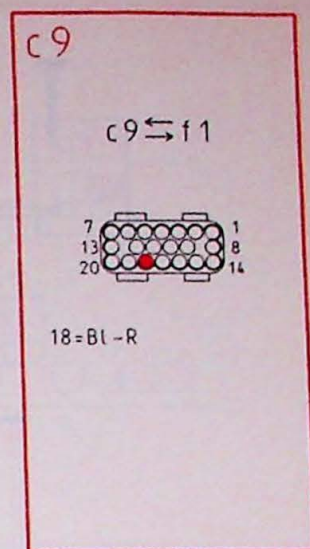
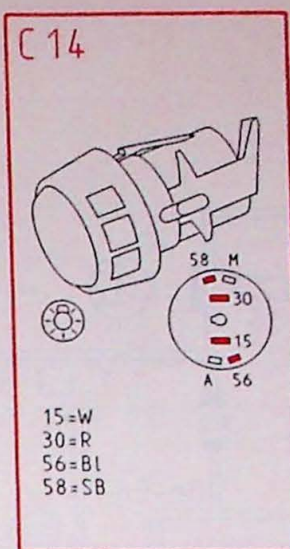
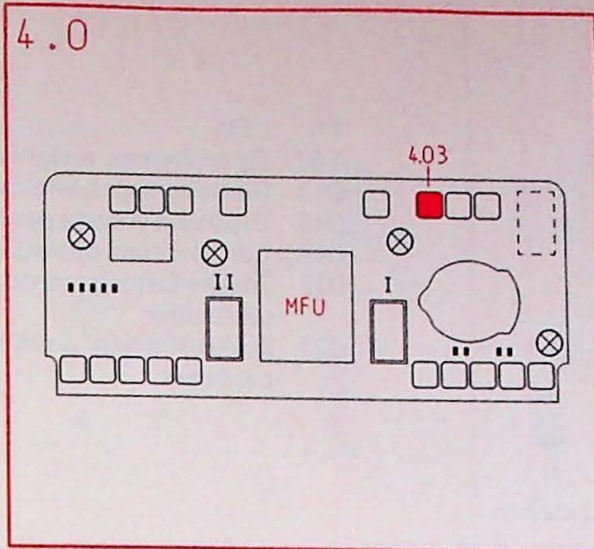

# Controlelamp, veiligheidsgordels

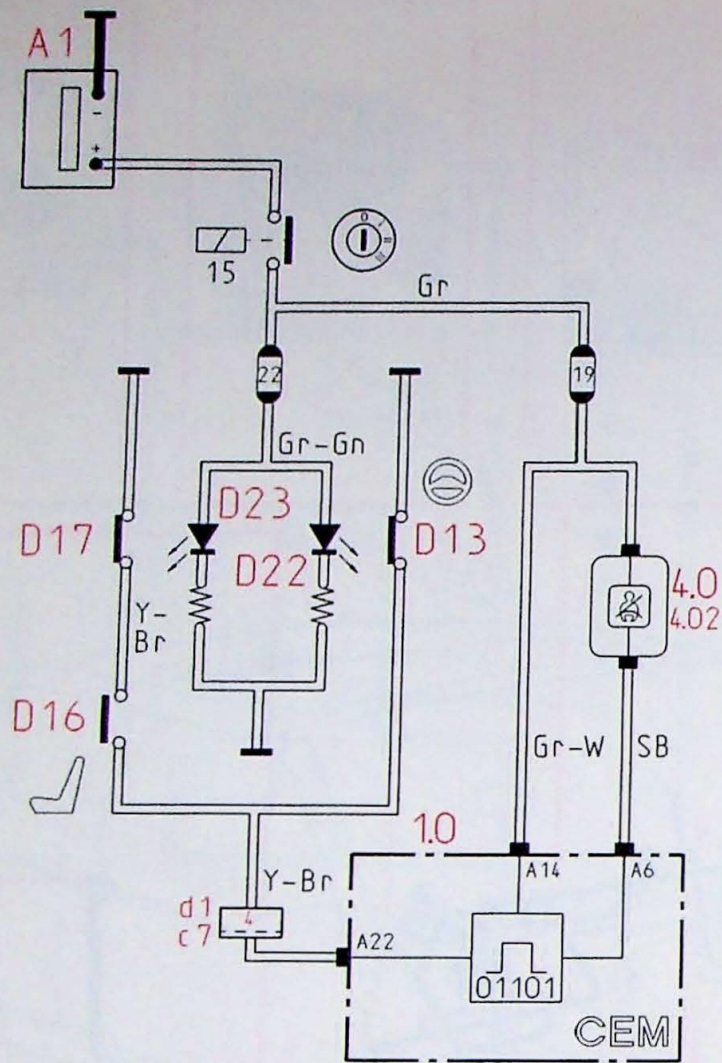

- 1.0 CEM
- 4.02 Controlelamp, veiligheidsgordels
- D13 Gordelcontact bestuurder
- D16 Zitcontact voorste passagiersstoel
- D17 Gordelcontact passagier
- D22 Zoekverlichting, gordelsluiting bestuurder
- D23 Zoekverlichting, gordelsluiting passagier

Contact aan, gordelsluiting verlicht, veiligheidsgordel bestuurder bevestigd

Contact aan, passagierstoel bezet, veiligheidsgordel niet bevestigd

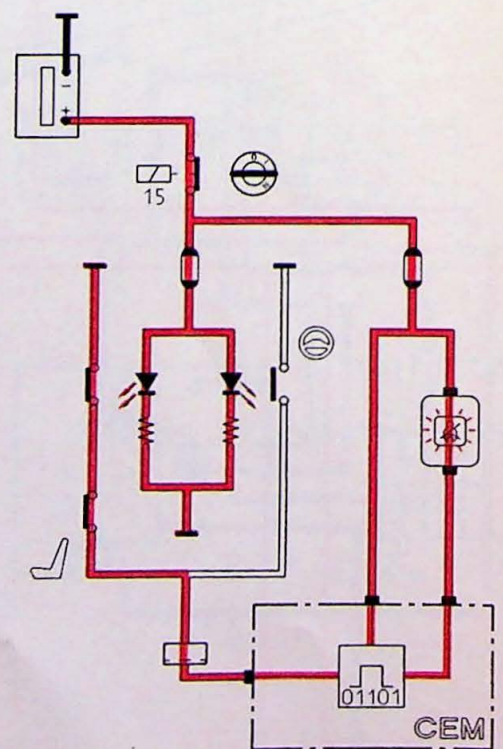
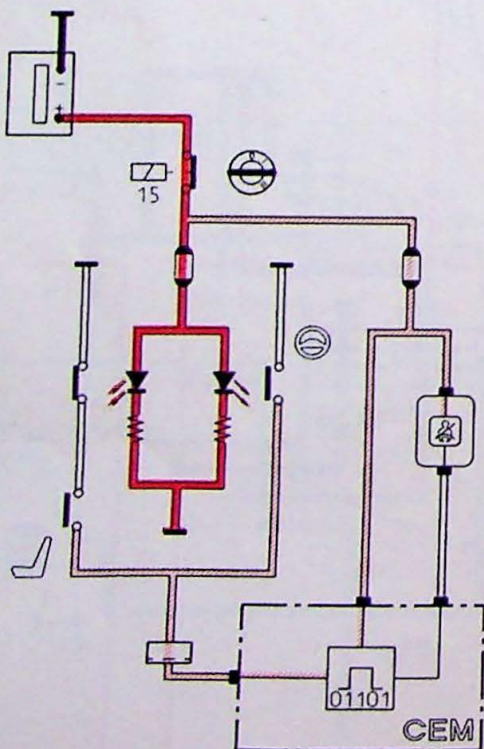

8-013/003

# Controlelamp, veiligheidsgordels

D17-D13

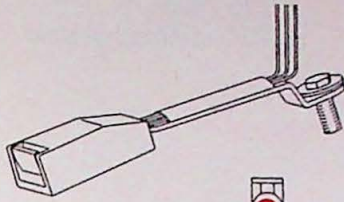

- 1 = Br
- 2 = Y-Br
- 3 = Gr-Gn



4.0

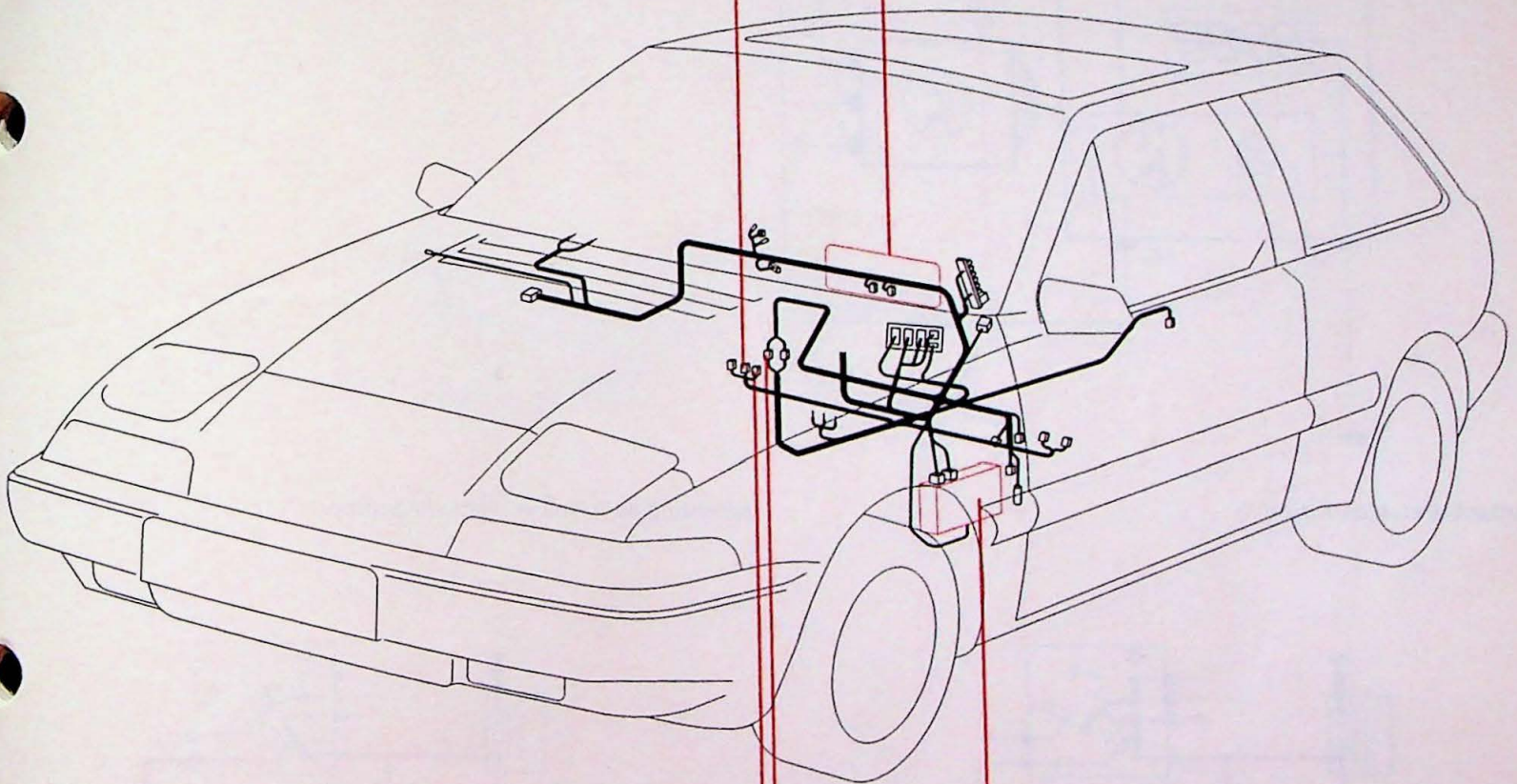
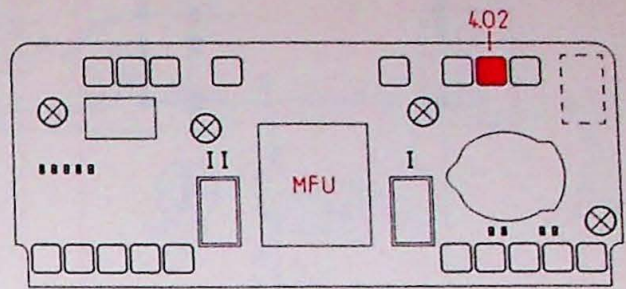

D16

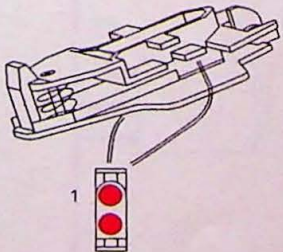

- 1 = Y-Br
- 2 = Y-Br

c7

c7 ↔ d1

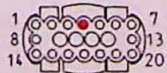

- 4 = Y-Br

1.0

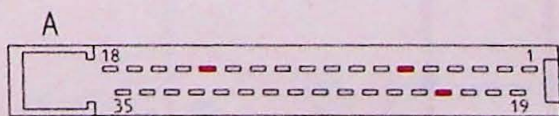

- 6 = SB
- 14 = Gr-W
- 22 = Y-Br

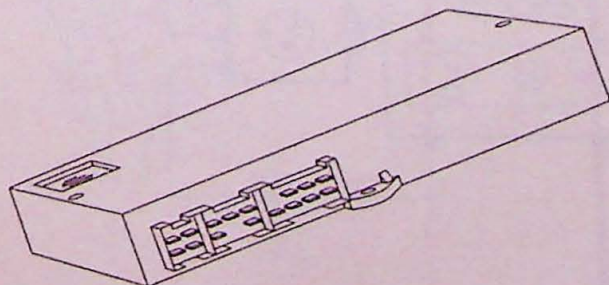

# Consoleklok

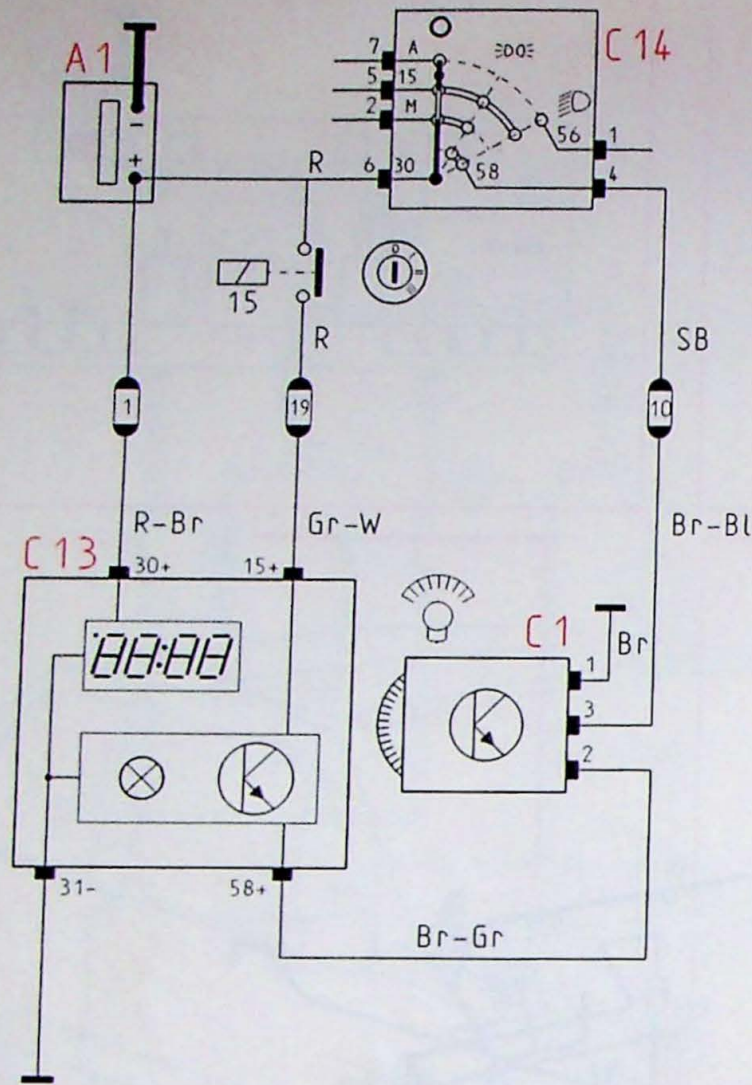

- C1 Dimmer dashboardverlichting
- C13 Klok
- C14 Lichtschakelaar

Contact aan, klok loopt

Verlichting aan, klok verlicht via dimmer

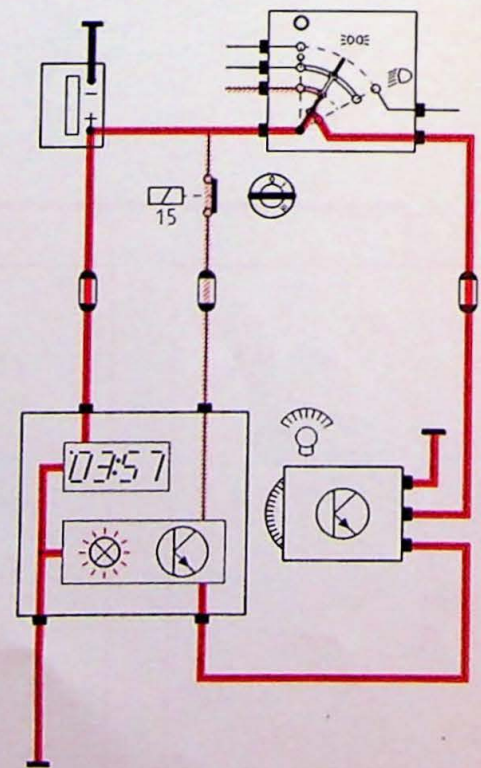
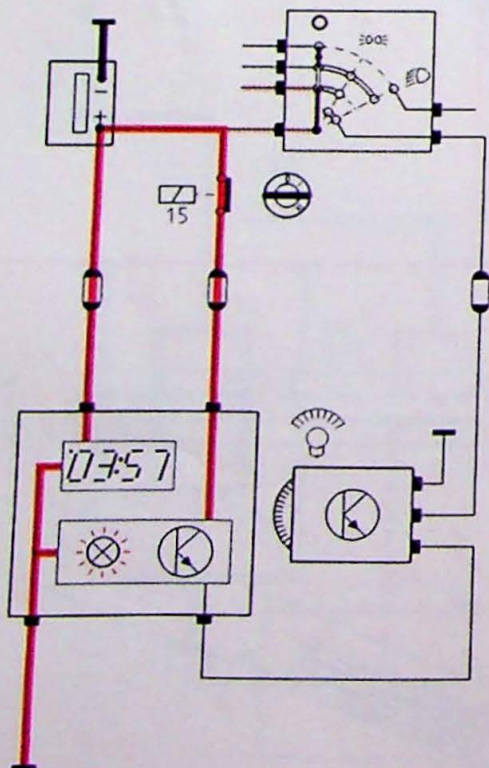

8-013/045

# Consoleklok

C13

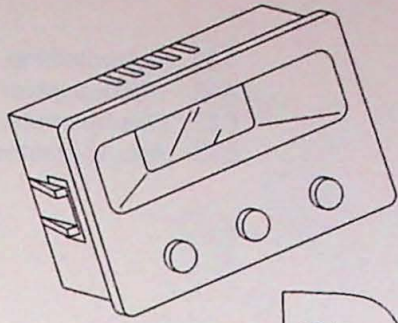

15=Gr-W  
30=R-Br  
31=Br  
58=Br-Gr

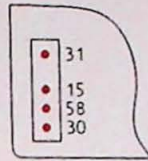

C14

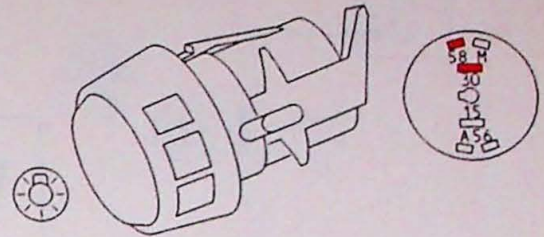

30=R  
58=SB

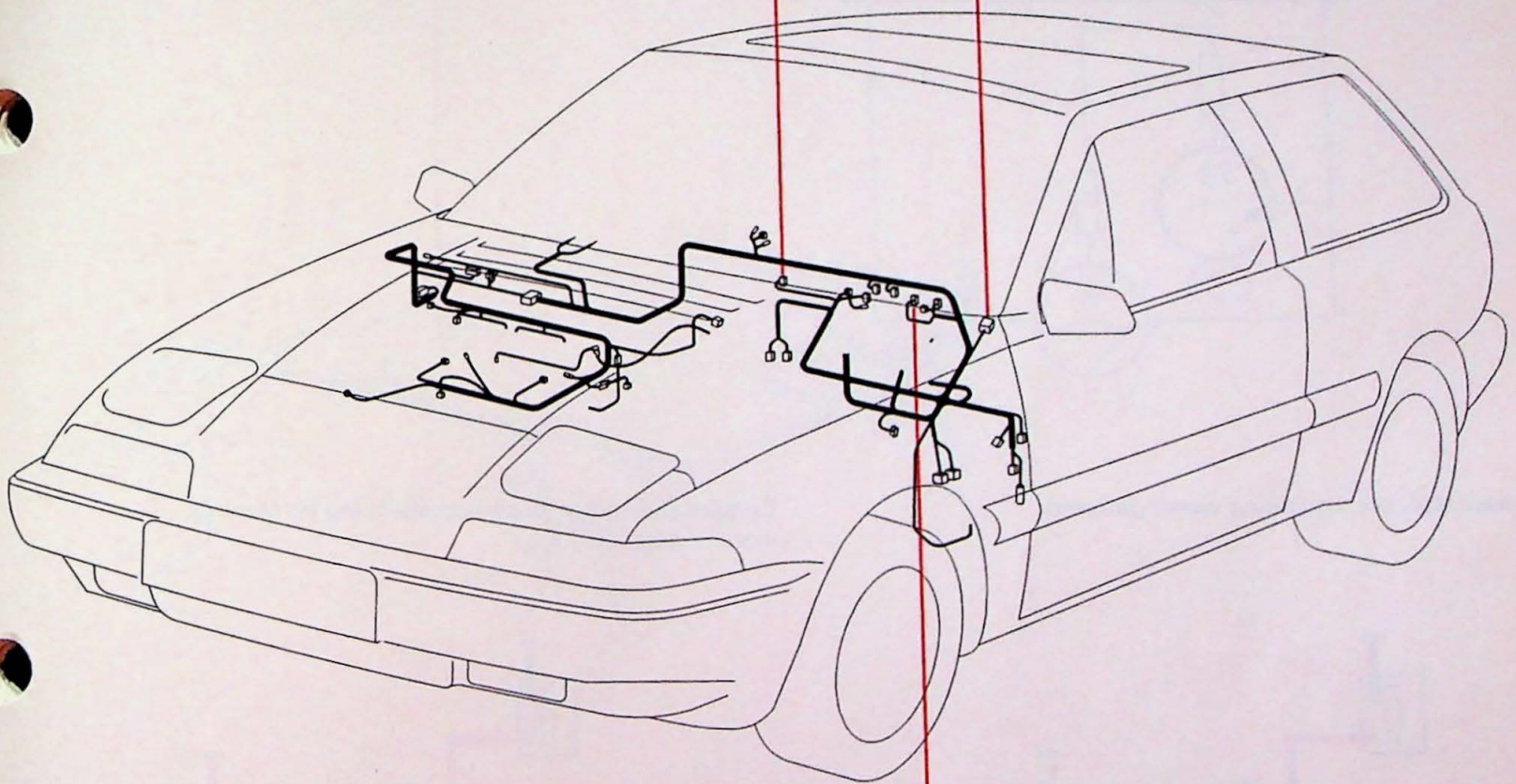

C1

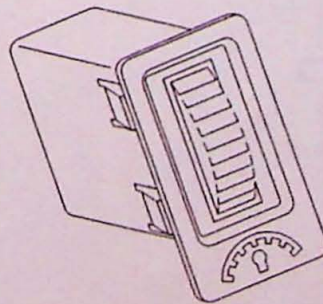

1 =Br  
2 =Br-Gr  
3 =Br-Bl

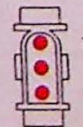

# Accuvolt- en oliedrukmeter

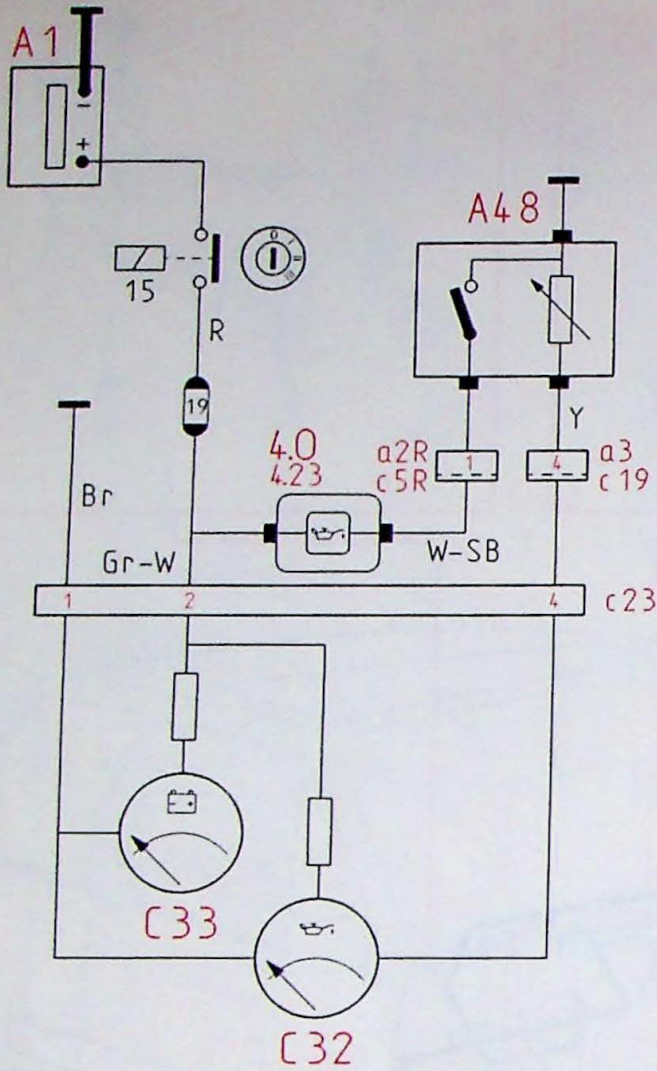

- 4.23 Controlelamp, oliedruk
- A48 Oliedrukgever
- C32 Oliedrukmeter
- C33 Accuvoltmeter

Contact aan, accuspanning wordt getoond

Contact aan, motor loopt, accuspanning en oliedruk worden getoond

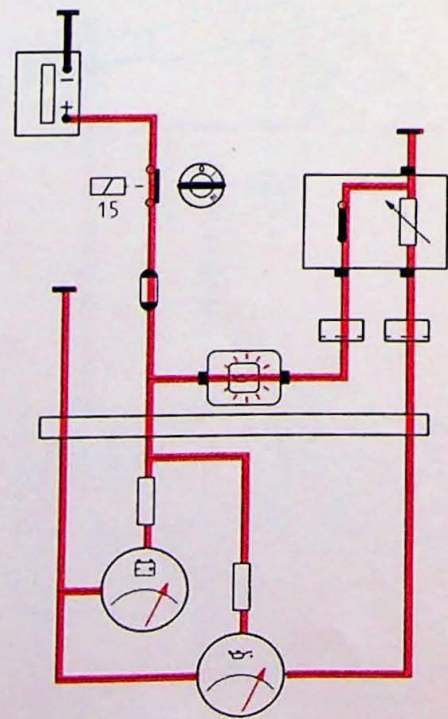
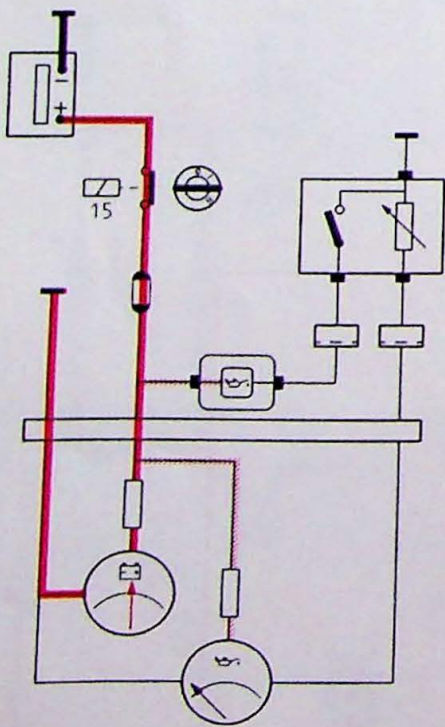

8-013/044

# Accuvolt- en oliedrukmeter

A48

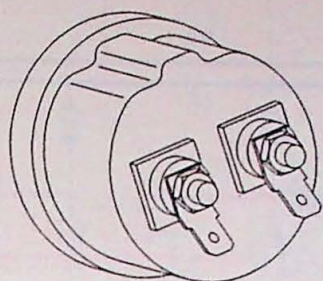

Y  
Br

c 19

c 19 → a3



4 = Y

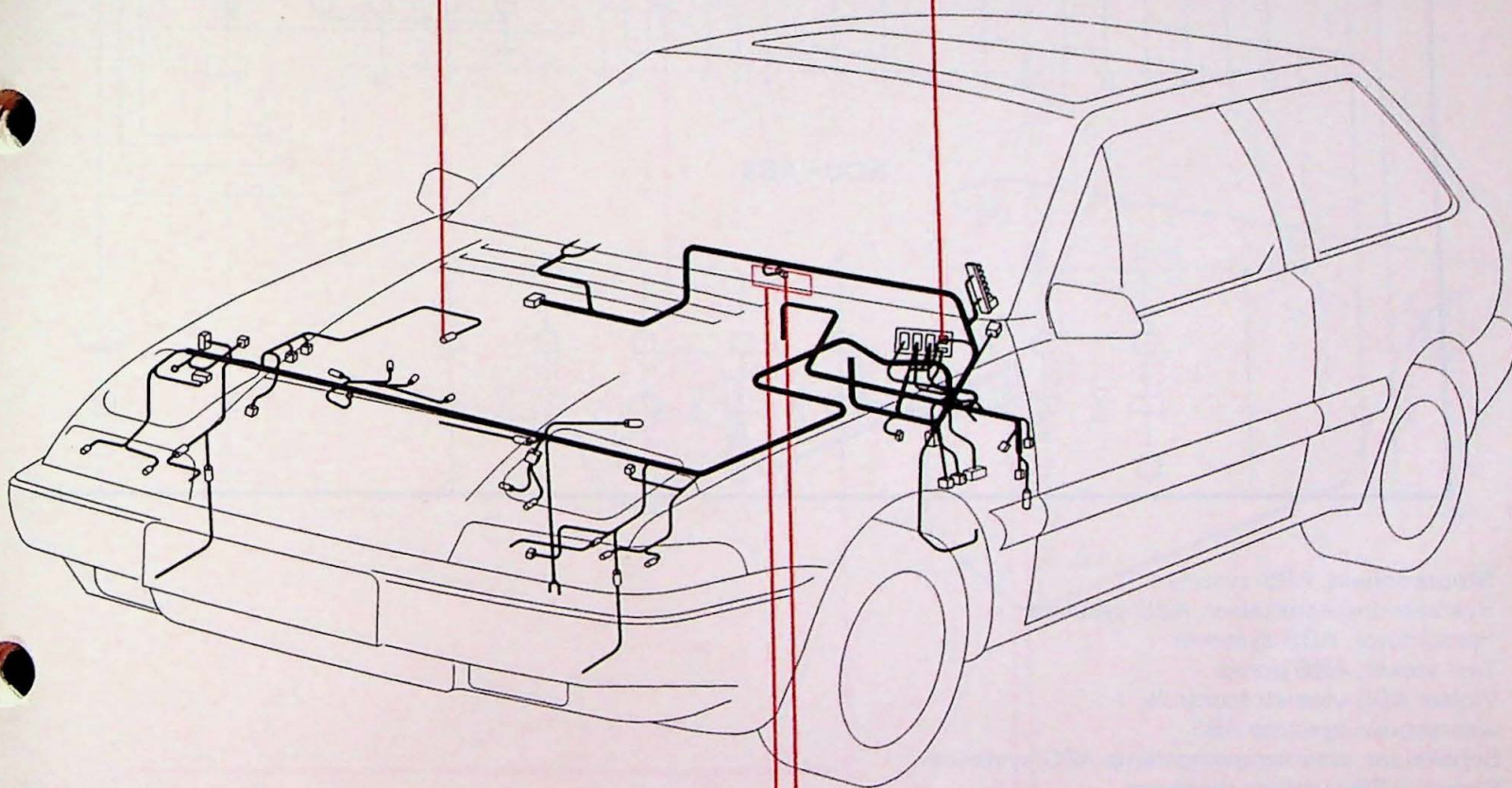

C32-C33

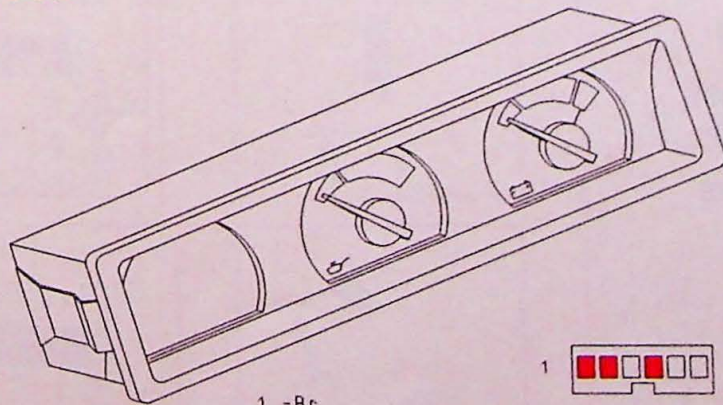

1 = Br  
2 = Gr-W  
4 = Y

c 23

c 23 → 4.32



1 = Br  
2 = Gr-W  
4 = Y

# Accuvolt- en oliedrukmeter

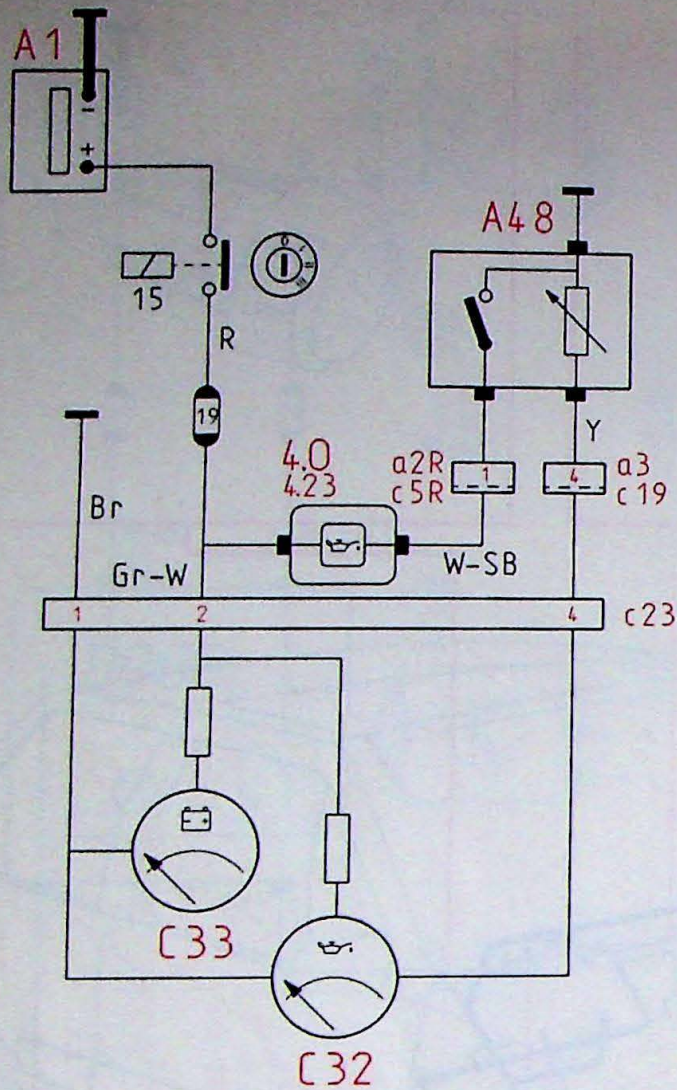

- 4.23 Controlelamp, oliedruk
- A48 Oliedrukgever
- C32 Oliedrukmeter
- C33 Accuvoltmeter

Contact aan, accuspanning wordt getoond

Contact aan, motor loopt, accuspanning en oliedruk worden getoond

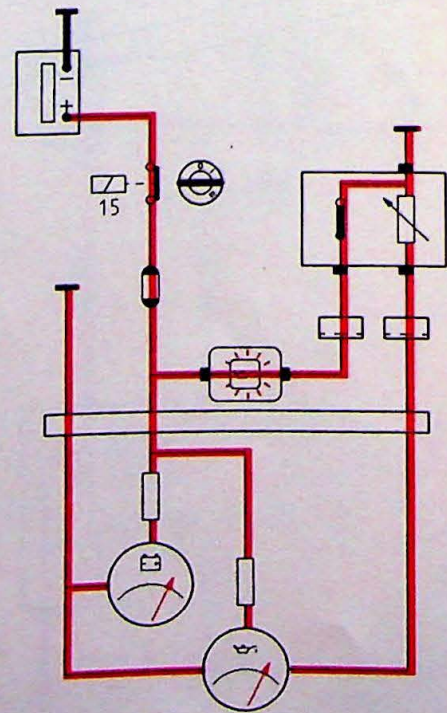
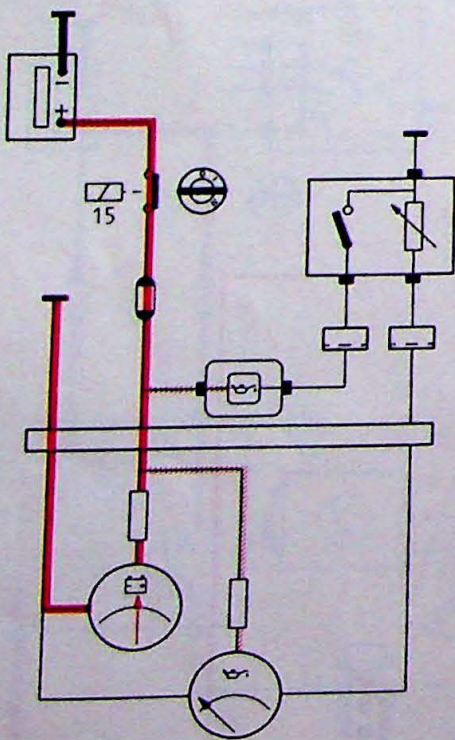

8-013/044

# Accuvolt- en oliedrukmeter

A48

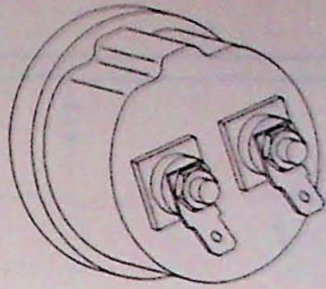

Y  
Br

C19

c19 → a3



4 = Y

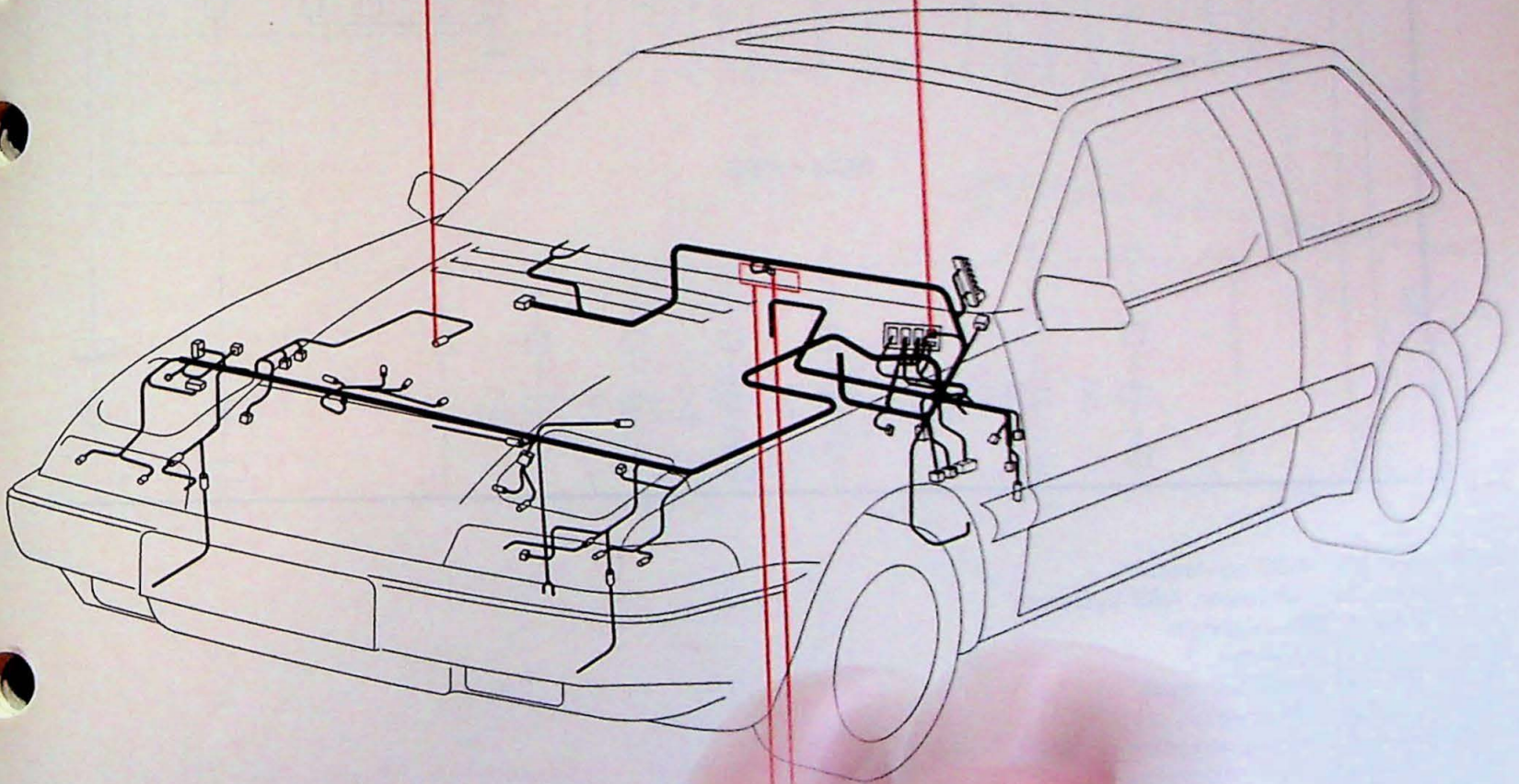

C32-C33

C23

# Centrale vergrendeling

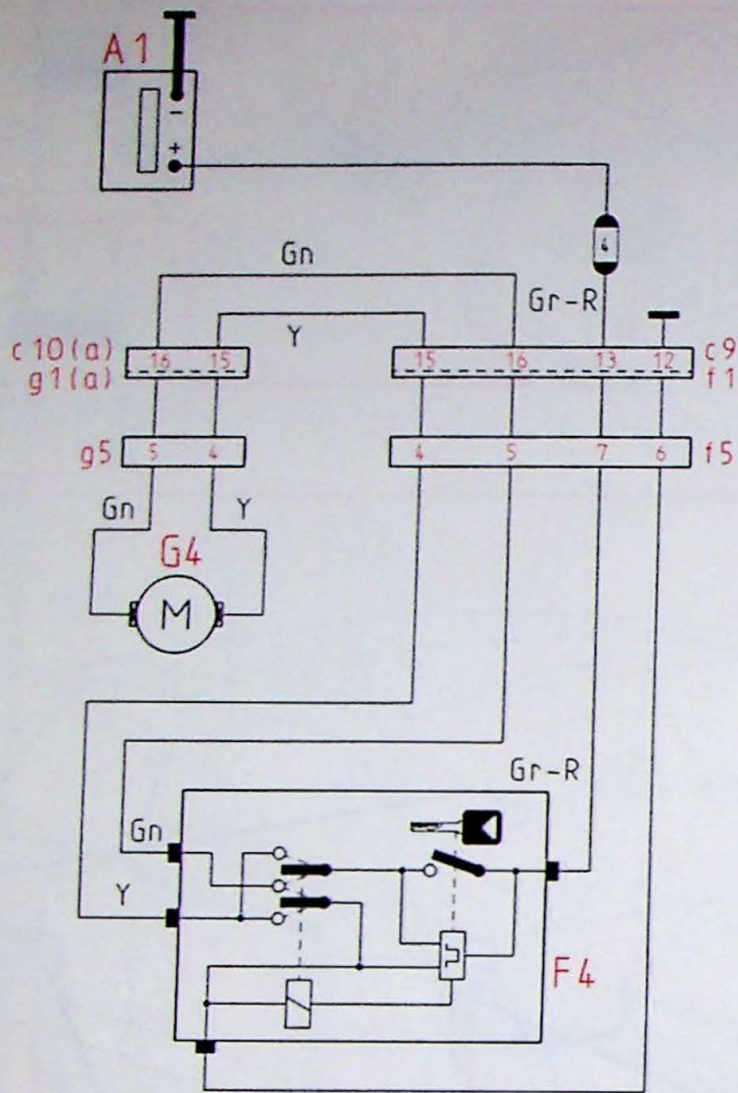

F4 Schakelaar, centrale vergrendeling  
 G4 Motor, centrale vergrendeling

Portier op slot

Portieren worden vergrendeld (met sleutel of met knop, bestuurdersportier)

Portieren worden ontgrendeld (met sleutel of met deurklink, bestuurdersportier)

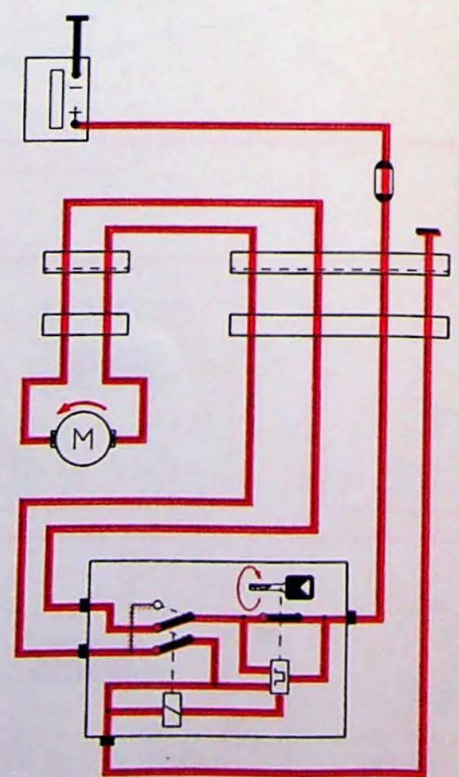
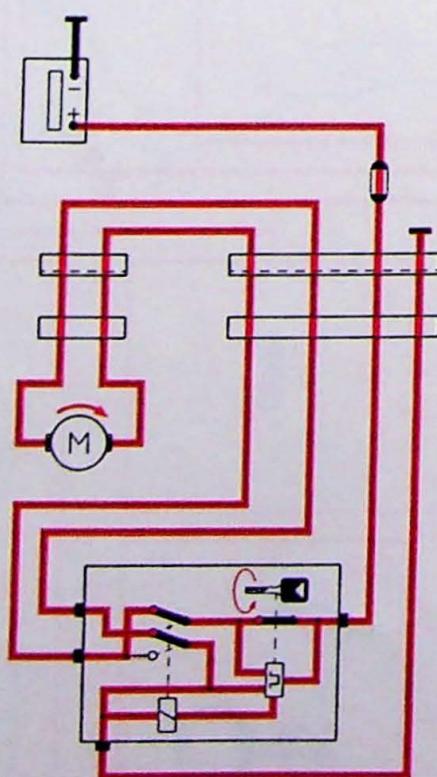
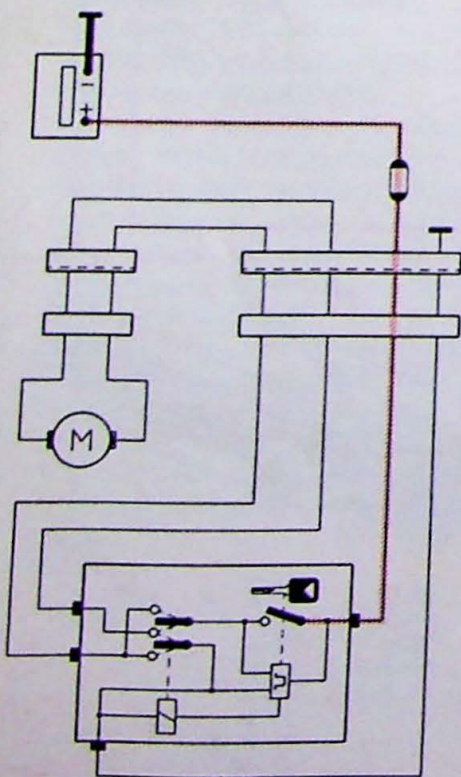

8-013/028

# Centrale vergrendeling

c 10 (a)

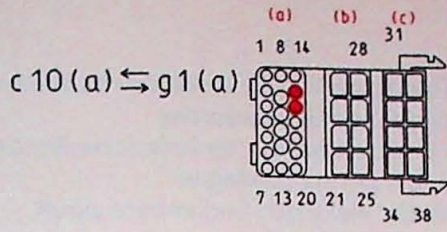

15=Y  
16=Gn

G4

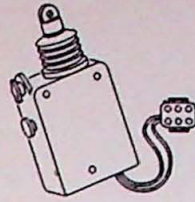

Gn  
Y

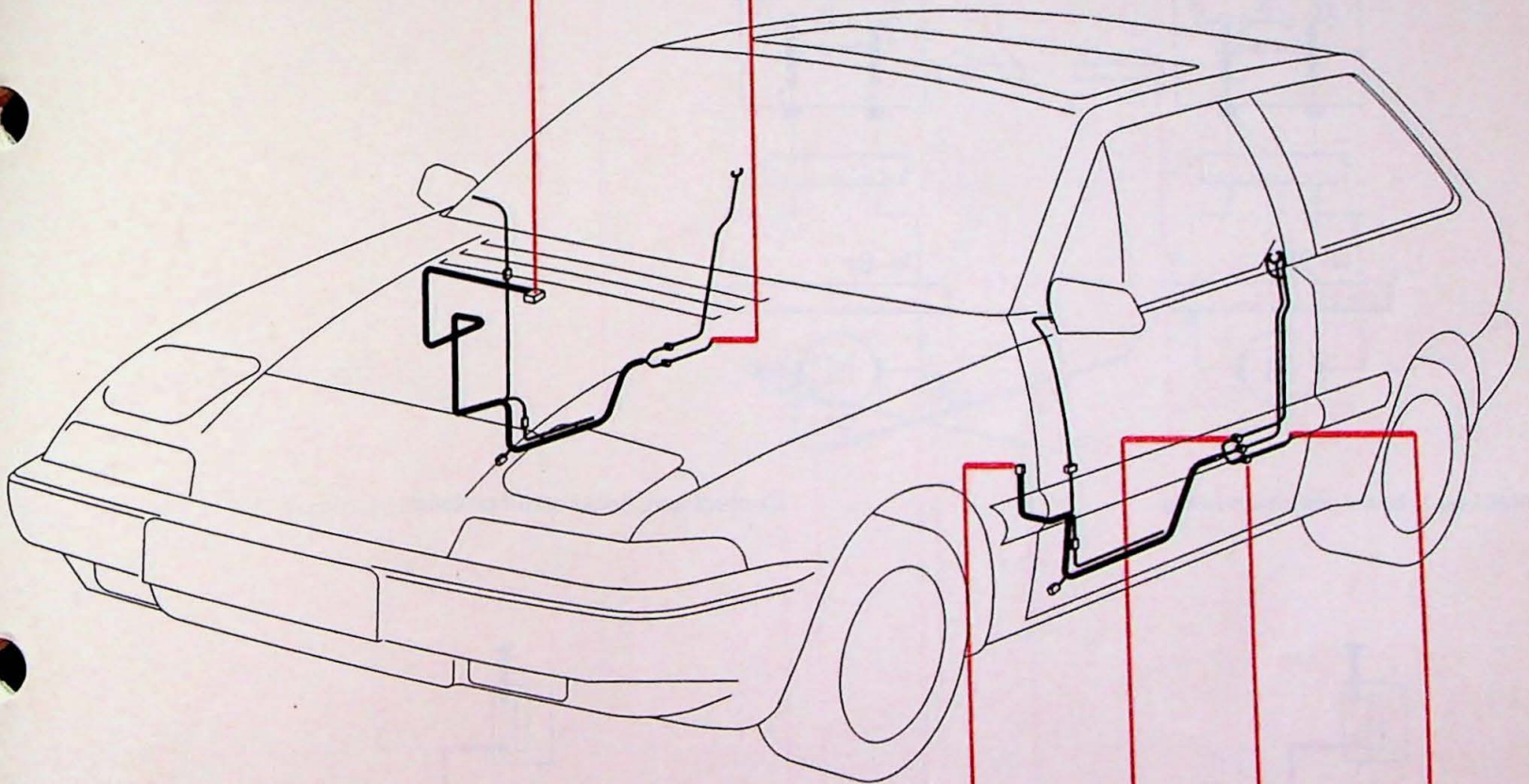

c 9

c 9 ↔ f 1

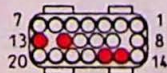

12=Br  
13=Gr-R  
15=Y  
16=Gn

f 6

f 6



1 = Br  
2 = Gr-R

f 5

f 5



4 = Y  
5 = Gn  
6 = Br  
7 = Gr-R

F 4

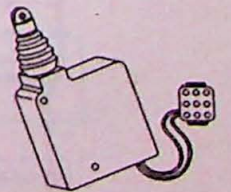

Y  
Gn  
Br  
Gr-R

# Elektrisch bedienbare zijruiten

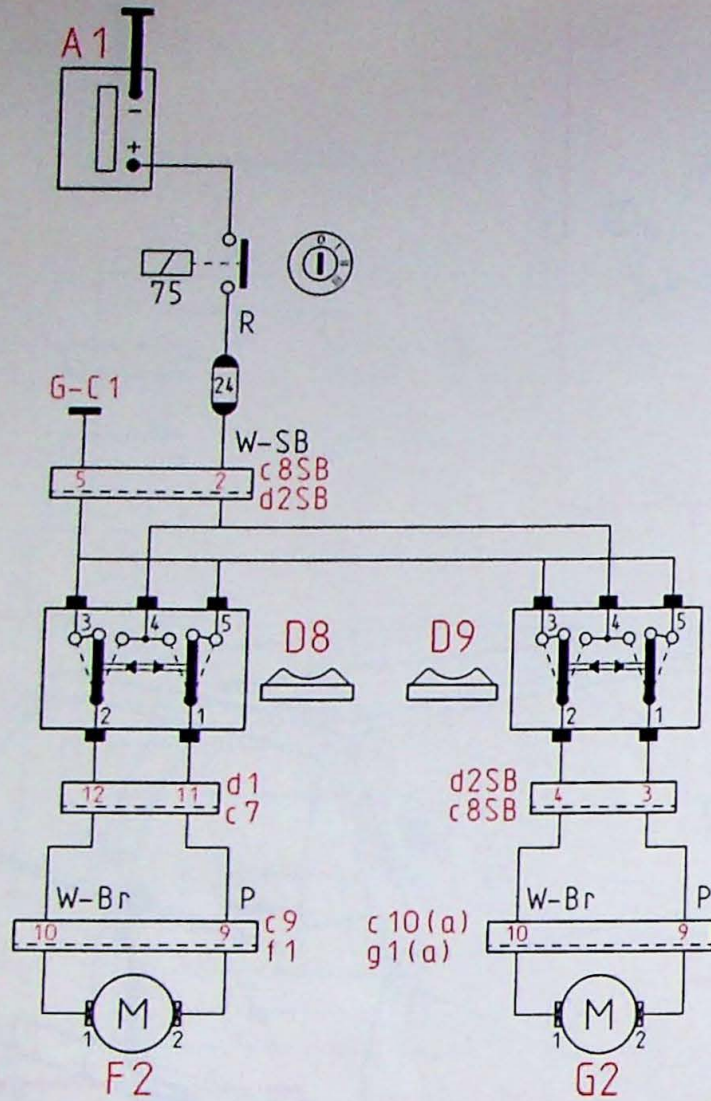

- D8 Tuimelschakelaar, elektrisch bedienbare zijruit, portier bestuurder
- D9 Tuimelschakelaar, elektrisch bedienbare zijruit, portier passagier
- F2 Motor, elektrisch bedienbare zijruit, portier bestuurder
- G2 Motor, elektrisch bedienbare zijruit, portier passagier

Contact aan, linker zijruit omhoog

Contact aan, linker zijruit omlaag

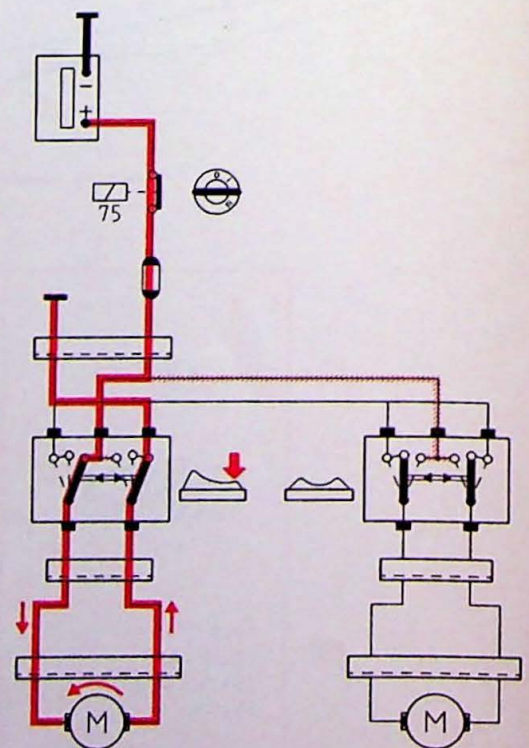
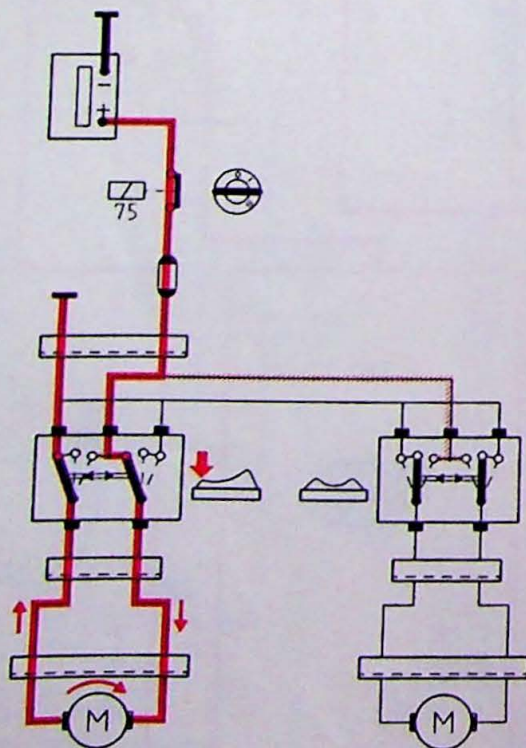

8-013/051

# Elektrisch bedienbare zijruiten

c 10 (a)

c 10 (a)  $\leftrightarrow$  g 1 (a)

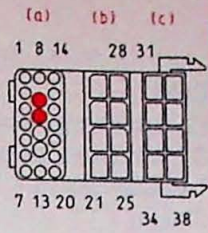

9 = P  
10 = W-Br

F2 - G2

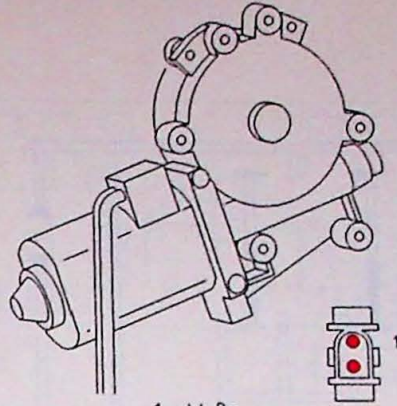

1 = W-Br  
2 = P

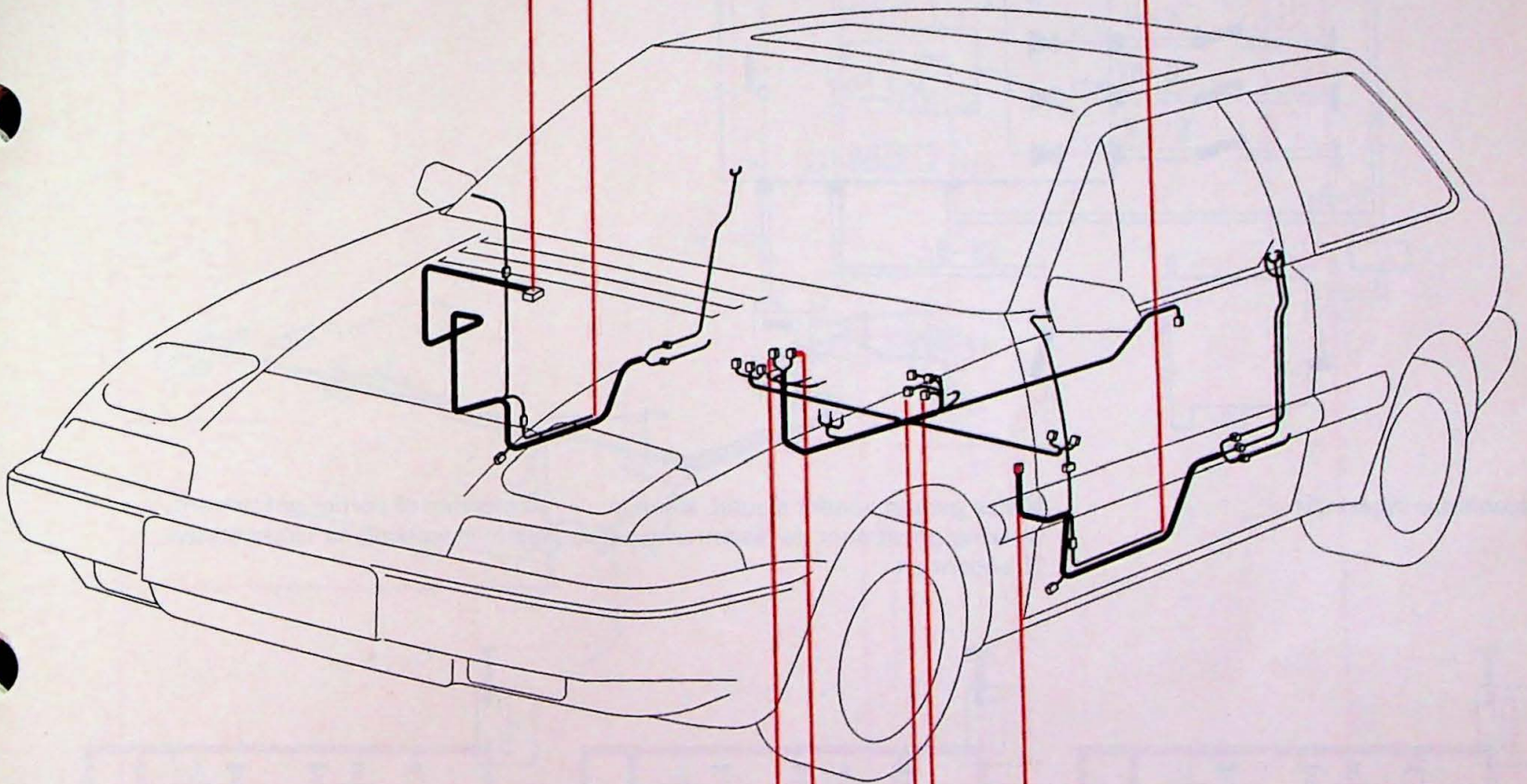

c 7

c 7  $\leftrightarrow$  d 1

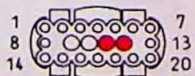

11 = P  
12 = W-Br

c 8 SB

c 8 SB  $\leftrightarrow$  d 2 SB



2 = W-SB  
3 = P  
4 = W-Br  
5 = Br

D 8, D 9

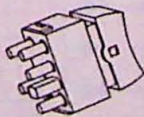

1 = P  
2 = W-Br  
3 = Br  
4 = W-SB  
5 = Br

c 9

c 9  $\leftrightarrow$  f 1

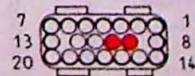

9 = P  
10 = W-Br

# Inbraakalarmsysteem en claxon

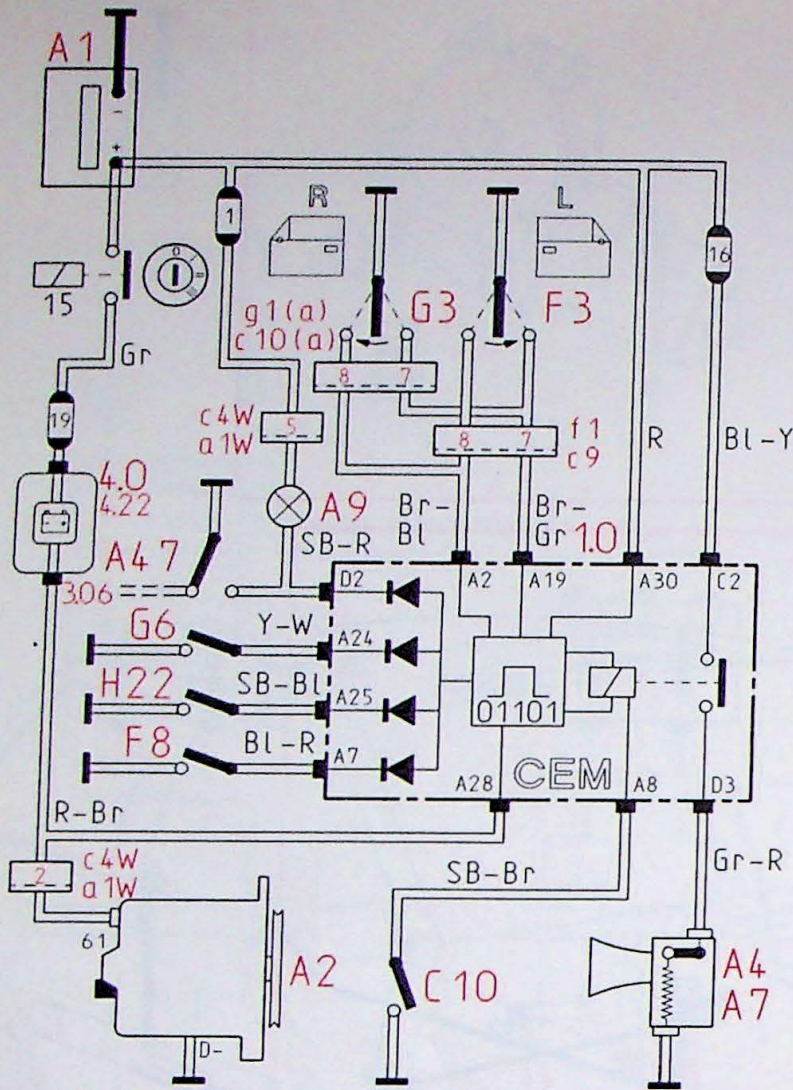

- 1.0 CEM
- 4.22 Controlelamp, laadstroom
- A2 Dynamo en spanningsregelaar
- A4 Tweede claxon
- A7 Claxon
- A9 Motorruimteverlichting
- A47 Schakelaar, motorkapslot
- C10 Schakelaar claxon
- F3 Portierslotschakelaar, portier bestuurder
- G3 Portierslotschakelaar, portier passagier
- F8 Deurschakelaar, portier bestuurder
- G6 Deurschakelaar, portier passagier
- H22 Schakelaar achterklepslot

Claxonknop ingedrukt

Motor gestart zonder sleutel, alarm in werking gezet door de laadstroom na 15 seconden

Achterklep of portier geforceerd, alarm in werking na 15 seconden

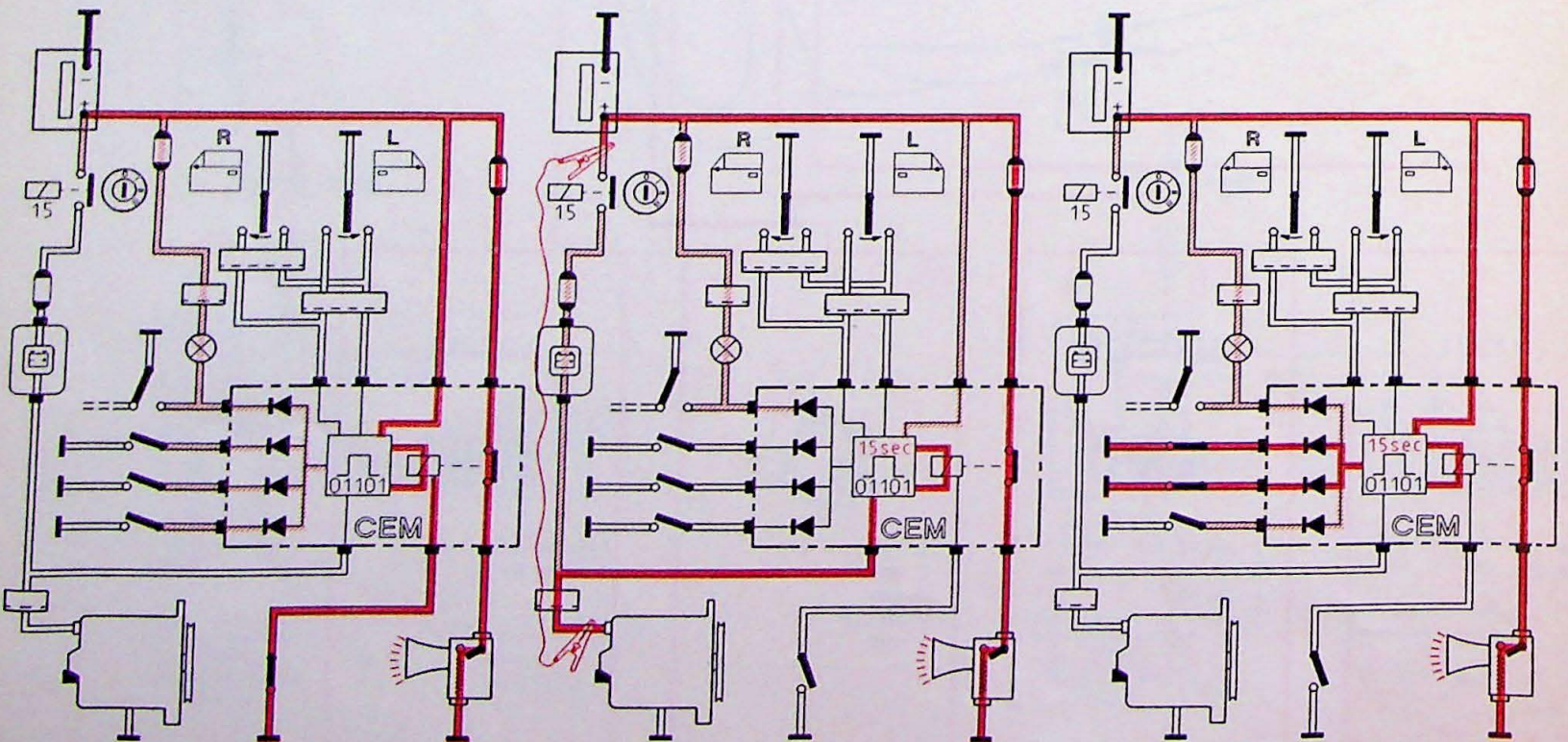

8-013/007

# Inbraakalarmsysteem en claxon

A2

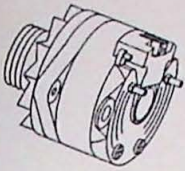

c 10 (a)

c 10 (a) ↔ g1 (a)

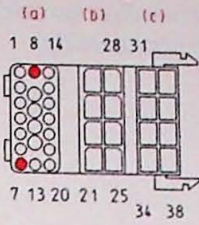

7 = Br-Gr  
8 = Br-Bl

4.0

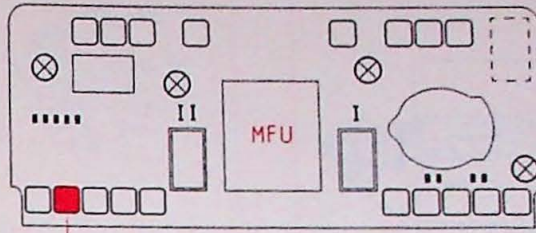

F3, G3, H22

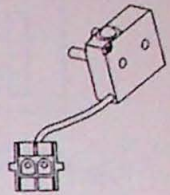

Br-Bl  
Br-Gr

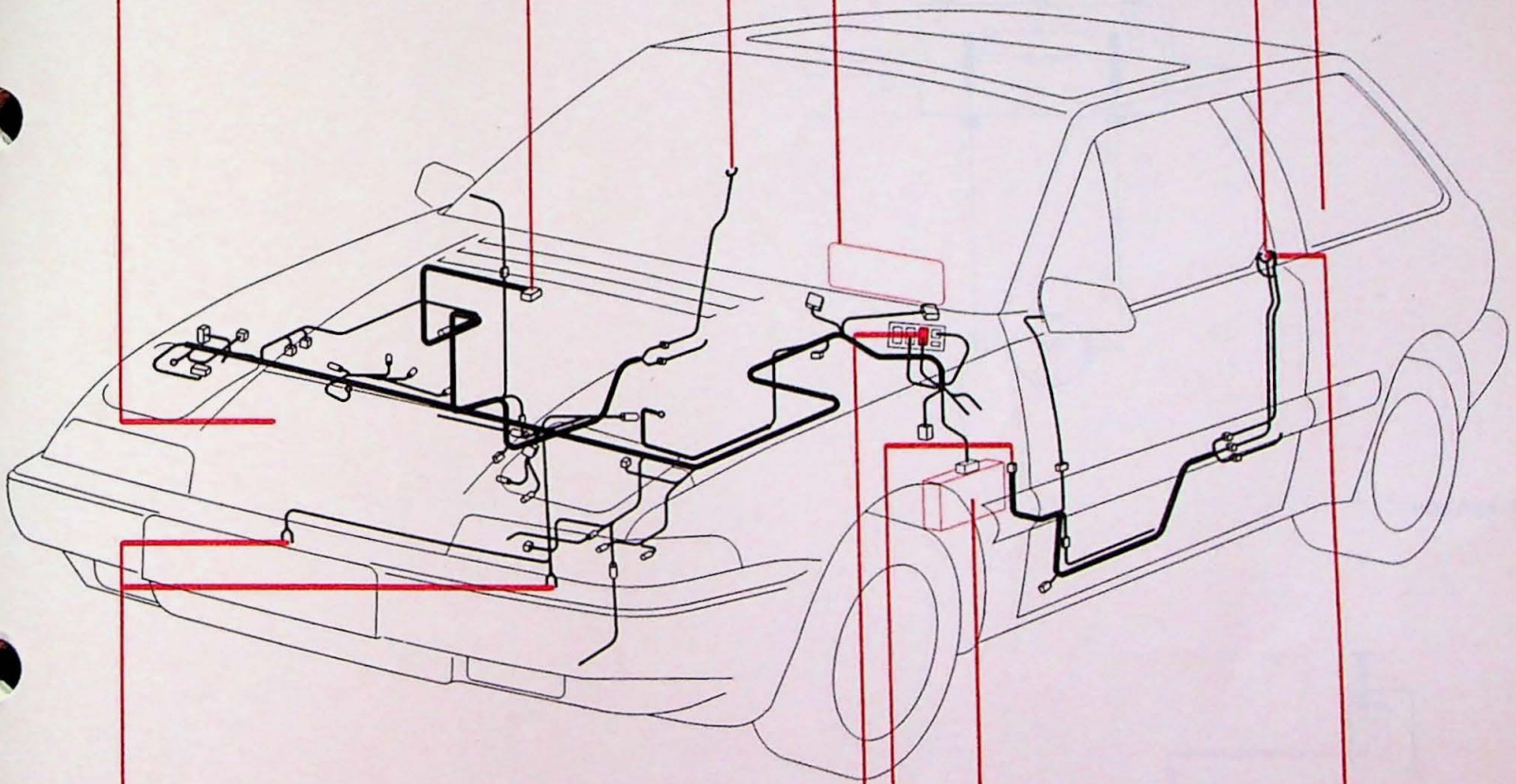

A4, A7

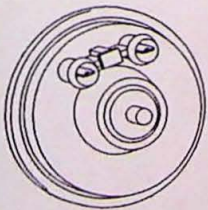

Gr-R  
Br

c 4W

c 4W ↔ a 1W

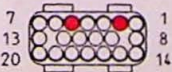

2 = R-Br  
5 = R-Br

1.0

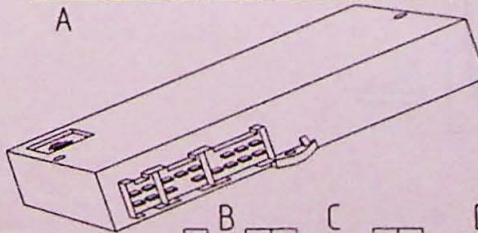
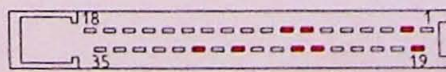

A2 = Br-Gr  
A7 = Bl-R  
A8 = SB-Br  
A19 = Br-Bl  
A24 = Y-W  
A25 = SB-Bl  
A28 = R-Br  
A30 = R  
C2 = Bl-Y  
D3 = Gr-R  
D2 = SB-R

F8, G6

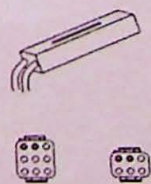

# Kanteldak

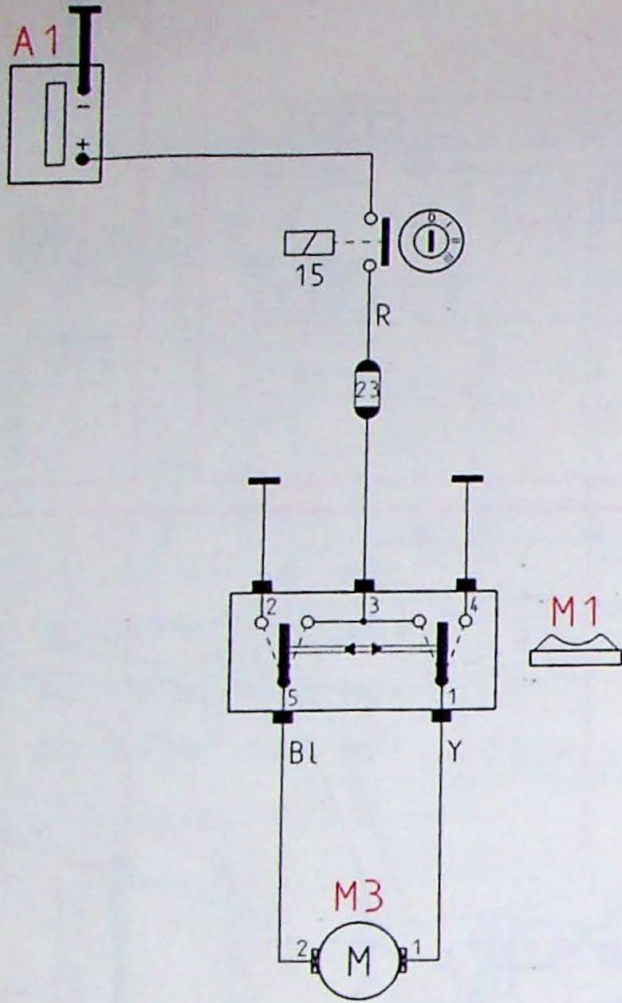

- M1 Schakelaar kanteldak
- M3 Motor kanteldak

## Dak kantelen

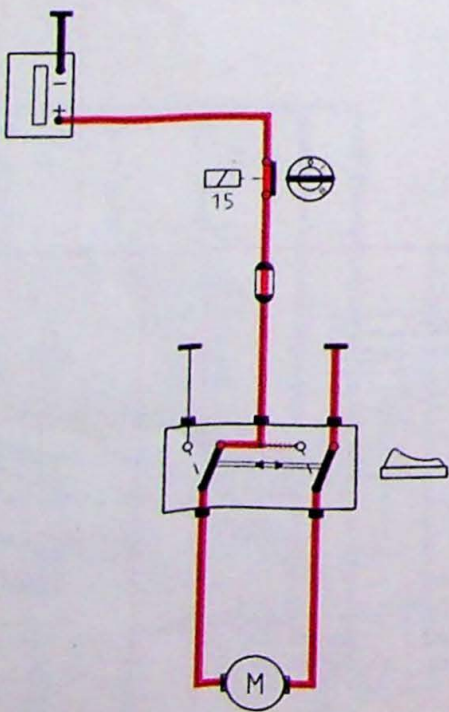

8-013/080

M1

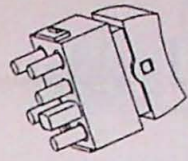

- 1 = Y
- 2 = Br
- 3 = R
- 4 = Br
- 5 = Bl

M3

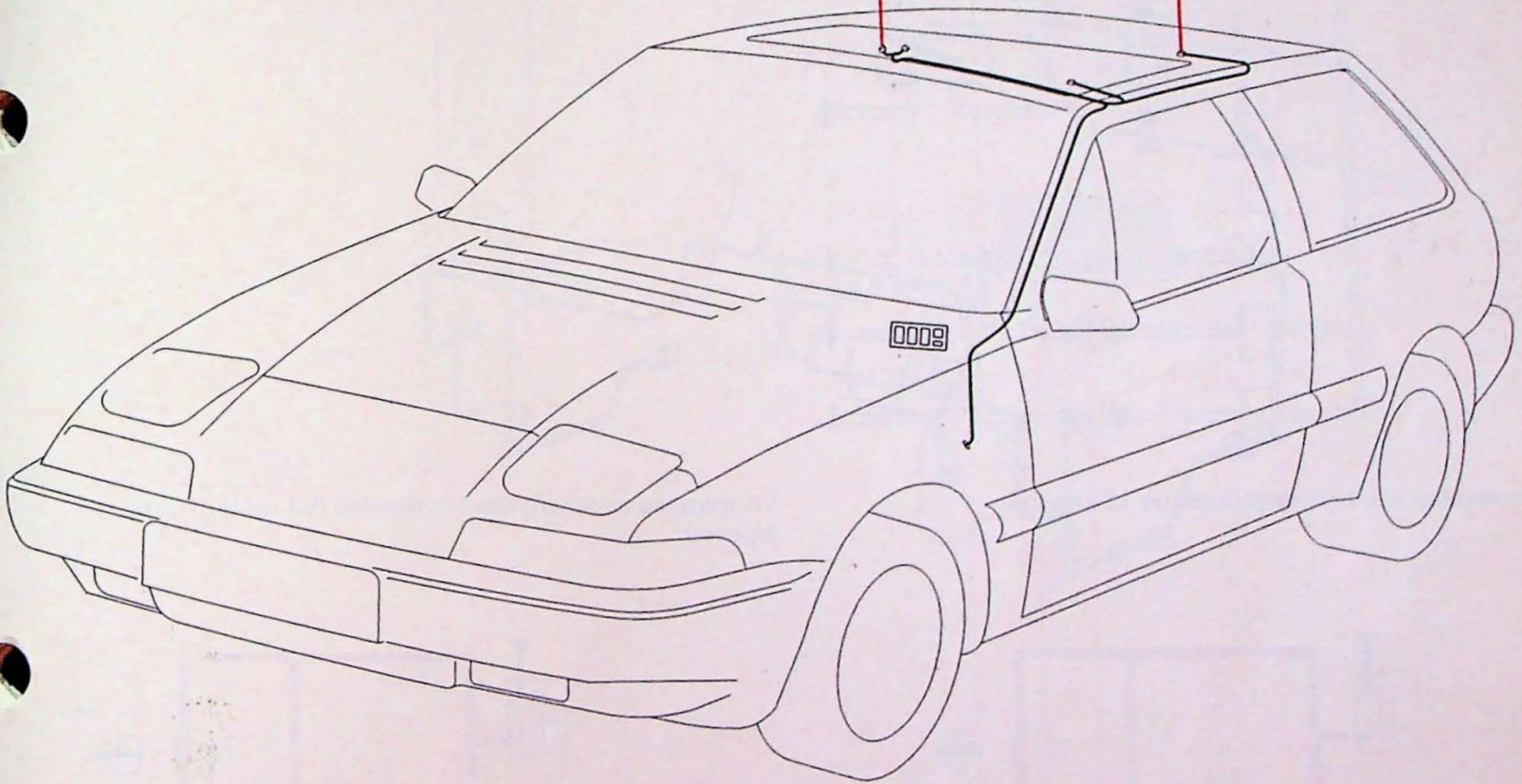
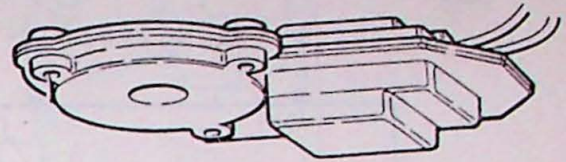

# Achterraut- en spiegelverwarming

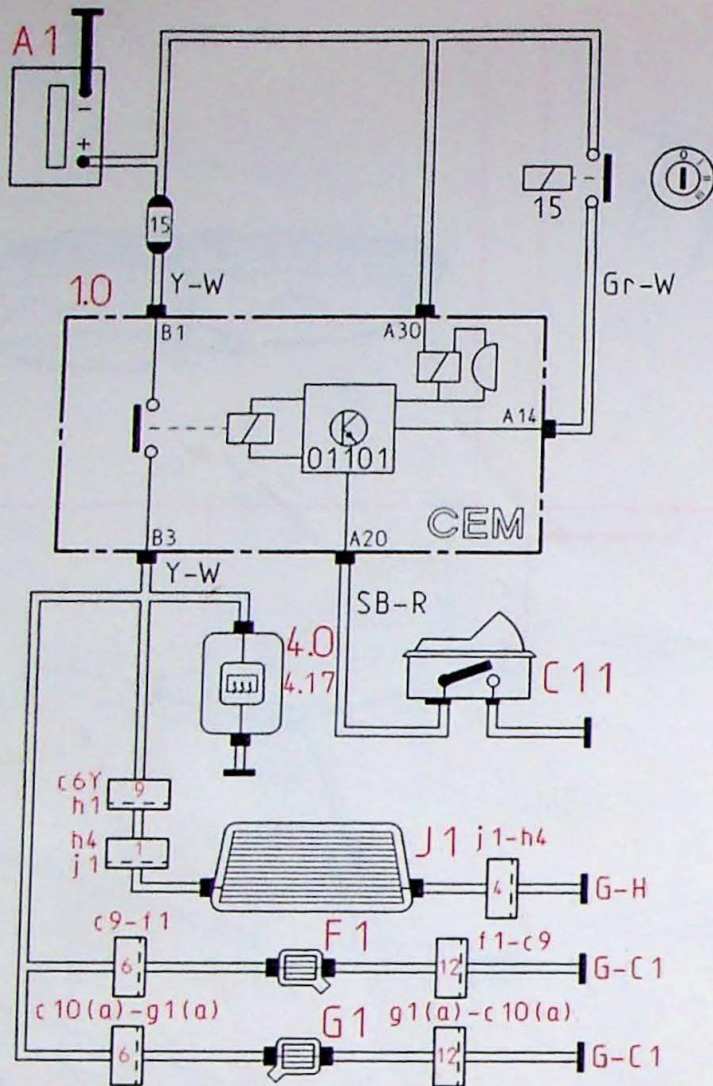

- 1.0 CEM
- 4.17 Controlelamp, achterrautverwarming
- C11 Schakelaar achterrautverwarming
- F1 Verwarmingselement, achteruitkijkspiegel bestuurderszijde
- G1 Verwarmingselement, achteruitkijkspiegel passagierszijde
- J1 Verwarmingselement, achterraut

Verwarming in werking gedurende 12 minuten

Verwarming ononderbroken in werking (tot motor wordt afgezet)

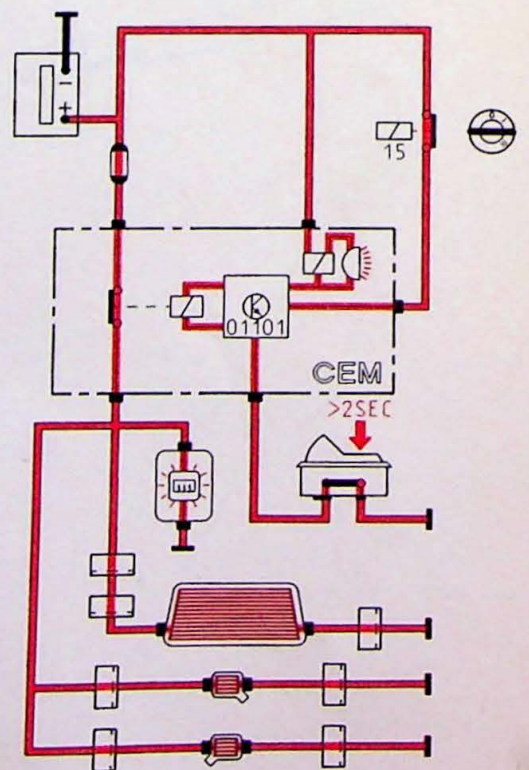
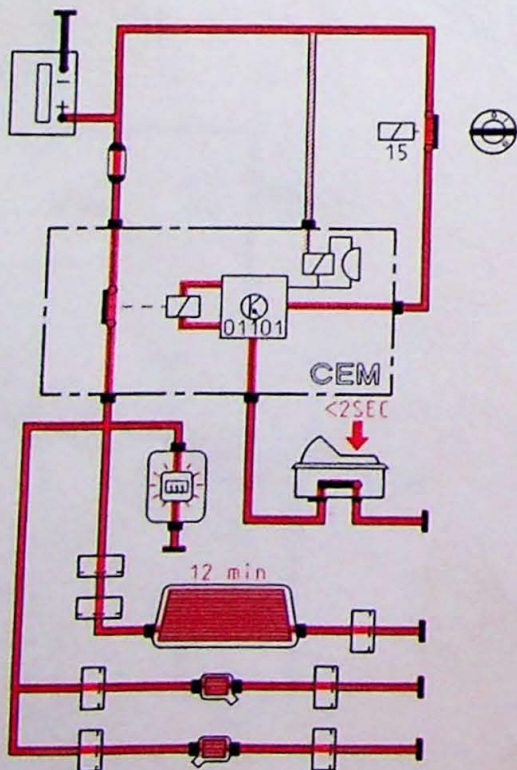

8-013/053

# Achterrait- en spiegelverwarming

G1

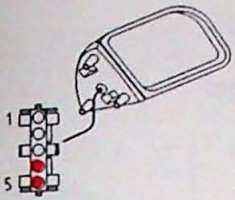

4 = Y-W  
5 = Br

c 10 (a)

c 10 (a) ↔ g1 (a)

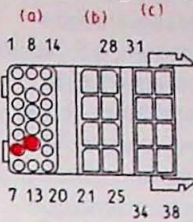

6 = Y-W  
12 = Br

c6Y

c6Y ↔ h1Y

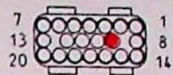

9 = Y-W

C11

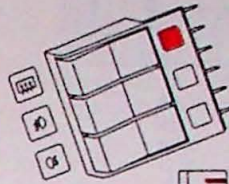

30 = SB-R  
31 = Br

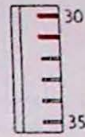

h4

h4 ↔ j1



1 = Y-W  
4 = Br

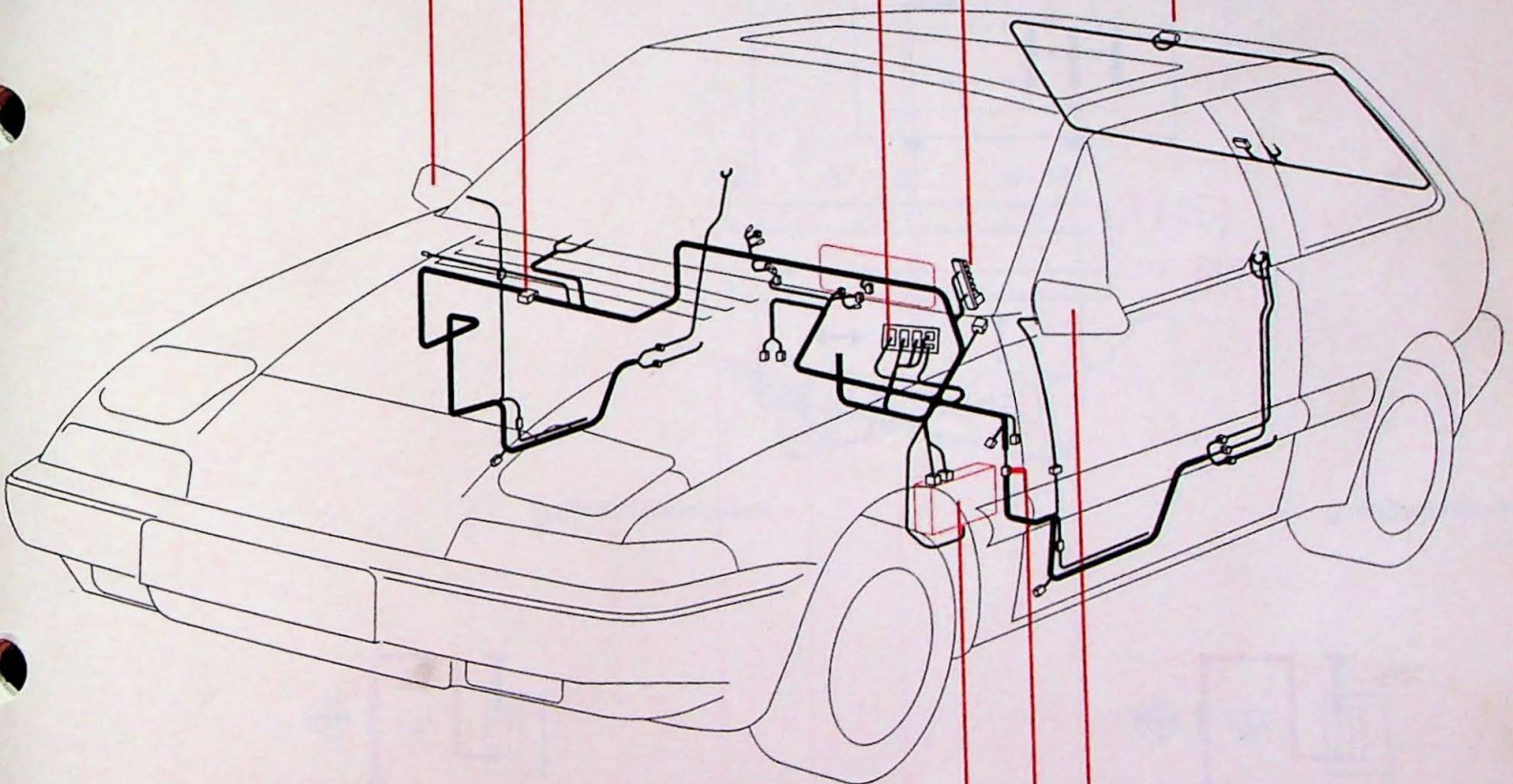

1.0

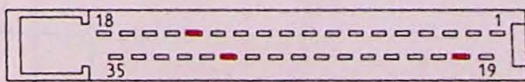

A

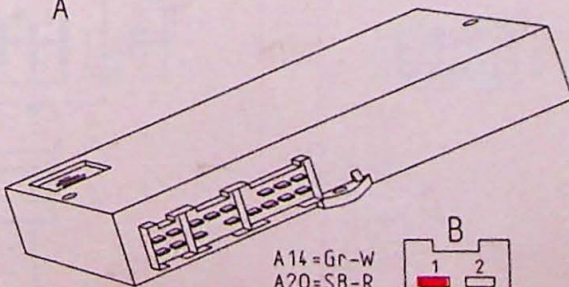

B

A14 = Gr-W  
A20 = SB-R  
A30 = R  
B1 = Y-W  
B3 = Y-W

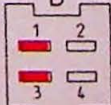

c9

c9 ↔ f1



6 = Y-W  
12 = Br

F1

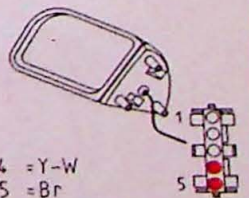

4 = Y-W  
5 = Br

# Elektrisch instelbare spiegels

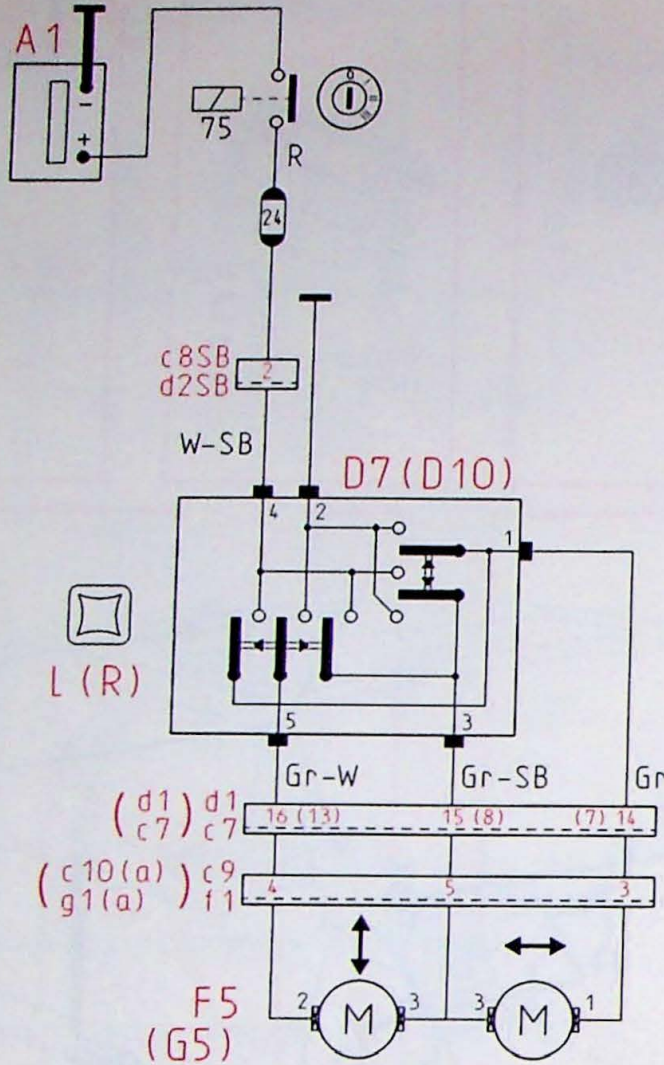

- D10 Instelknop, achteruitkijkspiegel passagierszijde
- G5 Motoren, achteruitkijkspiegel passagierszijde
- D7 Instelknop, achteruitkijkspiegel bestuurderszijde
- F5 Motoren, achteruitkijkspiegel bestuurderszijde

Verticale instelling

Horizontale instelling

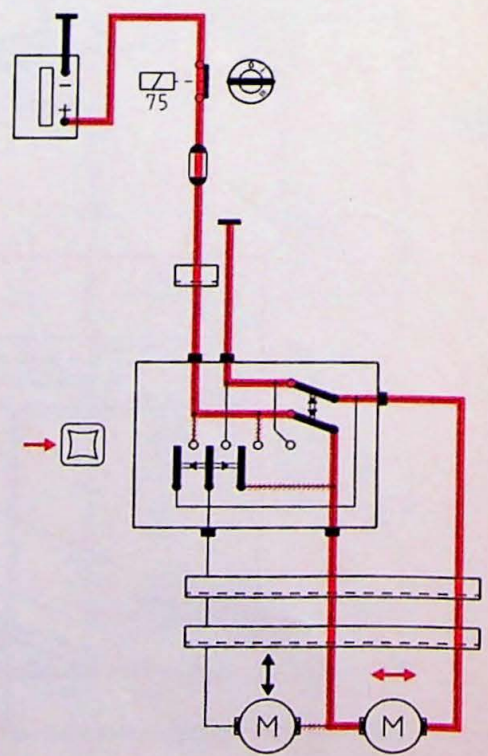
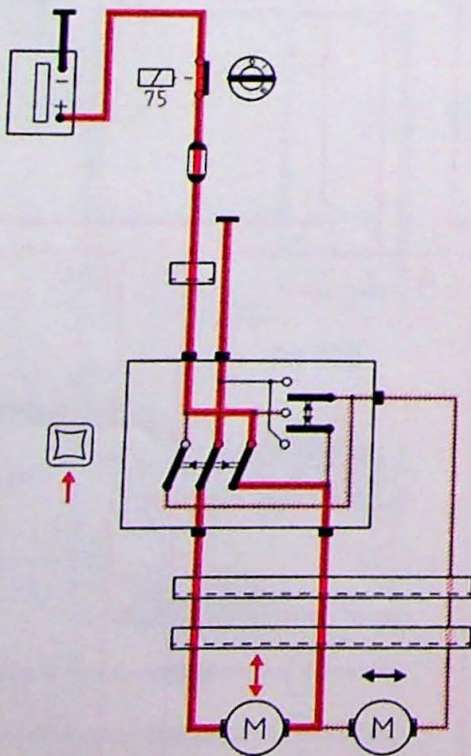

8-013/054

# Elektrisch instelbare spiegel

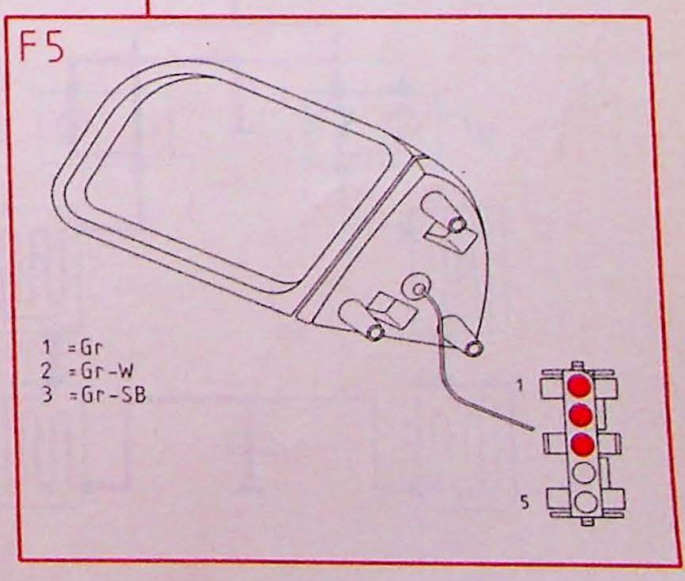
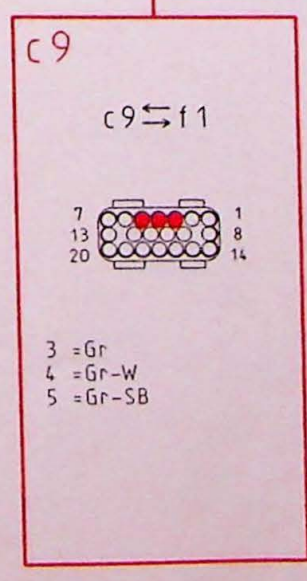
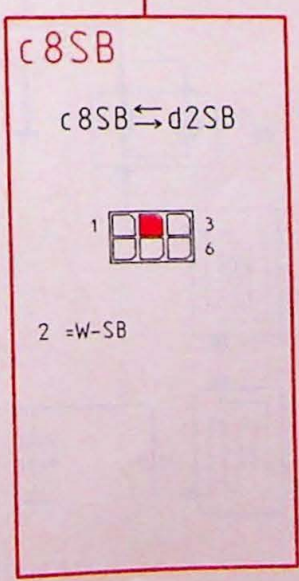
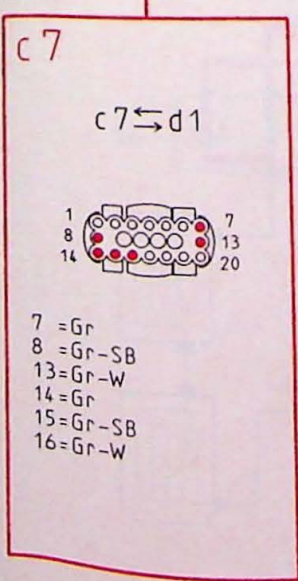
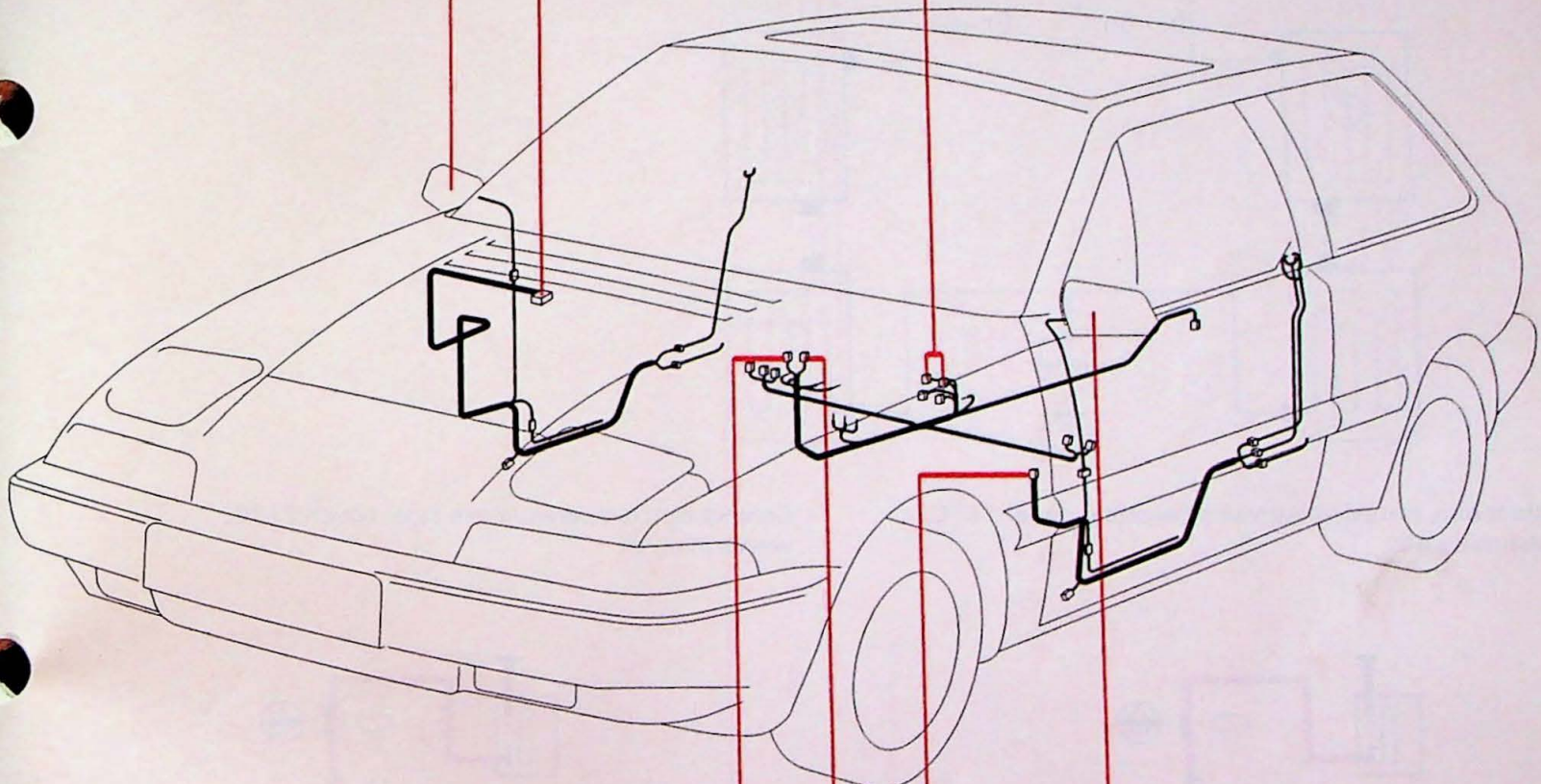
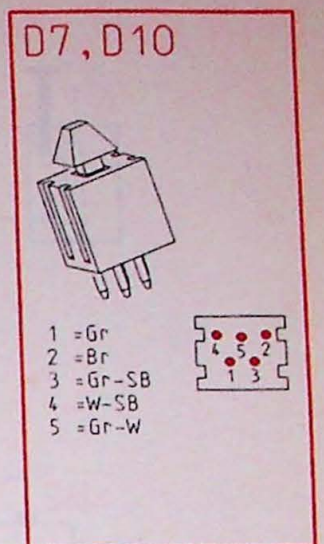
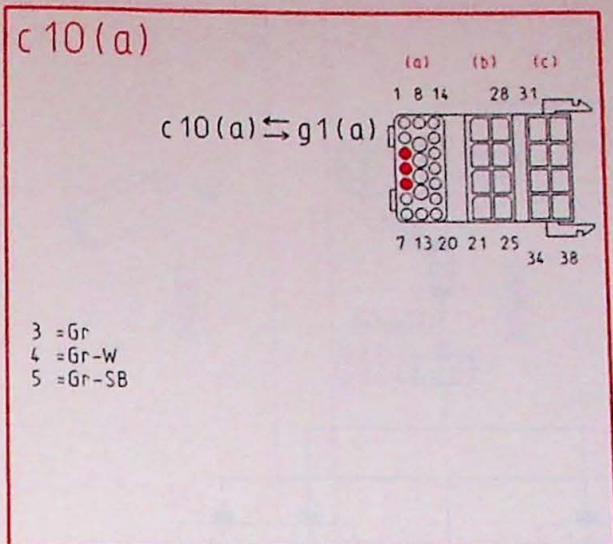
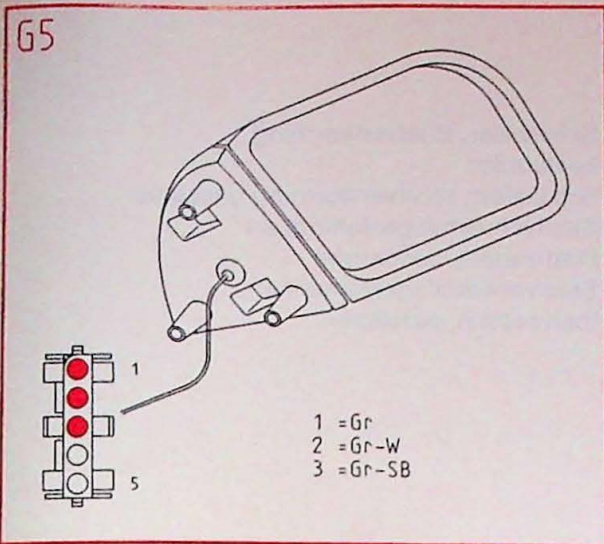

# Voorstoelverwarming

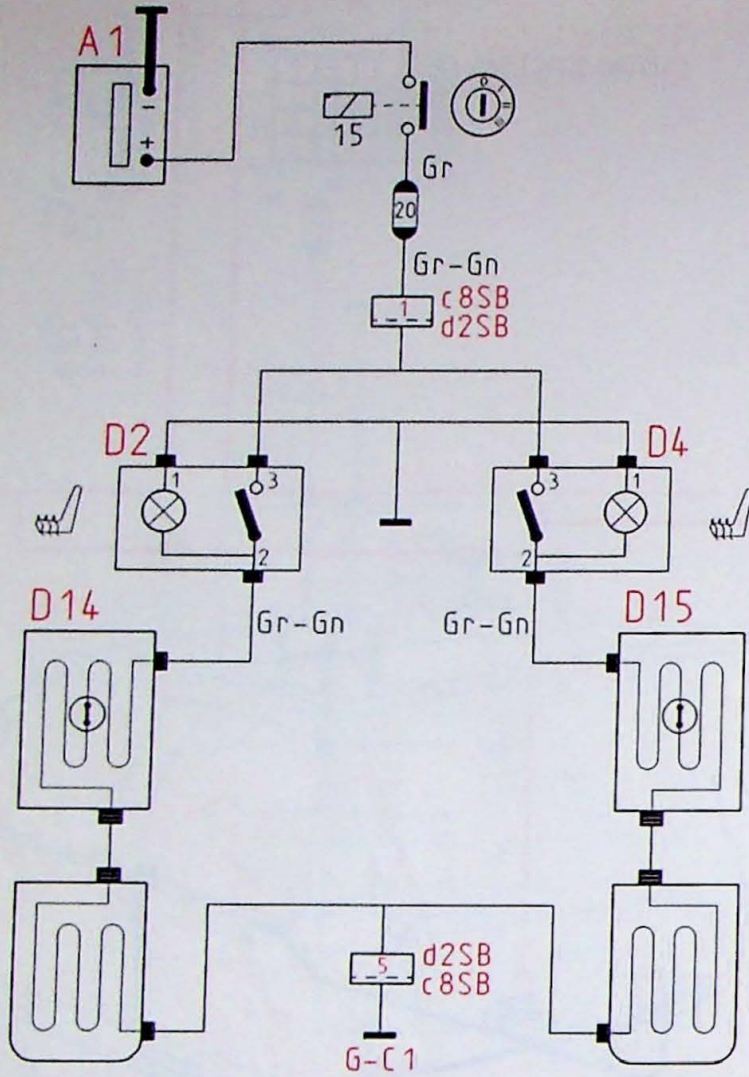

- D2 Schakelaar, stoelverwarming bestuurder
- D4 Schakelaar, stoelverwarming passagier
- D14 Stoelverwarmingselement en thermostaat, bestuurder
- D15 Stoelverwarmingselement en thermostaat, passagier

Contact aan, temperatuur van stoelzitting onder 14 °C, verwarming aan

Contact aan, temperatuur van stoel boven 27 °C, verwarming uit

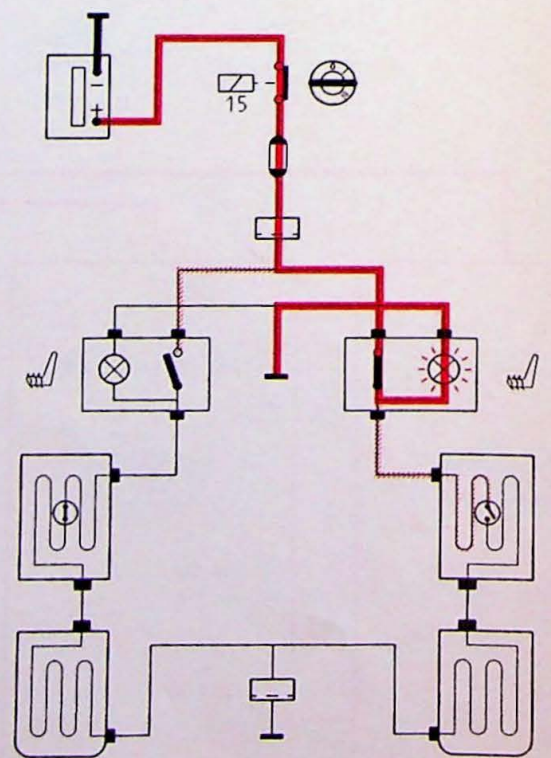
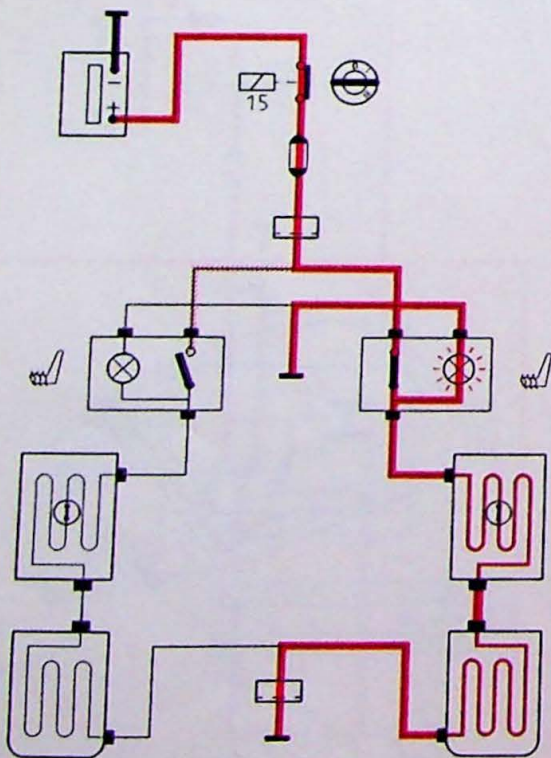

8-013/052

# Voorstoelverwarming

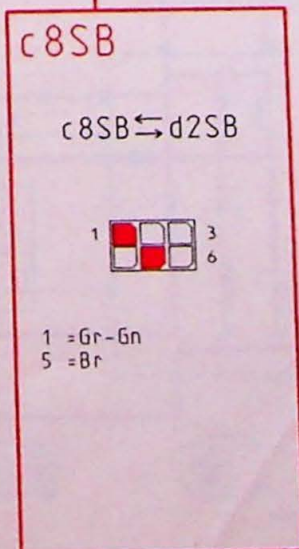
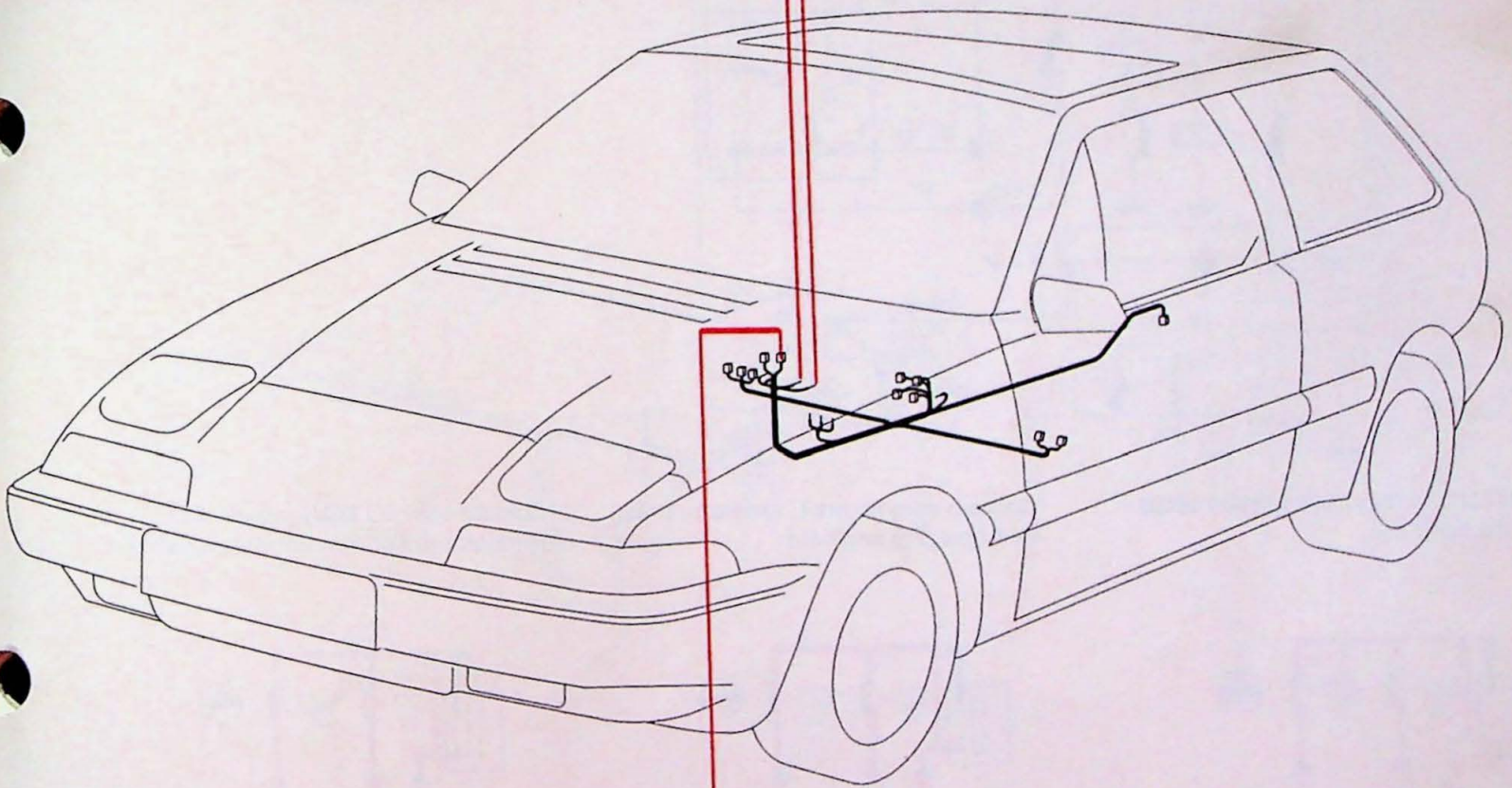
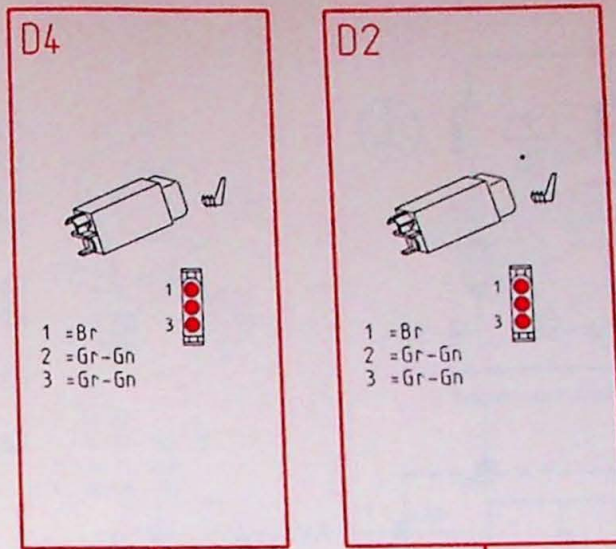

# Verwarming 4-standen

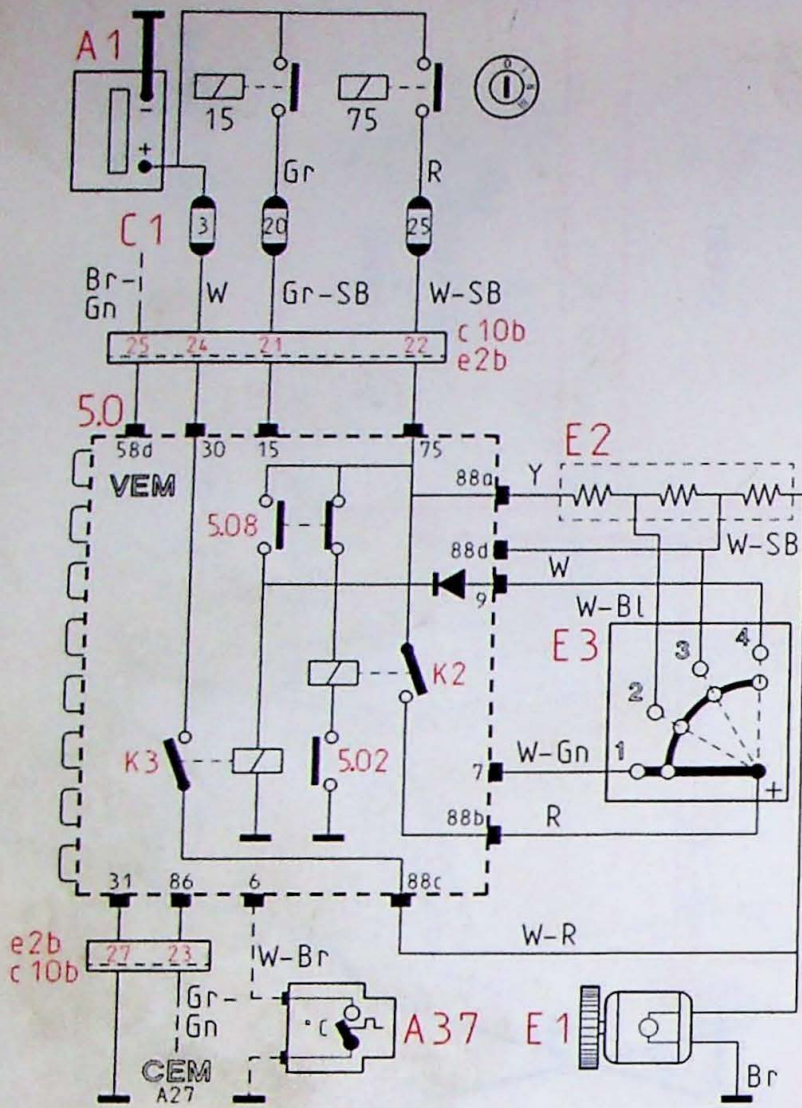

- 5.0 VEM
- 5.02 AAN/UIT schakelaar, verwarming
- 5.08 AC MAX schakelaar, airconditioning
- A37 Waterslang-temperatuurschakelaar (kachelventilator)
- E1 Motor, kachelventilator
- E2 Voorschakelweerstand, kachelventilator
- E3 Schakelaar, kachelventilator
  
- A37 tot chassisnummer 505600

Contact aan, ventilator draait altijd eerste snelheid

Contact aan, stand 4, ventilator draait met hoogste snelheid

Contact aan, AC MAX ingedrukt, ventilator draait met hoogste snelheid

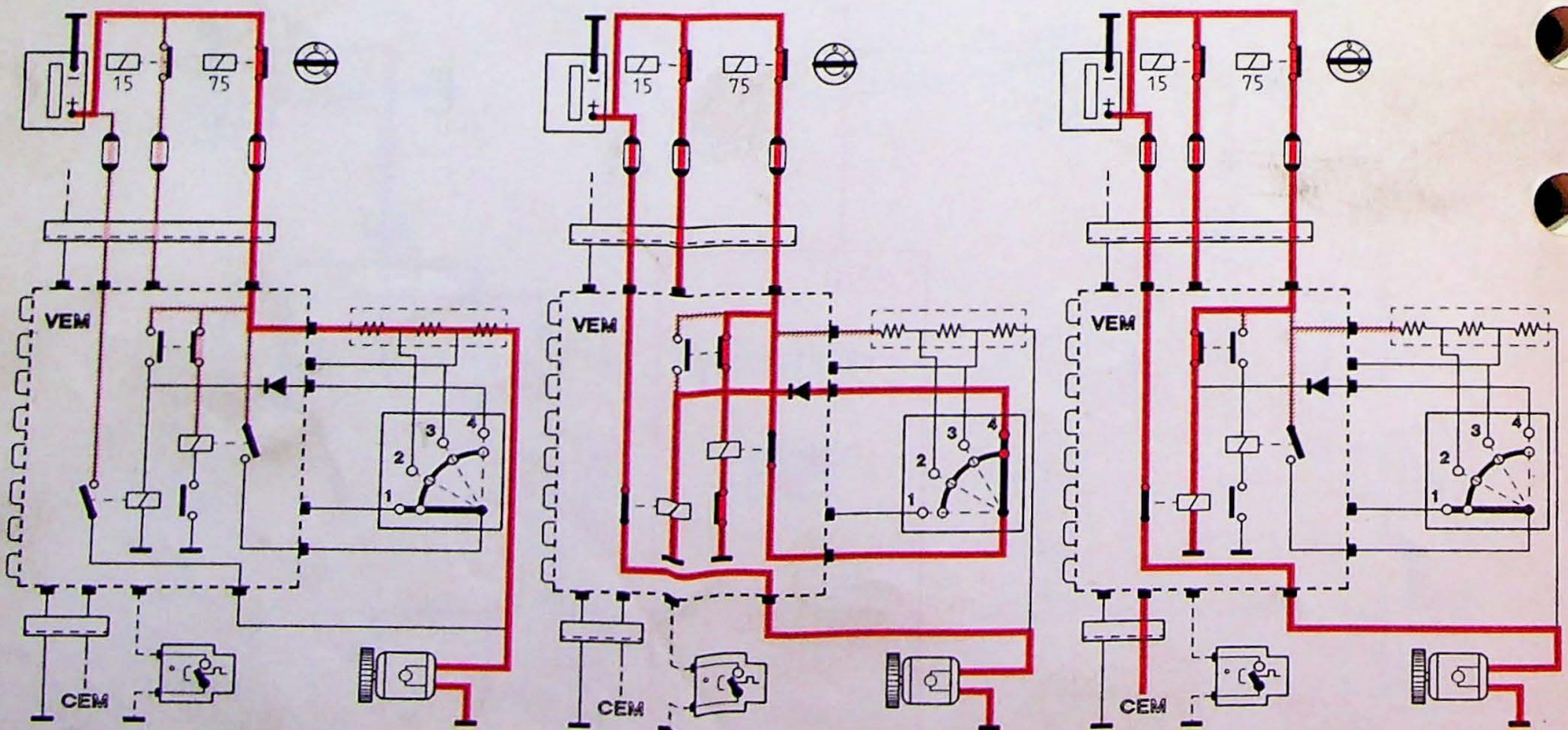

8-013/055

# Verwarming 4-standen

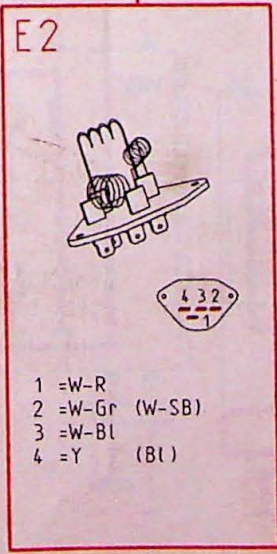
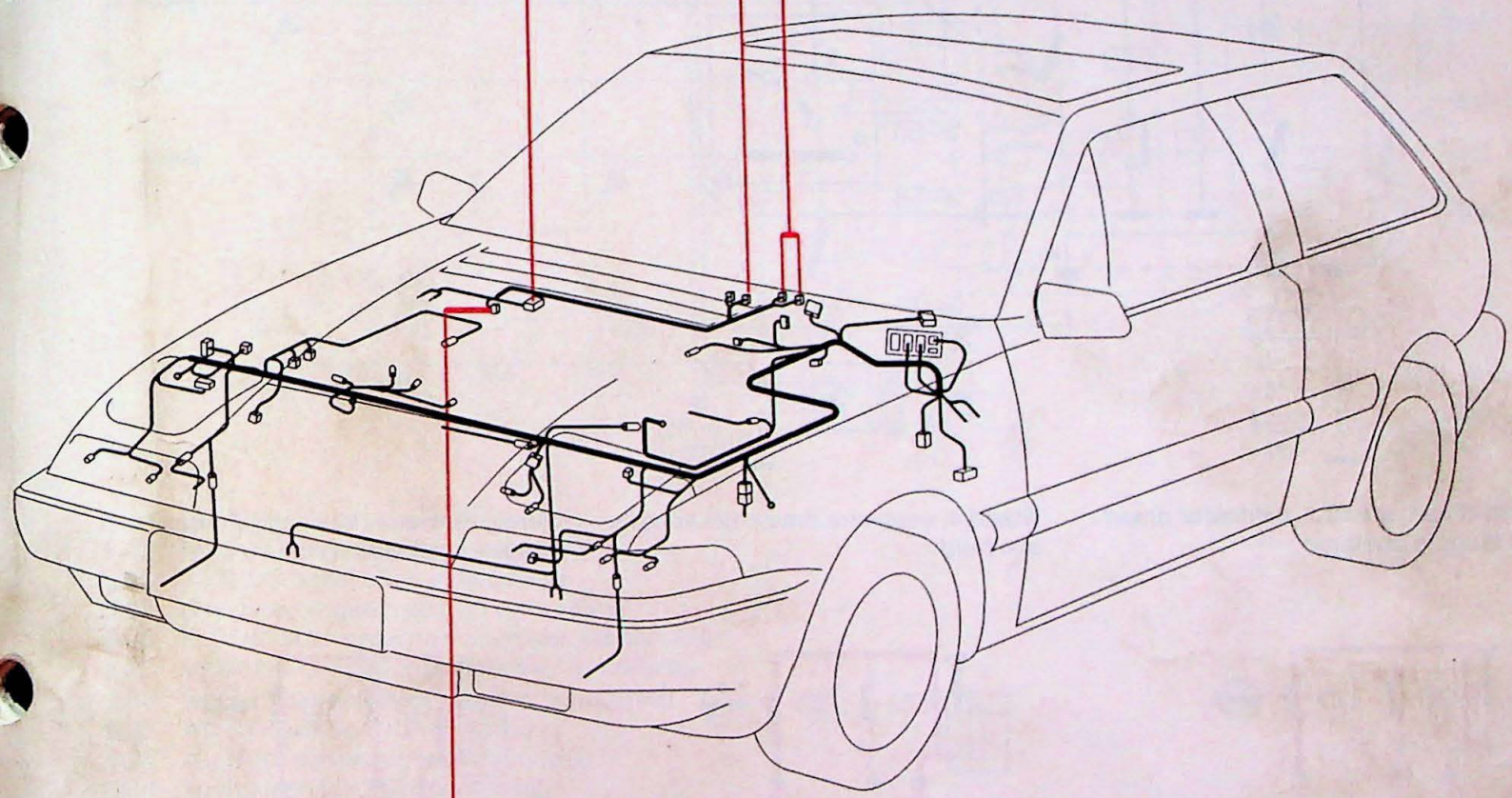
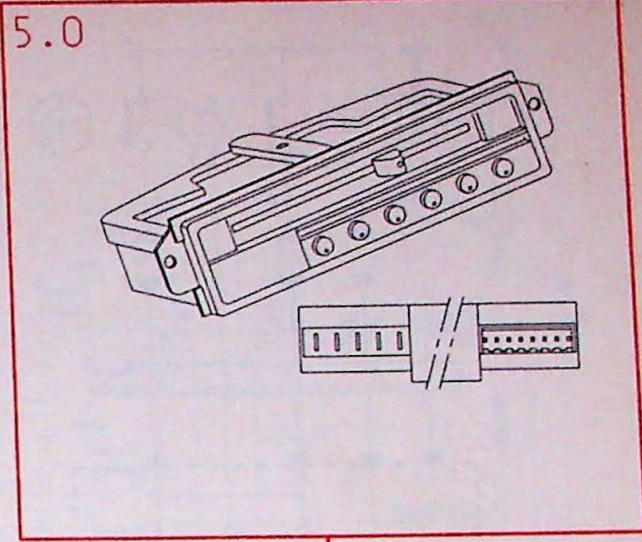
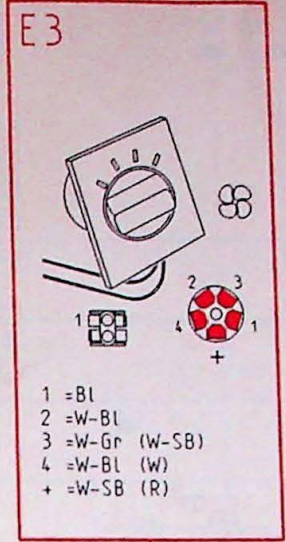
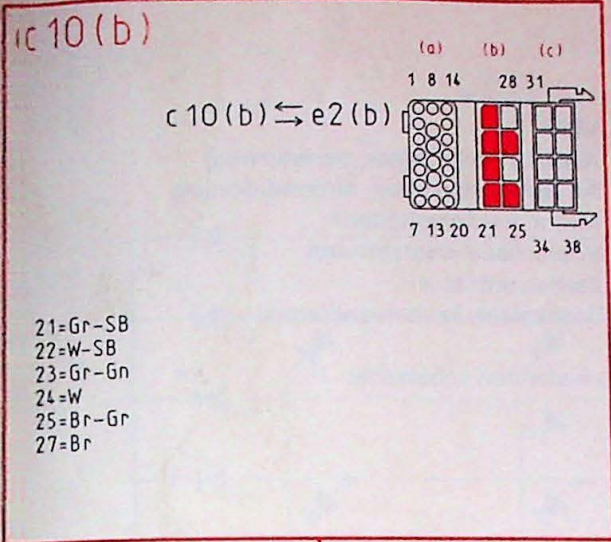

# Verwarming 5-standen, vanaf chnr. 513100

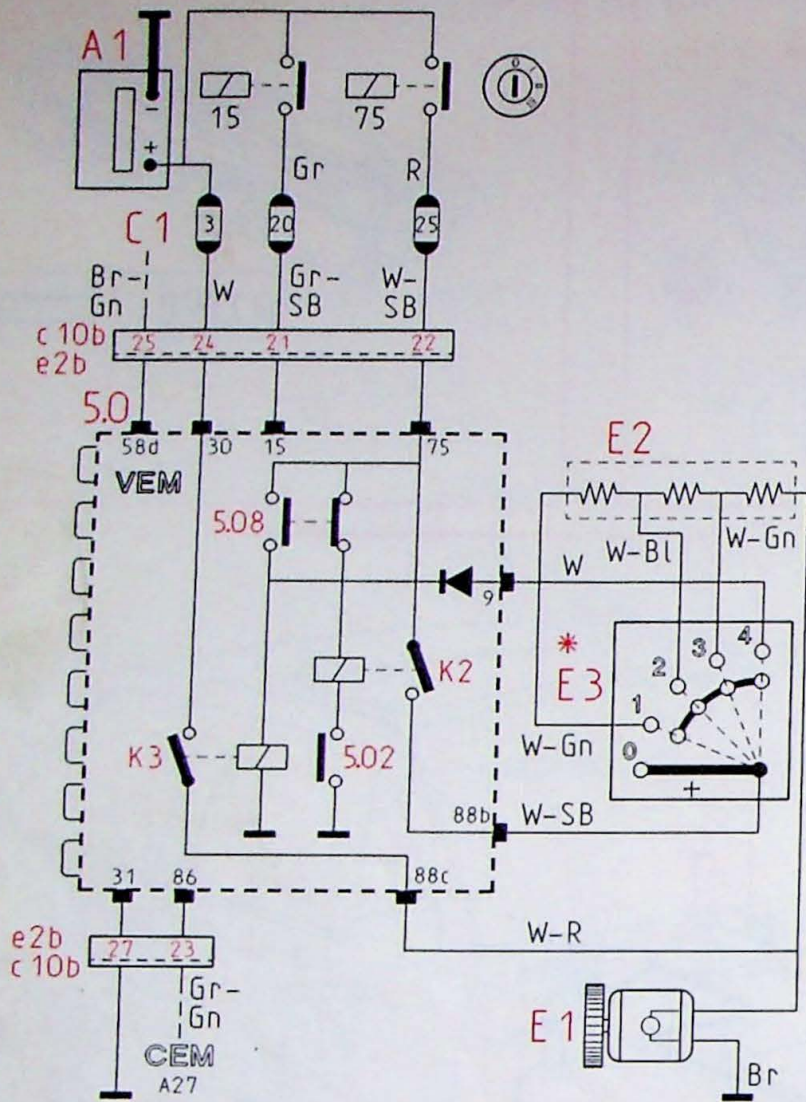

- 5.0 VEM
- 5.02 AAN/UIT schakelaar, verwarming
- 5.08 AC MAX schakelaar, airconditioning
- E1 Motor, kachelventilator
- E2 Voorschakelweerstand, kachelventilator
- E3 Schakelaar, kachelventilator

\* Airco 4-standen schakelaar

Contact aan, stand 1, ventilator draait met laagste snelheid

Stand 4, ventilator draait met hoogste snelheid

Airco, ventilator draait altijd met laagste snelheid

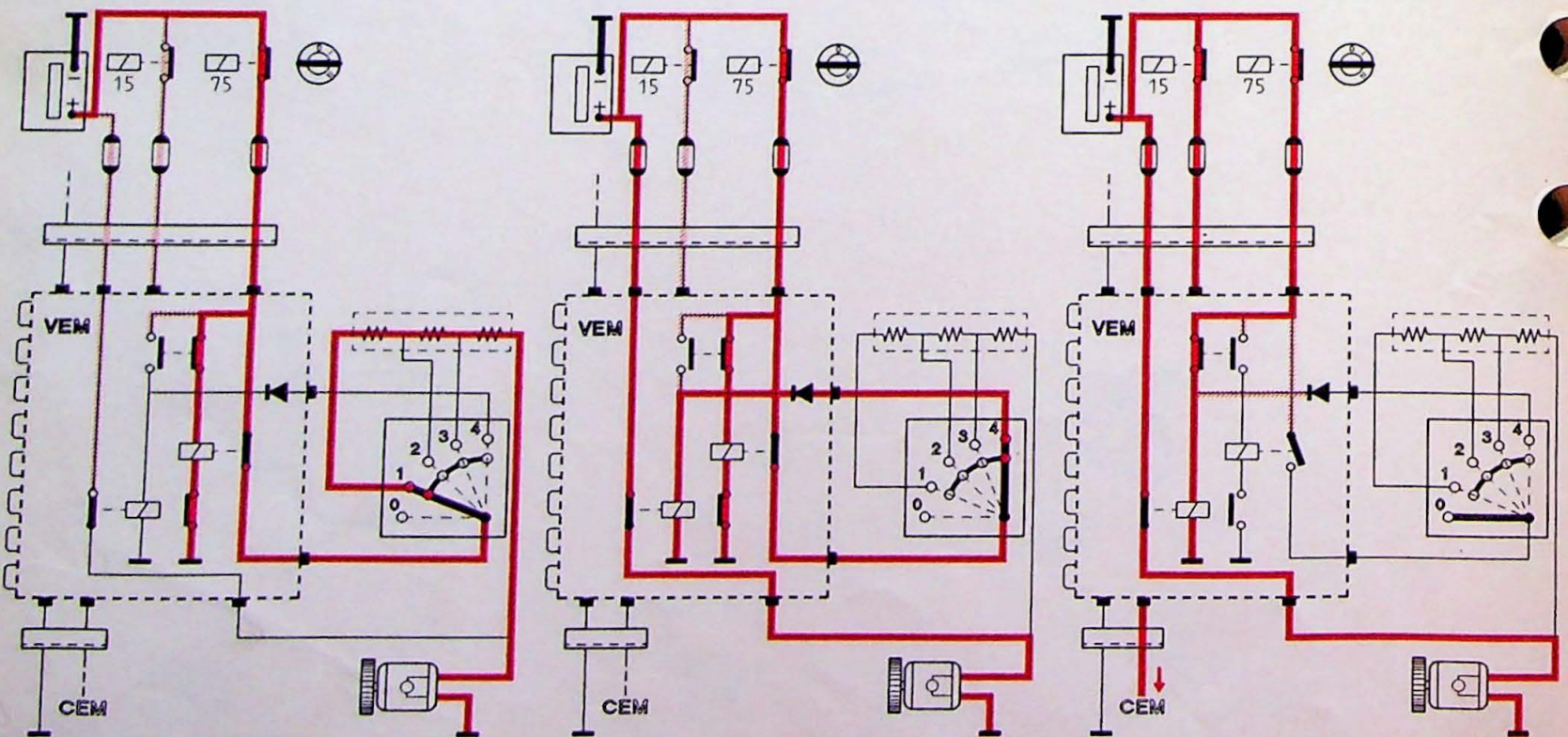

8-013/057

# VEM inhoud

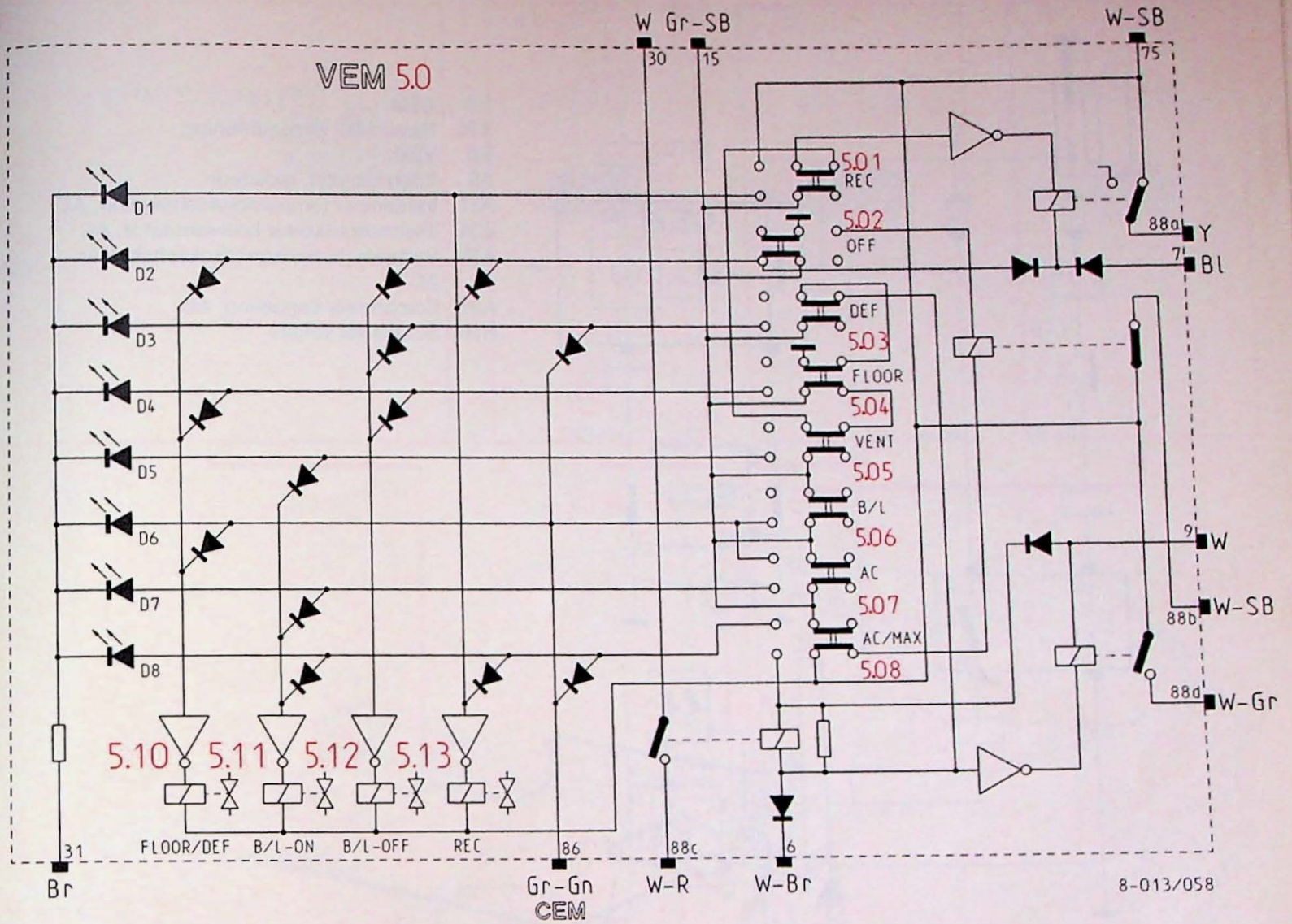

- 5.0 VEM
- 5.01 Recirculatieschakelaar, verwarming
- 5.02 AAN/UIT schakelaar, verwarming
- 5.03 Ontwasemingsschakelaar, verwarming
- 5.04 FLOOR luchtverdelingsschakelaar, verwarming
- 5.05 VENT luchtverdelingsschakelaar, verwarming
- 5.06 B/L luchtverdelingsschakelaar, verwarming
- 5.07 AC schakelaar, airconditioning
- 5.08 AC MAX schakelaar, airconditioning
- 5.10 Luchtklep FLOOR/ontwaseming
- 5.11 Luchtklep B/L-aan
- 5.12 Luchtklep B/L-uit
- 5.13 Luchtklep, recirculatie

# Airconditioning

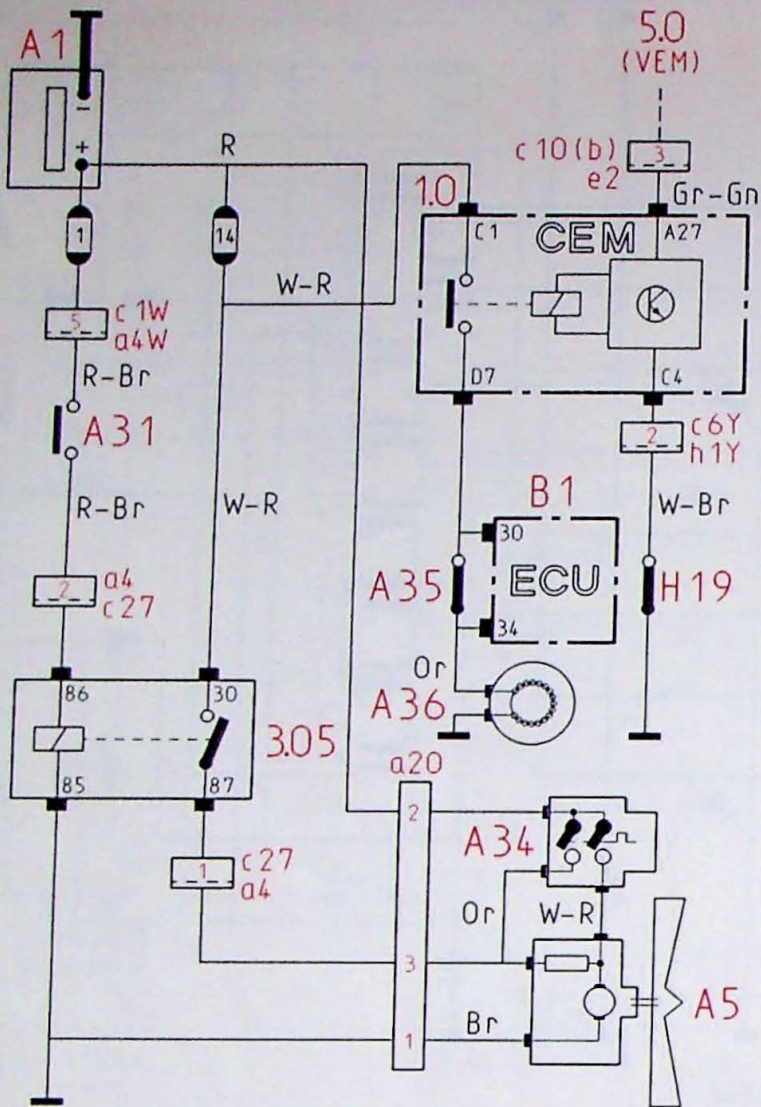

- 1.0 CEM
- 3.05 Relais (AC) airconditioning
- 5.0 VEM
- A5 Koelventilator, radiator
- A31 Verdampfer temperatuurschakelaar, AC
- A34 Thermoschakelaar koelventilator, AC
- A35 Systeem (hoge/lage) drukschakelaar, AC
- A36 Compressor koppeling, AC
- H19 Schakelaar volgass

AC aan, motor draait, signaal naar ECU

Volgas, relais compressor uitgeschakeld

Temperatuur te hoog, ventilator werkt continu. Druk te hoog, compressor uitgeschakeld

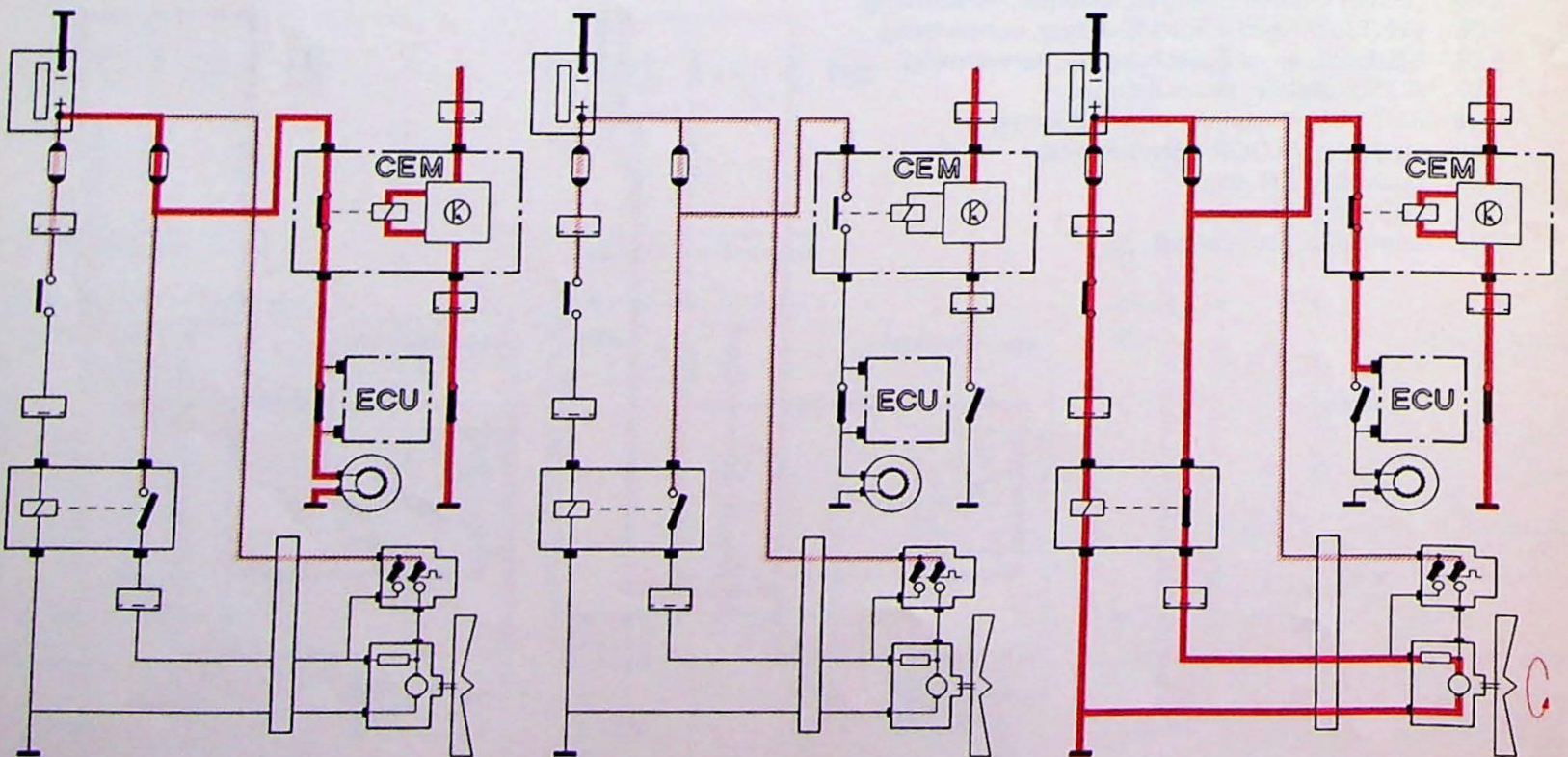

8-013/067

# Airconditioning

c10(b)

c10(b) ↔ e2(b)

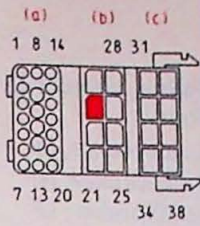

23=Gr-Gn

c6Y

c6Y ↔ h1Y

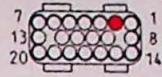

2 =W-Br

c4W

c4W ↔ a1W

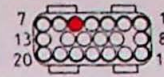

5 =R-Br

a3

a3 ↔ c19

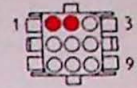

1 =Or  
2 =R-Br

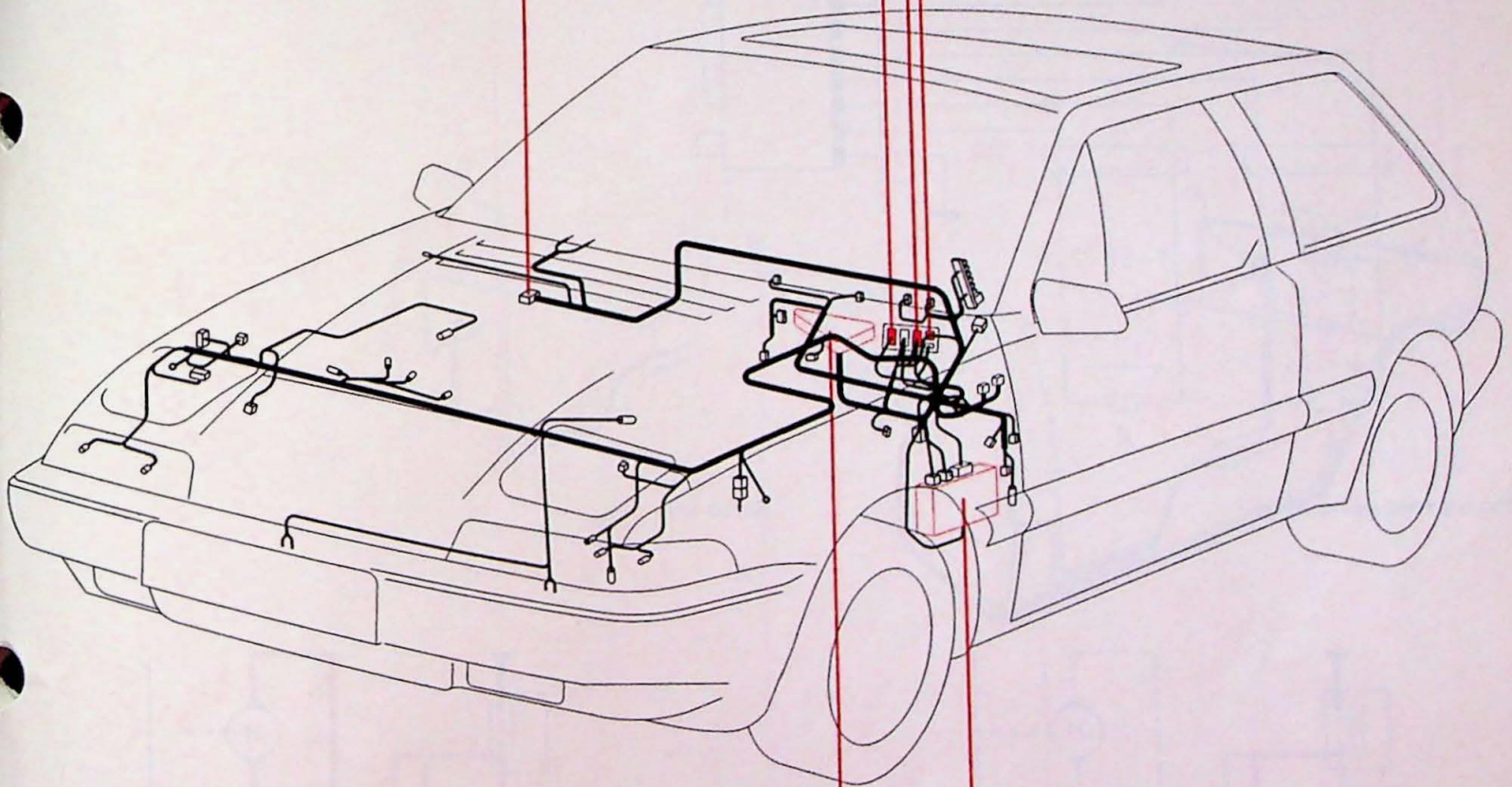

3.0

3.05

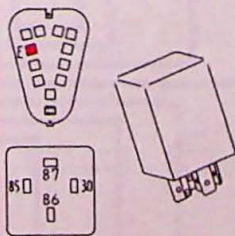

30=W-R  
85=Br  
86=R-Br  
87=Or

1.0

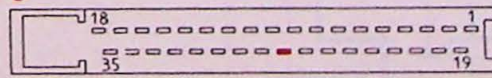

A

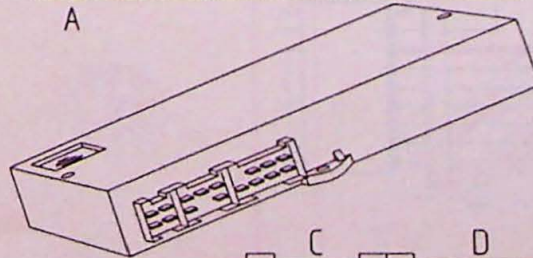

A27=Gr-Gn  
C1=W-R  
C4=W-Br  
D7=Or

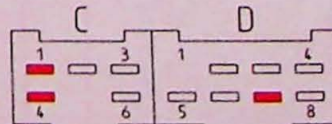

# Radio

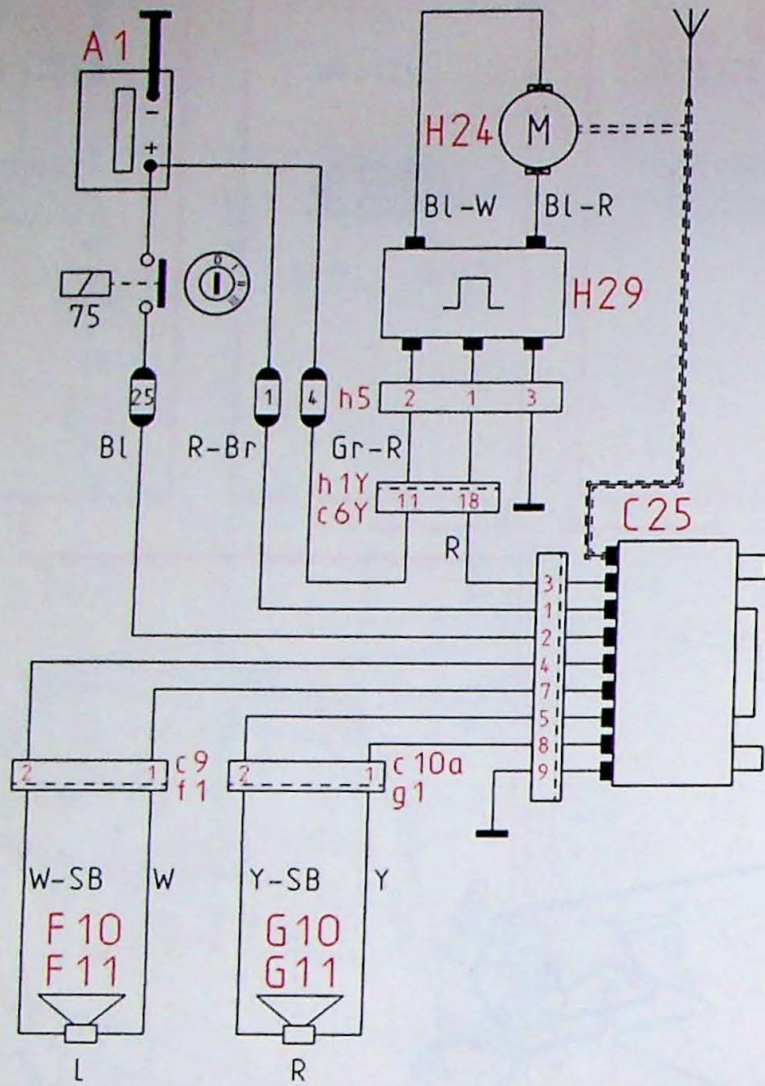

- 3.04 Relais, contact 75
- C25 Radio
- F10 Luidspreker, LF
- F11 Luidspreker, HF
- F10 Luidspreker, LF
- F11 Luidspreker, HF
- H24 Motor radio-antenne
- H29 Relais antennemotor

Radio uit met geheugen

Radio aan

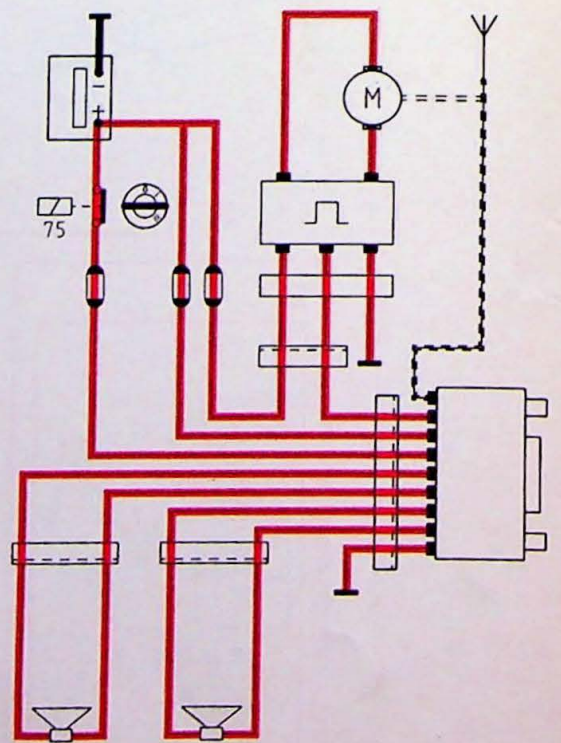
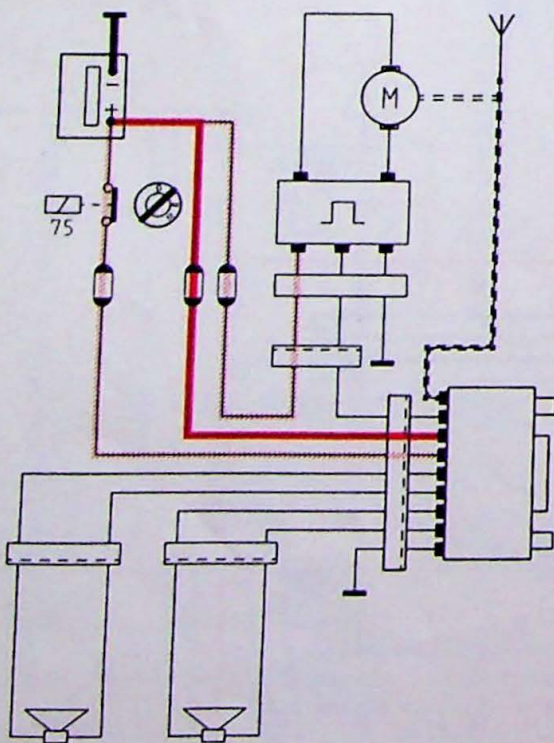

8-013/059

# Radio

G10-G11

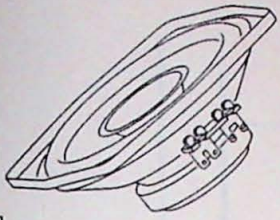

0000

c6Y

c6Y ↔ h1Y

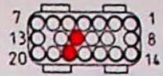

11=Gr-R  
18=R

H24

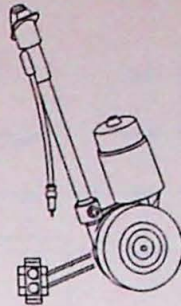

BL-R  
BL-W

H29

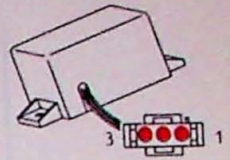

1 = R  
2 = Gr-R  
3 = Br

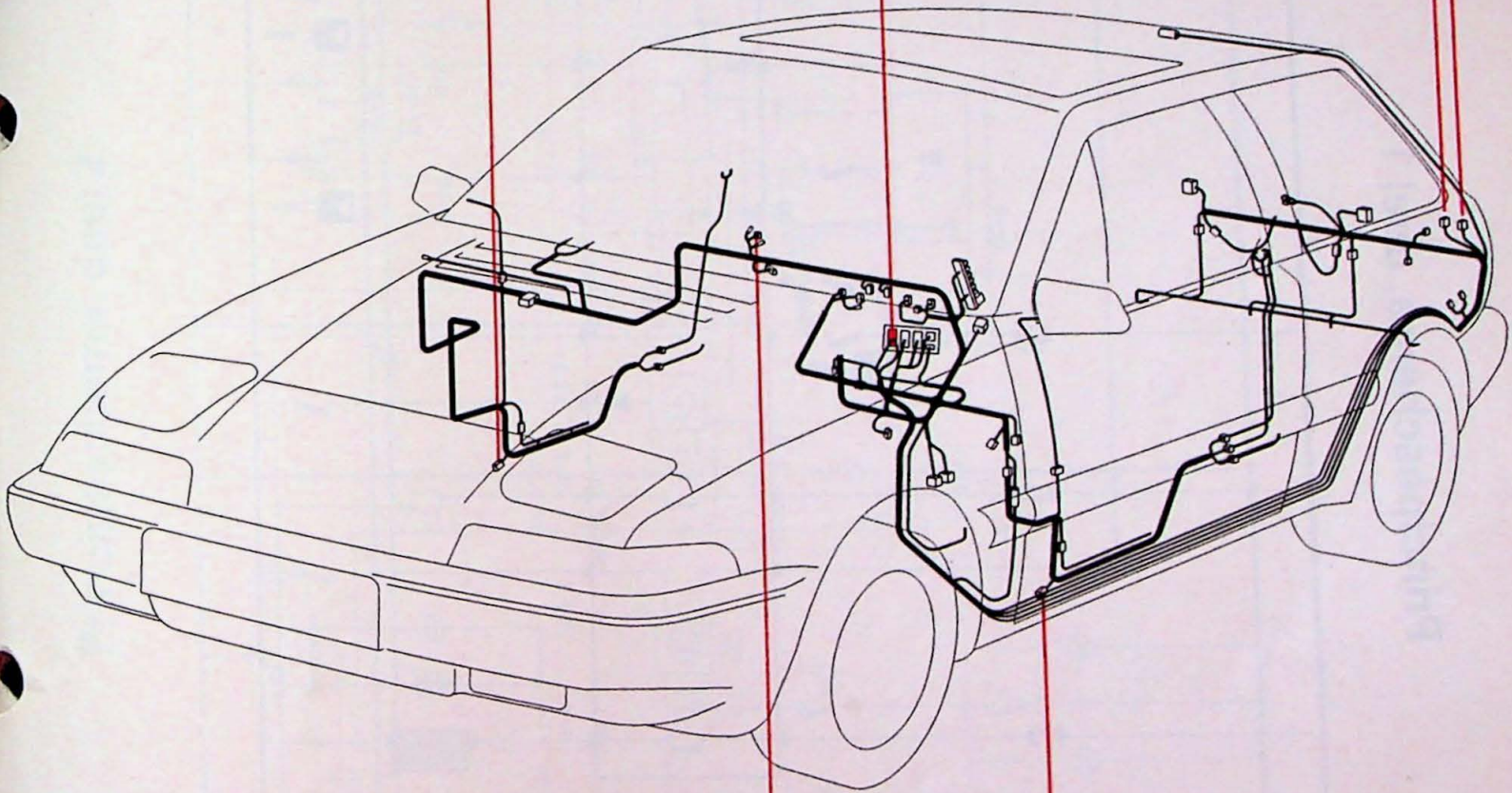

c22-C25

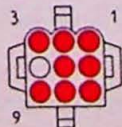

1 = R-Br    5 = Y-SB  
2 = Bl      7 = W  
3 = R        8 = Y  
4 = W-SB    9 = Br

F10-F11

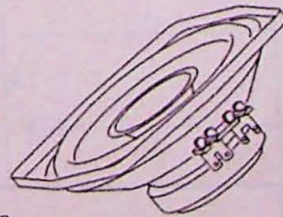

0000

# Principeschema, deel 1

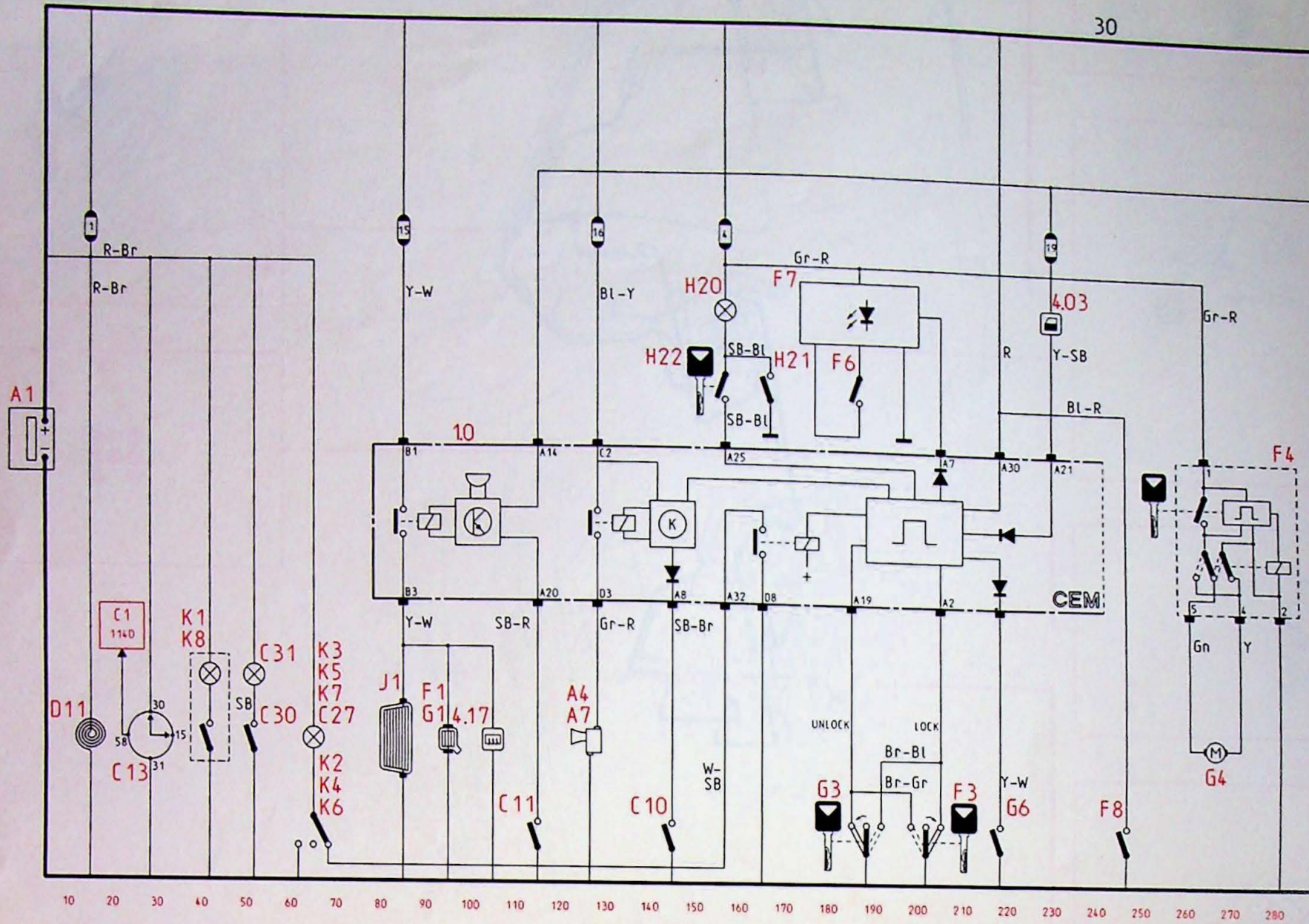



# Principeschema, deel 3

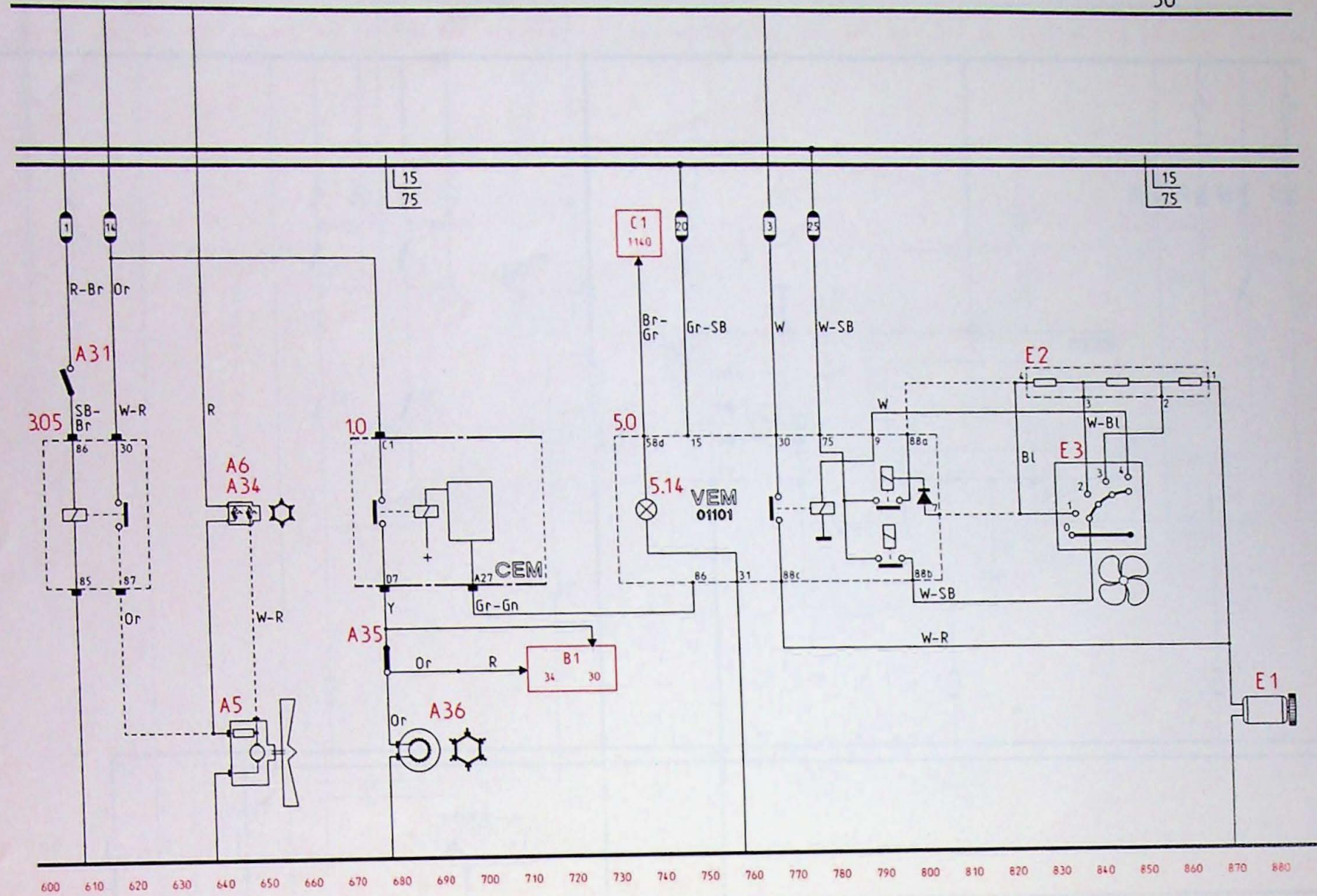

600 610 620 630 640 650 660 670 680 690 700 710 720 730 740 750 760 770 780 790 800 810 820 830 840 850 860 870 880



# Principeschema, deel 5

30

75

15

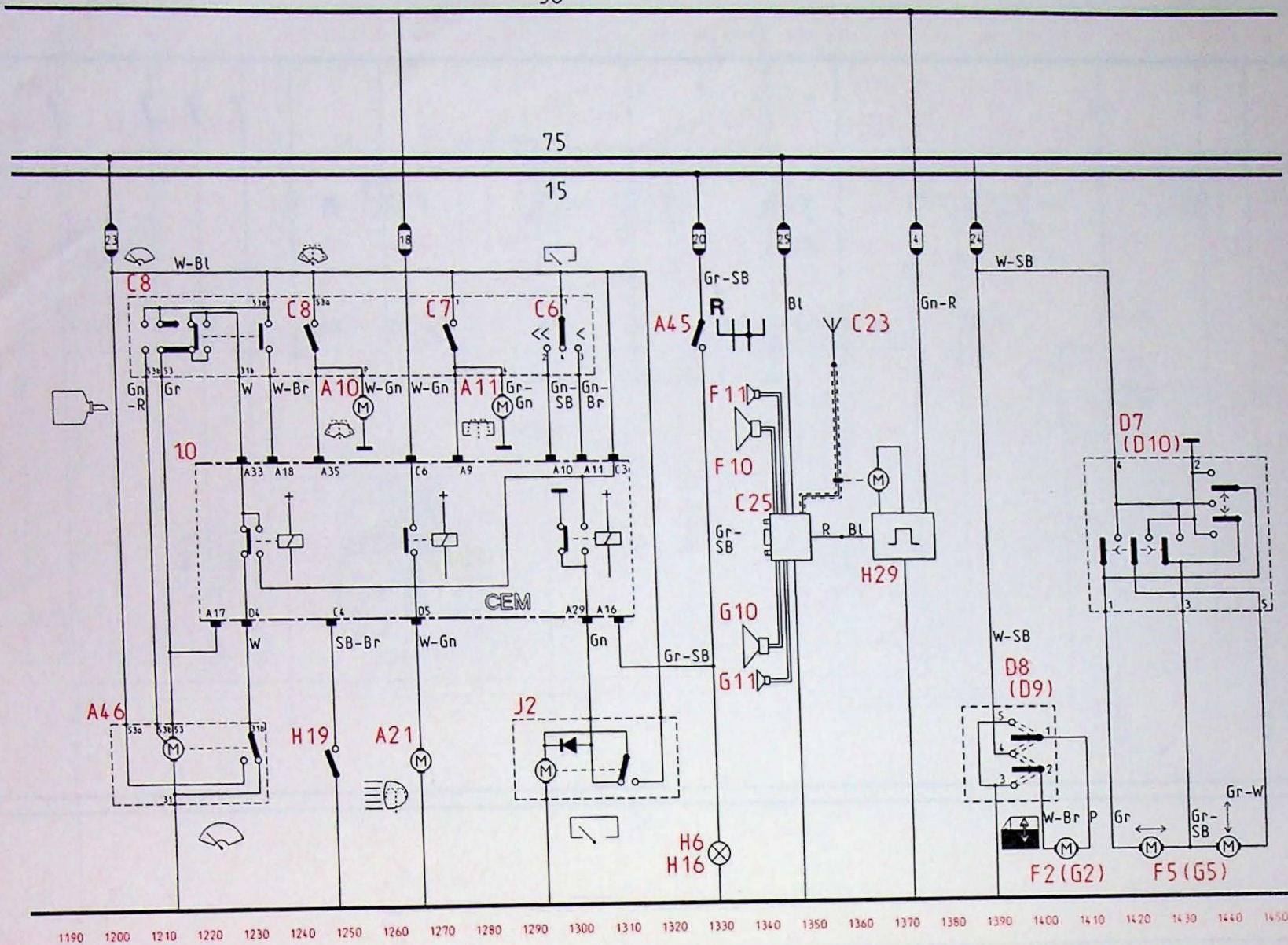

# Principeschema, deel 6

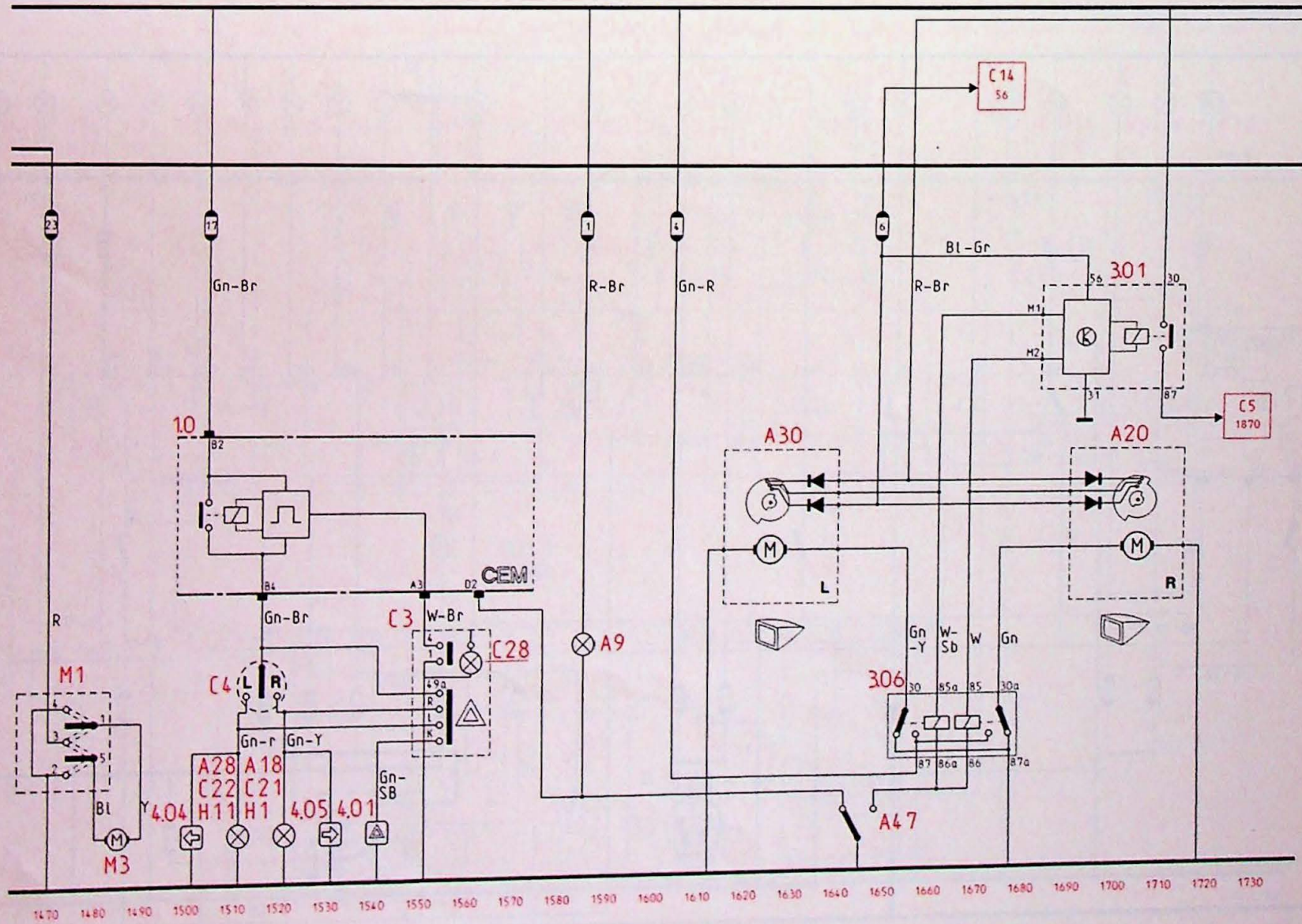

# Principeschema, deel 7

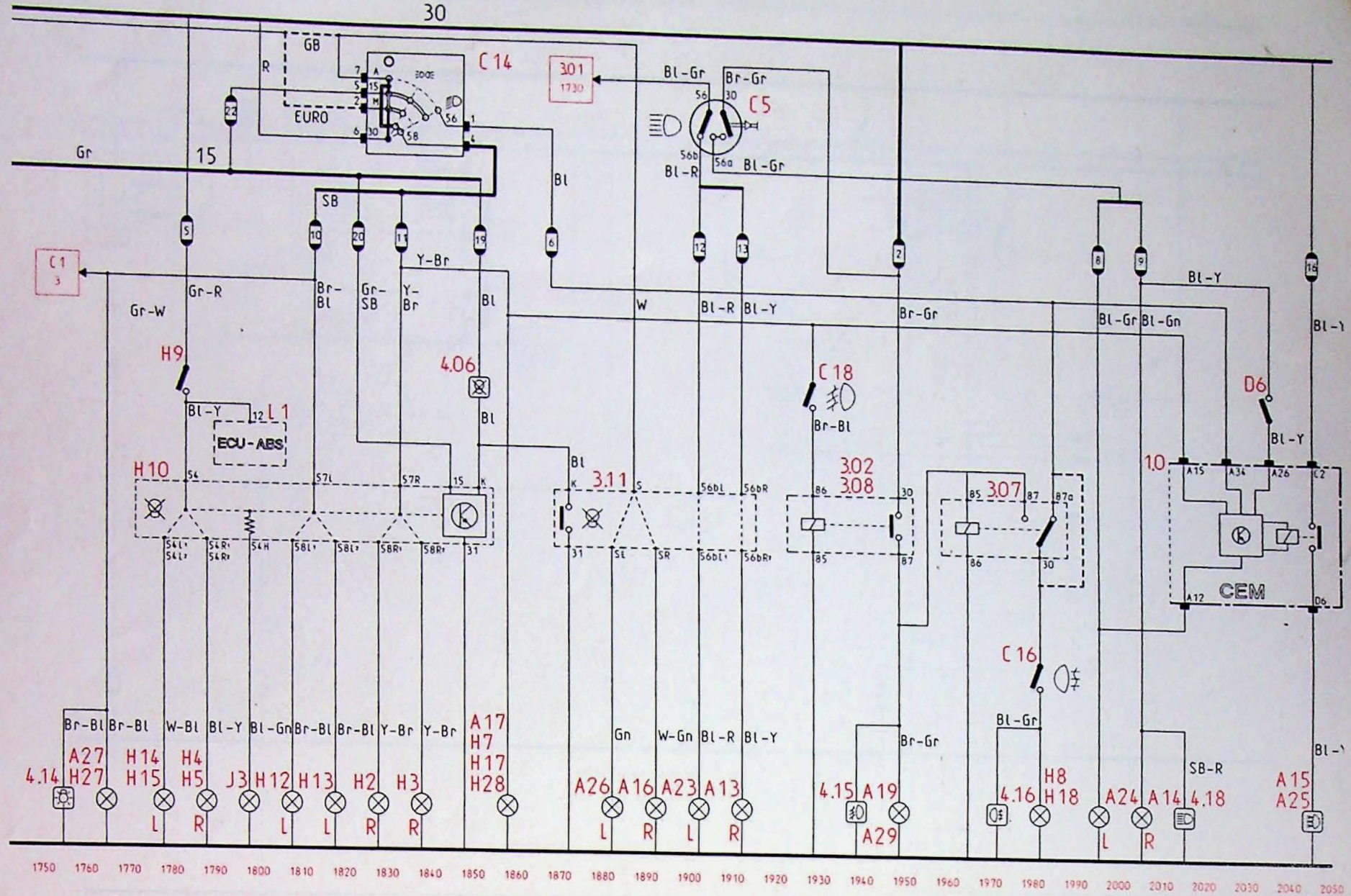

# Principeschema, E-motor

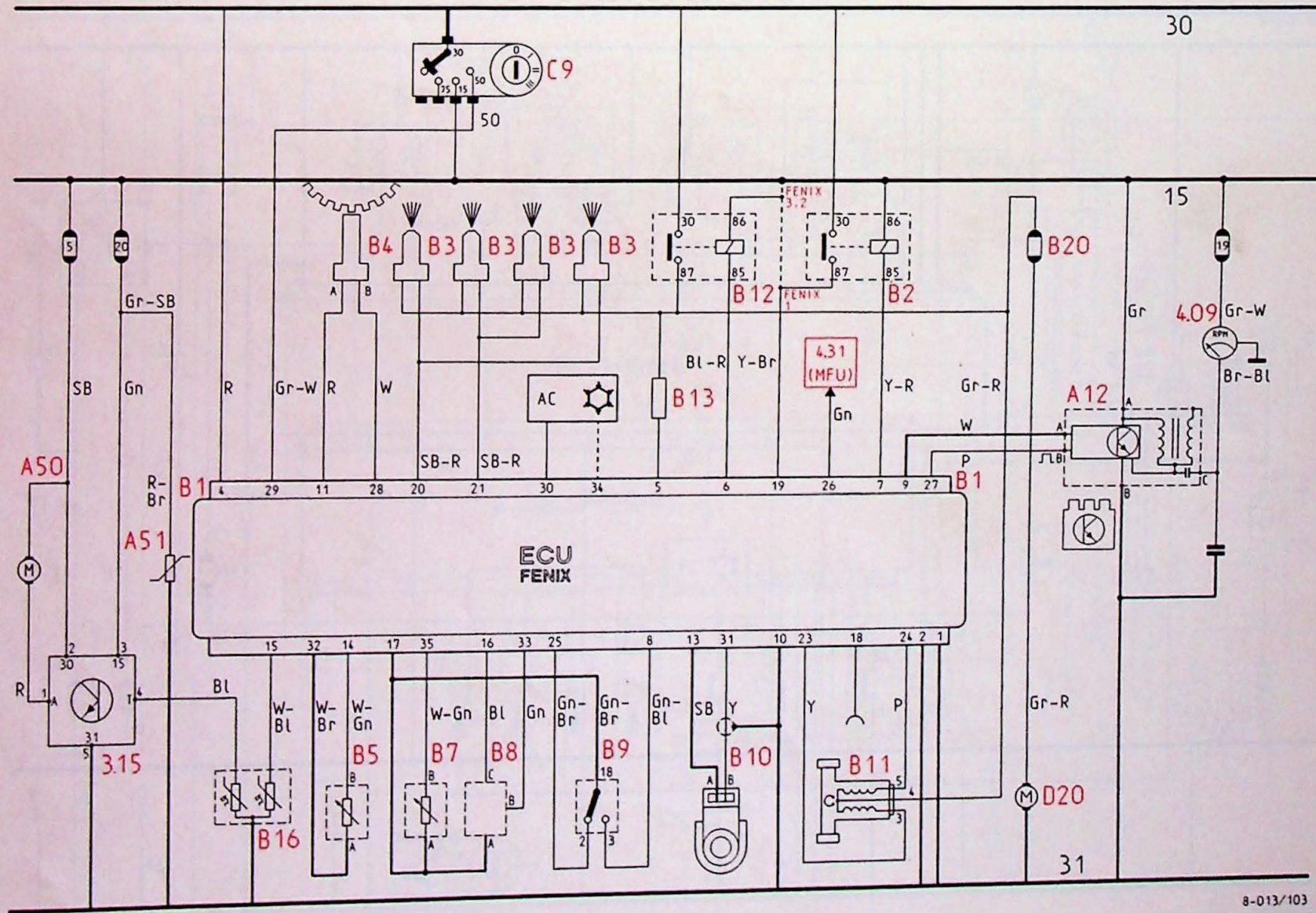

8-013/103

# Principeschema, F-motor

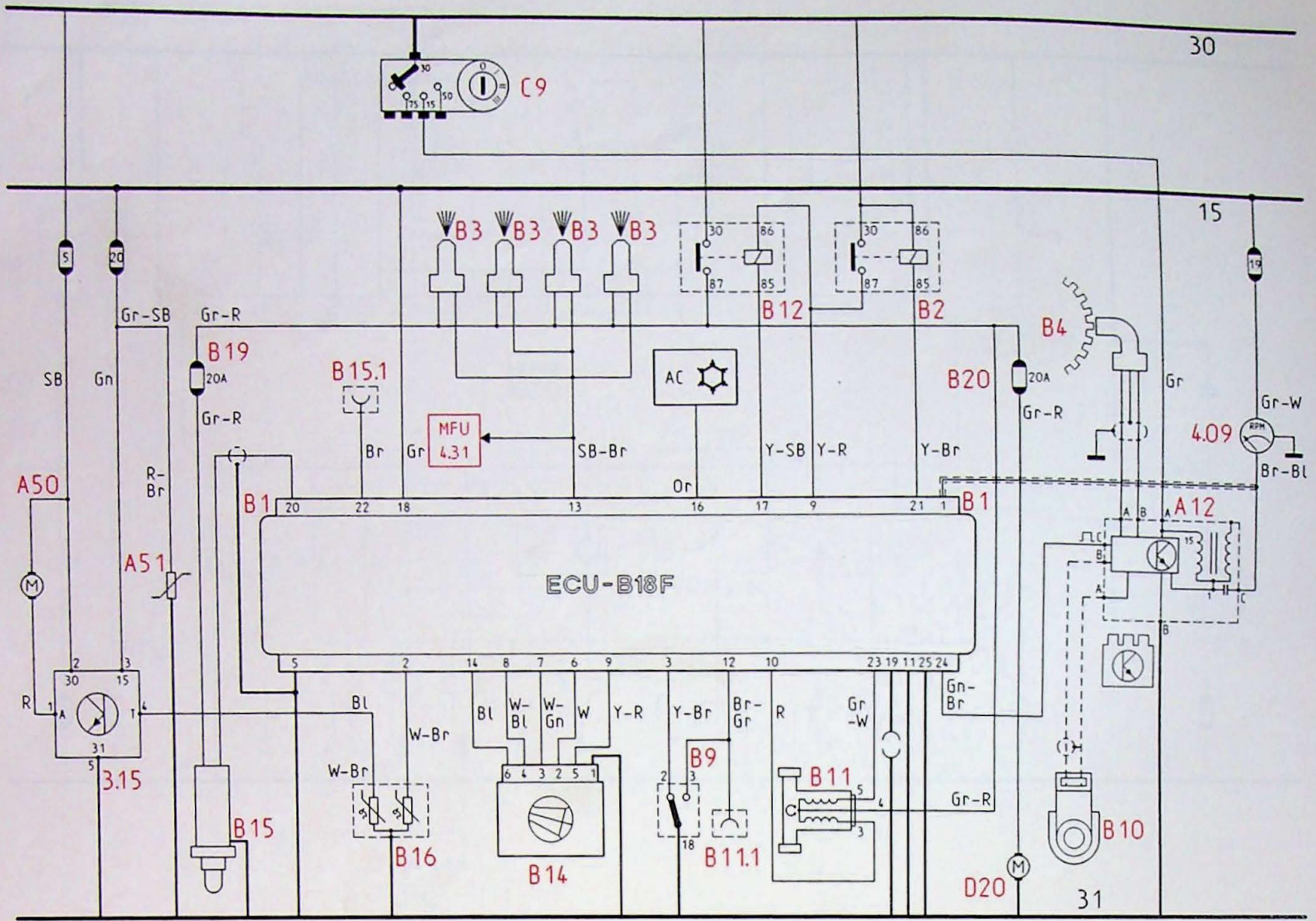

# Principeschema, FT-motor

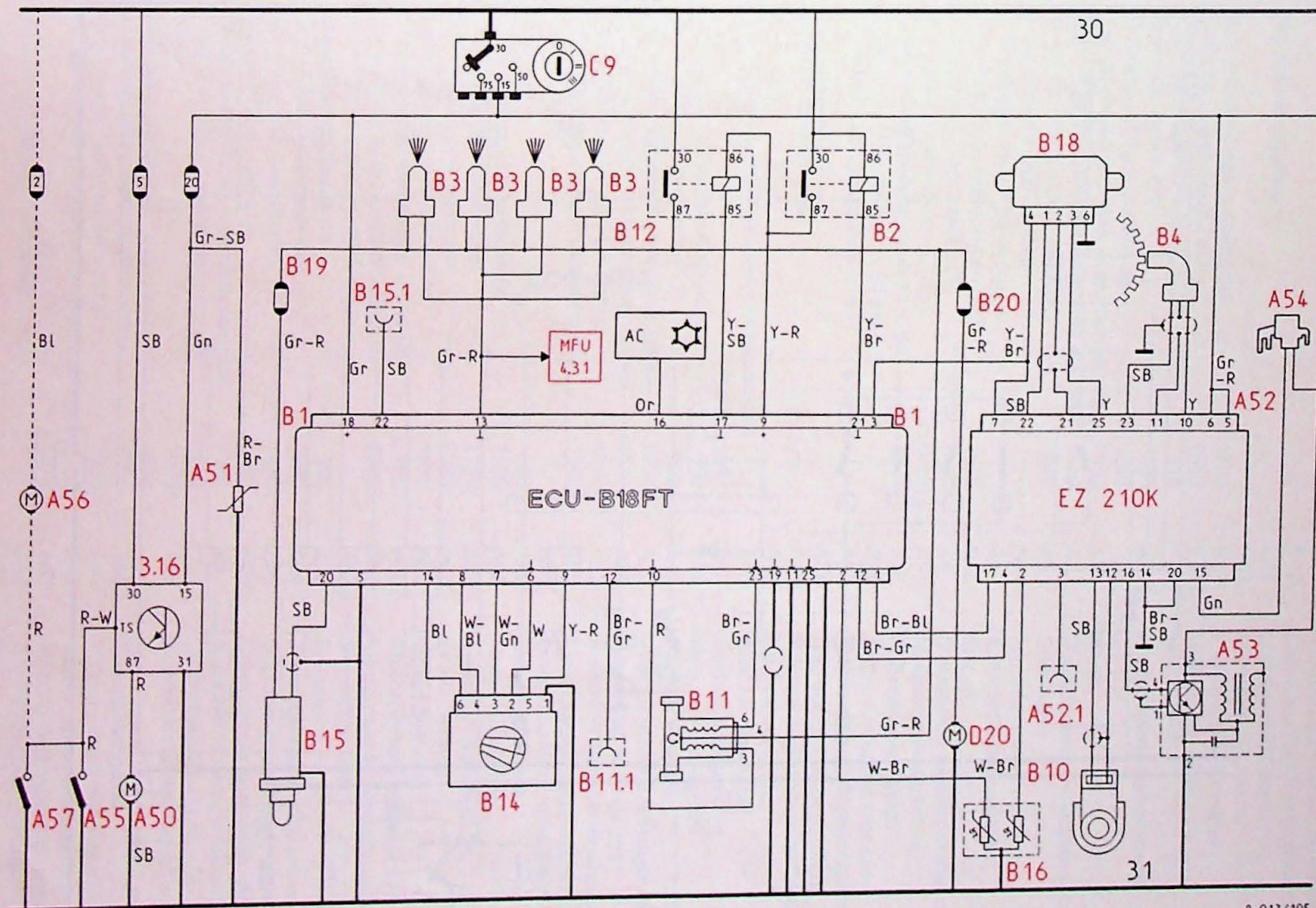

8-013/105

# Principeschema ABS systeem

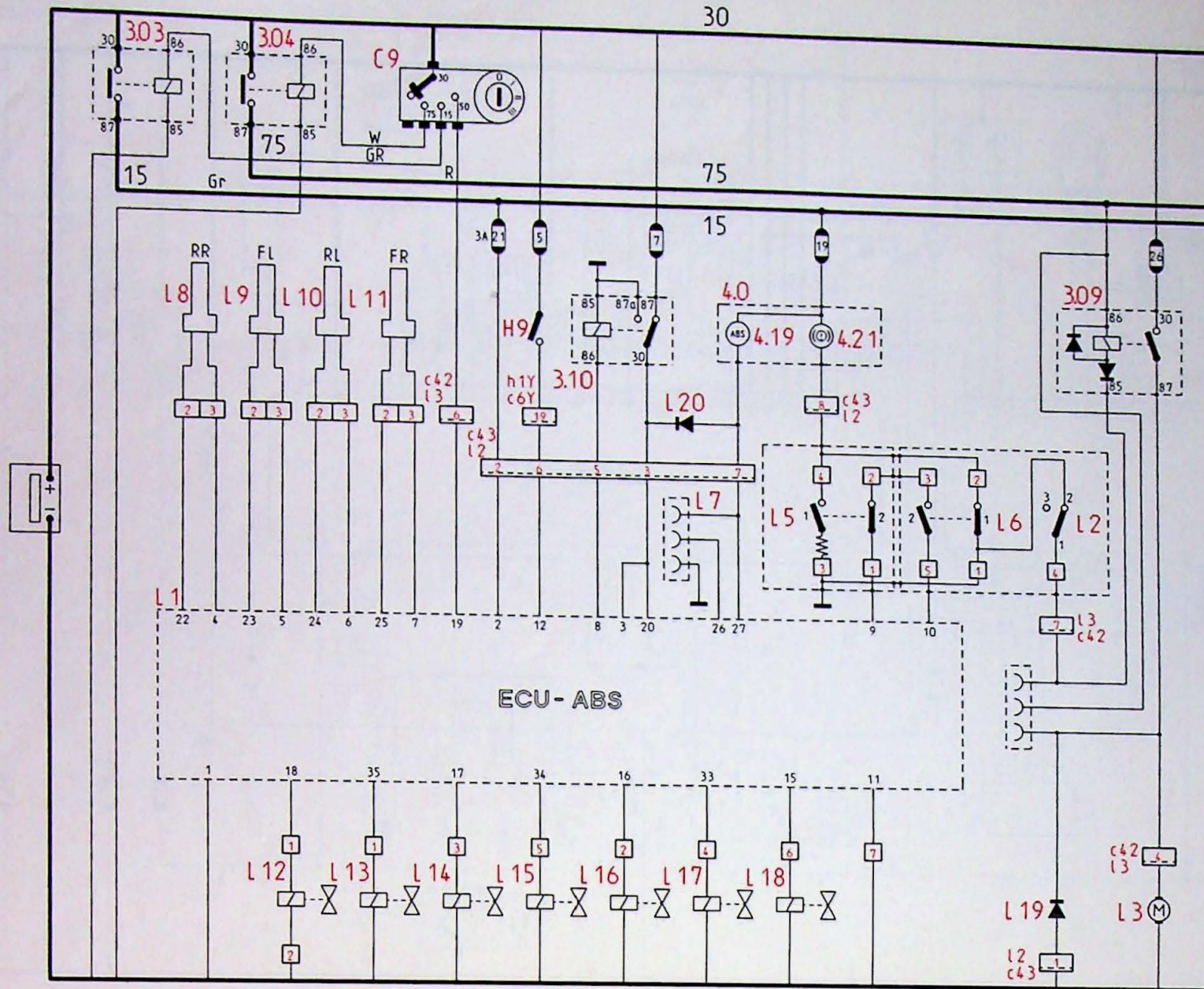

## Componentenlijst op nummer

Num-mer	Component	positie	Num-mer	Component	positie
1.0	CEM		5.06	B/L luchtverdelingsschakelaar, verwarming	
2.0	Zekeringenkast		5.07	AC schakelaar, airconditioning	
3.0	Relaiskast, posities		5.08	AC MAX schakelaar, airconditioning	
3.01	A-Koplampvoeding-sperrelais	1700	5.10	Luchtklep FLOOR/ontwaseming	
3.02	B-Relais, mistlampen (1987)	1940	5.11	Luchtklep B/L-aan	
3.03	C-Ontstekingsrelais (contact 15)	310	5.12	Luchtklep B/L-uit	
3.04	D-Relais, contact 75	350	5.13	Luchtklep, recirculatie	
3.05	E-Relais, AC (airconditioning)	610	5.14	Verlichting, VEM	
3.06	F-Dubbelwerkendrelais, koplampmotoren	1660	<b>A</b>	<b>Motorruimte kabelboom</b>	
3.07	G-Wisselrelais, mistachterlampen (NL, N)	1970	A1	Accu	10
3.08	H-Relais, mistlampen(1988...)	1940	A2	Dynamo en spanningsregelaar	460
3.09	K-Pomprelais, ABS-systeem		A3	Startmotor	420
3.10	J-Voedingsrelais, ABS-systeem		A4	Tweede claxon	130
3.11	L-Defectgever, gloeilampen voor	1910	A5	Koelventilator, radiateur	650
3.12	H-Sperrelais, mistlampen (N)		A7	Claxon	130
3.13	A-Koplampvoedingsrelais (GB)		A8	Schakelaar, motorruimteverlichting	
3.14	G-sperrelais, gedimd-dimlicht (GB)		A9	Motorruimteverlichting	1590
3.15	D-Relais, hulpwaterpomp, B18 E + F		A10	Ruitesproeierpomp	1260
3.16	D-Relais, hulpwaterpomp, B18 FT		A11	Achterraut-sproeierpomp	1280
<b>4.0</b>	<b>Instrumentenpaneel</b>		A12	Elektronische ontstekingseenheid	
4.01	Controlelamp, waarschuwingssknipperlichten	1540	A13	Rechter koplamp, dimlicht	1910
4.02	Controlelamp, veiligheidsgordels	520	A14	Rechter koplamp, grootlicht	2010
4.03	Controlelamp, "deur open"	230	A15	Rechter verstraler	2050
4.04	Controlelamp, richtingaanwijzer, links	1500	A16	Rechter dagrijlicht	1890
4.05	Controlelamp, richtingaanwijzer, rechts	1530	A17	Rechter parkeerlicht	1860
4.06	Controlelamp, defecte gloeilamp(en)	1860	A18	Rechter richtinglicht	1520
4.07	Controlelamp, laag-sproeiwaterpeil	940	A19	Rechter mistlamp	1950
4.09	Toerenteller		A20	Motor, rechter koplamphuis	1700
4.10	Klok	30	A21	Koplampsproeierpomp	1260
4.11	Elektronische snelheidsmeter	1100	A22	Buitenluchttemperatuurgever	1060
4.14	Controlelamp, parkeerlicht	1760	A23	Linker koplamp, dimlicht	1900
4.15	Controlelamp, mistlampen	1940	A24	Linker koplamp, grootlicht	2000
4.16	Controlelamp, mistachterlicht	1970	A25	Linker verstraler	2050
4.17	Controlelamp, verwarmde achterraut	100	A26	Linker dagrijlicht	1880
4.18	Controlelamp, grootlicht/lichtsignaal	2020	A27	Linker parkeerlicht	1760
4.19	Waarschuwingsslamp, ABS-systeem		A28	Linker richtinglicht	1510
4.20	Controlelamp, handrem	950	A29	Linker mistlamp	1950
4.21	Controlelamp, remvloeistof	930	A30	Motor, linker koplamphuis	1630
4.22	Controlelamp, laadstroom	470	A31	Verdamper temperatuurschakelaar, AC	610
4.23	Controlelamp, oliedruk	910	A32	Stroomverdeler	
4.26	Buitentemperatuur, informatiecentrum	1060	A33	Bougies	
4.29	Olietemperatuur, informatiecentrum	1030	A34	Thermoschakelaar koelventilator, AC	650
4.31	MFU	1000	A35	Systeem (hoge/lage)-drukschakelaar, AC	680
4.32	Informatiecentrum (LCD-paneel)	980	A36	Compressor koppeling, AC	680
4.33	LCD verlichting, informatiecentrum	1080	A37	Waterslang-temperatuurschakelaar, (kachelventilator)	
4.34	Verlichting, instrumentenpaneel	1080	A39	Koelvloeistof-temperatuurgever, instrumenten	980
4.35	15/30 Voedingsrelais, instrumentenverlichting	1070	A40	Olie-niveaugever	1010
4.50	Kanaalschakelaar, informatiecentrum		A41	Vlotter remvloeistofcontrole	930
<b>5.0</b>	<b>VEM</b>	790	A42	Vlotter sproeiervloeistofcontrole	940
5.01	Recirculatieschakelaar, verwarming		A43	Motorolie-temperatuurgever	1030
5.02	AAN/UIT schakelaar, verwarming		A44	Snelheidsgever, eindaandrijving HL	1110
5.03	Ontwasemingsschakelaar, verwarming		A45	Schakelaar achteruitrijlichten	1330
5.04	FLOOR luchtverdelingsschakelaar, verwarming		A46	Ruitewissermotor	1210
5.05	VENT luchtverdelingsschakelaar, verwarming		A47	Schakelaar, motorkapslot	1640
			A48	Olie-drukgever + schakelaar HL	1160
			A49	Gedimd-dimlicht relais (GB)	
			A50	Hulpwaterpomp B18 F en FT	
			A51	Thermistor, verwarming carterventilatiesysteem, B18 F en FT	

# Componentenlijst op nummer

Num-mer	Component	positie	Num-mer	Component	positie
A52	Regeleenheid, elektronische ontsteking + laaddruk, B18 FT		C31	Handschoenenkastverlichting	50
A52.1	Diagnose-aansluiting A52		C32	Oliedrukmeter	1170
A53	Eindtrap en bobine, B18 FT		C33	Accuvoltmeter	1180
A54	Turbo-laaddrukregelklep, B18 FT		C34	Verlichting, lichtschakelaar	
A55	Temperatuurgever, turbo-compressor B18 FT		<b>D</b>	<b>Tunnelconsole kabelboom</b>	
A56	Koelventilator, inspuitventielen B18 FT		D1	Zoekverlichting middenconsole schakelaars	
A57	Inspuitventielen-temperatuurgever, B18 FT		D2	Schakelaar, stoelverwarming bestuurder	370
A58	Olieniveau + temperatuurgever	1010	D3	Lamp, stoelverwarmingsschakelaar bestuurder	380
A62	Schakelaar startonderbreking automaat		D4	Schakelaar, stoelverwarming passagier	390
<b>B</b>	<b>Brandstofsysteem kabelboom</b>		D5	Lamp, stoelverwarmingsschakelaar passagier	400
B1	Stuureenheid (ECU), brandstofinspuitsysteem		D6	Schakelaar verstralers	240
B2	Stuurrelais, brandstofinspuitsysteem		D7	Instelknop, achteruitkijkspiegel links	1430
B3	Inspuitventielen		D8	Schakelaar, elektrisch bedienbare zijruit, links	1390
B4	Motortoerentalgever, vliegwiel		D9	Schakelaar, elektrisch bedienbare zijruit, rechts	1390
B5	Inlaatlucht-temperatuurgever, inspuitsysteem		D10	Instelknop, achteruitkijkspiegel rechts	1430
B6	Koelvloeistof-temperatuurgever, inspuitsysteem		D11	Aansteker	20
B7	Potentiometer, CO-afstelling		D12	Verlichting aansteker	1130
B8	Luchtdrukgever, inspuitsysteem		D13	Gordelcontact bestuurder	560
B9	Smookklepschakelaar, B18 E en B18 F		D14	Stoelverwarmingselement en thermostaat, bestuurder	370
B10	Pingelsensor		D15	Stoelverwarmingselement en thermostaat, passagier	390
B11	Regelklep, stationair toerental		D16	Zitcontact voorste passagiersstoel	580
B11.1	Diagnose-aansluiting voor B11 (B18 F en B18 FT)		D17	Gordelcontact passagier	580
B12	Brandstofpomprelais		D18	Schakelaar handrem	950
B13	Modulatieklep, uitlaatgas-recirculatiesysteem (EGR)		D19	Tank geveer, brandstofmeter	960
B14	Luchtmassa-meter, B18 F en FT		D20	Brandstofpomp	
B15	Zuurstofsensor, B18 F en FT		D21	Verlichting asbak	1130
B15.1	Diagnose-aansluiting voor zuurstofsensor		D22	Zoekverlichting, gordelsluiting bestuurder	570
B16	Koelvloeistof-temperatuurgever hulpwaterpomp		D23	Zoekverlichting, gordelsluiting passagier	590
B18	Smookklepschakelaar en klepstandsensoren, B18 FT		D24	Verlichting, keuzehendelpaneel, Automaat	1130
B19	Zekering (naast B2), Zuurstofsensor, B18 F en FT		<b>E</b>	<b>Verwarmingssysteem kabelboom</b>	
B20	Zekering (naast B12), Brandstofpomp, B18 F en F		E1	Motor, kachelventilator	870
<b>C</b>	<b>Centrale kabelboom</b>		E2	Voorschakelweerstand, kachelventilator	840
C1	Dimmer dashboardverlichting	1130	E3	Schakelaar kachelventilator	840
C3	Schakelaar waarschuwingslichten	1550	E4	Verlichting, kachelventilatorschakelaar	1130
C4	Schakelaar richtingaanwijzers	1510	E5	Relais, ventilatormotor snelheid 1, AC	790
C5	Grootlicht-/dimlichtschakelaar	1950	E6	Relais, ventilatormotor, AC MAX	780
C6	Schakelaar achterrautwisser	1300	<b>F</b>	<b>Bestuurdersportier kabelboom</b>	
C7	Schakelaar achterrautsproeier	1280	F1	Verwarmingselement, achteruitkijkspiegel bestuurderszijde	90
C8	Ruitwisser-/wasschakelaar	1220	F2	Motor, elektrisch bedienbare zijruit, portier bestuurder	1410
C9	Contact-/startschakelaar	390	F3	Portierslotschakelaar, bestuurder	210
C10	Schakelaar claxon	140	F4	Schakelaar, centrale vergrendeling	270
C11	Schakelaar achterrautverwarming	110	F5	Motoren, achteruitkijkspiegel bestuurderszijde	1440
C13	Klok	30	F6	Schakelaar, sleutelgat-verlichting	180
C14	Lichtschakelaar	1840	F7	Sleutelgat-verlichting	170
C16	Schakelaar mistachterlicht	1980	F8	Deurschakelaar, portier bestuurder	250
C18	Mistlampschakelaar	1930	F10	Luidspreker, LF	1340
C21	Lamp, rechter spatbord richtinglicht	1520	F11	Luidspreker, HF	1340
C22	Lamp, linker spatbord richtinglicht	1510			
C24	Kabel, radio-antenne	1360			
C25	Radio	1350			
C26	Verlichting, radio	1120			
C27	Zoekverlichting, contactslot	70			
C28	Verlichting, waarschuwingsknipperlichten schakelaar	1560			
C29	Verlichting, centrale instrumentenpaneel				
C30	Schakelaar, handschoenenkastverlichting	50			

## Componentenlijst op nbetisch

Num-mer	Component	positie	Num-mer	Component	Num-mer
<b>G</b>	<b>Passagiersportier kabelboom</b>		<b>L</b>	<b>ABS kabelboom</b>	
G1	Verwarmingselement, achteruitkijkspiegel passagierszijde	90	L1	Stuureenheid, ABS-systeem	125
G2	Motor, elektrisch bedienbare zijruit, portier passagier	1410	L2	Systeemdruckschakelaar, ABS-systeem	14
G3	Portierslotschakelaar, portier passagier	190	L3	Pompmotor, ABS-systeem	13
G4	Motor, centrale vergrendeling	270	L4	Test steker, ABS pomp	9
G5	Motoren, achteruitkijkspiegel passagierszijde	1440	L5	Vlotter ABS-vloeistofcontrole	
G6	Deurschakelaar, portier passagier	220	L6	Schakelaar, waarschuwinglamp ABS-systeem	
G10	Luidspreker, LF	1340	L7	Steker, ABS-systeem diagnose	
G11	Luidspreker, HF	1340	L8	Snelheidsgever, rechter achterwiel, ABS	
<b>H</b>	<b>Achterkant kabelboom</b>		L9	Snelheidsgever, linker voorwiel, ABS	
H1	Lamp richtingaanwijzer, rechts	1520	L10	Snelheidsgever, linker achterwiel, ABS	
H2,H3	Lamp achterlicht, rechts	1840	L11	Snelheidsgever, rechter voorwiel, ABS	
H4,H5	Lamp remlicht, rechts	1790	L12	Systeemventiel, ABS	
H6	Lamp achteruitrijlicht, rechts	1320	L13	Inlaatventiel, linker voorwiel, ABS	
H7	Lamp kentekenverlichting, rechts	1860	L14	Inlaatventiel, achterwielen, ABS	
H8	Lamp mistachterlicht, rechts	1980	L15	Uitlaatventiel, rechter voorwiel, ABS	
H9	Schakelaar remlichten	1780	L16	Uitlaatventiel, linker voorwiel, ABS	
H10	Defectgever, gloeilampen achter	1810	L17	Uitlaatventiel, achterwielen, ABS	
H11	Lamp richtingaanwijzer, links achter	1510	L18	Inlaatventiel, rechter voorwiel, ABS	
H12,H13	Lamp achterlicht, links	1820	L19	Diode	
H14,H15	Lamp remlicht, links	1780	L20	Diode	
H16	Lamp achteruitrijlicht, links	1320	<b>M</b>	<b>Schuifdak kabelboom</b>	
H17	Lamp kentekenverlichting, links	1860	M1	Schakelaar schuif/kanteldak	1470
H18	Lamp mistachterlicht, links	1980	M3	Motor schuif/kanteldak	1480
H19	Schakelaar volgas	1250			
H20	Kofferruimteverlichting	160			
H21	Schakelaar kofferruimteverlichting	170			
H22	Schakelaar achterklepslot	160			
H24	Motor, radio-antenne	1370			
H25	Radio-antenne	1370			
H27	Lamp, achterlicht rechter zijwand	1770			
H28	Lamp, achterlicht linker zijwand	1860			
H29	Relais, antennemotor	1370			
<b>J</b>	<b>Achterklep kabelboom</b>				
J1	Verwarmingselement, achterrauit	80			
J2	Achterrauitwissermotor	1300			
J3	Remlicht midden	1800			
<b>K</b>	<b>Binnenverlichting kabelboom</b>				
K1	Leeslamp, achterpassagier links	40			
K2	Schakelaar, binnenverlichting	70			
K3	Lamp, binnenverlichting	70			
K4	Schakelaar linker leeslamp	70			
K5	Linker leeslamp, binnenverlichting	70			
K6	Schakelaar rechter leeslamp	70			
K7	Rechter leeslamp, binnenverlichting	70			
K8	Leeslamp, achterpassagier rechts	40			

# Compuummer

## + alfabetisch

Num- mer	Cr positie	Positie	Num- mer		
A52			5.02	Gedimd-dimlicht relais (GB)	A49
			D11	Gordelcontact passagier	D17
A52.1	airconditioning	20	5.08	Gordelcontact bestuurder	D13
A53	conditioning		5.07	Grootlicht-/dimlichtschakelaar	C5
A54		10	A1	Hulpwaterpomp B18 F en FT	A50
A55		1180	C33	Informatiecentrum (LCD-paneel)	4.32
A56	linker zijwand	1860	H28	Inlaatlucht-temperatuurgever,	B5
A57	rechts	1840	H2,H3	inspuitstelsysteem	
A5'	links	1820	H12,H13	Inlaatventiel, linker voorwiel, ABS	L13
Af	licht rechter zijwand	1770	H27	Inlaatventiel, rechter voorwiel, ABS	L18
	ruit-sproeierpomp	1280	A11	Inlaatventiel, achterwielen, ABS	L14
F	erruitwissermotor	1300	J2	Inspuitventielen-temperatuurgever, B18	A57
	nteruitkijkspiegel rechts	1430	D10	FT	
	achteruitkijkspiegel links	1430	D7	Inspuitventielen	B3
	Achteruitrijlicht, rechts	1320	H6	Kanaalschakelaar, informatiecentrum	4.50
	Achteruitrijlicht, links	1320	H16	Kentekenverlichting, links	H17
	Bougies		A33	Kentekenverlichting, rechts	H7
	Brandstofpomp		D20	Klok	30 4.10
	Brandstofpomprelais		B12	Koelventilator, radiator	650 A5
	Buitenluchttemperatuurgever	1060	A22	Koelventilator, inspuitventielen B18 FT	A56
	Buitemtemperatuur, informatiecentrum	1060	4.26	Koelvloeistof-temperatuurgever	B16
	Claxon	130	A7	hulpwaterpomp	
	Compressor koppeling, AC	680	A36	Koelvloeistof-temperatuurgever,	B6
	Contact-/startschakelaar	390	C9	inspuitstelsysteem	
	Controlelamp, parkeerlicht	1760	4.14	Koelvloeistof-temperatuurgever,	A39
	Controlelamp, defecte gloeilamp(en)	1860	4.06	instrumenten	
	Controlelamp, "deur open"	230	4.03	Kofferruimteverlichting	160 H20
	Controlelamp, mistlampen	1940	4.15	Koplampsproeierpomp	1260 A21
	Controlelamp, richtingaanwijzer, rechts	1530	4.05	Koplampvoeding-sperrelais	1700 3.01
	Controlelamp, verwarmde achterruit	100	4.17	Koplampvoedingsrelais (GB)	3.13
	Controlelamp, richtingaanwijzer, links	1500	4.04	Lamp, binnenverlichting	70 K3
	Controlelamp, laag-sproeiwaterpeil	940	4.07	Lamp, stoelverwarmingsschakelaar	400 D5
	Controlelamp, handrem	950	4.20	passagier	
	Controlelamp, veiligheidsgordels	520	4.02	Lamp, stoelverwarmingsschakelaar	380 D3
	Controlelamp, mistachterlicht	1970	4.16	bestuurder	
	Controlelamp, remvloeistof	930	4.21		
	Controlelamp,	1540	4.01		
	waarschuwingsknipperlichten				
	Controlelamp, laadstroom	470	4.22		
	Controlelamp, oliedruk	910	4.23		
	Controlelamp, grootlicht/lichtsignaal	2020	4.18		
	Defectgever, gloeilampen achter	1810	H10		
	Defectgever, gloeilampen voor	1910	3.11		
	Deurschakelaar, portier bestuurder	250	F8		
	Deurschakelaar, portier passagier	220	G6		
	Diagnose, ABS-systeem		L7		
	Diagnose, ABS pomp		L4		
<b>Component</b>		<b>Positie</b>	<b>Num- mer</b>		
Diagnose-aansluiting A52			A52.1		
Diagnose-aansluiting voor zuurstofsensoren			B15.1		
Diagnose-aansluiting voor B11 (B18 F en B18 FT)			B11.1		
Dimmer dashboardverlichting	1130		C1		
Diode			L20		
Diode			L19		
Dubbelwerkendrelais, koplampmotoren	1660		3.06		
Dynamo en spanningsregelaar	460		A2		
Indtrapp en bobine, B18 FT			A53		
Elektrisch bedienbare zijruit, links			D8		
Elektrisch bedienbare zijruit, rechts	1390		D9		

## Componentenlijst alfabetisch

Component	Positie	Num- mer	Component	Positie	Num- mer
LCD verlichting, informatiecentrum	1080	4.33	Radio-antenne	1370	H25
Leeslamp, achterpassagier rechts	40	K8	Rechter koplamp, grootlicht	2010	A14
Leeslamp, achterpassagier links	40	K1	Rechter koplamp, dimlicht	1910	A13
Lichtschakelaar	1840	C14	Rechter mistlamp	1950	A19
Linker dagrijlicht	1880	A26	Rechter richtinglicht	1520	A18
Linker mistlamp	1950	A29	Rechter parkeerlicht	1860	A17
Linker richtinglicht	1510	A28	Rechter dagrijlicht	1890	A16
Linker parkeerlicht	1760	A27	Rechter verstraler	2050	A15
Linker verstraler	2050	A25	Regeleenheid, elektronische ontsteking		A52
Linker koplamp, grootlicht	2000	A24	Regelklep, stationair toerental		B11
Linker koplamp, dimlicht	1900	A23	Relais, AC (airconditioning)	610	3.05
Luchtdrukgever, inspuitsysteem		B8	Relais, antennemotor	1370	H29
Luchtmasa-meter, B18 F en FT		B14	Relais, contact 75	350	3.04
Luidspreker, LF	1340	F10	Relais, ventilatormotor, AC MAX	780	E6
Luidspreker, LF	1340	G10	Relais, ventilatormotor snelheid 1, AC	790	E5
MFU	1000	4.31	Relais, mistlampen(1988...)	1940	3.08
Mistachterlicht, links	1980	H18	Relais, hulpwaterpomp, B18 FT		3.16
Mistachterlicht, rechts	1980	H8	Relais, hulpwaterpomp, B18 E + F		3.15
Mistlampschakelaar	1930	C18	Relais, mistlampen (1987)	1940	3.02
Modulatieklep,		B13	Remlicht midden	1800	J3
uitlaatgas-recirculatiesysteem (EGR)			Remlicht, links	1780	H14,H15
motor schuif/kanteldak	1480	M3	Remlicht, rechts	1790	H4,H5
Motor, radio-antenne	1370	H24	Richtingaanwijzer, links achter	1510	H11
Motor, centrale vergrendeling	270	G4	Richtingaanwijzer, rechts	1520	H1
Motor, elektrische zijruit, portier passagier	1410	G2	Ruitesproeierpomp	1260	A10
Motor, elektrische zijruit, portier bestuurder	1410	F2	Ruitewisser-/wasschakelaar	1220	C8
Motor, kachelventilator	870	E1	Ruitewissermotor	1210	A46
Motor, linker koplamphuis	1630	A30	Schakelaar schuif/kanteldak	1470	M1
Motor, rechter koplamphuis	1700	A20	Schakelaar, waarschuwinglamp		L6
Motoren, achteruitkijkspiegel passagierszijde	1440	G5	ABS-systeem		
Motoren, achteruitkijkspiegel bestuurderszijde	1440	F5	Schakelaar, motorruimteverlichting		A8
Motorolie-temperatuurgever	1030	A43	Schakelaar kofferruimteverlichting	170	H21
Motorruimteverlichting	1590	A9	Schakelaar volgas	1250	H19
Motortoerentalgever		B4	Schakelaar achterklepslot	160	H22
Olie-drukgever + schakelaar	1160	A48	Schakelaar remlichten	1780	H9
Olie-niveaugever	1010	A40	Schakelaar, motorkapslot	1640	A47
Oliedrukmeter	1170	C32	Schakelaar, sleutelgat-verlichting	180	F6
Olieniveau + temperatuurgever	1010	A58	Schakelaar, centrale vergrendeling	270	F4
Olietemperatuur, informatiecentrum	1030	4.29	Schakelaar achteruitrijlichten	1330	A45
Ontstekingseenheid		A12	Schakelaar kachelventilator	840	E3
Ontstekingsrelais (contact 15)	310	3.03	Schakelaar handrem	950	D18
Ontwasemingsschakelaar, verwarming		5.03	Schakelaar, stoelverwarming passagier	390	D4
Pingelsensor		B10	Schakelaar, stoelverwarming bestuurder	370	D2
Pompmotor, ABS-systeem		L3	Schakelaar,	50	C30
Pomprelais, ABS-systeem		3.09	handschoenenkastverlichting		
Portierslotschakelaar, portier passagier	190	G3	Schakelaar mistachterlicht	1980	C16
Portierslotschakelaar, bestuurder	210	F3	Schakelaar achterrauitverwarming	110	C11
Potentiometer, CO-afstelling		B7	Schakelaar claxon	140	C10
Radio	1350	C25			

# Componentenlijst alfabetisch

Component	Positie	Num- mer	Component	Positie	Num- mer
Schakelaar achterrautsproeier	1280	C7	Verlichting, gordelsluiting passagier	590	D23
Schakelaar achterrautwisser	1300	C6	Verlichting, gordelsluiting bestuurder	570	D22
Schakelaar richtingaanwijzers	1510	C4	Verlichting asbak	1130	D21
Schakelaar waarschuwingslichten	1550	C3	Verlichting aansteker	1130	D12
Sleutelgat-verlichting	170	F7	Verlichting middenconsole schakelaars		D1
Smookklepschakelaar en klepstandsensoren, B18 FT		B18	Verlichting, lichtschakelaar		C34
Smookklepschakelaar, B18 E en B18 F		B9	Verlichting handschoenenkast	50	C31
Snelheidsgever, linker achterwiel, ABS		L10	Verlichting, centrale instrumentenpaneel		C29
Snelheidsgever, linker voorwiel, ABS		L9	Verlichting,	1560	
Snelheidsgever, rechter achterwiel, ABS		L8	waarschuwingknipperlichten		
Snelheidsgever, rechter voorwiel, ABS		L11	C28		
Snelheidsgever, eindaandrijving	1110	A44	Verlichting, contactslot	70	C27
Snelheidsmeter	1100	4.11	Verlichting, radio	1120	C26
Sperrelais, mistlampen (N)		3.12	Verstralers schakelaar	240	D6
sperrelais, gedimd-dimlicht (GB)		3.14	Verwarming carterventilatiesysteem, B18 F en FT		A51
Startmotor	420	A3	Verwarmingselement, achterraut	80	J1
Startonderbreking automaat		A62	Verwarmingselement, achteruitkijkspiegel	90	G1
Stoelverwarmingselement en thermostaat	390	D15	Vlotter ABS-vloeistofcontrole		L5
Stroomverdeler		A32	Vlotter sproeiervloeistofcontrole	940	A42
Stuureenheid, ABS-systeem		L1	Vlotter remvloeistofcontrole	930	A41
Stuureenheid (ECU), inspuitstelsel		B1	Voedingsrelais, ABS-systeem		3.10
Stuurrelais, inspuitstelsel		B2	Voorschakelweerstand, kachelventilator	840	E2
Systeem (hoge/lage)-drukschakelaar, AC	680	A35	Waarschuwinglamp, ABS-systeem		4.19
Systeemdrukschakelaar, ABS-systeem		L2	Waterslang-temperatuurschakelaar	1986	
Systeemventiel, ABS		L12	A37		
Tank brandstofmeter	960	D19	Wisselrelais, mistachterlampen (NL, N)	1970	3.07
Temperatuurgever, turbo-compressor B18 FT		A55	Zekering (naast B12), Brandstofpomp, B18 F en F		B20
Thermoschakelaar koelventilator, AC	650	A34	Zekering (naast B2), Zuurstofsensor, B18 F en FT		B19
Toerenteller		4.09	Zitcontact voorste passagiersstoel	580	D16
Turbo-laadrukregelklep, B18 FT		A54	Zuurstofsensor, B18 F en FT		B15
Uitlaatventiel, achterwielen, ABS		L17			
Uitlaatventiel, linker voorwiel, ABS		L16			
Uitlaatventiel, rechter voorwiel, ABS		L15			
Verdamper temperatuurschakelaar, AC	610	A31			
Verlichting, VEM		5.14			
Verlichting, kachelventilatorschakelaar	1130	E4			
Verlichting, instrumentenpaneel	1080	4.34			
Verlichting, keuzehendelpaneel, Automaat	1130	D24			

## Alfabetisch register

ABS systeem	102	VEM inhoud	121
Accuvolt- en oliedrukmeter	100	Verlichting achter met lamp-defectcontrole	44
Achterraut- en spiegelverwarming	112	Verlichting vóór met dagrijlichten	38
Achteruitrijlichten	58	Verlichting handschoenenkastje, motor, aansteker	64
Airconditioning	122	Verstralers	40
Automaat	32	Verwarming 5-standen (vanaf chassisnr. 513100)	120
Binnenverlichting	62	Verwarming 4-standen	118
Brandstofinspuiting, B18 FT	26	Voorstoelverwarming	116
Brandstofinspuiting, B18 F	24	Zekeringen overzicht	7
Brandstofinspuiting, B18 E	22		
Centrale vergrendeling	104		
Centrale verdeeldoos	4		
Claxon	108		
Componentenlijst vanaf	137		
Connectoren, vanaf	10		
Consoleklok	98		
Contactschakelaar	32		
Controlelamp "deur open" en zoemer verlichting	94		
Elektrisch bedienbare zijruiten	106		
Elektrisch instelbare spiegels	114		
Gebruiksaanwijzing voor de schema's	2		
Gedimd-dimlicht, grootlicht GB	42		
Grootlichtsignaal	40		
Handrem	92		
Hulpwaterpomp, B18 E en F	28		
Hulpwaterpomp, B18 FT	30		
Inbraakalarmsysteem	108		
Informatiecentrum, koelvloeistoftemperatuur	90		
Informatiecentrum, gemiddelde snelheid en buitentemperatuur	88		
Informatiecentrum, brandstofverbruik	86		
Informatiecentrum, olieniveau, olietemperatuur	82		
Informatiecentrum, brandstofmeter	84		
Instrument met informatiecentrum	79		
Instrument met informatiecentrum	78		
Instrument met informatiecentrum	77		
Instrument achterzijde	76		
Instrumentenverlichting	60		
Kabelbomen overzicht	8		
Koplampuismotoren	74		
Koplampsproeiers	70		
Laadstroom	92		
Massapunten overzicht	9		
Mistachterlichten, Euro	52		
Mistlampen voor en achter N en SF	56		
Mistlampen voor en achter NL	54		
Mistlampen, D, A	50		
Mistlampen, S, CH	48		
Mistlampen, Euro, GB	46		
Ontsteking en zuurstofsensor, B18 F motoren	36		
Ontsteking, B18 E motoren	34		
Oprijlaanverlichting	40		
Principeschema 1988-1989 vanaf	126		
Radio	124		
Relais overzicht	6		
Remvloeistof	92		
Richtingaanwijzers	66		
Ruitesproeiers	70		
Ruitewisser en sproeier achterraut	72		
Ruitewissers voorruit	68		
Schuifdak	110		
Sleutelgatverlichting	62		
Snelheidsmeter	80		
Sproeivloeistof	92		
Toerenteller	80		
Veiligheidsgordels	96		



## Terugrapporteringsformulier

Aan

Autodivisie Volvo Car B.V.  
Afd. Service Technical Support  
P.O. Box 1015  
5700 MC Helmond  
Nederland

Van

Betreft publikatie: .....

Hoofdgroep: .....

Pagina .....

TP-nr. ....

Voorstel/Motivering:

Datum .....

Heeft u opmerkingen of andere ideeën over dit boek? Maak dan van deze pagina een copie, schrijf uw ideeën op en stuur deze naar ons.

TP 35496/2  
1.200.7.89  
Dutch  
Printed in the  
Netherlands

Eindhoven Druk bv|Offset