



# SERVICE MANUAL

P 120

Part 2

CLUTCH

*Service Department*

AKTIEBOLAGET

**VOLVO**

GÖTEBORG SWEDEN

## CONTENTS

Description .....	1
Repair Instructions .....	1
Work which can be carried out with the clutch fitted .....	1
Removing .....	1
Replacing clutch facings .....	2
Main drive pinion guide bearing in the flywheel .....	3
Disassembling .....	3
Inspecting .....	3
Assembling .....	4
Dial indicating the flywheel .....	5
Dial indicating the flywheel housing .....	5
Fitting .....	5
Clutch control .....	6
Fault tracing .....	8
Tools .....	9
Specifications .....	10

## DESCRIPTION

The clutch is a single plate dry disc type of Borg and Beck manufacture. The pressure plate (22, Illustration 1) is operated by means of three levers (31) which are actuated from the clutch pedal (18) through the hydraulic clutch control. The thrust required on the pressure plate is obtained from six strong pressure springs (24). The release bearing (25) is guided by a tubular extension on the bear-

ing cover of the main drive pinion. The clutch is controlled hydraulically.

The control consists of a master cylinder (9) which is influenced by the clutch pedal and a control cylinder (41) on the flywheel housing (46) which operates the clutch via the clutch fork (33) and release bearing.

## REPAIR INSTRUCTIONS

### Work which can be carried out with the clutch fitted

#### Adjusting the clutch release fork travel and clutch pedal play

In order to prevent the clutch from slipping, the clutch fork travel (A, Fig. 1) must be checked and if necessary adjusted every 3000 miles (5000 km). In the event of trouble arising with declutching, the clutch pedal play (A, Fig. 2) should also be checked.

The clutch fork travel is adjusted by means of the nuts (1, Fig. 1). These are adjusted so that the clutch fork travel is 0.12"—0.16" (3—4 mm). The clutch pedal play should be 5 1/2" (140 mm) and is adjusted with the nut (1, Fig. 2).

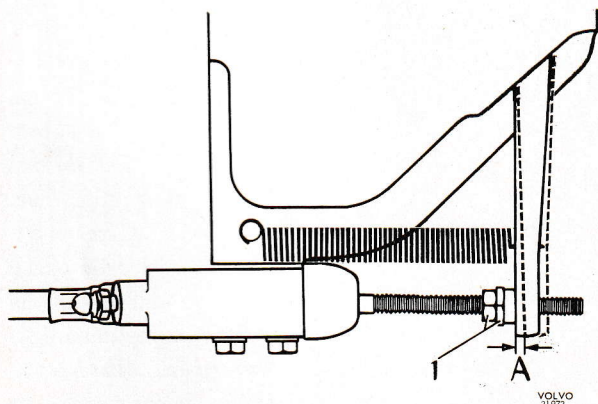

Fig. 1. Clutch fork travel

1. Adjusting nut      A. 0.12"—0.16" (3—4 mm)

### Clutch

#### Removing, early prod.

1. Remove the gearbox. Follow the instructions given in Part 3.
2. Disconnect the return spring.
3. Remove the release bearing.
4. Remove the cover under the flywheel.
5. Remove the release fork by first slackening the ball joint a few turns with a 17 mm spanner and then holding it still while unscrewing the bolt on which the ball joint fits. Then turn the release fork half a turn and remove it backwards.

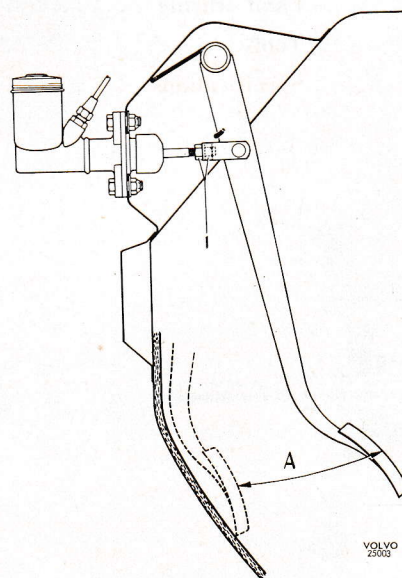

Fig. 2. Clutch pedal play

1. Adjusting nut      A. 5 1/2" (140 mm)

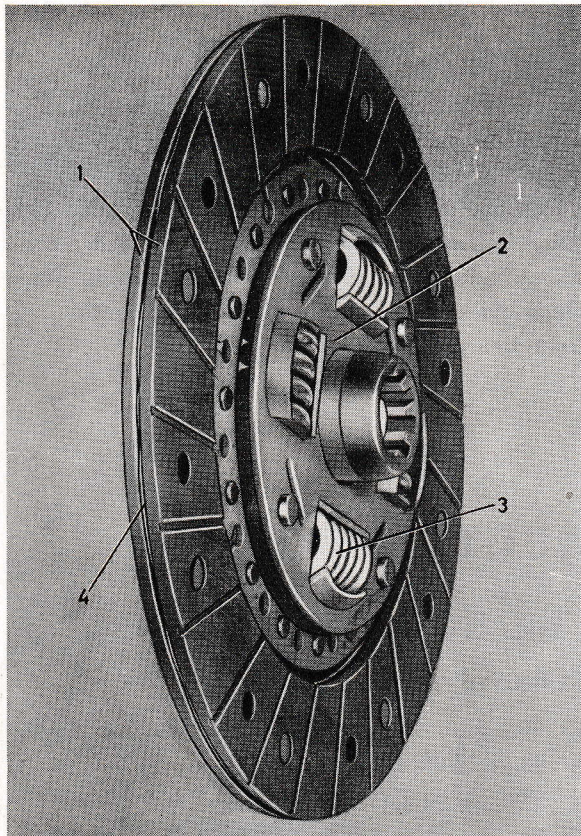

Fig. 3. Clutch plate

1. Facing    2. Hub    3. Spring    4. Disc
6. Check that the clutch and the flywheel are marked with paint. Otherwise, mark the clutch and flywheel with pressure plate with a centre punch. This must be done in order to ensure that the clutch is refitted in the same position as before.
7. The six bolts which hold the clutch to the flywheel should be slackened crosswise a couple

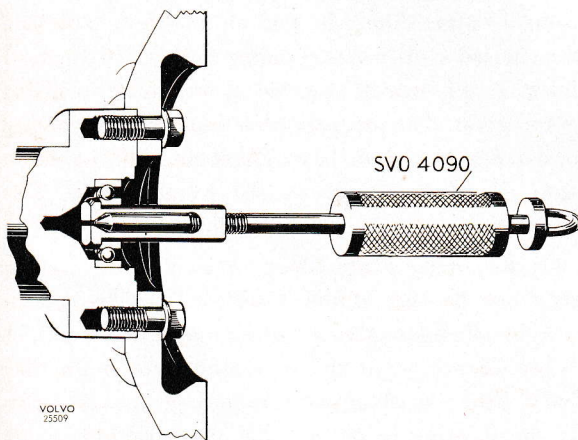

Fig. 4. Removing guide bearing

of turns at a time to prevent breakage and then removed. Hold up the clutch so that it does not fall to the floor. The clutch and the plate can then be removed downwards.

### Removing, late prod.

1. Remove the gearbox. Follow the instructions given in Part 3.
2. Disconnect the return spring (34, Illustration 1) at the release fork (33). Remove the bolt for the control cylinder (41). Tie up the cylinder to the body. Remove the plate from the lower front part of the flywheel housing (46). Remove the bolts and take off the flywheel housing.
3. Remove the release bearing (25). Unscrew the bolt which holds the ball joint for the release fork. Remove the ball and fork.
4. The six bolts which hold the clutch to the flywheel should be slackened crosswise a couple of turns at a time to prevent breakage and should then be removed. Hold up the clutch so that it does not fall to the floor. Lift off the clutch and clutch plate (23).

### Replacing clutch facings

1. Drill out the old rivets with a drill having the same diameter as the rivets, 9/64" (3.5 mm) and remove the old facings.
2. Check the clutch plate. The indentations should be even. The clutch plate must not be warped. The springs and rivets in the hub should fit securely and not show any signs of looseness. The plate should slide easily on the main drive pinion without any play. Check to see that there are no cracks. If any of these defects are found the clutch plate should be replaced with a new one.
3. Rivet on the new facings (preferably in a rivet press). Note. The rivets should be inserted from the side on which the facing lies and riveted from the opposite direction against the disc. Use every other hole in the facing. After riveting, the facings should be spaced from each other as determined by the indentations in the disc. See Fig. 3. This is most important in order to achieve a smooth engagement when starting and driving. The clutch facings must be absolutely free from oil. Oil on the facings can cause the clutch to chatter or grab.

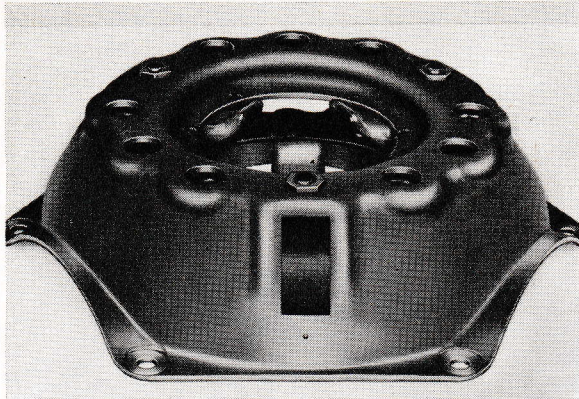

VOLVO  
20096

Fig. 5. Marking of clutch cover and pressure plate.

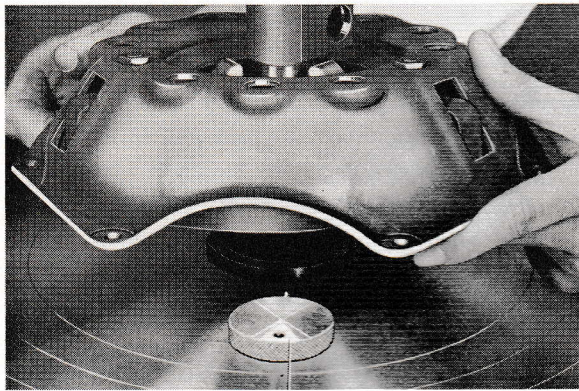

VOLVO  
24522

Fig. 6. Placing clutch in fixture, 1.

1. Packing block No. 0

### Main drive pinion guide bearing in the flywheel

The bearing is pulled out with puller SVO 4090 after the locking ring has been removed. See Fig. 4.

The bearing should be cleaned in gasoline. If the bearing, upon inspection, runs smoothly and evenly and has no significant play, it should be packed with ball bearing grease and refitted. Note. Heat-resistant grease should be used. The bearing is pressed in with drift SVO 1426.

### Disassembling

1. Mark the clutch as shown in Fig. 5.
2. Place the packing blocks No. 0 on fixture SVO 2322, see Fig. 6. Place on the clutch, the 3-point supports, the arms and the three thrust rods, see Fig. 7. Place on the wrench and press down the clutch until the housing contacts the bottom plate.

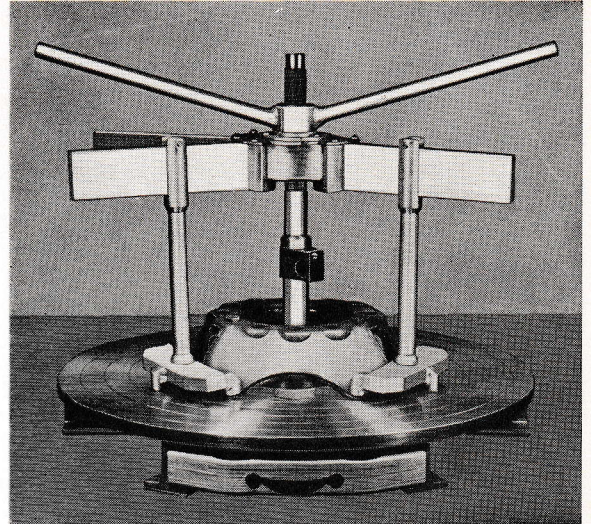

VOLVO  
24522

Fig. 7. Placing the clutch in the fixture, II.



VOLVO  
21109

Fig. 8. Removing the levers.

3. Screw off the three adjusting nuts for the clutch release levers (31).
4. Screw up the wrench and remove the arms and thrust rods. Remove the clutch cover casing (21).
5. Remove the levers as shown in Fig. 8.

### Inspecting

Examine the pressure plate for warping. The pressure plate should be laid on a surface table and then tested with a feeler gauge 0.006" (0.15 mm) thick. If this can be inserted at any point, warping is too great. The pressure plate must not be cracked or have a scored surface. There must be no scratches or other damage caused by the rivets. The same applies to the surface on the flywheel.

If the surfaces are blued or only lightly scored they can be reconditioned by grinding in a lathe with a saddle-mounted grinding machine, see Fig. 9. When carrying out this operation, not more than 0.03" (0.75 mm) of material may be ground away. If the damage is deeper, the parts should be replaced.

VOLVO  
20173

Fig. 9. Grinding the flywheel

The pressure springs should have the prescribed length, see the specifications.

The release bearing is checked by turning it round a few times under light pressure so that the balls rotate against the races. The bearing should turn easily without binding at any point. The release bearing should also slide easily on the guide extension from the transmission.

Note. During manufacture the release bearing is packed with lubricant which is intended to last the whole lifetime of the bearing. The bearing must therefore not be washed in gasoline or any other solvent, neither must it be warmed up to such an extent that the lubricant can run out. If the bearing is damaged or worn, it must be replaced by a new one. If it has become blued through having run round during driving, it should be replaced since the lubricant will have melted and run out.

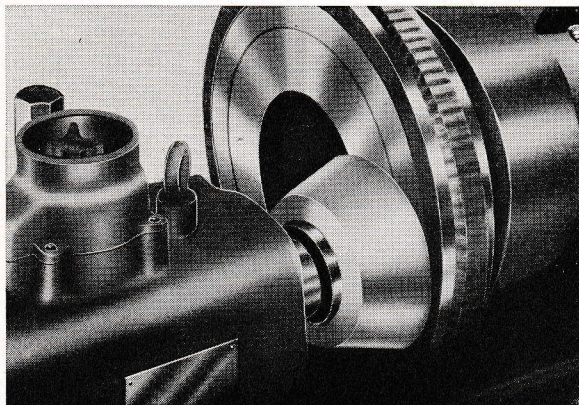
The release fork joint should be examined. The ball must not be worn or dry. The ball cup should be intact and the locking ring securely in position so that the fork cannot jump off the ball. Replace all parts which are worn or damaged. Lubricate the ball joint with grease when assembling.

Examine the clutch plate in accordance with point 2 under 'Replacing the clutch facings'.

### Assembling

1. Place the pressure plate (22) on packing blocks no. 0 in fixture SVO 2322.
2. Lubricate the contact surfaces of the clutch levers (31) with oil. Lubricate sparingly so that no oil can run down into the clutch plate after fitting.
3. Fit the clutch levers as shown in Fig. 8.

VOLVO  
20095

Fig. 10. Fitting the springs.

1. Springs for clutch levers

4. Place the six pressure springs (24) in position. (The springs should be arranged so that black ones and unpainted ones come alternately.)
5. Ensure that the three springs (1, Fig. 10) for the clutch levers are in position and place the clutch cover casing (21) over the six pressure springs in the position previously marked, Fig. 5.
6. Place on the 3-point support, arms, thrust rods and wrench. Press down the clutch cover casing until it contacts the bottom plate all round. Place the adjusting nuts on the eyebolts (32) and screw them on to full nut width. The clutch is now ready for adjusting.

### Adjusting the clutch levers

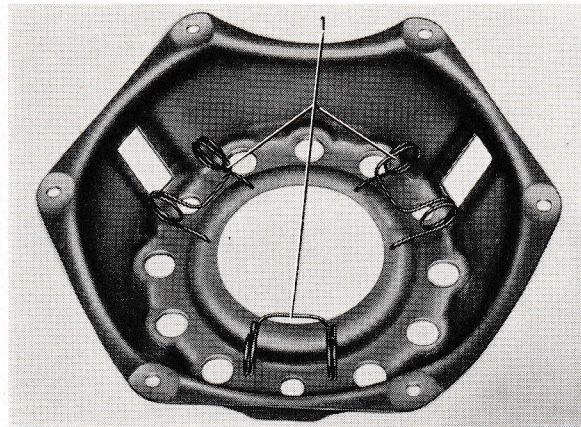
This adjustment is carried out in fixture SVO 2322 with the help of the measuring gauge kept in the compartment. Fit the gauge and arm in the attachment on the spindle and set the gauge to measurement 40.5 for 8" clutch and 41.5 for 8 1/2" clutch (adjusting surface at upper edge of arm). The foot of the measuring gauge is ground with tolerance positions corresponding to the mutual tolerance between the levers, see Fig. 11, and a side surface which is set parallel with the lever. Set the clutch lever to a height level with the maximum tolerance surface, see Fig. 12. The minimum tolerance surface must not then pass the edge of the clutch lever. Swing the arm when moving the measuring gauge over the clutch levers, see Fig. 13. After adjusting, carry out a further check on all the levers. Then secure the adjusting nuts by means of a centre punch, see Fig. 14. Remove the measuring gauge and arm before releasing the clutch.

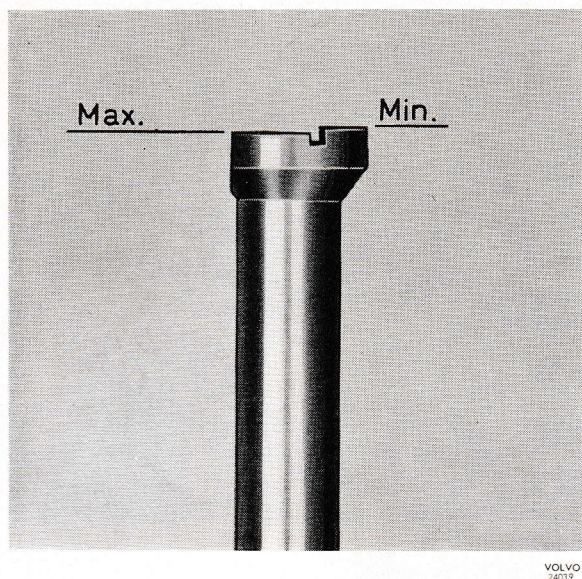

Fig. 11. Measuring gauge with tolerance positions.

Max. plan = Max. level  
Min. plan = Min. level

### Dial indicating the flywheel

When checking to see that the flywheel is not warped, a dial indicator gauge is applied with the help of a magnetic attachment on the cylinder block. The measuring point of the indicator is directed onto the face of the flywheel near the outer diameter. The crankshaft is rotated and the variations read off. Maximum permissible warp is 0.008" (0.20 mm).

### Dial indicating the flywheel housing

The flywheel housing is measured with a dial indicator gauge applied to the flywheel by means of a magnetic attachment.

Measurement is carried out partly to check that the face of the housing attached to the transmission is at right-angles to the crankshaft with a permissible deviation of max. 0.002" (0.05 mm) per 4" (100 mm) diameter and partly that the hole is concentric with the axis of rotation of the crankshaft with a max. permissible deviation of 0.006" (0.15 mm).

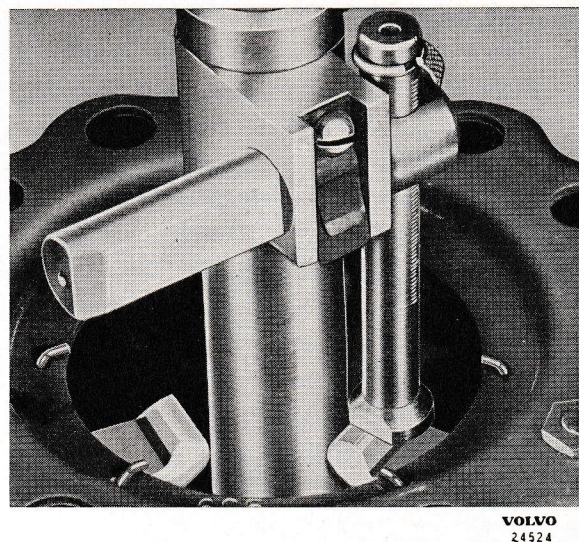

Fig. 12. Adjusting the clutch levers.

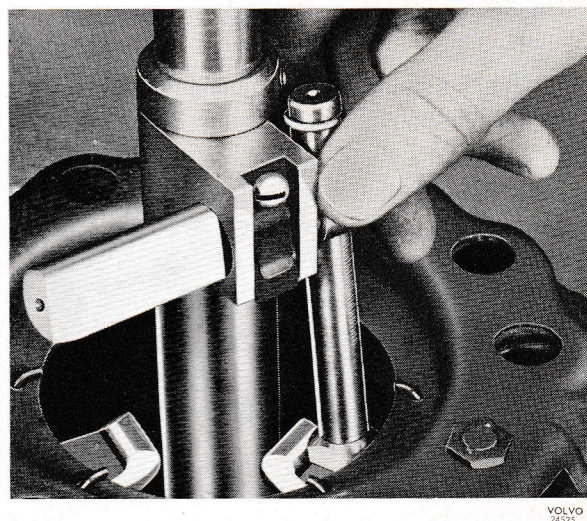

Fig. 13. Moving the measuring gauge.

### Fitting

Check before fitting that the clutch facings, flywheel and pressure plate are completely free from oil. Wash them with clean gasoline and dry off well with a clean piece of material.

#### Early production

1. Turn the flywheel so that the paint marking or the mark made when removing, becomes visible.
2. Set up the clutch plate (the highest side of the hub facing backwards) together with the clutch and insert the centring mandrel SVO 2484 so that the guide journal on this penetrates into the guide bearing in the flywheel.

3. Turn the clutch so that the mark on this coincides with the mark on the flywheel.
4. Place in the six bolts which retain the clutch and tighten them crosswise a couple of turns at a time. Remove the centring mandrel.
5. Fit the release fork by inserting it into the flywheel housing back to front and then turn it half a turn and secure the ball joint with the bolt.
6. Fit the release bearing.
7. Fit the linkage between the pedal and the release fork and fit on the return spring.
8. Fit the gearbox in accordance with the instructions in Part 3.
9. Bolt on the cover under the flywheel.

#### Late production

1. Set up the clutch plate (23) (the highest side of the hub facing backwards) together with the clutch and insert the centring mandrel SVO 2484 so that the guide projection on this enters the guide bearing in the flywheel.
2. Place in the six bolts which retain the clutch and tighten them crosswise a couple of turns at a time. Remove the centring mandrel.
3. Fit the release fork (33) in the flywheel housing (46) and secure the joint ball with the bolt.
4. Fit the flywheel housing and release bearing (25).
5. Fit the control cylinder (41) and hook on the return spring (34).
6. Fit the gearbox in accordance with the instructions given in Part 3.
7. Bolt the plate onto the lower front part of the flywheel housing.

## Clutch control

### Master cylinder

#### Removing

Remove the pipe (10, Illustration I) from the master cylinder (9). Remove the pedal bolt. Unscrew the bolts and lift off the cylinder.

#### Disassembling

1. Remove the cover and empty out the brake fluid.
2. Take off the rubber cover (16) and remove the locking ring (15). Take out the plunger (12) and the other parts from the cylinder.

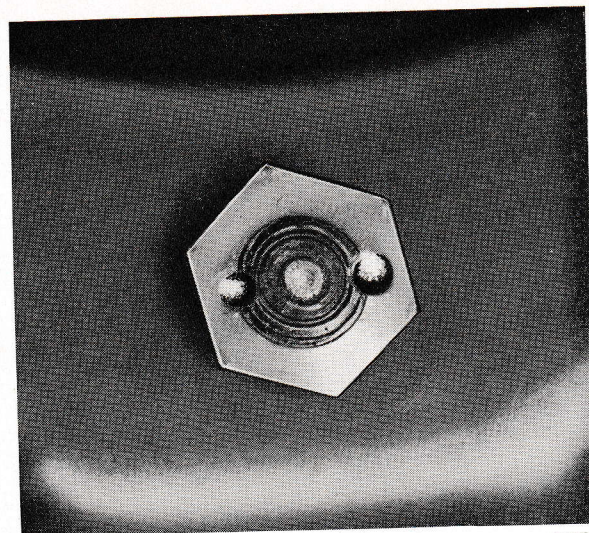

Fig. 14. Locking the adjusting nuts.

3. Remove the retainer (3) for the non-return valve (8) from the plunger and separate the parts.

#### Inspecting

Wash all parts in clean spirit and then check them for wear or other damage.

The cylinder must be carefully examined internally. There must be no grooves or scratches on the polished surface. Small scratches can be cleaned up with very fine emery cloth.

#### Assembling

1. Fit the packings on the plunger (12). Fit together the non-return valve (8), retainer (3), spring (5) and plunger.
2. Dip the plunger and non-return valve in brake fluid and fit them in the cylinders. Fit the thrust rod (17), washer (14) and locking ring (15). Place on the rubber cover (16).

#### Fitting

Fitting is done in the reverse order to removing. Fill up with brake fluid and bleed the system.

### Control cylinder

#### Removing

Remove the pipe (10) from the hose (40). Remove the hose from the retainer. Unhook the return spring (34). Remove the bolts and lift off the control cylinder (41).

### Disassembling

Remove the rubber cover (37) and thrust rod (35). Remove the locking ring (36) and take out the plunger (45) and spring (42).

### Assembling

Dip the plunger (45) and packing (44) in brake fluid and fit the packing on the plunger. Fit the spring (42) and plunger in the cylinder (41).

Fit the locking ring (36), thrust rod (35) and dust cover (37).

### Fitting

Fitting is done in the reverse order to removing. Bleed the system and adjust the clutch travel.

### Bleeding the hydraulic system

Check that the container is filled with brake fluid. Remove the rubber cap on the bleeding valve (43) on the control cylinder (41). Place a hose on the valve and immerse the other end of the hose in a container filled with brake fluid. Open the bleeding valve and depress the clutch pedal. Close the bleeding valve while the pedal is fully depressed. Then release the pedal. Repeat this procedure until brake fluid free from air bubbles runs out. Fill the container with brake fluid up to the level mark (fluid level).

### Renewing the pedal shaft

1. Remove the split pins and bolts in the pedals. Remove the return springs. Slacken the bolt and nut for the pedal shaft (8) Fig. 15. Remove the pedals (4,9) and shaft.

2. Knock out the bushings (3) with a suitable drift. Press in the new bushings.
3. Inspect the pedal shaft for wear. If it is abnormally worn, it should be replaced.
4. Lubricate the bushings in the pedal with a thin coating of ball bearing grease. Fit the spring and pedals on the pedal shaft and place them in position. Fit on the bolt and nut for the pedal shaft. Place in the pedal bolt and hook on the return spring.

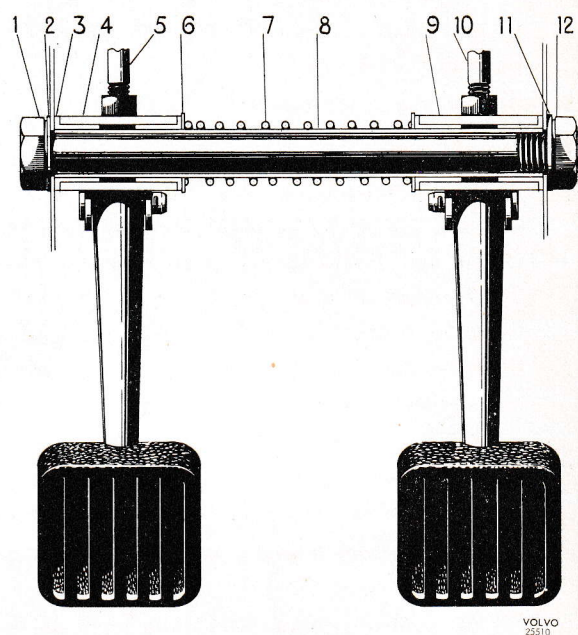

Fig. 15. Pedal shaft.

- |                  |                    |
|------------------|--------------------|
| 1. Bolt          | 7. Spring          |
| 2. Washer        | 8. Pedal shaft     |
| 3. Nylon bushing | 9. Brake pedal     |
| 4. Clutch pedal  | 10. Thrust rod     |
| 5. Thrust rod    | 11. Locking washer |
| 6. Washer        | 12. Nut            |

## FAULT TRACING

### Fault

Reason \_\_\_\_\_ Remedy

#### The clutch grabs

Clutch wrongly adjusted.	Follow the instructions under "Adjusting the clutch levers" and "Adjusting the clutch release fork travel and clutch pedal play".
Clutch plate warped.	Fit new clutch plate.
Oil on the clutch facings, flywheel or pressure plate.	Replace the facing. Clean the flywheel and pressure plate with clean gasoline.
Clutch facings glazed on the surface.	Fit new clutch facings.
Clutch plate binds on the shaft.	Clean and lubricate the hub and shaft sparingly. File off any burr. (Replace the main drive pinion if necessary.)
Surface of the pressure plate of flywheel is scratched, cracked or burnt.	Replace the pressure plate or flywheel (surfaces which are blued or only slightly scratched can be ground).
Engine loose in mountings.	Tighten the engine. Replace damaged engine mountings.
Clutch disc loose on the hub.	Fit new disc.
Clutch pedal binds.	Lubricate the pedal bushing.
Excessive play in the universal joint or rear axle gear.	Adjust or replace worn parts.

#### The clutch slips

Clutch wrongly adjusted.	Follow the instructions under "Adjusting the clutch release fork travel and clutch pedal play".
The clutch facings worn.	Fit new facings.
Clutch spring too weak or broken.	Check all the springs. Replace faulty springs with new ones.

#### The clutch does not disengage

Clutch wrongly adjusted.	Follow the instructions under "Adjusting the clutch release fork travel and clutch pedal play".
Faulty release bearing.	Fit new bearing.
Pressure plate cracked or warped.	Replace the pressure plate.
Clutch plate warped.	Fit new clutch plate.

#### Noisy clutch

Springs in the clutch plate hub broken or loose.	Replace clutch plate and facings.
Release bearing worn or dry.	Replace the bearing.
Bearing in the flywheel worn or not lubricated.	Replace or lubricate the bearing.
Clutch plate is loose at the hub.	Fit new clutch plate.
Broken clutch springs.	Replace the springs with new ones.

# TOOLS

For carrying out repairs on the clutch the tools shown below (Fig. 17) are required together with clutch fixture SVO 2322. (Fig. 16).

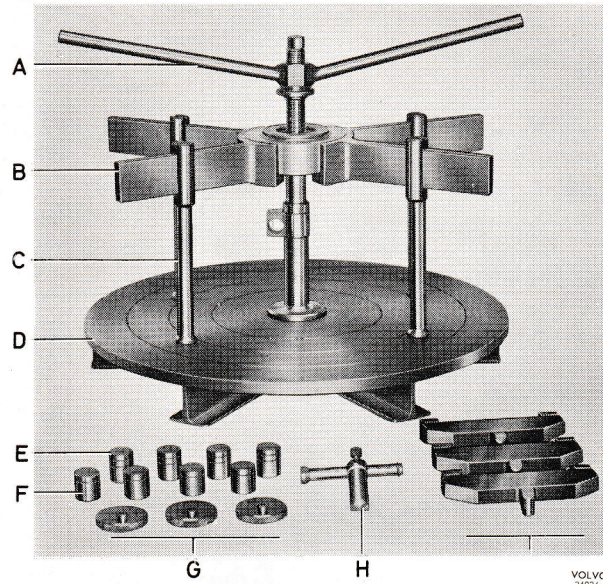

Fig. 16. Clutch fixture SVO 2322 with accessories.

- |                        |                                |
|------------------------|--------------------------------|
| A. Wrench              | F. Packing block No. 1         |
| B. Arm                 | G. Packing block No. 0         |
| C. Thrust rod          | H. Measuring gauge with holder |
| D. Bottom plate        | I. 3-point support             |
| E. Spacing block No. 2 |                                |

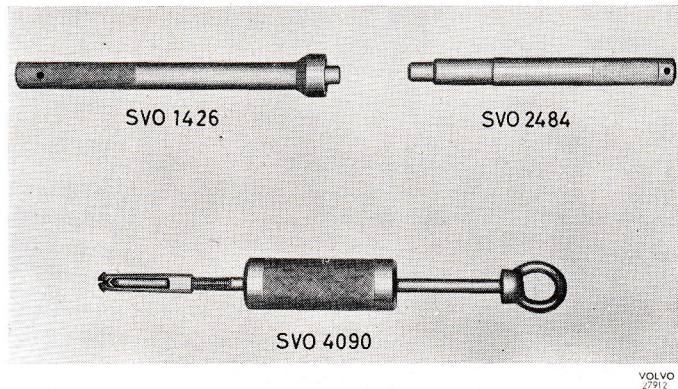

Fig. 17. Special tools.

- |          |                                       |
|----------|---------------------------------------|
| SVO 1426 | Drift for support bearing in flywheel |
| SVO 2484 | Mandrel for centring the clutch plate |
| SVO 4090 | Puller for ball bearing in flywheel   |

## SPECIFICATIONS

### For B 16

Type .....	Single dry disc
Size .....	8"
Friction area, total .....	340 cm <sup>2</sup> (52.7 sq. in.)
Thickness of clutch plate when fitted .....	7.0—7.5 mm (0.276—0.295")
Rivets for clutch facings:	
Number .....	16
Size .....	9/64" × 1/4" (3.5 × 6.5 mm)
Distance between the clutch release lever contact surface for the release bearing and flywheel .....	46 mm (1.81")
Clutch springs:	
B 16 A, early production and B 16 B:	
Colour: Neutral	
Length, loaded with 85.5—90.5 kg (188—199 lb.) .....	38 mm (1.496")
B 16 A, late production:	
Colour: Light yellow and light green	
Length, loaded with 82—86 kg (180—189 lb.) .....	40 mm (1.575")
Number .....	6
Adjusting the clutch release levers:	
Alternative I 7.5 mm (0.295") lower than the hub in adjusting jig SVO 2065 within a limit of ± 1.5 mm (0.06") and within 0.25 mm (0.010") of each other.	
Alternative II, adjustment 40.5 in clutch fixture SVO 2322, packing blocks number 0.	
Clutch fork free travel .....	3—4 mm (0.12—0.16")
Clutch pedal stroke .....	140 mm (5 1/2")
Tightening torque for bolt for joint ball .....	1.7—1.9 kgm (12—14 lb. ft.)

### For B 18

Type .....	Single dry disc
Size .....	8 1/2"
Friction area, total .....	440 cm <sup>2</sup> (68.2 sq. in.)
Clutch plate thickness when fitted .....	7.0—7.5 mm (0.276—0.295")
Rivets for clutch facings, number .....	16
Distance between the clutch release lever contact surface for the release bearing and flywheel .....	46 mm (1.81")
Clutch springs:	
Number .....	6
Marking .....	Neutral
Length, loaded with 85.5—90.5 kg (188—199 lb.) .....	38 mm (1.496")
Adjustment of clutch release levers:	
Adjustment 41.5 in clutch fixture SVO 2322, packing blocks number 0.	
Clutch fork free travel .....	3—4 mm (0.12—0.16")
Clutch pedal stroke .....	140 mm (5 1/2")
Tightening torque for bolt for joint ball .....	1.7—1.9 kgm (12—14 lb. ft.)

Illustration I. Clutch and clutch controls.

1. Shaft
2. Spacing spring
3. Retainer
4. Cover
5. Spring
6. Thrust rod
7. Retainer
8. Non-return valve
9. Master cylinder
10. Pipe
11. Plunger packing
12. Plunger
13. Plunger packing
14. Washer
15. Locking ring
16. Rubber cover
17. Thrust rod
18. Pedal
19. Return spring
20. Flywheel
21. Clutch cover casing
22. Pressure plate
23. Clutch plate
24. Clutch spring
25. Clutch release bearing
26. Clutch disc shaft  
(main drive pinion, gearbox)
27. Cover for clutch disc shaft
28. Spring
29. Shaft pin
30. Lip
31. Clutch release lever
32. Eyebolt
33. Clutch release fork
34. Return spring
35. Locknut
36. Adjusting nut
37. Thrust rod
38. Rubber cover
39. Locking ring
40. Hose
41. Control cylinder
42. Spring
43. Bleeding valve
44. Plunger packing
45. Plunger
46. Flywheel housing
47. Locking ring
48. Support bearing in crankshaft
49. Crankshaft

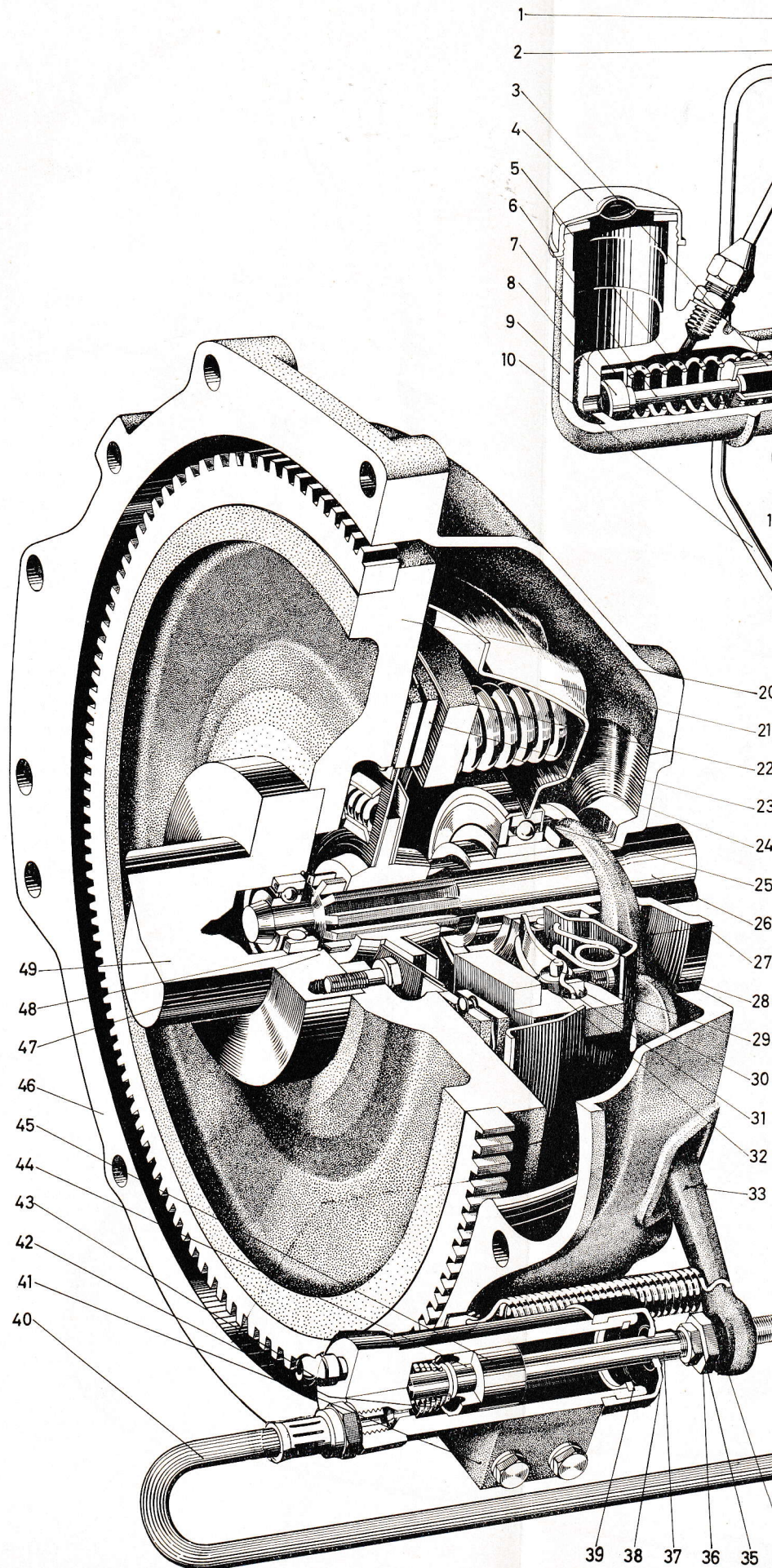

39 38 37 36 35

