

# Lucas

Catalog No. XIA116

## Fault Diagnosis Service Manual

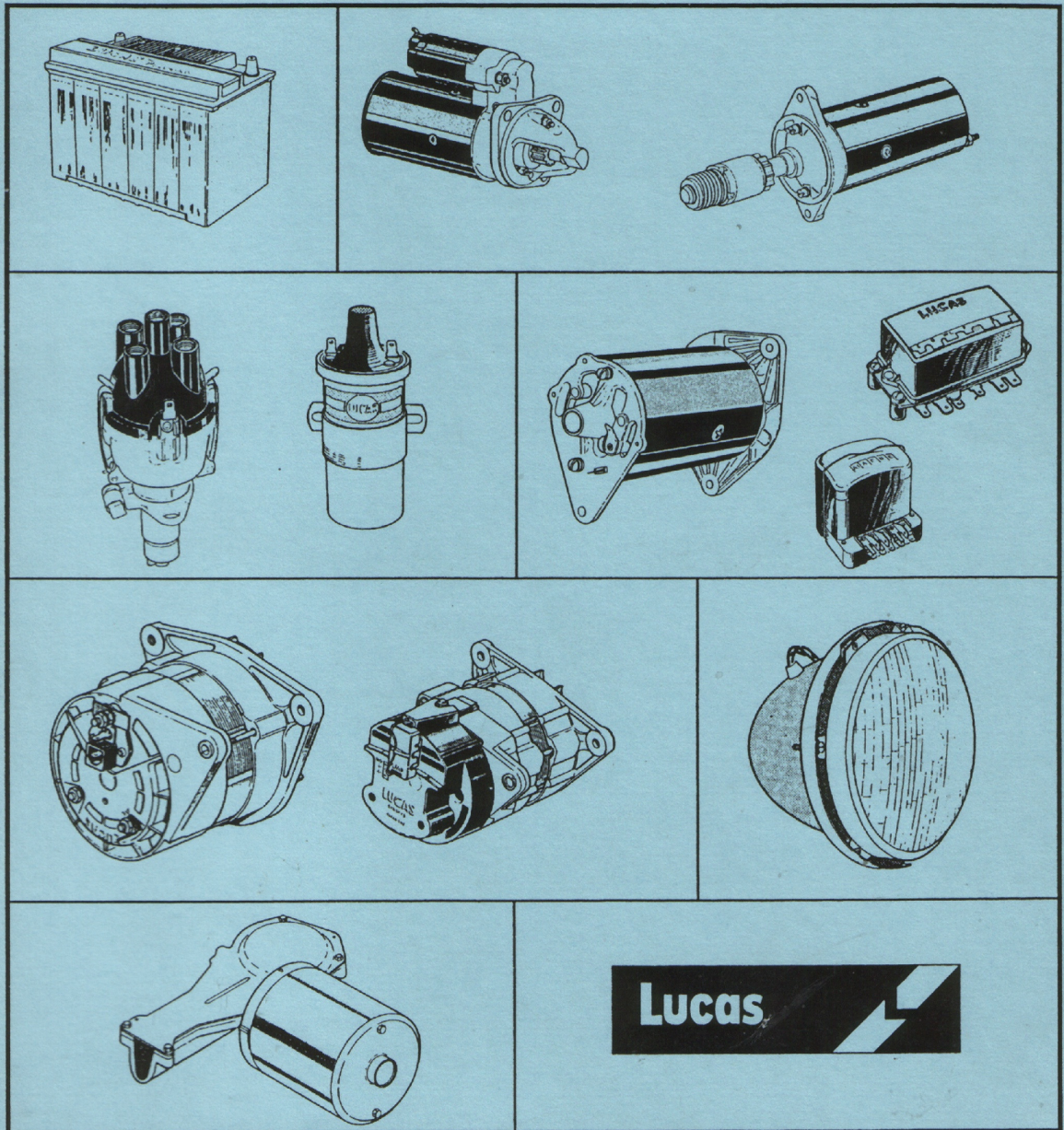

Contents

Introduction

# Fault Diagnosis Service Manual

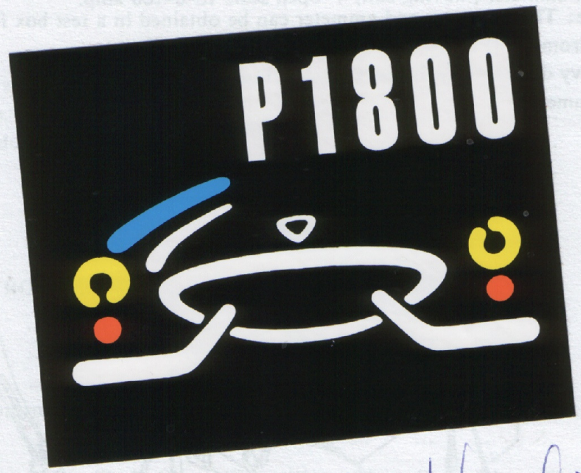

*Hilker Klubbverket*

Information contained herein has been carefully researched reliable sources. While all information is believed to be complete and accurate, we cannot accept responsibility for any error or omission. We reserve the right to make any necessary changes at any time, without notice. Should an error or omission be found, please report it immediately to the Lucas Aftermarket Operations Marketing Department.

# Introduction

Fault diagnosis is the method of locating faults while the electrical equipment is still in situ. In the interests of efficiency and economy, the diagnosis must be accurate and must be carried out in the shortest possible time using the minimum amount of equipment. It is the aim of this book to present a logical sequence of tests that may be carried out on the various sections of the equipment in order to achieve this objective.

The majority of procedures involve circuit testing and the principle used will be that of checking for "voltage drop" where a voltmeter is connected in parallel with the particular circuit to be tested.

As voltage drop exists only when current is flowing and varies according to the amount of current it is essential that the circuit is checked "under load", i.e. whilst passing its normal current. In certain instances this current will be measured using a test ammeter.

The acceptable volt drop figure for most circuits is 10% of system voltage (1-2 volts on a 12 volt system) but there are exceptions to this rule as in the case of the starter circuit where the maximum voltage drop allowed is 0-5 volts.

Throughout the procedures wherever an exception applies this figure will be clearly stated.

The following is the minimum equipment necessary to carry out this fault diagnosis:

1. D.C. voltmeter (moving coil) 4" open scale 0-40 volts.
2. D.C. ammeter (moving coil) 4" open scale 10-0-100 amp.

Note: The voltmeter and ammeter can be obtained in a test box form as shown.

3. Hydrometer (Fig. 1).
4. Heavy duty battery discharge tester (Fig. 2).
5. Ohmmeter.

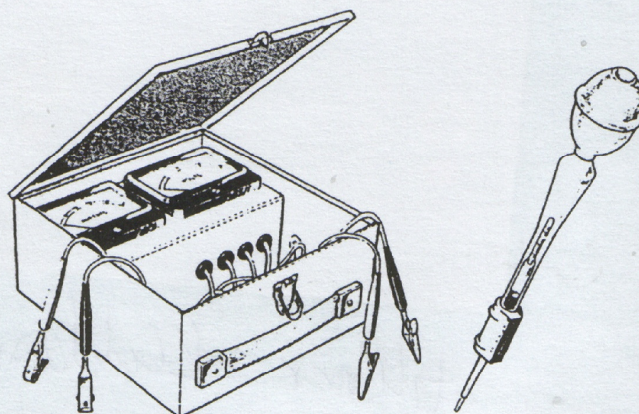

Fig. 1 Typical test box and hydrometer

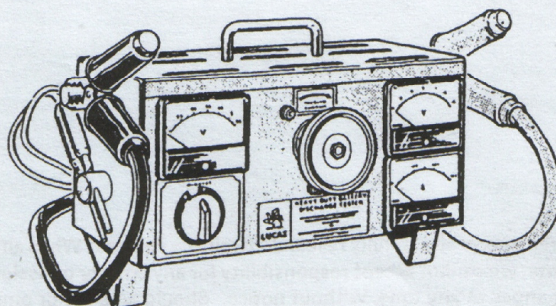
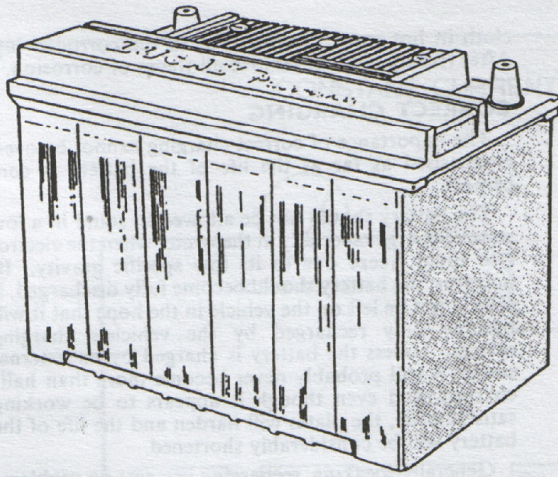

Fig. 2 Heavy duty battery discharge tester

# Contents

	Page(s)
INTRODUCTION ... ..	2
<b>BATTERIES</b> ... ..	<b>5 - 9</b>
<b>STARTERS</b> ... ..	<b>10 - 14</b>
Battery check ... ..	10
Checking the starter system (inertia drives) ... ..	10 - 11
Checking the starter system (pre-engaged drives) ... ..	12 - 14
<b>COIL IGNITION</b> ... ..	<b>15 - 25</b>
Standard coil ignition system ... ..	16 - 19
Ballasted ignition system ... ..	19 - 21
Opus ignition test procedure ... ..	22 - 24
Static ignition timing ... ..	25
Stroboscopic timing ... ..	25
<b>DYNAMOS AND CONTROL BOXES</b> ... ..	<b>26 - 30</b>
Battery test ... ..	26
Checking dynamo ... ..	26 - 27
Checking dynamo leads ... ..	27
Compensated voltage control ... ..	27 - 28
Ignition warning light ... ..	29
Current voltage control ... ..	29 - 30
<b>ALTERNATORS</b> ... ..	<b>31 - 37</b>
Battery test ... ..	32
10/11 AC systems ... ..	32 - 35
15/16/17/18/20ACR systems ... ..	36 - 37
Battery test ... ..	36
<b>LIGHTING</b> ... ..	<b>38 - 41</b>
Side and tail light circuit ... ..	39
Voltage at the battery under load ... ..	39
Headlights, stop lights and direction indicator circuits ... ..	39
Headlamp alignment ... ..	41
<b>WIPER MOTORS</b> ... ..	<b>42 - 44</b>
Wiper test procedure ... ..	42



# BATTERIES

## INTRODUCTION

The lead-acid battery is a device used to convert and store electrical energy in a chemical form and as the name implies the basic active materials are lead and sulphuric acid.

The purpose of the battery on the vehicle is primarily to provide current for the operation of the starter but it also supplies other equipment that may be used whilst the vehicle is stationary, e.g. radio, parking lights, etc.

During the course of normal running, the battery is recharged by the vehicle charging system and provided the vehicle does enough running time, will have stored energy ready for the next start operation.

**Note:** A vehicle standing idle will *not* maintain a charged battery.

As a battery fault can have adverse effects on the operation of the various systems, particularly the starting and charging system, some knowledge of battery testing is an essential part of fault diagnosis.

## BATTERIES IN SERVICE (Fig. 3)

1. **CLEAN AND DRY** – the battery, particularly the top must be kept clean and dry. Water spillage etc. during topping-up must be immediately wiped away.
2. **ELECTROLYTE LEVEL** – the electrolyte must be maintained at the correct height which is normally level with the tops of the separators or the splashguard.
3. **TOPPING-UP** – should be carried out when the electrolyte falls below the correct level. Only distilled water or de-ionised water must be added to replace electrolyte lost by evaporation.
4. **STATE OF CHARGE** – the battery must never be left in a discharged state. A battery in a poor state of charge i.e. less than 70% should be removed and charged from an independent source at the normal recharge rate. Otherwise the plates may become sulphated (hardened) making it difficult to accept

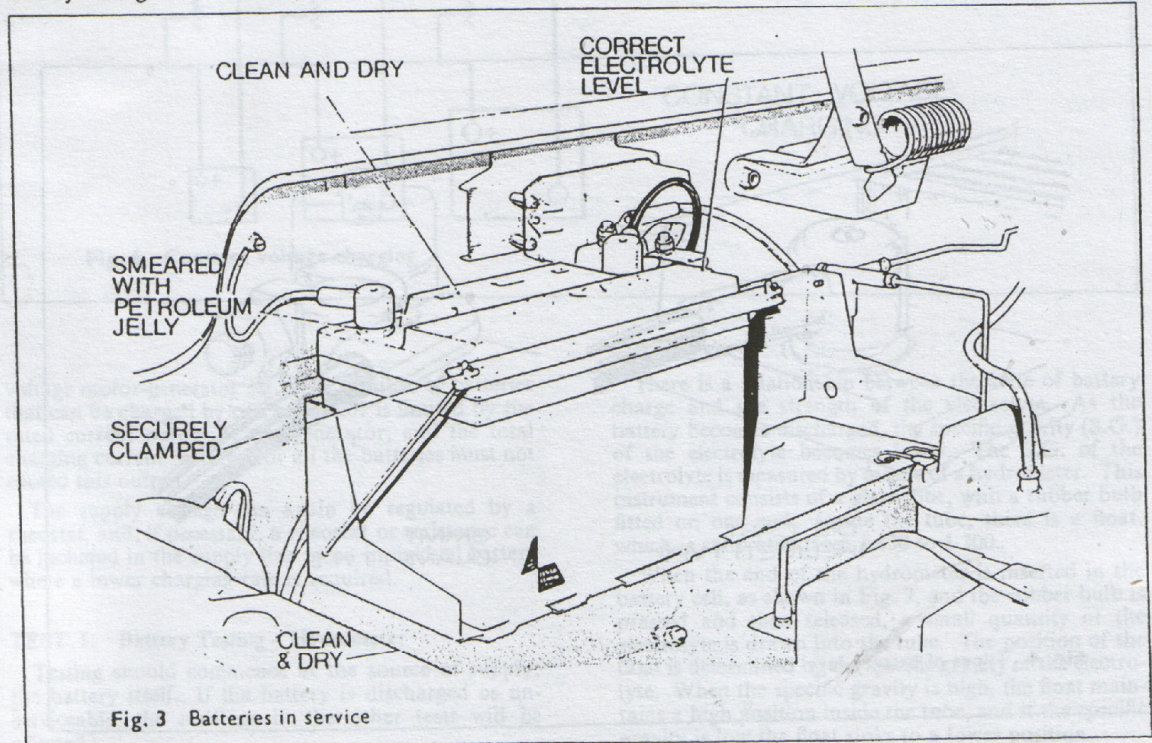

Fig. 3 Batteries in service

a charge, with the consequent early failure of the battery.

Ensure that the generator drive belt is adjusted correctly and that it does not rest on the bottom of the pulleys.

5. **INSTALLATION** – the battery must be securely clamped (not overtight) to prevent damage from vibration, which may cause shedding of active material from the plates resulting in a loss of capacity or short-circuit between the plates.

The stowage area must also be kept clean and dry. Any acid spillage should be removed with household ammonia or baking soda and hot water, otherwise the metal will be extensively damaged by corrosion. The metalwork should be repainted with acid-resisting paint after the corrosion has been neutralised.

#### **CARE OF BATTERY LUGS (Fig. 4)**

The effect of acid corrosion is far more serious than is generally realised. For example, excessive corrosion of the battery lugs will lead to sluggish operation of the starter. This is due to voltage drop at the battery terminals, when the high starter current is flowing.

The lead die-cast lug is designed to reduce the possibility of corrosion to a minimum and is fitted almost exclusively to British cars today.

The S.M.M.T. lug, clamp type, is used mainly on commercial and passenger vehicles.

In both cases the lug should be cleared of oxidation and the lug and battery post smeared with petroleum jelly as an added precaution against corrosion. When fitting the die-cast lug, ensure that it is in full contact with the terminal post by pressing it down firmly and securing it in position with the self-tapping screw. *Do not* use the screw to pull the lug down on to the terminal post.

Never use force when removing lugs. If, as a result of corrosion, a lug cannot be removed easily, soak a

cloth in hot water and apply it to the corroded lug. After freeing the lug, remove all traces of corrosion.

#### **CORRECT CHARGING**

The importance of correct charging cannot be over-emphasised as far as the life of the battery is concerned.

The battery should not be allowed to stand in a low state of charge especially in the winter when the electrolyte could freeze due to its low specific gravity. If, however, the battery should become fully discharged, it should not be left on the vehicle in the hope that it will become fully recharged by the vehicle's charging system. Unless the battery is charged by an external source it will probably never become more than half-charged, and even though it appears to be working satisfactorily, the plates will harden and the life of the battery will be considerably shortened.

Generally speaking, recharging presents no problems if the recharging rates quoted on the instruction labels are adhered to. The normal charge rate is approximately one-tenth of the A/H capacity of the battery at the 10 hour rate or 20 hour rate.

#### **CHARGING METHODS**

Either the constant current method, which we advocated for initial charging, or the constant voltage method may be employed for recharging. In either case a **DIRECT CURRENT** supply must be used. The connections to be made differ with the method and can be seen from the diagram. You will see that, using the constant current method (Fig. 5), the batteries are in series. Thus, a limit is set to the number of batteries that may be charged in series, since the voltage of the batteries when fully charged must not exceed the supply voltage. It is found in practice that the most suitable arrangement is ten 6 volt batteries or five 12 volt batteries when charging from a 110 volt supply.

With the constant voltage system (Fig. 6), the batteries are connected in parallel, usually to a low

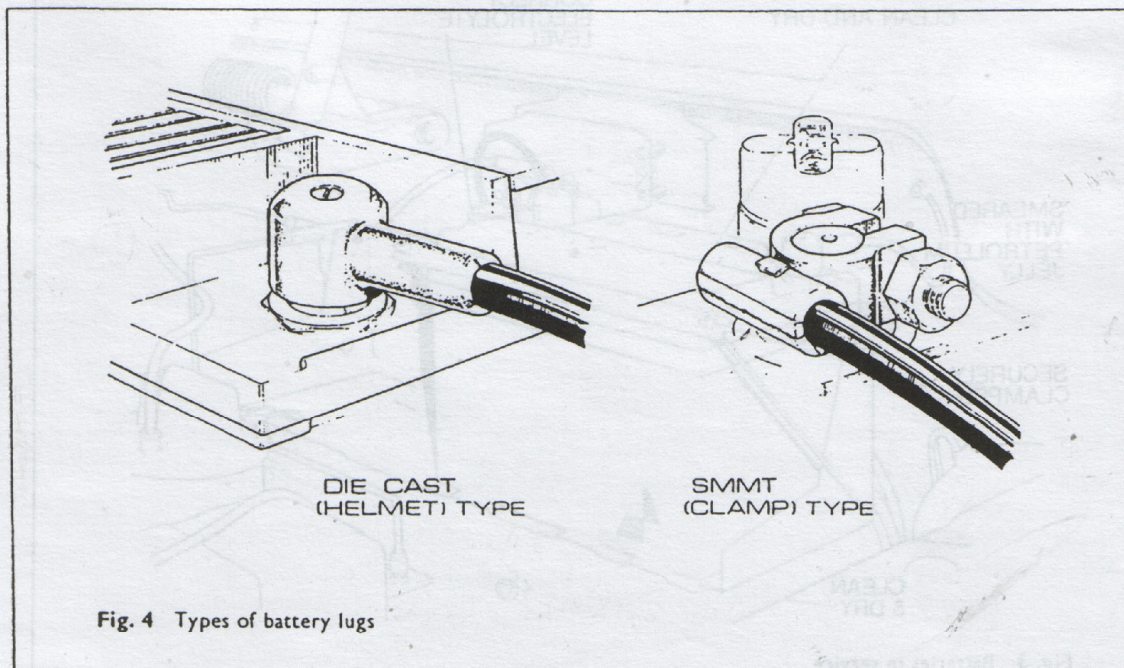

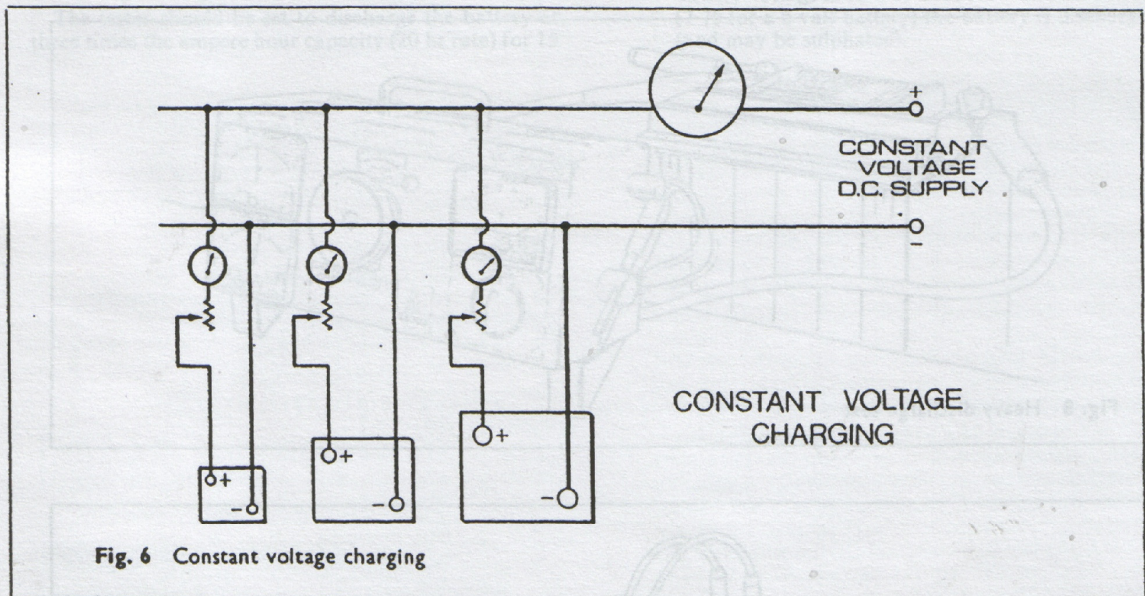
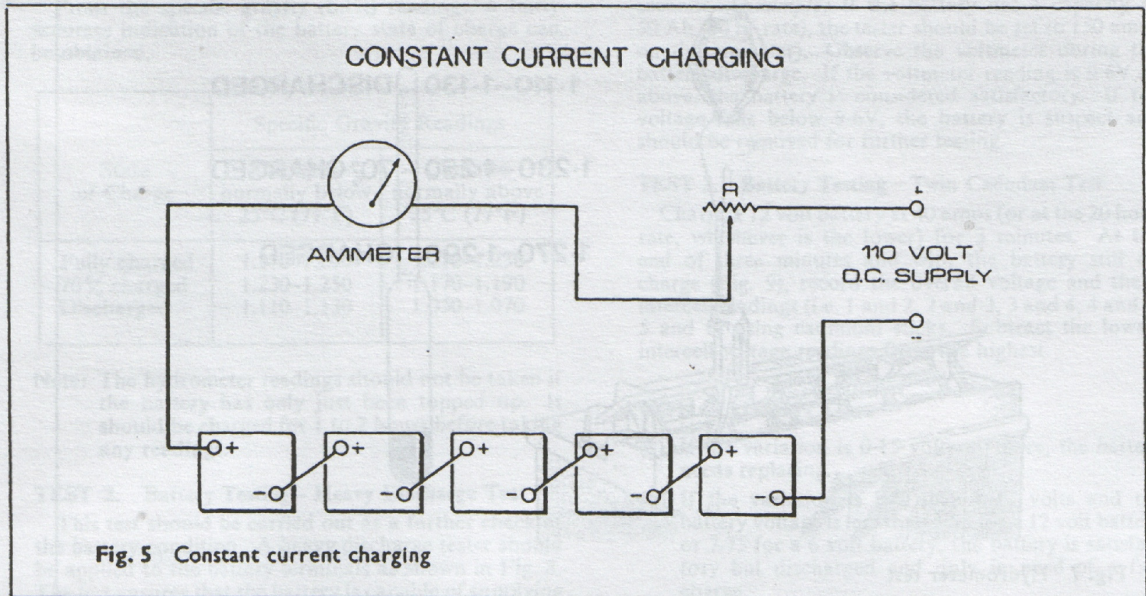

voltage motor-generator set. The number of batteries that can be charged by one generator is limited by the rated current output of the generator, and the total charging current required for all the batteries must not exceed this output.

The supply voltage can again be regulated by a rheostat, and, if necessary, a rheostat or resistance can be included in the supply line to an individual battery where a lower charging rate is required.

#### TEST 1. Battery Testing - Hydrometer

Testing should commence at the source of supply; the battery itself. If the battery is discharged or un-serviceable, the readings in the other tests will be affected.

There is a relationship between the state of battery charge and the strength of the electrolyte. As the battery becomes discharged, the specific gravity (S.G.) of the electrolyte becomes lower. The S.G. of the electrolyte is measured by means of a hydrometer. This instrument consists of a glass tube, with a rubber bulb fitted on one end. Inside the tube, there is a float, which is calibrated from 1.130 to 1.300.

When the end of the hydrometer is inserted in the battery cell, as shown in Fig. 7, and the rubber bulb is pressed and then released, a small quantity of the electrolyte is drawn into the tube. The position of the float is determined by the specific gravity of the electrolyte. When the specific gravity is high, the float maintains a high position inside the tube, and if the specific gravity is low the float sinks to a lower position.

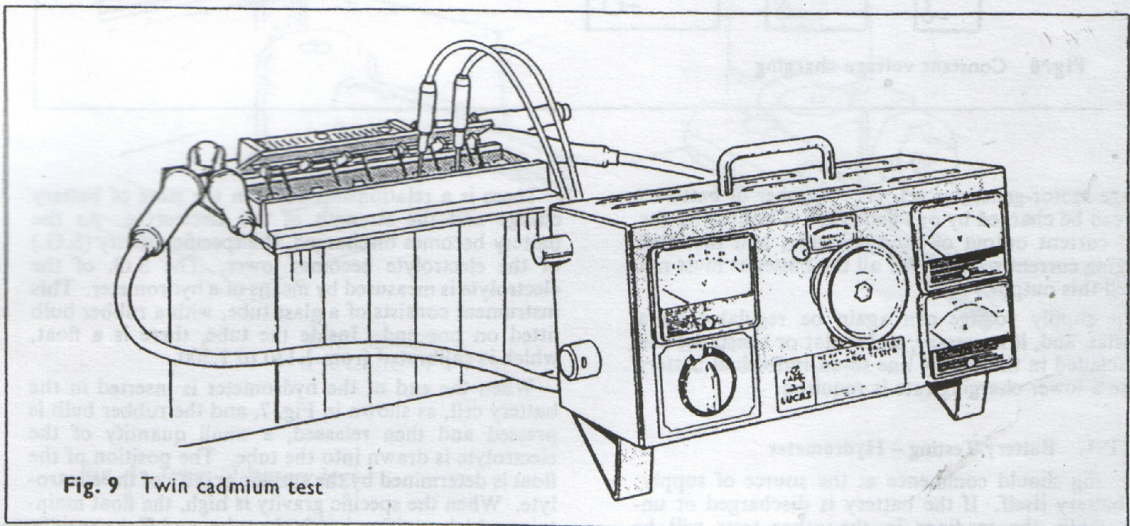
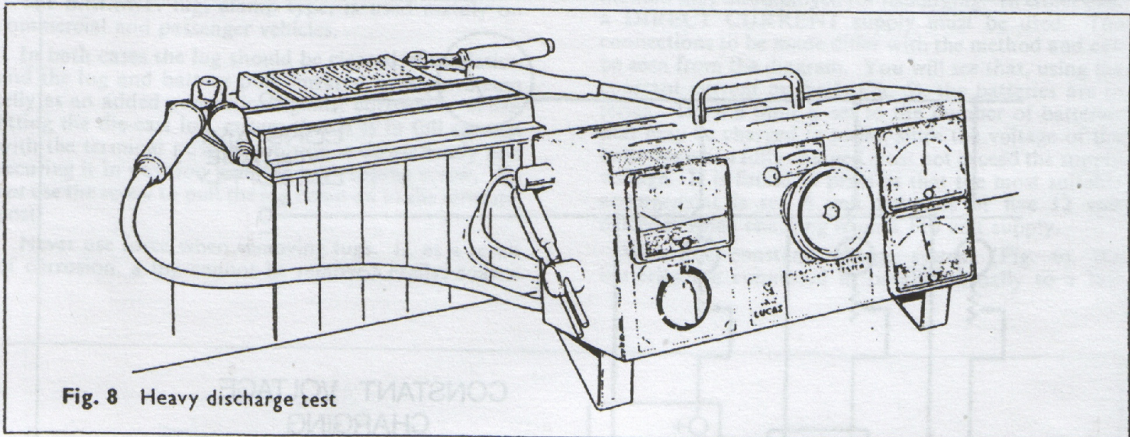
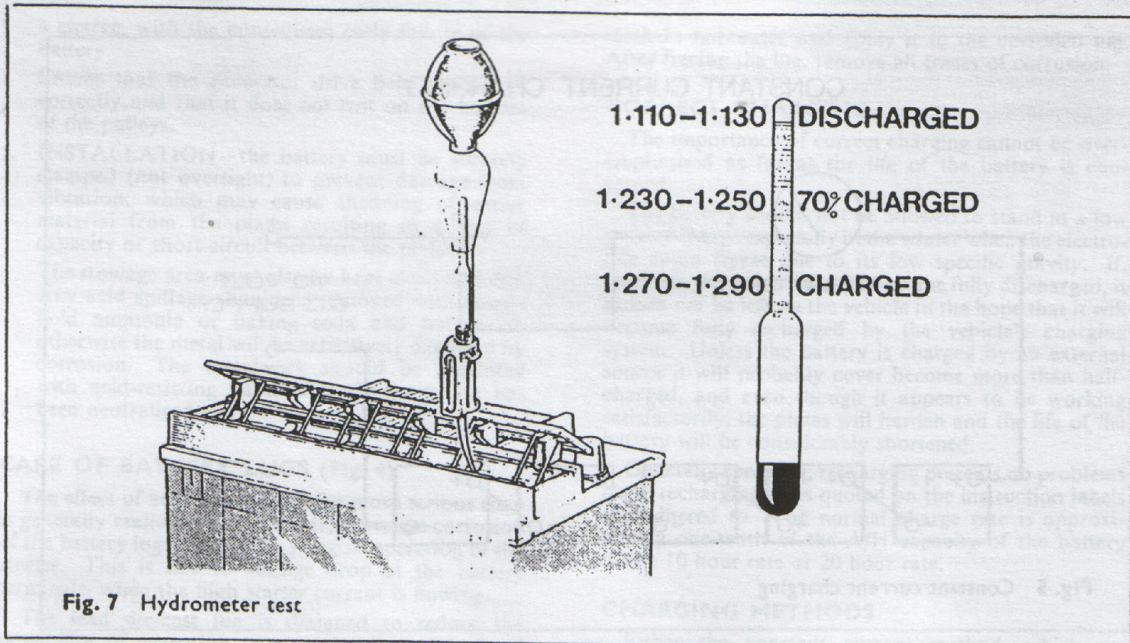

From the specific gravity (S.G.) readings, a fairly accurate indication of the battery state of charge can be obtained.

State of Charge	Specific Gravity Readings	
	Climates normally below 25°C (77°F)	Climates normally above 25°C (77°F)
Fully charged	1.270-1.290	1.210-1.230
70% charged	1.230-1.250	1.170-1.190
Discharged	1.110-1.130	1.050-1.070

**Note:** The hydrometer readings should not be taken if the battery has only just been topped up. It should be charged for 1 to 2 hours before taking any readings.

### TEST 2. Battery Testing - Heavy Discharge Test

This test should be carried out as a further check of the battery condition. A heavy discharge tester should be applied to the battery terminals as shown in Fig. 8. The test ensures that the battery is capable of supplying the heavy currents required by the starter at the moment of starting the engine.

The tester should be set to discharge the battery at three times the ampere hour capacity (20 hr rate) for 15

seconds. (Example: If the battery has a capacity of 50 Ah (20 hr rate), the tester should be set to 150 amps on the ammeter). Observe the voltmeter during the battery discharge. If the voltmeter reading is 9.6V or above, the battery is considered satisfactory. If the voltage falls below 9.6V, the battery is suspect and should be removed for further testing.

### TEST 3. Battery Testing - Twin Cadmium Test

Charge a 12 volt battery at 40 amps (or at the 20 hour rate, whichever is the lower) for 3 minutes. At the end of three minutes and with the battery still on charge (Fig. 9), record the overall voltage and the 5 intercell readings (i.e. 1 and 2, 2 and 3, 3 and 4, 4 and 5, 5 and 6) using cadmium sticks. Subtract the lowest intercell voltage readings from the highest.

### CONCLUSION

- (a) If the variation is 0.15 volts or more, the battery needs replacing.
- (b) If the variation is less than 0.15 volts and the battery voltage is less than 15.5 for a 12 volt battery or 7.75 for a 6 volt battery, the battery is satisfactory but discharged and only in need of a fast charge.
- (c) If the variation is less than 0.15 volts and the battery voltage is 15.5 or over for a 12 volt battery (7.75 for a 6 volt battery) the battery is discharged (and may be sulphated).

# STARTERS

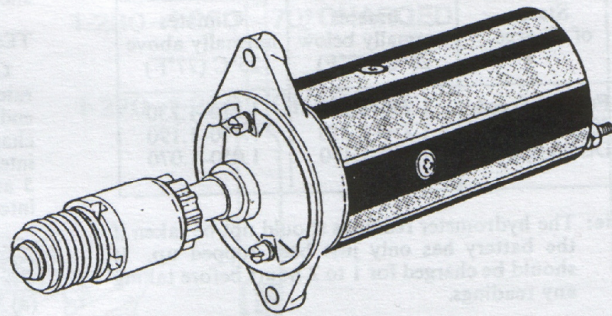
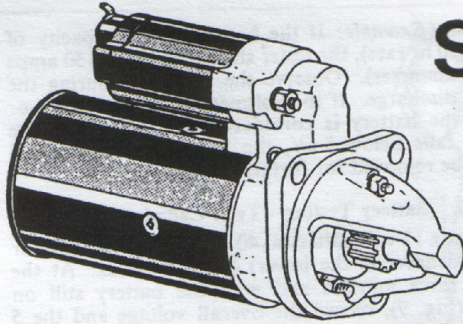

## INTRODUCTION

The starter is a motor which converts electrical energy, supplied from the battery, into mechanical energy for the purpose of cranking the engine.

There are two basic types of starter, the inertia type and the pre-engaged type, employing different methods of coupling the starter drive pinion to the engine flywheel ring gear.

*The inertia type* – used on the majority of cars and light commercials employing petrol engines. When the starter is energised rapid increase of speed at the armature and screwed sleeve, carrying the pinion, causes the pinion to move along the sleeve (due to its inertia) and engage the ring gear, thus rotary movement is transmitted to the engine, the ratio between the starter pinion and the ring gear, being approximately 10:1. When the engine fires and the flywheel accelerates to drive the pinion faster than the rotation of the armature, the pinion is ejected back along the screwed sleeve and consequently disengaged from the engine.

*The pre-engaged type* – used on heavier petrol engines but particularly suitable on diesel engines, where, due to intermittent firing characteristics and cranking speed surges (high compression) the pinion of the normal inertia type would be ejected prematurely.

By the operation of a solenoid the starter pinion is engaged with the flywheel ring gear before the starter is energised, after which the pinion can be retained in mesh for as long as is necessary to start the engine. When the engine is firing and the pinion being driven at high speed by the flywheel, the armature is protected against overspeeding by the freewheel action of a roller or plate clutch.

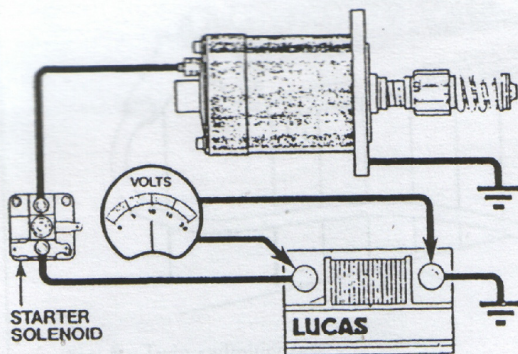

Fig. 10 Battery terminal voltage under load

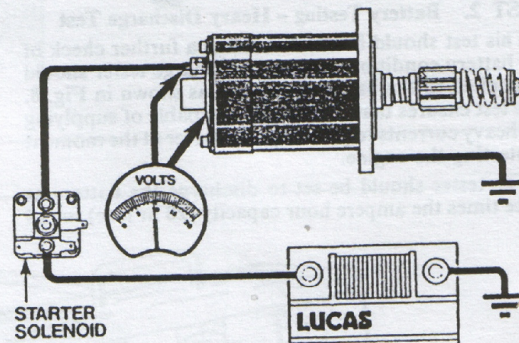

Fig. 11 Starter terminal voltage under load

## TEST 1. Battery Test

Using a hydrometer, check that the battery is at least 70% charged. The full battery test procedure is outlined in Section 1.

Note: A battery in poor condition will cause difficult starting.

## CHECKING THE STARTER SYSTEM (INERTIA DRIVES)

If the previous test has proved that the battery is satisfactory, a moving coil voltmeter (0–40V range) should be used to determine whether there is excessive voltage drop in the circuit.

Note: During the voltmeter checks, the starter should crank the engine, without starting it.

*Petrol engines:* The low-tension circuit of the ignition coil should be disconnected between the coil and distributor.

*Diesel engines:* Operate engine stop so that engine will not start.

## TEST 2. Checking the Battery Terminal Voltage under Load Conditions

This check enables the working voltage at the battery to be verified.

Fig. 10 shows a voltmeter connected between the positive and negative battery terminals.

The reading is noted when the starter switch is operated. The readings for a 12 volt system depends on the engine capacity, battery size (Ah) and type of starter. A typical figure for petrol engines is about 10.0 volts. Proceed to Test 3.

A low voltage reading would indicate excessive current in the circuit. The starter should be removed for bench testing.

**TEST 3. Checking the Starter Terminal Voltage under Load Conditions**

Having ascertained the battery voltage, the voltage across the starter is checked. Fig. 11 shows a voltmeter connected between the starter terminal and earth (commutator end bracket). When the starter operating switch is closed, the difference between this reading and that taken at the battery should not exceed 0.5V.

If the voltage drop is excessive proceed with the following tests.

**TEST 4. Checking the Voltage Drop on the Insulated Line**

For this test the voltmeter should be connected as shown in Fig. 12. The voltmeter is connected between the starter terminal and the battery supply terminal.

When the operating switch is open, the voltmeter should register battery voltage, but when the operating switch is closed the voltmeter reading should be noted.

**TEST 5. Checking the Voltage Drop across the Solenoid Contacts**

The solenoid contacts can be checked for voltage drop by connecting a voltmeter across the two main terminals as shown in Fig. 13. When the operating switch is open, the voltmeter should register battery voltage. When the operating switch is closed, the voltmeter reading should be noted.

**TEST 6. Checking the Voltage Drop on the Earth Line**

To check the voltage drop on the earth line, connect the voltmeter between the battery earth terminal and the starter earth (commutator end bracket), as shown in Fig. 14. When starter operating switch is closed the voltage reading should be practically zero.

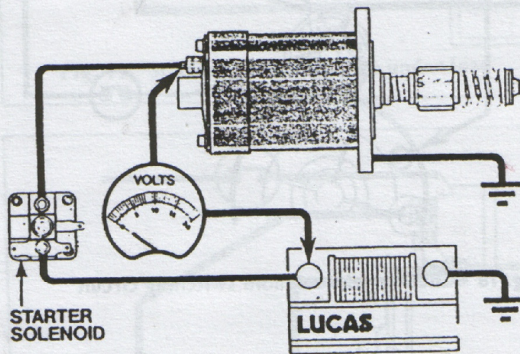

Fig. 12 Voltage drop on the insulated line

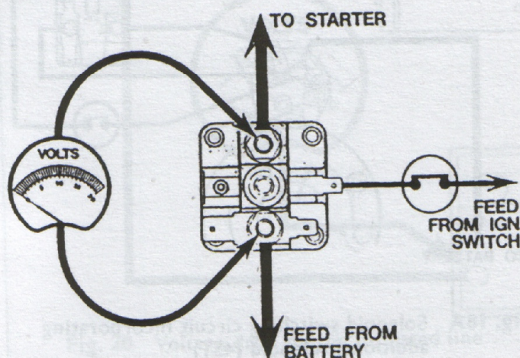

Fig. 13 Voltage drop across the solenoid contacts

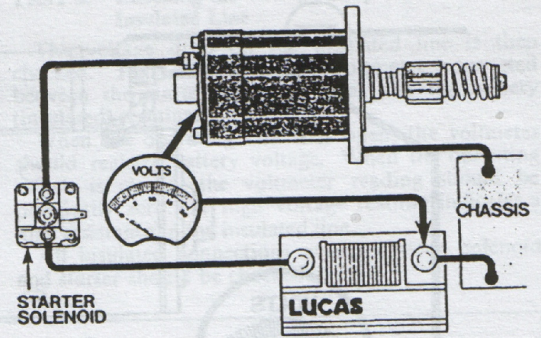

Fig. 14 Voltage drop on the earth line

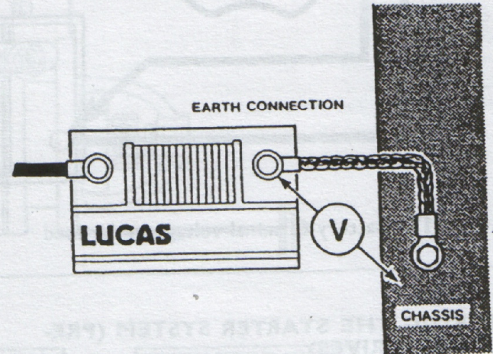

Fig. 15 Checking the earth connections

**TEST 7. Checking Earth Connections**

Connect the voltmeter between the chassis of the vehicle and the battery earth terminal (Fig. 15). Operate the starter. Once again note the reading.

**TEST 8. Checking Bonding Strap (Fig. 16)**

As most vehicle engines are rubber mounted, the bonding strap must make a good electrical connection between the engine block and the chassis. The units mounted on the engine block (i.e. distributor, dynamo and starter) must have an efficient earth connection in order to function correctly.

If the bonding strap is incorrectly fitted or frayed, it will have a serious effect on the performance of the starter, and may even immobilise the vehicle.

**Note:** The total voltage drop on the starter installation must not exceed 0.5V.

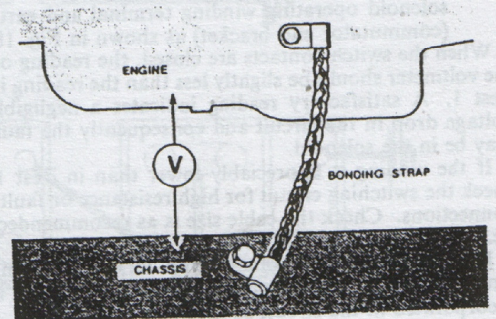

Fig. 16 Checking the bonding strap

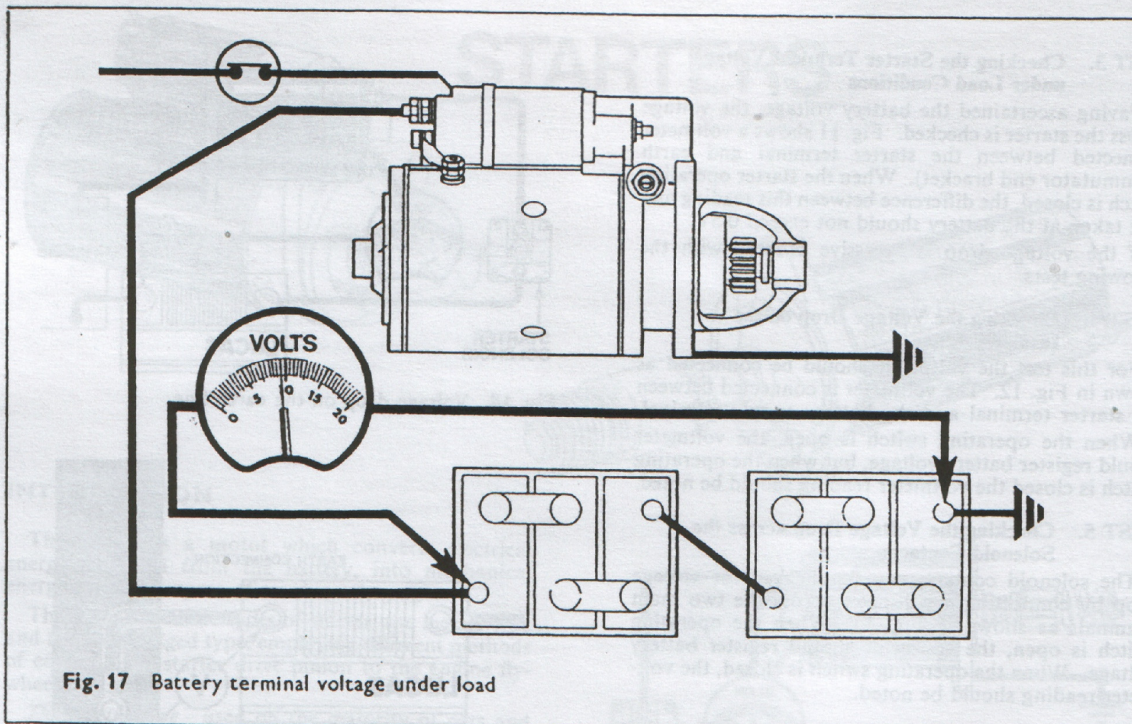

Fig. 17 Battery terminal voltage under load

### CHECKING THE STARTER SYSTEM (PRE-ENGAGED DRIVES)

The procedure for checking for excessive voltage drop in the pre-engaged starter circuit is similar to that used for inertia drive starter systems but in addition, the voltage available at the solenoid feed terminal must be checked. The complete procedure is as follows:

#### TEST 1. Checking the Battery Terminal Voltage under Load Conditions

Connect the voltmeter across the terminals, as shown in Fig. 17 and operate the starter switch. The readings for a 12 volt system depend on the engine capacity, battery size (Ah) and type of starter. A typical figure for petrol engines is about 10.0V, and for diesel engine (12V system), 9.0V.

A low voltage reading would indicate excessive current flow in the circuit. The starter should then be removed for bench testing.

**Note:** If the solenoid operates intermittently during the test or the engine is cranked at a low or irregular speed, there may be insufficient voltage at the solenoid operating winding terminal or the solenoid is faulty.

To check the switching circuit for high resistance, connect the voltmeter between the solenoid operating winding terminal and earth (commutator end bracket) as shown in Fig. 18.

When the switch contacts are closed, the reading on the voltmeter should be slightly less than the reading in Test 1. A satisfactory reading indicates a negligible voltage drop in the circuit and consequently the fault may be in the solenoid.

If the reading is appreciably lower than in Test 1, check the switching circuit for high resistance or faulty connections. Check the cable size is as recommended, i.e. 28/0.30 mm (28/012").

In order to reduce voltage drop in the switching circuit on some vehicle applications a 4ST solenoid is incorporated in the circuit as shown in Fig. 18a.

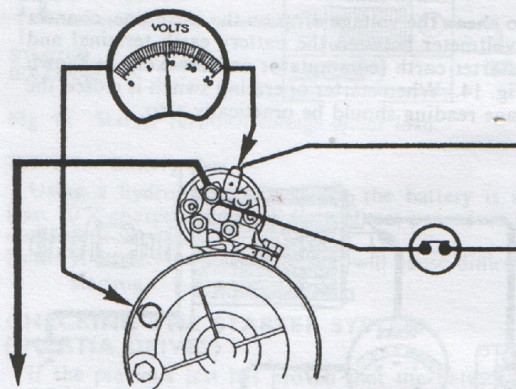

Fig. 18 Checking the solenoid switching circuit

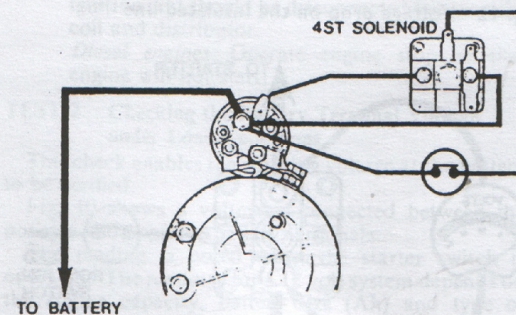

Fig. 18A Solenoid switching circuit incorporating additional solenoid (4ST)

**TEST 2. Checking the Starter Terminal Voltage under Load Conditions**

Having ascertained the battery voltage under load, the voltage across the starter is checked. Fig. 19 shows a voltmeter connected between the starter input terminal and earth (commutator end bracket). When the operating switch is closed, the difference between this reading and that taken at the battery should not exceed 0.5V.

If the reading is within this limit, the starter circuit is satisfactory. If there is a low reading across the starter, but the voltage at the battery is satisfactory, it indicates a high resistance in the starter circuit.

**TEST 3. Checking the Voltage Drop on the Insulated Line**

The voltage drop on the insulated line is then checked. Fig. 20 shows the voltmeter connected between the starter input terminal and the battery (insulated) terminal.

When the operating switch is open, the voltmeter should register battery voltage. When the operating switch is closed, the voltmeter reading should be practically zero. A high voltage reading indicates a high resistance in the insulated line.

All insulated connections at the battery, solenoid and starter should be checked.

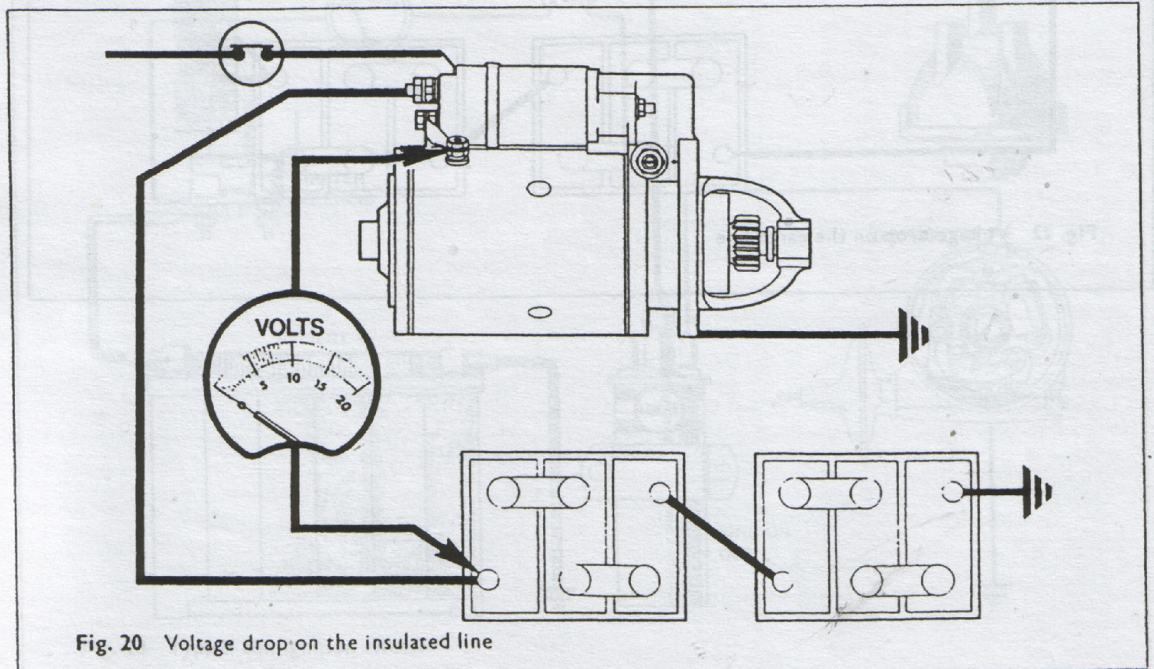
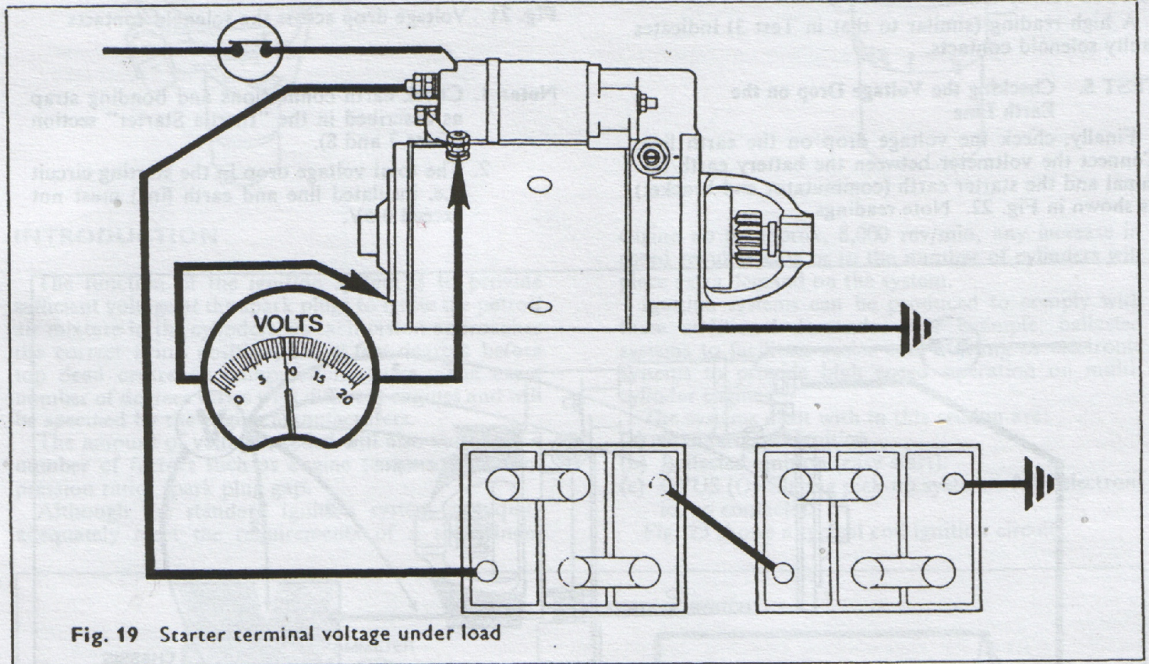

If all connections are in order, the starter solenoid contacts must be checked. (Proceed to Test 4).

**TEST 4. Checking the Voltage Drop across the Solenoid Contacts**

To check the voltage drop across the solenoid contacts, connect the voltmeter across the two main solenoid terminals, as shown in Fig. 21. When the operating switch is open, the voltmeter should register battery voltage. When the operating switch is closed, the voltmeter reading should fall to a fractional value.

A zero or fractional reading on the voltmeter indicates that the high resistance deduced in Test 3 must be due either to high resistance starter cables or soldered connections.

A high reading (similar to that in Test 3) indicates faulty solenoid contacts.

**TEST 5. Checking the Voltage Drop on the Earth Line**

Finally, check the voltage drop on the earth line. Connect the voltmeter between the battery earth terminal and the starter earth (commutator end bracket) as shown in Fig. 22. Note readings.

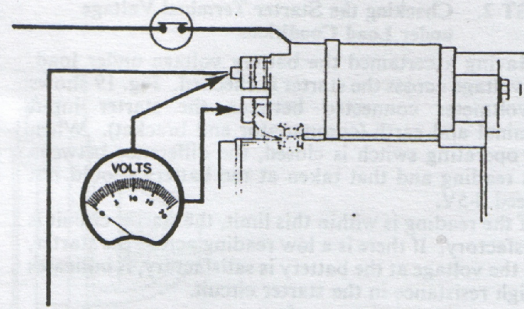

Fig. 21 Voltage drop across the solenoid contacts

- Note: 1. Check earth connections and bonding strap as described in the "Inertia Starter" section (Tests 7 and 8).  
 2. The total voltage drop in the starting circuit (i.e. insulated line and earth line) must not exceed 0.5V.

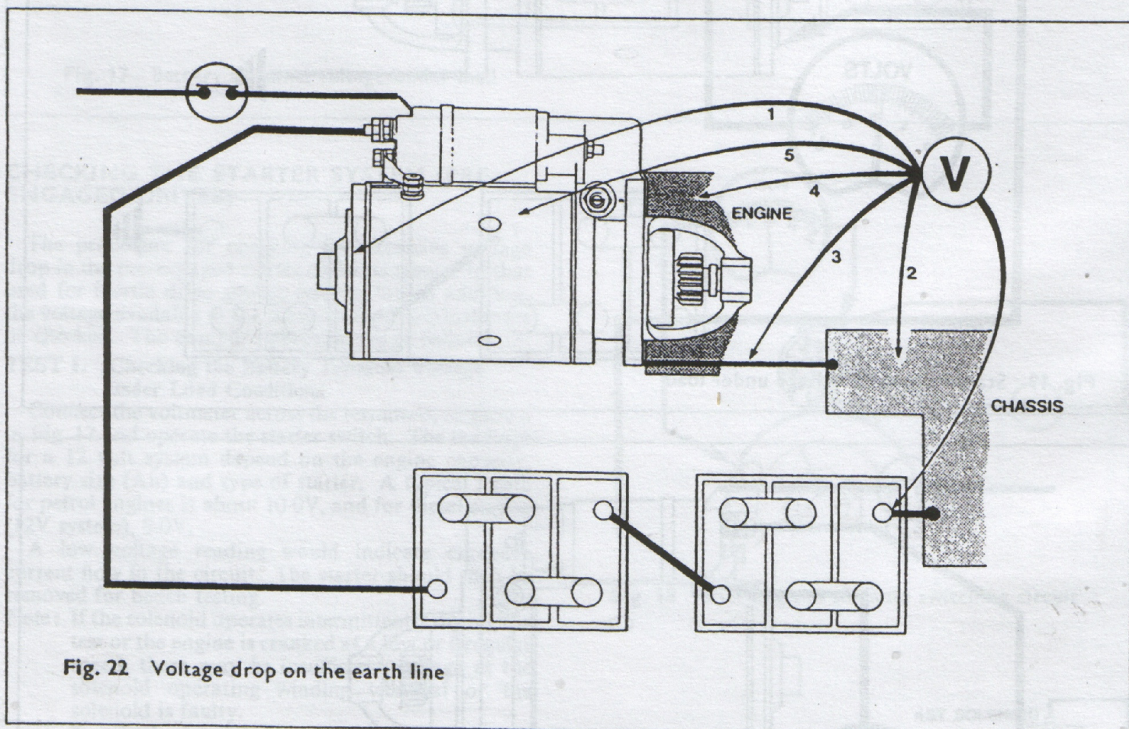
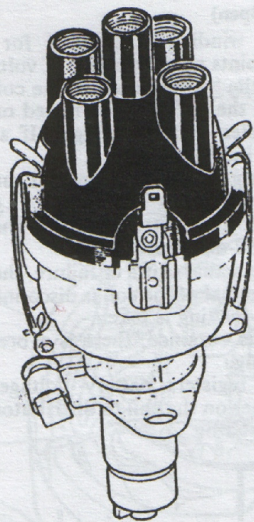
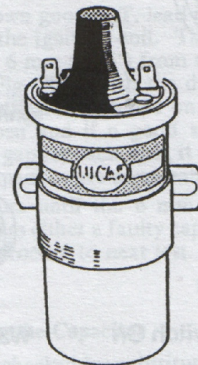

Fig. 22 Voltage drop on the earth line



# COIL IGNITION



## INTRODUCTION

The function of the ignition system is to provide sufficient voltage at the spark plugs to ignite the petrol/air mixture in the cylinders, as each piston approaches the correct firing position, i.e. a few degrees before top dead centre on compression stroke. The exact number of degrees varies with different engines and will be specified by the engine manufacturers.

The amount of voltage needed will also vary with a number of factors such as engine temperature, compression ratio, spark plug gap.

Although the standard ignition system will quite adequately meet the requirements of a six-cylinder

engine up to approx. 8,000 rev/min, any increase in speed requirements or in the number of cylinders will place extra demand on the system.

Ignition systems can be produced to comply with these additional demands. For example, ballasted systems to facilitate easier cold starting or electronic systems to provide high speed operation on multi-cylinder engines.

The systems dealt with in this section are:

- (a) Standard coil ignition.
- (b) Ballasted ignition (easy start).
- (c) OPUS (Oscillating pick-up system - fully electronic, no contacts).

Fig. 23 shows a typical coil ignition circuit.

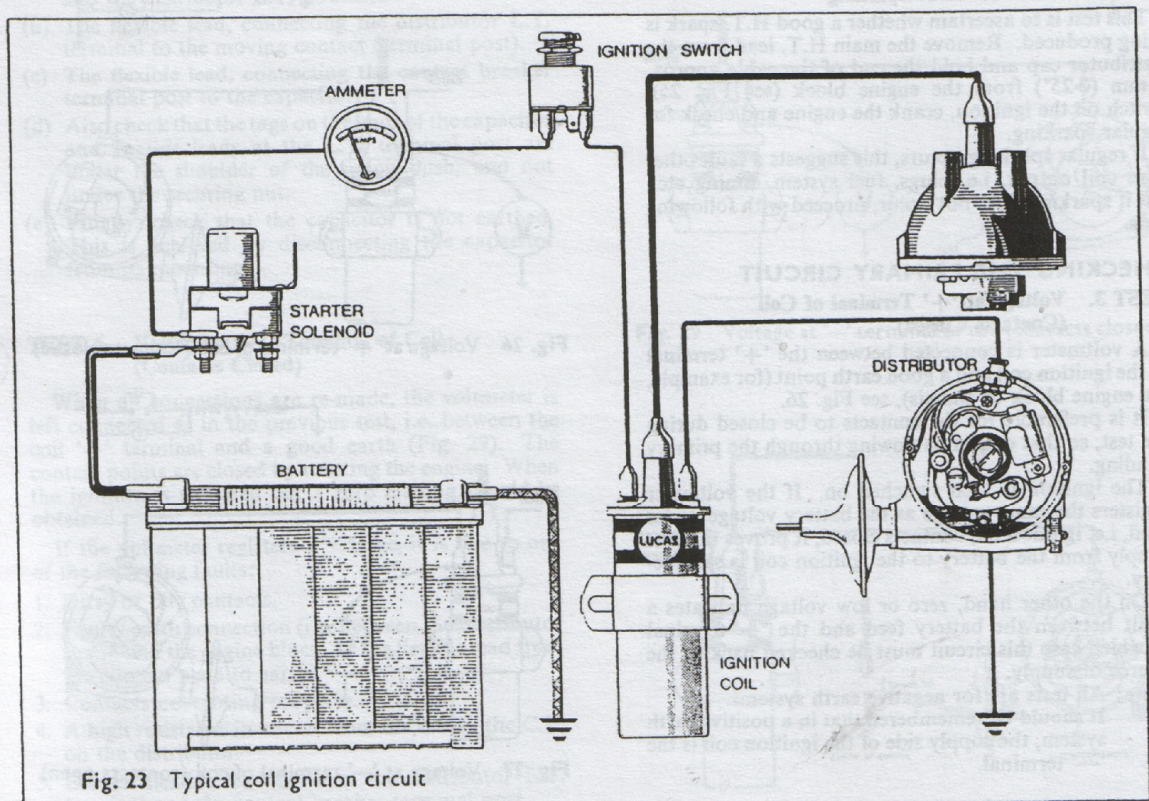
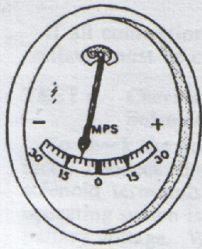
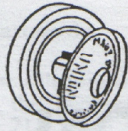

Fig. 23 Typical coil ignition circuit



Ammeter



Ignition Switch On



Lighting Switch On



Warning Light

Fig. 24 Battery — rapid check

### STANDARD COIL IGNITION SYSTEM

#### TEST 1. Battery: Rapid Check (Fig. 24)

When dealing with the ignition system a quick method of checking the battery is as follows: Switch on headlights and ignition and operate the starter. If the engine is turned over at a reasonable speed and the lights remain fairly bright, (they will dim slightly) we can assume that the battery will supply sufficient current for us to be able to carry out the ignition test procedure. Should the lights dim excessively and the starter appear sluggish, the complete test procedure must be applied to the battery (i.e. hydrometer and high rate discharge).

#### TEST 2. Check for H.T. Sparking

This test is to ascertain whether a good H.T. spark is being produced. Remove the main H.T. lead from the distributor cap and hold the end of the cable approx. 6 mm (0.25") from the engine block (see Fig. 25). Switch on the ignition, crank the engine and check for regular sparking.

If regular sparking occurs, this suggests a fault other than coil output, i.e. plugs, fuel system, timing etc., but if sparking does not occur, proceed with following tests.

### CHECKING THE PRIMARY CIRCUIT

#### TEST 3. Voltage at '+' Terminal of Coil (Contacts Closed)

A voltmeter is connected between the '+' terminal of the ignition coil and a good earth point (for example, the engine block or chassis), see Fig. 26.

It is preferable for the contacts to be closed during the test, so that current is flowing through the primary winding.

The ignition is then switched on. If the voltmeter registers the same voltage as the battery voltage under load, i.e. ignition on, contacts closed, it proves that the supply from the battery to the ignition coil is satisfactory.

On the other hand, zero or low voltage indicates a fault between the battery feed and the '+' terminal in which case this circuit must be checked back to the source of supply.

Note: All tests are for negative earth systems.

It should be remembered that in a positive earth system, the supply side of the ignition coil is the '-' terminal.

#### TEST 4. Voltage at '-' Terminal of Coil (Contacts Open)

Next, the primary winding is checked for continuity. The contact points must be open. A voltmeter is connected between the '-' terminal of the coil and earth (Fig. 27). When the ignition is switched on, the voltmeter should register battery voltage. If a zero reading is obtained, it indicates:

1. The primary winding of the ignition coil may be open-circuit, or
2. There may be a short-circuit to earth in the distributor or in the coil-distributor lead.

To help ascertain the actual cause of failure, the lead from the '-' 'L.T.' terminal of the coil is disconnected, and another voltmeter reading is taken.

- (a) If a zero reading is obtained, there is a break in the primary winding.
- (b) If the voltmeter registers battery voltage, the short-circuit is either on the coil to distributor lead or within the distributor.

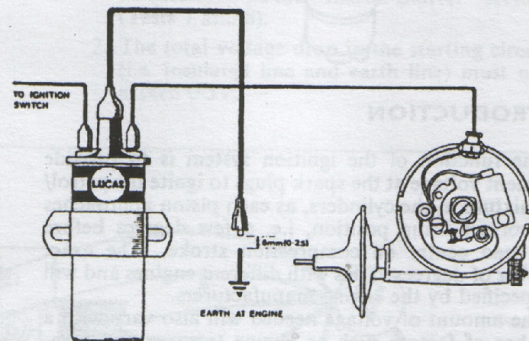

Fig. 25 Checking for H.T. sparking

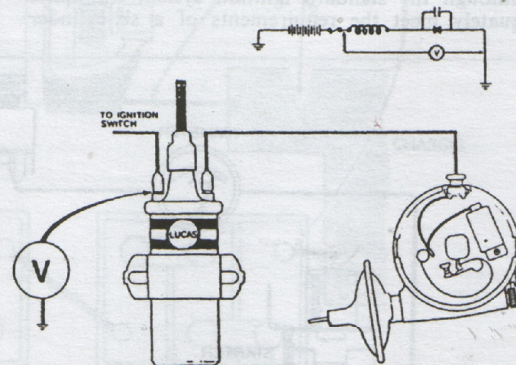

Fig. 26 Voltage at '+' terminal of coil (contacts closed)

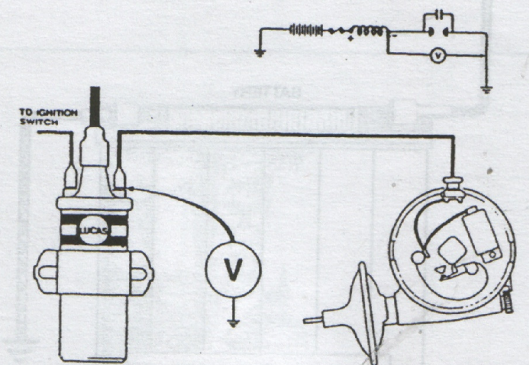

Fig. 27 Voltage at '-' terminal of coil (contacts open)

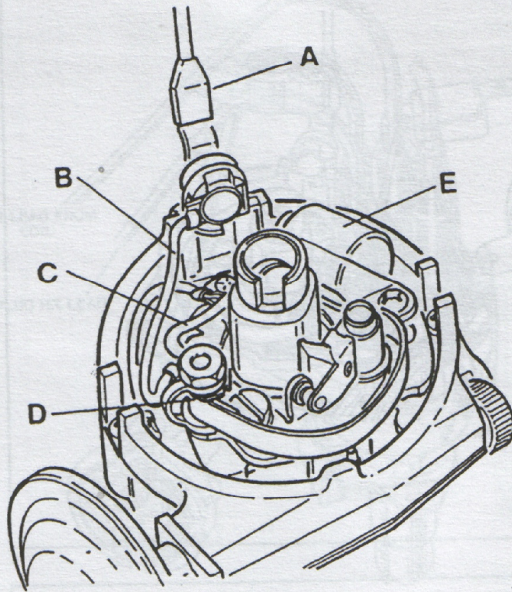

Fig. 28 Distributor: earth

#### TEST 5. Distributor - Earth

If the last test has shown that the distributor is short-circuited to earth, the following points in the 'L.T.' line should be checked, see Fig. 28.

- The lead between the ignition coil ('-' terminal) and the distributor L.T. terminal.
- The flexible lead, connecting the distributor L.T. terminal to the moving contact (terminal post).
- The flexible lead, connecting the contact breaker terminal post to the capacitor.
- Also check that the tags on the ends of the capacitor and flexible leads at the L.T. terminal post are under the shoulder of the nylon bush, and not under the securing nut.
- Finally, check that the capacitor is not earthed. This is achieved by disconnecting the capacitor from its mounting.

#### TEST 6. Voltage at '-' Terminal of Coil (Contacts Closed)

When all connections are re-made, the voltmeter is left connected as in the previous test, i.e. between the coil '-' terminal and a good earth (Fig. 29). The contact points are closed by rotating the engine. When the ignition is switched on, a zero reading should be obtained.

If the voltmeter registers a voltage, it is due to one of the following faults:

- Dirty or oily contacts.
- Faulty earth connection (i.e. between the distributor shank and the engine block, or the flexible lead from the contact plate to earth).
- Contacts not closing properly.
- A high resistance in circuit from the coil to the C.B. on the distributor.
- Broken flexible lead between the distributor L.T. terminal and the contact breaker terminal post.
- Open-circuit coil to distributor lead.

#### TEST 7. Checking the Secondary Circuit

The secondary circuit is checked to ensure that sufficient voltage is induced in the secondary winding to produce a high voltage spark.

One end of a known good H.T. lead is connected in the H.T. outlet of the ignition coil. The other end is held approximately 6 mm (0.25") from a clean area of the engine block (Fig. 30). With the distributor contacts closed, the ignition is switched on. The contacts are then flicked open and if a good strong spark is obtained across the gap for each flick, it proves that the ignition coil and capacitor are serviceable.

If no spark occurs until the 6 mm (0.25") gap is reduced, this indicates either a faulty capacitor or weak secondary output, proceed to next test.

#### TEST 8. Checking the Capacitor

The capacitor is checked by substitution.

The original capacitor is disconnected, and a test capacitor, known to be serviceable, is connected between the distributor L.T. terminal and earth, as shown in Fig. 31.

Switch on the ignition. If an unsatisfactory spark is obtained when the contacts are flicked open, as in the previous test, the secondary winding of the ignition coil is faulty. However, if the spark is now improved, it shows that the original capacitor was not functioning satisfactorily.

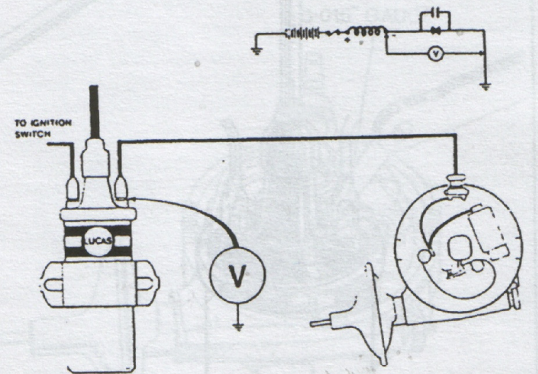

Fig. 29 Voltage at '-' terminal of coil (contacts closed)

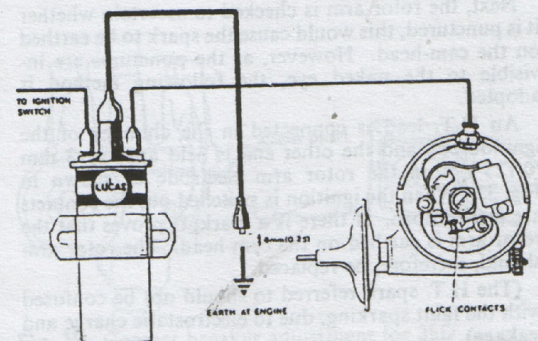

Fig. 30 Checking the secondary circuit

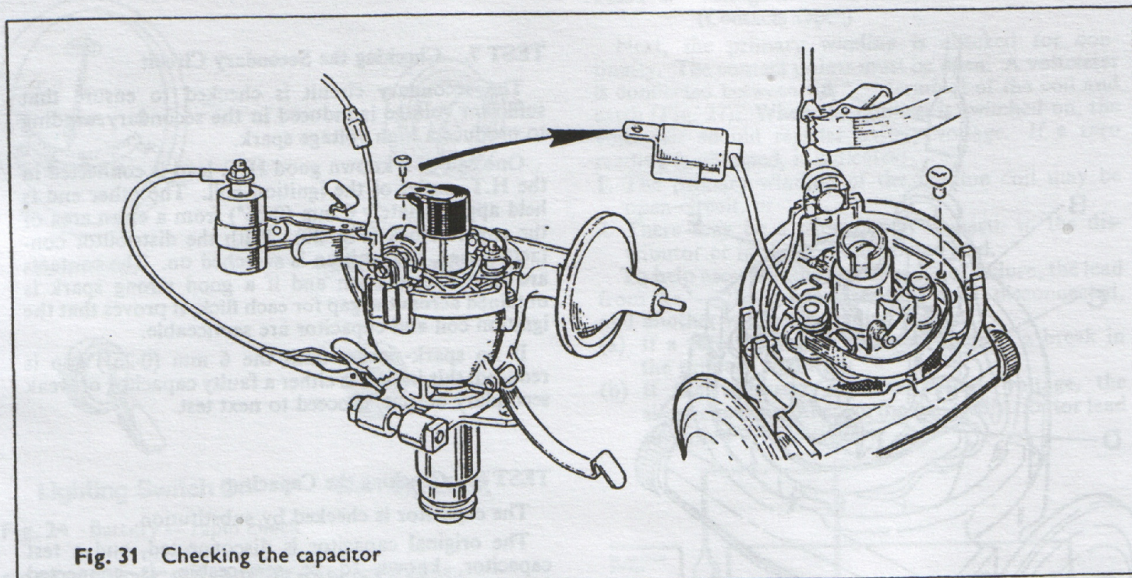

Fig. 31 Checking the capacitor

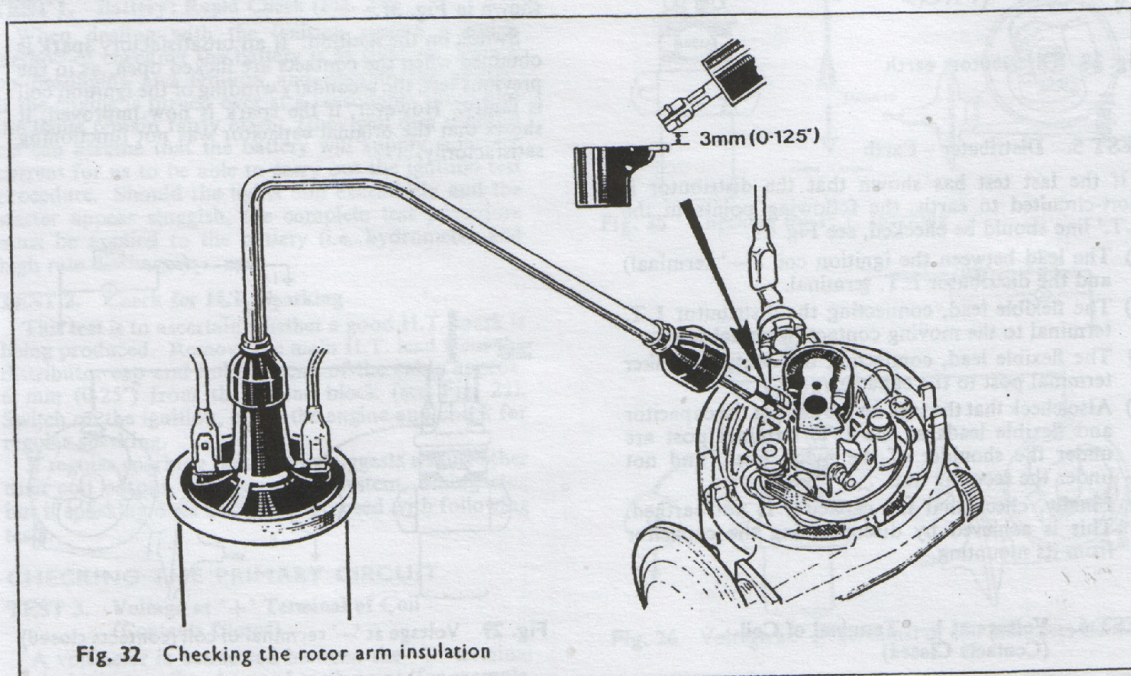

Fig. 32 Checking the rotor arm insulation

#### TEST 9. Checking the Rotor Arm Insulation

Next, the rotor arm is checked to ascertain whether it is punctured, this would cause the spark to be earthed on the cam-head. However, as the punctures are invisible to the naked eye, the following method is adopted.

An H.T. lead is connected in the chimney of the ignition coil and the other end is held approx. 3 mm (0.125") from the rotor arm electrode as shown in Fig. 32. When the ignition is switched on, the contacts are flicked open. If there is a spark, it proves that the rotor arm is earthed on the cam-head. The rotor arm should, therefore, be replaced.

(The H.T. spark referred to should not be confused with the faint sparking, due to electrostatic charge and leakage).

#### DISTRIBUTOR COVER AND H.T. LEADS (Fig. 33)

The distributor cover should be thoroughly cleaned, inside and outside, with a soft, dry cloth, paying particular attention to the space between the electrodes.

If the cover is "tracked" (shown by a thin, conducting track of burned bakelite between the electrodes or to earth), it should be replaced.

The condition of the H.T. cables, especially the insulation, is then checked.

When the insulation shows signs of cracking or perishing the cables must be renewed. Special care must be taken to maintain the correct firing order when replacing the H.T. cables.

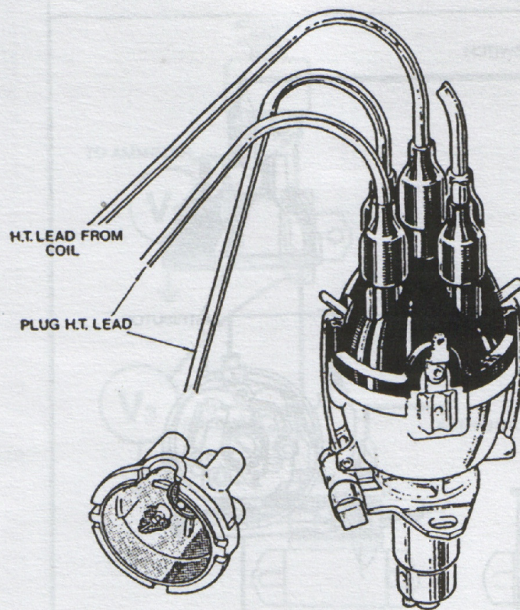

Fig. 33 Checking the distributor cover and leads

### CONTACT BREAKER ASSEMBLY AND GAP SETTING (Fig. 34)

The contact breaker must be maintained in good condition. Ensure that the contact surfaces are free from oil and grease. If the contacts show signs of excessive wear, they should be replaced.

When setting the contact breaker gap ensure that the contacts are fully open (i.e. the contact heel is on the peak of the cam lobe). A gauge of the appropriate thickness, 0.35–0.40 mm (0.014–0.016"), should make a sliding fit between the contacts. It is advisable to recheck the gap after adjustment, to ensure no movement has taken place while the screw was being tightened.

Providing the distributor is in good mechanical condition, an alternative method of setting the contact gap is to use an accurate dwell angle meter.

### CONTACT BREAKER ADJUSTMENT FOR 35D DISTRIBUTORS

The contact breaker setting is adjusted by rotating the hexagon-shaped stud which protrudes through the distributor body. It is adjusted to give the correct dwell angle (contact closed period), see Fig. 35.

Adjustment should be carried out using a dwell meter with the engine running. The dwell angle should be set within the limits specified by the manufacturer. The hexagon-shaped stud is screwed anti-clockwise to increase the dwell angle (close the contact point gap) and clockwise to decrease the dwell angle (open the contact gap).

Note: Static and stroboscopic timing are described at the end of the chapter.

### BALLASTED IGNITION SYSTEM

Ballasted ignition systems (Fig. 36) are used to improve engine starting especially in very cold conditions, and also to provide maximum spark efficiency at high engine speeds.

Battery voltage is at its lowest when the engine is being cranked. This drain on the battery causes the terminal voltage to fall well below its normal value. Consequently, during starting the H.T. spark is obtained from an ignition coil which is operating from a reduced voltage. In these conditions the ignition performance is usually satisfactory, but in extremely cold conditions it is preferable to use a system in which the voltage applied to an appropriate coil remains constant.

A ballast resistor is connected in series with the ignition coil primary winding, and the circuit is arranged to short out the resistor when the starting motor is operating.

The ballast resistor normally comprises a coil of resistive wire housed in a porcelain block with electrical connections by means of 'Lucar' connectors.

The ballast resistor is clamped to its fixing (often an ignition coil mounting bolt) by a bracket surrounding the porcelain block.

Note: The resistor may take the form of a resistive cable on some applications.

The cold starting performance is improved by permitting the ignition coil to operate at a voltage slightly above its normal operating voltage. Slight overloading is not detrimental to the coil as it occurs only while the engine is being cranked.

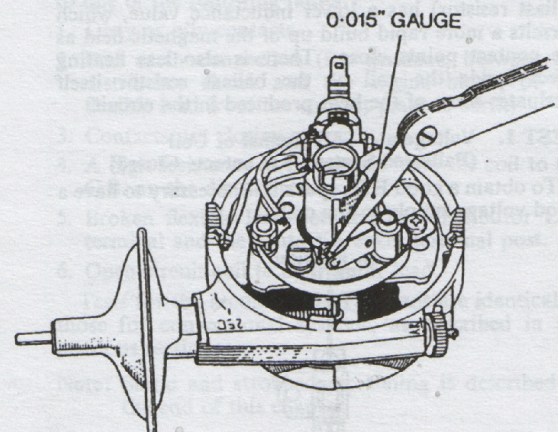

Fig. 34 Checking the contact breaker assembly and gap setting

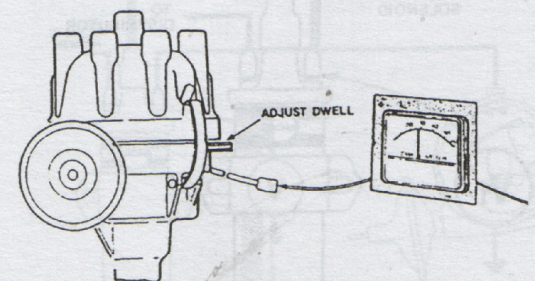

Fig. 35 Contact breaker adjustment for 35D distributors

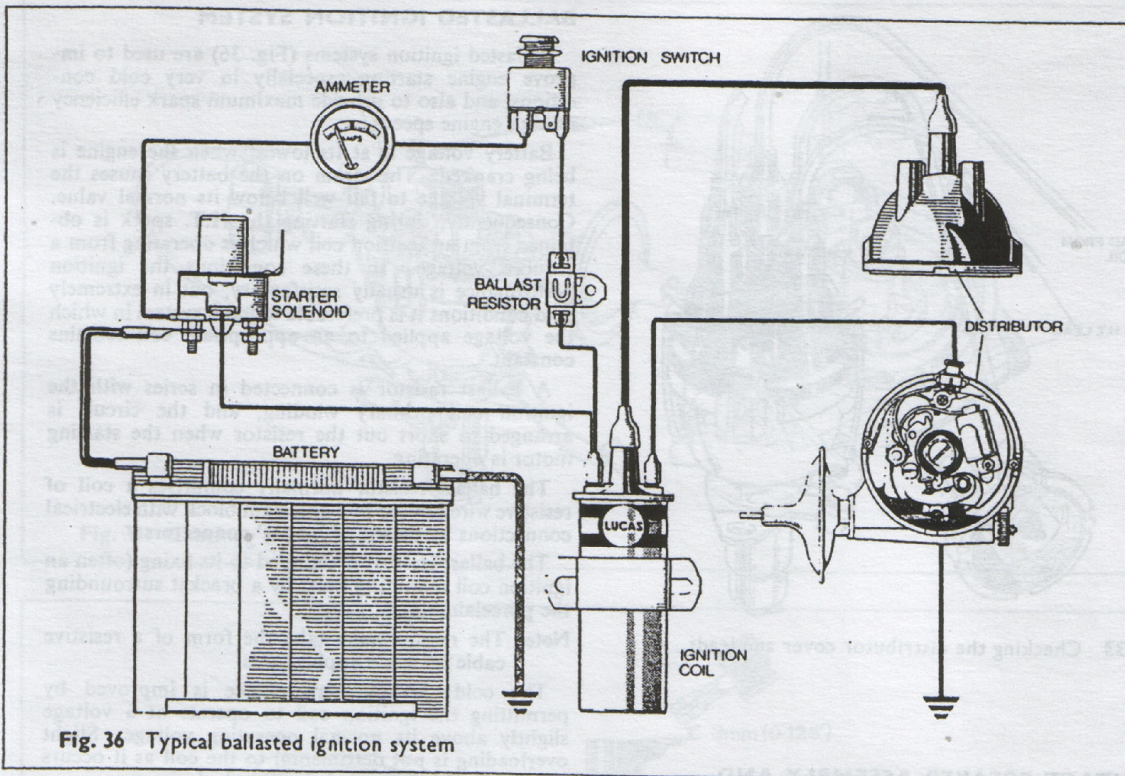

Fig. 36 Typical ballasted ignition system

The primary winding of an ignition coil (used with a ballast resistor) has a lower inductance value, which permits a more rapid build up of the magnetic field as the contact points close. There is also less heating effect inside the coil as the ballast resistor itself dissipates some of the heat produced in the circuit.

**TEST 1. Voltage at '+' Terminal of Coil (Ballasted System) - (Contacts Closed)**

To obtain a good H.T. spark it is necessary to have a good voltage supply to the coil.

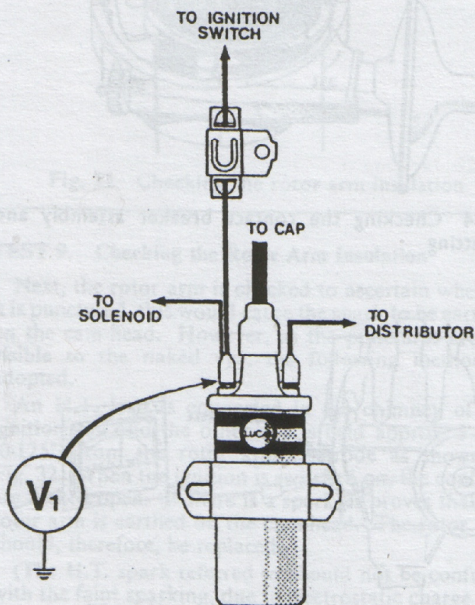

Fig. 37 Voltage at '+' terminal of coil (contacts closed)

Connect the voltmeter (V1) between the '+' terminal of the coil and a good earth, as shown in Fig. 37. The contacts should be closed during the test to enable current to flow through the primary winding.

Switch on the ignition and the voltmeter should register approx. 6V for a 12 volt ballasted system. If the correct voltage is indicated, the supply from the battery to the ignition coil is satisfactory. Next, temporarily earth the coil negative terminal and crank the engine by the starter; any increase in the voltage indicates a satisfactory circuit. A slight decrease indicates a faulty solenoid switch or lead from the solenoid switch. Remove temporary earth connection.

If no readings are obtained, proceed with the Tests 2 and 3. If correct readings or battery volts are obtained, proceed to Test 4.

**TEST 2. Voltage at '+' Side of Ballast Resistor**

With the contacts closed, connect the voltmeter (V2) between the feed side of the ballast resistor and a good earth (Fig. 38). On applications with resistive supply cable, connect the voltmeter between the ignition switch end of the cable and a good earth. If battery voltage is registered, proceed to Test 3. But if no voltage is indicated, check back along supply cable.

**TEST 3. Voltage at Coil Side of Ballast Resistor**

Connect the voltmeter (V3) between the coil side of the ballast resistor and a good earth (Fig. 38). The ignition is switched on. No reading indicates a faulty ballast resistor.

**TEST 4. Voltage at '-' Terminal of Coil (Contacts Open)**

With contacts open, connect the voltmeter between the coil '-ve' terminal and earth as (V4) in Fig. 39. With ignition on, voltmeter should read battery voltage. No reading indicates open-circuit coil primary winding or short-circuit on the lead from the coil to distributor or within the distributor.

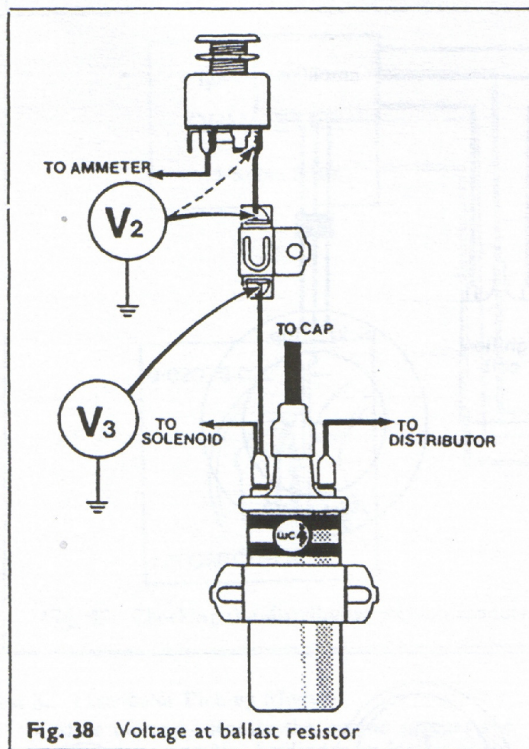

Fig. 38 Voltage at ballast resistor

Repeat test with coil '-ve' lead disconnected; if reading now appears, fault is on distributor or lead. No reading - faulty coil.

**TEST 5. Distributor - Earth**

If the last test has shown that the distributor is short-circuited to earth, the following points in the L.T. line should be checked, see Fig. 40.

- (A) The lead between the ignition coil ('-ve' terminal) and the distributor L.T. terminal.
- (B) The flexible lead, connecting the distributor L.T. terminal to the moving contact (terminal post).
- (C) The flexible lead, connecting the contact breaker terminal post to the capacitor.
- (D) Also, check that the tags on the end of the capacitor and flexible leads at the L.T. terminal post are under the shoulder of the nylon bush, and not under the securing nut.
- (E) Finally, check that the capacitor is not earthed. This is achieved by disconnecting the capacitor from its mounting.

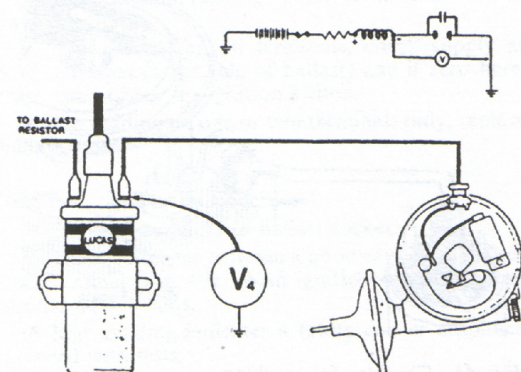

Fig. 39 Voltage at '-' terminal of coil (contacts open)

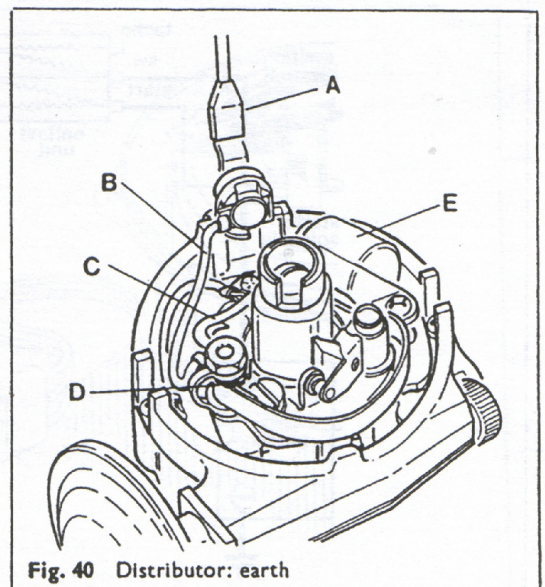

Fig. 40 Distributor: earth

**TEST 6. Voltage at '-' Terminal of Coil (Contacts Closed)**

When all connections are re-made, the voltmeter is left connected as in Test 4, (i.e. between the coil '-ve' terminal and a good earth) (Fig. 41). The contact points are closed by rotating the engine. When the ignition is switched on, a zero reading should be obtained. If the voltmeter registers a voltage, it is due to one of the following faults:

1. Dirty or oily contacts.
2. Bad earth connection (for instance, between the distributor shank and the engine block, or the flexible lead from the contact plate to earth).
3. Contacts not closing properly.
4. A high resistance in the circuit from the coil to the C.B. on the distributor.
5. Broken flexible lead between the distributor L.T. terminal and the contact breaker terminal post.
6. Open-circuit coil to distributor lead.

Tests for the secondary H.T. circuit are identical to those for conventional systems, as described in the previous section.

Note: Static and stroboscopic timing is described at the end of this chapter.

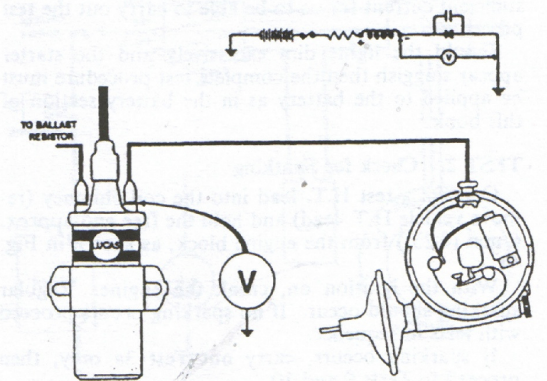

Fig. 41 Voltage at '-' terminal of coil (contacts closed)

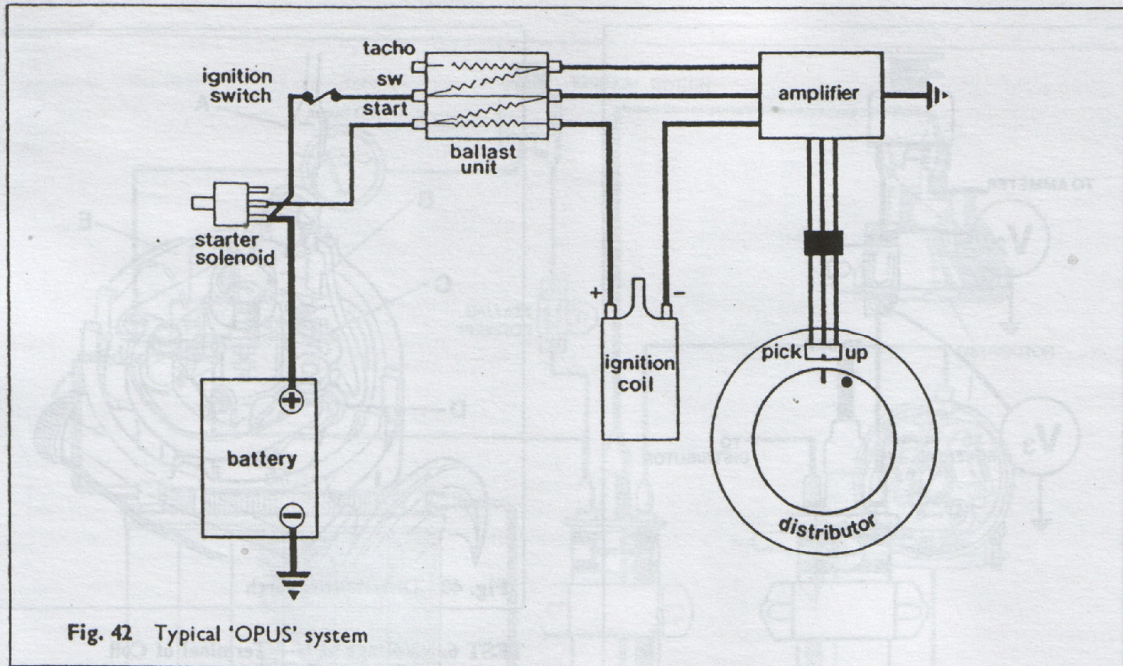

Fig. 42 Typical 'OPUS' system

### INTRODUCTION

The "OPUS" (Oscillating pick-up system) Fig. 42, is a fully-electronic system where the distributor cam and contact breaker assembly have been replaced by a pick-up module and rotating drum carrying a number of ferrite rods, one for each engine cylinder. As each rod passes in front of the module a small voltage signal is generated by the module winding, this signal is then transmitted to the amplifier. The transistorised circuits in the amplifier will instantly switch off the current in the ignition coil primary winding, thereby producing an induced coil secondary voltage (i.e. the 'spark').

The ignition coil used is a special low-inductance type designed for high speed operation and as such is particularly suitable for 8- and 12-cylinder engines.

As no contacts are used, the problem of contact breaker bounce at high speed is non-existent.

### OPUS IGNITION TEST PROCEDURE

#### TEST 1. Battery - Rapid Check (Fig. 43)

Switch on the headlights and ignition and operate the starter. If the engine is turned over at a reasonable speed and the lights remain fairly bright (they will dim slightly), we can assume that the battery will supply sufficient current for us to be able to carry out the test procedure.

Should the lights dim excessively and the starter appear sluggish then the complete test procedure must be applied to the battery as in the battery section of this book.

#### TEST 2. Check for Sparking

Connect a test H.T. lead into the coil chimney (remove vehicle H.T. lead) and hold the free end approx. 6 mm (0.25") from the engine block, as shown in Fig. 44.

With the ignition on, crank the engine. Regular sparking should occur. If no sparking occurs proceed with tests in sequence.

If sparking occurs, carry out Test 3a only, then proceed to Tests 9 and 10.

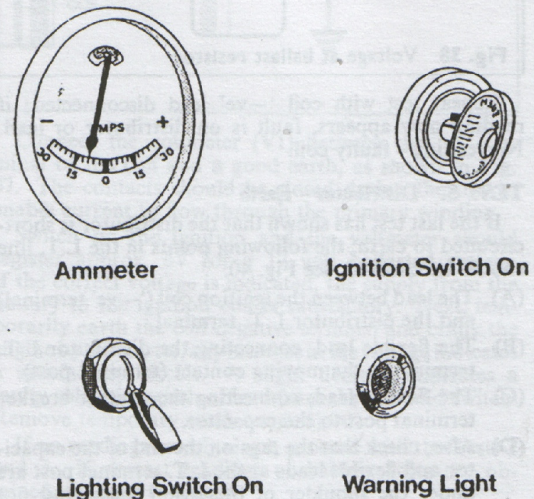

Fig. 43 Battery - rapid check

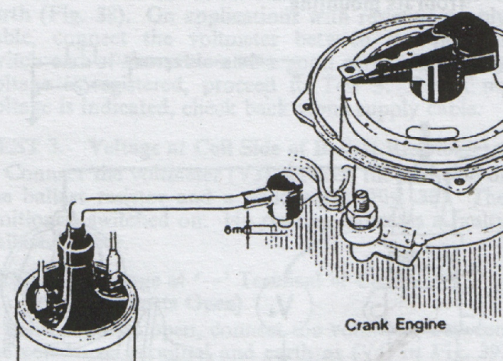

Fig. 44 Checking for sparking

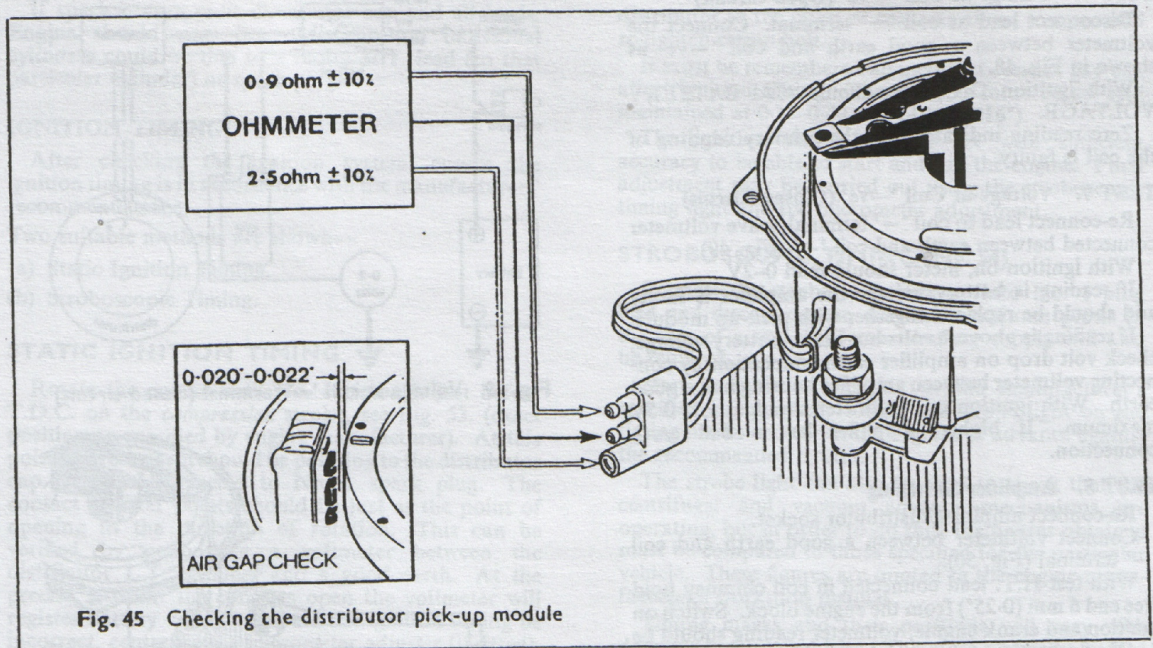

Fig. 45 Checking the distributor pick-up module

**Test 3. Distributor Pick-up Module**

- (a) Module air gap - Rotate the engine so that the ferrite rod marked No. 1 cylinder on Jaguar or the rod immediately under the rotor electrode on Aston Martin, is in line with the pick-up module, see Fig. 45.  
The gap between module and timing rotor should be a parallel 0.50-0.55 mm (0.020"-0.022"). If incorrect, adjust by slackening module fixing screws.
- (b) Disconnect the distributor to amplifier plug and on the distributor side, use an ohmmeter to check the resistance values between the centre and each outer terminal. The readings should be: Centre terminal to outer terminal with red cable 2.5 ohms  $\pm 10\%$ , centre terminal to outer terminal with black cable 0.9 ohm  $\pm 10\%$ . Leave plug disconnected.

**TEST 4. Check Ballast Resistor (9BR)**

Withdraw socket at amplifier side of ballast resistor. Connect the voltmeter between a good earth and each terminal of the ballast resistor as shown in Fig. 46. *Caution:* Ensure that the voltmeter prod does not touch the resistor housing while in contact with the terminals.

With ignition on, reading at each terminal should be battery voltage.

If zero reading on all terminals, check supply at S.W. terminal (other side of ballast) and if zero here, trace circuit back via ignition switch.

If zero reading on one or two terminals only, replace ballast unit.

**TEST 5. Voltage at Coil '+ve'**

Re-connect amplifier to ballast socket.

Connect voltmeter between a good earth and the coil '+' terminal (Fig. 47). With ignition on, the reading should be 4-6 volts.

A high reading indicates a faulty coil or amplifier; proceed with tests.

Zero reading indicates a fault in the amplifier to coil '+' lead.

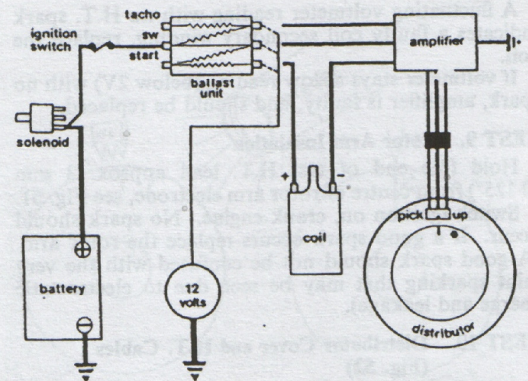

Fig. 46 Checking ballast resistor (9BR)

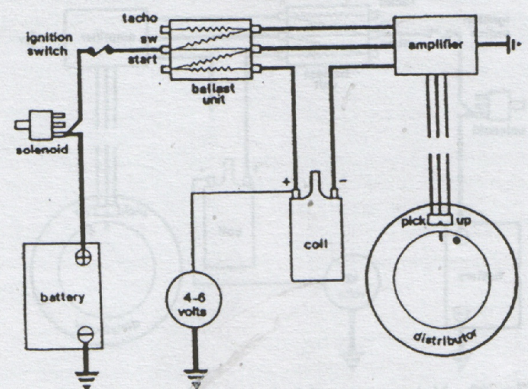

Fig. 47 Voltage at '+' terminal of coil

### TEST 6. Voltage at Coil '-ve' (Open-Circuit)

Disconnect lead at coil '-' terminal. Connect the voltmeter between a good earth and coil '-ve' as shown in Fig. 48.

With ignition ON, meter should read BATTERY VOLTAGE.

Zero reading indicates that the primary winding of the coil is faulty.

### TEST 7. Voltage at Coil '-ve' (Closed Circuit)

Re-connect lead to coil '-' terminal, leave voltmeter connected between earth and coil '-' (Fig. 49).

With ignition on, meter should read 0-2V.

If reading is battery voltage the amplifier is faulty and should be replaced together with pick-up module.

If reading is above 2 volts but below battery voltage, check volt drop on amplifier earth connection by connecting voltmeter between amplifier housing and a good earth. With ignition on, voltmeter should show 0.5V maximum. If higher, amplifier has a bad earth connection.

### TEST 8. Amplifier Switching

Re-connect amplifier/distributor socket.

Connect voltmeter between a good earth and coil '-' terminal (Fig. 50).

With test H.T. lead connected in coil chimney hold free end 6 mm (0.25") from the engine block. Switch on ignition and crank engine, voltmeter reading should be 3-4V, fluctuating with regular sparking from H.T. lead.

A fluctuating voltmeter reading with no H.T. spark indicates a faulty coil secondary winding, replace the coil.

If voltmeter stays at low reading (below 2V) with no spark, amplifier is faulty, and should be replaced.

### TEST 9. Rotor Arm Insulation

Hold free end of test H.T. lead approx. 3 mm (0.125") from centre of rotor arm electrode, see Fig. 51.

Switch ignition on, crank engine. No spark should occur. If a good spark occurs replace the rotor arm. (A good spark should not be confused with the very faint sparking that may be seen due to electrostatic charge and leakage).

### TEST 10. Distributor Cover and H.T. Cables (Fig. 52)

The distributor cover should be clean and dry. The H.T. carbon brush must be free to move in its holder. If the distributor cover electrodes are badly eroded or tracking has occurred, a new cover should be fitted.

Carry out test for sparking using vehicle main H.T. lead instead of test lead, if no spark, lead is faulty.

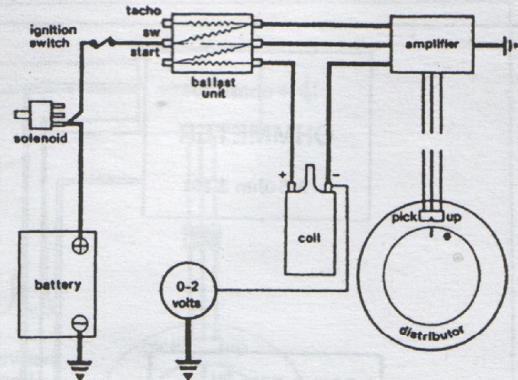

Fig. 49 Voltage at coil '-' terminal (closed circuit)

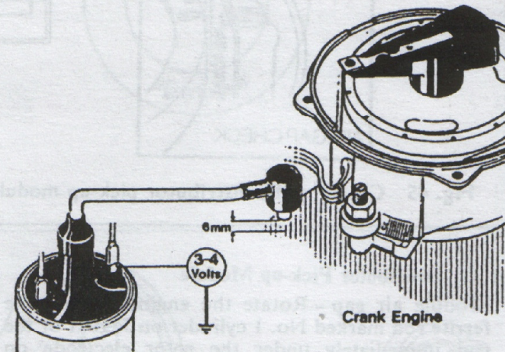

Fig. 50 Checking the amplifier switching

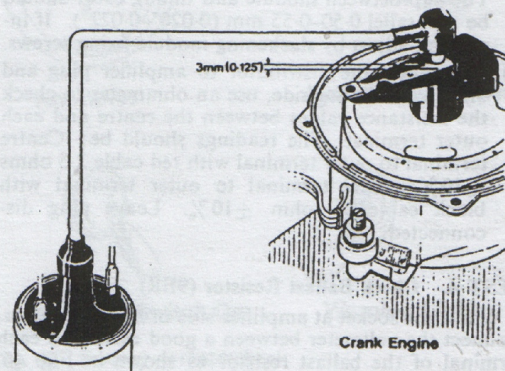

Fig. 51 Checking the rotor arm insulation

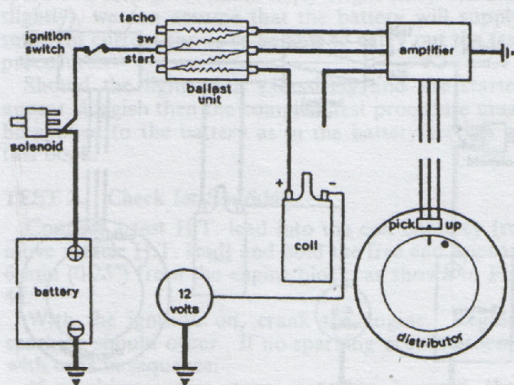

Fig. 48 Voltage at coil '-' terminal (open circuit)

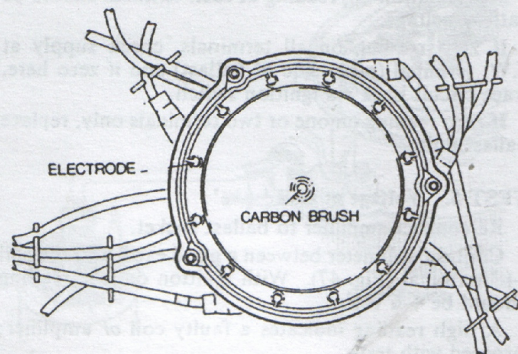

Fig. 52 Checking the distributor cover and H.T. cables

If spark occurs re-fit distributor cap and all leads. Engine should now fire. Misfiring on individual cylinders could be due to a faulty H.T. lead (to that particular cylinder) or spark plugs.

### IGNITION TIMING

After checking the ignition system, ensure the ignition timing is in accordance with the manufacturers' recommendations.

Two suitable methods are shown—

- (a) Static Ignition Timing.
- (b) Stroboscopic Timing.

### STATIC IGNITION TIMING

Rotate the engine until No. 1 piston is just before T.D.C. on the *compression* stroke, see Fig. 53. (exact position as specified by engine manufacturer). At this point the rotor arm should be pointing to the distributor cap segment connected to No. 1 spark plug. The contact breaker points should be just at the point of opening in the direction of rotation. This can be verified by connecting a voltmeter between the distributor L.T. terminal and a good earth. At the precise moment the contacts open the voltmeter will register battery voltage. Should the ignition timing be incorrect, centralise the micrometer adjuster (if fitted), slacken the distributor clamp bolt and position the

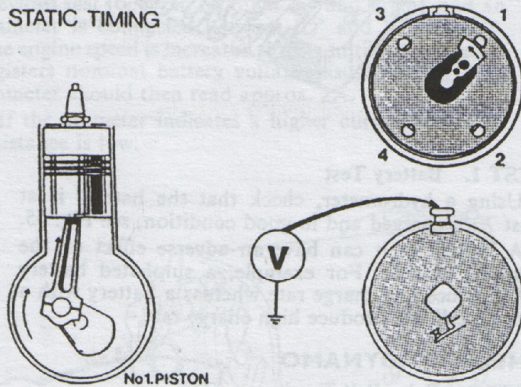

Fig. 53 Static ignition timing

distributor to the point of contacts about to open and re-tighten clamp bolt.

It must be remembered an incorrect contact gap can affect ignition timing. The contacts must be set and maintained at 0.35–0.40 mm (0.014"–0.016").

The ignition timing is now set with sufficient accuracy to be able to start and run the engine. Final adjustment may be carried out using the stroboscopic timing light and the micrometer adjustment.

### STROBOSCOPIC TIMING (Fig. 54)

Connect the strobe H.T. pick-up into No. 1 plug lead and disconnect the distributor vacuum pipe. In the case of a separate strobe, battery supply will also be required.

Start and run the engine at the manufacturer's specified idling speed. Direct the strobe light on the timing marks and check the degrees of advance against the recommended figures.

The strobe light can also be used to check that the centrifugal and vacuum advance mechanisms are operating, but in order to do this, the figures obtained must be compared to those specified for the particular vehicle. These figures are quoted in the engine manufacturer's workshop manual.

Timing marks and their positions will vary with different types of vehicles. These are normally quoted in the vehicle manufacturer's information.

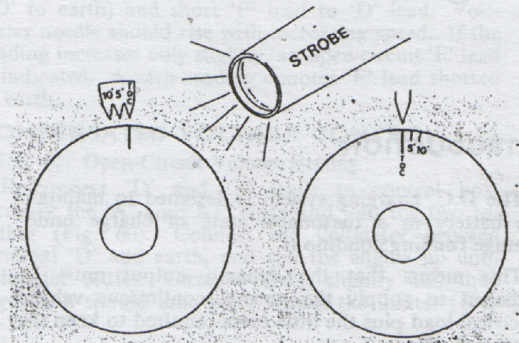
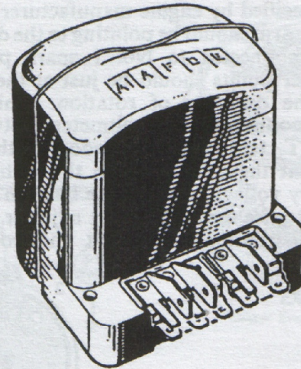
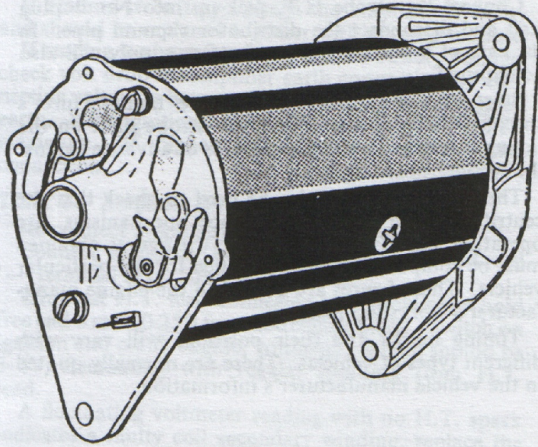
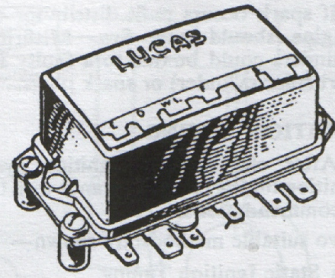

Fig. 54 Stroboscopic timing

# DYNAMOS AND CONTROL BOXES



## INTRODUCTION

The D.C. charging system is designed to maintain the battery in a reasonable state of charge under average running conditions.

This means that the dynamo output must be sufficient to supply the normal continuous vehicle electrical load plus the little extra required to keep the battery charged.

The inherent design of the dynamo is such that it must always be under some form of control, both to protect the machine against overload and to protect the battery against overcharge.

A control box, therefore, is designed to operate with a specific type of dynamo on a given application.

For many years the "Compensated Voltage Control" (2-bobbin) system has been employed, and in fact is still used on certain present-day production vehicles. However, with the increase in electrical equipment fitted to the modern vehicle, it became necessary to utilise a system better suited to present-day requirements. This brought about the "Current Voltage Control" (3-bobbin) system. The main advantage of this system is that it allows maximum safe dynamo output for a longer period of time when the battery is in a discharged condition.

Dynamos or control boxes may be replaced as individual units provided two rules are strictly observed.

1. That the *correct* replacement unit is fitted.
2. That, after fitting, the test procedure is carried out on *both* units to ensure that the complete system is operating efficiently.

## TEST 1. Battery Test

Using a hydrometer, check that the battery is at least 70% charged and in good condition, see Fig. 55.

A battery fault can have an adverse effect on the charging system. For example, a sulphated battery will produce low charge rate whereas a battery with a shorted cell will produce high charge rate.

## CHECKING DYNAMO

### TEST 2. Drive Belt Tension

Allow 13-19 mm (0.5"-0.75") play when moderate finger pressure is applied to the longest run of the belt, Fig. 56.

The dynamo will not charge the battery if the drive belt is too slack. On the other hand, an excessively tight belt will damage the bearings.

If the belt is worn or oily it should be replaced.

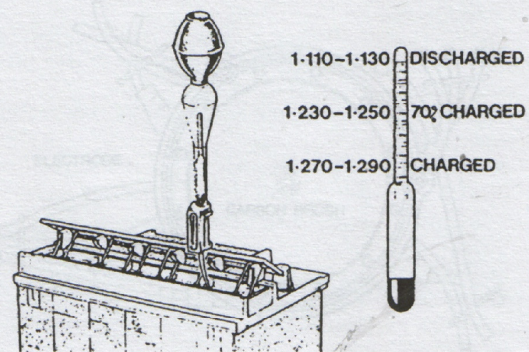

Fig. 55 Hydrometer test

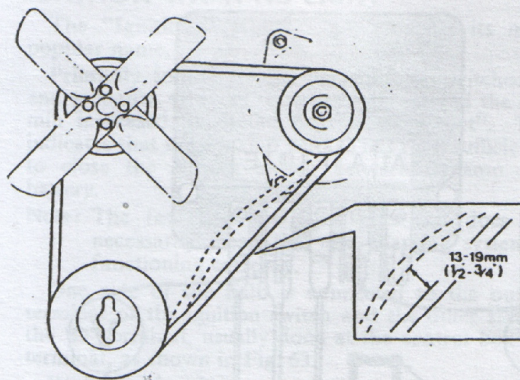

Fig. 56 Drive belt tension

**TEST 3. Testing the Armature Circuit**

Disconnect the leads at the dynamo and connect the voltmeter between a good earth and the dynamo 'D' terminal, Fig. 57. Start the engine and slowly increase the speed to approx. 1,500 rev/min. The voltmeter should register 1.5-3.0V.

**TEST 4. Testing the Field Circuit**

The voltmeter is kept in the same position as for the previous test (between terminal 'D' and earth), and an ammeter is connected between 'D' and 'F', Fig. 58. The engine speed is increased slowly, until the voltmeter registers nominal battery voltage (usually 12V). The ammeter should then read approx. 2A.

If the ammeter indicates a higher current, the field resistance is low.

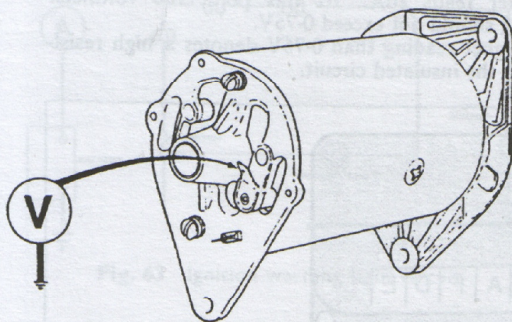

Fig. 57 Testing the armature circuit

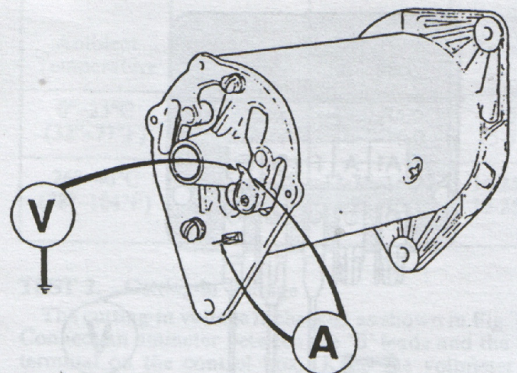

Fig. 58 Testing the field circuit

**TEST 5. Checking Dynamo Leads**

If the correct readings are obtained on the tests at the dynamo, the fault could be in the wiring between dynamo and control box. To prove these cables, test as follows: Re-connect the leads at the dynamo and disconnect 'D' and 'F' at the control box. Connect one lead of the voltmeter to earth, the other to the 'D' lead, Fig. 59, and run the engine at charging speed. The reading should be the same as at 'D' on the dynamo (1.5-3.0V). No reading indicates a faulty 'D' lead, a high reading indicates a short between the 'D' and 'F' cables.

If the reading is correct, leave voltmeter in position ('D' to earth) and short 'F' lead to 'D' lead. Voltmeter needle should rise with increasing speed. If the reading increases only slightly, an open-circuit 'F' lead is indicated. A zero reading denotes 'F' lead shorted to earth.

**COMPENSATED VOLTAGE CONTROL**

**TEST 6. Open-Circuit Voltage Setting**

Re-connect 'D' and 'F' leads to control box. Remove the 'A' and 'A1' leads and join the two together (Fig. 60). Connect the voltmeter between terminal 'D' and earth, and run the engine up until voltmeter settles. Increase speed slightly and then regulation should take place within the limits: 16 to 16.5V.

If the voltmeter readings are outside the appropriate limits, the voltage setting must be adjusted by turning the adjustment screw at the back of the regulator frame. Turn the screw clockwise (or inwards) to increase the voltage, and anti-clockwise (or outwards) to reduce it.

If turning the adjustment screw has no effect on the voltage setting (reading off the scale), check for a faulty control box earth connection, or an open-circuit shunt winding.

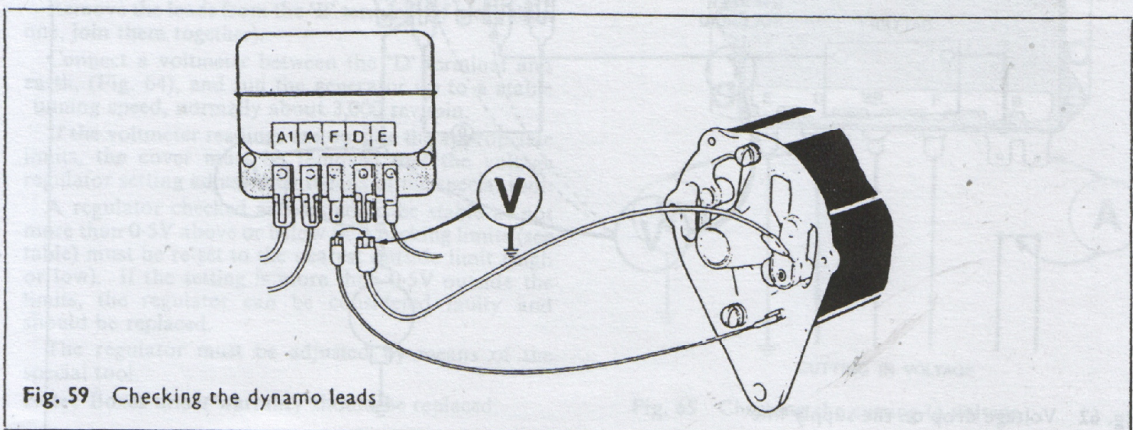
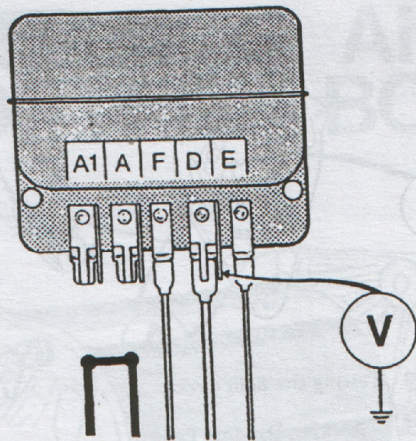

Fig. 59 Checking the dynamo leads



OPEN CIRCUIT VOLTAGE SETTING

Fig. 60 Checking the open circuit voltage setting

**TEST 7. Cutting-in Voltage**

Next, the cutting-in voltage must be checked (Fig. 61). Connect an ammeter between the control box 'A' terminal and the leads which have been disconnected from the 'A' and 'A1' terminals. The voltmeter is kept in the same position, between the 'D' terminal and earth. Switch on headlights. Start the engine and gradually increase the speed.

When the cut-out points close the voltmeter needle will kick back. This should occur within the limits 12.7-13.3V. If it does not, the cut-out setting should be adjusted by means of the adjusting screw at the back of the cut-out. Adjust with engine stationary and repeat test.

Increase the engine speed. The ammeter reading should increase with speed. (The actual reading will depend on the state of the battery charge and the electrical load).

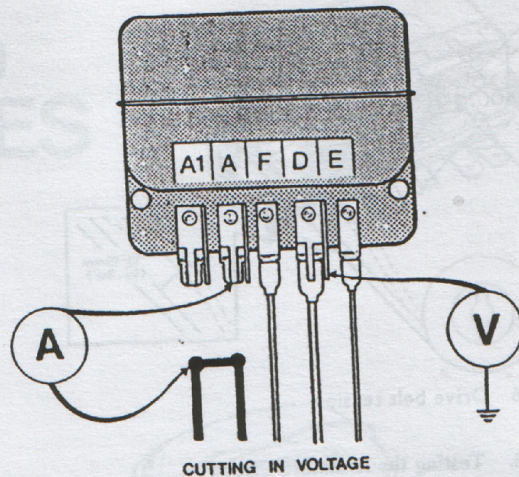

CUTTING IN VOLTAGE

Fig. 61 Checking the cutting-in voltage

Gradually reduce the engine speed. The ammeter needle should fall until it indicates a discharge (or reverse) current of 3-5 amps. The ammeter needle should return to zero when the cut-out points open. Replace all control box leads, ensuring correct connections.

**TEST 8. Checking Voltage Drop on Supply Line**

Remove the 'D' lead from the dynamo terminal and connect the ammeter into the circuit, see Fig. 62.

Connect the voltmeter between the dynamo 'D' lead (removed) and the battery supply terminal at the starter solenoid.

Start and run the engine at charging speed until the ammeter reads 10A. At this point the voltmeter reading should not exceed 0.75V.

A higher reading than 0.75V denotes a high resistance in the insulated circuit.

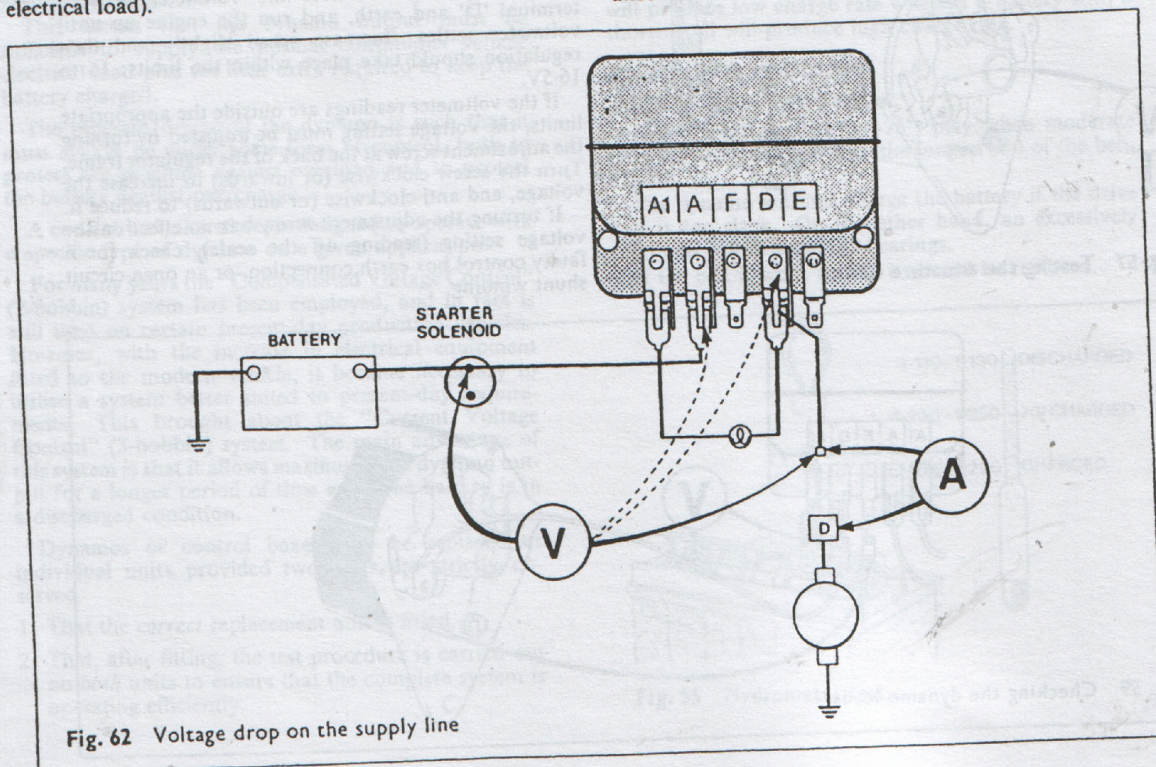

Fig. 62 Voltage drop on the supply line

## IGNITION WARNING LIGHT

The "Ignition Warning Light", to use its more popular name, has two basic functions.

Primarily, to indicate that the ignition is switched on and secondly, when the engine is started and the rev/min increased, it should fade and "go out". This indicates that the dynamo voltage has risen sufficiently to close the cut-out switch between dynamo and battery.

**Note:** The fact that the light goes out does *not* necessarily mean that the charging system is functioning correctly.

One side of the bulb is connected to the output terminal of the ignition switch and the other side to the 'D' terminal, usually done at the control box 'D' terminal, as shown in Fig. 63.

With the ignition on and the engine stationary, battery voltage is applied to one side of the warning light via the ignition switch. The other side is connected to earth via the dynamo armature and brush-gear.

When the engine is started and the rev/min increased, voltage from the dynamo 'D' terminal rises at one side of the bulb to oppose battery voltage at the other side. The warning light then fades until both voltages are equal, when it is completely extinguished. At almost the same instant the cut-out points close (13V) thus shorting out the warning light and allowing the bulb to remain out.

A warning light that "glows" faintly under normal running conditions can be due to any of the following faults.

1. Internal high resistance in the ignition switch.
2. Dirty control box cut-out contacts.
3. A slipping fan belt (if slipping badly enough).

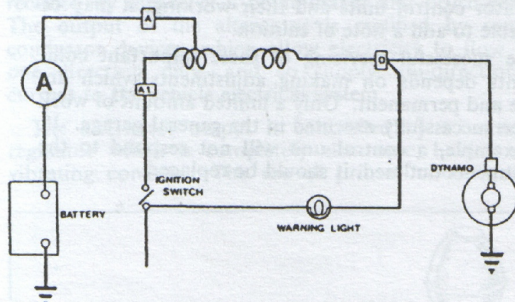

Fig. 63 Ignition warning light circuit

## CURRENT VOLTAGE CONTROL

### TEST 1. Voltage Regulator Setting

Remove the leads from the 'B' terminal (if more than one, join them together).

Connect a voltmeter between the 'D' terminal and earth, (Fig. 64), and run the generator up to a stable running speed, normally about 3,000 rev/min.

If the voltmeter readings are outside the appropriate limits, the cover must be removed and the voltage regulator setting adjusted by means of the special tool.

A regulator checked and found to be stable at not more than 0.5V above or below the checking limits (see table) must be re-set to the nearest outside limit (high or low). If the setting is more than 0.5V outside the limits, the regulator can be considered faulty and should be replaced.

The regulator must be adjusted by means of the special tool.

**Note:** Boxes under warranty should be replaced.

Ambient Temperature	O.C. Voltage Checking	If Between	Reset to
0°-25°C (32°-77°F)	14.5-15.5	14.0-14.5 15.5-16.0	14.5 15.5
26°-40°C (78°-104°F)	14.25-15.25	13.75-14.25 15.25-15.75	14.25 15.25

### TEST 2. Cutting-in Voltage

The cutting-in voltage is checked as shown in Fig. 65. Connect an ammeter between the 'B' leads and the 'B' terminal on the control box. Keep the voltmeter in the same position as the previous test (between terminal 'D' and earth). Switch on headlights. Start the engine and gradually increase the speed.

When the cut-out points close, the voltmeter needle will kick back. This should occur within the limits 12.7-13.3V. If it does not, the cut-out setting should be adjusted by means of the adjustment screw at the back of the cut-out frame (6GC) or special tool (RB340).

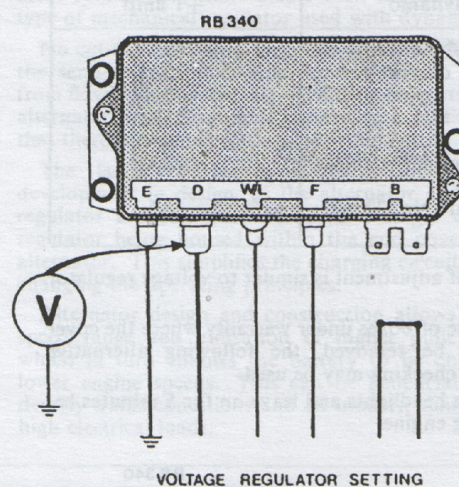

Fig. 64 Checking the voltage regulator setting

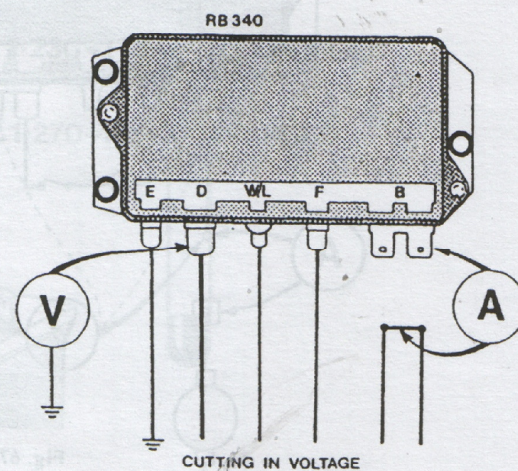

Fig. 65 Checking the cutting-in voltage

Increase the engine speed and the reading on the ammeter should increase with speed, (dependent on state of battery charge and electrical load).

Gradually reduce the engine speed. The ammeter needle should fall until it indicates a discharge (or reverse) current of 3-10 amps. The ammeter needle should return to zero when the cut-out points open.

**TEST 3. Current Regulator Setting (Fig. 66)**

For the purpose of this test the dynamo must produce its safe maximum output regardless of the state of charge of the battery, therefore the voltage regulator must be made inoperative.

This is achieved by connecting a crocodile clip across the voltage regulator contacts.

Switch off all lights (from previous test).

With the ammeter still in position (connected in series with 'B' lead) start the engine and increase the rev/min to just above charging speed. The meter reading should correspond to the figure shown in the table for a given dynamo.

Associated dynamo	Nominal Setting $\pm 1$ amp
C40/1 (4½" dia. fan)	19A
C40/1 (5" dia. fan)	22A
C40A	10.5A
C40L	25A
C42	30A
C40T (except Part No. 22762)	22A
C40T (Part No. 22762)	18A

Method of adjustment is similar to voltage regulator and cut-out.

In the case of boxes under warranty where the cover should *not* be removed, the following alternative methods of checking may be used.

Switch on headlights and leave on for 5 minutes before starting engine.

Still with the headlights on, start and run engine at above charging speed, check ammeter reading. If incorrect to specifications quoted, replace box.

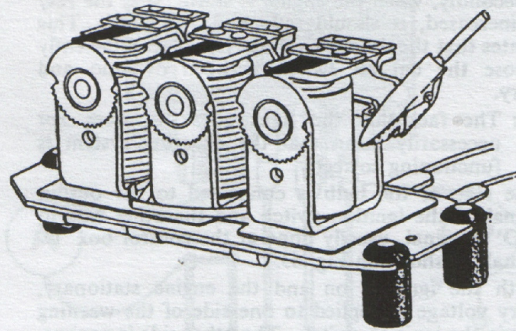

Fig. 66 Checking the current regulator setting

**TEST 4. Checking Voltage Drop on Supply Line**

Remove the 'D' lead from the dynamo terminal and connect the ammeter into the circuit, see Fig. 67.

Connect the voltmeter between the dynamo 'D' lead and the battery supply terminal at the starter solenoid. Start and run the engine at charging speed until the ammeter reads 10A. At this point the voltmeter reading should not exceed 0.75V.

A higher reading than 0.75V indicates a high resistance in the insulated line.

**CONCLUSION**

Having obtained an idea of the various forms of generator control units and their working, it may be desirable to add a note of caution.

The successful servicing of these important components depends on making adjustments which are stable and permanent. Only a limited amount of work can be successfully executed in the general garage. If, for example, a control unit will not respond to the adjustments outlined, it should be replaced.

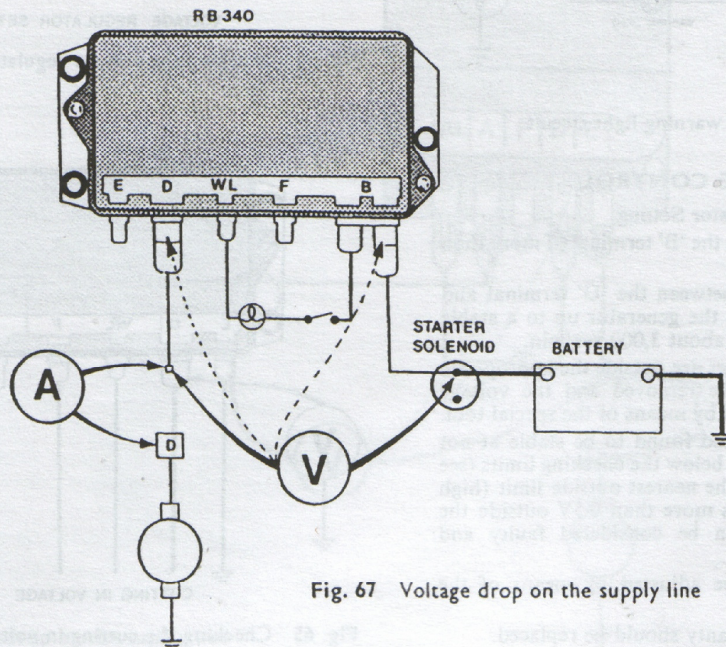
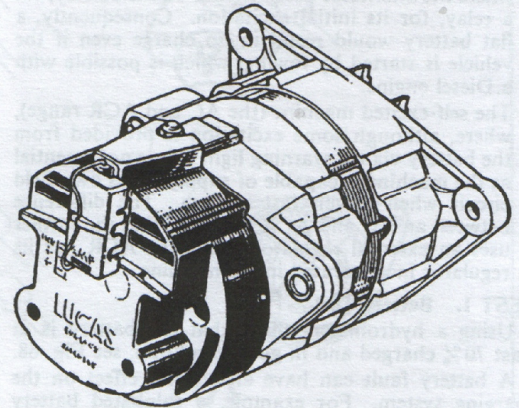
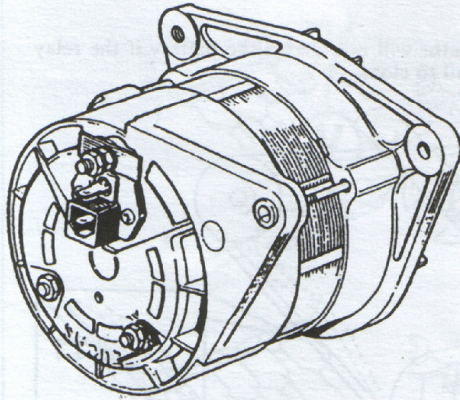

Fig. 67 Voltage drop on the supply line

# ALTERNATORS



## INTRODUCTION

The alternator produces alternating current which is converted to direct current before being connected to the vehicle electrical system. In this respect the alternator and dynamo are similar, since the current generated in the armature windings of the dynamo is also alternating current which has to be converted to direct current before it can be used to charge the vehicle battery.

In the case of the dynamo, the alternating current is rectified by means of a commutator and brush-gear. The output of the alternator is rectified by semi-conductor devices, which allow electricity to flow in one direction only—and so supply uni-directional current to the vehicle electrical system.

The alternator output is controlled by a voltage regulator which is completely electronic, having no vibrating contacts. The use of printed circuits and

semi-conductor devices make this type of regulator more reliable and more stable than the conventional type of mechanical regulator used with dynamos.

No cut-out is required with this type of control since the semi-conductor devices prevent reverse currents from flowing. Also, the self-regulating properties of the alternator limit the output current to a safe value so that there is no need for a current regulator.

The latest alternators represent an important development in design, as the alternator and voltage regulator are combined to form a single unit, the regulator being housed within the end cover of the alternator. This simplifies the charging circuit without changing the operating principles.

Alternator design and construction allows a wider speed range and utilisation of higher pulley ratios, which in turn enables the battery to be charged at lower engine speeds. This can be beneficial in high density traffic conditions and on modern vehicles with high electrical loads.

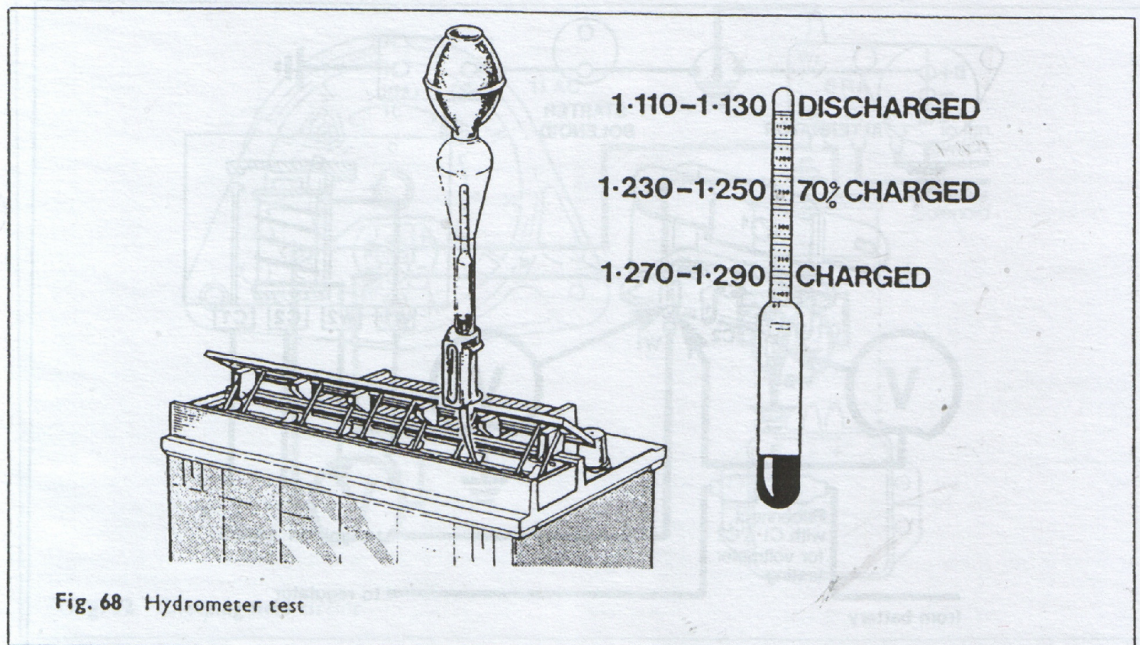

Fig. 68 Hydrometer test

In this section we shall discuss the test procedure for two types of A.C. system:

1. The battery-excited machine (10AC and 11AC), where the alternator field depends on the battery, via a relay, for its initial excitation. Consequently, a flat battery would result in no charge even if the vehicle is started by towing, which is possible with a Diesel engine.
2. The self-excited machine (the AC and ACR range), where, although some excitation is provided from the battery via the warning light this is not essential as the machine is capable of supplying its own field circuit when driven fast enough. The difference between an AC and ACR system is that the former uses an external regulator whilst the ACR has its regulator incorporated in the machine.

#### TEST 1. Battery Test

Using a hydrometer, check that the battery is at least 70% charged and in good condition, see Fig. 68.

A battery fault can have an adverse effect on the charging system. For example, a sulphated battery will produce a low charge rate while a battery with a shorted cell will produce a high charge rate.

#### TEST 2. Drive Belt Tension

Allow 13-19 mm (0.5"-0.75") play when moderate finger pressure is applied to the longest run of belt. See Fig. 69.

The alternator will not charge the battery if the drive belt is too slack. On the other hand, an excessively tight belt may damage the bearings.

If the belt is worn or oily, it should be replaced with a premium grade type.

#### TEST 3. Connections

Ensure that all leads are in position.

#### TEST 4. Checking 6RA Relay

The purpose of the 6RA relay is to de-energise the alternator field winding, when the engine is stationary.

The relay is connected to the ignition switch so that it operates only when the ignition is switched 'on'. The rotor field is completed by contacts 'C1' and 'C2'.

The alternator will not charge the battery if the relay contacts fail to close.

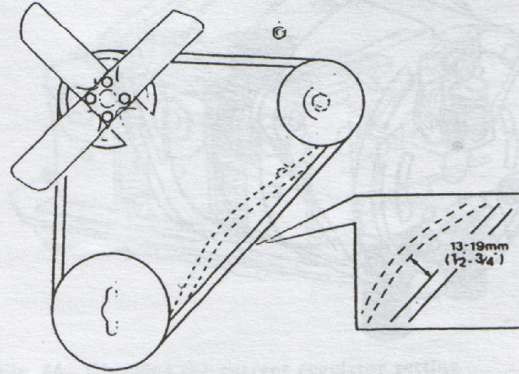

Fig. 69 Drive belt tension

- (a) With the engine stationary, disconnect the battery earth cable and connect an ammeter in the alternator main output lead as shown in Fig. 70.
- (b) Remove the cables from terminals 'C1' and 'C2' at the relay and link together. Re-connect the battery earth cable, switch on the ignition and run the engine at 1,500 rev/min.
- (c) If the ammeter now shows a charge, the previous failure was due to the relay, or its associated wiring, connections etc.
- (d) Connect voltmeter across 'W1' and 'W2'. The voltmeter should read battery voltage if the relay has a good earth and supply. If no reading, proceed to (e).
- (e) Check relay earth connection by connecting the voltmeter between 'W1' (white lead) and a good earth. The voltmeter should read battery voltage. If not, check that the supply lead (via ignition switch) and its connections are in good condition.

Note: Some vehicles are fitted with a pressure switch in the relay earth lead. Connect a temporary

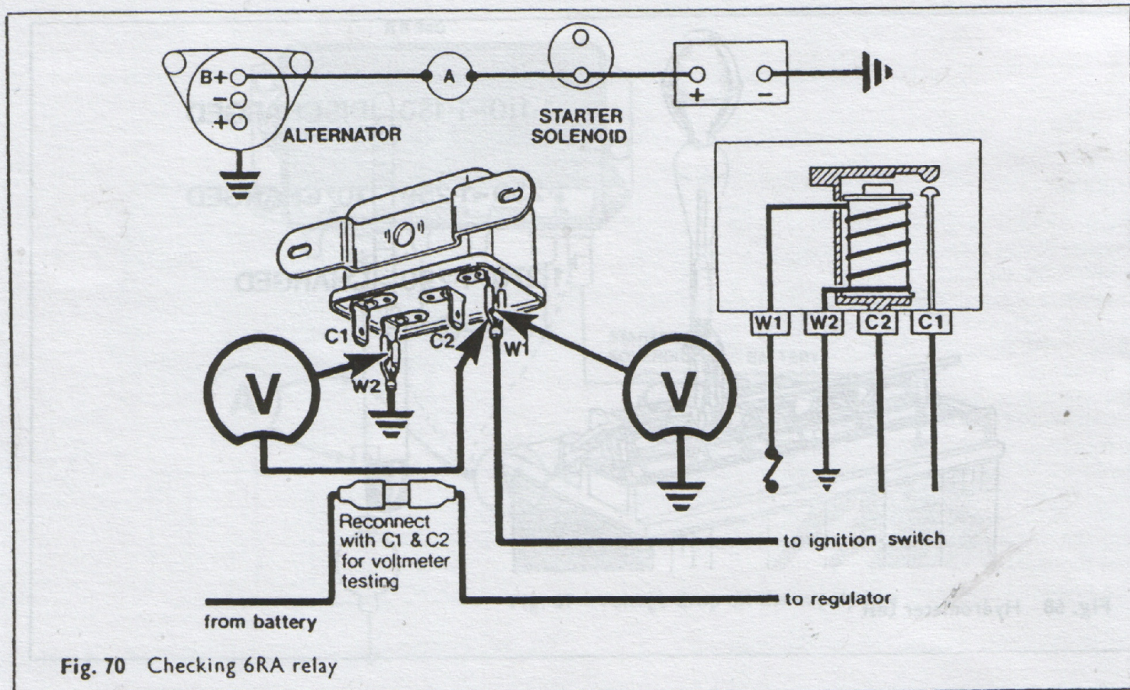

Fig. 70 Checking 6RA relay

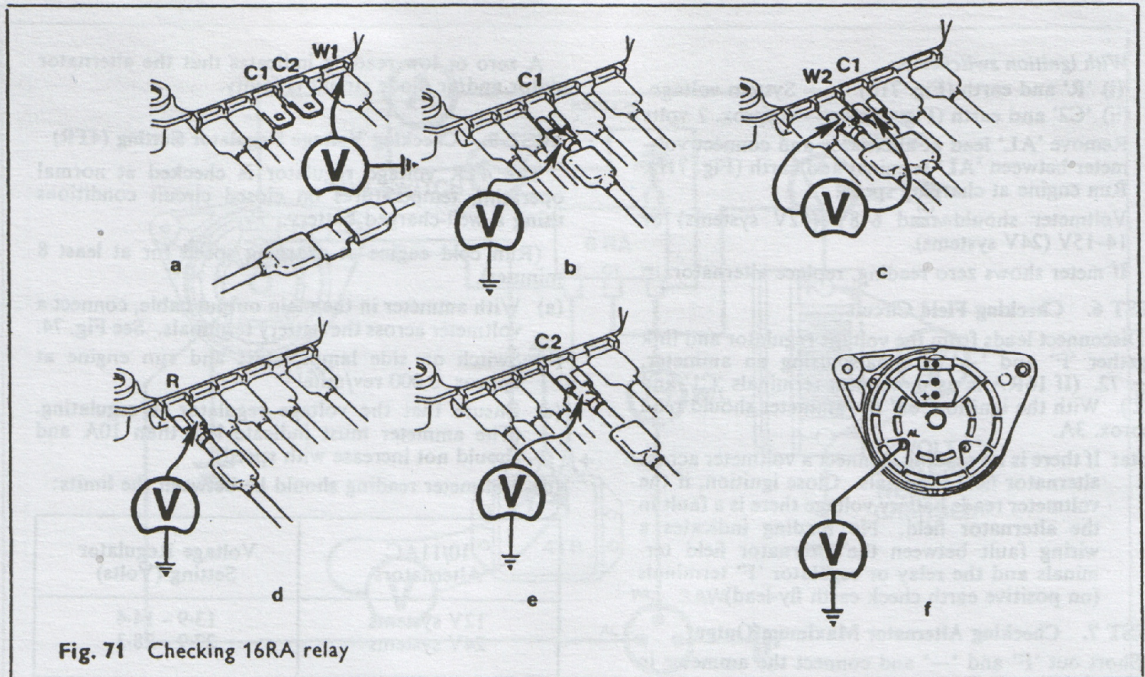

Fig. 71 Checking 16RA relay

lead between terminal 'W2' on the relay and earth. If voltmeter now reads battery voltage, the pressure switch is probably faulty.

**TEST 5. Checking 16RA Relay**

The 16RA relay is checked in a similar manner to the 6RA. The various checks are shown in Fig. 71.

Connect ammeter in the main charging lead to the battery.

(a) Remove connections 'C1' and 'C2' and link together (Fig. 71a). Connect voltmeter between 'W1' and earth.

Run alternator at charging speed (1,500 engine rev/min).

Ammeter should now show a charge and the voltmeter 6-8V.

Note: 1. If the alternator stops charging when 'C1' and 'C2' are re-connected to the relay, proceed to Test (b).

2. If ammeter indicates a charge but voltmeter reads zero, proceed to Test (c).

(b) The following circuit checks *must* be carried out before condemning the relay.

Connect voltmeter between the following points:

*Results*

- (i) 'C1' and earth (Fig. 71b) — System voltage
- (ii) 'C1' and 'W2' (Fig. 71c) — System voltage

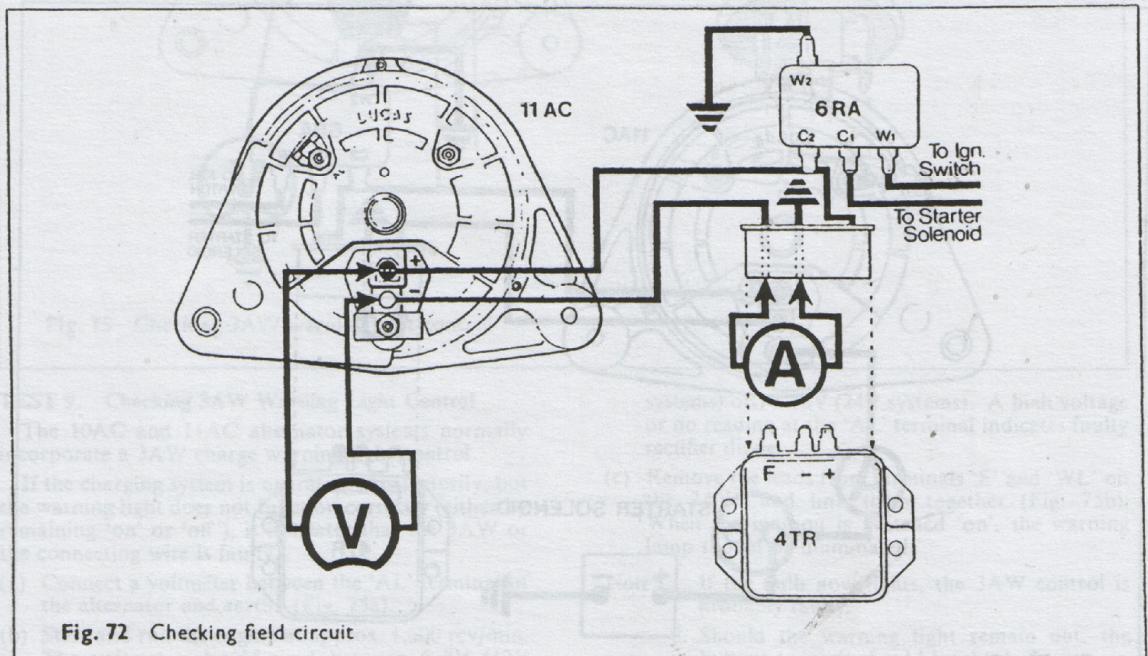

Fig. 72 Checking field circuit

With ignition switched on

- (i) 'R' and earth (Fig. 71d) — System voltage
- (ii) 'C2' and earth (Fig. 71e) — Approx. 2 volts
- (c) Remove 'AL' lead at alternator and connect voltmeter between 'AL' terminal and earth (Fig. 71f). Run engine at charging speed.

Voltmeter should read 6–8V (12V systems) or 14–15V (24V systems).

If meter shows zero reading, replace alternator.

**TEST 6. Checking Field Circuit**

Disconnect leads from the voltage regulator and link together 'F' and '-' terminals, using an ammeter, Fig. 72. (If 16RA is used, connect terminals 'C1' and 'C2'). With the ignition 'on' the ammeter should read approx. 3A.

**Note:** If there is no reading, connect a voltmeter across alternator field terminals. Close ignition, if the voltmeter reads battery voltage there is a fault in the alternator field. No reading indicates a wiring fault between the alternator field terminals and the relay or regulator 'F' terminals (on positive earth check earth fly-lead).

**TEST 7. Checking Alternator Maximum Output**

Short out 'F' and '-' and connect the ammeter in the main output lead at the alternator or starter solenoid, as shown in Fig. 73. Run the engine at approx. 3,000 rev/min. The ammeter-reading should be:

Alternator Model	Ammeter Reading
10AC	35A
11AC	45A
11AC (23580) (23633)	60A
11AC (24V)	23A

A zero or low reading indicates that the alternator stator and/or diode circuit is faulty.

**TEST 8. Checking Voltage Regulator Setting (4TR)**

The 4TR voltage regulator is checked at normal operating temperatures on closed circuit conditions using a well-charged battery.

(Run cold engine at charging speed for at least 8 minutes).

- (a) With ammeter in the main output cable, connect a voltmeter across the battery terminals. See Fig. 74.
- (b) Switch on side lamps, start and run engine at approx. 3,000 rev/min.
- (c) Ensure that the voltage regulator is regulating. (The ammeter must indicate less than 10A and should not increase with speed).
- (d) Voltmeter reading should be between the limits:

10/11AC Alternators	Voltage Regulator Setting (Volts)
12V systems	13.9 – 14.4
24V systems	27.9 – 28.3

- Note:**
1. A low reading indicates a faulty 4TR unit.
  2. If the reading is higher than the limits or unstable, the test should be repeated with the voltmeter connected across the '+' and '-' terminals of the 4TR unit.
  3. A high reading indicates a faulty 4TR unit. A correct reading denotes a high resistance in the sensing circuit which must be located and remedied.
  4. An unstable reading is due either to a high resistance in the circuit (which must be checked) or a faulty 4TR unit.

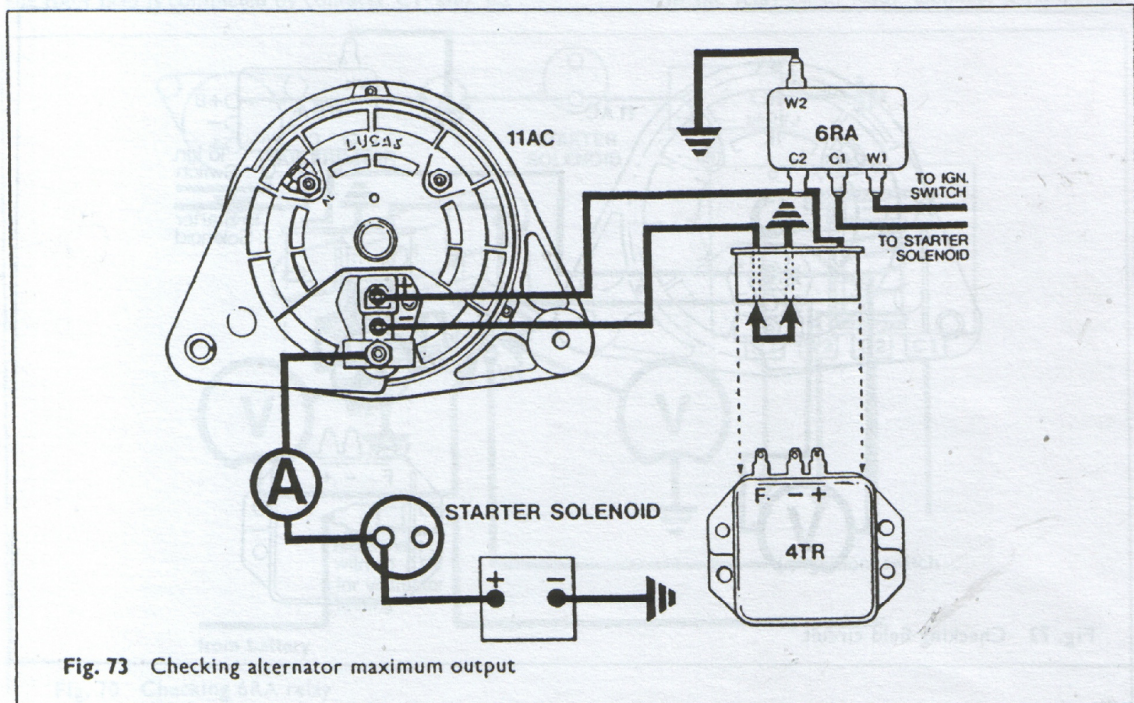

Fig. 73 Checking alternator maximum output

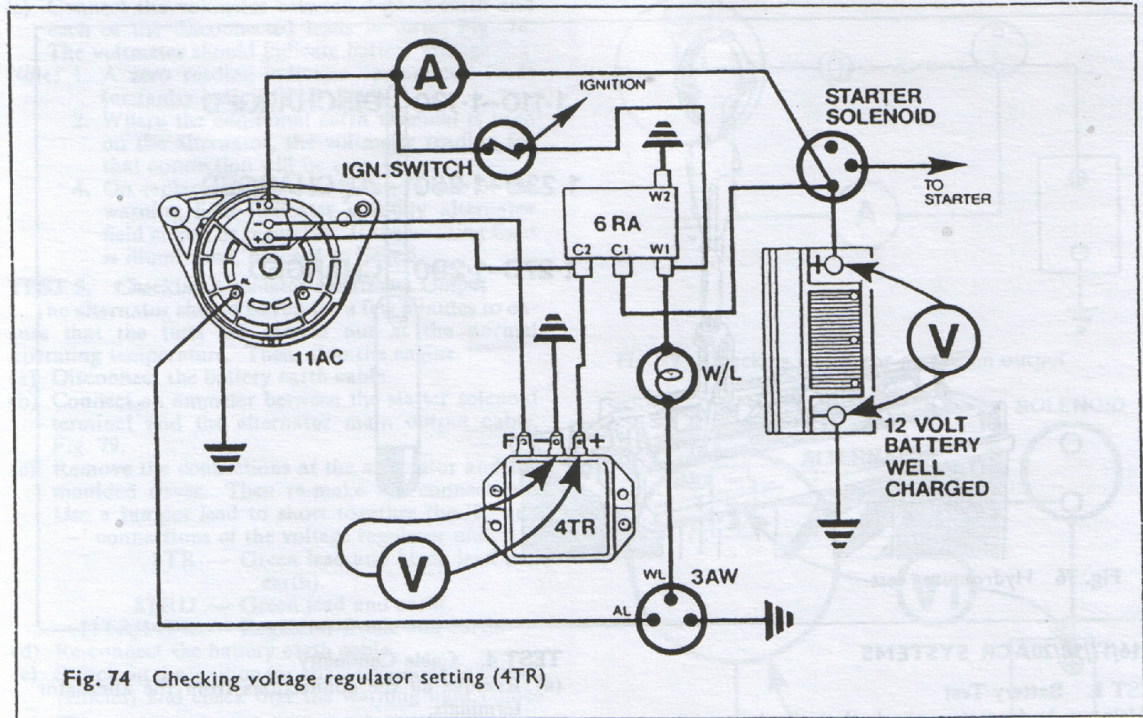

Fig. 74 Checking voltage regulator setting (4TR)

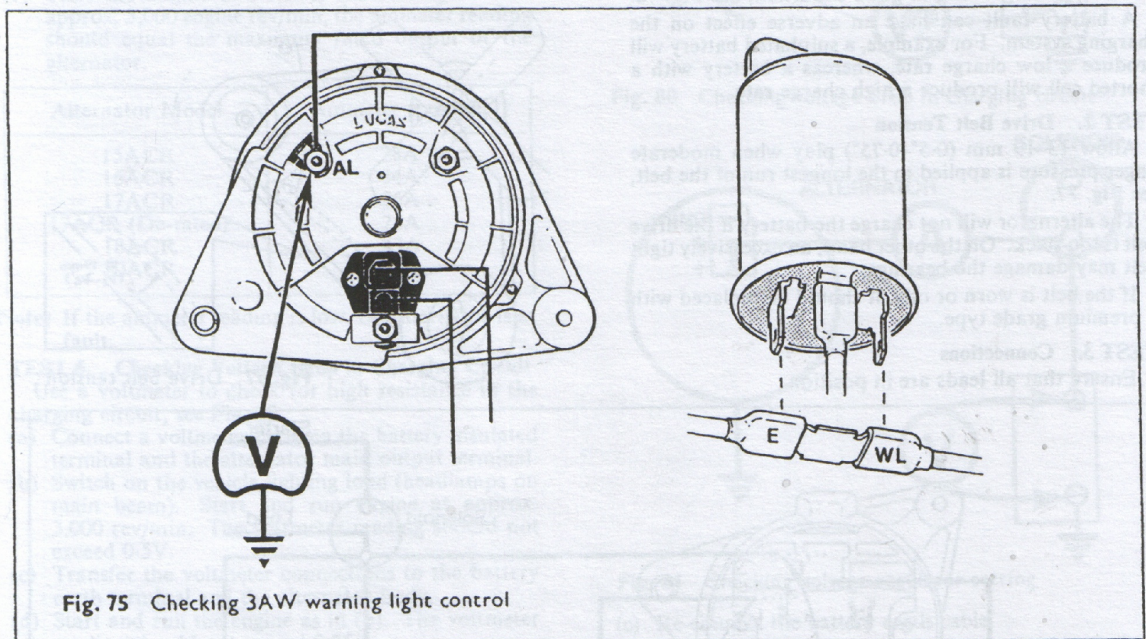

Fig. 75 Checking 3AW warning light control

**TEST 9. Checking 3AW Warning Light Control**

The 10AC and 11AC alternator systems normally incorporate a 3AW charge warning light control.

If the charging system is operating satisfactorily, but the warning light does not function correctly (either by remaining 'on' or 'off'), it indicates that the 3AW or the connecting wire is faulty.

- (a) Connect a voltmeter between the 'AL' terminal of the alternator and earth. (Fig. 75a).
- (b) Start and run the engine at approx. 1,500 rev/min. The voltmeter should read between 6-8V (12V

systems) or 14-15V (24V systems). A high voltage or no reading at the 'AL' terminal indicates faulty rectifier diode.

- (c) Remove the leads from terminals 'E' and 'WL' on the 3AW, and link them together (Fig. 75b). When the ignition is switched 'on', the warning lamp should be illuminated.

- Note:**
- 1. If the bulb now lights, the 3AW control is probably faulty.
  - 2. Should the warning light remain out, the bulb and circuit should be checked.

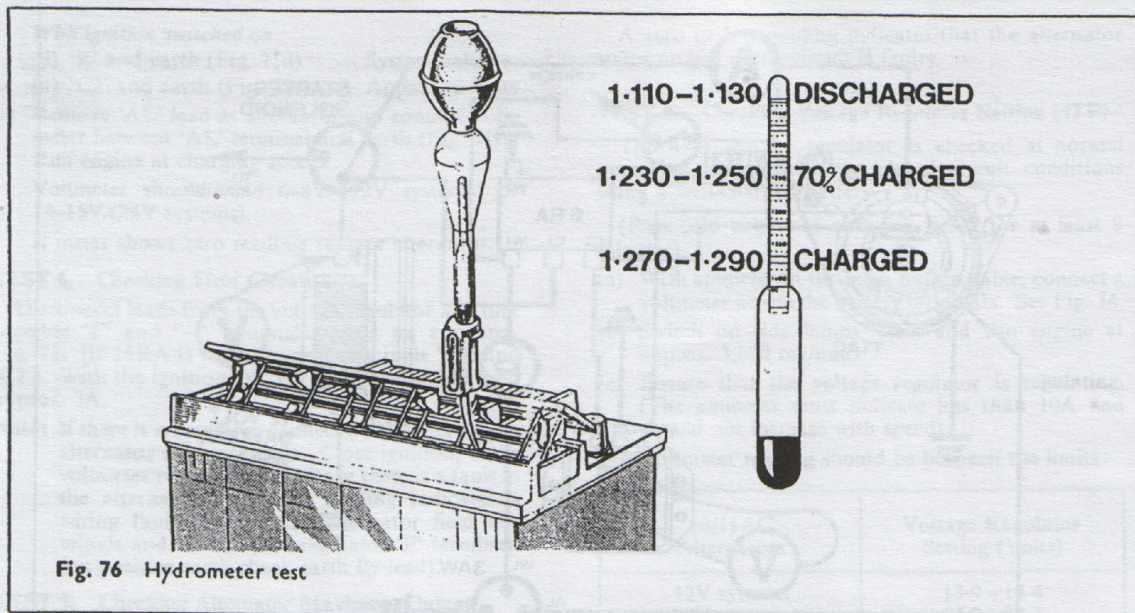

**15/16/17/18/20ACR SYSTEMS**

**TEST 1. Battery Test**

Using a hydrometer, check that the battery is at least 70% charged and in good condition, see Fig. 76.

A battery fault can have an adverse effect on the charging system. For example, a sulphated battery will produce a low charge rate, whereas a battery with a shorted cell will produce a high charge rate.

**TEST 2. Drive Belt Tension**

Allow 13-19 mm (0.5"-0.75") play when moderate finger pressure is applied to the longest run of the belt, see Fig. 77.

The alternator will not charge the battery if the drive belt is too slack. On the other hand, an excessively tight belt may damage the bearings.

If the belt is worn or oily, it should be replaced with a premium grade type.

**TEST 3. Connections**

Ensure that all leads are in position.

**TEST 4. Cable Continuity**

(a) Remove all the connections from the alternator terminals.

(b) Switch on the ignition.

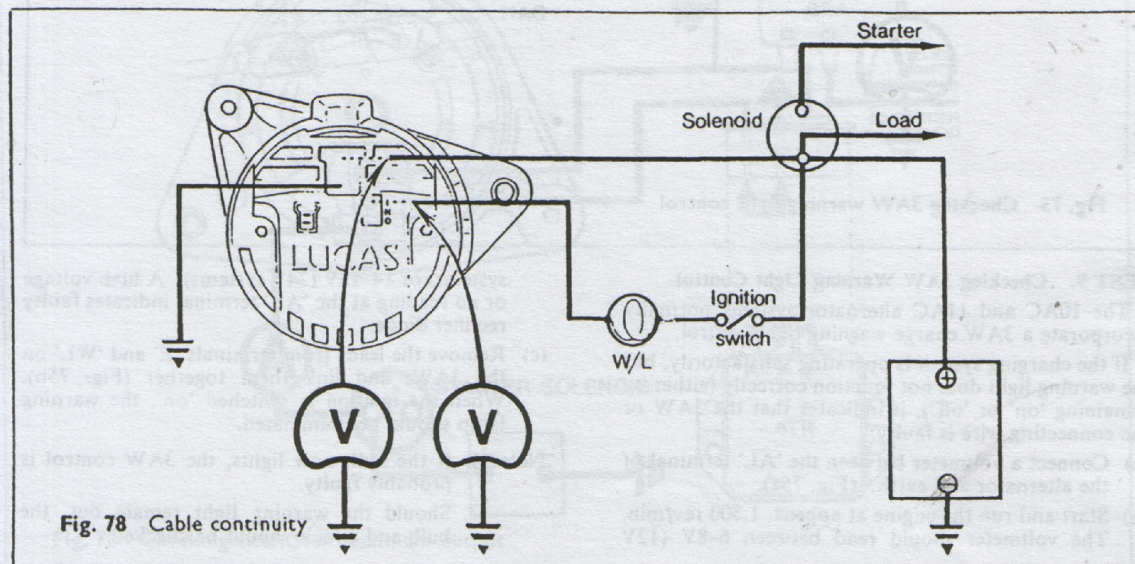
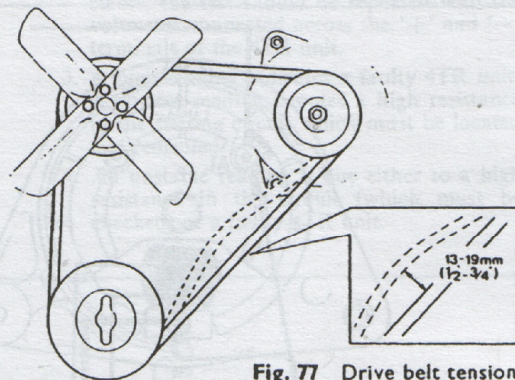

- (c) Connect the voltmeter between a good earth and each of the disconnected leads in turn. Fig. 78. The voltmeter should indicate battery voltage.
- Note:** 1. A zero reading indicates open-circuit leads (or faulty bulb if 'IND' lead).
2. Where the additional earth terminal is used on the alternator, the voltmeter reading for that connection will be zero.
4. On replacing the connections, failure of the warning light indicates a faulty alternator field circuit or regulator. If the warning light is illuminated, proceed to Test 5.

**TEST 5. Checking Alternator Maximum Output**

The alternator should be run for a few minutes to ensure that the tests are carried out at the normal operating temperature. Then, stop the engine.

- (a) Disconnect the battery earth cable.
- (b) Connect an ammeter between the starter solenoid terminal and the alternator main output cable, Fig. 79.
- (c) Remove the connections at the alternator and the moulded cover. Then re-make the connections. Use a jumper lead to short together the 'F' and '-' connections of the voltage regulator unit.
- 8TR — Green lead and black lead (i.e. earth).
- 8TRD — Green lead and earth.
- 11TR/14TR — Regulator frame and earth.
- (d) Re-connect the battery earth cable.
- (e) Switch on the ignition (or auxiliary switch for diesel vehicles) and check that the warning light comes on.
- (f) Start the engine and slowly increase speed. At approx. 3,000 engine rev/min, the ammeter reading should equal the maximum rated output of the alternator.

Alternator Model	Ammeter Reading
15ACR	28A
16ACR	34A
17ACR	36A
17ACR (De-rated)	25A
18ACR	43A
20ACR	66A

**Note:** If the ammeter reading is low, the alternator is at fault.

**TEST 6. Checking Voltage Drop in Charging Circuit**

Use a voltmeter to check for high resistance in the charging circuit, see Fig. 80.

- (a) Connect a voltmeter between the battery insulated terminal and the alternator main output terminal.
- (b) Switch on the vehicle lighting load (headlamps on main beam). Start and run engine at approx. 3,000 rev/min. The voltmeter reading should not exceed 0.5V.
- (c) Transfer the voltmeter connections to the battery earth terminal and the alternator body.
- (d) Start and run the engine as in (b). The voltmeter reading should not exceed 0.25V.

**Note:** If the readings are higher, then there is a high resistance in the circuit which must be located and rectified.

**TEST 7. Checking Voltage Regulator Setting**

Before checking the voltage regulator setting, it is essential that a battery in a well-charged condition is fitted to the vehicle.

- (a) Disconnect the battery earth cable.
- (b) Connect an ammeter between the starter solenoid terminal and the alternator main output cable. Connect a voltmeter across the battery terminals, Fig. 81.

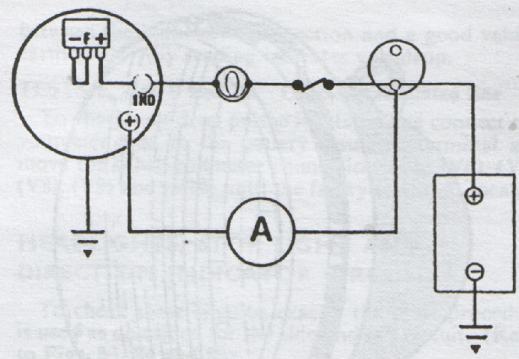

Fig. 79 Checking alternator maximum output

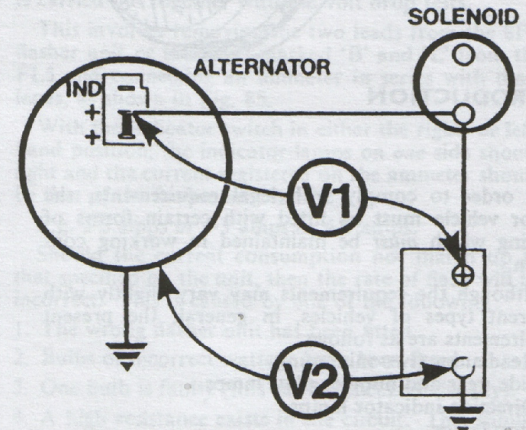

Fig. 80 Checking voltage drop in charging circuit

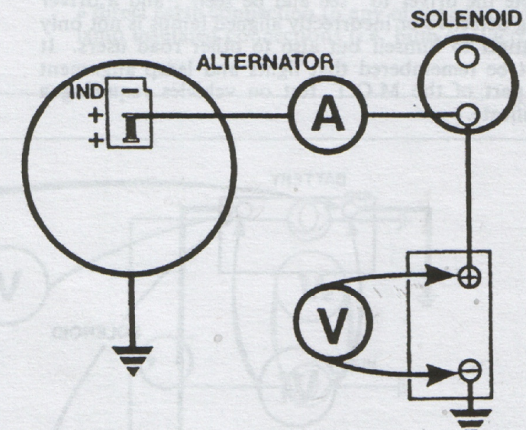

Fig. 81 Checking voltage regulator setting

- (c) Re-connect the battery earth cable.
- (d) Start and run the engine at approx. 3,000 rev/min until the ammeter reading is less than 10 amperes. The voltmeter reading should be within the limits 13.6-14.4V.

If the reading is unstable or outside the specified limits, the voltage regulator is faulty and should be replaced.

**Note:** When checking battery-sensed alternators, first check for high resistance in sensing lead. Connect known good lead between battery '+ve' terminal and alternator terminal 'B+' and repeat TEST 7.

# LIGHTING

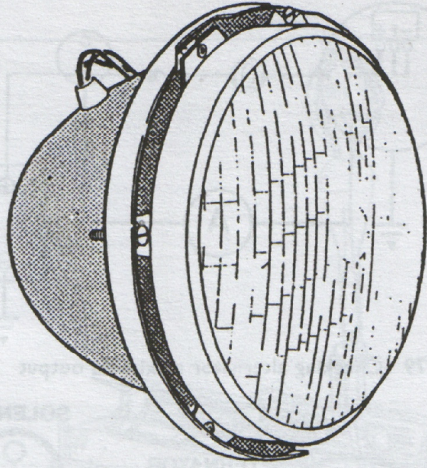

## INTRODUCTION

In order to comply with legal requirements, the motor vehicle must be fitted with certain forms of lighting which *must* be maintained in working condition.

Although the requirements may vary slightly with different types of vehicles, in general, the present requirements are as follows:

1. Headlamps (two minimum).
2. Side, rear and number plate lamps.
3. Direction indicator lamps.
4. Stop lamps.

Apart from the legal aspect, efficient lighting will enable the driver to "see and be seen", and a driver using defective or incorrectly aligned lamps is not only a danger to himself but also to other road users. It must be remembered that lights and lamp alignment are part of the M.O.T. test on vehicles requiring a certificate.

Additional lamps may be fitted to a vehicle, but they must comply with the regulations governing those particular lamps.

For example, any additional lamps fitted to the front of a vehicle where the mounting height exceeds 24" from the ground to the centre of the lamps automatically become headlamps unless they are used in conditions of fog or falling snow. As such, they must comply with requirements applicable to headlamps.

When testing lighting circuits the "volt drop" principle will be used. This will involve checking the "supply voltage available" under load (at the battery) then the voltage available at the actual lamp involved. Where the difference in voltage exceeds the permitted limits the voltmeter will be connected in parallel with both the supply and return sides of the circuit to determine where the fault exists. The exact procedure will be stated in this section.

In the case of direction indicator circuits, it will be necessary to use an ammeter in addition to the voltmeter, as the operation of the "flasher" unit is dependent on current consumption.

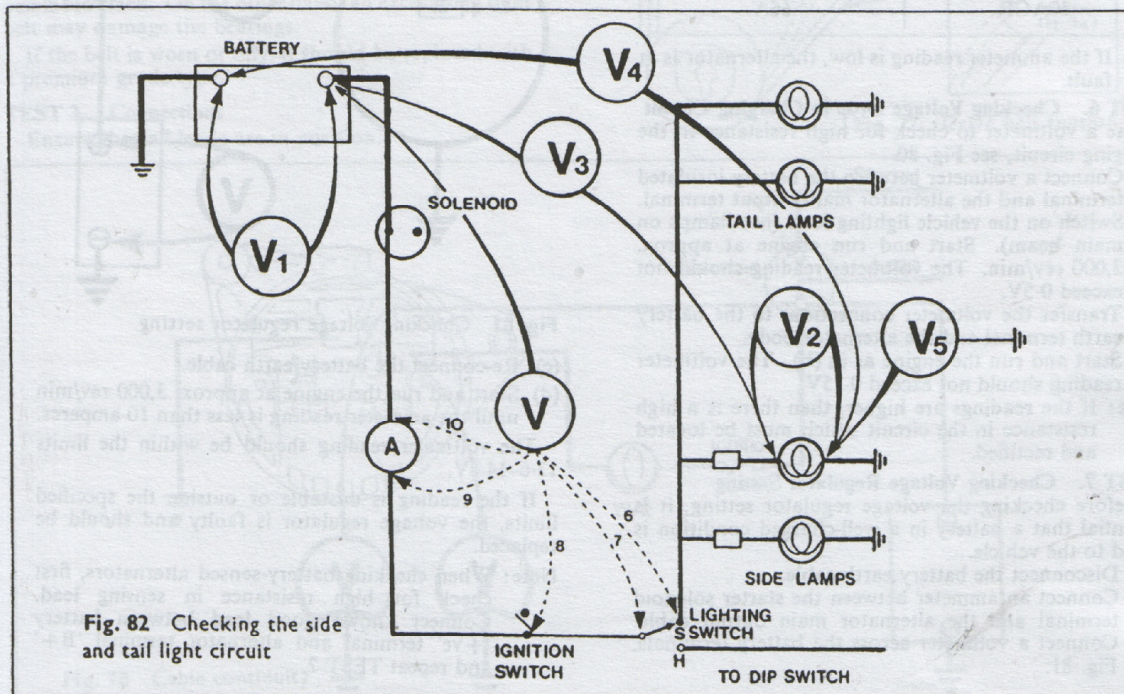

Fig. 82 Checking the side and tail light circuit

## SIDE AND TAIL LIGHT CIRCUIT

### ALL TESTS WITH SIDE AND TAIL LIGHTS SWITCHED ON.

Refer to Fig. 82 for voltmeter positions.

#### TEST 1. Voltage at the Battery under Load

Connect voltmeter (V1) across the battery terminals and note the reading.

#### TEST 2. Voltage at bulb connections

Connect the voltmeter across the bulb connections as (V2). Note the reading. The difference in reading (volt drop) should not exceed 10% of the system voltage. If the volt drop is excessive, proceed to Test 3 (insulated line).

#### TEST 3. Voltage drop on insulated line

Connect one side of voltmeter to the battery insulated terminal and the other side to the bulb insulated connection as (V3).

Note the reading.

#### TEST 4. Voltage drop on earth line

Connect one side of the voltmeter to the battery earth terminal and the other side to the bulb earth connection as (V4).

Note the reading.

If the total of the readings for Tests 3 and 4 exceeds 10% of the system voltage, a high resistance exists on either the insulated or earth lines or possibly both.

Bearing in mind that the total volt drop allowed is 10% (approx. 1.2V for a 12 volt system), it is permissible to have all this drop on one line or the other or as a combination of both lines.

#### TEST 5. Bulb earth connection

If the volt drop figure on the earth side is the higher, it is probably due to a bad connection between the lamp body and earth. To check, connect the voltmeter

between the bulb earth connection and a good vehicle earth (V5). Any reading indicates volt drop.

#### TESTS 6, 7, 8, 9 and 10. Checking insulated line

To check volt drop on the insulated line connect one voltmeter lead to the battery insulated terminal and move the other voltmeter connection as in (V6), (V7), (V8), (V9) and (V10) until the faulty section is located.

## HEADLIGHTS, STOP LIGHT AND DIRECTION INDICATOR CIRCUITS

To check these circuits, exactly the same procedure is used as described for the side and tail circuit. (Refer to Figs. 83, 84 and 85).

In the case of direction indicators one additional test is carried out together with the volt drop tests.

This involves removing the two leads from the 8FL flasher unit or the leads marked 'B' and 'L' from the FL5 and connecting an ammeter in series with these leads, as shown in Fig. 85.

With the indicator switch in either the right- or left-hand position, the indicator lamps on *one* side should light and the current registered on the ammeter should be that of the flasher unit rating.

E.g. 3-6 amps or 4-3 amps or 4-8 amps.

Should the current consumption not match up to that specified on the unit, then the rate of flash will be incorrect. This is caused by one of the following:

1. The wrong flasher unit has been fitted.
2. Bulbs of incorrect wattage have been fitted.
3. One bulb is faulty (this can be checked visually).
4. A high resistance exists in the circuit. This should be located using the volt drop test procedure.

Note: When testing indicator lamp circuits do *not* make a direct earth connection to any of the indicator lamp insulated connections (i.e. bulb contacts).

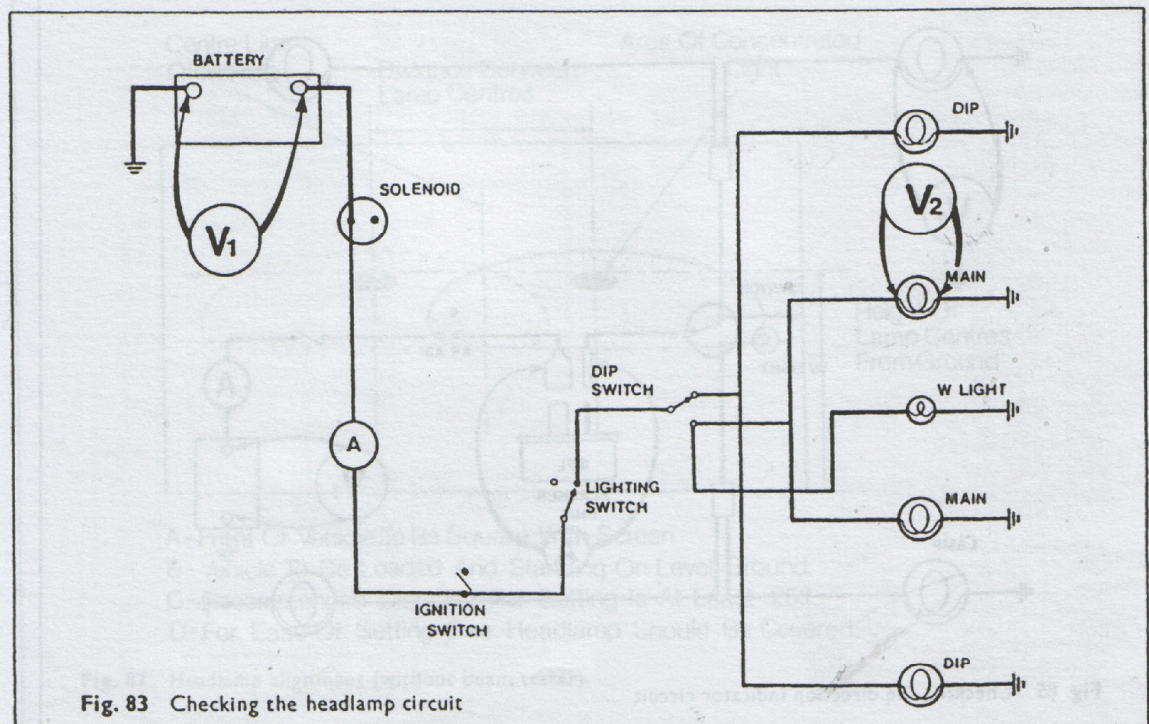

Fig. 83 Checking the headlamp circuit

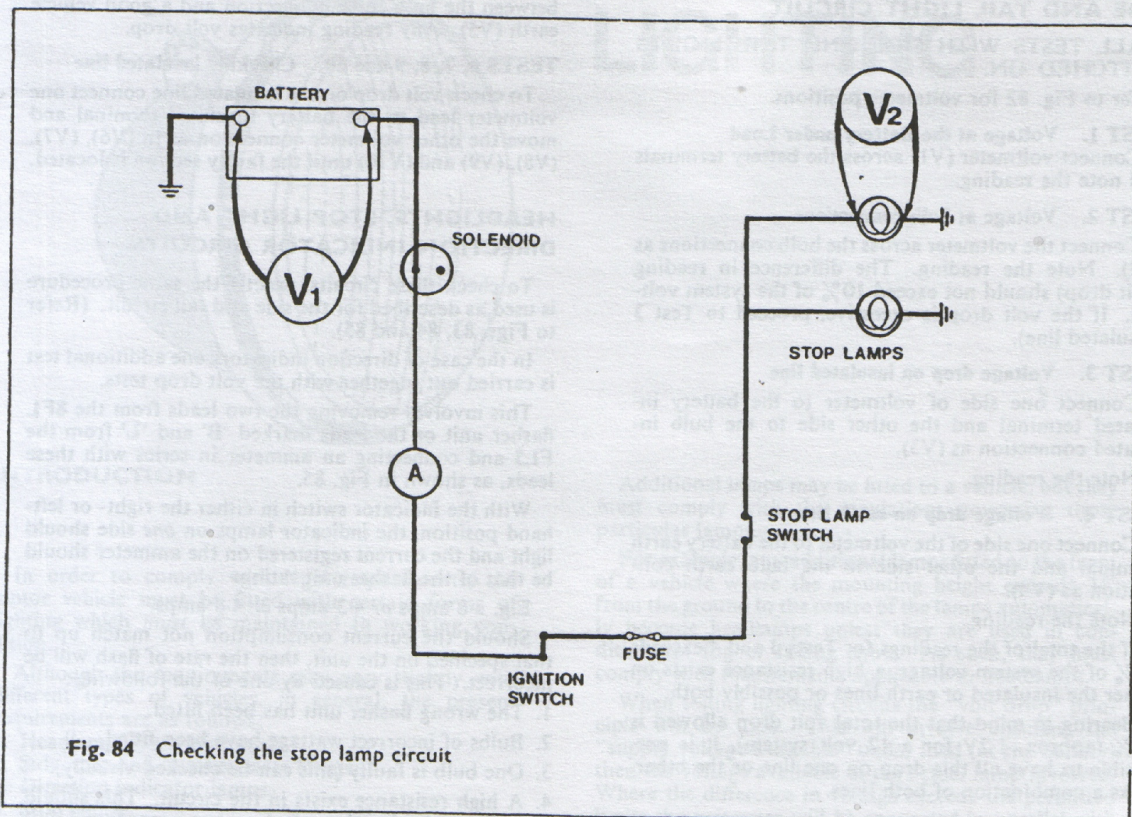

Fig. 84 Checking the stop lamp circuit

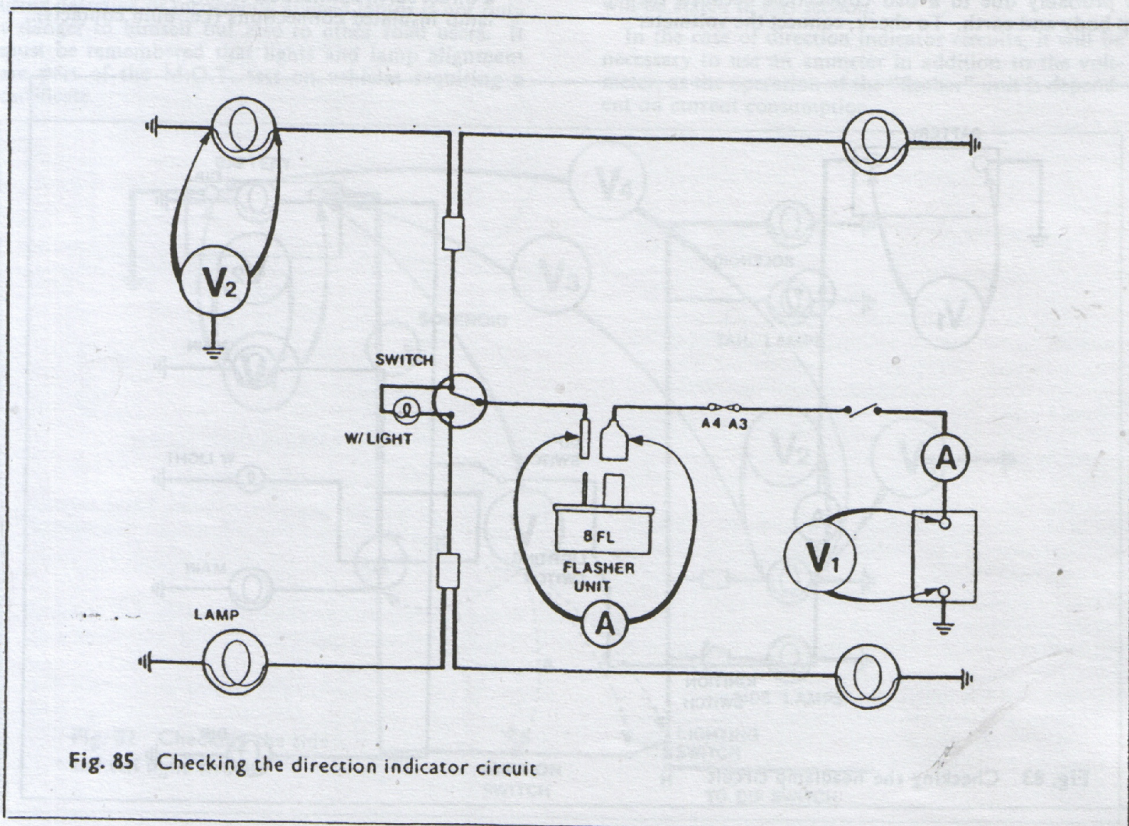

Fig. 85 Checking the direction indicator circuit

## HEADLAMP ALIGNMENT

As previously stated, the headlamps can only be fully efficient when correctly aligned.

The Lucas Beam Tester Mk. III, as shown in Fig. 86, is an instrument designed specifically for the accurate checking and alignment of all types of vehicle headlamps.

In the absence of a beamtester, an alternative but less accurate method of checking the alignment is as follows; (see Fig. 87).

Position the vehicle on a piece of level ground 25 ft. from the wall (or door) to be used as a screen. (25 ft. is required in order to obtain a suitable beam pattern). The vehicle must, as far as possible, be at right-angles to the wall (or door).

Crosses are marked on the wall corresponding to the same centres as the headlamps (i.e. same distance apart and from the ground). These marks are then used as a guide line for the correct alignment.

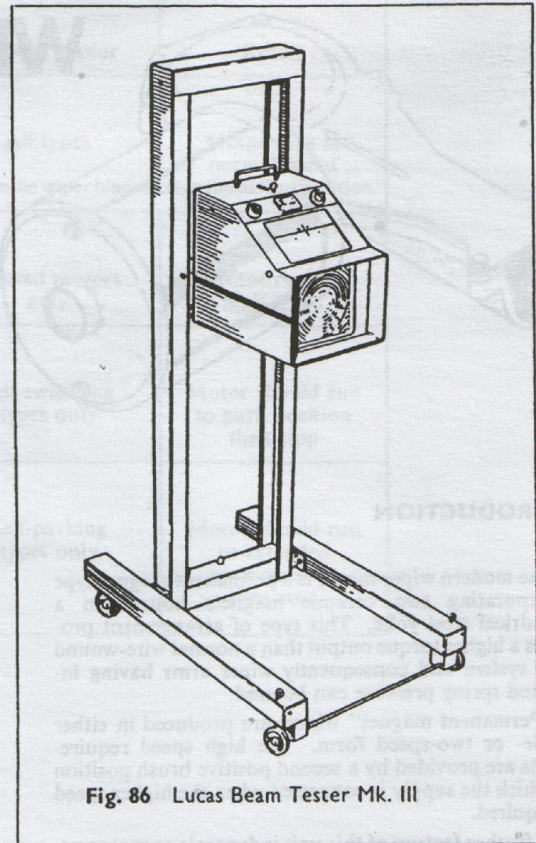

Fig. 86 Lucas Beam Tester Mk. III

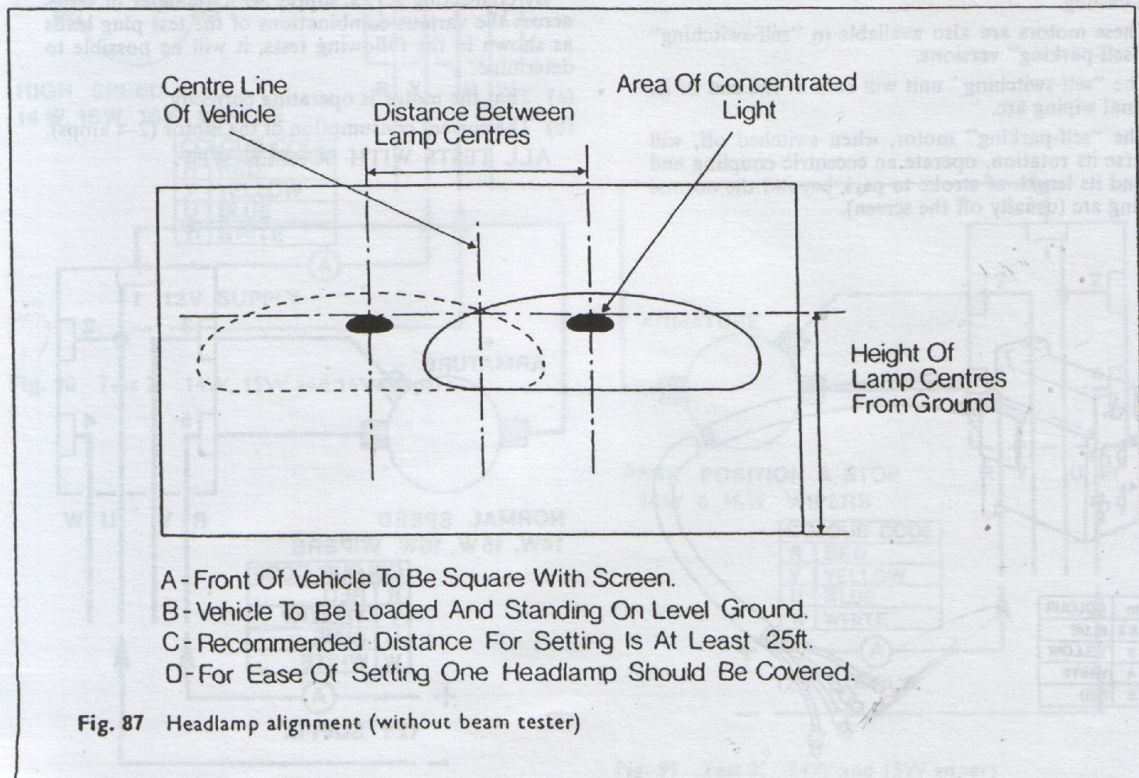
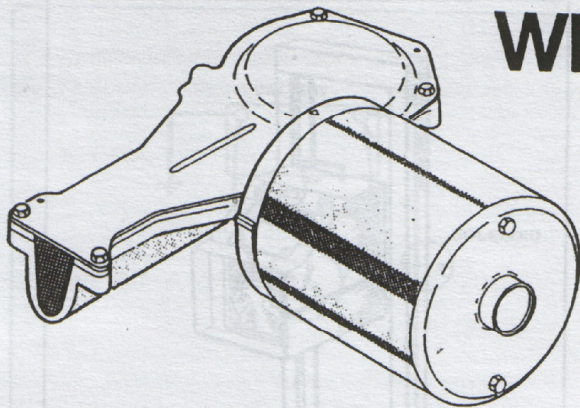

Fig. 87 Headlamp alignment (without beam tester)

# WIPER MOTORS



## INTRODUCTION

The modern wiper motor is a permanent magnet type incorporating two ceramic magnets housed in a cylindrical steel yoke. This type of arrangement produces a higher torque output than a normal wire-wound field system and consequently wiper arms having increased spring pressure can be used.

"Permanent magnet" wipers are produced in either single- or two-speed form. The high speed requirements are provided by a second positive brush position to which the supply is connected when the higher speed is required.

A further feature of this unit is dynamic or regenerative braking when the wiper switch is moved to the park position. The control for this operation is on the gearbox casting.

These motors are also available in "self-switching" or "self-parking" versions.

The "self-switching" unit will stop at the end of its normal wiping arc.

The "self-parking" motor, when switched off, will reverse its rotation, operate an eccentric coupling and extend its length of stroke to park beyond the normal wiping arc (usually off the screen).

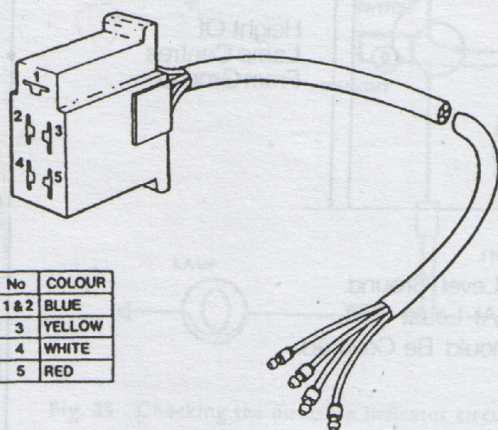

Fig. 88 Wiper motor test plug

## WIPER TEST PROCEDURE

Testing of wiper switching and circuits could become an exceedingly complex procedure. We therefore recommend a quick but simple method of establishing whether the fault lies in the wiper motor itself or the switching. This involves the use of a made-up test plug.

The plug is the common wiper plug (easily obtainable), as used on all present-day permanent magnet motors, connected with four leads, red, blue, yellow and white as shown in Fig. 88.

**Note:** Plug connections 1 and 2 should be linked at rear of plug (blue lead).

Remove the wiper motor plug on the vehicle and insert the test plug.

By connecting a 12V supply with ammeter in series across the various combinations of the test plug leads as shown in the following tests, it will be possible to determine:

- That the motor is operating correctly.
- The current consumption of the motor (2-4 amps).

ALL TESTS WITH SCREEN WET.

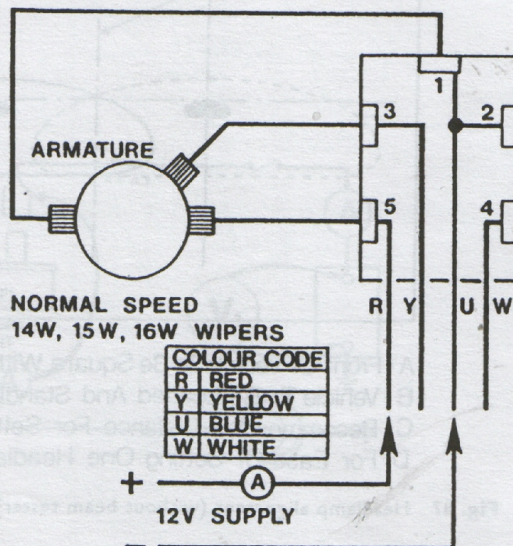

Fig. 89 Test 1. 14W, 15W and 16W wipers

Connections		Type of motor	Result
Batt. '+'	Batt. '-'		
<b>TEST 1.</b> (Fig. 89) Red	Blue	All types	Motor runs at normal speed
Do not disconnect battery supply from plug while the wiper blades are in the parked position.			
<b>TEST 2.</b> (Fig. 90) Yellow	Blue	2-speed motors only	Motor runs at high speed
<b>TEST 3.</b> (Fig. 91) Red	White	Self-switching types only	Motor should run to park position then stop
<b>TEST 4.</b> (Fig. 92) White	Red	Self-parking types only	Motor should run to extended park position then stop

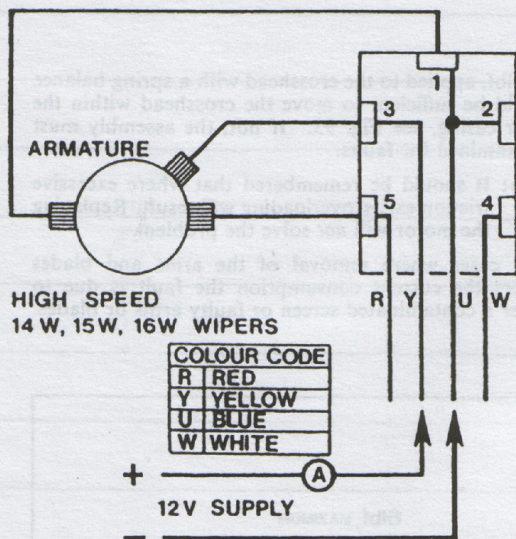

Fig. 90 Test 2. 14W, 15W and 16W wipers

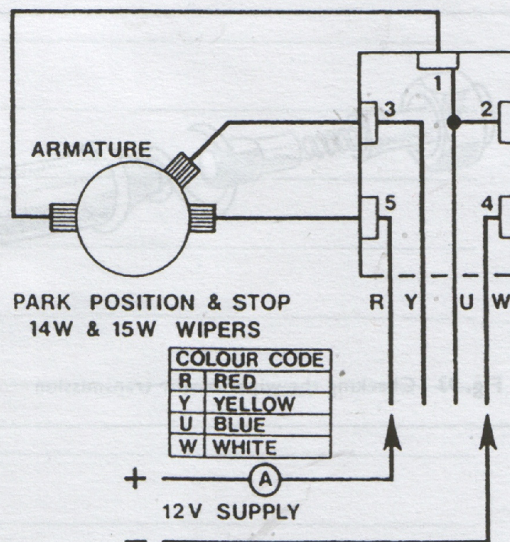

Fig. 91 Test 3. 14W and 15W wipers

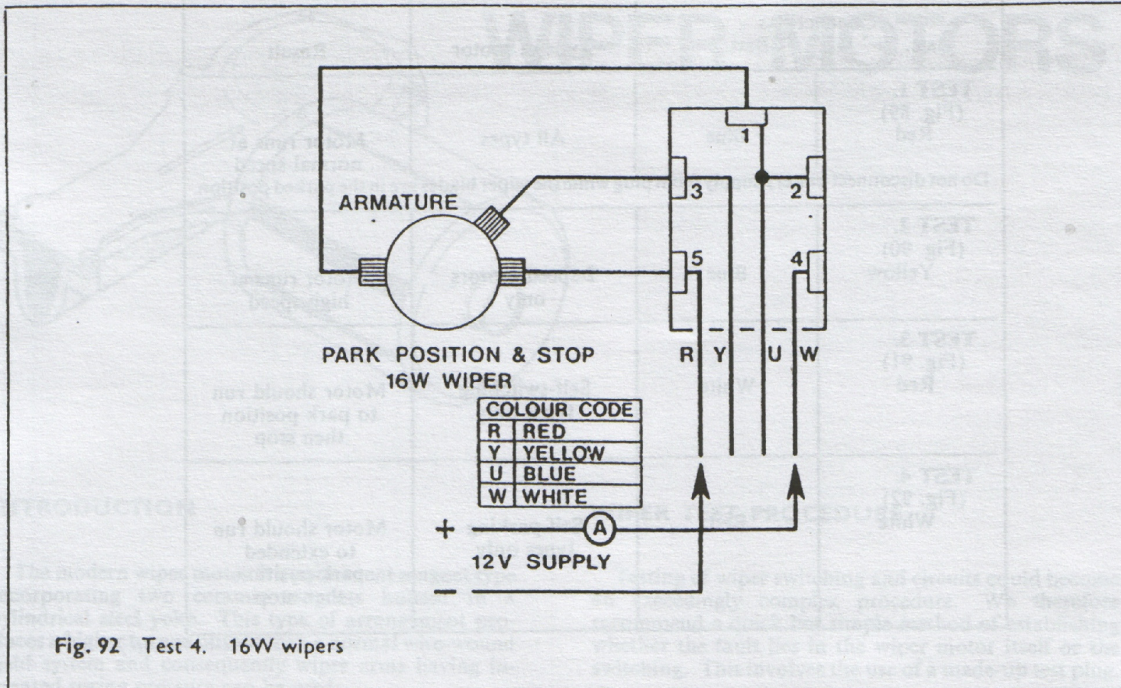

Fig. 92 Test 4. 16W wipers

If the motor fails to function in any one or more of the previous tests, a faulty motor is indicated. If, however, the motor is satisfactory, the fault lies in the switch or wiring on the vehicle.

Should the current consumption during the tests exceed 4 amps, remove the wiper arms and blades and repeat test. If current is still high this could indicate excessive friction in the rack or link drive mechanism. Disconnect the drive from the motor and again check current consumption. A high current reading now indicates a faulty motor. On the rack-type drive a pull

of 6 lbf. applied to the crosshead with a spring balance should be sufficient to move the crosshead within the outer casing, see Fig. 93. If not, the assembly must be examined for faults.

Note: It should be remembered that where excessive friction exists, overloading will result. Replacing the motor will *not* solve the problem.

In cases where removal of the arms and blades lowers the current consumption the fault is due to either a contaminated screen or faulty arms or blades.

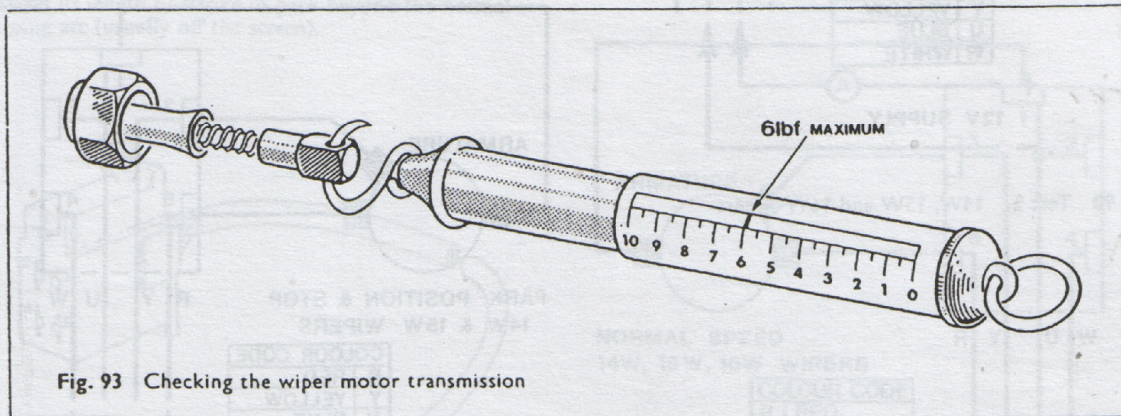

Fig. 93 Checking the wiper motor transmission