

Contents 111

<i>Description</i>	1
Repair instructions	3
Front section	3
Front mudguards	3
Front end	3
Bonnet and bonnet lock	3
Luggage compartment	4
Doors	5
Removing the front door	5
Removing the rear door	5
Removing the door handle and upholstery	6
Removing the door lock and lock handle	7
Dismantling the door handle	8
Striker block	8
Window winder and window	8
Ventilation window	9
Fitting and adjusting the lock	10
Sealing strips	12
Windscreen and rear window	13
Removing	13
Fitting	13
Fitting the trim mouldings	14
Upper trim moulding for door	14
Instrument panel	16
Interior fittings and upholstery	16
Front seat	16
Rear seat	17
Door upholstery	17
Headlining	17
Bulkhead and floor	17
Combination instrument	17
Removing the temperature and fuel gauges	17
Fuel gauge	17
Temperature gauge	17
Replacing the fuel gauge tank fitting	18
Radiator	18
Heater	18
Checking the body	20
Dimensions and weight of complete body	20

DESCRIPTION

The Volvo P 1200 has an integral body so that there is no separate chassis frame. The body is composed of a number of pressed steel plates. Each plate forms part of the supporting construction.

The body is divided up into the side sections, rear section, front section, roof section, front mudguards, doors, luggage compartment and bonnet.

The floor and frame section (illustration I) consist of a front and rear floor plate (2 and 8) and an inner cantrail (10) front and rear cross-members (1 and 6), tunnel (3) and cowl section (see illustration II). The floor plates are welded together with the rear seat support (9). The tunnel (3), which accommodates the propeller shaft, is spot-welded to the floor plates. The rear floor plate has a longitudinal reinforcing member (7) at each side at the bottom and between these a number of cross-members. One of the cross-members (6) is provided with an attachment for the rear axle tie-rod. There is a flanged hole in the rear floor plate for mounting the fuel tank, the upper part of which forms part of the floor in the luggage compartment.

The cowl section (illustration II) consists of the bulkhead (4) wheel housings (1), front upper cross-member and side plates (8 and 9) together with the lower cross-member (6 and 7). The bulkhead forms the front transverse wall of the body and is shaped with welded end pieces. Two front side members project from the front floor. At the front they are joined together by means of a cross-member and at the rear they are joined to the front cross-member under the front seats. The upper side members project from the upper corner between the bulkhead and the front pillar. These are spot-welded to the front pillar, front side plates and wheel housing plates. The front axle member and bumper support bars are attached to the side members.

The side section on the 4-door model (illustration III) consists of the front pillar (17), centre pillar (13), rear pillar (8), centre and outer cantrail (16), roof rail (4), windscreen pillar (1), rear wheel housing (6), rear mudguard (7), back-rest plate and joint plate (5).

On the 2-door model (illustration IV), there is no centre pillar and the rear mudguard (4) has

been extended. The side section consists of the front and rear door pillars (10 and 3), centre and outer cantrails (8), roof rail (1), windscreen pillar (11), rear wheel housing (5) and rear mudguard (4).

The roof section (illustration V) consists of a number of pressed steel plates. The roof plates form the upper part of the cowl, windscreen opening, the roof itself, the opening for the rear window and the upper limit of the luggage compartment.

The front mudguards and front end with bonnet make up the front sections.

The front section is bolted to the upper side members, front cross-member and front pillar. The front mudguards are pressed in one piece and bolted to the wheel housing plate.

The front end forms the front part of the front section together with the air duct to the radiator.

The bonnet is fully pivoted at the rear on two hinges. In the closed position, the bonnet is secured by a bonnet lock fitted on the front end. The lever for the bonnet lock is operated by means of a control placed underneath the instrument panel inside the car.

The doors (illustrations VI and VII) are built up of an outer and inner plate together with door arch which is flanged and spot-welded in one unit. The hinges are fitted to the inner plate. The doors are adjustable both longitudinally, vertically and transversal. The doors are provided with door stops. This consists of a flat bar attached to the door pillar and running against a roller in the door. In the open position the flat bar obstructs the roller and thus limits the movement of the door. The door locks are fitted to the doors with screws. The press button of the outside door handles operate a lever which in its turn disengages a rotating toothed roller (tumbler). The inside door handles are fitted at the remote control which is attached to the inner door plate with screws. The handle transmits the movement to the toothed roller by means of a link rod. The lock insert is fitted in the press button on the door handle. The doors can be locked from inside the car by pressing down the locking buttons.

The window winders are of the cable and chain type. The movement of the window winding

P 1200

handle is transmitted to the window itself by a cable and chain joined to a closed ring. This is mounted on two jockey pulleys and a toothed driving wheel. The lower jockey pulley is provided with a spring device for tensioning.

The luggage compartment is built up of an outer and inner plate. The loop for the locking device is fitted on the lower edge of the luggage compartment lid. The hinges are fitted at the upper edge of the luggage compartment lid. The hinges are bolted to the plate under the rear window through a reinforcing plate. The luggage compartment lid is counter-balanced with torsion rods and can be set in any position when

opening. On chassis up to chassis number 20999, the locking device is placed on the body below the lid, and on vehicles with effect from chassis number 21000, the locking device is fitted on the lid.

The bumpers are fitted on to the four support bars. The front support bars are attached to the front side members. The rear support bars are attached to the rear side members. The bumpers consist of three parts and overriders are fitted at the joints.

The body is sound-and heat-insulated by means of "waffle" paper which is stuck to the plate.

REPAIR INSTRUCTIONS

Front section

Front mudguards

The front mudguard is removed by unscrewing the following screws: the screw between the mudguard and stay on the lower side member, the screw between the mudguard and the side of the body behind the above-mentioned stay, the screws in the front side section and the screws in the upper side member. In addition, the headlight and leads must be disconnected. Concerning removing the headlight, see Part 10. Fitting is done in the reverse order.

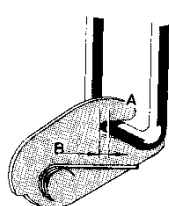

B = max. 3 mm
(0.118")

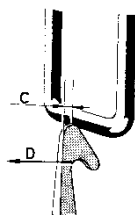

C = 2-3 mm
(0.079--0.118")

VOLVO
26802

D = min. 0.1 kg
(0.22 lb)

Fig. 1. Bonnet lock, early production.

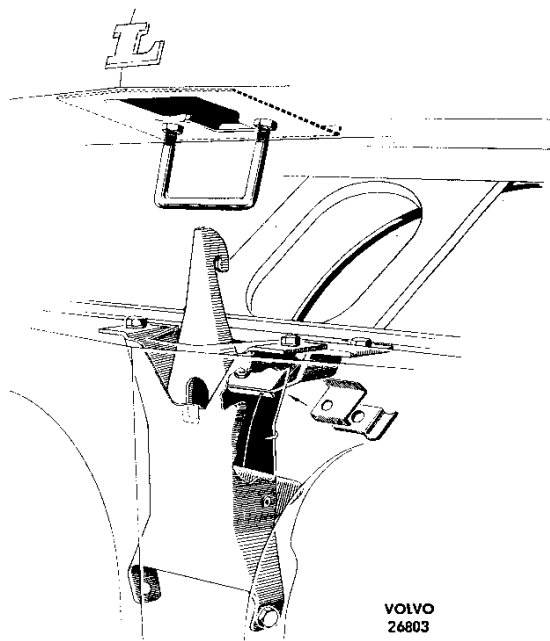

Front end

The front end is attached to the front mudguards, wheel housing plates and upper and lower cross-members.

When removing, the headlights are disconnected and the screws between the front end and mudguard below the headlights and the screws in the upper and lower cross-members, together with the screws in the wheel housing plates are removed.

Bonnet and bonnet lock

The bonnet is attached with screws in each hinge. The bonnet is removed by unscrewing the screws between the hinges and bonnet. The hinges are attached to the body with four screws each. All the holes in the hinges are oval to enable the bonnet to be adjusted.

There are two types of bonnet lock. The early production lock (up to chassis number about 10000) is illustrated in Fig. 1. The bonnet lock is adjusted as follows.

When the bonnet is locked, the locking loop should lie right inside the lock catch groove, and

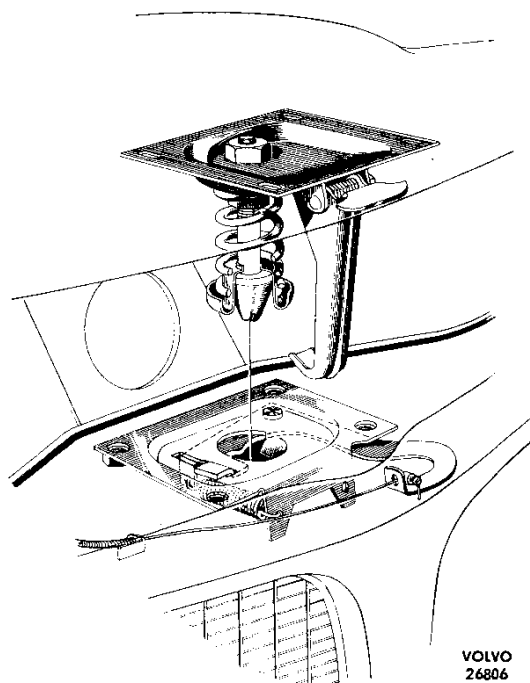

Fig. 2. Bonnet lock, late production.

the measurement B in Fig. 1 must not exceed 3 mm (0.118"). Any adjustment should be made to the locking loop. The loop should be adjusted vertically so that the gap between the bonnet and the front end of the body is 4.5 ± 1 mm (0.177 ± 0.039 "). The tension of the safety catch spring should be at least 0.1 kg (0.22 lb) in order to move it from the position of rest.

When the bonnet is closed, the locking loop should meet the safety catch as close to the pivoting pin as possible, but not so high as to cause the hook to turn back. A minor adjustment of 1–2 mm (0.04–0.08") can be made by bending the safety catch. If a larger adjustment is found to be necessary, this means that the whole locking device has been displaced. In this case the complete bonnet lock must be re-set. Late production locks with effect from chassis number about 10000 are shown in Fig. 2.

The lock can be adjusted laterally and longitudinally since the holes in the front end are larger than the diameter of the attaching bolts. The length of the latch is adjustable by means of nuts. The latch and spring are lubricated with grease.

Luggage compartment lid

The luggage compartment lid is mounted on two hinges, both of which are bolted by means of three screws to the inner plate of the lid and with two screws to the plate under the rear window.

The holes in the part of the hinges fitted in the lid are oval so as to give longitudinal adjustment. In order to obtain lateral adjustment, the holes in the body under the rear window are made larger than the diameter of the bolts. These bolts are accessible after the insulation material round

VOLVO
23234

Fig. 3. Releasing tension from the torsion rods.

VOLVO
23235

Fig. 4. Releasing the locking ring for the lock press button.

VOLVO
26210

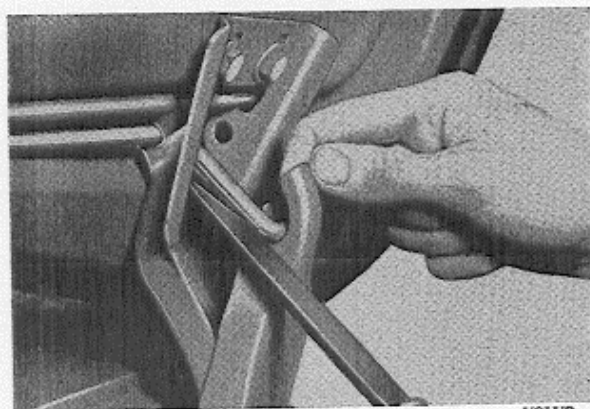
Fig. 5. Luggage compartment lid lock, late production.

- | | |
|---------------------|--------------------|
| 1. Handle | 5. Link |
| 2. Locking cylinder | 6. Guide spring |
| 3. Mechanism | 7. Attaching piece |
| 4. Rubber bushing | 8. Locking piece |

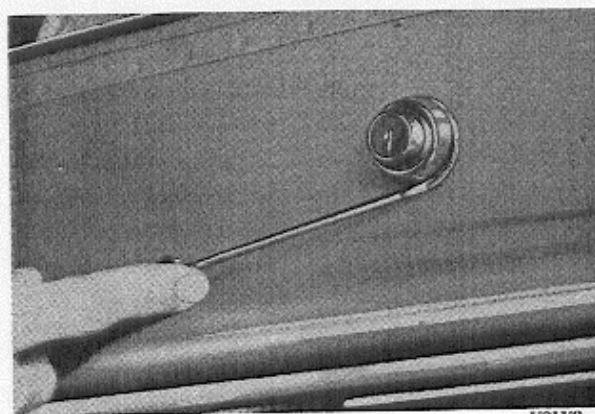
the edge of the rear window has been removed.

When removing the luggage compartment lid, tension must first be removed from the torsion rods which support the lid. This can be done by prising out the hinge hook with a suitable tool, see Fig. 3.

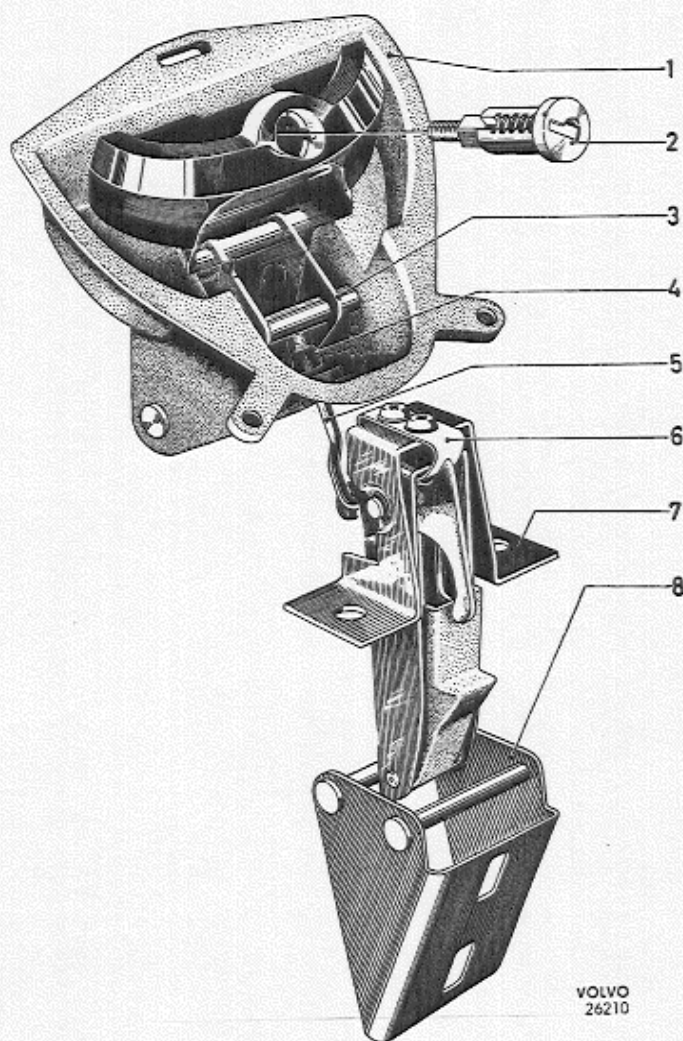
The locking device on cars with chassis numbers lower than 21000 are attached to the body under the luggage compartment lid by means of two bolts and a locking ring. The locking device is released by pressing in the press button. The locking loop on the lower edge of the luggage compartment lid is adjusted to permit variation in tension when closing.

When removing the lock, the two bolts on the edge of the body opening and the locking ring round the lock press button are removed, see Fig. 4. When fitting, the locking ring is first placed on and after this, the bolts. When fitting, make sure that the rubber seal round the locking button fits properly.

The locking device on cars with effect from chassis number 21000 is attached to the luggage compartment lid with bolts. The locking piece is attached to the body with two bolts. Adjusting the lock is done by screwing the link (5, Fig. 5) up or down. The lock cylinder (2, Fig. 5) is attached to the handle with a nut. The locking piece has oval holes to permit adjustment.

Doors

Removing the front door

1. Remove the door check, see Fig. 6. The attaching bolts for this are accessible after the side insulation material on the body has been removed. The door check can also be removed from the door by unscrewing the guide roller and hooking off. In order to get at the guide roller, the door upholstery must be removed, see under "Removing the door handle and upholstery".
2. Unscrew the four countersunk screws which hold the doors to the upper and lower hinge. The door sealing strip must be moved in order to get at the hinge screws. This is done by releasing the two plates over the hinges to which the strip is glued, and carefully pulling to one side, see Fig. 7. When doing this, make sure that the rubber strip does not come away from the plate or door. Fitting the door is done in the reverse order

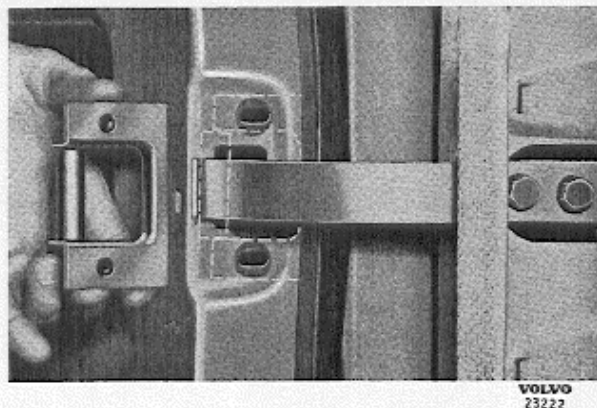

Fig. 6. Door check.

to removing. Since the holes in the door are larger than the diameter of the bolts, and that the nut plates are moveable, the hinge attachment can be adjusted both vertically and laterally. The door is adjusted longitudinally at the hinge attachment in the body.

Removing the rear door

(see also under "Removing the front door")

1. Remove the door check. The attaching bolt for this is accessible after the rubber plug in the centre pillar has been removed.
2. Remove the plates over the hinges. Remove in the centre pillar has been removed. The holes in the centre pillar are larger than the diameter of the bolts. When running nuts are used, this enables the door to be adjusted vertically and laterally.

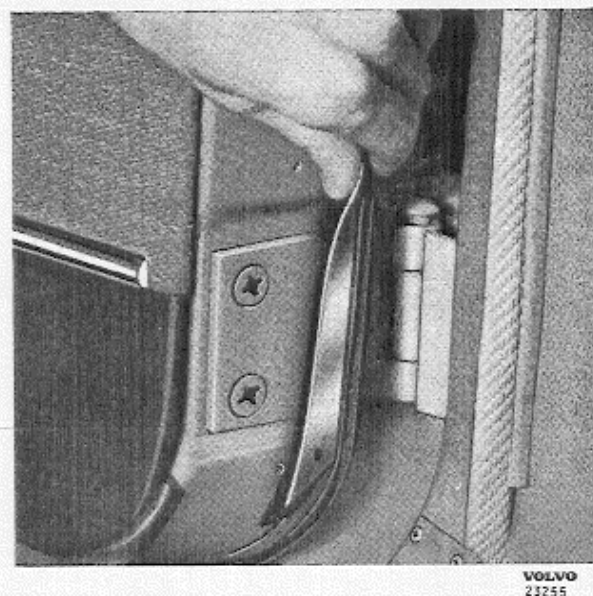

Fig. 7. Plate over hinge.

Removing the door handle and upholstery

1. Remove the armrest. This is attached with two screws which are accessible from underneath the armrest, see Fig. 8.
2. Remove door handle and winding handle. This is done by prising out the blocking washer which holds them with tool SVO 2297, see Fig. 9. The window winder, locking washer and ring are illustrated in Fig. 10.

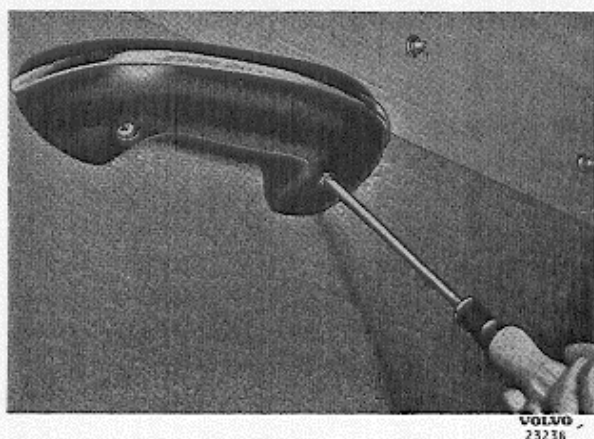
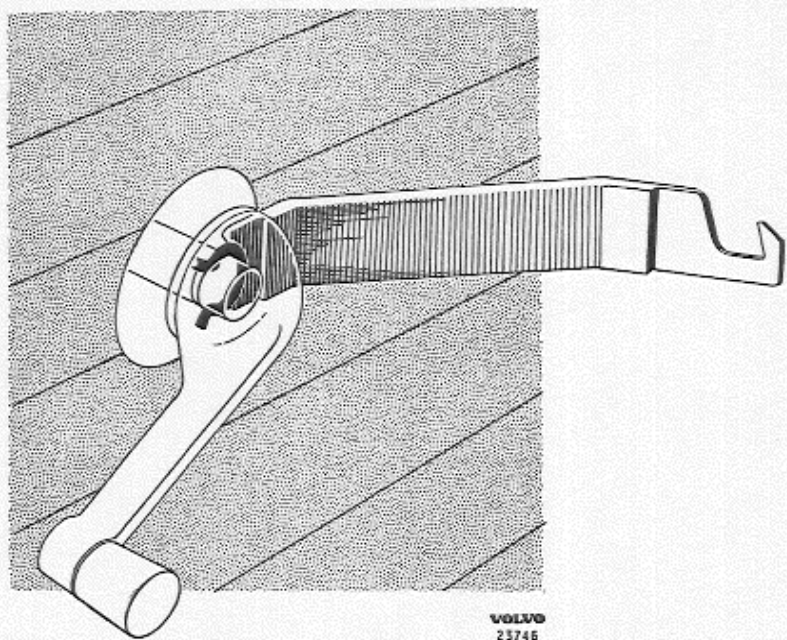
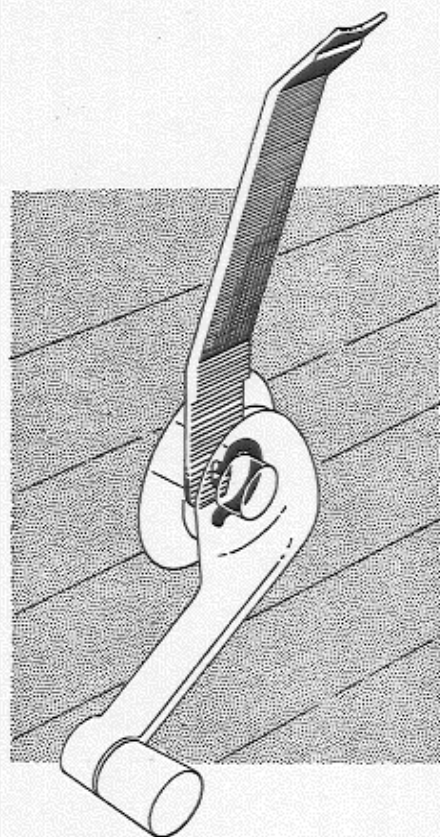
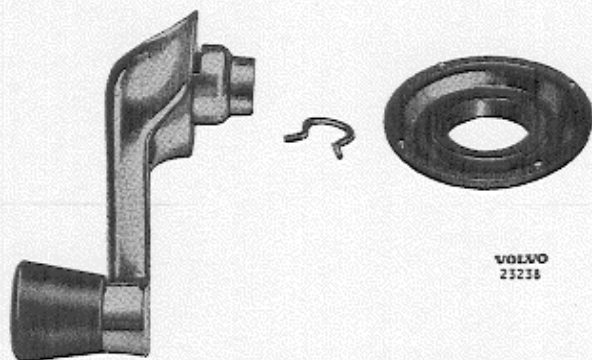

Fig. 8. Removing the armrest.



VOLVO
23746

Fig. 9. Removing and fitting the winding handles.



VOLVO
23238

Fig. 10. Winding handle with locking ring.

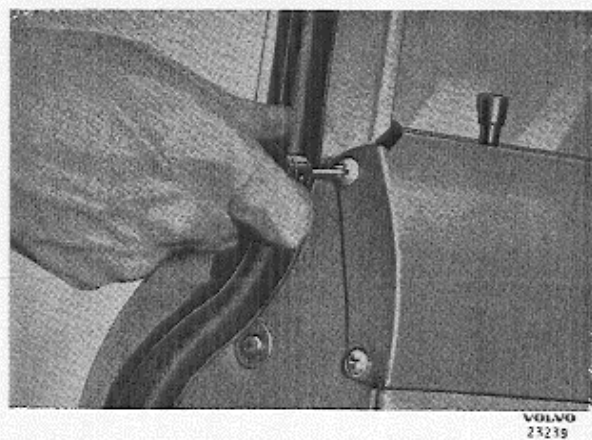

VOLVO
23239

Fig. 11. Removing the upper trim moulding.

3. Remove the upper trim moulding. This is attached to the door edges by four screws, see Fig. 11.
4. Remove the door upholstery by carefully applying a screwdriver or similar under the padded edge and then bending outwards, when the upholstery will come away, see Fig. 12.
5. Remove the paper protectors which are fitted over the holes in the inner plate of the door.

Removing the door lock and lock handle

Carry out operations 1—5 under "Removing the door upholstery".

1. Unscrew the two screws which hold the guide rail for the window. The screws are accessible from the edge of the door as shown in Fig. 13. Lift out the guide rail.
2. Unscrew the three screws which hold the inner handle mechanism (remote control).
3. Lift off the link arm between the lock button and roller mechanism and disconnect the link for the outer handle from the roller mechanism.
4. Unscrew the four screws on the edge of the door which hold the toothed roller mechanism.
5. Lift off the door lock with remote control.
6. The door handle is removed by unscrewing the two screws which hold it, see Fig. 14. The screws are accessible from the inside of the door and are most easily removed after the window has been let down or removed. For this, see under "Removing the window".

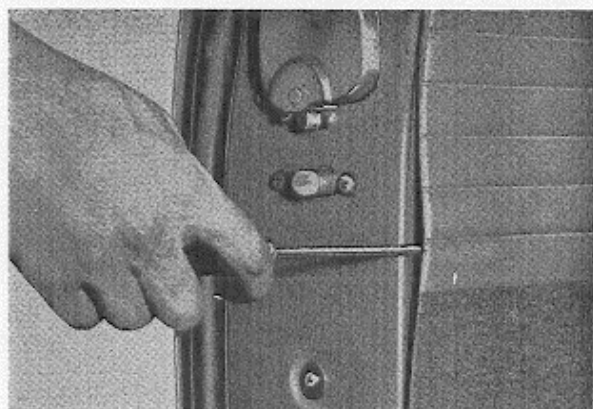

Fig. 12. Removing the door upholstery.

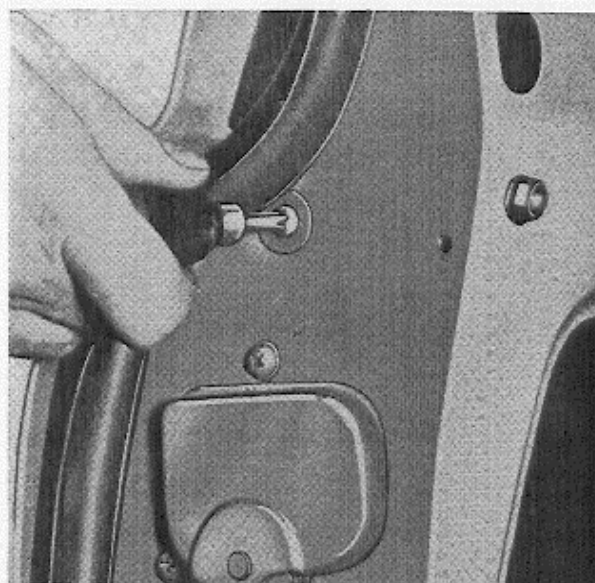

Fig. 13. Unscrewing the upper screw for the guide rail.

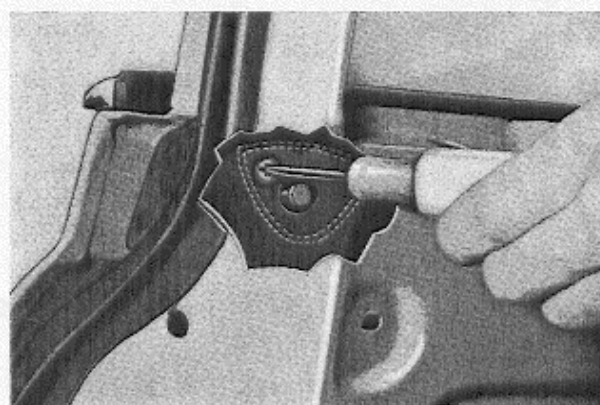

Fig. 14. Removing the lock handle.

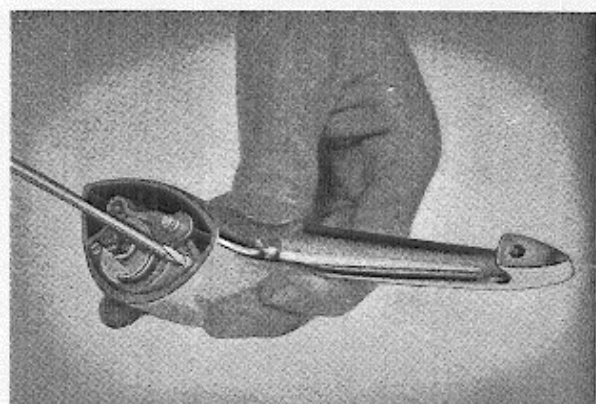

Fig. 15. Dismantling the lock handle.

Dismantling the door handle

1. Unscrew the two screws which hold the press button and lock plunger to the door handle, see Fig. 15.
2. Press out the lock peg as shown in Fig. 16.
3. Turn the key backwards and forwards a few times in the press button at the same time as pulling outwards, when the lock plunger will release and can be pulled out as shown in Fig. 17.



VOLVO
23243

Fig. 16. Pressing out the lock peg.

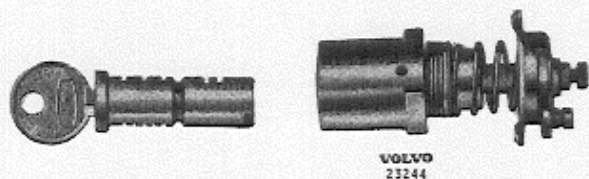
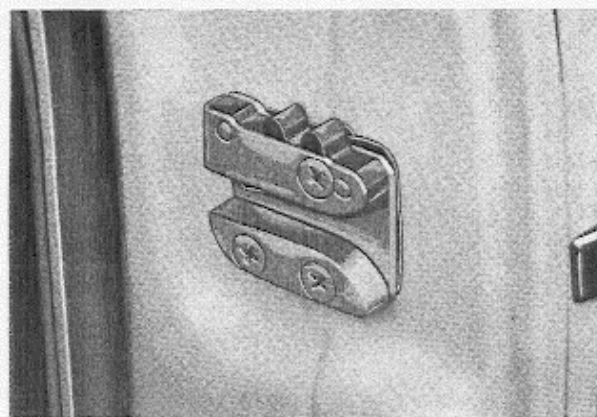

Fig. 17. Press button dismantled.

Striker block

The striker block is made of steel and fitted with a moveable nut plate. The block can be adjusted since the holes in the body are larger



VOLVO
22026

Fig. 18. Striker block.

than the diameter of the attaching screws, see Fig. 18.

The vertical position of the striker block can be checked by closing the door with the outer handle press button pressed in, when the guide pin should slide right into the striker block. Note. This should be done immediately after the striker block has been fitted.

Window winder and window

Removing and fitting

Carry out operations 1—4 under "Removing the door upholstery".

Carry out operations 1—5 under "Removing and fitting the ventilation window".

1. Remove the keeper which holds the carrier on the winding cable to the winding rail under the window and lift this up, see Fig. 19. There is no carrier on the rear doors and the keeper lies directly against the winding chain.
2. Release the cable tensioning device by un-

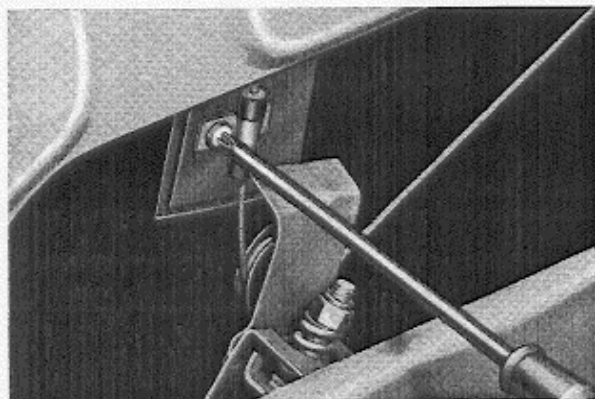

VOLVO
23246

Fig. 19. Removing the carrier keeper.

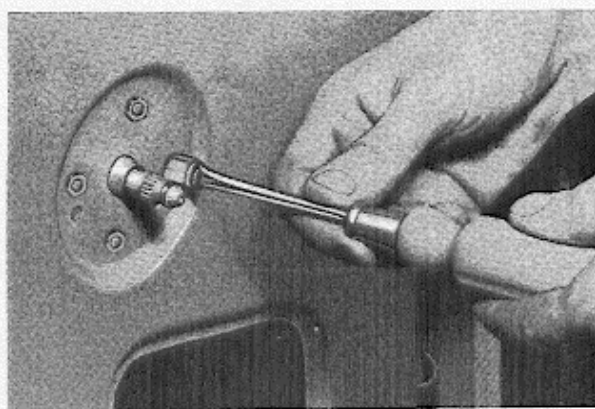

VOLVO
23245

Fig. 20. Removing the winding roller.

screwing the nut on the tensioning screw at the lower jockey pulley. Lift off the cable and chain.

3. If necessary, the upper jockey pulley, lower jockey pulley with tensioning device and the winding roller itself can be removed. The winding roller is removed by unscrewing the four screws, see Fig. 20, after which the roller and shaft are lifted out. Before fitting the window, make sure that the guide strips and sealing strips are in good condition. If these are worn or damaged, they must be replaced.

The cable for the winding mechanism should be properly stretched but not too tightly. Lubricate the cable and chain with grease, and the jockey and pulley and winding roller with oil.

After fitting, check that the window runs easily in the guide rails.

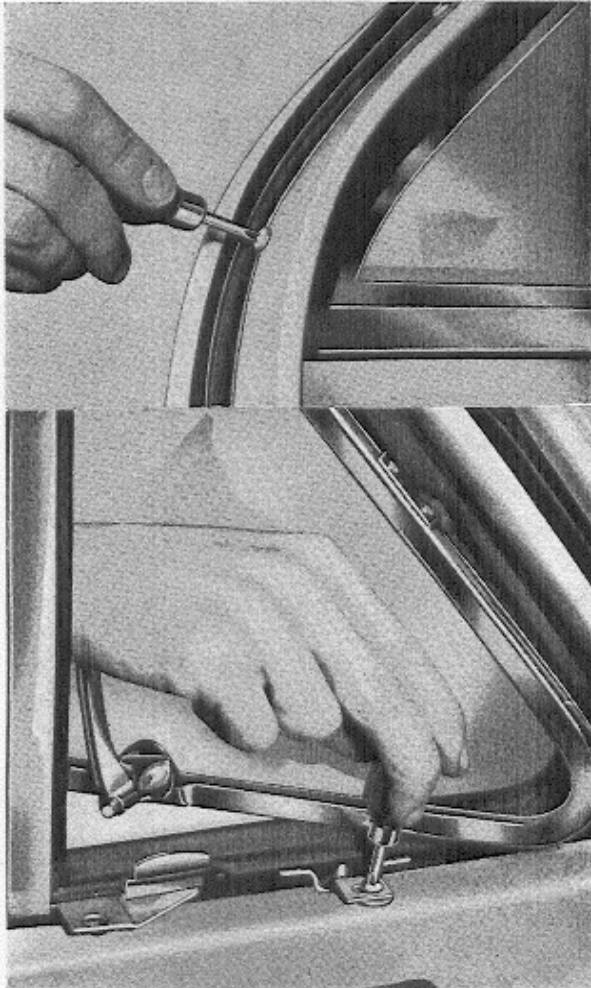

Fig. 21. Removing the ventilation window.

Ventilation window Removing and fitting

The ventilation window also forms one of the guide rails for the winding window. When removing the ventilation window with strips, the following procedure is advisable.

1. Carry out operations 1—5 under "Removing the door upholstery".
2. Unscrew the five screws which hold the window to the door and door arch, see Fig. 21.
3. Unscrew the screw which holds the guide rail to the window, see Fig. 22. This only applies to the extended guide rail on the front doors.
4. Remove the upper guide strip with a screwdriver, see Fig. 23.
5. Lift up the window as shown in Fig. 24.

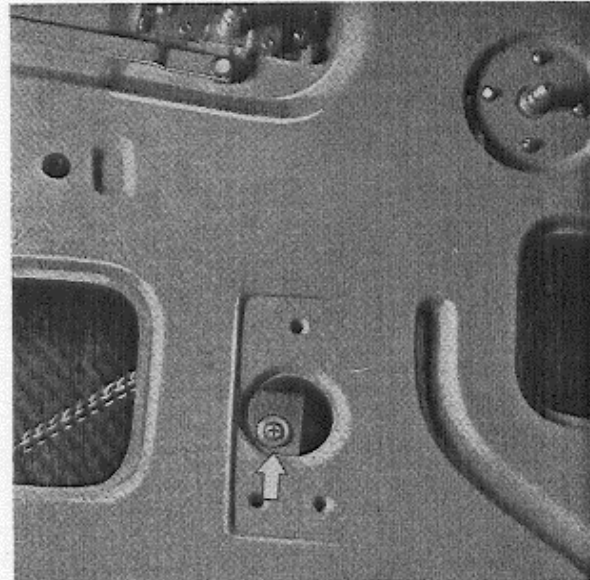

Fig. 22. Attaching screw for window guide rail.

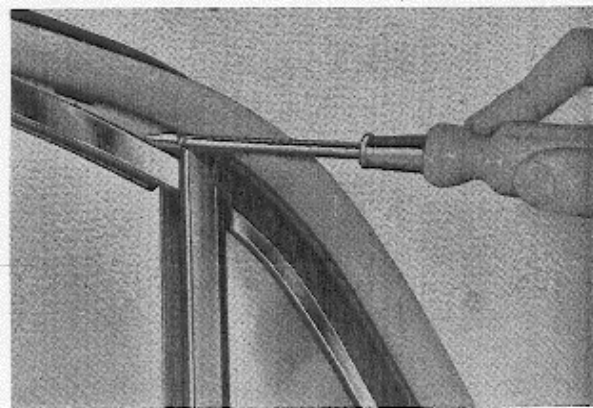

Fig. 23. Removing the upper guide strip.

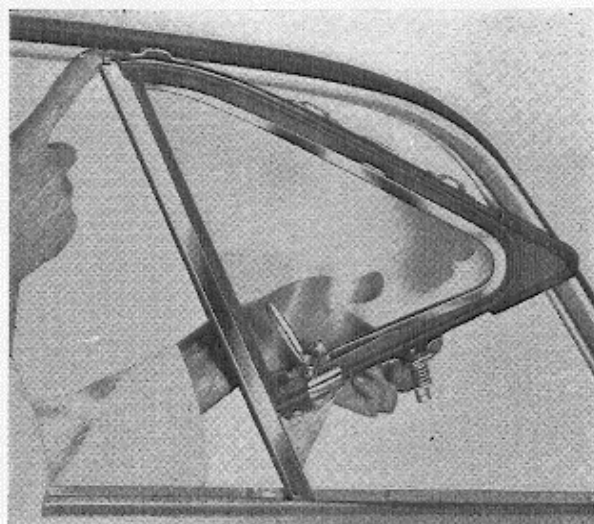

Fig. 24. Lifting up the ventilation window.

Fitting and adjusting the lock Front door (2- and 4-door models)

1. Fit the lock (10, Fig. 25) with the remote control (12) into the door without tightening the screws.
2. Adjust the measurement A (fig. a, Fig. 27) to 15 ± 0.5 mm (0.59 ± 0.02 ") by turning the lock. Tighten the lock hard. If turning the lock is not sufficient to obtain the correct measurement for A , the lock must then be screwed up as near to A as possible and the remaining adjustment done by bending the lever (5). The measurement A must be kept within the given tolerances.
3. The remote control (12) with split pin (11) inserted is moved backwards so that the

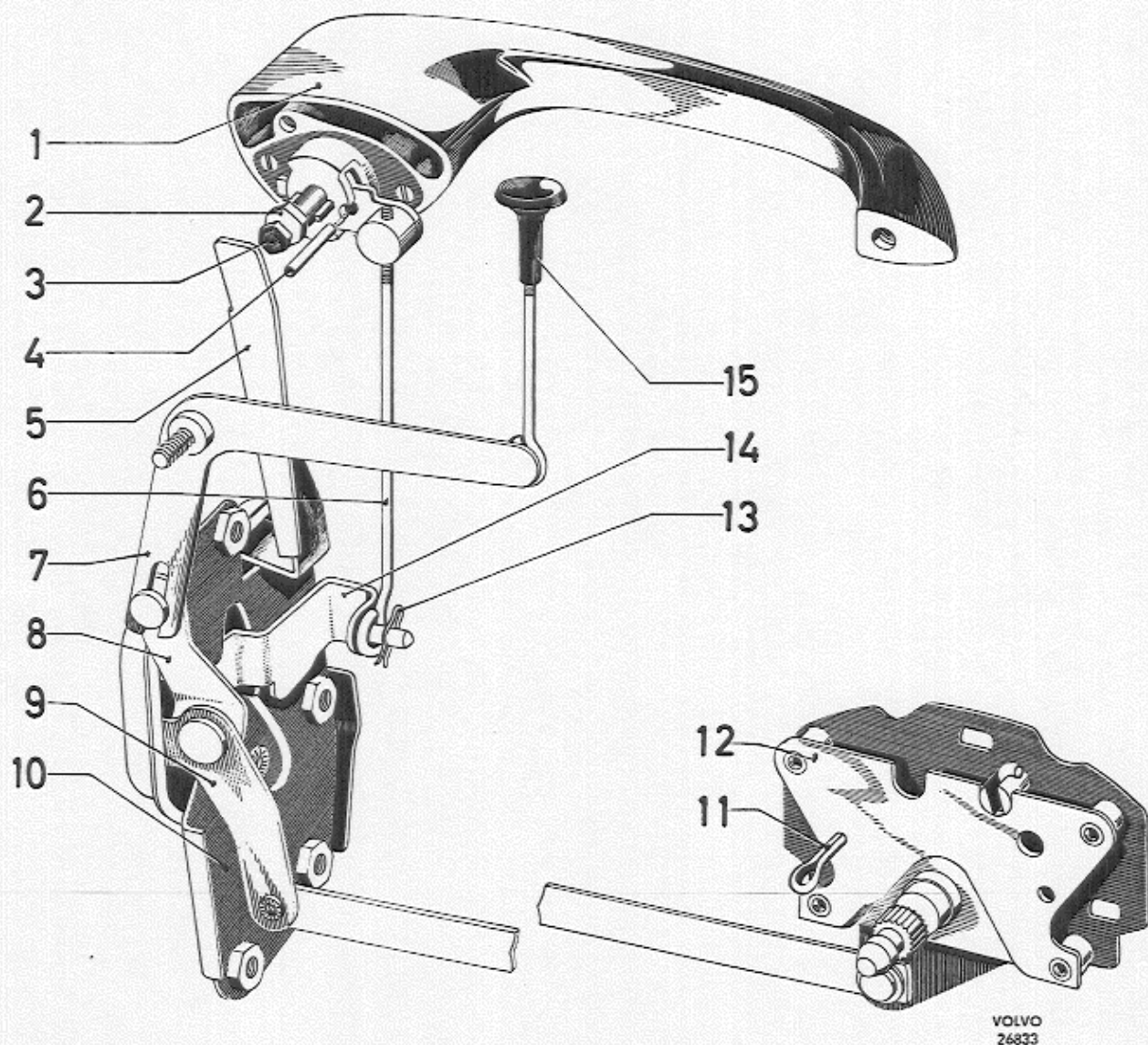

Fig. 25. Adjusting the lock, front door.

lever (9) stops against the lock (10). The remote control is screwed on in this position. Remove the split pin (11).

4. Fit the link (7) for the inner lock button (15).

Rear door

1. Fit the lock (11, Fig. 26) with remote control (13) in the door without tightening the screws.
2. Adjust the measurement A (fig. a, Fig. 27) to $17 \pm 0.5 \text{ mm}$ ($0.67 \pm 0.02''$) by turning the lock. Tighten the lock hard. If turning the

lock is not sufficient to obtain the correct measurement for A, the lock must be screwed on as near as possible to A and the remaining adjustment done by bending the lever (5). The measurement A must be kept within the tolerance mentioned.

3. The remote control (13) with split pin (12) inserted is moved backwards so that the lever (10) stops against the lock (11). The remote control is screwed on in this position. Remove the split pin (12).
4. Fit the lever (17) and connect the link (16) to the lever (7).

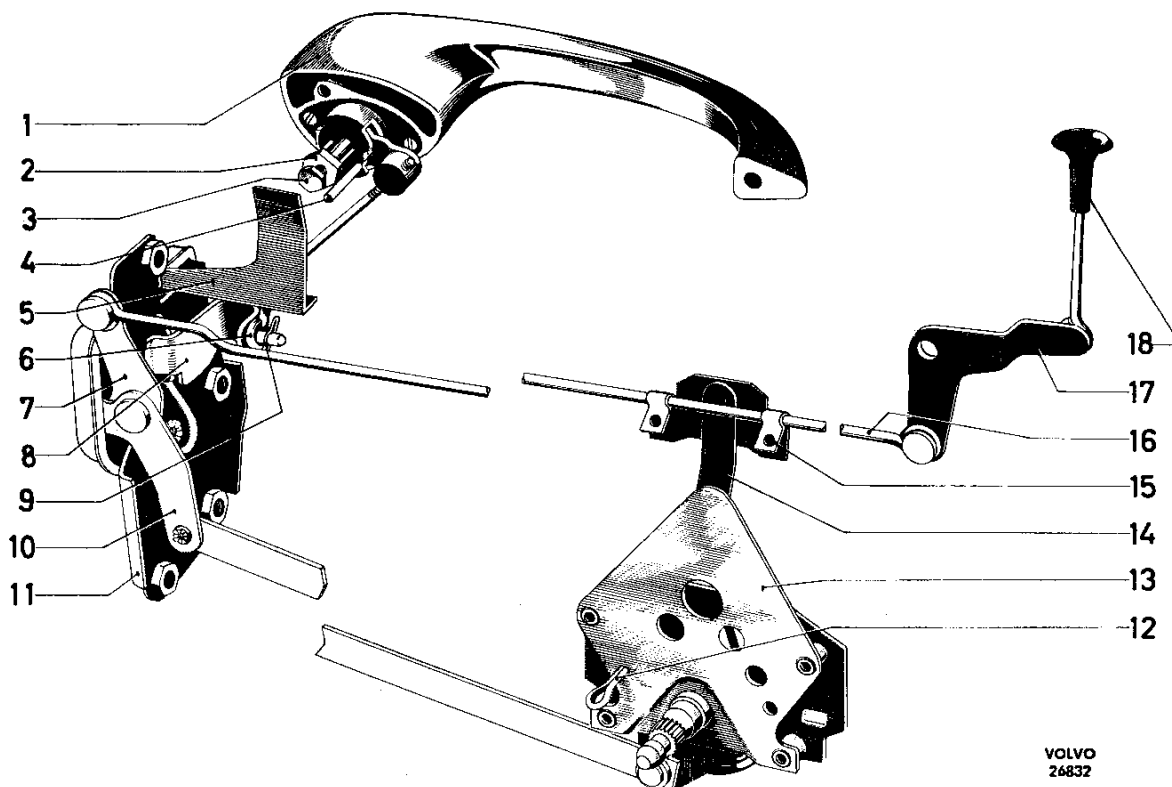

Fig. 26. Adjusting the lock, rear door.

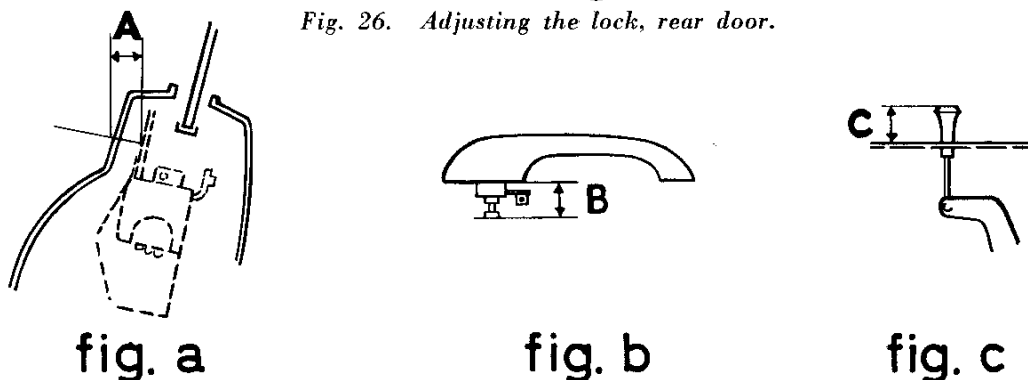

Fig. 27. Adjusting measurements for the lock.

5. Set the lever (7) to the lock position, that is to say, rearwards towards the lock, and the catch rod (16) in the rear catch position. Check through the inspection hole (12) that the catch rod goes fully into the catch position. In this position the lever (14) is secured to the rod (16) by means of the screws at (15). Check that the rod (16) does not rub against the inner plate of the door. It must not be bent out so much that it touches the inner trim moulding when this is screwed on.

Fitting and adjusting the outer door handle

Front door (2- and 4-door models)

Early production

1. Check that the measurement B (fig. b, Fig. 27) = 15 ± 1 mm (0.59 ± 0.04 "). Adjust if necessary. Tighten the locknut (2) on the bolt (3, Fig. 25).
2. Fit the outer handle (1) with link (6).
3. Connect the link (6) to the lever (14). When doing this, one of the three holes in the link must be selected so that the recess and hole in the outer handle coincide. This can be checked by inserting the pin (4) into the hole in the outer handle as shown in the figure. The pin should go right in when the press button (15) is depressed, that is to say, the lever (7) is depressed and the lever (8) moved back against the lock.

Late production

1. Check that the measurement B (fig. b, Fig. 27) = 15 ± 1 mm (0.59 ± 0.04 "). Adjust if necessary. Tighten the locknut (2) on the bolt (3), Fig. 25.
2. Fit the outer handle (1) with link (6).
3. Connect the link (6) to the lever (14). The lever in the handle must be adjusted in such a position that a pin (4) (3 mm = 0.12") can be inserted into the hole in the handle. Adjustment is carried out by screwing the link up or down so that the eye (6) of the link coincides with the lever (14) on the lock.

Rear door

Late production

1. Check that the measurement B (fig. b, Fig. 27) = 15 ± 1 mm (0.59 ± 0.04 "). Adjust if necessary. Tighten the locknut (2) on the bolt (3), Fig. 26.
2. Fit the outer handle (1) with link (6).
3. Connect the link (6) to the lever (8). The lever in the handle should be adjusted to such a position that a pin (4) (3 mm = 0.12") can be inserted into the hole in the handle. Adjusting is carried out by screwing the link up or down so that the eye (6) coincides with the lever (8) on the lock.

Inner locking button

Measurement C (fig. c, Fig. 27) when in the pressed down position should be 12 ± 1 mm (0.47 ± 0.04 ") for both the front and rear door.

Sealing strips

A Glued strips

When fitting new rubber strips, the following procedure is recommended:

1. Remove the old strips.
2. All traces of old adhesive should be removed carefully from the metal surfaces with cellulose thinner, petrol or similar. It is most important to carry out this carefully since no residue from the old adhesive must be left on the metal, but at the same time care must be taken to make sure that the paintwork is not damaged by the solvent used. (Requirements: clean rags, plastic wood).
3. The new rubber strips should be thoroughly cleaned with petrol, methylated spirits or similar. (Requirements: clean rags, fibre brush).
4. After they have dried, the rubber strips should be coated with Dekalin TH and then allowed to dry to a non-tacky state before being placed on, that is to say, normally for at least 15 minutes. (Requirements: thick hair brush).
5. The metal surfaces to which the rubber strips are to be attached are then coated with Dekalin TH. (Requirements: thick hair brush).

6. The treated and non-tacky rubber strips are then pressed onto the newly-coated adhesive on the metal.
7. The rubber strips should be pressed firmly against the metal surfaces so that there is no air trapped in the joints.

NOTE. The door must not be closed for 15 minutes after the strip has been applied.

B Strips attached with rail

On late production cars the sealing strip is attached by means of a rail which is spot-welded to the door.

The sealing strip is removed by pulling it outwards, when the projection of the strip releases from the rail.

When fitting the sealing strip, one of the projections is placed in position in the rail after which the other projection is pressed down into the rail with the help of a screwdriver. The tool is moved along the rail as shown in Fig. 28.

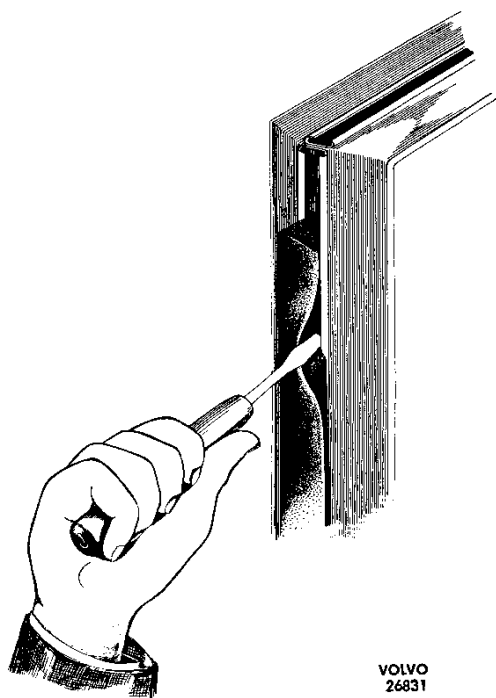

Fig. 28. Fitting sealing strip for the door.

Windscreen and rear window

Removing

1. Remove the trim moulding with the help of a wooden putty knife and lift off the strip as shown in Fig. 29.

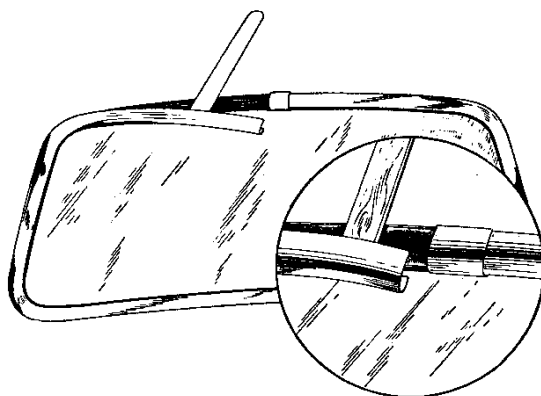

Fig. 29. Removing the trim moulding.

2. Remove the rubber strip adhesive and glass with the help of a putty knife, see Fig. 30.
3. Grasp the rubber strip as shown in Fig. 31 and pull it off.
4. Lift out the glass.

All parts which are to be re-fitted to the car should then be thoroughly cleaned in white spirit.

Fitting

1. Check that the windscreen opening is not distorted by holding a windscreen pressed against the opening. The glass should lie firmly against the metal all the way round. If there is any unevenness or distortion, the edge must be adjusted.
2. Place the glass on a blanket or similar and fit the rubber strip round the glass.
3. Press a leather strap or strong cord in the groove in the strip as shown in Fig. 32. Place the glass in position and press it against the edge of the metal, and then pull the cord from inside the car so that the

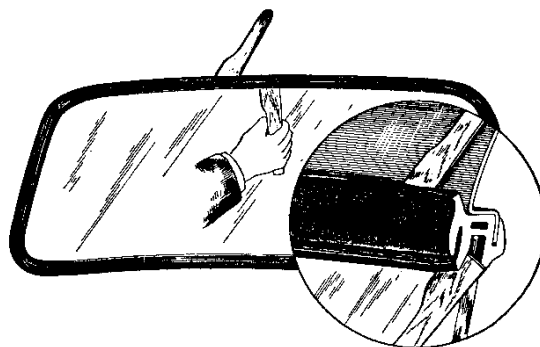

Fig. 30. Removing the rubber strip.

rubber strip "creeps" over the edge of the metal. Placing in the cord is facilitated by using a narrow pipe to open the groove in the strip so that the cord can run through the pipe at the same time, as shown in Fig. 33.

4. The groove in the rubber strip is sealed with putty. The putty applicator is moved as shown in Fig. 34. A compressed-air applicator should be used partly so that the putty goes sufficiently deep in the groove, and partly so that even filling is obtained. The applicator should be moved round at the angle shown in Fig. 34.

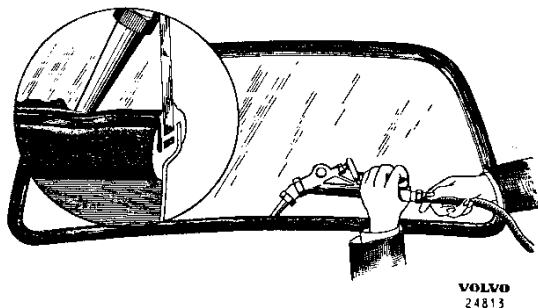

Fig. 34. Puttying the glass.

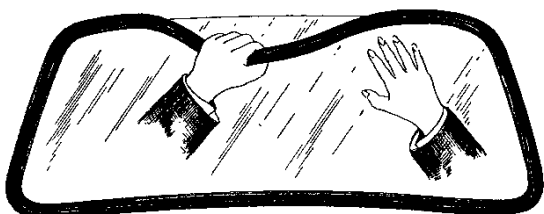

Fig. 31. Removing the glass.

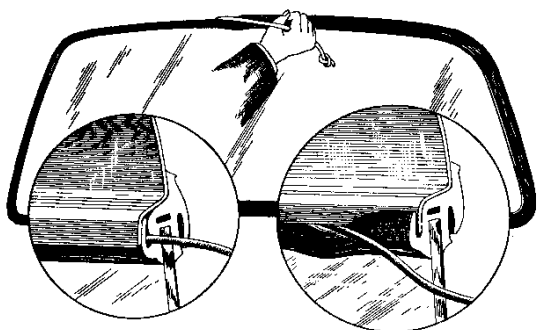

Fig. 32. Fitting the sealing strip.

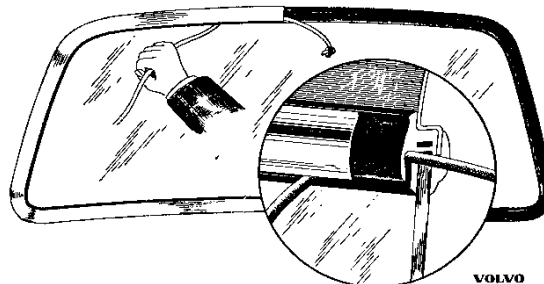

Fig. 35. Fitting the trim moulding.

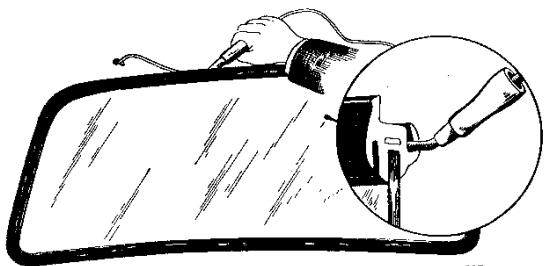

Fig. 33. Placing in the leather thong.

Fitting the trim mouldings

1. Place a thong or cord in the groove of the rubber strip in the same way as when fitting the glass, see Fig. 35. It is assumed that the glass is fitted in the body.
2. The projection of the trim moulding is then pressed down into the groove of the rubber strip, after which the leather thong is pulled out. The edge of the rubber strip will then "creep" up over the sealing strip, see Fig. 35.
3. The joining pieces of the trim mouldings are slid along the moulding and should be placed on one of the mouldings before beginning fitting, after which the joining piece is slid over the joint when the mouldings are in place.

Upper trim moulding for door, four-door model

The upper trim moulding of the door is attached by means of spring clips.

On late production cars the trim moulding is provided with a rubber scraping strip. This is directly interchangeable with the earlier type of moulding.

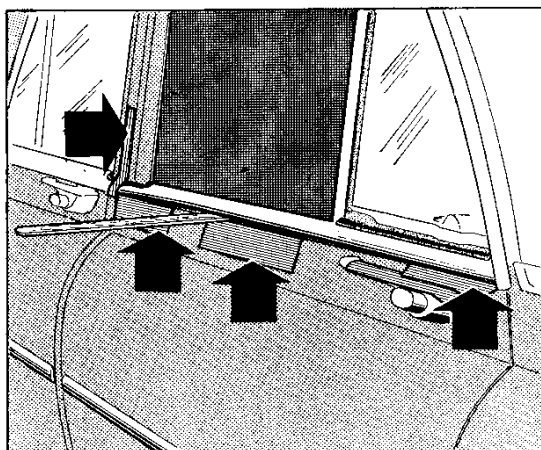

VOLVO
23741

Fig. 36. Placing the protecting tape.

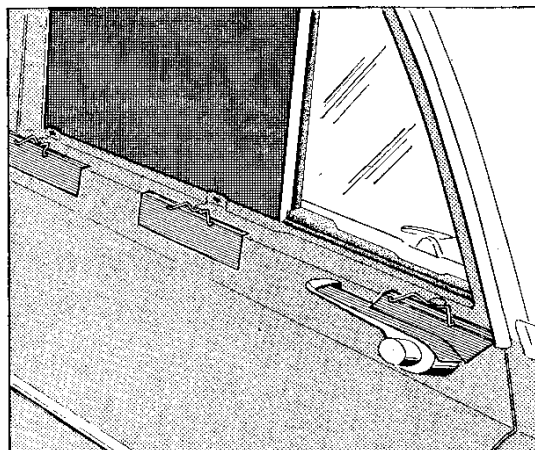

VOLVO
23743

Fig. 38. Placing spring clips.

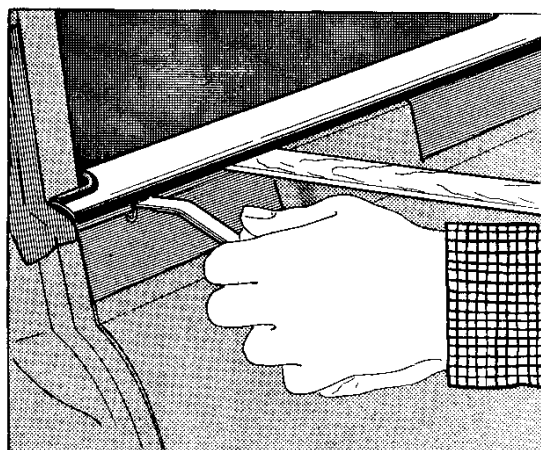

VOLVO
23742

Fig. 37. Removing spring clip.

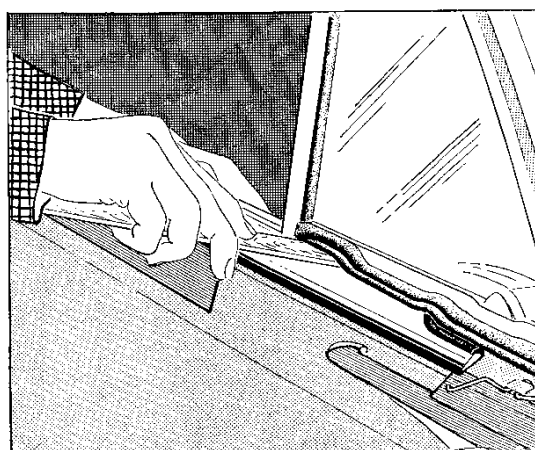

VOLVO
23744

Fig. 39. Fitting the moulding.

When removing and fitting the moulding, the following procedure should be adopted, otherwise the paintwork can easily be damaged.

1. Lift the trim moulding out slightly with the help of a piece of wood and place tape (for example, Mystic tape) on the door and door pillar as shown in Fig. 36.
2. Lift the strip with the piece of wood so that the spring clip can be unhooked. See Fig. 37. Tool SVO 2297 can be used for this.
3. If necessary, new spring clips can be placed in as shown in Fig. 38.
4. The moulding is fitted by sliding it forward under the sealing rubber for the ventilation window, see Fig. 39. In order to facilitate this, the rubber under the ventilation window should be lubricated with vaseline.

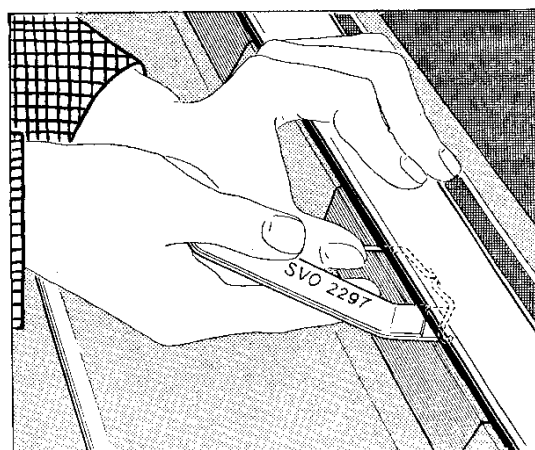

VOLVO
23745

Fig. 40. Fitting spring clip.

- The spring clips are fitted with the help of tool SVO 2297, see Fig. 40. When fitting, make sure that the tool does not cut through the tape, otherwise the paintwork will be damaged.

Removing the rear ventilation window

2-door model

Unscrew the two safety belt anchoring bolts, remove the entry handle and lift off the cover plate, after which the hinge screws for the ventilation window are accessible, see Fig. 41.

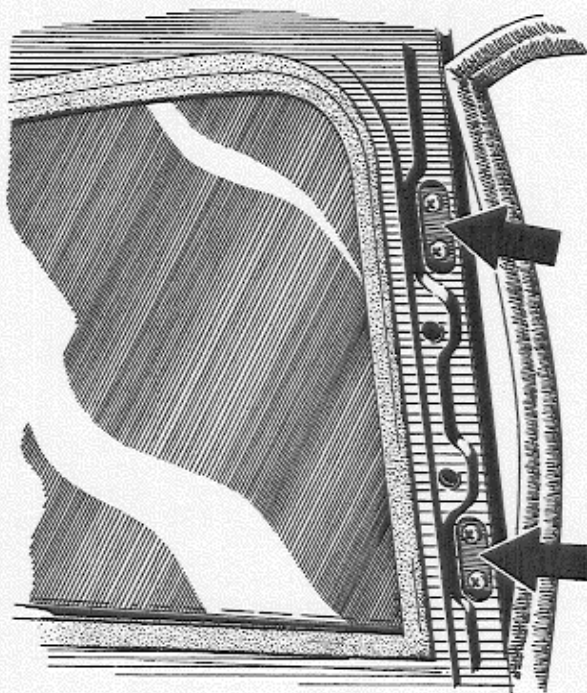

VOLVO
26227

Fig. 41. Removing the rear ventilation window.

Instrument panel

Removing the instrument panel

The instrument panel is attached to the body with screws. These are accessible partly after the front doors have been opened and partly after the inner trim moulding for the windscreen has been removed, see Fig. 42.

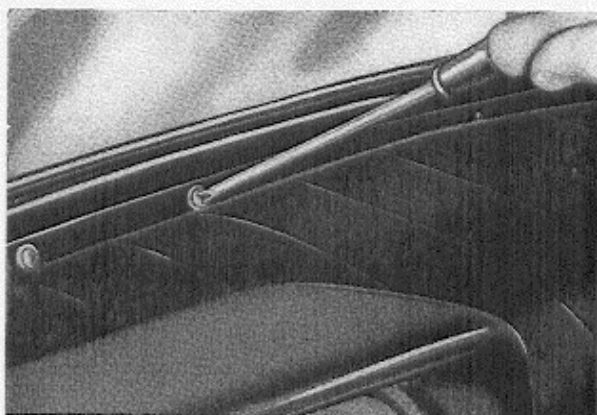

VOLVO
23251

Fig. 42. Removing the instrument panel.

Interior fittings and upholstery

Front seat

The front seat is built up on a pressed steel frame and the backrest on a tubular frame. The springs in the seat consist of coiled upholstery springs and those in the backrest of No-Sag flexing springs. On early production cars, the filling consists of woven jute, fibre matting and padding, and on late production the filling consists of coconut latex and foam plastic.

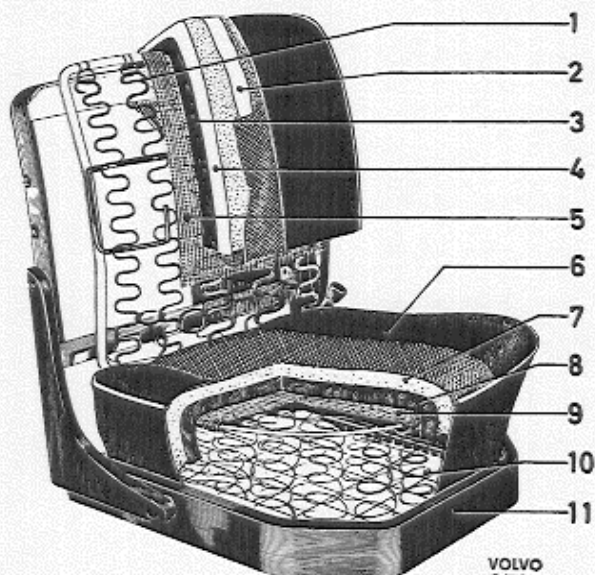

VOLVO
26709

Fig. 43. Front seat, late production.

- | | |
|------------------------|------------------|
| 1. Flexing springs | 7. Foam plastic |
| 2. Calico | 8. Fibre fabric |
| 3. Fibre fabric | 9. Jute fabric |
| 4. Foam plastic | 10. Coil springs |
| 5. Jute fabric | 11. Frame |
| 6. Upholstery covering | |

Rear seat

The rear seat and backrest are built up in the same way as the front seats except that the framework consists of a wooden frame.

Door upholstery

The door upholstery consists of wood-fibre panels lined with padding and upholstery material. It is attached to the door with clips. The front armrests are made of moulded plastic and secured to the inner plate of the door with screws.

Headlining

The headlining consists of fabric stretched on the roof ribs and attached with fabric retainers fitted on the upper limit of the body sides.

Bulkhead and floor

The sides of the bulkhead are lined with insulating material which is secured with clips. The bulkhead itself is covered with felt and galon fabric. The floor is covered with rubber mats.

Combination instrument

The combination instrument consists of the speedometer, temperature gauge, fuel gauge, four control lamps and two instrument lighting lamps. The combination instrument is attached to the instrument panel with two screws. The combination instrument is shown in Figs. 44 and 45. Before working on the instruments under the instrument panel, one of the battery leads should be disconnected from the battery.

The combination instrument is removed by first taking out the control lamps and instrument lighting. The speedometer cable is then removed

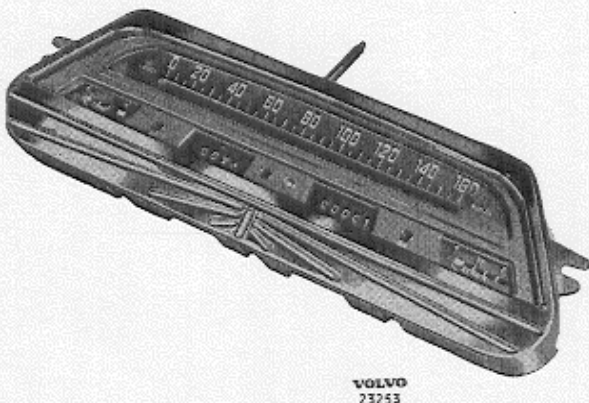

Fig. 44. Combination instrument, front side.

together with the measuring unit of the temperature gauge and the leads to the fuel gauge. Then remove the nuts.

When replacing an individual instrument, see under the heading for the instrument concerned.

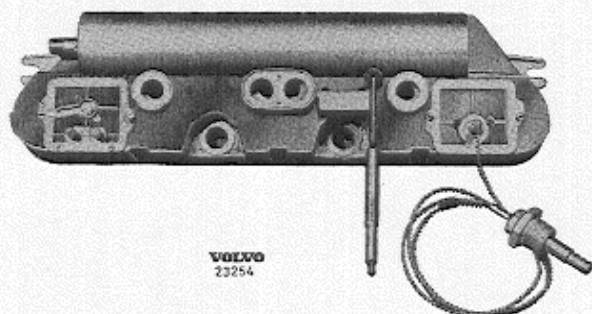

Fig. 45. Combination instrument, rear side.

Removing the temperature and fuel gauges

The temperature and fuel gauge instruments are screwed onto the rear side of the combination instrument. Replacing is done as follows.

Fuel gauge

1. Disconnect one of the battery leads.
2. Disconnect the leads to the fuel gauge and mark these.
3. Unscrew the four screws which hold the fuel gauge to the combination instrument.
4. Lift out the instrument carefully and avoid bending the pointer hand.

Fitting is done in the reverse order. When fitting, make sure that the instrument is connected correctly. If the leads are changed over, this will ruin the instrument.

Temperature gauge

1. Disconnect one of the battery leads.
2. Drain off enough coolant so that the measuring unit of the instrument comes above the coolant level.
3. Disconnect the measuring unit on the instrument in the cylinder block.
4. Unscrew the screws which hold the instrument to the instrument panel and lift this off.
5. Remove the rubber bushing in the bulkhead and pull the measuring unit through the panel. Avoid bending the measuring pipe sharply.

Fitting is done in the reverse order.

Replacing the fuel gauge tank fitting

1. Make sure that the ignition key is in the neutral position.
2. Blow thoroughly clean round the tank fitting.
3. Disconnect the lead and screws which hold the tank fitting and lift this out.

Fitting is done in the reverse order. Always use a new gasket as this will prevent leakage and the smell of petrol in the car.

Radiator

Removing and fitting

1. Drain out the coolant. If anti-freeze solution is used, collect this up in a clean vessel.
2. Disconnect the hose clips at the upper and lower radiator hoses.
3. Remove the bolts on either side and the bolt under the radiator.
4. Lift up the radiator carefully and avoid damaging the honeycomb system.

The radiator is fitted in the reverse order. When fitting, make sure that the radiator hoses and hose clips are in good order.

Heater

Early production

The heater, which is illustrated in Fig. 46, consists of: air intake with fan motor, honeycomb system, distributing housing with shutter and thermostat.

The air intake and fan motor are removed as follows:

1. Disconnect the lead to the fan motor.
2. Remove the bar between the body and air intake.
3. Unscrew the three screws under the rubber gasket for the bonnet and lift off the air intake with fan motor.

The fan motor is removed from the air intake by unscrewing the two remaining screws on the side, after which the motor can be pulled out.

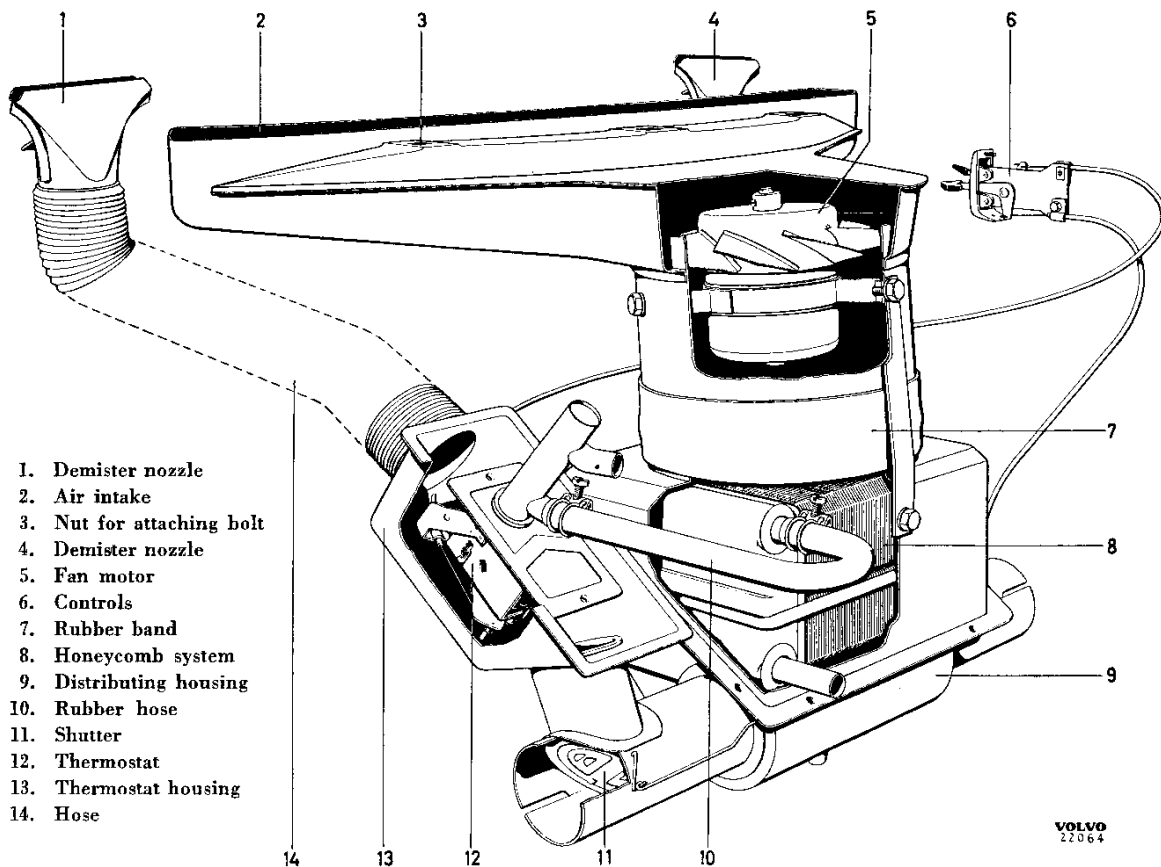

Fig. 46. Heater, early production.

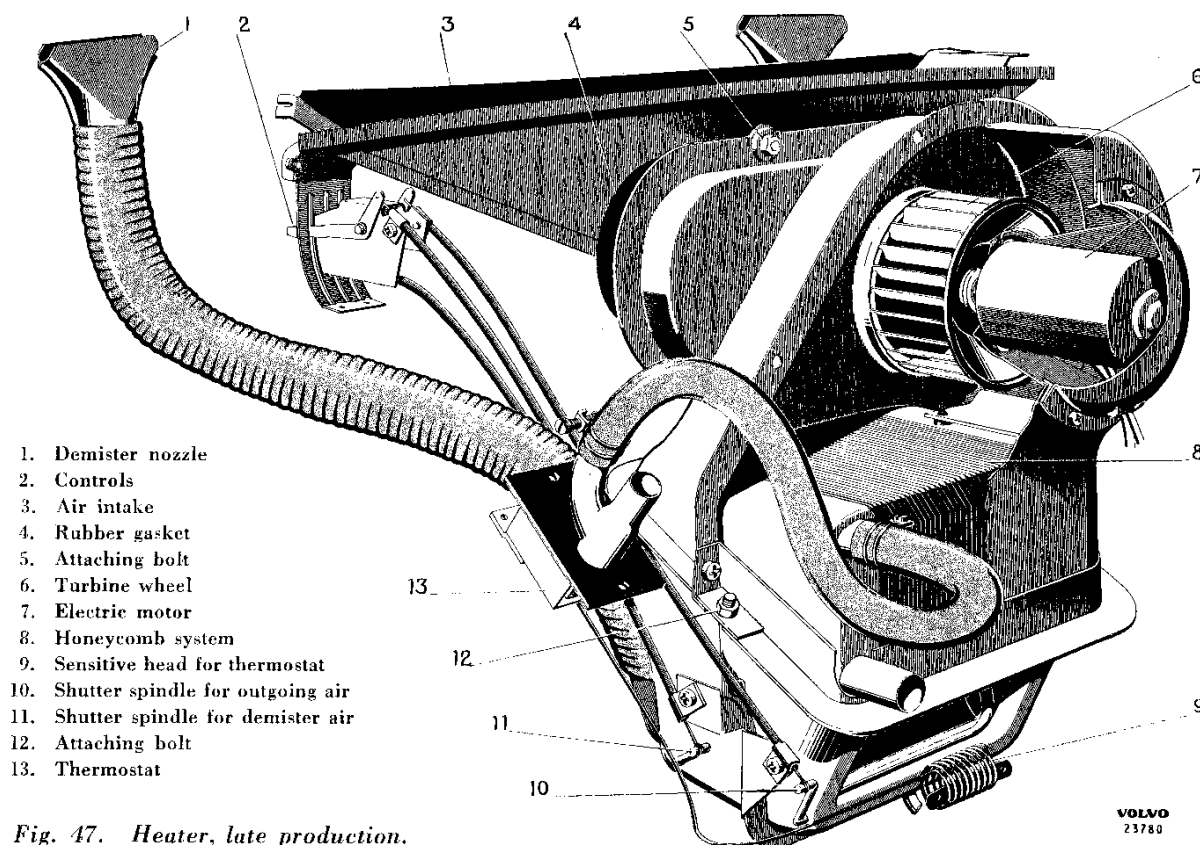

Fig. 47. Heater, late production.

The fan motor is provided with self-lubricating bushings. Lubricating need only be carried out in connection with reconditioning the fan motor.

When fitting, ensure that the fan motor is centred properly and that the earth lead makes good contact.

The honeycomb system can be removed after the distributing housing has been taken off. This is bolted on from inside the car. When removing, the coolant must first be drained off. The hoses on the honeycomb system are then disconnected. The distributing housing can then be unscrewed and the honeycomb system removed. When doing this, hold up the ends of the pipes high so as to prevent water from running out inside the car.

Fitting is done in the reverse order. When fitting, make sure that the hoses and hose clips are undamaged. Damaged parts must be replaced.

The thermostat can be removed after its casing has been taken off. When removing, first drain off enough coolant so that the thermostat comes above the coolant level.

Late production

The heater illustrated in Fig. 47 consists of: air intake (welded to the body), water deflector, turbine housing with fan motor and turbine, honeycomb system, distributing housing with shutter, thermostat and controls.

The heater is removed and fitted as a complete unit as follows.

1. Drain off the coolant.
2. Disconnect the lead to the fan motor.
3. Disconnect the water hoses, demister hoses and cables.
4. Unscrew the three bolts which hold the heater to the body (5 and 12, Fig. 47) and lift it off.

The fan motor is provided with self-lubricating bushings. Lubricating need only be done in connection with reconditioning the fan motor.

The honeycomb system can be removed after both the casing halves have been taken apart. The spiral (9, Fig. 47), forms the sensitive head of the thermostat and is placed in front of the control opening for the outgoing air.

Checking the body

The most important body and chassis dimensions are shown on illustrations X and XI. The measurements are intended for checking and facilitating repair work in the event of damage. The body and chassis are drawn in a system of squares, where all the measurements start from O co-ordinates (the lines marked with O in the system of squares). The measurements can be localized both longitudinally, vertically and laterally. The small rings marked on the body illustration indicate the points on the body of which the measurements are given in the table. Reading off the measurements is done by looking up the number of the ring in the table where the value concerned is given.

For example: a new front member is to be fitted. This is fixed with the measurements ⑭ and ⑰. Point 14 is first looked up in the table. This indicates $C_L = 448$, length = -427

and height = 551. The measurement $C_L = 448$ indicates the position of the point outwards from the centre line of the car, the longitudinal measurement - 427 means that the position of the point is 387 mm in front of the front axle (the zero co-ordinate through the front axle), and the vertical measurement 551 mm gives the position of the point reckoned from the O co-ordinate in the longitudinal direction of the car. In the same way, point 17 is located 723.5 mm from the centre line of the car, 660 mm behind the front axle and 664.5 mm vertically.

Body measurement and weight

Overall length	4285 mm (168.7")
width	1618 mm (63.7")
height	1235 mm (48.6")
weight	315 kg (693 lb)

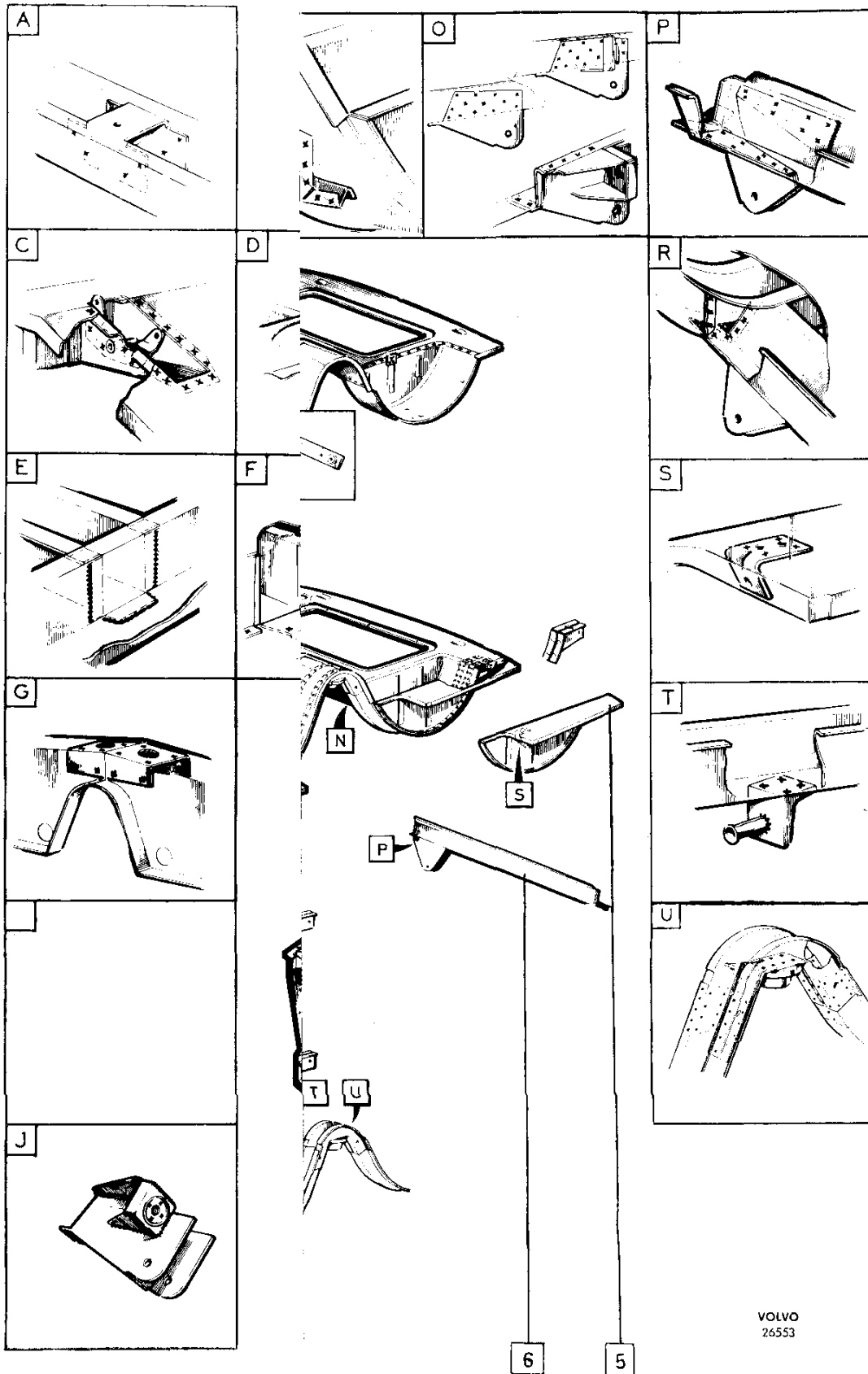

VOLVO
26553

- 9. Seat support
- 10. Cantrail, inner

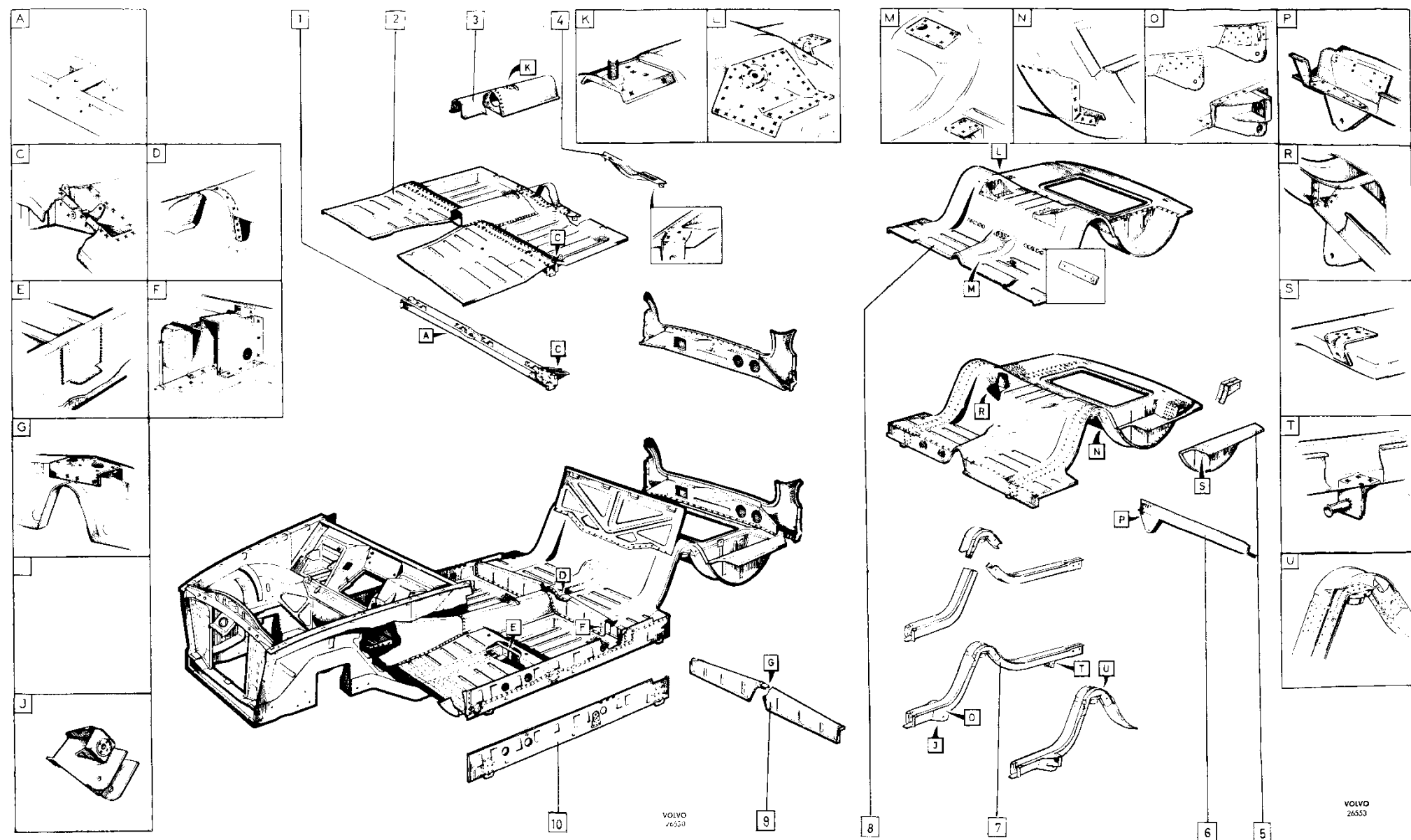

- 1. Cross-member
- 2. Floor
- 3. Tunnel
- 4. Reinforcing member
- 5. End plate

Illustration I. Floor and frame section (two- and four-door model)

- 6. Cross-member
- 7. Side member
- 8. Floor, rear section
- 9. Seat support
- 10. Cantrail, inner

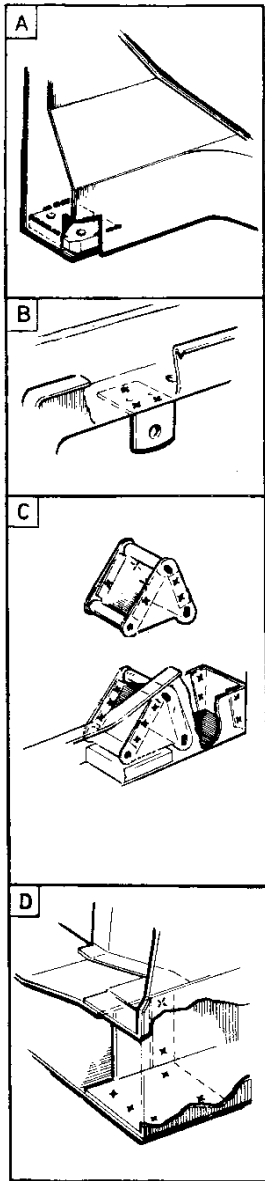

- 1. Wheel housing
- 2. Reinforcement

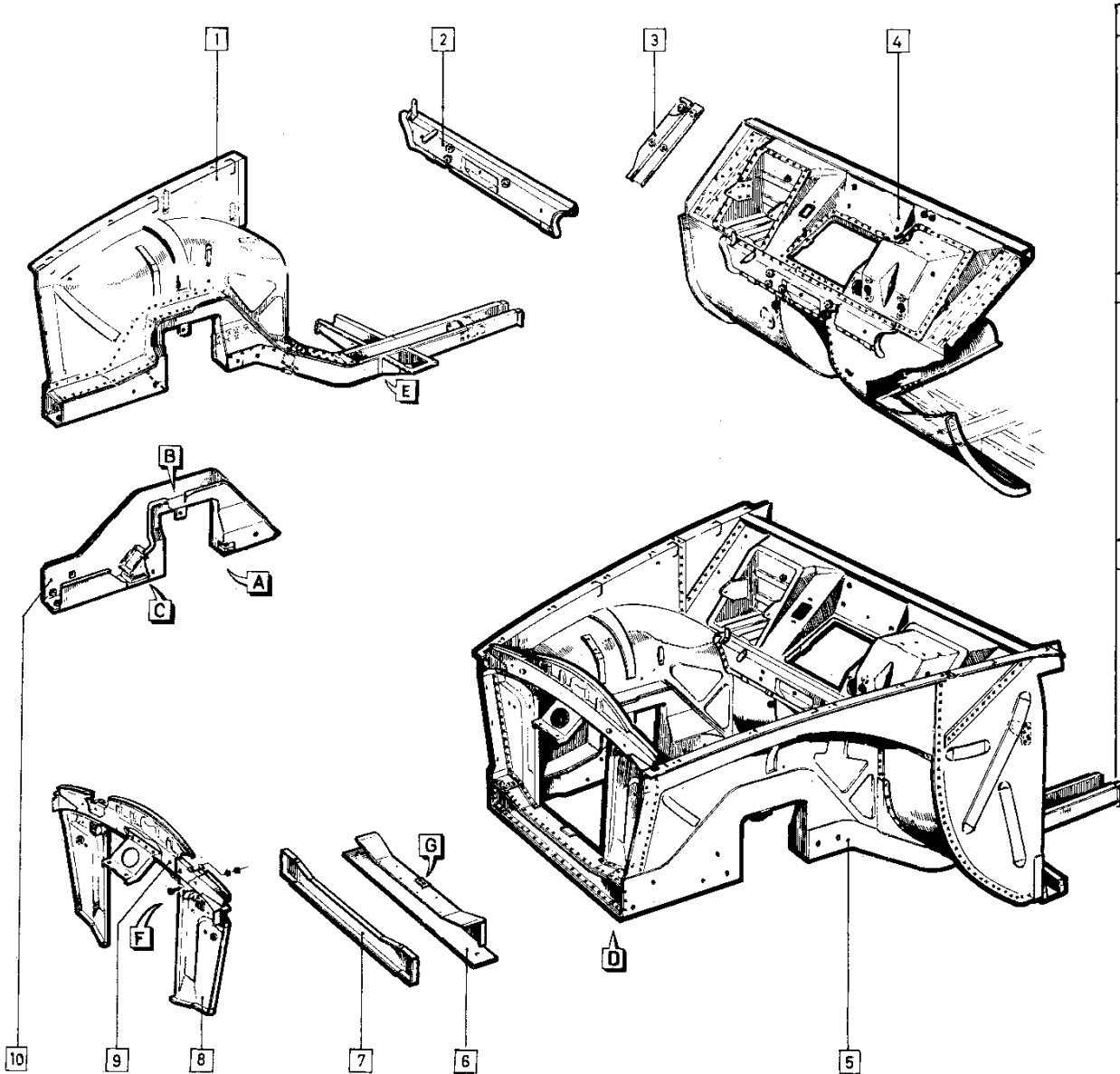

- 3. Reinforcement for hinge
- 4. Bulkhead
- 5. Front section, assembled

Illustration II. Cowl section (two- and four-door model)

- 6. Cross-member
- 7. Cover plate
- 8. Side plate
- 9. Support member
- 10. Side member

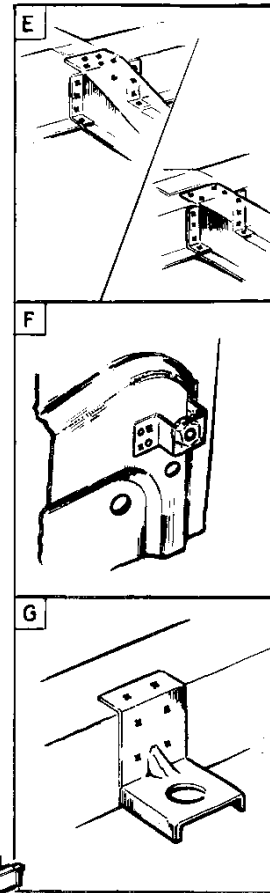

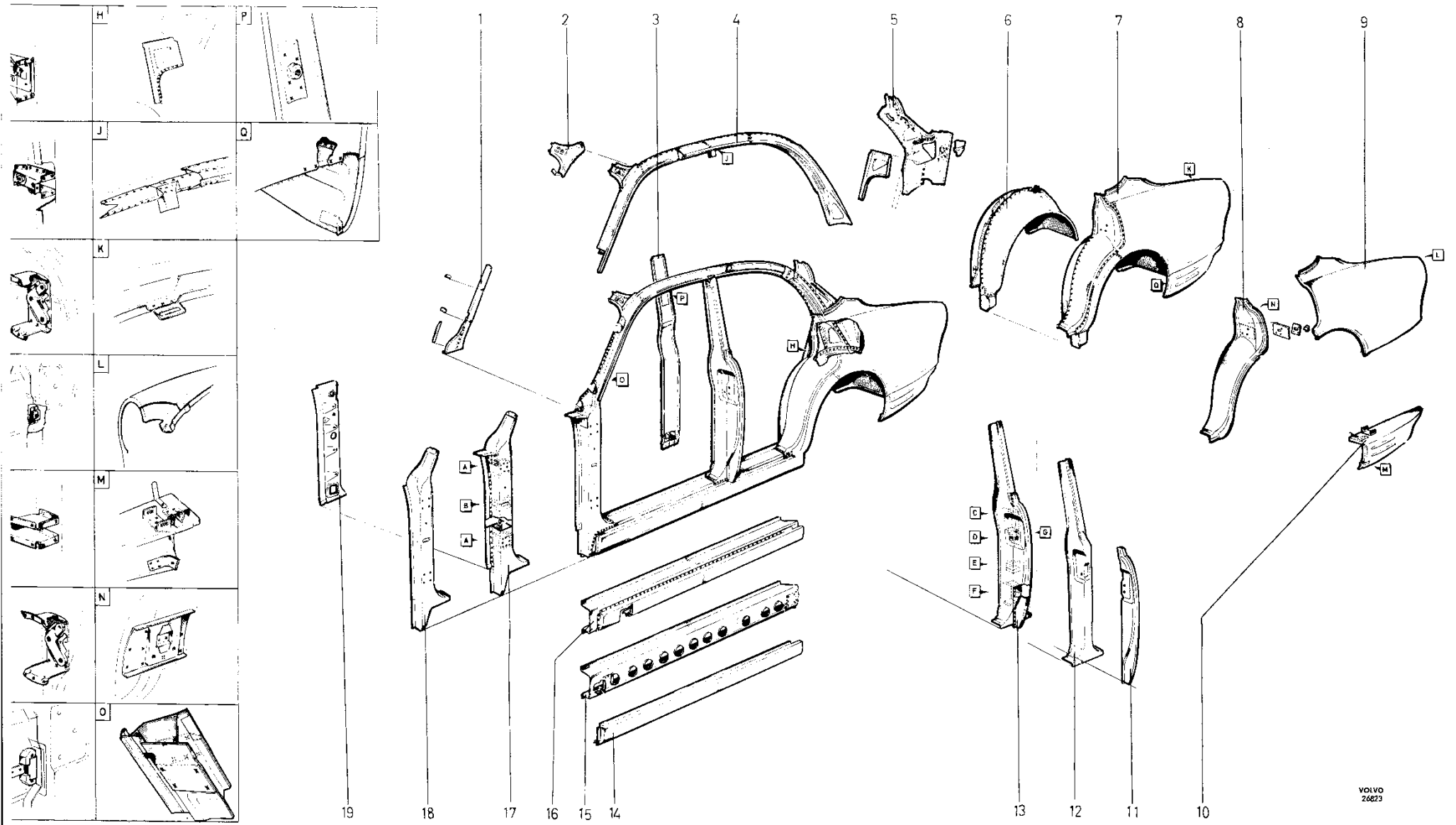

- 1. Windscreen pillar
- 2. Joint plate
- 3. Cover plate
- 4. Roof rail
- 5. Joint plate
- 6. Wheel housing
- 7. Rear mudguard, rear pillar, wheel housing
- 8. Rear pillar (C-pillar)
- 9. Rear mudguard

Illustration III. Side section (four-door model)

- 10. Lower section
- 11. Centre pillar, inner part
- 12. Centre pillar, outer part
- 13. Centre pillar, complete (B-pillar)
- 14. Outer rail
- 15. Cantrail
- 16. Cantrail with outer rail welded on
- 17. Front pillar, complete (A-pillar)
- 18. Front pillar, outer part
- 19. Front pillar, inner part

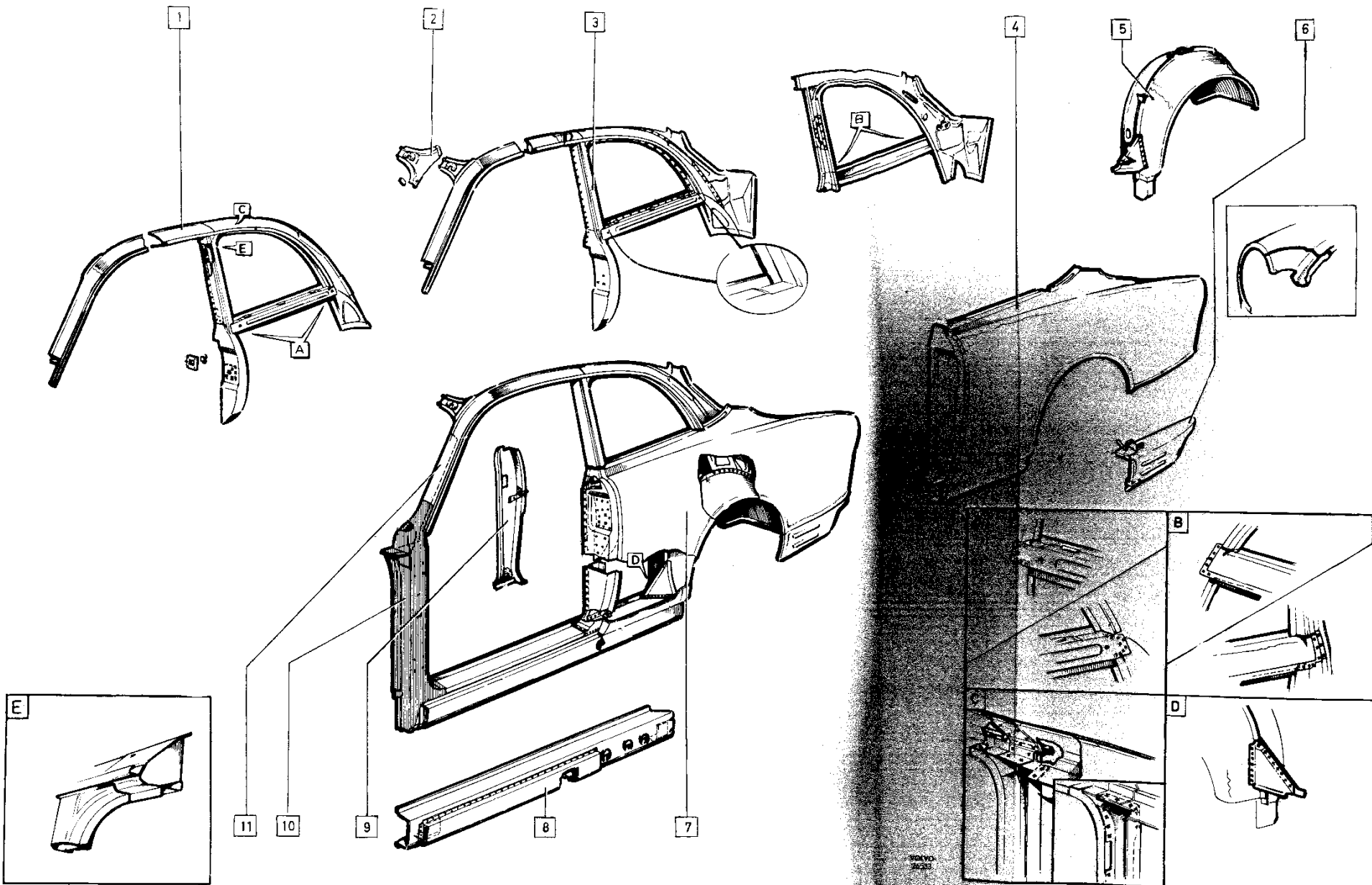

- 1. Roof rail
- 2. Joint plate
- 3. Rear door pillar
- 4. Rear mudguard
- 5. Wheel housing
- 6. Lower section

Illustration IV. Side section (two-door model)

DAVVO
1933

- 7. Rear mudguard, in position
- 8. Centrall, complete
- 9. Cover plate
- 10. Front pillar
- 11. Windscreen pillar

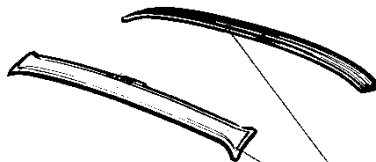
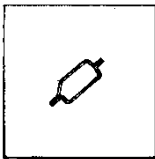
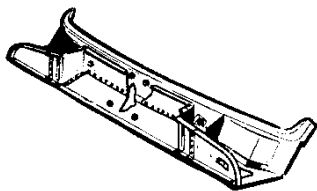
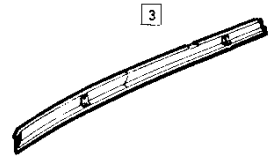
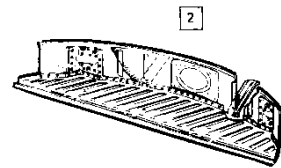
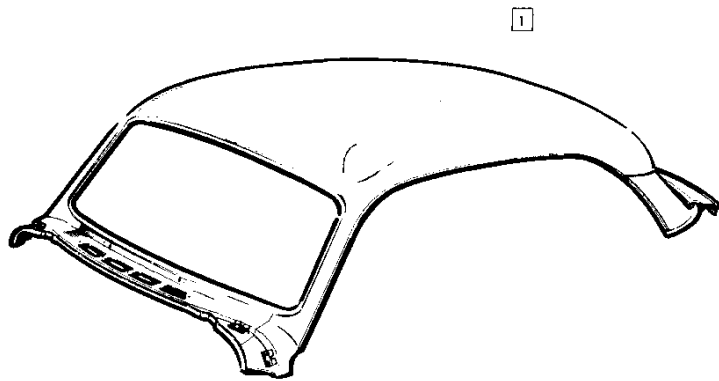

VOLVO
26551

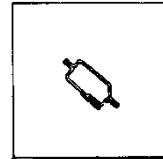

1. Roof plate
2. Ledge
3. Member, upper

Illustration V. Roof section (two- and four-door model)

4. Centre pillar
5. Member over rear window
6. Air intake
7. Upper part of cowl

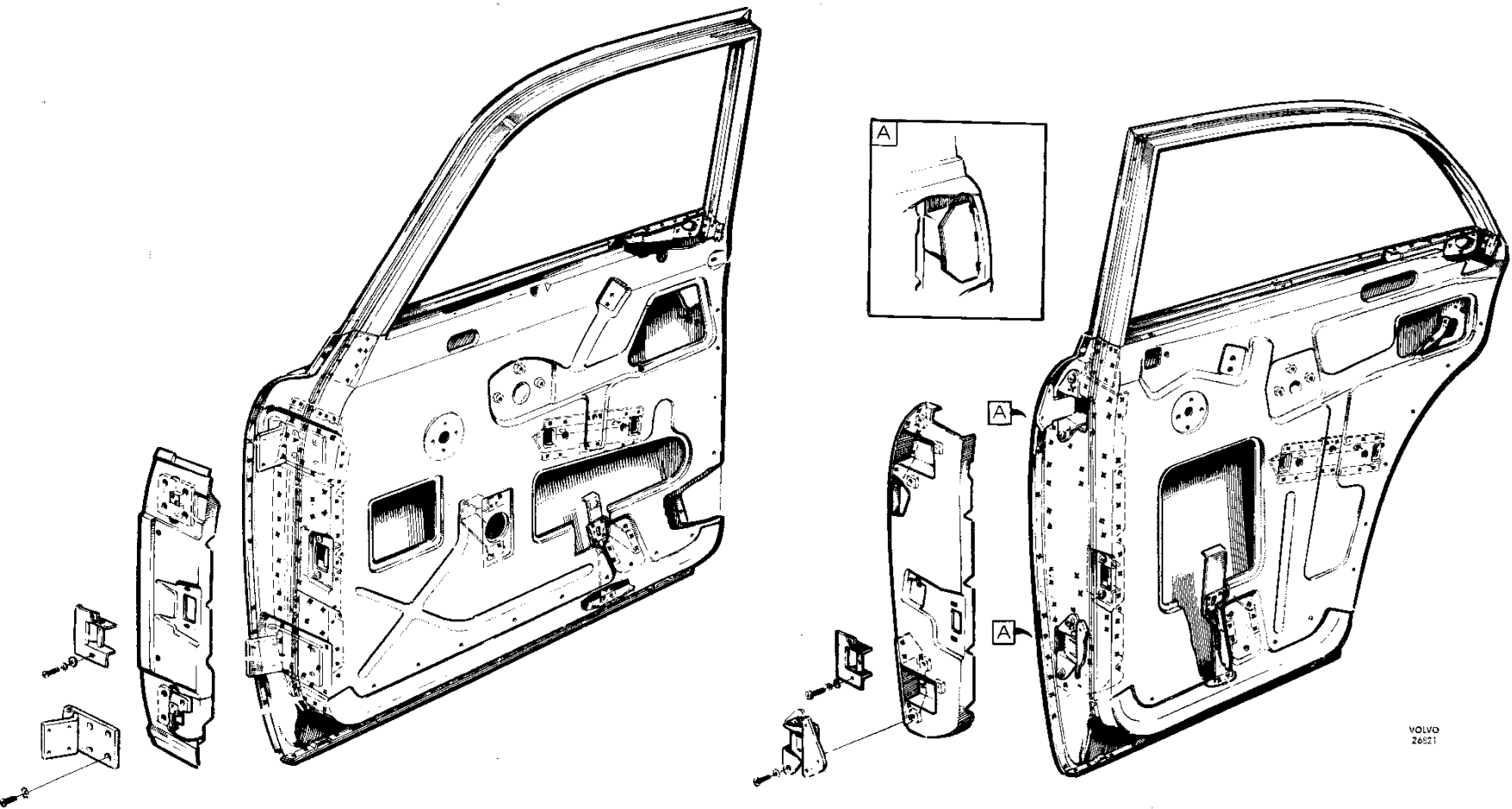
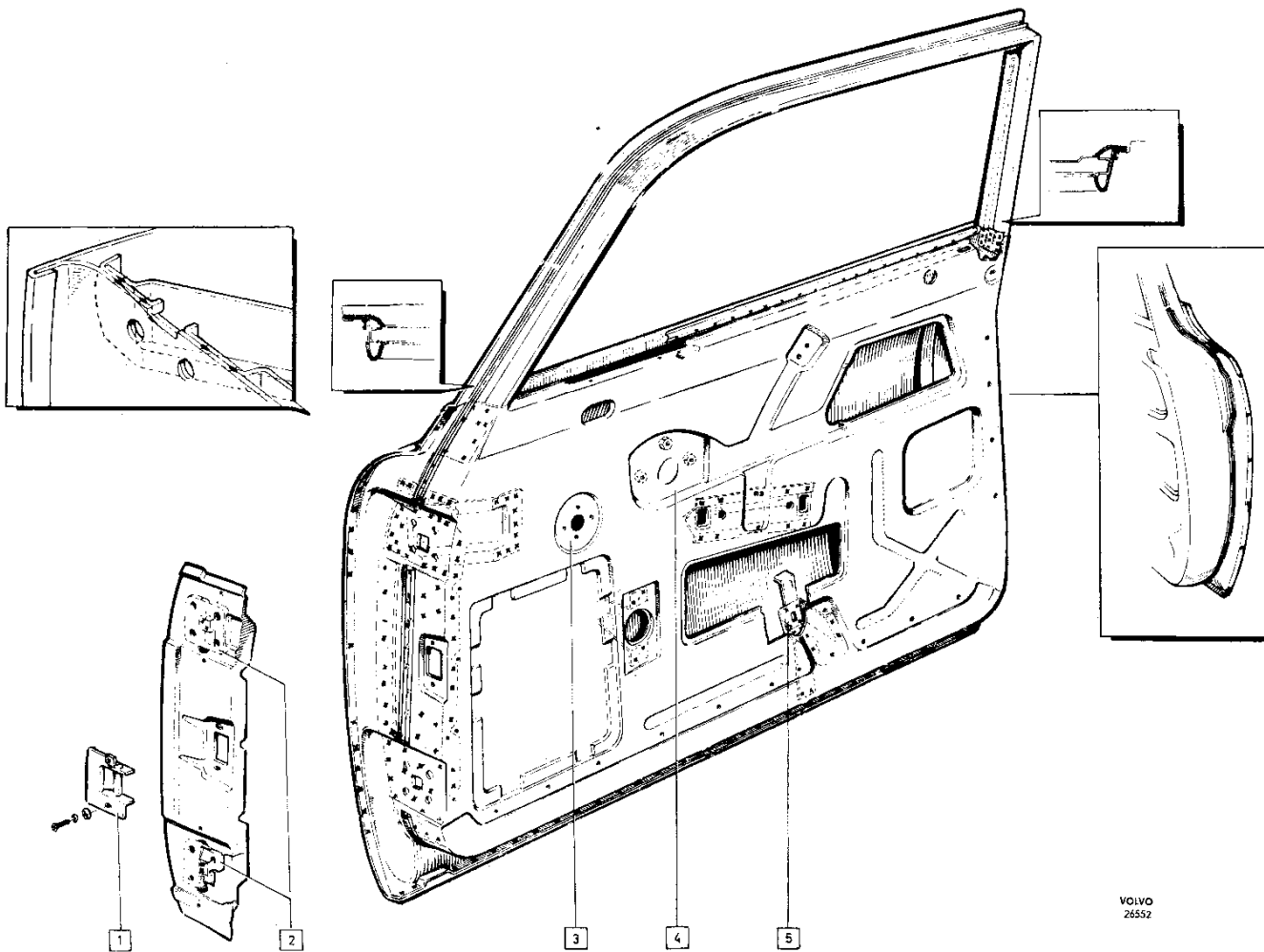

Illustration VI. Front and rear doors (four-door model)



VOIVO
26552

1. Attachment for door stop roller
2. Nut plate for attaching hinge
3. Attachment for window winder

Illustration VII. Door (two-door model)

4. Attachment for remote control
5. Attachment for window winder adjusting device

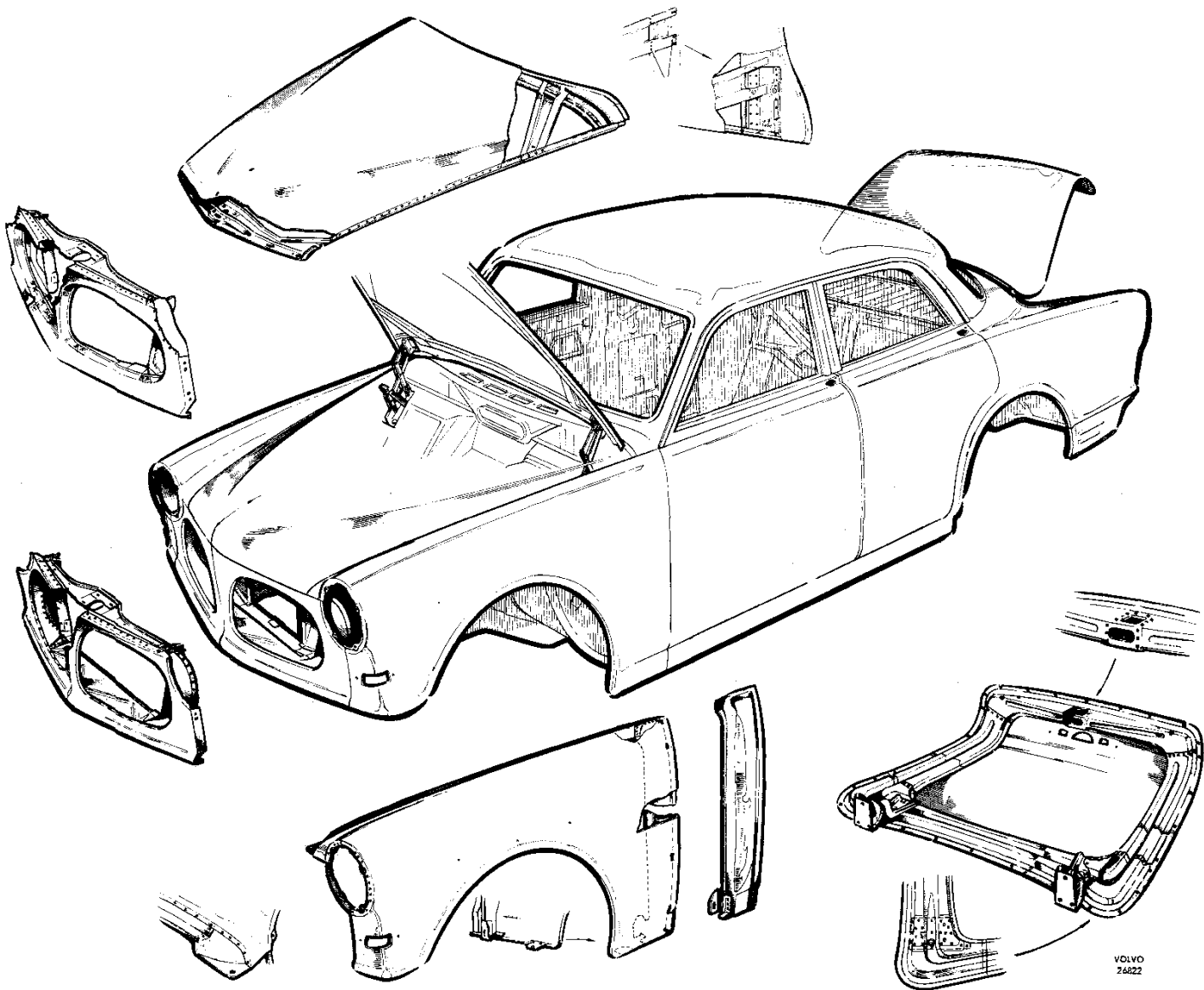

VOLVO
26822

Illustration VIII. Body, complete (four-door model)

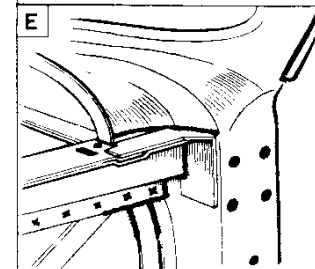
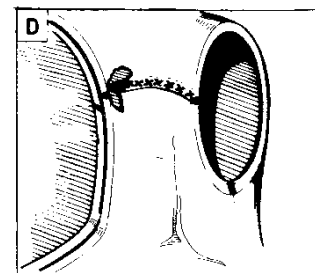
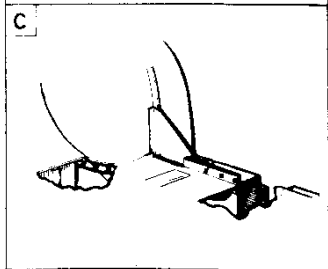
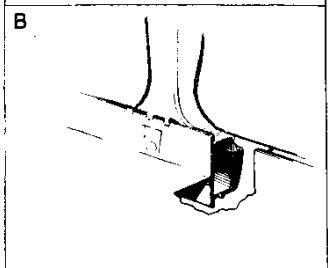
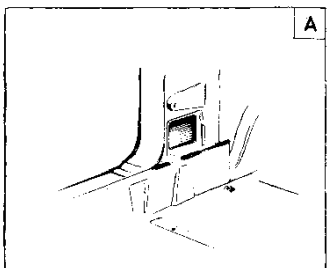
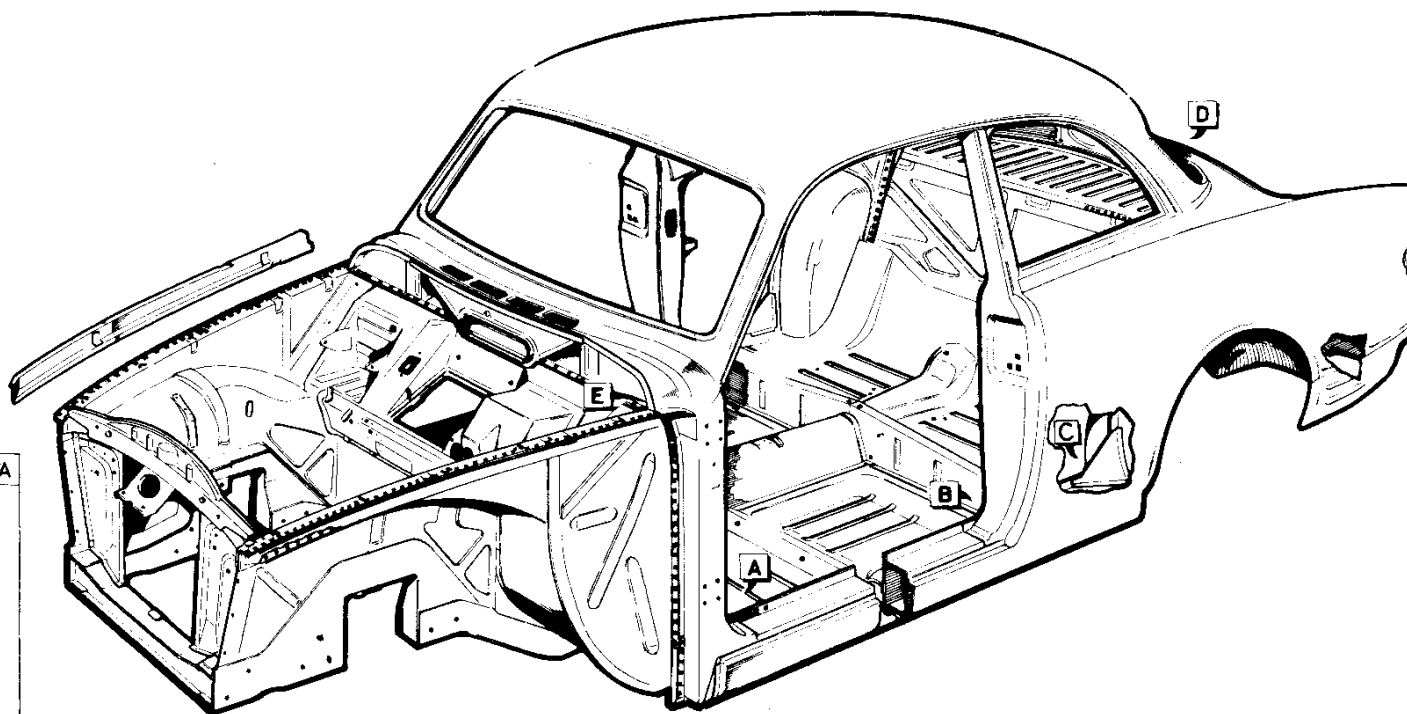

Illustration IX. Body, complete (two-door model)

VOLVO
26554

