

## List of contents 51

Description .....	1
Repair instructions .....	7
Battery .....	7
Starter motor .....	9
Dynamo .....	17
Charging control .....	23
Distributor .....	25
Headlights .....	28
Flashers and parking lights .....	32
Rear lights .....	32
Number plate lighting .....	32
Instrument and interior lighting .....	33
Lighting switch .....	33
Direction indicator switch .....	34
Horn .....	34
Windscreen wiper .....	35
Electrical leads .....	37
Leads for extra equipment .....	37
Fuses .....	37
Heater .....	38
Windscreen washer .....	38
Fault tracing .....	40
Specifications .....	43

## DESCRIPTION

The electrical system of P 1200 with effect from chassis number 84300 is made for a voltage of 12 V. The equipment can be divided up into the follo-

wing main parts: battery, dynamo, charging control, starter motor, ignition system, lighting and signalling devices and instruments.

## Battery

The battery, Fig. 1, is placed on a shelf on the right of the bulkhead. It is a 12-volt lead battery consisting of 6 cells. The battery has a capacity of 60 ampere-hours.

## Starter motor

The starter motor, Fig. 2, is fitted on the flywheel housing on the left-hand side of the engine. It consists of a 4-pole series-wound motor. The pinion on the starter motor rotor shaft is movable axially to obtain engagement with the flywheel ring gear. The pinion is controlled by a solenoid.

Fig. 1. Battery.

- |                      |                   |
|----------------------|-------------------|
| 1. Negative terminal | 6. Battery casing |
| 2. Filling plug      | 7. Negative plate |
| 3. Cell connection   | 8. Spacer         |
| 4. Positive terminal | 9. Positive plate |
| 5. Protecting grid   |                   |

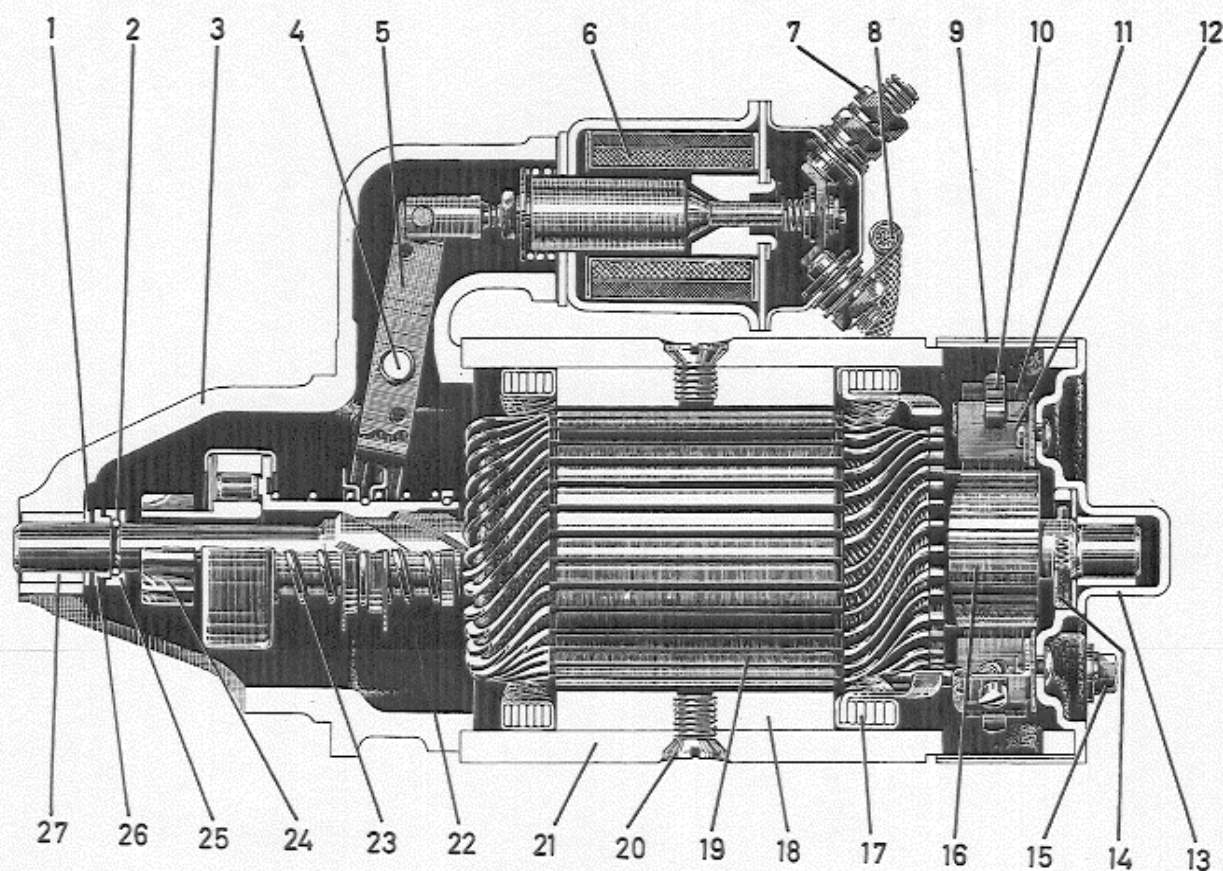
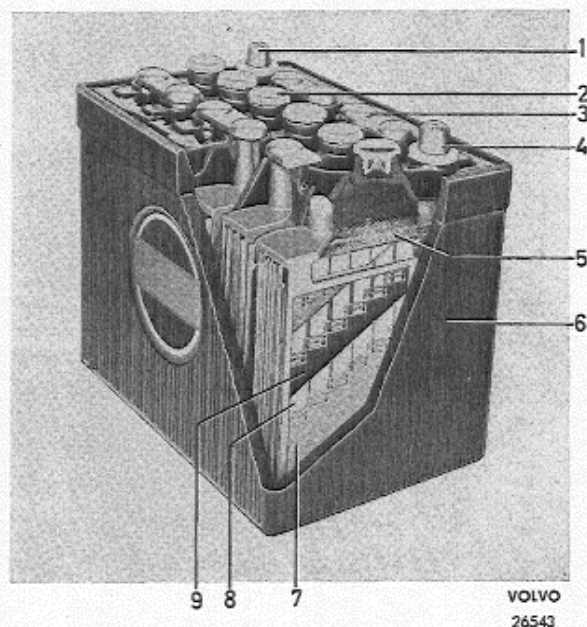


Fig. 2. Starter motor.

# Dynamo

The dynamo, Fig. 3, is placed on the right-hand side of the engine and driven by a V-belt from the crankshaft. The dynamo is of the shunt type, that

is to say, the rotor and field windings are coupled in parallel. The charging capacity of the dynamo is regulated by a charging control.

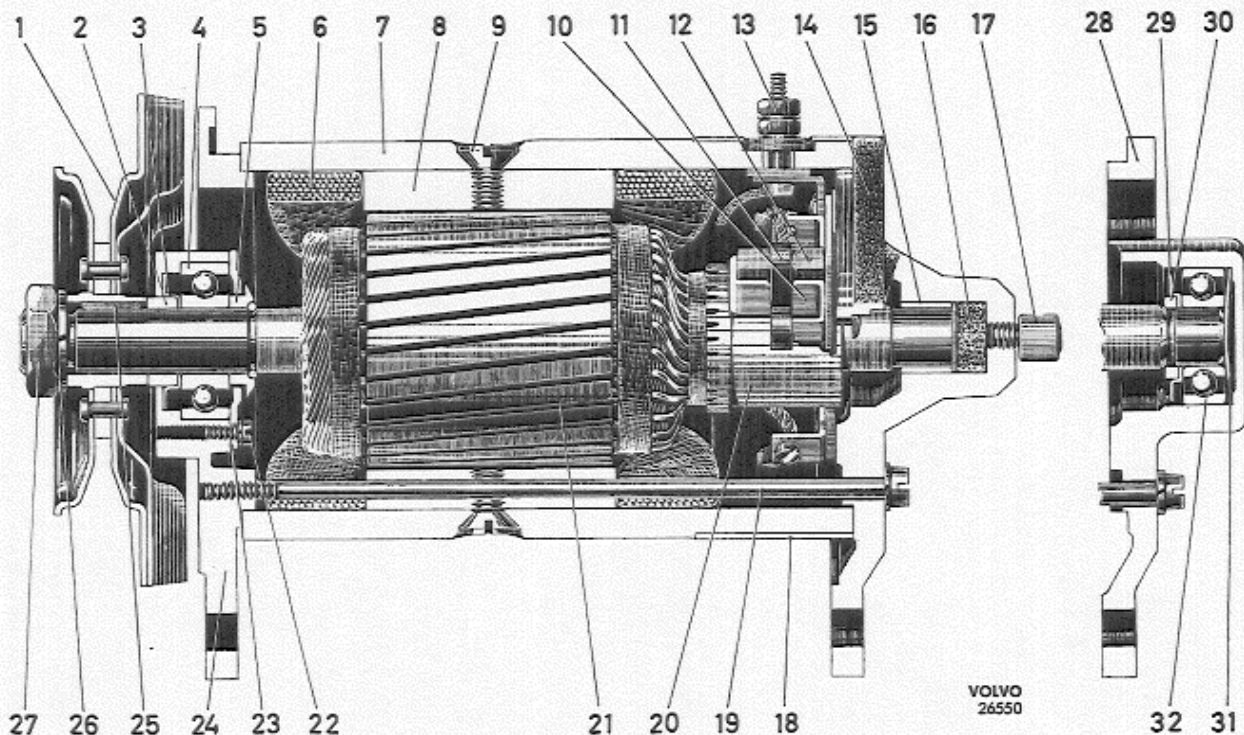


Fig. 3. Dynamo.

- |                    |                      |                     |
|--------------------|----------------------|---------------------|
| 1. Belt pulley     | 13. Terminal screw   | 25. Key             |
| 2. Spacing ring    | 14. End head         | 26. Spring washer   |
| 3. Oil seal washer | 15. Bushing          | 27. Nut             |
| 4. Ball bearing    | 16. Lubricating felt | 28. End head        |
| 5. Spacing ring    | 17. Lubricating cup  | 29. Oil seal washer |
| 6. Field winding   | 18. Protecting band  | 30. Spacing ring    |
| 7. Stator          | 19. Screw            | 31. Spring ring     |
| 8. Pole shoe       | 20. Commutator       | 32. Ball bearing    |
| 9. Pole screw      | 21. Rotor            |                     |
| 10. Brush holder   | 22. Screw            |                     |
| 11. Brush spring   | 23. Sealing washer   |                     |
| 12. Brush          | 24. End head         |                     |
- Dynamo type AR 6
- Dynamo type AR 7

## Text for Fig. 2. Starter motor.

- |                     |                    |                   |                 |
|---------------------|--------------------|-------------------|-----------------|
| 1. Adjusting washer | 8. Main lead       | 15. Bolt          | 22. Spring      |
| 2. Locking ring     | 9. Protecting band | 16. Commutator    | 23. Spring      |
| 3. End head         | 10. Brush spring   | 17. Field winding | 24. Pinion      |
| 4. Shaft            | 11. Brush          | 18. Pole shoe     | 25. Stop washer |
| 5. Engaging lever   | 12. Brush retainer | 19. Rotor         | 26. Stop washer |
| 6. Solenoid switch  | 13. End head       | 20. Pole screw    | 27. Bushing     |
| 7. Terminal stud    | 14. Rotor brake    | 21. Stator        |                 |

## Charging control

The charging control, Fig. 4. is fitted on the bulkhead. The charging control is of the variode type,

that is to say, current limitation is done by means of a variode. In addition to the variode, the charging control consists of a reverse current relay and voltage control.

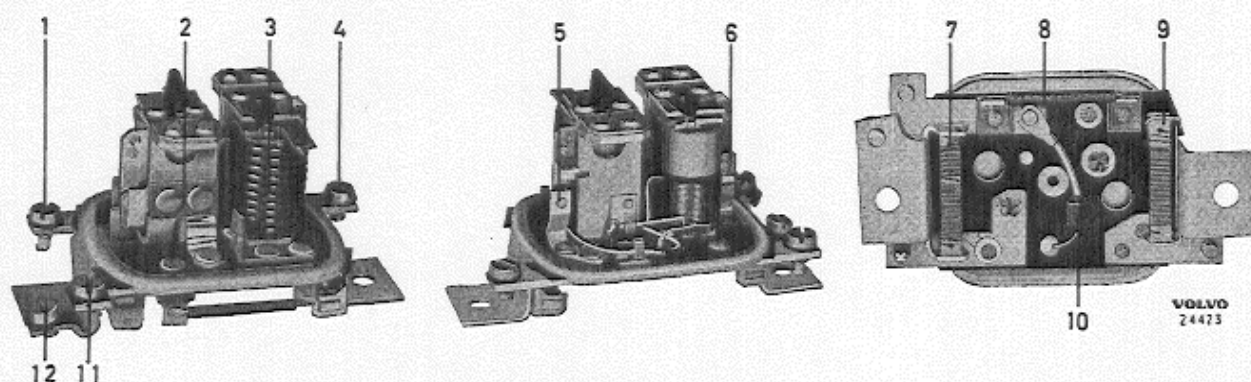


Fig. 4. Charging control.

- |                    |                       |
|--------------------|-----------------------|
| 1. Terminal, DF    | 7. Resistance wR      |
| 2. Voltage control | 8. Variode resistance |
| 3. Cut-in relay    | 9. Resistance aR      |
| 4. Terminal, B+    | 10. Variode           |
| 5. Cut-in contact  | 11. Terminal D+, 61   |
| 6. Control contact | 12. Earth connection  |

## Ignition system

The ignition system is of the battery ignition type. It consists of the following main parts: ignition coil, distributor, ignition leads and sparking plugs.

### Ignition coil

The ignition coil is placed on the left-hand side of the bulkhead.

The purpose of the ignition coil is to transform the battery voltage to high-tension voltage for the sparking plugs. It consists of a core of laminated metal around which is a winding of heavy copper wire, the primary winding, and a winding of fine copper wire, the secondary winding. The primary winding operates with battery voltage from the distributor contact breakers.

The other winding, the high-tension winding, is connected to the centre terminal in the distributor cap.

From there, the high tension current is distributed to the engine sparking plugs.

## Distributor

The distributor, Fig. 5, is placed on the left-hand side of the engine and is driven from the camshaft.

The distributor has two separate electrical circuits, low-tension and high-tension. The low-tension (battery voltage) is distributed to the ignition coil by the contact breakers, the breaking function of which is actuated by a cam fitted on the distributor shaft.

The high-tension generated in the ignition coil is distributed to the sparking plugs by the rotor arm fitted on the distributor shaft.

The adjustment of the distributor in relation to engine speed is regulated by a centrifugal governor fitted under the breaker plate. The adjustment in relation to loading is controlled by a vacuum regulator.

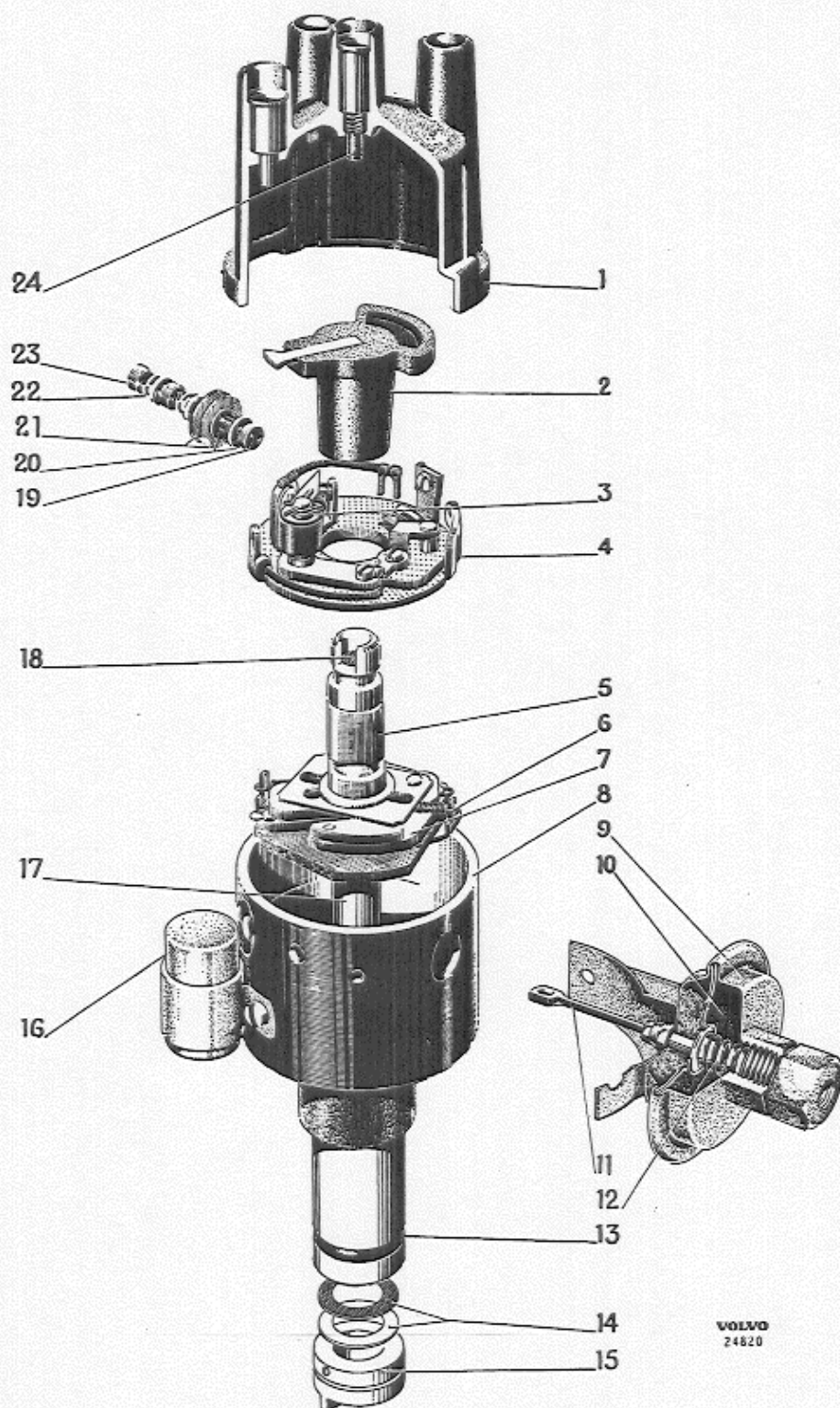


Fig. 5. Distributor.

1. Cap
2. Rotor arm
3. Contact breaker
4. Breaker plate
5. Breaker cam
6. Spring
7. Governor weight
8. Distributor housing
9. Vacuum regulator
10. Diaphragm
11. Link rod
12. Spring
13. Rubber seal
14. Washers
15. Flange
16. Capacitor
17. Distributor shaft
18. Felt packing
19. Screw
20. Flat washers
21. Insulating washers
22. Spring washer
23. Nut
24. Rod brush

VOLVO  
24820

## Lighting

The lighting consists of two headlights which have full and dipped positions, flashers and parking lamps, rear lamps and number plate lamp.

The headlights are fitted in the mudguards. They are switched on and off by the lighting switch fitted on the instrument panel. Switching between full and

dipped headlights is done by means of the foot dipper switch fitted in the floor.

The parking lamps are placed below the headlights and contain bulbs for the parking lights and direction indicators.

The rear lamps have two bulbs for rear lights, stop lights and direction indicators.

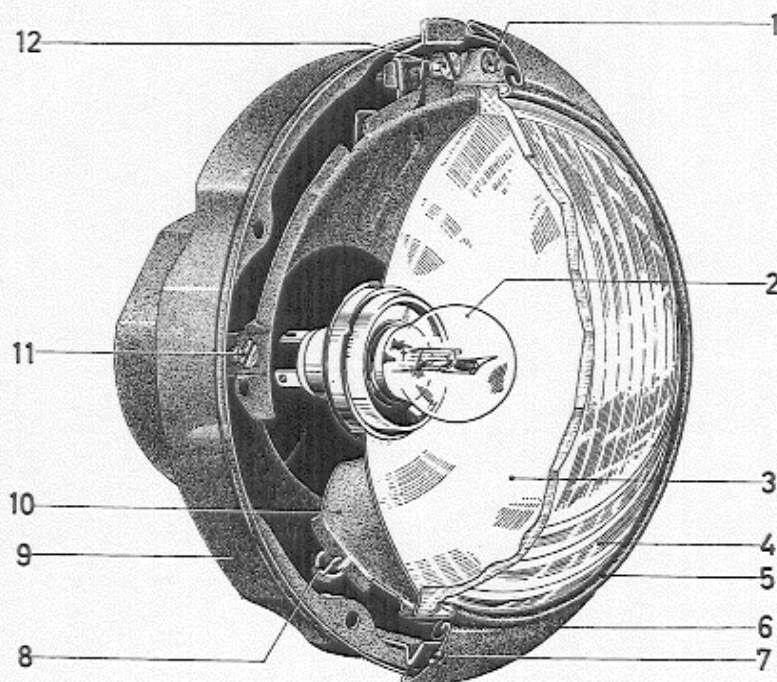


Fig. 6. Headlight.

1. Attaching screw for headlight insert
2. Full and dipped headlight bulb, asymmetrical
3. Reflector
4. Glass
5. Sealing ring
6. Outer ring
7. Screw for outer ring
8. Spring
9. Outer casing
10. Bowl
11. Screw for horizontal adjustment
12. Screw for vertical adjustment

VOLVO  
26684

## Switches

The lighting switch consists of a combined pull and turn switch.

The pulling motion is used for switching on the vehicle lighting and the turning motion for controlling the strength of the instrument lighting.

The direction indicator switch lever is placed on the steering column. The switch is provided with automatic return. The headlight signal is operated

by means of the switch lever fitted on the steering column. Full headlights are switched on by lifting the lever towards the steering wheel.

The switch for the windscreen wiper is provided with positions for full and half speed, and for windscreen washing. The windscreen wiper functions when the switch is pulled out the first and second steps. The windscreen washer operates when the switch is pulled out fully.

## Horns

The horns, Fig. 7, are fitted in front of the radiator. One of these gives a low note and the other a high note. Operation is by means of the horn ring fitted on the steering wheel.

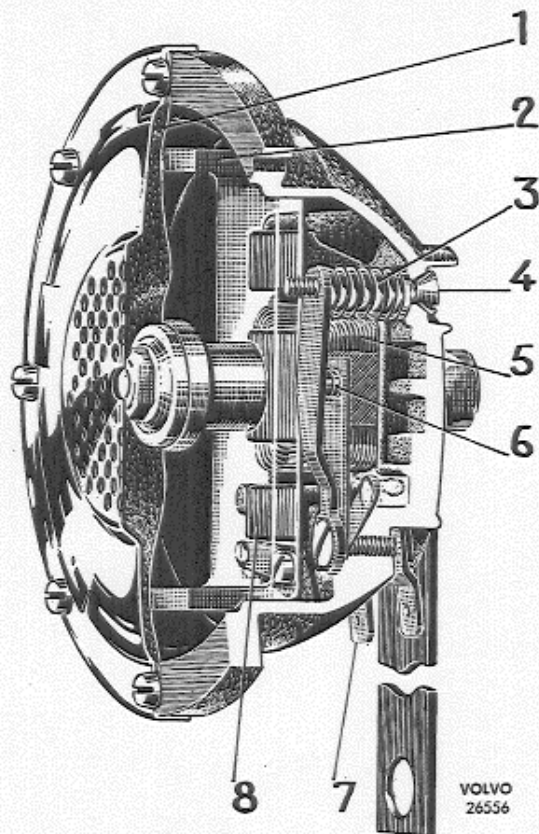


Fig. 7. Horn.

- |                     |                     |
|---------------------|---------------------|
| 1. Diaphragm        | 5. Winding          |
| 2. Armature         | 6. Breaker contacts |
| 3. Spring           | 7. AMP connection   |
| 4. Adjusting screws | 8. Iron core        |

## Windscreen wiper

The windscreen wiper, Fig. 8, is driven by an electric motor. The motor is connected to the wiper blades by means of link arms and a gear housing.

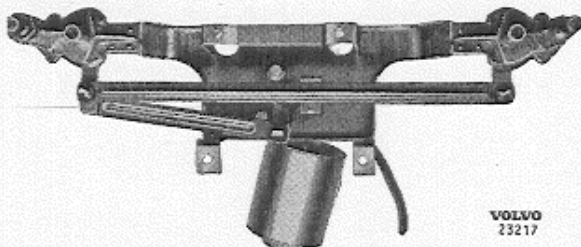


Fig. 8. Windscreen wiper.

The motor has two speeds which are selected by means of the switch fitted on the instrument panel. The windscreen wiper is self-parking.

## Direction indicators

The direction indicators are of the flasher type. These are fitted at the front and rear. The flashing action is caused by an automatic unit fitted under the instrument panel. Controlling is done by means of a lever under the steering wheel, which operates a switch.

## Fuses

The fuses consist of melt wires fitted on porcelain plugs. The wire melts when the current exceeds the value for which the fuse is intended. The fuses used are rated at 8 and 25 amps. The fuses are placed in a fusebox fitted on the bulkhead under the bonnet.

## Control lamps

The charging control lamp should go out when the engine is running. This indicates that the dynamo is charging the battery. If the lamp lights, this means that there is a fault in the dynamo. At low engine speed (idling), it is normal for the lamp to light.

The oil pressure control lamp receives current from the starting switch via the fusebox and is earthed through a pressure indicator fitted on the engine. When the engine is running and the oil pressure normal, the connection between the lamp and engine frame through the pressure indicator is broken. When the oil pressure has fallen to a pre-determined value, the pressure indicator closes the circuit and the lamp lights.

The control lamp for the direction indicators winks when one of the indication is in use. The control lamp for full headlights lights up with a weak blue glow when full headlights are switched on.

## Instruments

The speedometer is of the eddy current type and is driven by a cable from the gearbox.

The fuel gauge shows the amount of fuel in the fuel tank. The fuel gauge is controlled by a level impulse unit fitted in the fuel tank.

## REPAIR INSTRUCTIONS

### Battery

#### Removing

1. Remove the cable terminals from the battery terminal studs. Use a puller if the cable terminals are stuck to the terminal studs.
2. Unscrew the nuts for the securing bar, and lift up the battery.
3. Clean off the battery with a brush and rinse it with clean, lukewarm water.
4. Clean the battery shelf and cable terminals. Use a special steel brush or pliers for the cable terminals.

#### Fitting

1. Place the battery in position. Ensure that it is turned the right way round. Fasten the battery with the securing bar and nuts.
2. Tighten the cable terminals onto the terminal studs. The negative terminal stud of the battery should be connected to earth.
3. Coat the cable terminals and terminal studs with vaseline.

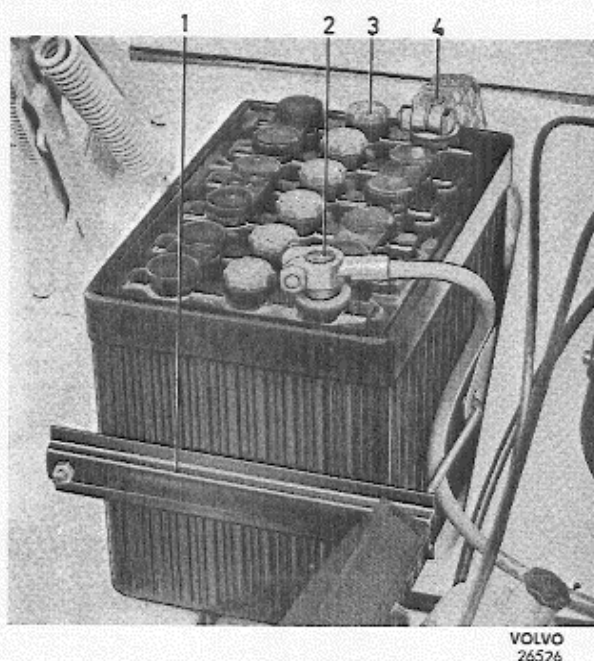


Fig. 9. Battery.

- |                  |                 |
|------------------|-----------------|
| 1. Securing bar  | 3. Filling plug |
| 2. Positive lead | 4. Earth lead   |

#### Maintenance and charging directions

In order for the battery to function satisfactorily, it must be in good order. The first condition for this is that the acid is maintained at the specified level above the plates. If the acid level is allowed to fall below the upper edge of the plates, it is not possible to utilize the full capacity, since only that part of the plates surrounded by acid can take part in charging and discharging. Ensure that the acid level comes 5 mm (3/16") above the upper edge of the spacers between the plates. Measuring is done with a glass tube. If the level is too low, top up with distilled water as necessary.

Use a filling flask as shown in Fig. 10.

NOTE. On no account must battery acid be used for this topping-up.

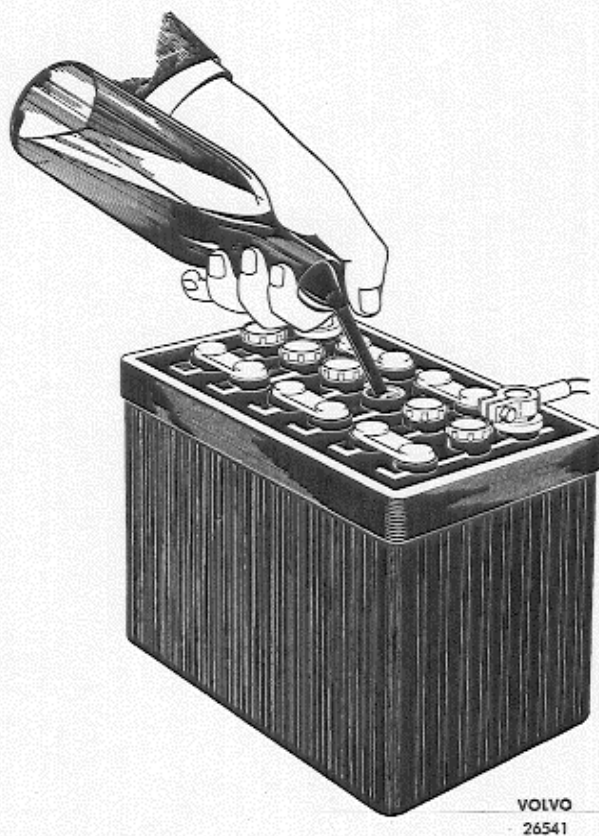


Fig. 10. Topping-up with distilled water.

Ensure that the battery is secured firmly in position. The filling plugs, connections and cable terminals should be well tightened. The cable terminals

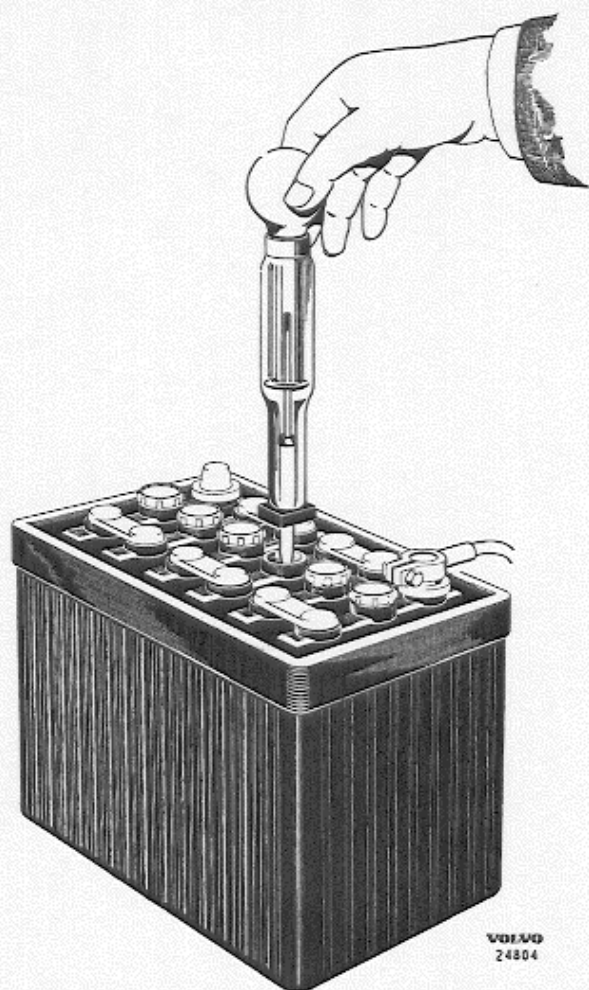


Fig. 11. Checking specific gravity of acid.

should be coated with vaseline. If the battery is found to be in a discharged condition or the specific gravity of the acid has fallen to 1.23, the battery must be lifted out and charged at a charging station. The specific gravity of the acid is measured with a hydrometer as shown in Fig. 11.

If the battery has to be removed for the above-mentioned reason, it should be lifted out and washed and rinsed externally with clean water. If the cable terminals bind on the studs, they should be pulled off with the special puller as shown in Fig. 12.

Only direct current can be used for charging. Alternating current will ruin the battery.

Connect the positive cable of the charging device to the positive terminal stud of the battery and the negative cable to the negative terminal stud, ensuring that good contact is obtained.

Unscrew the filling plugs and check the acid level. If this too low, top up with *distilled* water.

NOTE: On no account must battery acid be used for topping-up.

The filling plugs must be removed while charging is taking place, as otherwise the battery can be damaged by the pressure generated. Switch on the charging device and adjust the charging current to that stated in the specifications.

Do not use a naked flame in the charging room or in the vicinity of a battery. The gases generated are extremely inflammable, causing a great risk of explosion.

When the specific gravity of the acid has risen to 1.28 and does not rise any further during the last two hours of charging, the battery is fully charged. The voltage of the individual cells when charging is completed should be approx. 2.6 volts.

If the specific gravity mentioned above cannot be reached but remains constant at a lower value in spite of several hours charging at the prescribed current, the specific gravity should be adjusted to 1.28. This is done by sucking out a certain quantity of the electrolyte and replacing it with battery acid

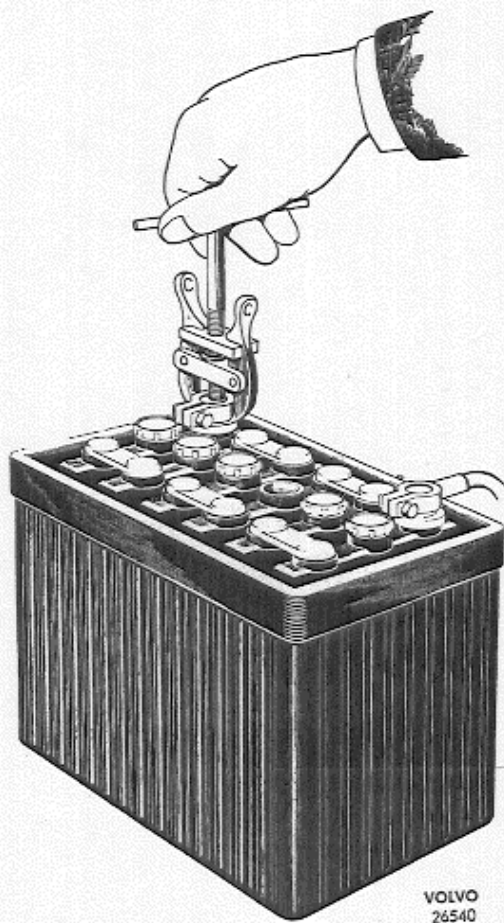


Fig. 12. Removing battery cable terminal.

having a specific gravity of 1.36. Charge for a further half hour in order to mix the electrolyte and acid properly.

If the specific gravity of the acid is higher than 1.28 when charging is completed, this is adjusted by filling up with distilled water after a certain amount of the electrolyte has been sucked out. After filling up, always check that the level is correct.

When the battery is fully charged, charging is discontinued. Screw in the filling plugs and rinse the battery externally with clean water.

When fitting the battery into the vehicle, ensure that it is properly in its position, that the cable ter-

minals are cleaned and carefully tightened and then coated with vaseline. The best way of cleaning the cable terminals is with a special pair of pliers as shown in Fig. 13.

In order to obtain an idea of the condition of the battery under loading, it can be tested with a cell tester. During 10—15 seconds discharging, the voltage must not be less than 1.6 V per cell and the variation not greater than 0.2 V.

The specific gravity of the electrolyte at 15° C (60° F) and at various charging conditions of the battery is as follows:

Charging condition	Specific gravity of electrolyte
Fully charged (1/1)	1.28
Three-quarters charged (3/4)	1.24
Half-charged (1/2)	1.21
Quarter-charged (1/4)	1.16
Discharged (0)	1.12

## Starter motor

### Removing

1. Remove the cable terminal from the battery negative terminal studs.
2. Disconnect the leads from the starter motor.
3. Unscrew the bolts which hold the starter motor to the flywheel housing and lift it off.
4. Wipe off the starter motor externally with a piece of cloth soaked in petrol.

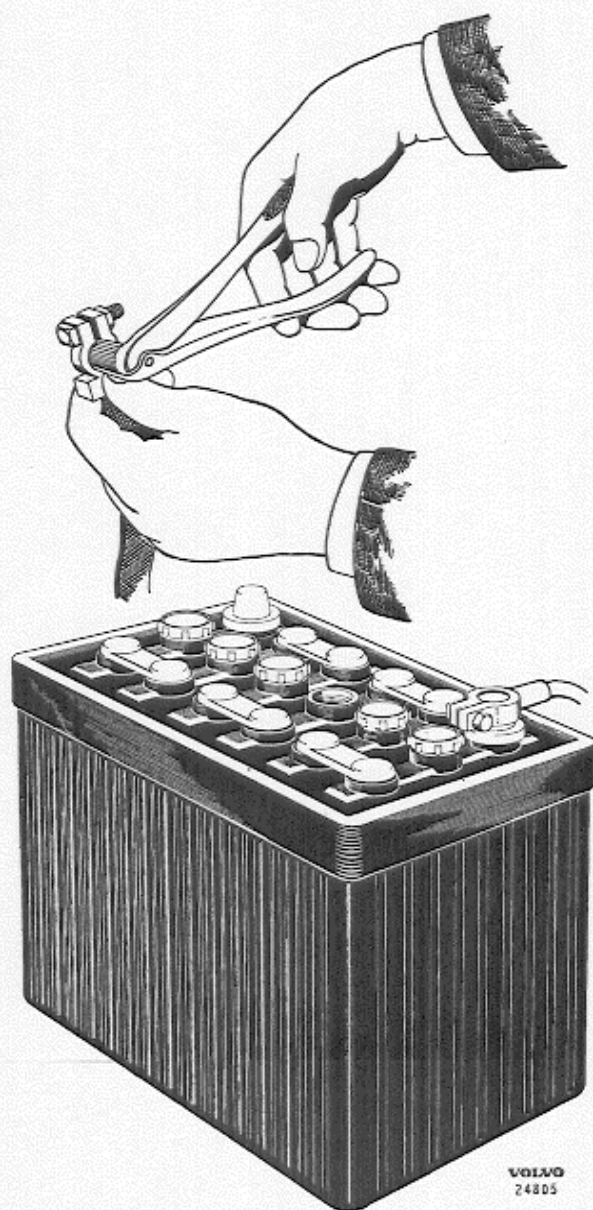


Fig. 13. Cleaning battery cable terminal

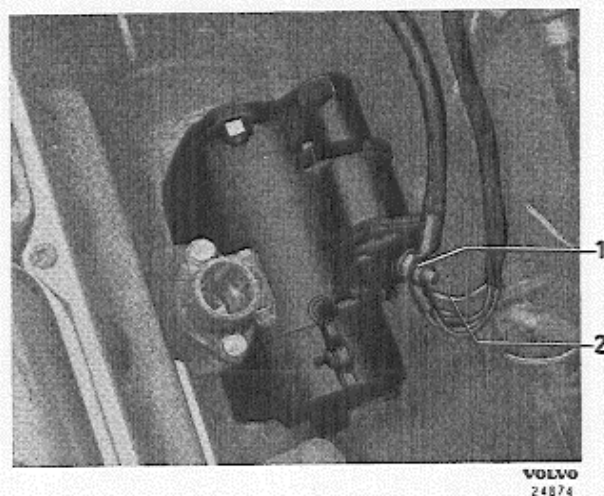


Fig. 14. Starter motor fitted.

1. Battery lead
2. Control lead

## Fitting

Fitting is carried out in the reverse order to removing. Tighten the bolts evenly, but not too tightly. Connect the leads carefully.

## Measures to be taken before dismantling

If the starter motor shows signs of not functioning satisfactorily, or perhaps not at all, first make sure that it is not the battery, leads, starter contact or solenoid that are out of order.

If the trouble is localized to the starter motor, remove it.

Before dismantling is stated, it is important to carry out correct testing. Reliable instruments must be available if the results of the test are to be of any value.

Testing is carried out as follows:

Place the starter motor on a test bench and remove the protecting band.

Connect the starter motor to the correct voltage. The starter motor housing is connected with the negative connection. If the starter motor functions without any signs of shorting or stiffness when the

current is connected, testing is continued. Connect up a voltmeter and ammeter to a 500 A shunt. Hold a revolution counter against the shaft end of the rotor. Connect the current and read off voltage, amperage and revolutions. Also watch the brushes and commutator. Make a note of the values and observations. Compare the values with those given in the specifications for an unloaded starter motor. The following reasons can now be established:

- |                                       |                                                                                                                   |
|---------------------------------------|-------------------------------------------------------------------------------------------------------------------|
| 1. Low revolutions and low amperage.  | Excessive resistance caused by dirty commutator, worn brushes or poor spring pressure.                            |
| 2. Low revolutions and high amperage. | Shorting in field windings. The rotor drags against the pole shoes due to worn bearings or bent rotor shaft.      |
| 3. Heavy sparking, low rotation.      | Low spring pressure due to worn brushes or fatigued brush springs. Shorting or partial breakage in rotor winding. |
| 4. Excessive movement of brushes.     | Poor spring pressure or out-of-round commutator.                                                                  |

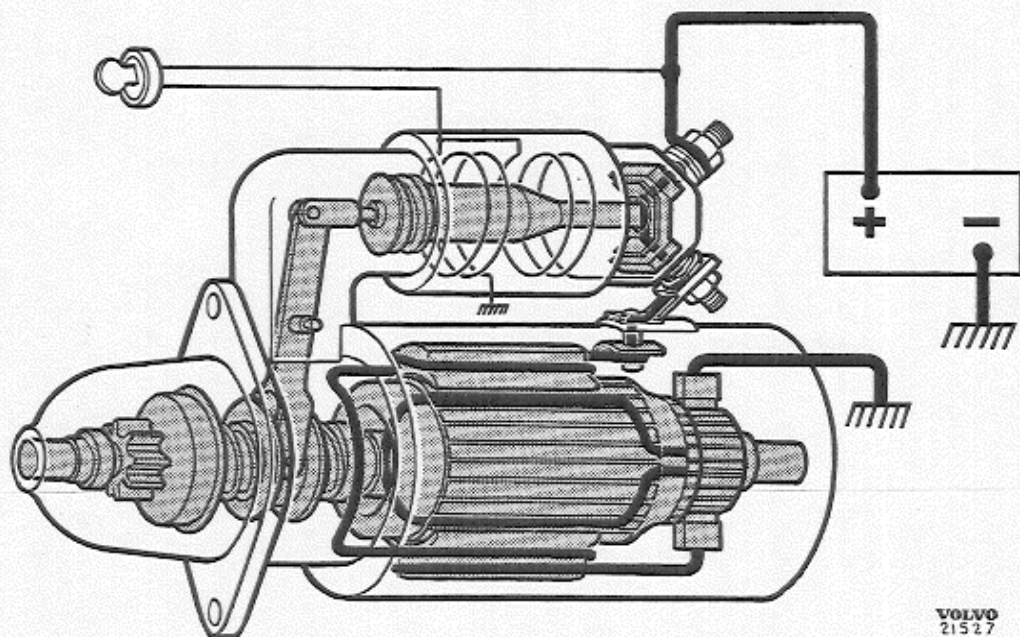


Fig. 15. Starter motor. Principle diagram.

VOLVO  
24805

Fig. 16. Removing brushes.

## Dismantling the starter motor

Dismantling the starter motor for overhaul (cleaning and lubricating) or repair, is done as follows:

1. Remove the protecting band.
2. Lift up the spring brushes and remove these, see Fig. 16.
3. Mark the position of the front and rear end heads in relation to the housing.
4. Remove the screws which hold together the above-mentioned main parts of the starter motor. Lift off the rear end head with rotor brake together with the housing after the lead between the control solenoid and housing has been removed.

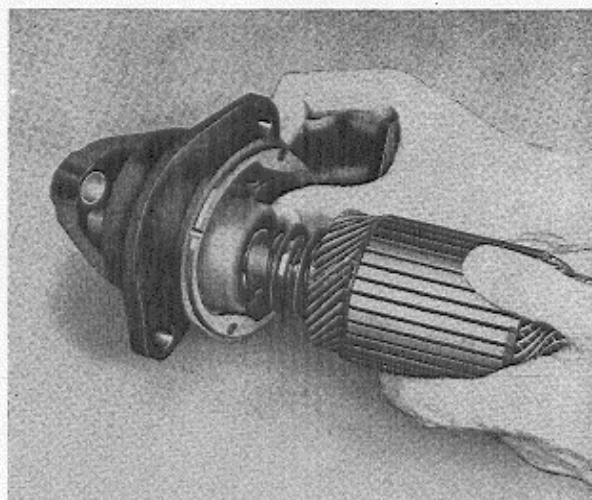
VOLVO  
24801

Fig. 17. Removing pinion and rotor.

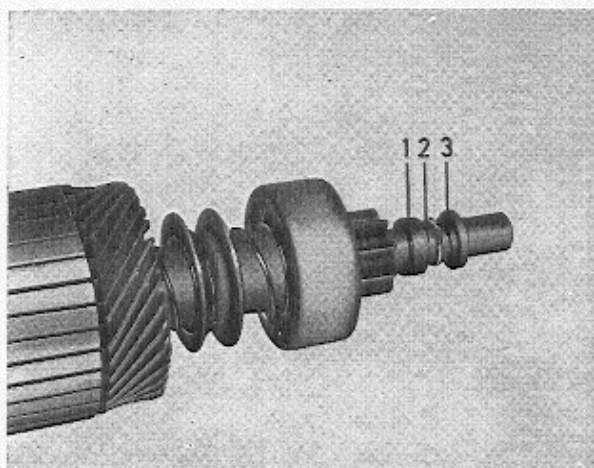
VOLVO  
24806

Fig. 18. Pinion, locking ring and nut.

1. Stop ring, inner
2. Locking ring
3. Stop ring, outer

5. Lift out the rotor with pinion from the pinion housing, see Fig. 17. This can be done after the pivot screw for the solenoid engaging fork has been removed.
6. Remove the stop washers on the rotor shaft. The thin washers (axial adjusting washers) and washer 3, Fig 18, are removed by pulling straight off the shaft. The thick washer 1, Fig. 18, is first knocked in 5—8 mm (about 1/4") on the shaft so that the locking ring 2, Fig. 18, can be removed, after which the washer is pulled off the shaft.
7. Remove the rotor brake from the rear end head.
8. Blow the starter motor housing and field winding with rotor clean from dirt and dust. Wipe off with a piece of cloth soaked in petrol. Note. Petrol mixtures such as bentyl must not be used since this can dissolve the insulation.

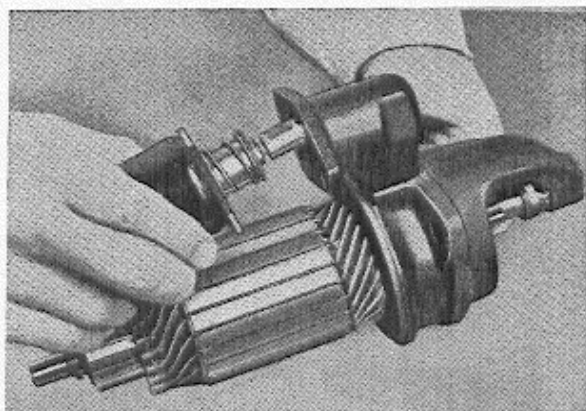
VOLVO  
21279

Fig. 19. Removing the control solenoid.

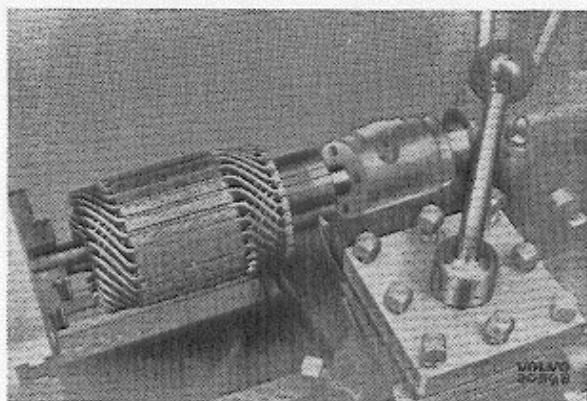


Fig. 20. Turning the commutator.

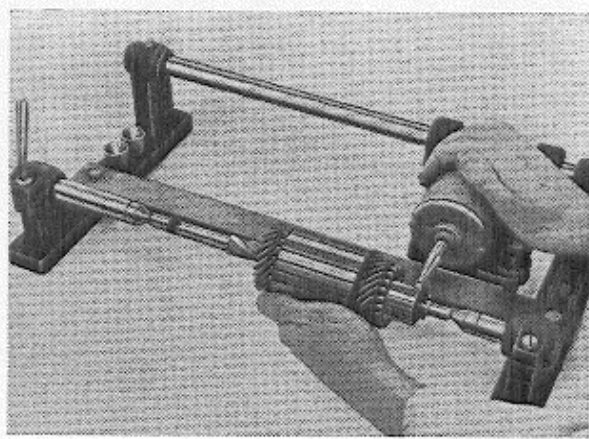


Fig. 23. Milling grooves.

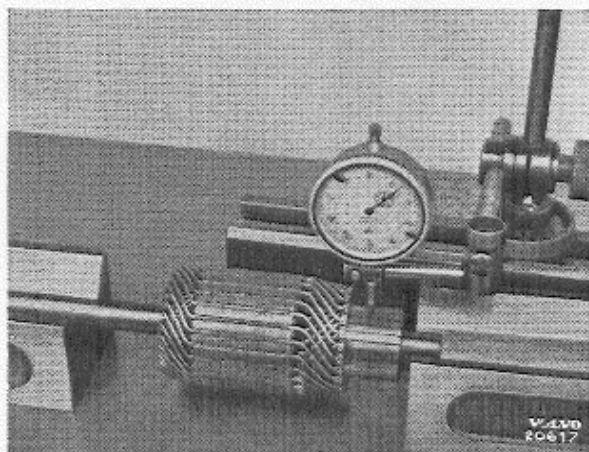


Fig. 21. Measuring rotor with dial indicator gauge.

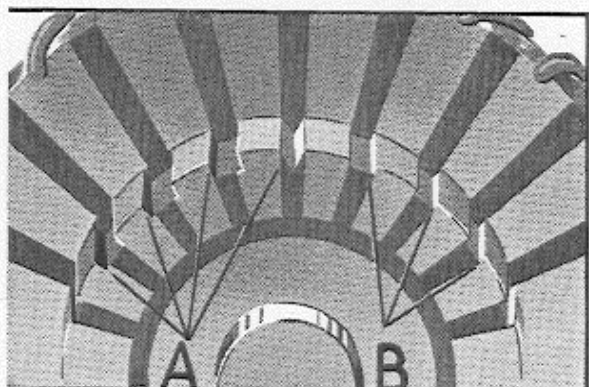


Fig. 22.

A Faulty grooving

B Correct grooving

## Inspecting

Examine the rotor for mechanical damage such as a bent or worn shaft, scored commutator and damaged winding. If the rotor shaft is bent or worn, the rotor should be replaced. Only in exceptional cases should the shaft be straightened, and this must be done in a press.

If the commutator is scored or unevenly worn, it should be turned, see Fig. 20. When doing so, a special chuck should be used, see the figure. Take small cuts every time so that no more material is removed than is necessary. If too large cuts are taken, the insulation and laminations can be damaged.

The commutator should be checked with a dial indicator gauge after turning as shown in Fig. 21. A radial throw of 0.003" (0.08 mm) can be considered permissible. The insulation between the laminations should be milled down 0.4 (0.016") below the surface of the laminations see Figs. 22 and 23. This work is carried out in a special apparatus, or if one of these is not available, with a ground-off hacksaw blade.

Examine the rotor for shorting by placing it in a growler machine. Switch on and hold a hacksaw blade a few mm from the rotor, see Fig. 24. If the blade vibrates in any position when the rotor is rotated, one of the following faults can be the reason: shorting through the rotor frame, shorting in the commutator or between the windings.

Shorting to the rotor frame is tested with the help of prods and a test lamp.

Examine the housing and field winding for damage caused by the rotor. Test that the field winding



Fig. 24. Testing the rotor.

is not earthed by connecting the contact points to the housing and field winding as shown in Fig. 25.

If the lamp lights, the winding or lead-through in the housing is damaged. Ensure that the brushes do not lie against the housing. Remove the lead-through in the housing and test again. If the lamp continues to light, the field is earthed. In this case, the field must be removed. See under "Replacing the field winding".

Examine the end head with brush holders. If any of these parts are damaged or excessively worn, they must be replaced. A bearing clearance of up to 0.12 mm (0.005") can be considered as permissible. See under "Fitting the self-lubricating bushings". Check that both the positive brush holders are not in contact with the end head, see Fig. 26.

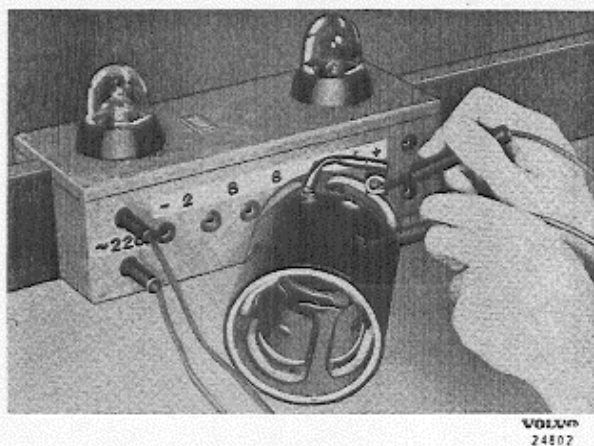


Fig. 25. Testing the field winding.

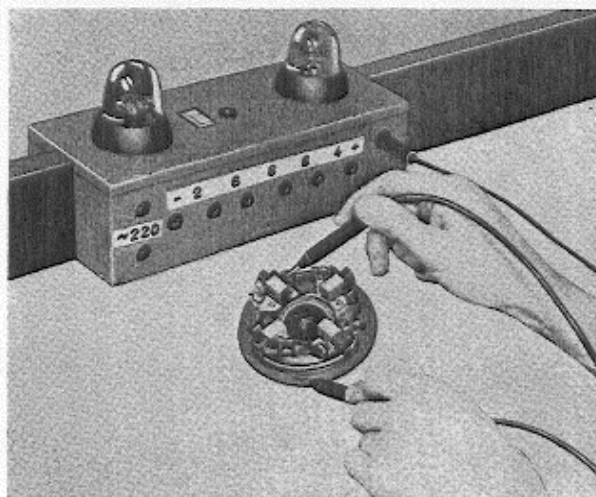


Fig. 26. Testing the brush holders.

Brushes which are damaged, scored or worn down more than half way, must be replaced.

Check the spring pressure by means of a spring balance which is hooked into the spring, see Fig. 27. The force necessary to lift the spring from the brush should lie between the values given in the specifications. If there is any deviation in the values, the springs concerned should be replaced.

Examine the pinion housing. Test the bearing on the shaft. Clearance should not exceed 0.12 mm (0.005").

Inspect the other parts and replace any which are damaged or worn. The locking rings should always be replaced with new ones, since when being removed they may have been damaged or lost their tension.

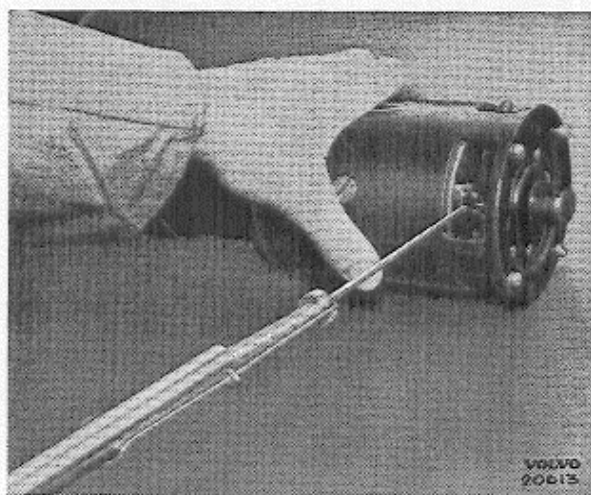


Fig. 27. Checking the brush spring tension.

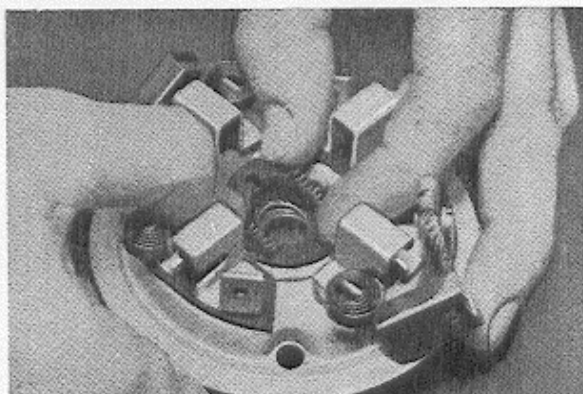
VOLVO  
21276

Fig. 28. Fitting the rotor brake.

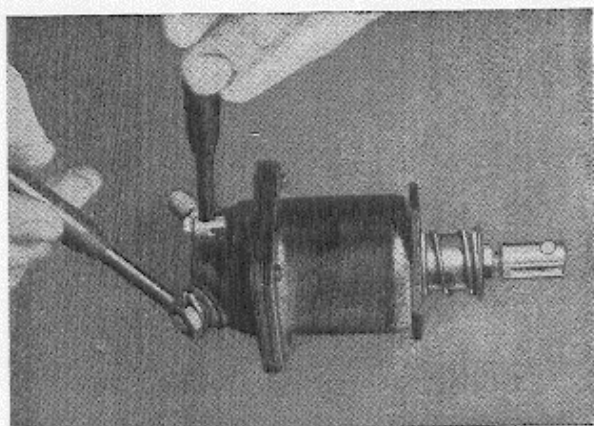
VOLVO  
21274

Fig. 29. Testing the control solenoid.

## Assembling the starter motor

1. Fit the rotor brake in the rear end head, see Fig. 28, and the lead between the positive brushes.
2. Fit the starter pinion on the rotor shaft and then place on washers and locking ring as shown in Fig. 18. Lubricate the rotor shaft in accordance with the instructions in Fig. 35.
3. Assemble the rotor and pinion housing and place the engaging arm in its position round the starter pinion. Then fit the solenoid switch on the pinion housing and place in the pivot screw.
4. Lubricate the starter pinion and engaging arm with heat-resistant ball bearing grease.
5. Place the housing on the rotor and fit it into the end head following the guide pin or marking. Place the rear end head onto the rear shaft end of the rotor and secure it in the correct position with the screws which run through. Turn the rotor and check that it rotates easily. Measure the axial clearance and compare this with the specifications. Lubricate the shaft end and bushing.

## Control solenoid

If the control solenoid does not function, first check that the battery is in good condition. If there is not fault with the battery, connect a lead between the battery positive terminal and the control solenoid contact screw for the control lead. If the control solenoid still does not engage the starter pinion and main current, should be removed from the starter

motor. If, on the other hand, it engages satisfactorily, examine the starter switch and leads.

When the control solenoid has been removed, it should be wiped clean. Then press the armature in several times and test again by connecting it to a battery. If it still does not function, the coil must be measured and the values obtained should agree with those in the specifications. A faulty control solenoid should be replaced.

Before the control solenoid is re-fitted, the distance "a" between the centre line through the pivot stud in the engaging forks and the attaching flange should be checked when the iron core is fully withdrawn, see Fig. 30. After the distance has been adjusted and the locknuts tightened, the distance "a" is checked again. The nut and fork stud are then locked with sealing paint.

Concerning the distance "a", see specifications.

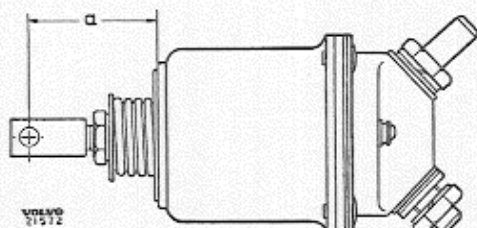


Fig. 30. Adjusting distance for solenoid fork

## Replacing the brushes

If the brushes are damaged or worn down more than halfway, they must be replaced.

When replacing the brushes, the starter motor

should be removed from the vehicle and cleaned externally.

Brushes are replaced with the starter motor assembled. The lead from the brush is disconnected and the brush spring lifted with a hook, after which the brush is removed from its holder. The new brush is slid down into the holder and secured with the screw.

## Replacing the field winding

1. If the starter motor has not been dismantled, this must be done. Follow the instructions under the heading "Dismantling".
2. Mark the pole shoes and pole housing in a suitable manner so that they come in the same position when assembling.
3. Place the stator in the holding device as shown

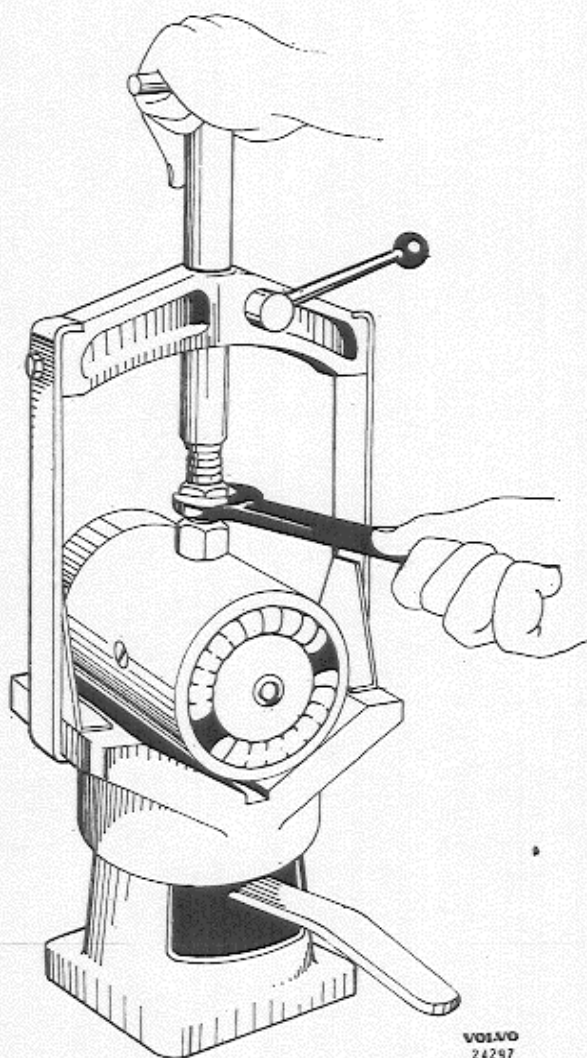


Fig. 31. Holding device for removing the field winding.

in Fig. 31. (Bosch EF AW 9) and unscrew the pole screws.

4. Before fitting new field coils, these should be warmed slightly. Then place the pole shoes in position in the field coils and slide them into the stator. Tighten the pole screws slightly. Press in a suitable drift (for measurements, see Fig. 32). Set up the stator in the holding device and tighten the pole shoes.
5. Press out the drift with a press. Check the field winding fitted for breakage and shorting.

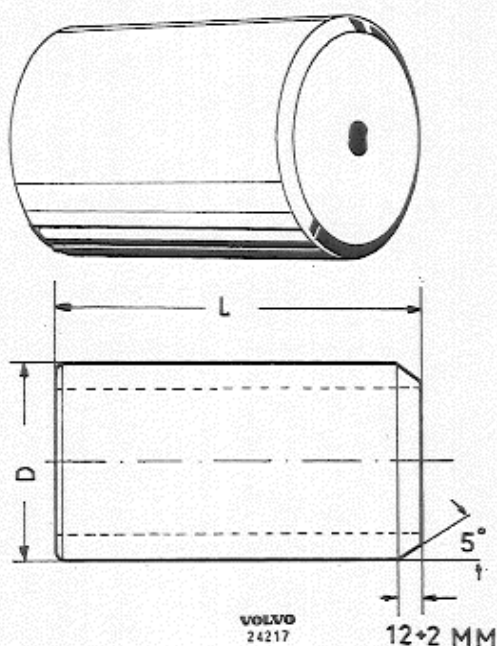


Fig. 32. Press drift (starter motor EGD).

$-0.01$  ( $-0.004$ "")  
 $-0.06$  ( $-0.0023$ "")  
 $D=66.1$  mm (2.602")  
 $L=85$  mm (3.346")

## Fitting the self-lubricating bushings

The self-lubricating bushings are only worn insignificantly during operation if the bushings are lubricated in the correct manner. If lubrication is neglected, the bushings dry out, with the result that they are worn quickly.

For replacement purposes, bushings are supplied ready-machined to suitable dimensions. When being fitted, the bushings should not be machined internally or externally since the pores can then be partially blocked up, resulting in reduced lubricating capacity.

## Replacing the bushings

1. Press, knock or pull out the worn bushing with the help of a suitable tool. Special tools for the brush holder end head are shown in Figs. 33 and 34.
2. Clean the hole for the bushing and cut away any burr.
3. Press in the new bushing with the help of a suitable drift. The guide diameter of the drift

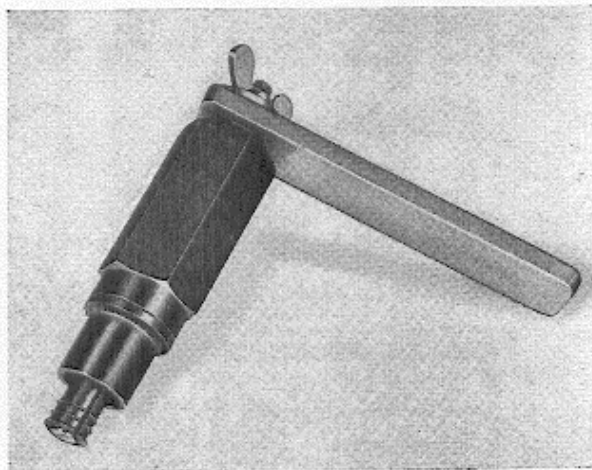
VOLVO  
24528

Fig. 33. Tool for removing bushing.

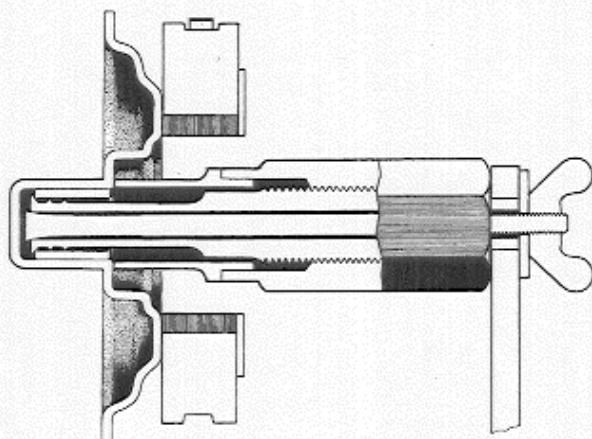
VOLVO  
24455

Fig. 34. Bushing tool fitted in end head.

### Measurement and tolerance table for bushings Starter motor Bosch EGD 1/12 AR 37

	Hole diameter for bushing	Diameter and length for bushing when pressed in.		Tool (Bosch)		
				Puller for bushing	Pressing-in drift	Smoothing drift
Drive bearing	15.8 +0.027	12+0.027	16	—	EFAL 2	EFAL 3
Commutator bearing	16.45+0.018	12.46+0.043	15.8	EFAL 1	EF 2649	EF 2649/1
Starter pinion	14+0.018	12+0.018	12	—	EFAL 2	EFAL 3

## Lubricating scheme for starter motor

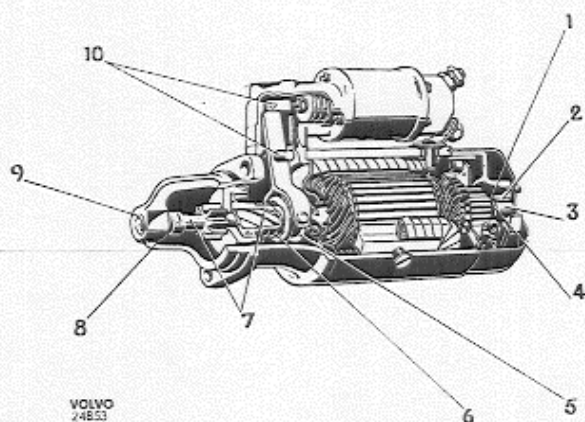
VOLVO  
24653

Fig. 35. Lubricating scheme for starter motor.

10-16

should correspond to the internal diameter of the bushing after it has been pressed in. If necessary, a smoothing drift can be pressed, through the bushing.

Concerning recommendations for bush sizes and drifts, see the table below.

NOTE. Before a self-lubricating bushing is fitted, it should lie in thin oil for at least 30 minutes.

Use Bosch lubricant (or corresponding) in accordance with the following designations:

1. Ft 1 v 8. Grease the rotor brake springs lightly.
2. OL 1 v 13. Place the bushing in oil for 30 minutes before fitting.
3. Ft 1 v 8. Grease the adjusting washers and shaft end lightly.
4. Ft 1 v 8. Apply plenty of grease to the rotor brake.
5. Ft 1 v 8. Apply plenty of grease in the groove.
6. Ft 1 v 8. Grease the flange sleeve and coil spring lightly.
7. Ft 1 v 8. Grease the shaft end and cams lightly.
8. Ft 1 v 8. Grease the adjusting washers lightly.
9. OL 1 v 13. Place the bushing in oil for 30 minutes before fitting.
10. Ft 1 v 8. Grease the pins and their bearing points lightly.

## Testing the starter motor

After the starter motor has been assembled, it should be tested before fitting to the vehicle.

Carry out the mechanical tests first. Measure the friction torque of the rotor brake and the free-wheeling torque of the pinion, together with the brush spring tension and rotor axial clearance if these have not been checked previously. After these tests, the electrical tests should be carried out.

First test the starter motor unloaded against the values given in the specifications. After this test, the starter motor pinion is locked by connecting to a lever which is secured. Read off the voltage and current and compare with the specifications.

## Dynamo

### Removing

1. Remove the cable terminal from the battery negative terminal stud.
2. Disconnect the leads from the dynamo.

3. Disconnect the stay for tensioning the V-belt and lift off the V-belt.
4. Remove the two bolts which hold the dynamo to the engine and lift it off.
5. Wipe off the dynamo externally with a piece of cloth soaked in petrol.

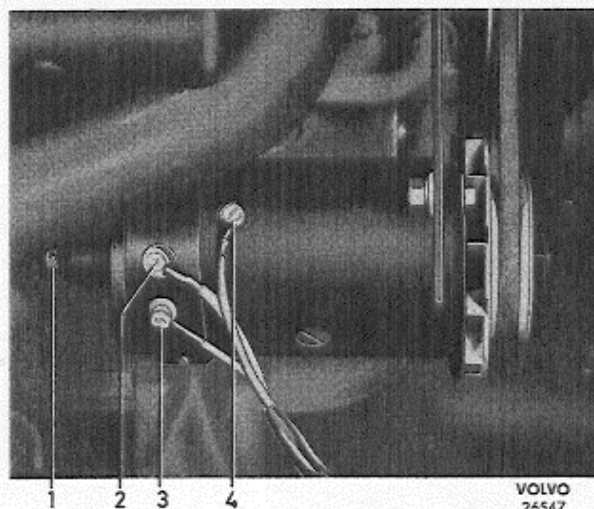


Fig. 36. Dynamo connections.

- |                                               |                     |
|-----------------------------------------------|---------------------|
| 1. Lubricating cup (only on dynamo type AR 6) | 2. Dynamo D+        |
|                                               | 3. Dynamo field, DF |
|                                               | 4. Earth lead       |

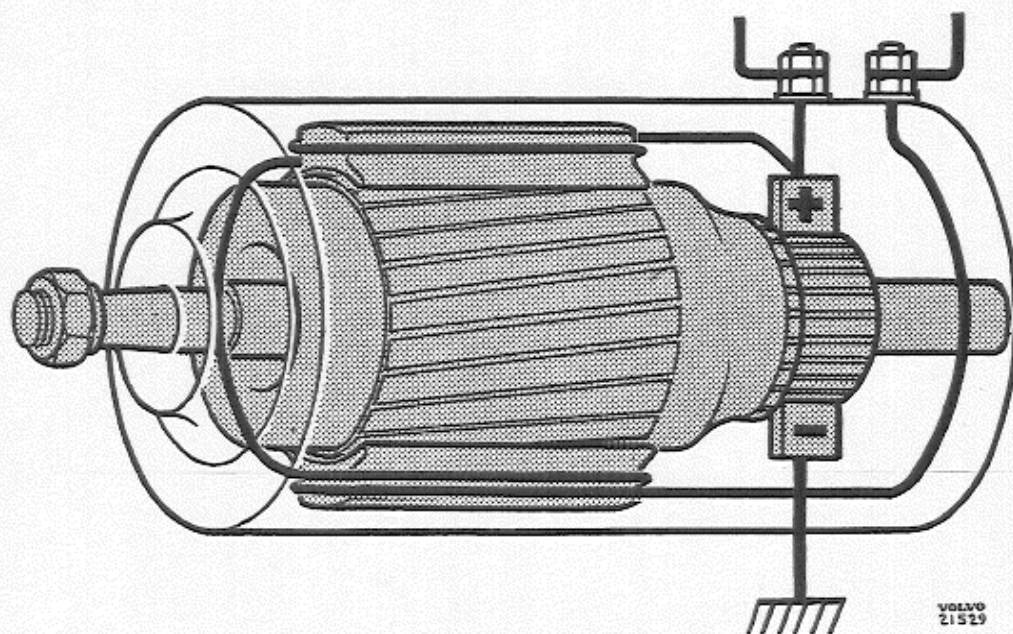


Fig. 37. Dynamo. Principle diagram.

## Measures to be taken before removing and dismantling

If the dynamo does not charge, or if there is reason to suspect that it is not producing sufficient current, or gives off excessive current or voltage, it must be ascertained whether the fault lies in the dynamo itself or if the charging control and leads are out of order.

First check that the connection from the battery to the relay terminal marked 51 B+ is intact. This is done with a voltmeter. The voltmeter is connected between the relay terminal B (51 B+) and the chassis. The voltage here must not be less than the battery voltage. If the voltmeter gives a poor reading, the leads and contact points must be examined. If the voltmeter gives no reading at all, this indicates a breakage in the system.

If there is no fault, the following tests should be carried out on the dynamo. The leads on the dynamo are disconnected. The field terminal (DF) is connected with a lead to the dynamo frame and a voltmeter connected between the dynamo current terminal (D+) and the dynamo frame. The engine is started and the speed increased from idling up to about 2000 r.p.m. during which time the voltage should rise in proportion to the increase in engine speed. Then go back to idling speed and disconnect the earth connection of the field. The voltmeter should then return to 0. If it does not do so, this means that the field is earthed inside the dynamo, causing the charging control to be put out of function with the result that the dynamo will burn out. The test can also be carried out as follows: disconnect the dynamo leads on the charging control. The field lead is earthed and the engine speed gradually increased during which time the other lead from the dynamo is brought into contact with the charging control frame a few times. Heavy sparking should then occur when contact is made between the lead and the charging control frame.

Contact between the charging control frame and field winding should then be broken and the main lead brought into contact with the charging control frame again, when no sparking must occur. If so, this indicates that field is earthed inside the dynamo.

If there is no sparking, or if the voltmeter does not give a reading, this means that the dynamo is faulty and must be removed.

## Examining the dynamo

After removing, the dynamo should be cleaned externally with petrol or similar. The protecting band for the brushes should be removed and the dynamo placed on a test bench. The testing to be carried out now is done to establish the type of fault in the dynamo and it is most important that testing is carried out correctly and with reliable instruments.

The dynamo field terminal is connected to the dynamo frame and this connected to the battery negative terminal. The positive terminal on the battery is connected in series with an ammeter to the dynamo output terminal.

The dynamo should then run as motor at a low, even speed. If not, see the following faulttracing scheme.

Current low, rotor stationary.	Brushes worn or bind in their holders and do not reach down to the commutator.
Current low, rotor rotates slowly.	Poor contact between the brushes and commutator. Breakage in rotor winding.
Current high, rotor stationary.	Shorting in the rotor. Breakage or shorting in field. A bearing has seized.
Current high, rotor rotating.	Scored or burnt commutator. Binding bearings. Excessive brush spring pressure.
Excessive movement of brushes and heavy sparking.	Out-of-round or burnt commutator. Damaged brushes.

## Dismantling

Dismantling the dynamo for overhaul (cleaning and lubricating) is done as follows:

1. Remove the protecting band if this has been re-fitted after testing.
2. Disconnect the brush connecting leads. Lift up the pressure arms or springs for the brushes with a hook and pull up the brushes as shown in Fig. 38.
3. Remove the screws which hold the dynamo housing and end heads together after having first disconnected the connecting bar as shown in Fig. 39.

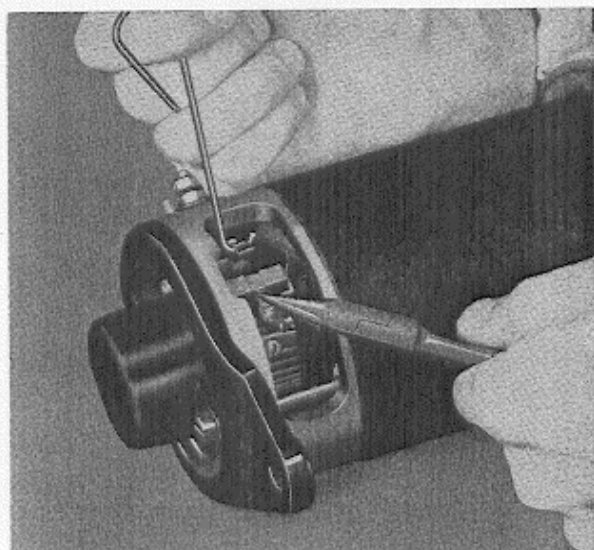


Fig. 38. Removing the brushes.

4. Lift off the rear end head with brush holders.
5. Lift the rotor out of the housing.
6. Place the rotor in a vice but do not tighten too hard (use copper jaws). Unscrew the nuts for the belt pulley and pull this off. Use a suitable tool as shown in Fig. 40. Remove the Woodruff key.
7. Remove the front end head from the rotor.
8. Pull off the ball bearing with a standard puller.
9. Blow the dynamo housing with field winding and rotor clean from dust and dirt. Wipe with

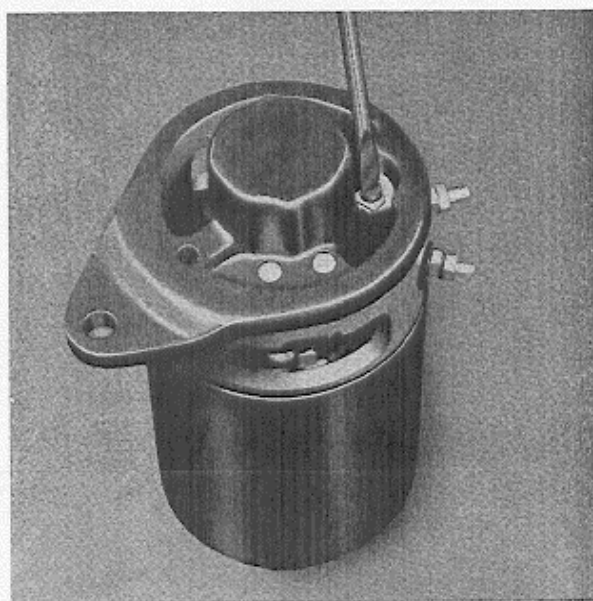


Fig. 39. Removing the connecting bar.

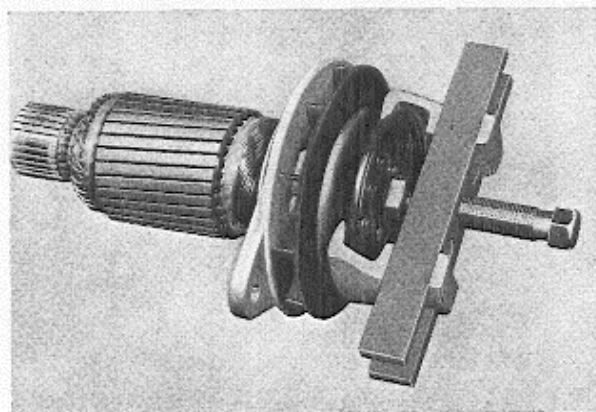


Fig. 40. Removing the belt pulley.

a linen rag soaked in petrol. Note. Spirit mixtures such as bentyl must not be used since these can dissolve the insulation. Wash the other parts, except for the brushes, in clean petrol.

## Inspecting

Examine the rotor for mechanical damage such as bent or worn shaft, scored commutator and damaged or loose rotor winding.

A shaft which is only slightly bent can be straightened in a press, but this is not recommended. It is preferable to replace the rotor.

If the commutator is scored or unevenly worn, it should be turned. When turning, a special chuck should be used. The greatest care must be observed. Take small cuts each time so that no more material than is absolutely necessary is removed. If too large cuts are taken, this can damage the insulation and laminations. Ensure that no object touches the rotor or winding during turning.

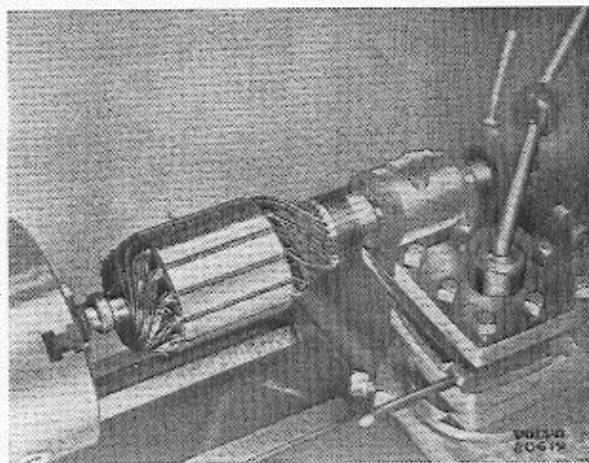


Fig. 41. Turning the commutator.

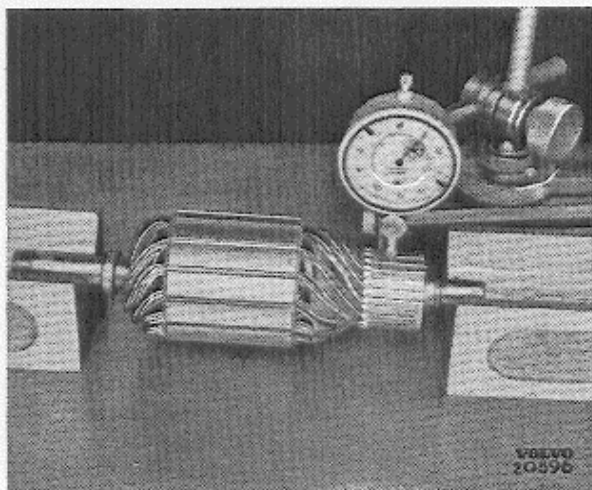


Fig. 42. Measuring the commutator with dial indicator gauge.

After turning, the commutator should be measured with a dial indicator gauge as shown in Fig. 42. A maximum out-of-roundness of 0.013 mm (0.0005") can be considered permissible. The insulation between the laminations should be milled down 0.8—1.0 mm (0.032—0.039") below the surface, see Fig. 43. This is done in a special apparatus, or if one of these is not available with a ground-off hacksaw blade.

Examine the rotor both before and after turning by placing it in a growler. Switch on the current and hold a hacksaw blade close to the rotor, see Fig. 44. If the blade vibrates in any position when the rotor is turned round, one of the following faults can be the reason: shorting to rotor frame, shorting in commutator or windings.

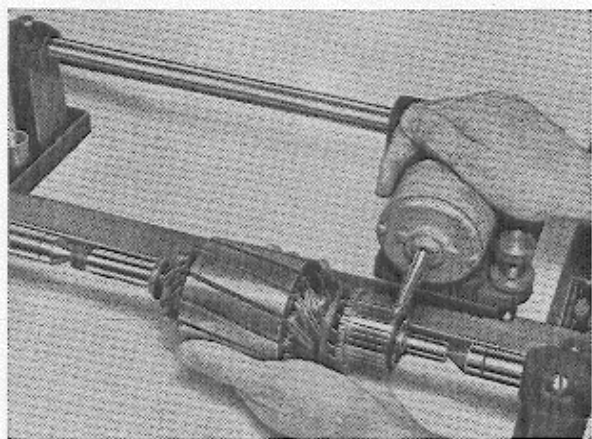


Fig. 43. Milling the grooves.

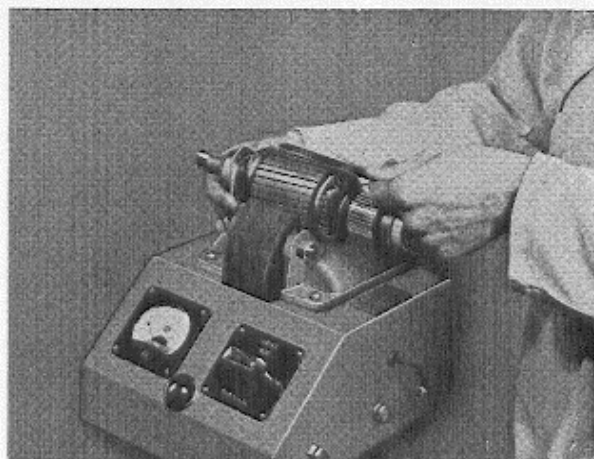


Fig. 44. Testing the rotor.

Shorting between the windings can be determined by holding the resistance prong against the commutator as shown in Fig. 45.

Switch on the current and adjust the rheostat while turning the rotor backwards and forwards, until the highest reading is obtained on the meter. Turn the rotor (the prong must be held still) so that the next pair of laminations comes opposite the prong and hold this against these. If there is no fault, the reading should be the same for all the other laminations. A rotor coil with shorting between the windings shows a low reading and a coil with breakage, no reading at all.

Shorting to the rotor body is tested with the help of test prods and testing lamps as shown in Fig. 46.

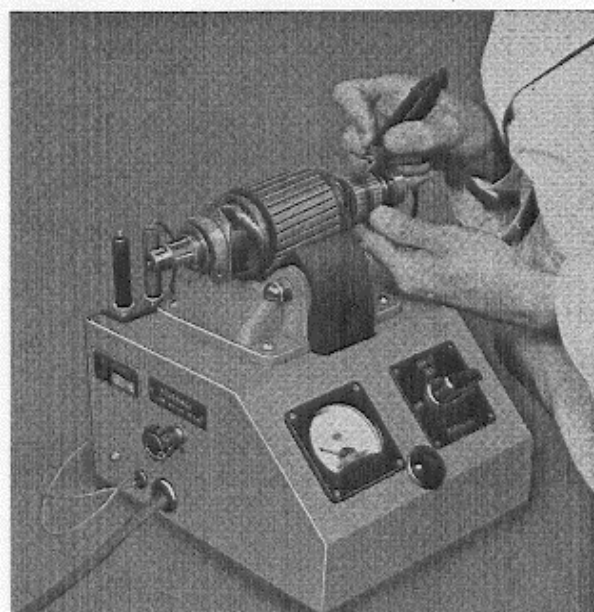


Fig. 45. Measuring the rotor.

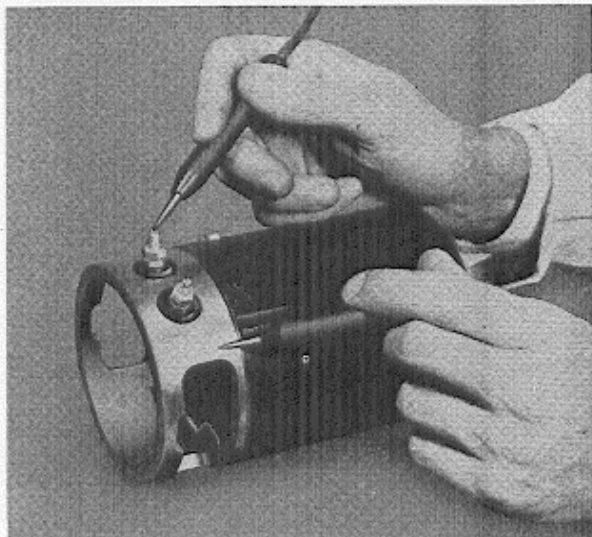


Fig. 46. Testing the stator.

Examine the housing and field winding for any damage which could be caused by the rotor. Test that the field winding is not earthed by connecting the contact points to the field terminal and housing.

If the lamp lights, this indicates shorting between the field winding and housing. Unscrew the field lead-through and test again. If the lamp still lights, this indicates that the field winding is in contact with the housing. The winding must then be removed. Concerning this, see under "Replacing the field winding".

Internal faults in the field coil can be determined by measuring the current consumption of the coils.

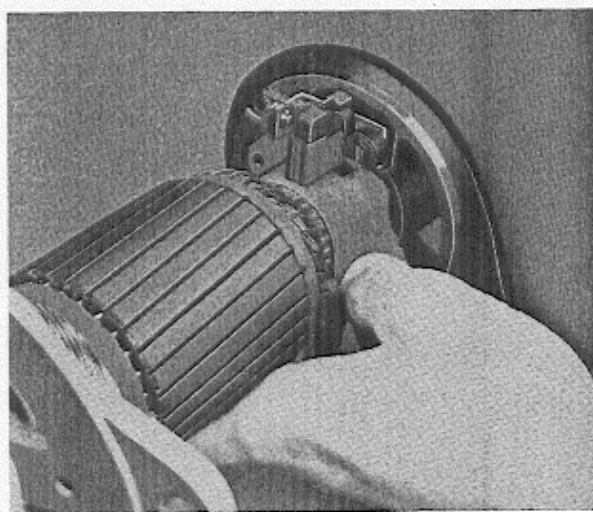


Fig. 47. Grinding-in the brushes.

This is done with an ohmmeter or a volt-ammeter. If the latter instrument is used, conversion must be done in accordance with Ohm's law.

Examine the rear end head with brush holders. If any of the parts are damaged, they must be replaced. Test that there is no shorting between the positive brush holder (insulated) and the end head.

Brushes which are damaged or worn down more than halfway must be replaced. Brushes which are scored or have poor contact with the commutator can be ground-in with sand paper gauge 00 or 000 as shown in Fig. 47. Test the strength of the brush springs by fitting the end head on the rotor and connecting a spring balance to the movable arm or spring, see Fig. 48. The force necessary to lift the arm or spring should agree with the values given in the specifications. If there is any deviation, the spring must be replaced.

Check the bearings. The ball bearings should rotate easily without any noticeable play. Damaged or worn bearings must be replaced.

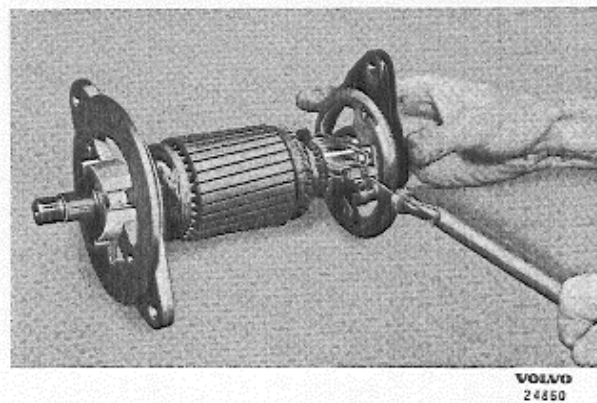


Fig. 48. Measuring the brush pressure.

## Assembling

1. Fit the stop ring and sleeve, if there is one, on the shaft.
2. Place the inner cover with any felt ring on the shaft. Lubricate the bearing with heat-resistant ball bearing grease and then fit it.
3. Place the front end head on the shaft and bearing and screw together the end head and cover.
4. Drive in the cross-key and press on the belt pulley. Place the rotor in a vice. Do not tighten too hard as otherwise the rotor can be deformed. Fit the spring washer and nut.
5. Place the rotor in the housing and ensure that the guide peg comes in the right position.

- Place the end head on the shaft, adjust in the guide peg, and screw in the two screws which hold the dynamo housing and end heads together. Check that the rotor turns easily. Fit the brushes to the holders in the rear end head.
- Connect the bar for the main current to the positive brush, see Fig. 39.

## Replacing the brushes

If the brushes are damaged or worn down more than halfway, they must be replaced. This can usually be determined by the fact that the dynamo ceases to charge. Remove the protecting band and inspect the brushes and commutator. If it is seen that the above-mentioned fault can be the reason for no charging, the dynamo should be removed.

Carefully wash or wipe the dynamo externally with a piece of cloth soaked in petrol.

Take out the brushes by removing the connection at the brush holder, lifting up the brush spring and pulling out the brush with a pair of pliers as shown in Fig. 38. If the commutator is scored or unevenly worn, the dynamo must be dismantled and the commutator turned. Concerning this, see under "Dismantling, inspecting and assembling". Place in the brushes, ensuring that the correct types are used, and fit the protecting band. If there are dynamo testing devices available, it is advisable to test the dynamo before re-fitting it into the vehicle. Concerning this, see under "Testing the dynamo".

## Replacing the field winding

(Alternative to the method described on page 15)

- If the dynamo is not dismantled, proceed in accordance with points 1 to 5 under the heading "Dismantling".
- Place the dynamo housing in a V-block as shown in Fig. 49. Press down at the same time as turning the wrench. As a rule, the screws are tightened very hard. Therefore ensure that the screwdriver head fits well into the slot in the screw and is sufficiently wide.
- When both the screws have been slackeden, the housing is lifted off. Screw out the screws with an ordinary screwdriver. Remove the cable lead-through in the housing and lift out the windings and pole shoes.

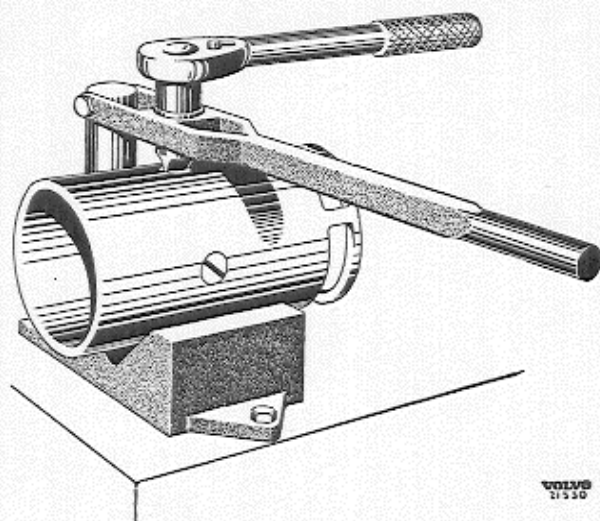


Fig. 49. Removing the field winding.

- Fit the new field winding in the housing. Use the same device for tightening the screws.
- Connect the cables at the lead-through in the housing. Test for earthing.
- Assemble the other parts of the dynamo. See under the heading "Assembling".

## Testing the dynamo

Before the dynamo is re-fitted into the vehicle, it should be tested. Place the dynamo on the test bench and connect the volt-ammeter.

First run the dynamo as motor for a short while. Ensure that the dynamo has the correct polarity negative to frame. Make sure that the current consumption of the dynamo is normal and that it runs evenly and quietly. Then start the drive motor, check its direction of rotation and ensure that the dynamo produces the necessary voltage at the speeds mentioned in the specifications. Check that there is no sparking on the commutator and that the brushes do not jump.

## Lubricating instructions

### Dynamos with ball bearings at both ends

The ball bearings should be cleaned with white spirit and lubricated with ball bearing grease. See the dynamo lubricating scheme, Fig. 50.

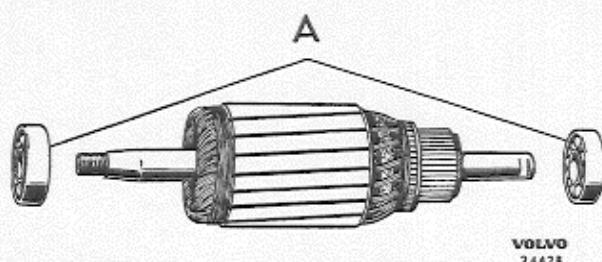


Fig. 50. Dynamo lubricating scheme

A Bearings lubricated with grease, Bosch Ft 1 v 22 or corresponding.

## Dynamos with ball bearing and bushing

For the ball bearing, see above.

**Bushing:** The lubricating cup on the commutator end of the dynamo should be filled with engine oil every 10,000 km (6,000 miles). Lubricating is done with an ordinary oil can. A pressure oil can must not be used.

**NOTE.** A new bushing should lie in an oil bath for at least half an hour before being fitted.

## Charging control Removing

1. Disconnect the leads on the charging control.
2. Remove the charging control from the bulk-head.
3. Wipe off the charging control externally.

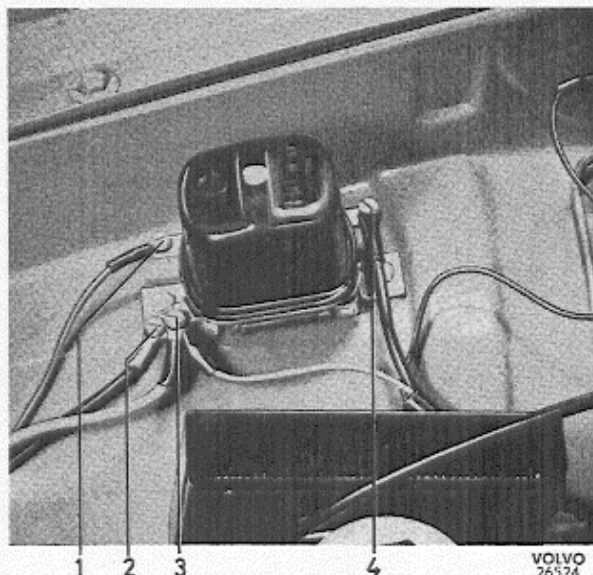


Fig. 51. Charging control terminals.

- |                    |               |
|--------------------|---------------|
| 1. Dynamo field DF | 3. Dynamo D+  |
| 2. Earth lead      | 4. Battery B+ |

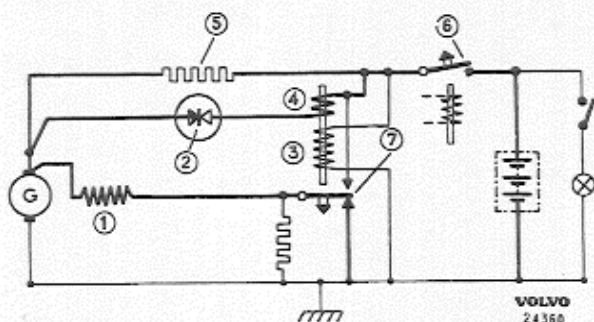


Fig. 52. Wiring diagram for charging control.

- |                    |                        |
|--------------------|------------------------|
| 1. Field winding   | 5. Variode resistance  |
| 2. Variode         | 6. Cut-in contacts     |
| 3. Voltage winding | 7. Regulating contacts |
| 4. Current winding |                        |

## Fitting

1. If the charging control has to be replaced, check that the new one is of the correct type.
2. Screw the charging control onto the wheel housing.
3. Connect the leads as shown in Fig. 51.

## Adjusting the charging control Reverse current relay

### Cut-in voltage

A voltmeter is connected over D+ on the charging control and dynamo frame. The engine is started and the speed increased while watching the voltmeter.

The reading should first increase and then fall back to 0.1—0.2 V, when the reverse current relay cuts in, after which it should remain still. The reading given by the voltmeter up to the point when cutting-in takes place is known as the cut-in voltage.

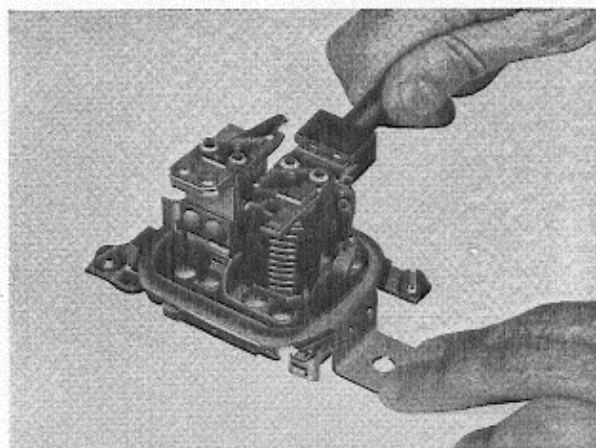


Fig. 53. Adjusting the cut-in voltage.

This should be compared with the value given in the specifications and any necessary adjustment carried out.

Adjusting is done by increasing or decreasing the pressure of the spring which influences the relay armature. If the spring pressure is reduced, the cut-in voltage will decrease and vice versa.

Rough adjusting is carried out as shown in Fig. 53, and fine adjusting as shown in Fig. 54.

#### Reverse current.

An ammeter is connected in series with B+ on the charging control and the lead to the battery. The speed of the dynamo is increased until the ammeter shows a reading. The speed is then reduced gradually. The ammeter needle will go down to zero and then over to discharge. After this, it will suddenly go up again to zero. The reverse current is read off at the turning point of the needle before it returns to the zero position. The relay has cut out when the needle returns to the zero position. The reverse current should lie between the values given in the specifications.

If the reverse current is too low, the bend of the contact spring should be lessened by bending the contact yoke of the cut-in contact. It may be necessary to file off the pole pin slightly. If the reverse current is too high, the bending of the contact spring must be increased. Check the cut-in contact gap and adjust this if necessary. After any adjusting, check the cut-in voltage again.

#### Voltage control

Disconnect the connection B+ on the charging control. Connect a voltmeter between B+ and the

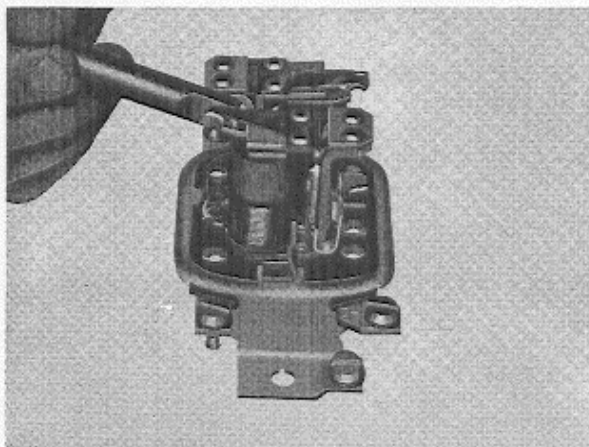


Fig. 54. Fine adjusting the voltage control.

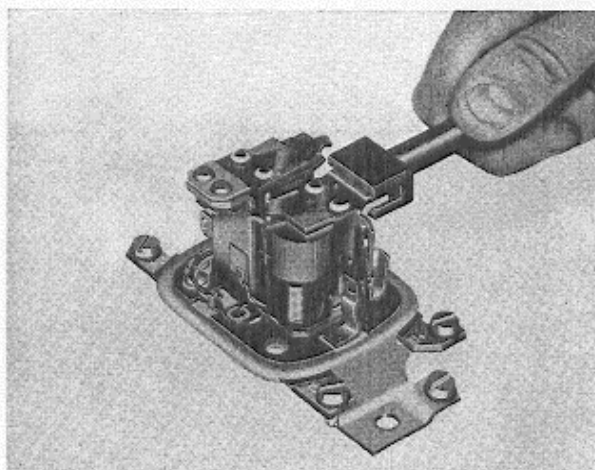


Fig. 55. Rough adjusting the voltage control.

charging control frame and increase the dynamo speed gradually.

As soon as voltage control has begun, that is to say, when the voltage does not increase further, the control voltage should be read off. The control is adjusted by bending the support lip for the spring tongue as shown in Fig. 54, so that the spring tongue is completely unloaded. After this, a rough adjustment is made by bending the relay angle piece as shown in Fig. 55. If the angle piece is bent downwards, the voltage is increased and vice versa. Rough adjustment should lie about 1—2 V lower than final adjustment. This is done by bending the support lip upwards so that the spring tongue is tensioned, see Fig. 55. Use special tool V 397 (Robert Bosch, Stockholm).

Increase and decrease the speed a few times and ensure that the control is correctly adjusted.

NOTE. This adjustment must be done after the dynamo has reached full operating temperature, that is to say, at least 12 minutes after the engine has been started from cold.

#### Checking the variode under loading (cold dynamo)

Connect an ammeter between B+ and the live lead, and connect an adjustable loading resistance of suitable size between the battery side of the ammeter and the frame. In addition, a voltmeter should be connected between B+ and frame.

Increase the speed and note the meter readings. Adjust the loading resistance so that a loading cur-

rent = 1 max. is obtained. Check the control voltage under loading.

Run the engine at the above loading. After about 2—3 minutes the current value must not be higher than 2/3 of the max. current stamped on the dynamo (1 max.) If the loading does not fall, this indicates a fault in the variode, so that the charging control must be replaced.

Since the effect of the dynamo is very high, great demands are placed on the condition and tension of the drive belt. Before carrying out any work on the charging control and dynamo, therefore, always check that the belt is correctly tensioned.

## Distributor

### Removing

1. Lift off the distributor cap.
2. Mark the position of the rotor arm on the distributor housing.
3. Disconnect the primary lead 1, Fig. 56.
4. Disconnect the hose on the vacuum regulator.
5. Unscrew the bolt 6, Fig. 56 and lift up the distributor.

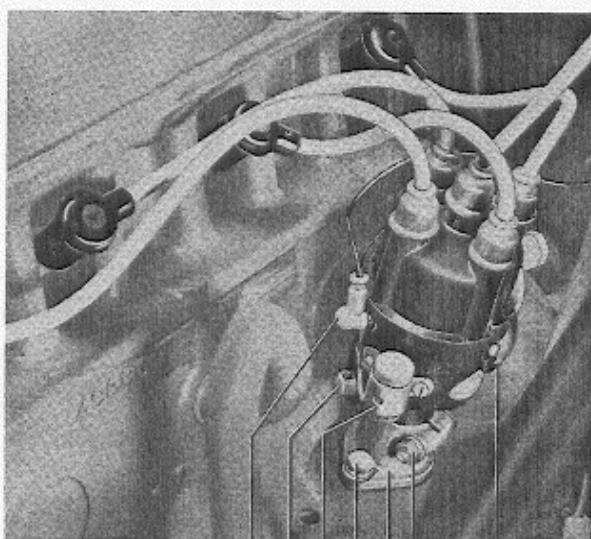


Fig. 56. Distributor fitted.

VOLVO  
26536

- |                                   |                          |
|-----------------------------------|--------------------------|
| 1. Lead for coil                  | 5. Flange                |
| 2. Lubricating cup                | 6. Clamping bolt         |
| 3. Capacitor                      | 7. Clamping catch or cap |
| 4. Attaching bolt for distributor |                          |

### Fitting

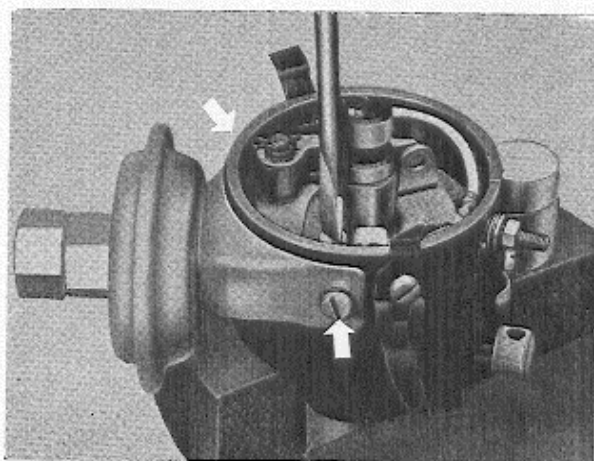
Fitting is done in the reverse order to removing. If the engine has not been moved while the distributor has been removed, fit the distributor in accordance with the marking made under point 2 above.

## Adjusting the ignition

Concerning the adjusting of the ignition, see Part 1, Engine.

## Dismantling the distributor

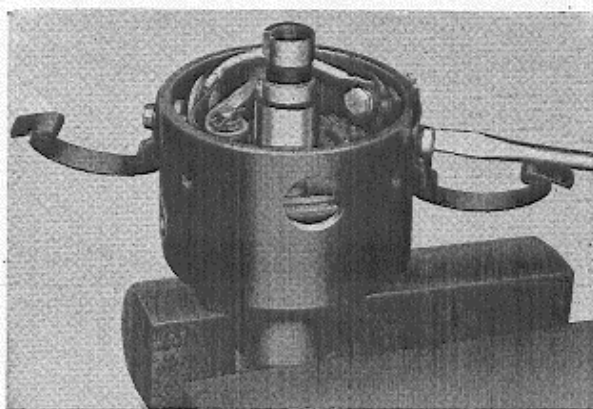
1. Pull off the rotor arm.
2. Disconnect the vacuum regulator by unscrewing the screws as shown in Fig. 57 and then lifting it off.



VOLVO  
24871

Fig. 57. Removing the vacuum regulator.

3. Unscrew the primary terminal screw and remove the washers belonging to it.
4. Remove the breaker plate. This is done by unscrewing the two screws which hold the catch springs for the cap, see Fig. 58.



VOLVO  
74849

Fig. 58. Removing the breaker plate.

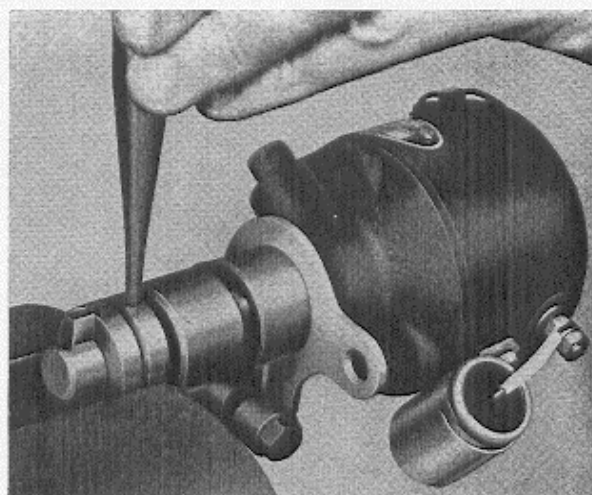
VOLVO  
24870

Fig. 59. Removing the flange.

5. Lift off the stop spring (locking spring) and knock out the pin for the flange and pull this off. Mark the position of the flange in relation to the shaft, see Fig. 59.
6. Lift up the distributor shaft.
7. Remove the locking springs and springs between the centrifugal governor and contact breaker camshaft and lift this up.
8. Wash all parts in petrol or white spirit and lay them out for inspection.

## Inspecting

### Distributor plate

1. The surface of the contact should be flat and smooth. The colour of the contacts should be grey. Oxidized or burnt contacts must be replaced. After a long period of use, the contact lip can be worn and the spring fatigued, so that the contact should be replaced.
2. The contact plate must not be loose or worn so that there is any burr.

### Distributor shaft

1. The play between the distributor shaft and the breaker camshaft must not exceed 0.1 mm (0.004").
2. The cams on the breaker camshaft must not be scored or worn down so that the closing angle is altered.

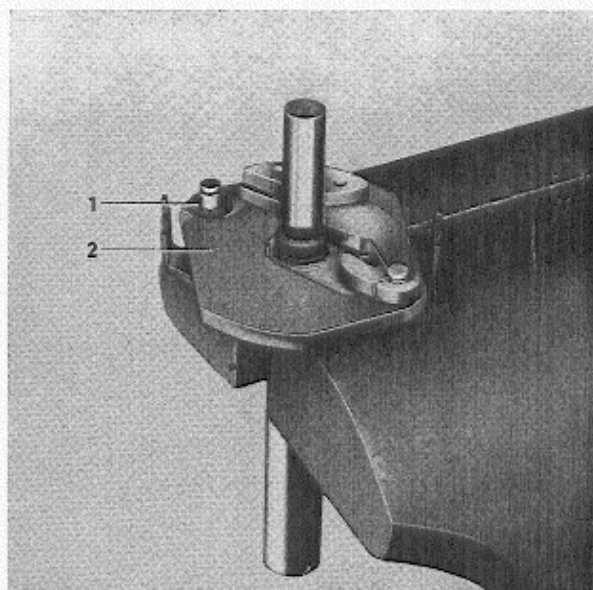
VOLVO  
24872

Fig. 60. Flange with fibre washers.

1. Fibre washer
2. Resitex plate

3. The holes in the centrifugal governor weights must not be oval or deformed in any other way. The fibre washers, see Fig. 60, must be intact.
4. The governor springs must not be deformed or damaged.

## Distributor housing

1. The clearance between the distributor housing and shaft should not exceed 0.2 mm (0.008"). In the event of excessive play, the bushings must be replaced and, if this is not sufficient, the shaft also.
2. The insulation washers for the primary terminal must not be cracked or soaked in oil, as this will cause leakage over the primary terminal.
3. The capacitor is tested with a glow lamp connected to direct current, or with a capacity bridge.

When testing with a glow lamp at room temperature, there must be no discharging. When testing with warm capacitor (60—70°C = 140—158°F), up to 15 discharges per minute can be accepted.

## Assembling

1. Place the Resitex washer on the distributor shaft and the fibre washers above this, see Fig. 60. Lubricate and place the centrifugal gover-

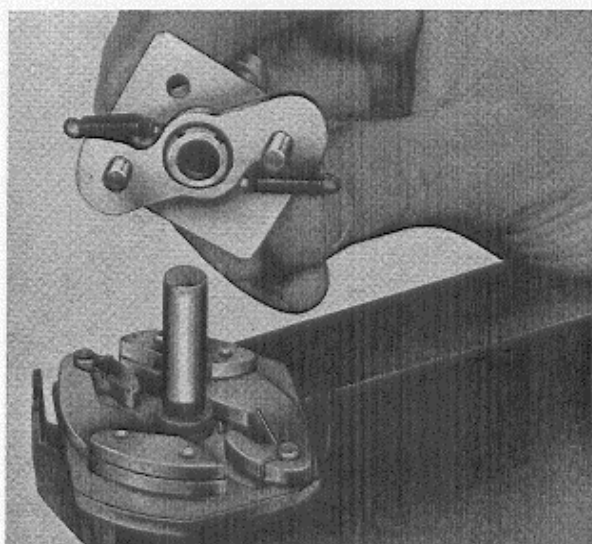
VOLVO  
24858

Fig. 61. Fitting the breaker camshaft.

nor weights in position. Place on the locking springs. Concerning lubrication, see Fig. 64.

- Lubricate and fit the breaker camshaft and place on the springs, see Fig. 61.
- Lubricate the distributor shaft and place it in the distributor housing. Check that the axial adjusting washers are positioned correctly. The fibre washer should contact the inside of the distributor housing. The steel washers should contact the flange.

Fit the breaker plate and distributor cap catch springs, see Fig. 62.

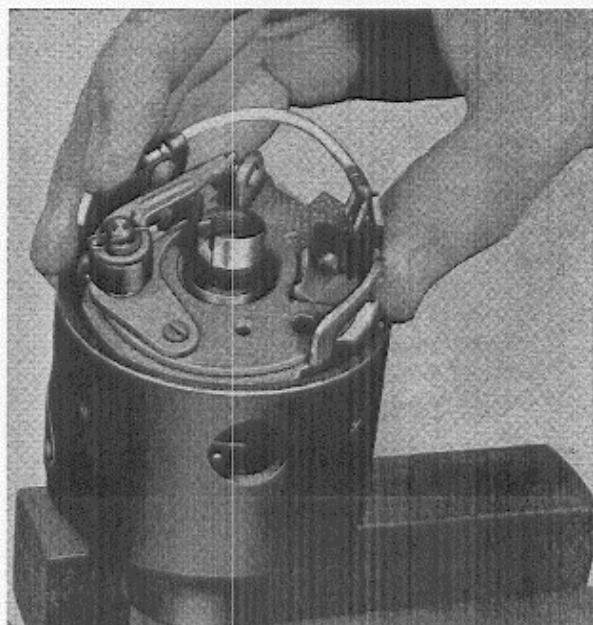
VOLVO  
24858

Fig. 62. Fitting the breaker plate.

- Fit the primary terminal and connect this to the breakers and capacitor.
- If the contacts have been replaced, ensure that the new ones lie correctly horizontally and that their faces close flush against each other. Adjustment can be made with a special tool, for example, Bosch EFAW 57 or similar. Only the fixed contact may be bent as shown in Fig. 63. Adjust the gap and check the contact pressure.
- Fit the vacuum regulator.
- Fit the flange and check the axial play. The fibre washer should lie against the distributor housing and the steel washer or washers against the flange. The axial play must be min. 0.1 mm (0.004"), max. 0.2 mm (0.008").

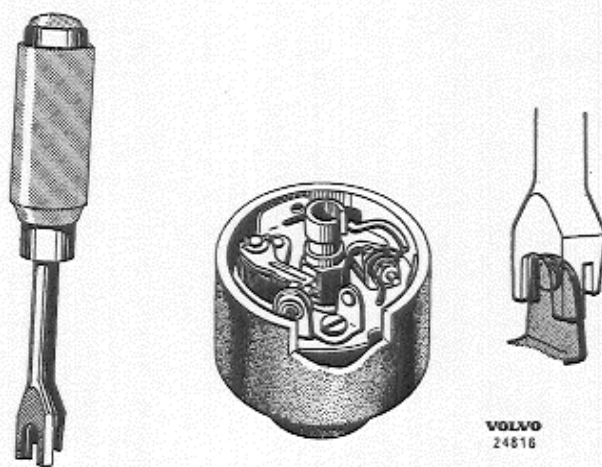
VOLVO  
24816

Fig. 63. Adjusting the contacts.

## Testing the distributor

The distributor should be tested in a synchronograph or in a test bench equipped with the necessary appliances.

- Secure the distributor in accordance with the instructions applying for the test bench concerned.
- Run the distributor in the normal direction or rotation and set the contact closing angle in accordance with the specifications.
- Run the distributor and set the graduated disc so that sparking occurs opposite  $0^\circ$  when the speed is so low that the centrifugal governor has not begun to function. Increase the speed gradually and read off the values at the prescribed revolutions. A newly lubricated distributor should first be run up to maximum speed a few times. Permissible tolerance for the centrifugal governor is  $\pm 1^\circ$ .

4. Run the distributor at low speed (about 200 r.p.m.) and set the graduated disc so that sparking is obtained at  $0^\circ$ .

Increase the vacuum and read off the ignition adjustment. Increase the vacuum successively and check that the whole adjustment range agrees. Then test the vacuum regulator in a falling direction by lowering the vacuum and reading off the values. The differences between the rising and falling values should not exceed  $1\frac{1}{2}^\circ$ . If so, there is a fault in the breaker plate, pull rod or vacuum regulator.

### Adjusting the ignition control curve (centrifugal regulator)

Adjusting the curve is done by tensioning the centrifugal regulator springs. When doing this the shaft must be lifted up from the distributor housing and the screws on the other side of the flange slackened. If the flange is turned opposite to the direction of rotation, the springs are tensioned; that is

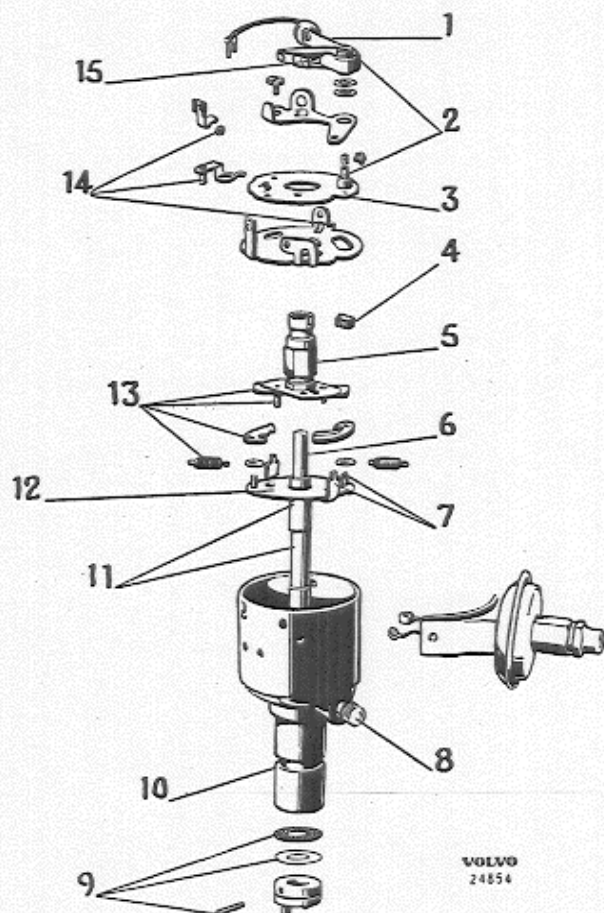


Fig. 64. Lubricating scheme for distributor. (Lubricant Bosch or corresponding).

to say, ignition is lowered and maximum control is reached later.

NOTE. Adjusting the curve must not be done by bending the flange spring loops.

## Headlights

### Replacing the headlights

The following section describes the procedure for removing the headlights from the car and dismantling them completely. In the case partial dismantling proceed in accordance with the appropriate points.

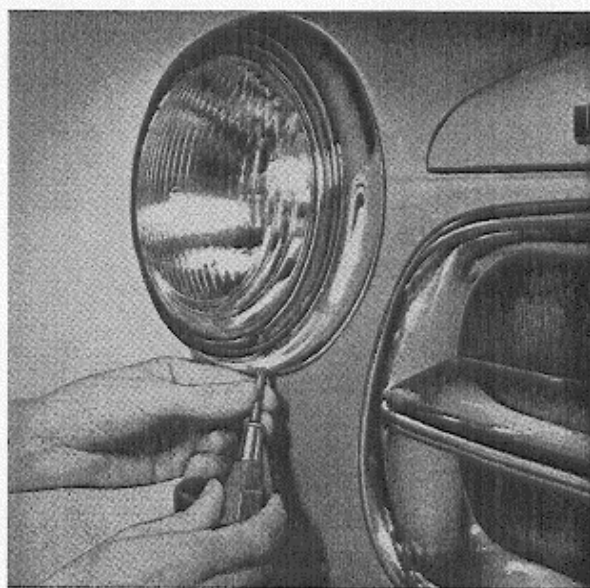


Fig. 65. Removing the headlight rim.

1. Grease the spring lightly Ft 1 v 4
2. Grease the bushing and bearing pin Ft 1 v 22
3. Oil the breaker plate sliding surfaces Ol 1 v 2
4. Soak the lubricating wick with oil Ol 1 v 2
5. Coat a thin layer of grease on the cam surface Ft 1 v 4
6. Grease the end of the shaft lightly and oil with Ft 1 v 8 and Ol 1 v 2.
7. Grease the bearing pins and spring attachments Ft 1 v 8
8. Fill the oil cup while turning the shaft Ol 1 v 13
9. Oil the washers and pin before fitting Ol 1 v 13
10. Soak the lubricating wick between the bushings with oil Ol 1 v 13
11. Lubricate the shaft and fibre washers with grease and oil Ft 1 v 22 and Ol 1 v 13
12. Oil the regulator plate Ol 1 v 22
13. Lightly coat the contact surfaces, flange pins, etc. Ft 1 v 8
14. Lubricate the bearing pin, ball, guide lip and contact surfaces with plenty of grease Ft 1 v 22
15. Apply a little grease to the rivet side of the lifting lip Ft 1 v 4

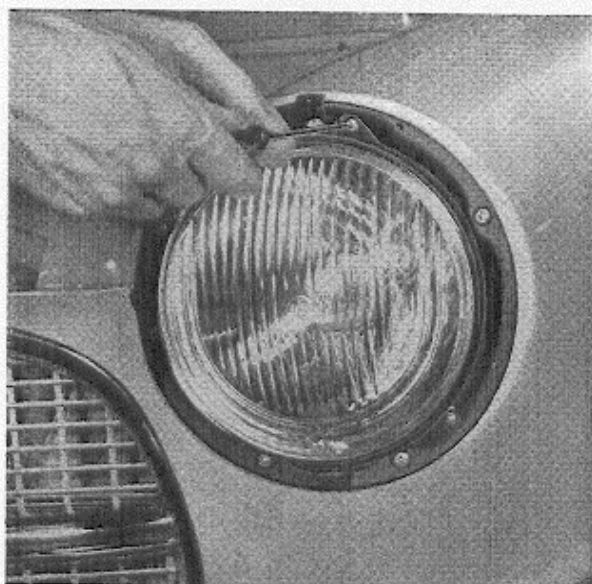


Fig. 66. Removing the retaining ring.

1. Unscrew the headlight rim screw, see Fig. 65. Lift off the rim by pulling out the lower part slightly and then lifting it upwards.
2. Slacken the screws for the headlight insert retaining ring a few turns, see Fig. 66. Turn the retainer until the lips are free of the screws and lift out the retainer and insert with bulb holder.
3. Remove the connecting contact from the bulb holder by pulling it straight out as shown in Fig. 67.



Fig. 67. Removing the connecting contact.

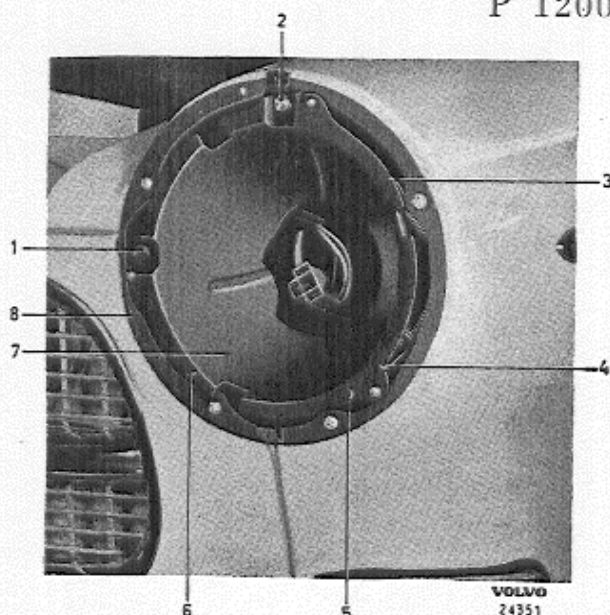


Fig. 68. Headlight bowl.

4. Slacken the screws (1 and 2, Fig. 68) for the headlight adjustment 8—10 turns. Unhook the springs (3—6) from the bowl (7) lift out the bowl from the casing (8).
5. Remove the springs and adjusting screws from the casing.
6. Remove the casing from the mudguard and pull out the cable and rubber bushing.
7. Fitting is done in the reverse order. Ensure that the leads are correctly connected and that the screws are tightened properly.

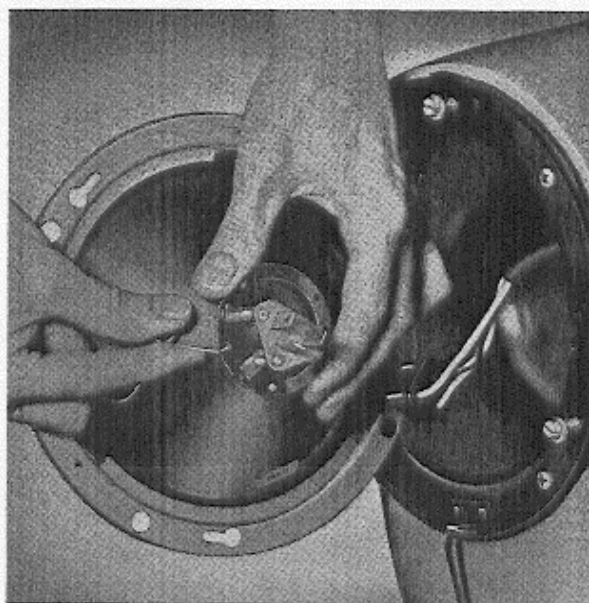


Fig. 69. Removing the bulb holder spring.

## Replacing the bulbs

1. Carry out operations 1—3 under the heading "Replacing the headlights".
2. Lift off the spring (springs) as shown in Fig. 69. The spring (springs) secure the bulb holder in the case of symmetrical headlights and the bulb in the case of asymmetrical headlights.

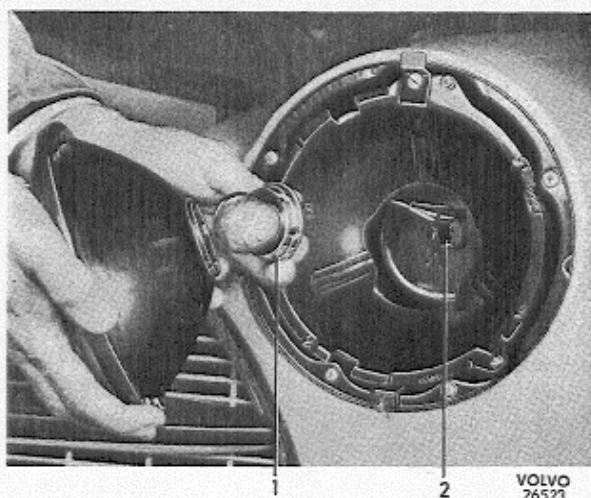


Fig. 70. Fitting the bulb.  
(asymmetrical light).

1. Bulb
2. Connecting contact

3. Fit the new bulb. For asymmetrical headlights, this is done as shown in Fig. 70. For symmetrical inserts, the bulb is placed directly into the insert, after which the springs are hooked on.

Do not touch the actual bulb glass with the fingers.

4. Fitting is done in the reverse order to removing.

## Adjusting the headlights

From a traffic safety point of view it is of the utmost importance that the headlights are adjusted to conform with current regulations.

Adjusting is done by turning the screws 1 and 2, Fig. 68.

## General

The headlights should be examined to check the condition of the glass, reflector and bulb. If the glass is cracked or damaged in any other way, the insert should be replaced.

Glass which has become "sand-blasted" by stone impact, etc., will considerably reduce the lighting effect and can give rise to dazzling, irregular beams.

If the reflector is rusty, dull, buckled or damaged in any other way, the insert should be replaced.

The inside of the bulb must not be oxidized to a black or brown colour. The lighting effect normally deteriorates to such an extent that the bulbs should be replaced after 100—200 hours use.

The voltage at the bulb with headlights switched on and the engine running at charging speed, should be at least 12.5 V in order to produce sufficient lighting strength.

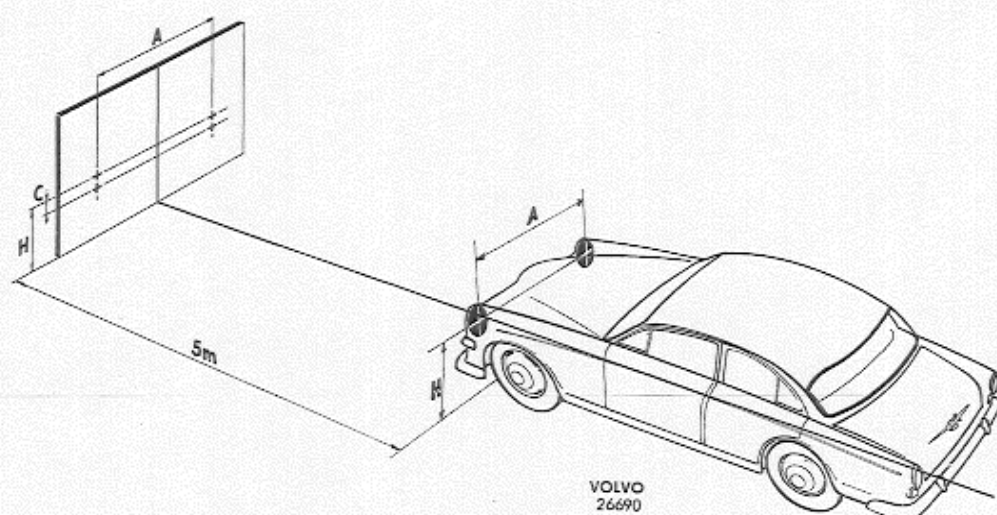


Fig. 71. Headlight adjustment.  
C = 5 cm (2")

## Adjusting

For lighting strength, the following applies:

Concerning full headlights, the lighting strength from each headlight measured 15 cm (6") above the road surface at a distance of 100 metres (109 yards), should be at least 1 lux.

With dipped headlights, no dazzling beams must be emitted above a horizontal plane through the centre line of the headlights. For dipped headlights, the lighting strength measured at a distance of 25 metres (27 yards) must not exceed 1 lux above the horizontal plane through the headlight centre.

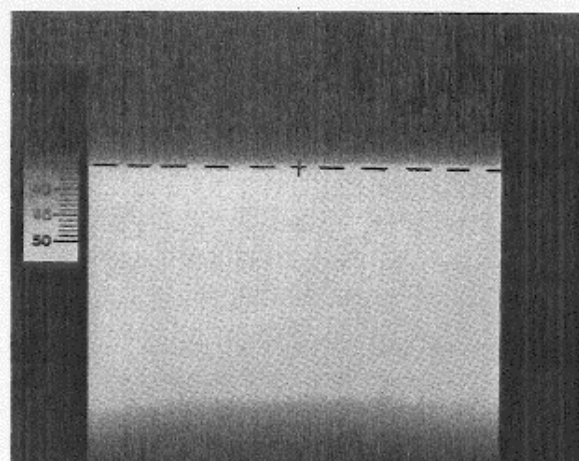
Adjustment can be done either on the level floor against a screen or wall, or with one of the approved lighting adjustment devices on the market. If one of these is used, follow the directions issued with it.

### Height adjustment on a level floor against a wall or screen

1. The vehicle must be stood on a *level* base.
2. A screen should be set up 5 metres (16 feet) in front of the radiator and crosses marked out on the screen. The position of the crosses in relation to the ground, and the distance between, them should be identical with the corresponding measurement at the centre point of the lamps.
3. According to regulations, the horizontal limiting line between the illuminated and non-illuminated surface on the screen should be situated 5 cm (2") below the connecting line between the above-mentioned crosses.
4. The defraction point between the horizontal limiting line and the inclined limiting line between the illuminated and non-illuminated surface, should fall vertically below the above-mentioned cross markings respectively. (Asymmetrical lighting).

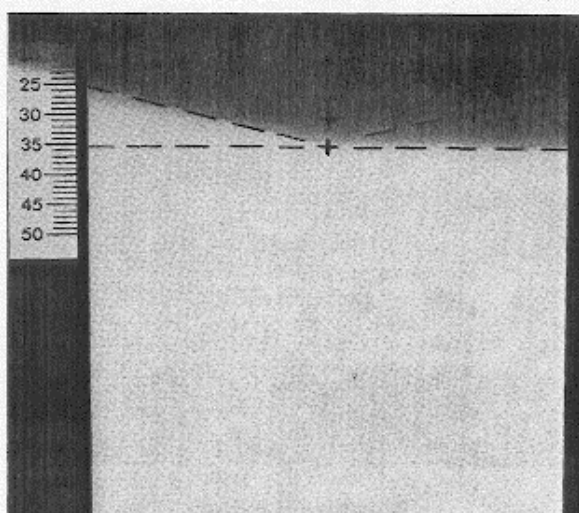
As can be seen from the above, it is only necessary to check dipped headlights in order to carry out headlight adjusting.

The light pictures with symmetrical and asymmetrical lighting respectively should appear as shown in Fig. 72. For asymmetrical lighting, a sharp horizontal light — the darkness limit — only to the right of the centre cross is a sign that the dipped headlight adjustment is good both from a sight and anti-dazzle point of view.



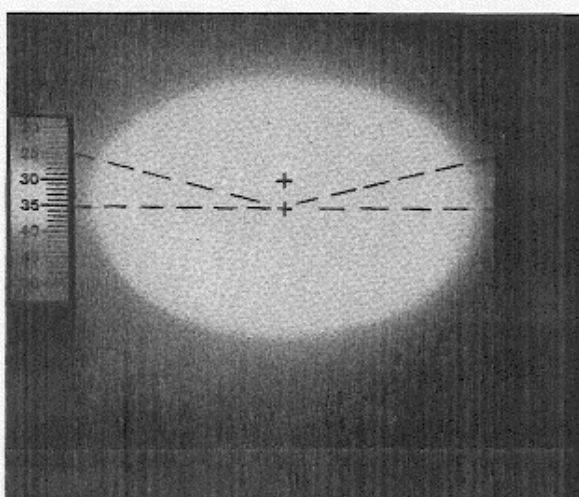
a. Symmetrical dipped headlights

VOLVO  
26718



b. Asymmetrical dipped headlights

VOLVO  
26717



c. Full headlights

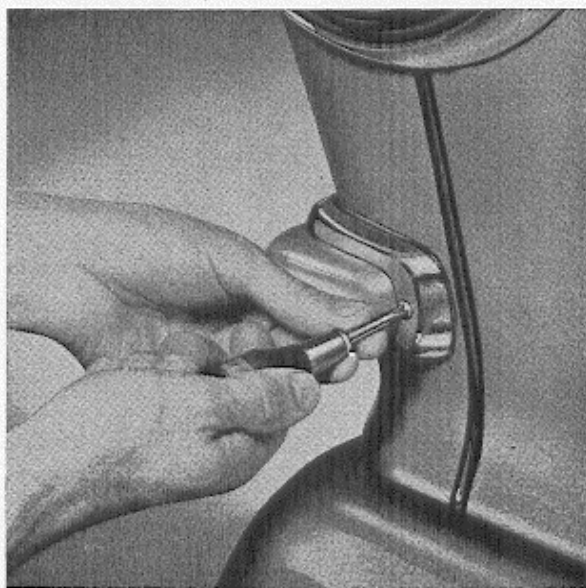
VOLVO  
26719

Fig. 72.

Light pictures from a Bosch headlight adjusting instrument.

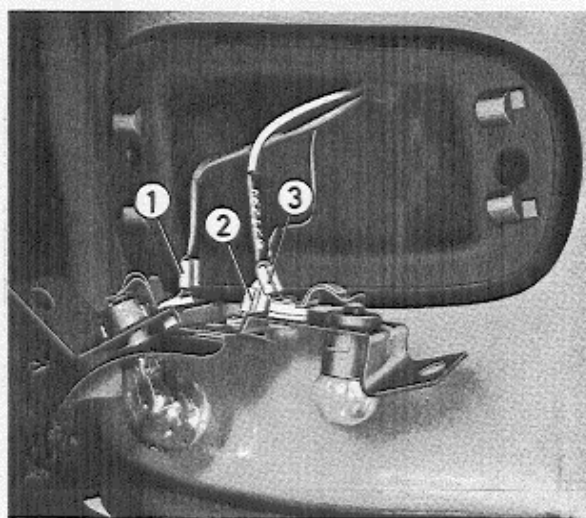
## Flashers and parking lamps

1. The glass is removed by unscrewing the two screws in the rim, see Fig. 73.
2. Then unscrew the screw which holds the insert and pull this out.
3. The respective bulbs are now accessible for replacement. Use the bulb carton as a protection for the bulb when fitting it.



VOLVO  
23225

Fig. 73. Removing the parking lamp rim.



VOLVO  
26549

Fig. 74. Parking lamp dismantled.

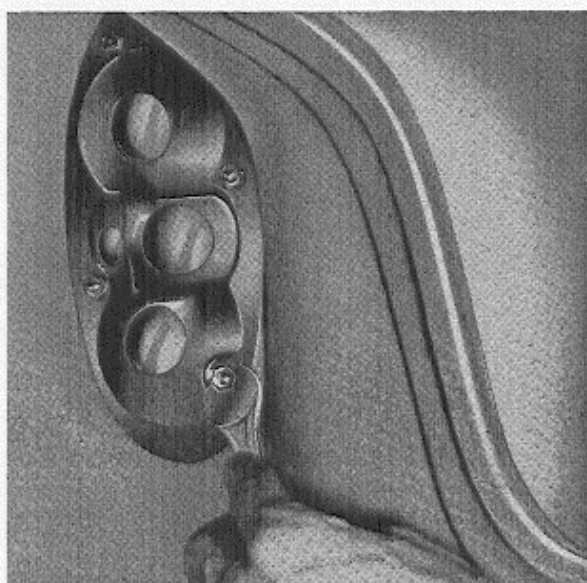
1. Direction indicator
2. Earth lead
3. Parking light

## Rear lamp

### Replacing the rear lamp (glass)

1. Unscrew the four nuts from inside the luggage compartment, see Fig. 75.
2. Then pull the reflector inwards in the luggage compartment and the glass outwards.

Fitting is done in the reverse order. When doing so, ensure that the rubber gasket seals properly against the mudguard and that the toothed washers are placed between the reflector and mudguard. Without these, the bulbs will have no or poor earthing contact.



VOLVO  
23226

Fig. 75. Dismantling the rear lamp (bulbs removed)

### Replacing the bulbs

The bulbs are accessible for replacement from inside the luggage compartment. The bulb holder is removed by prising over to one side, see Fig. 76. When fitting, use the carton so that the bulb glass is not touched with the fingers.

## Number plate lamp

### Replacing the number plate lamp

The number plate lamp is accessible for replacement from the underside of the luggage compartment, see Fig. 77.

The bulb with bulb holder is removed by pressing in the spring and pulling the holder out.

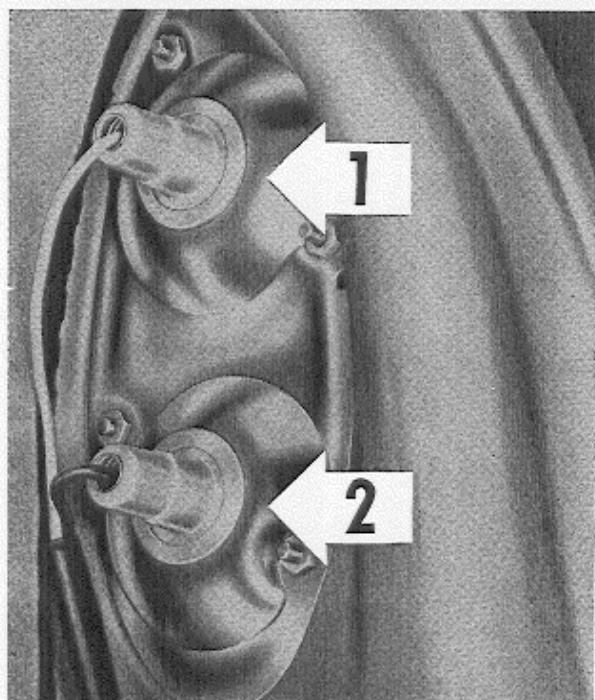


Fig. 76. Position of bulbs in the rear lamp.

1. Direction indicator      2. Rear light and stop light

## Instrument and interior lighting

The instrument lighting consists of two bulbs attached to the instrument unit and is accessible from the reverse side of the instrument panel.

There are also four control lamps fitted in the instrument unit. All control lamps are accessible for replacement from the reverse side of the instrument panel.

The interior lighting consists of a lamp in the roof. The bulb in this is accessible for replacement after the glass has been removed.

The glove compartment lighting is operated by means of a separate switch.

The bulb is accessible for replacement from the reverse side of the instrument panel.

## Lighting switch

The pull switch for the headlights has three positions: off, parking and full and dipped headlights. The strength of the instrument lighting can be adjusted by turning the switch knob.

The switch is removed from the instrument panel as follows:

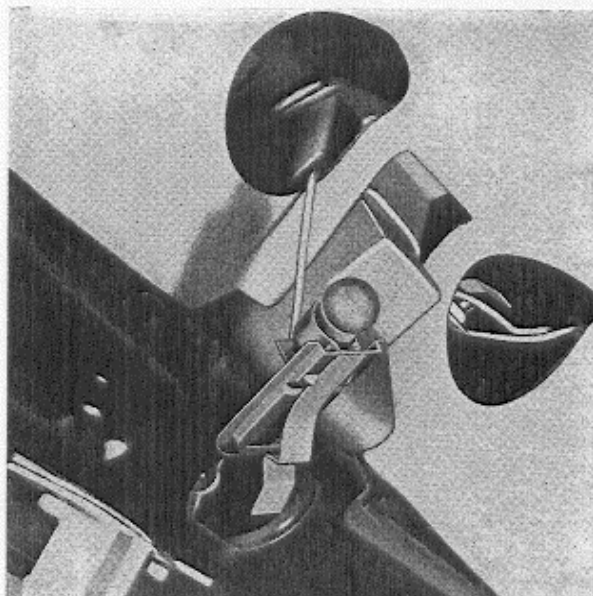


Fig. 77. Removing the bulb.

1. Remove the pull button by screwing it off.
2. Unscrew the nut which holds the lighting switch with a suitable tool, see Fig. 78.
3. Lift off the switch by first pulling it backwards and then downwards. See Fig. 79.
4. The special cable terminals are removed by pulling out from the cable holder on the contact.

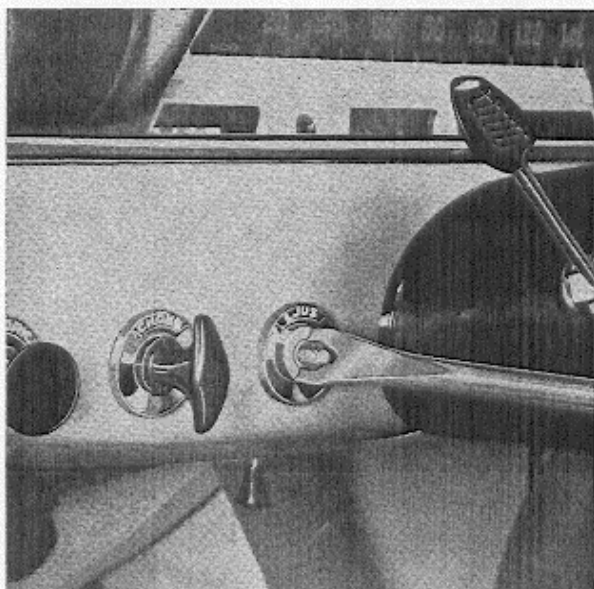
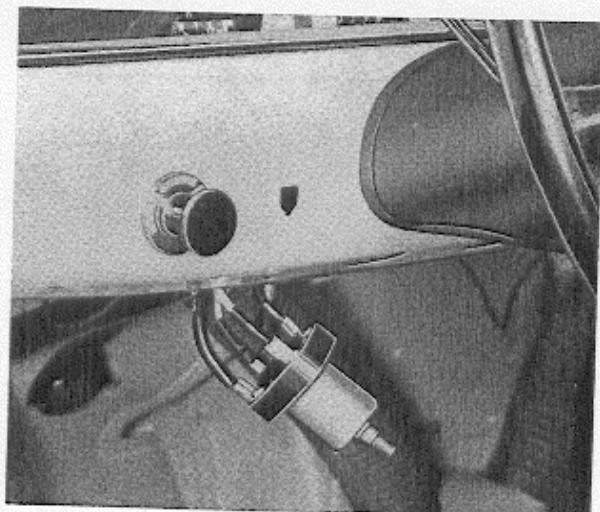
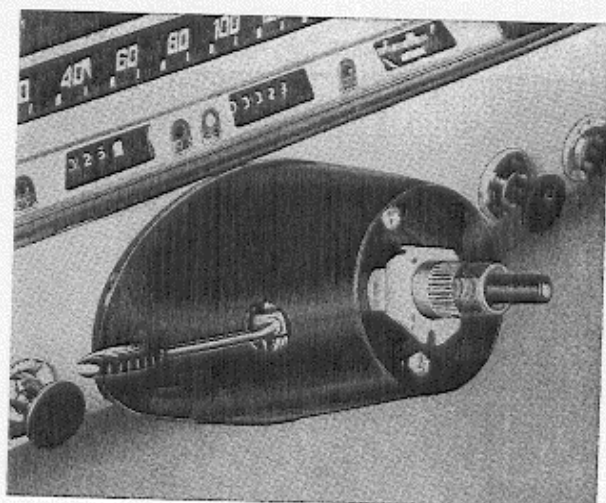


Fig. 78. Removing the lighting switch.



VOLVO  
24350

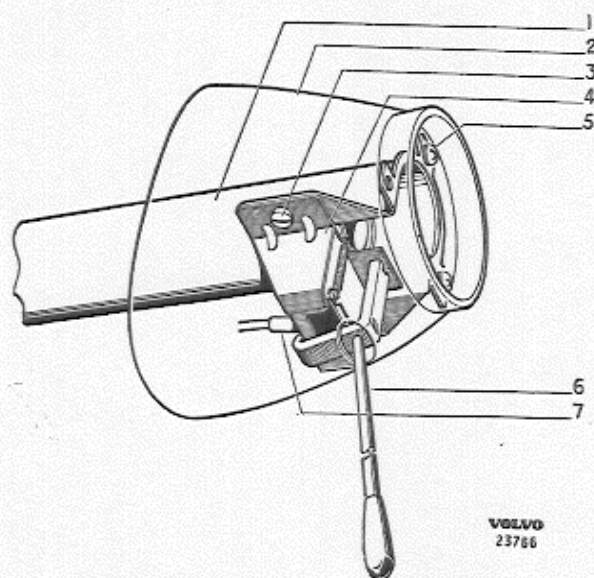
Fig. 79. Lighting switch removed.



VOLVO  
24017

Fig. 81. Actuator for direction indicator switch.

## Direction indicator switch Removing and fitting



VOLVO  
23766

Fig. 80. Direction indicator switch.

- |                |           |                  |
|----------------|-----------|------------------|
| 1. Jacket tube | 4. Switch | 6. Control lever |
| 2. Casing      | 5. Screw  | 7. Earth lead    |
| 3. Screw       |           |                  |

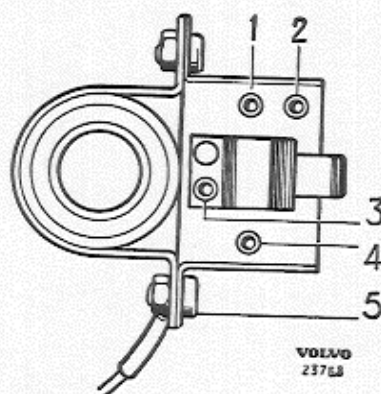
1. Remove the steering wheel in accordance with the instructions in Part 6.
2. Unscrew the three screws (5, Fig. 80) which hold the casing to the jacket tube, and lift this up.
3. Remove the leads on the underside of the

switch. This is done by pulling them out of their holders.

4. Unscrew the two screws which hold the switch to the jacket tube.

Adjusting the position of the switch is done by turning the jacket tube. Concerning this, see Part 6.

Concerning connecting the leads, see Fig. 82.



VOLVO  
23763

Fig. 82. Direction indicator switch terminals (seen from underneath).

- |                     |                           |
|---------------------|---------------------------|
| 1. Right flasher    | 4. Lead from flasher unit |
| 2. Left flasher     | 5. Earth lead             |
| 3. Headlight signal |                           |

## Horns Removing and fitting

The horns are attached to the body by means of a flexible steel bar. The horns receive current from

## Changing over self-parking position

When delivered from the factory, the windscreen wiper parks to the right viewed from the driving position. The parking position can be changed over, that is to say, the wiper blades park to the left on the windscreen, by turning the contact plate (2, Fig. 87) through 180°. (Auto-Lite wipers). The nut (11), steel washer (12) and fibre washer (13) are first removed, after which the contact plate (2), can be lifted up and turned. The SWF wiper can be changed over by removing the shaft (1, Fig. 87) and turning through 180°.

## Electrical leads

The wiring diagram shows how the electrical leads connect the various components, and also shows the marking and cross-sectional area of the leads. The leads have different colours to facilitate fitting and fault tracing. When fault tracing, it is important that this is carried out in accordance with the wiring diagram.

If a lead is broken or earthed, it must be replaced.

When doing this, it is most important that the new lead has at least the same cross-sectional area as the old one. If the area is too small, this can lead to overloading and dangerous heating of the lead.

## Leads for extra equipment

For fitting extra electrical equipment at the rear of the vehicle, for example, rear window fan and

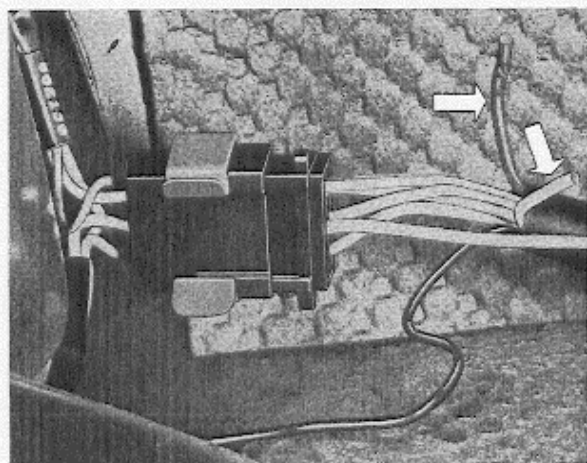
VOLVO  
26548

Fig. 89. Connecting piece for stop light, rear light, direction indicators, and leads for extra equipment (arrows).

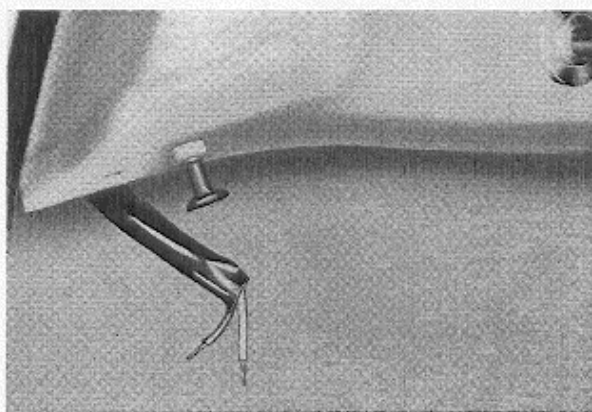
VOLVO  
24907

Fig. 90. Leads for extra equipment.

reversing lamp, two leads are included in the cable harness. The cable harness is placed along the roof of the vehicle inside the headlining. The extra leads are accessible under the instrument panel as shown in Fig. 90 and at the rear in the rear in the luggage compartment as shown in Fig. 89.

## Fuses

These consist of four melt-type fuses fitted in a fusebox placed on the left-hand side of the bulkhead as shown in Fig. 91.

The fuses in the fusebox must be replaced when burnt out. The fuses must never be repaired or replaced with nails, wire, etc.

The fuses on cars have a rating of 8 and 25 A.

The table below shows data for the fuses.

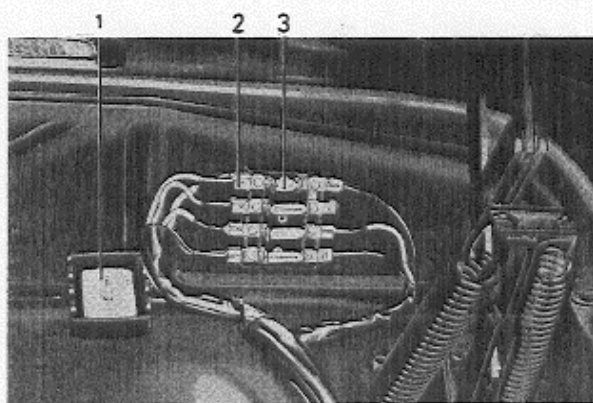
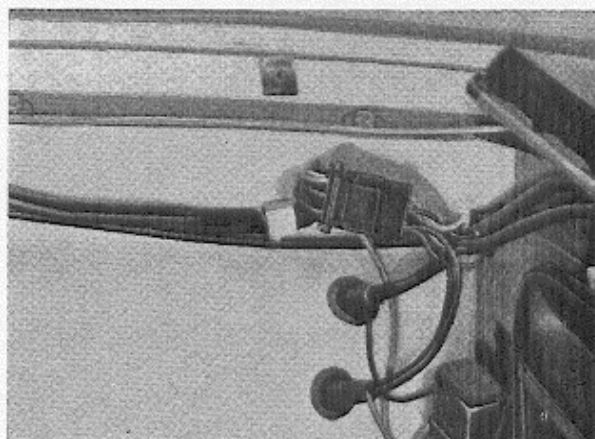
VOLVO  
26546

Fig. 91. Fuses.

1. Cover for fusebox 2. Terminal 3. Fuse



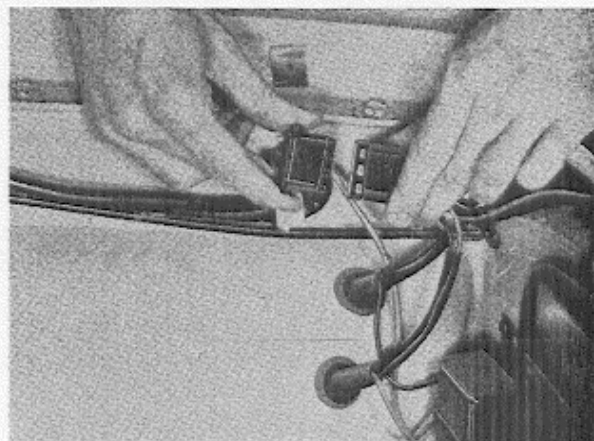
VOLVO  
24341

Fig. 92. Connecting contact for full and dipped headlights.

Rating .....	8 A	25 A
Rated current at continuous loading .....	8 A	25 A
Current which the fuse should withstand for at least one hour	12 A	35 A
Current for which the fuse should melt within one hour .....	20 A	62.5 A

## Heater

Concerning the function and method of operation of the heater, see Part 11.



VOLVO  
24342

Fig. 93. Connecting contact removed.

## Removing the fan motor

1. Disconnect the current-carrying lead on the connecting piece.
2. Unscrew the six screws which hold the fan motor to the radiator casing and lift this out as shown in Fig. 94.

Fitting is done in the reverse order. The fan motor is provided with self-lubricating bushings so that lubricating need not be done after a certain time but only in connection with reconditioning.



VOLVO  
26545

Fig. 94. Removing the heater fan motor.

1. Turbine
2. Terminals for leads
3. Half-speed resistance
4. Fan motor

## Windscreen washer

The windscreen washer pump is driven by an electric motor. The pump is of the gear type.

When overhauling, the bushings and shafts are lubricated with oil. Brushes which are worn down more than half-way must be replaced.

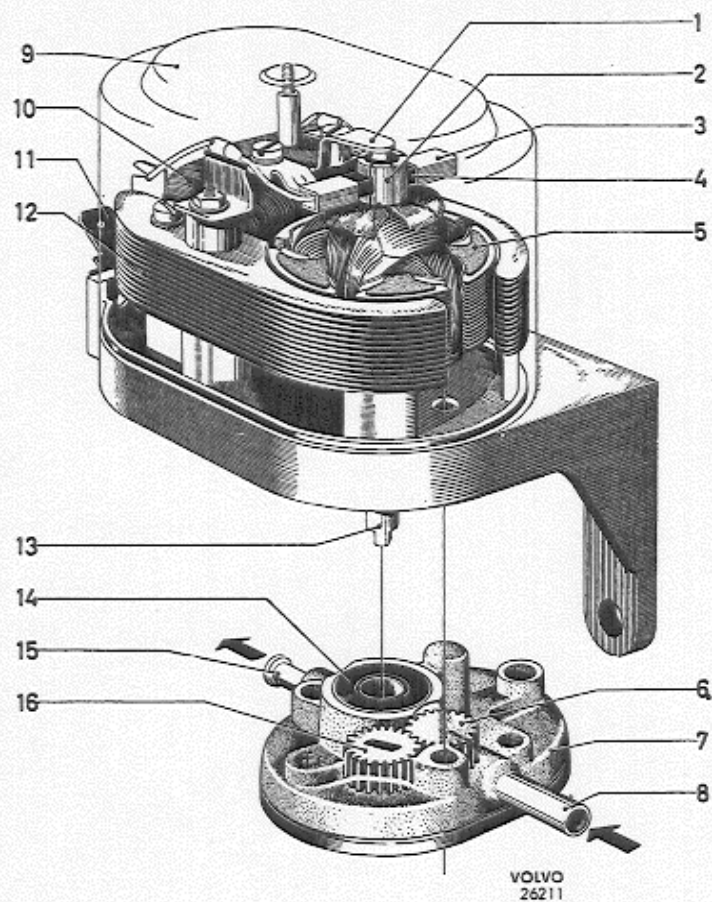


Fig. 95.

*Windscreen washer.*

1. Stop lip
2. Commutator
3. Brush holders
4. Brush
5. Rotor
6. Pump gear
7. Pump housing
8. Inlet pipe
9. Casing
10. Field winding
11. Terminal
12. Pole shoe
13. Rotor shaft
14. Seal
15. Outlet pipe
16. Pump gear

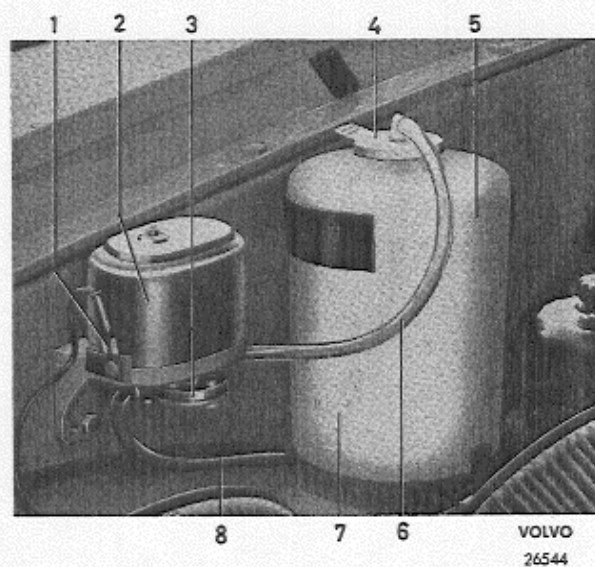


Fig 96.

*Windscreen washer fitted.*

1. Terminal
2. Electrical motor
3. Gear pump
4. Filling cap
5. Liquid container
6. Hose
7. Non-return valve
8. Hose to nozzle

## FAULT TRACING

When fault tracing, it is of the utmost importance to proceed systematically. This applies particularly to the electrical system. If there is some part of the electrical system which does not function satisfactorily, the reason for the trouble must always be established before any measures are taken for repair or replacement. It is therefore not sufficient just to replace the faulty part or instrument without first finding out by means of testing that the fault

actually lies in the part concerned, or whether it is caused by an outside influence. The procedure when fault tracing should thus be as follows:

1. Find out which part is faulty.
2. Establish the reason for the occurrence of the fault.
3. Repair or replace the parts concerned.

	<b>FAULT</b>	
<b>REASON</b>		<b>REMEDY</b>

### Battery

#### Battery discharged or does not hold the charge

Insufficient charge from dynamo.  
 Acid level in battery too low.  
 Loose or corroded terminals.  
 Shorting in brake contact.  
 Internal short in battery.

Adjust the charging control.  
 Top-up with distilled water.  
 Clean the cable terminals and tighten them properly.  
 Replace the brake contact.  
 Characterized by the fact that the specific gravity of the acid does not rise during continued charging. The battery must be replaced.

#### The battery becomes abnormally warm or gases strongly

Dynamo charges excessively.  
 Acid level too low.  
 Battery has been poorly charged.  
 Internal short.

Adjust the charging control.  
 Top-up with distilled water.  
 Have the battery charged.  
 Replace the battery.

### Starter motor

#### The starter motor does not function

Battery discharged.  
 Poor connection and (or) earthing.  
 Faulty control solenoid.

Examine the battery. Charge up or replace the battery.  
 Check the connections on the battery, starter motor and control solenoid.  
 Press the starter contact and check that the solenoid engages. If not, check to see whether current is obtained from the starter contact when this is in the starting position. See also under "Faulty starter motor". A faulty solenoid must be replaced.

Faulty starter motor

Test by disconnecting the battery lead from the solenoid and holding it against the connection to the starter motor. If the starter motor does not function, it must be removed for testing and repair. If the starter motor does not function, do not hold the lead against the terminal for more than a few seconds.

### The starter motor has poor output

Battery in poor condition.

Test and charge up if necessary.

Large resistance in starter motor circuit.

Examine all lead connections on the starter motor and the leads between the motor and chassis. Ensure that the contact surfaces are clean, that all cable terminals are well soldered and tighten the leads properly.

Poor contact in control solenoid.

Compare the stater motor output with and without the control solenoid by disconnecting the lead on the solenoid and holding it directly onto the starter motor output stud. A faulty control solenoid must be replaced.

Faulty starter motor.

Remove and test the starter motor.

### The starter motor spins without engaging the flywheel ring gear

Ring gear on flywheel damaged.

Remove the plate under the engine in front of the flywheel, see Part 1.

A damaged ring gear must be replaced.

Drive pinion damaged.

Remove the starter motor and replace the damaged parts.

Drive pinion and/or engaging mechanism damaged.

Remove the starter motor and replace damaged parts.

## Dynamo and charging control

### Too low or no charging when the battery is discharged

Poor contact or damaged leads.

Inspect all leads between the dynamo, charging control and battery for loose contacts, broken leads, poor insulation, corrosion and earthing.

Fan belt worn out or insufficiently tensioned.

Replace or tension the fan belt.

Faulty dynamo.

Disconnect the lead for the rotor current and the lead to the battery from the charging control and connect an ammeter in series with these. Start the engine and let it run at idling speed. Connect the terminal for the field current to the dynamo housing. If the ammeter at this stage, and when the speed is increased, shows too small a reading, the dynamo must be removed for examination and repair.

Note. Never run the dynamo when connected as above, at so high a speed that the maximum current is exceeded.

Faulty charging control.

Test and adjust the charging control. See under the heading "Charging control".

### Charging too high with the battery fully charged

Faulty dynamo.

Let the dynamo run at about half charge. Disconnect the field lead from the charging control. If charging does not fall to zero, also disconnect the field lead from the dynamo. If charging falls to zero, examine the lead, and if this is intact, the dynamo is faulty so that it must be removed for repair. Examine the chassis connections of the dynamo, *charging control and battery*.

High resistance at chassis connecting points.

Test and adjust the charging control.

Faulty charging control.

Proceed in accordance with the directions under the heading "Charging control".

## SPECIFICATIONS

### Battery

Type .....	Boliden 107 GM 60 or corresponding
Earthed .....	Negative terminal
System voltage .....	12 V
Battery capacity, standard .....	60 Ah
<i>Electrolyte specific gravity:</i>	
Fully charged battery .....	1.275—1.285
When re-charging is necessary .....	1.230
Recommended charging current .....	4.5 A

### Ignition system

Firing order .....	1—3—4—2
Ignition setting: .....	B 18 A                      B 18 D
At 1500 engine r.p.m. (vacuum regulator disconnected) 97 octane (Research Method) .....	21—23° B.T.D.C.    22—24° B.T.D.C.
Ignition coil .....	Bosch ZS/KZ 1/12 A (14/3)
Sparking plugs, type .....	Bosch W 175 T 1 or corresponding
thread .....	14 mm
sparking plug gap .....	0.7—0.8 mm (0.028—0.032")
tightening torque .....	3.8—4.5 kgm (27.5—32.5 lb.ft.)

### Distributor

Type .....	Bosch VJU 4 BL 33
------------	-------------------

### Test values

Direction of rotation .....	Anti-clockwise	
<i>Ignition setting curves:</i>		
Centrifugal regulator:		
Crankshaft degrees .....	0	10
Crankshaft r.p.m. ....	750—1050	1300—1850
	20	22 ± 3
	2300—2900	2800—3300
Vacuum regulator:		
Crankshaft degrees .....	0	15 ± 4
Vacuum, Hg, cm (in.) .....	6—10	18
	(2.36—3.94")	(7.09")
Contact breakers, gap .....	0.4—0.5 mm	
	(0.016—0.020")	
contact pressure .....	0.4—0.5 kg (0.88—1.10 lb)	
closing angle .....	60°	

## Dynamo

Type, B 18 A .....	Bosch LJ/GG 240/12/2400 AR6
B 18 D .....	Bosch LJ/GG 240/12/2400 AR7
System voltage .....	12 V
Rated effect .....	240 W
Max. current, continuous .....	30 A
Earthed .....	Negative terminal
Direction of rotation .....	Clockwise
Ratio, engine—dynamo .....	1.8:1
Brushes, designation .....	WSK 43 L 1
number .....	2
contact pressure .....	450—600 grammes (16—21 oz.)

## Test values

Field winding resistance .....	4.8+0.5 Ohm
Charging, cold dynamo, 240 W .....	2300 r.p.m.
warm dynamo, 240 W .....	2500 r.p.m.
Speed at rated voltage, unloaded .....	1700 r.p.m.

## Charging control

Type .....	Bosch RS/VA 240/12/2
Equalizing resistance aR .....	15.5—16.5 ohm
Control resistance wR .....	8—9 ohm

## Test values

Reverse current relay:	
Adjusted for, cutting-in at .....	12.1—12.8 V
reverse current at .....	2.0—7.5 A
Voltage control:	
Control voltage, dynamo at no load (idling) .....	13.9—14.9 V
loaded .....	12.9—14.1 V
Loading current:	
Cold dynamo and charging control .....	45 A
Warm dynamo and charging control .....	30 A

## Starter motor

Type .....	Bosch EGD 1/12 AR 37
System voltage .....	12 V
Earthed .....	Negative terminal
Direction of rotation .....	Clockwise
Output .....	Approx. 0.9 h.p. at $-10^{\circ}$ C ( $14^{\circ}$ F) approx. 1.2 h.p. at $+20^{\circ}$ C ( $68^{\circ}$ F)
Number of teeth on drive pinion .....	9
Brushes, designation .....	DSK 35/5
number .....	4

## Test values

### Mechanical

Rotor axial clearance	0.1—0.3 mm (0.004—0.012")
Brush spring tension	0.8—0.9 kg (1.76—1.98 lb.)
Distance of pinion from ring gear	2.5—3 mm (0.10—0.12")
Rotor brake friction torque	3—5 kgcm (2.6—4.3 lb.in)
Pinion free-wheel torque	1.3—1.8 kgcm (1.13—1.56 lb.in.)
Tooth flank clearance	0.35—0.6 mm (0.014—0.023")
Pinion modulus	2.11

### Electrical

Starter motor unloaded:	
11.5 V and 40—60 A	5500—7500 r.p.m.
Starter motor loaded:	
10 V and 200 A	1100—1300 r.p.m.
Starter motor locked:	
r.p.m.=0.8 V	400—450 A
Control solenoid:	
Cut-in voltage	Max. 7 V
Adjusting measurement "a" (see Figure)	32.2 ± 0.1 mm (1.268 ± 0.004")

### Bulbs

	Effect	Number	Socket
Bulbs, symmetrical lighting	45/40 W	2	Ba 20 d
asymmetrical lighting	45/40 W	2	P 45 t
Direction indicators/parking lights	20/5 W	2	Ba 15 d spec.
Roof light	10 W	1	S 8
Glove compartment light	2 W	1	Ba 9 s
Direction indicators, rear	20 W	2	Ba 15 s
Stop lights/rear lights	20/5 W	2	Ba 15 d spec.
Number plate lighting	5 W	1	Ba 15 s
Instrument lighting	2 W	2	Ba 9 s
Control lamps, full headlights	2 W	1	Ba 9 s
direction indicators	2 W	1	Ba 9 s
charging	2 W	1	Ba 9 s
oil pressure	2 W	1	Ba 9 s

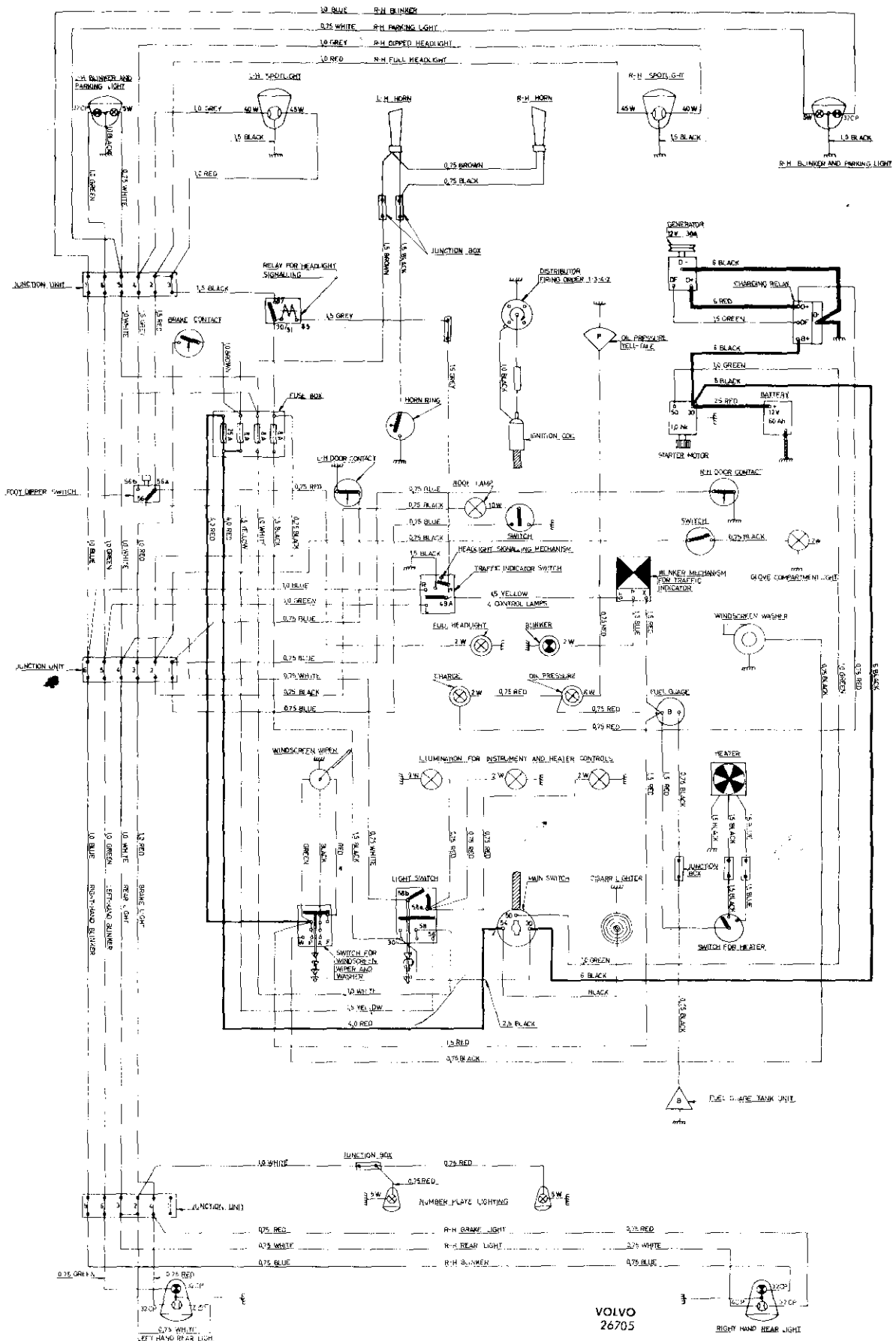


Illustration 1. Wiring diagram with effect from chassis number 84300.

## List of contents 52

Description .....	1
Repair instructions .....	7
Battery .....	7
Starter motor .....	9
Dynamo .....	17
Charging control .....	23
Distributor .....	25
Headlights .....	28
Flashers and parking lights .....	32
Rear lights .....	32
Number plate lighting .....	33
Instrument and interior lighting .....	33
Lighting switch .....	33
Direction indicator switch .....	34
Windscreen wipers .....	35
Windscreen washer .....	36
Horns .....	37
Electrical leads .....	37
Fuses .....	38
Leads for extra equipment .....	38
Heater .....	39
Fault tracing .....	40
Specifications .....	43