



**CARS**

Part 4 (43)

GEARBOX  
(M 40, M 41)

P 1800

# **SERVICE MANUAL**

## CONTENTS

Description .....	1
Repair instructions .....	3
Work which can be done with the gearbox in position .....	3
Removing .....	4
Dismantling .....	4
Inspection .....	6
Assembling .....	8
Fitting .....	9
Fault tracing .....	10
Tools .....	11
Specifications .....	12
Illustration	

# DESCRIPTION

(Concerning gearbox with overdrive (M 41), see also "P 120, P 1800 Part 4 (43), Overdrive")

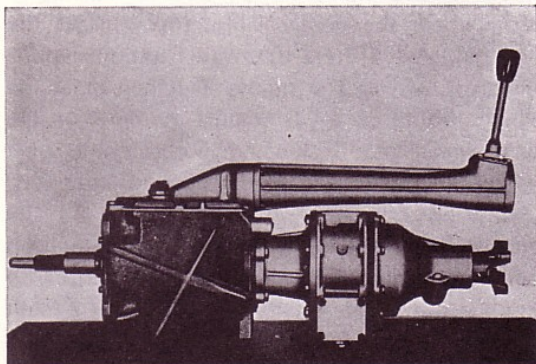


Fig. 1. Gearbox with overdrive

The M 40 gearbox (with overdrive — M 41) for the P 1800 is a fully synchronized four-speed gearbox. It can also be equipped with an overdrive, connected to the fourth gear, thus giving five forward speeds.

The appearance of the gearbox is illustrated in Fig. 1 and Illustration A. All gears, except reverse, are in constant mesh. In the neutral position the gears on the main shaft rotate freely. For this reason they are provided with needle bearings. When engaging a gear, the corresponding gear wheel is connected to the main shaft by means of an engaging sleeve.

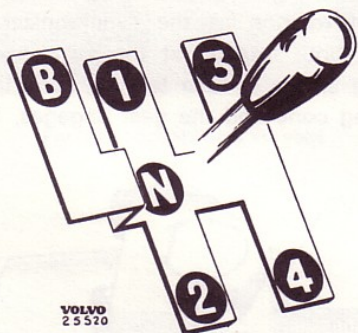


Fig. 2. Gear lever positions

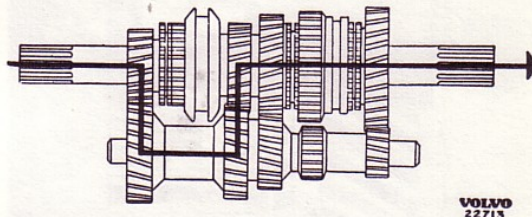


Fig. 5. 3rd speed

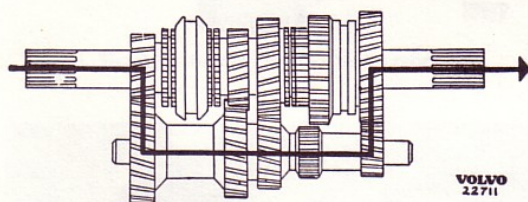


Fig. 3. 1st speed

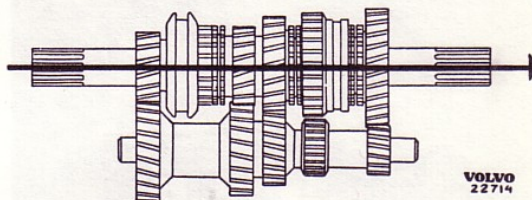


Fig. 6. 4th speed

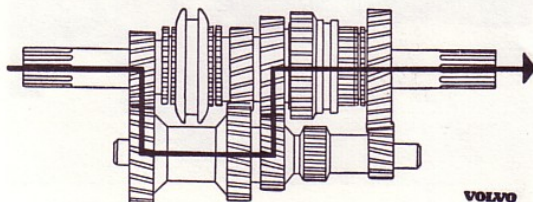


Fig. 4. 2nd speed

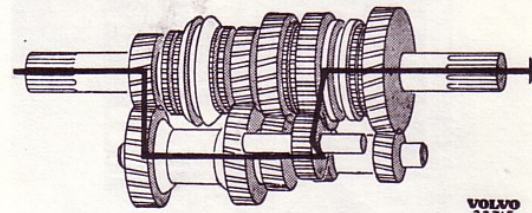


Fig. 7. Reverse

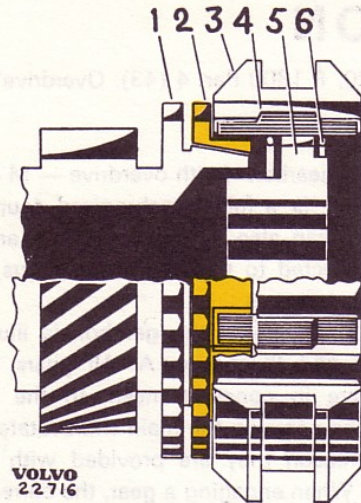


Fig. 8. Neutral position

- |                       |                     |
|-----------------------|---------------------|
| 1. Ring gear          | 4. Guide            |
| 2. Synchronizing cone | 5. Synchronizer hub |
| 3. Engaging sleeve    | 6. Spring           |

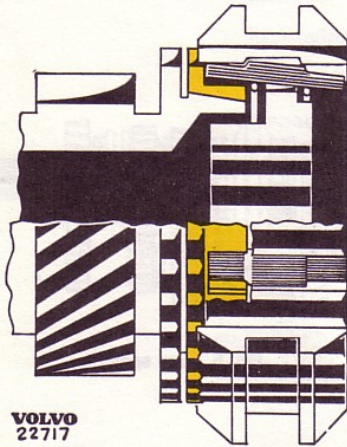


Fig. 9. Synchronizing

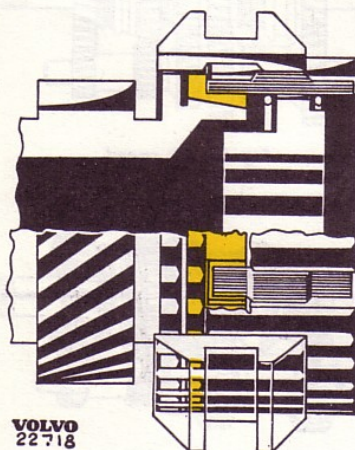


Fig. 10. Gear engaged

The gear lever positions are shown in Fig. 2. The power transmission path of the different speeds is shown in Figs. 3—7.

The design and function of the synchronizing mechanism is shown in Figs. 8—10. When a gear is engaged, the gear selector fork presses the engaging sleeve (3, Fig. 8) towards the corresponding gear wheel. The guides (4) then press the synchronizing cone (2) against the cone on the gear wheel (1). If the synchronizer and gear wheel are rotating at different speeds, the synchronizing cone will turn in relation to the engaging sleeve. However, the synchronizing cone is prevented from turning more than half a tooth width by the guides, see Fig. 9. The teeth on the synchronizing cone have half their width in contact with the teeth on the engaging sleeve and in this way prevent it from engaging. Through the friction between the synchronizing cone on the gear wheel, the gear wheel attains the same speed of rotation as the synchronizer. When they are both rotating at the same speed the engaging sleeve is able to turn back the synchronizing cone and the gear engages, Fig. 10.

# REPAIR INSTRUCTIONS

## WORK WHICH CAN BE DONE WITH GEARBOX IN POSITION

### Replacing sealing ring

1. Carry out operations 1—4 under the heading "Removing" as far as necessary.
2. Slacken the nut for the yoke. Use spanner SVO 2409 as a counterhold, see Fig. 11. Pull off the yoke. Use puller SVO 2261 for round flanges and SVO 2262 for yokes, see Figs. 12 and 13.
3. Pull out the old sealing ring with puller SVO 4030, see Fig. 14. Fit the new sealing ring with the help of sleeve SVO 2413, see Fig. 15.
4. Press on the flange with SVO 2304, see Fig. 16. Fit on remaining parts.

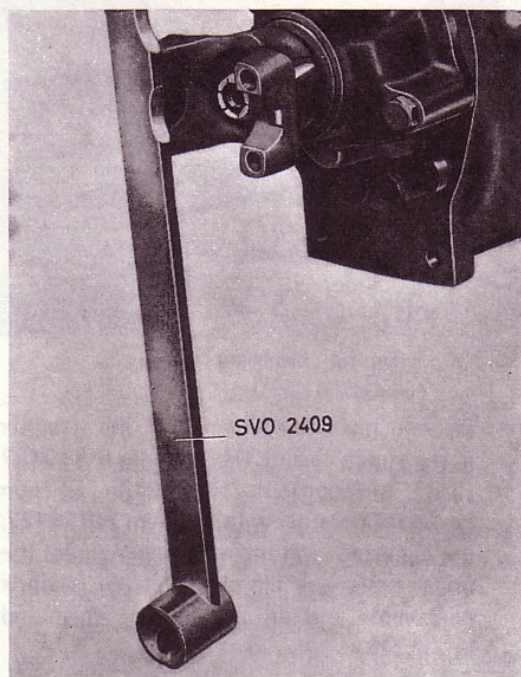


Fig. 11. Counterhold for yoke

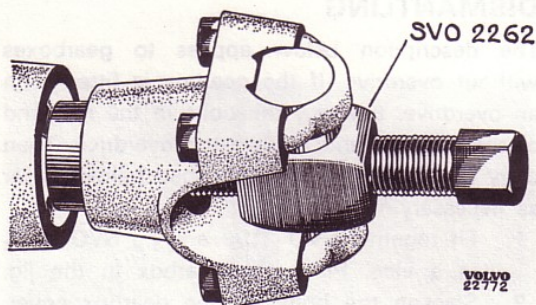


Fig. 12. Removing yoke, early prod.

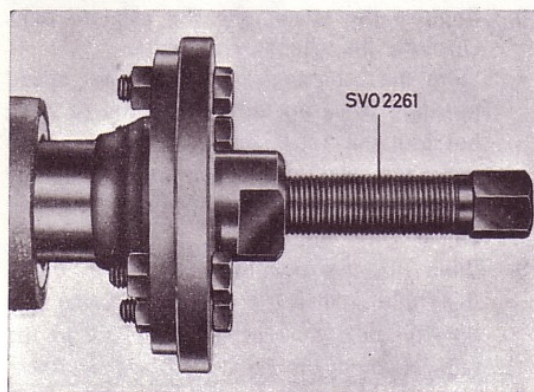


Fig. 13. Removing flange, late prod.

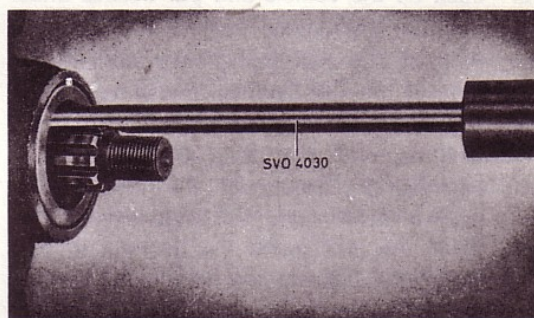


Fig. 14. Removing sealing ring

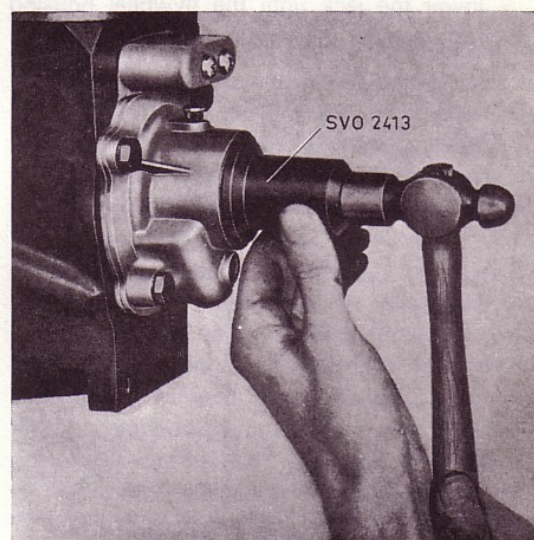


Fig. 15. Fitting sealing ring

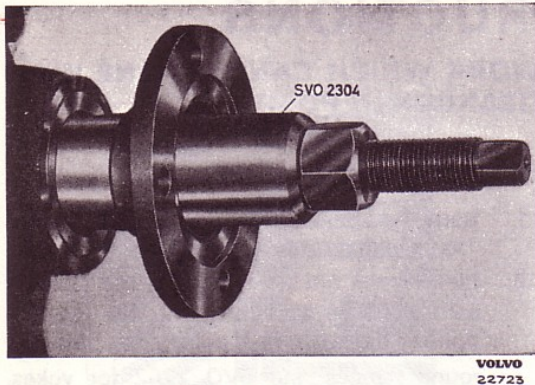


Fig. 16. Fitting flange

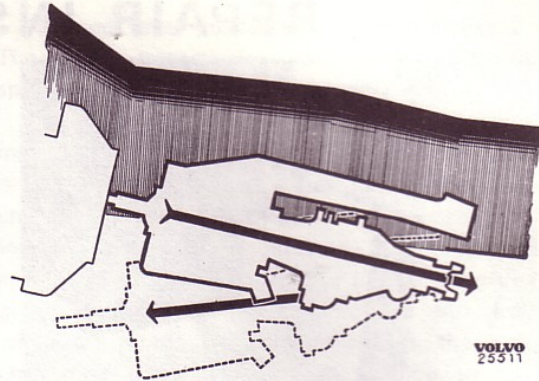


Fig. 18. Removing gearbox

### REMOVING

1. Lift off the tunnel mat. Slacken and lift up the gear lever. Remove the cover on the tunnel and disconnect the leads from the contacts for the stop lights and, if fitted, the overdrive.
2. Jack up the vehicle and put trestles under the front and rear axles. Slacken the exhaust pipe at the manifold flange and at the bracket on the flywheel housing.
3. Uncouple the propeller shaft from the gearbox and rear axle flanges. Pull it backwards. Disconnect the speedometer cable and the lead for the overdrive solenoid.
4. Place the jack under the gearbox to take its weight. Slacken and remove the support member under the gearbox. Place a wooden block between the engine and the cowl and lower the jack until the flywheel housing rests against the wooden block.

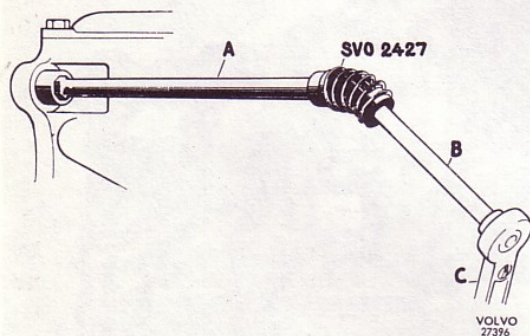


Fig. 17. Removing gearbox bolts

- A = SVO 2487 or 2488
- B = Extension with 3/8" square end
- C = Ratchet handle

5. Slacken the bolts which hold the gearbox to the clutch casing. Use spanner SVO 2487 (3/8" hexagon) or SVO 2488 (8 mm hexagon) together with ball joint SVO 2427, the extension and the ratchet handle for the upper bolts, see Fig. 17. Pull the gearbox backwards and lift it down as illustrated in Fig. 18.

### DISMANTLING

The description below applies to gearboxes without overdrive. If the gearbox is fitted with an overdrive, unscrew the bolts in the rear end of the gearbox and remove the overdrive. Then carry out the operations described below as far as necessary.

1. Fit together SVO 4109 and jig SVO 2044 in a vice. Place the gearbox in the jig.
2. Slacken the bolts for the gearbox cover. Lift off the cover. Remove the springs and interlock balls for the selector rails.
3. Remove the cover over the selector rails. Unscrew the selector fork bolts.
4. Slide the selector fork back to 1st speed position. Drive out the pin slightly (it must not foul the 1st speed gear wheel). Then move the selector fork forwards sufficiently to allow the pin to pass in front of the gear wheel. Drive out the pin.
5. Slide out the selector rails. When doing this, hold against the selector forks so that they do not come askew and jam on the rails. Remove the selector forks.
6. Unscrew the bolts for the rear cover. Turn the cover so that it does not lock the shaft

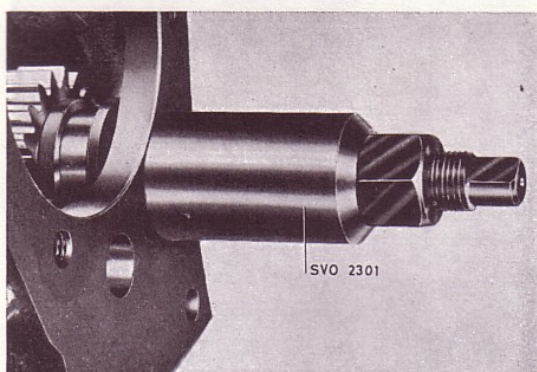


Fig. 19. Removing reverse gear

for the idler and reverse gears. Drive out the shaft for the idler gear.

**Note. The shaft must be driven out backwards.** Let the idler gear fall into the bottom of the gearbox.

7. Pull out the main shaft.
8. Unscrew the bolts and remove the cover over the input shaft. Prise out the sealing ring from the cover with a screwdriver or similar.

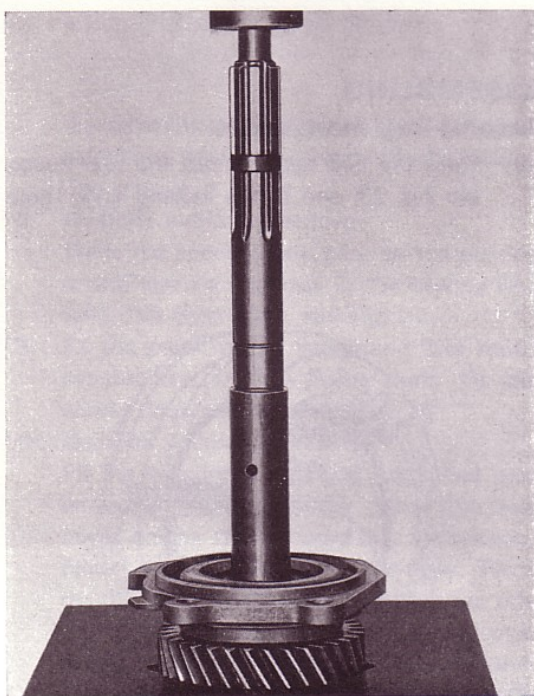


Fig. 20. Dismantling main shaft, M 41

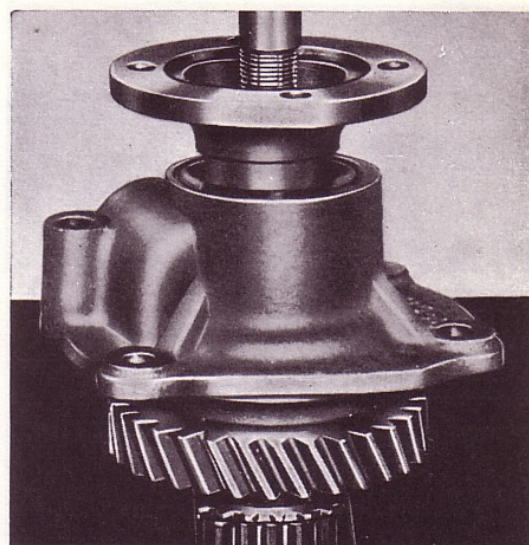


Fig. 21. Dismantling main shaft, M 40

9. Drive out the input shaft. If necessary, remove the locking ring and press the ball bearing off the shaft.
10. Take out the idler gear. Pull out the shaft (early prod.) for the reverse gear with puller SVO 2301, Fig. 19. Take out the reverse gear and other parts.

### DISMANTLING MAIN SHAFT

- 1a. Gearbox with overdrive (M 41).  
Remove the locking ring and press off the rotor for the overdrive oil pump. Remove the locking ring for the main shaft rear bearing. Slide the engaging sleeve for 1st and 2nd speeds forwards. Place the shaft in a press and support under the rear cover.
- 1b. Gearbox without overdrive:  
Unscrew the nut for the yoke. Use tool SVO 2409 as a counterhold on the yoke. Slide the engaging sleeve for 1st and 2nd speeds forward. Place the shaft in a press and support under the 1st speed gear wheel. Press out the shaft with a drift, see Fig. 21.
2. Remove the synchronizing cone, thrust washer, engaging sleeves, guides and springs from the shaft.

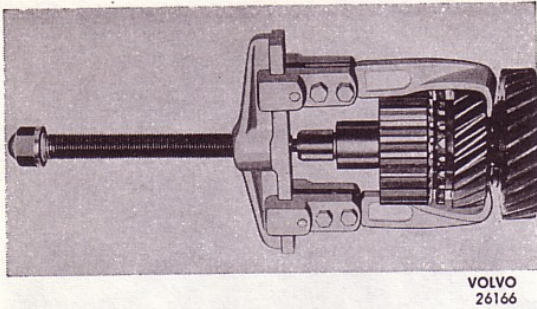


Fig. 22. Removing front synchronizer

3. Remove the locking ring on the front end of the shaft. Pull off the synchronizer hub and 3rd speed gear wheel with a puller, see Fig. 22. Remove the thrust washer.
4. Remove the locking ring and then the thrust washer, 2nd speed gear wheel synchronizing cone and spring.
5. Remove the sealing ring from the rear cover and take out the speedometer gear. If necessary, remove the locking ring and press out the ball bearing.

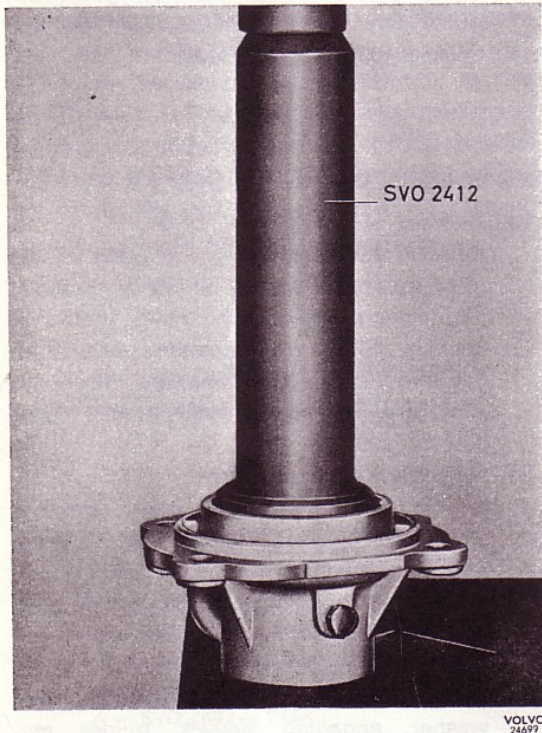


Fig. 23. Fitting ball bearing in rear cover

4-6

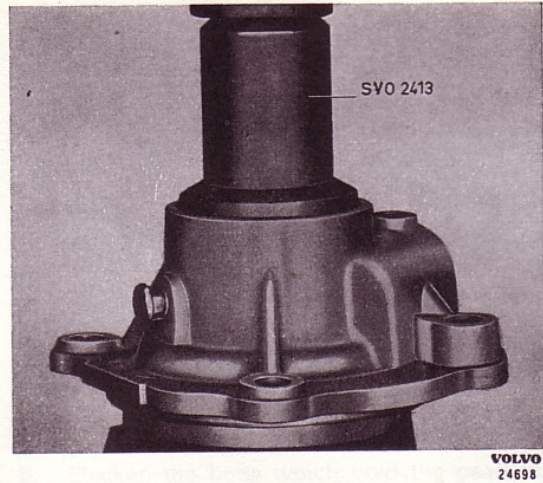


Fig. 24. Fitting sealing ring in rear cover

## INSPECTION

Check the gear wheels particularly for cracks or chips on the tooth surfaces. Damaged or worn gears should be replaced.

Check the synchronizing cones and all the other synchronizing components. Damaged or worn parts should be replaced.

Check the ball bearings particularly for scoring or cracks in the races or balls.

## ASSEMBLING

### Assembling main shaft

1. Press the ball bearing into the rear cover, see Fig. 23, and fit the locking ring. There

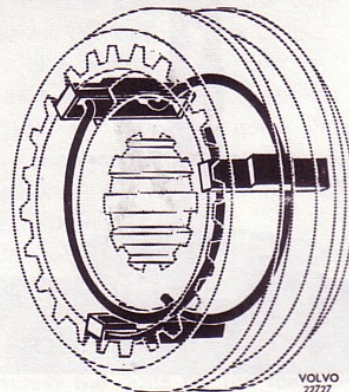


Fig. 25. Assembling synchronizer

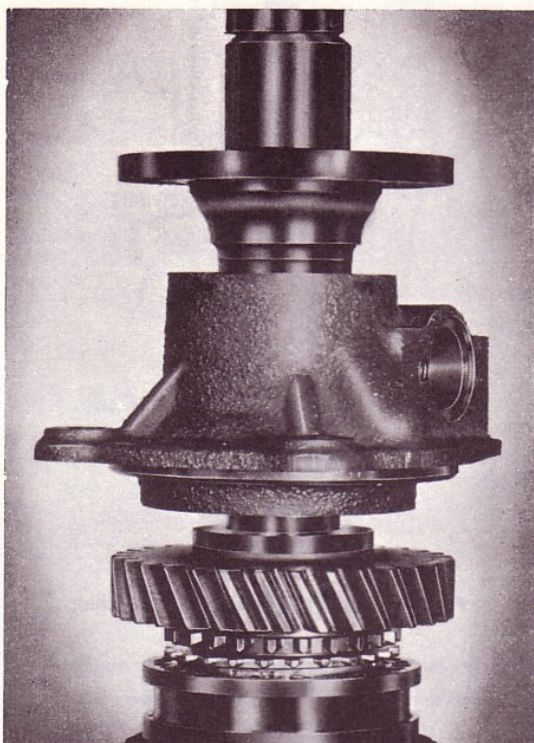
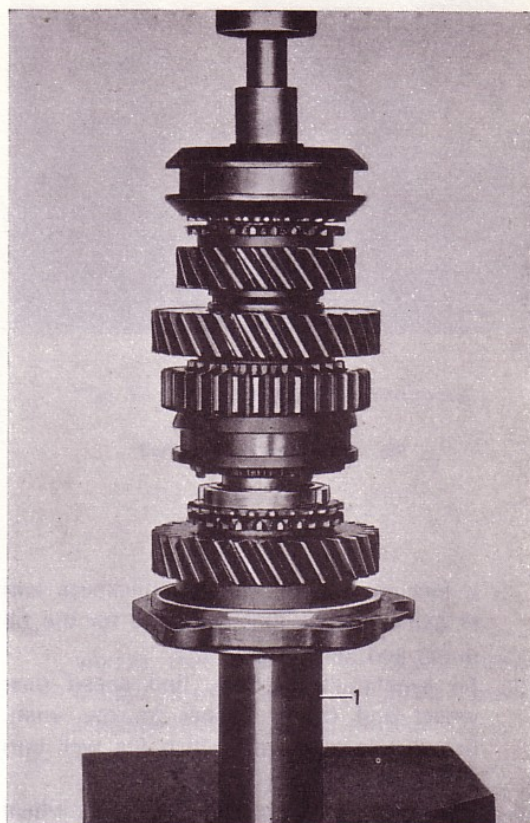


Fig. 26. Fitting rear cover, M 40

Fig. 27. Fitting rear cover, M 41  
1. Sleeve

are different thicknesses of locking ring so select one which completely fills the locking ring groove.

2. Gearbox without overdrive:

Place the speedometer gear on the bearing in the rear cover. Press in the sealing ring with drift SVO 2413, see Fig. 24.

3. Fit the parts for 1st speed and 2nd speed synchronizer on the main shaft. Fit the spring rings correctly, see Fig. 25.

4a. Gearbox without overdrive:

Fit the synchronizing cone, 1st speed gear wheel and thrust washer. Place the rear cover on the shaft. Ensure that the speedometer gear is positioned correctly. Place on the yoke. Use a sleeve which fits into the recess in the yoke, press on the cover and yoke, see Fig. 26. Place on the washer and nut for the yoke. Use tool SVO 2409 as a counterhold for the yoke and tighten the nut.

4b. Gearbox with overdrive (M 41):

Place the rear cover and ball bearing on a support ring or sleeve as shown in Fig. 27. Place on the thrust washer, the 1st speed gear wheel and synchronizing cone. Select

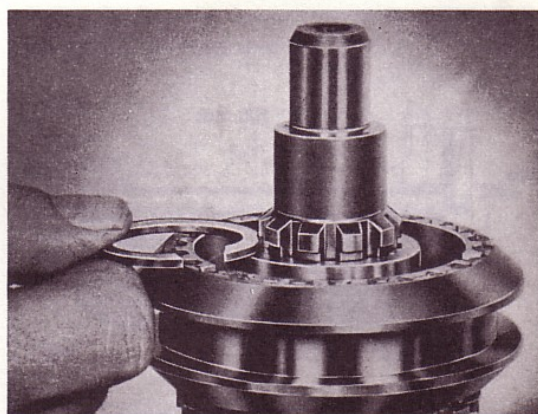


Fig. 28. Trying out locking ring

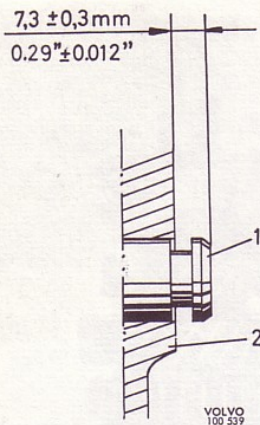


Fig. 29. Fitting reverse shaft

a locking ring of suitable thickness and fit same. Fit the key, eccentric for the oil pump and locking ring.

5. Fit synchronizing cone, 2nd speed gear wheel and thrust washer on the shaft. Select a locking ring which fits well into the groove on the shaft and fit it.
6. Fit the thrust washer, 3rd speed gear wheel and synchronizing cone on the shaft. Assemble the 3rd and 4th speed synchronizing parts. Fit the spring rings correctly, see Fig. 25. Then fit the synchronizer on the main shaft. Select a locking ring of the correct thickness and fit it, see Fig. 28.

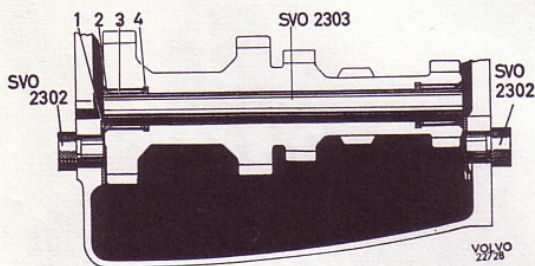


Fig. 30. Fitting idler gear

- |                   |                   |
|-------------------|-------------------|
| 1. Thrust washer  | 3. Needle bearing |
| 2. Spacing washer | 4. Spacing washer |

4-8

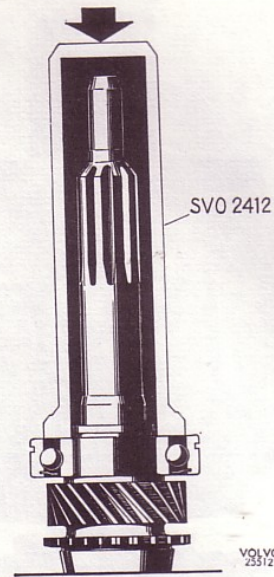


Fig. 31. Fitting ball bearing on input shaft

### Assembling gearbox

1. Fit the lever and guide stud. Fit the reverse gear and reverse shaft. Ensure that the groove in the reverse shaft (early prod.) is turned correctly. The late production reverse shaft, with turned groove, is fitted so that it projects 7.0—7.6 mm (0.276—0.300") outside the gearbox housing, see Fig. 29.
2. Place mandrel SVO 2303 in the idler gear. Place in spacing washers and needles (24 in each bearing). Use grease to hold the needles and washers in position.
3. Fix the washers to the housing with grease, and guide them into position with SVO 2302, see Fig. 30. Lay the idler gear in the bottom of the housing.
4. Press the bearing onto the input shaft with the help of drift SVO 2412, see Fig. 31. Select a locking ring of suitable thickness and fit it. Place the 14 bearing rollers for the main shaft in position on the input shaft. Use grease to hold the rollers in place. Press the input shaft into position in the housing. Press the sealing ring into the cover with drift SVO 2010. Then fit the cover over the input shaft. Do not forget the O-rings for the screws (late prod.).

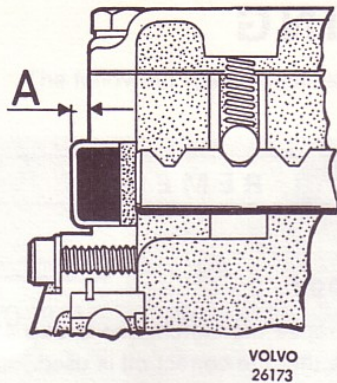


Fig. 32. Fitting end cap over selector rail  
A = approx. 4 mm (5/32")

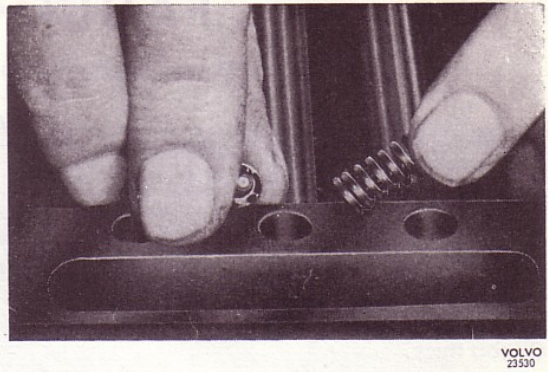


Fig. 33. Fitting interlock balls and springs

5. Place the main shaft in the housing. Turn the rear cover so that the countershaft can be fitted.
6. Turn the gearbox upside down. Fit the countershaft from the rear. Hold against SVO 2303 with the hand. Ensure that the thrust washers do not loosen and fall down.
7. Gearboxes without overdrive:  
Turn the rear cover correctly so that it locks the reverse shaft (early prod.). Fit the bolts for the cover.
8. Fit selector rails and forks. Move over the selector fork to the rear position when fitting the pin. Use a new pin. Fit the casing over the selector rails.

Note. If the end caps in the front end of the housing have been removed, these should be fitted in the same way as pre-

viously, that is to say, the centre end cap should project about 4 mm (5/32") outside the face of the housing, see Fig. 32.

9. Gearboxes with overdrive:  
Turn the cover correctly so that it locks the reverse shaft (early prod.). Ensure that the eccentric for the overdrive oil pump is turned upwards. Fit the overdrive unit. Use new washers for the spacer flange.
10. Place the interlock balls and springs in position, see Fig. 32. Fit the gearbox cover. Check that all gears engage and disengage freely.

## FITTING

Fitting is done in the reverse order to removing. Fill up the gearbox with oil.

# FAULT TRACING

FAULT	
REASON	REMEDY

## Gears difficult to engage

<p>Clutch does not disengage. Oil too thick. Synchronizing mechanism worn. Bearing bushing or gears worn. Selector rail or gears binding.</p>	<p>Adjust or repair the clutch. See Group 41. Make sure that the correct oil is used. Replace the worn parts. Replace damaged or worn parts. Replace damaged or worn parts.</p>
---	---

## One of the gears jumps out

<p>Worn bearings on shafts or gears. Worn grooves in selector rails or weak springs. Badly worn gears. Gearbox out of alignment with flywheel housing.</p> <p>Worn flywheel pilot bearing.</p>	<p>Fit new bearings. Replace damaged or worn parts. Replace any worn gear wheels. Check the flywheel housing with a dial indicator gauge and adjust if necessary (see Group 41). Clean all contact surfaces. Replace the bearing.</p>
--	---

## Noise

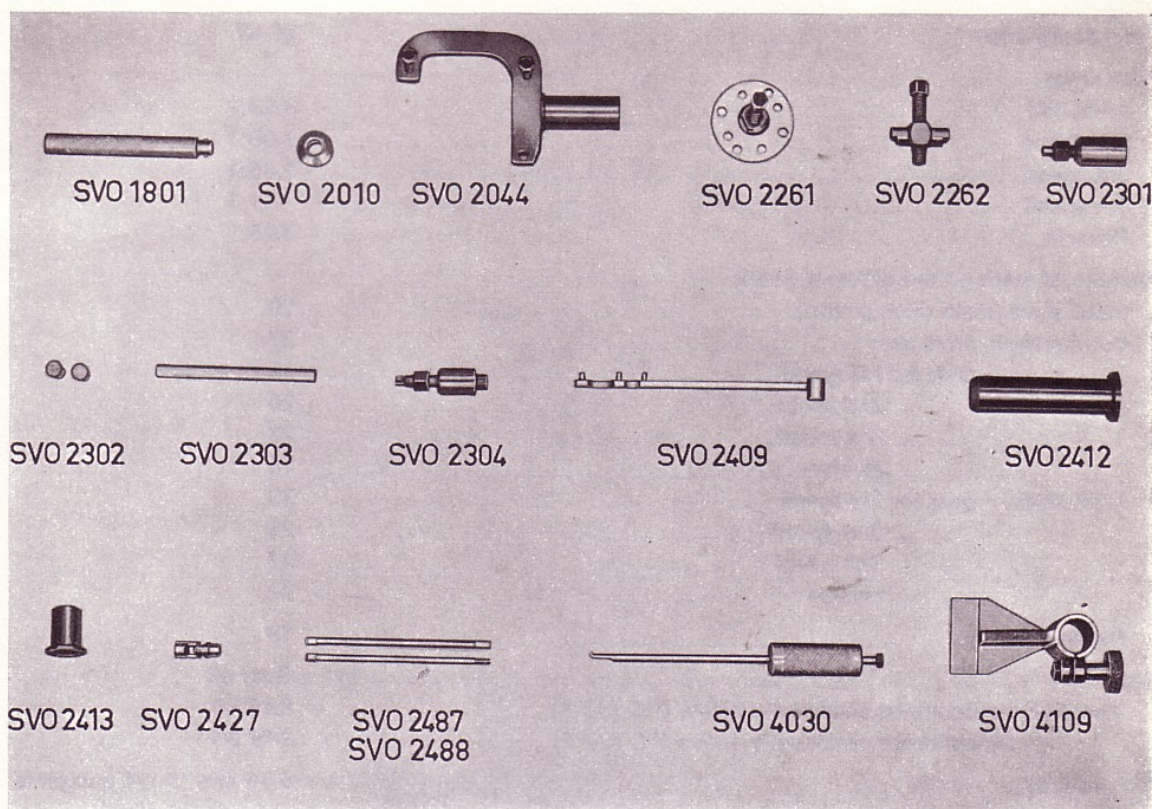
<p>Oil level too low. Worn or damaged bearings on shafts or gear wheels. Badly worn gear wheels.</p>	<p>Top up with oil as necessary. Replace the worn bearings.  Replace the worn gear wheels.</p>
--	--

## Oil leakage

<p>Sealing surface of flange worn. Rear sealing ring and bearing worn. Leakage between housing and rear cover. Leakage between housing and front bearing cover. Front sealing ring worn. Leakage between housing and cover.</p>	<p>Fit a new flange and sealing ring. Fit a new flange and sealing ring. Fit a new paper gasket. Fit a new paper gasket. Clean out the return hole. Fit a new sealing ring in the front bearing cover. Fit a new cork gasket.</p>
---	---

# TOOLS

The following special tools are required for carrying out repairs to the gearbox.



- SVO 1801 Standard handle 18×200 mm.
- SVO 2010 Drift for fitting sealing ring in cover for input shaft.
- SVO 2044 Jig for dismantling and assembling. Used with SVO 4109.
- SVO 2261 Puller for flange (yoke).
- SVO 2262 Puller for flange (yoke).
- SVO 2301 Puller for removing reverse gear shaft.
- SVO 2302 Locating tool for thrust washer. Used together with SVO 2303 when fitting idler gear.
- SVO 2303 Locating tool for fitting idler gear.
- SVO 2304 Press tool for flange.
- SVO 2409 Counterhold for flange (yoke).
- SVO 2412 Fitting tool for bearing on input shaft, for bearing on main shaft in rear cover and for fitting in housing of main shaft.
- SVO 2413 Tool for fitting sealing ring in rear cover.
- SVO 2427 Ball joint for spanners SVO 2487 and SVO 2488.
- SVO 2487 3/8" spanner for removing and fitting upper gearbox bolts.
- SVO 2488 8 mm spanner for removing and fitting upper gearbox bolts.
- SVO 4030 Puller for sealing ring on flange (yoke).
- SVO 4109 Holder for fixture SVO 2044.

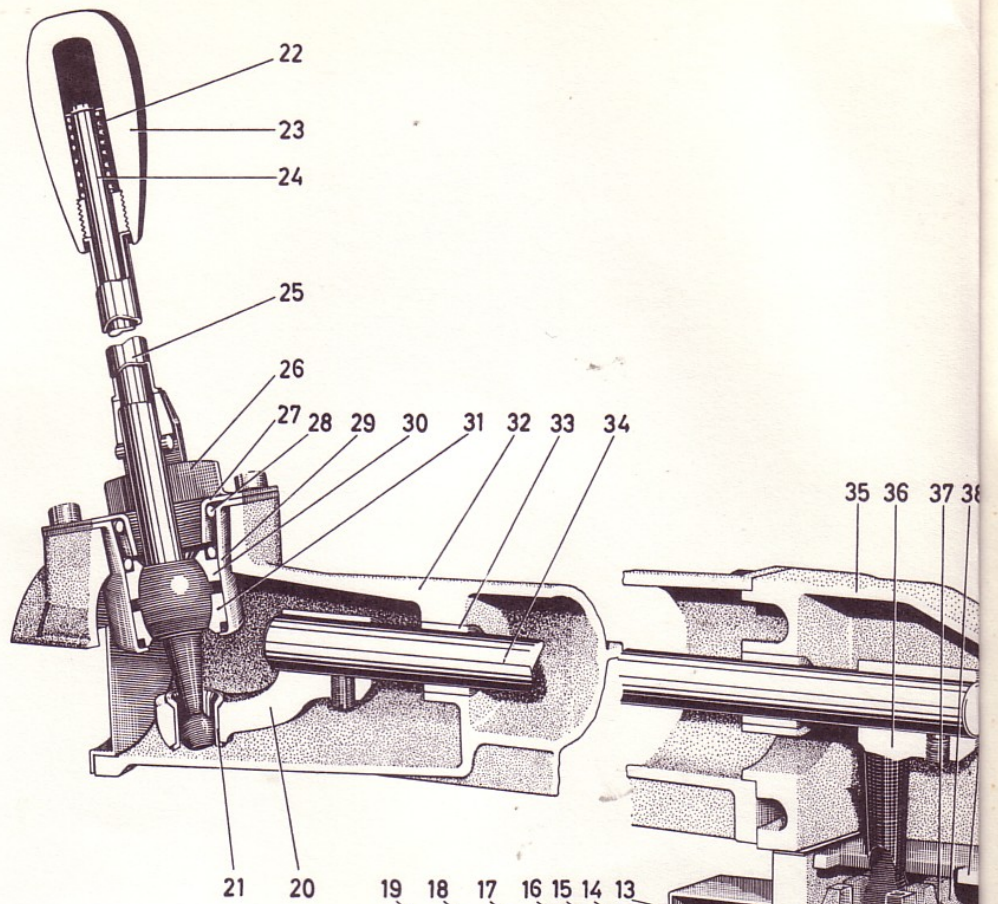
# SPECIFICATIONS

(Concerning gearboxes with overdrive (M 41), see also "P 120, P 1800 Part 4 (43), Overdrive")

Type designation .....	M 40
Gear ratios:	
1st speed .....	3.13:1
2nd speed .....	1.99:1
3rd speed .....	1.36:1
4th speed .....	1:1
Reverse .....	3.25:1
Number of teeth on the different gears:	
Input shaft (main drive pinion) .....	19
Countershaft, drive gear .....	27
gear for 1st speed .....	15
" " 2nd speed .....	20
" " 3rd speed .....	23
" " reverse .....	14
Main shaft, gear for 1st speed .....	33
" " 2nd speed .....	28
" " 3rd speed .....	22
" " reverse .....	32
Reverse gear .....	19
Lubricant *) .....	Gear oil
Viscosity, temperatures continually below 0°C (32°F) .....	SAE 80
temperatures continually above 0°C (32°F) .....	SAE 90
Oil capacity .....	0.75 litre (1 1/4 Imp.pints = 1 1/2 US pints)

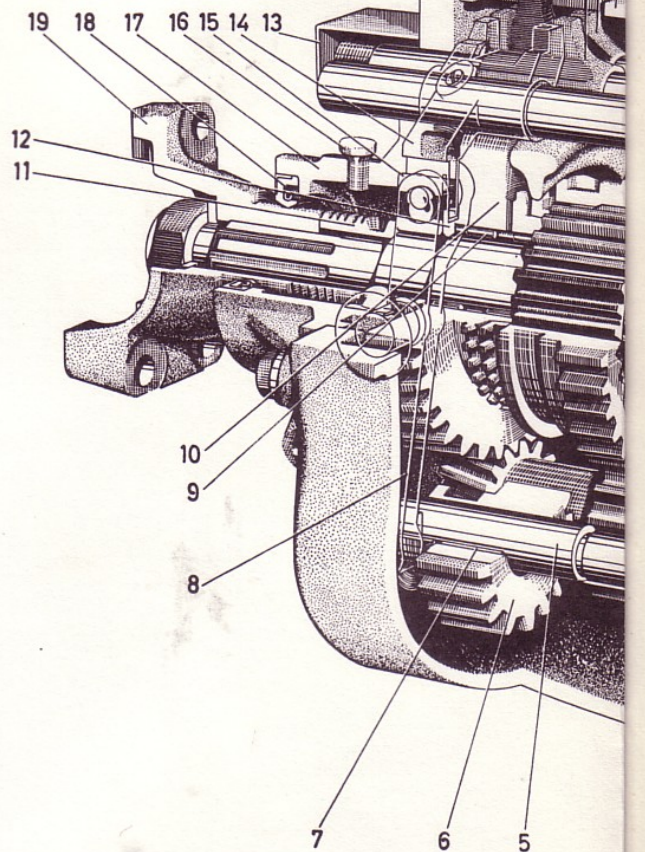
\*) Concerning lubricant and oil capacity for gearboxes with overdrive, see "P, Part 4 (43), Overdrive"

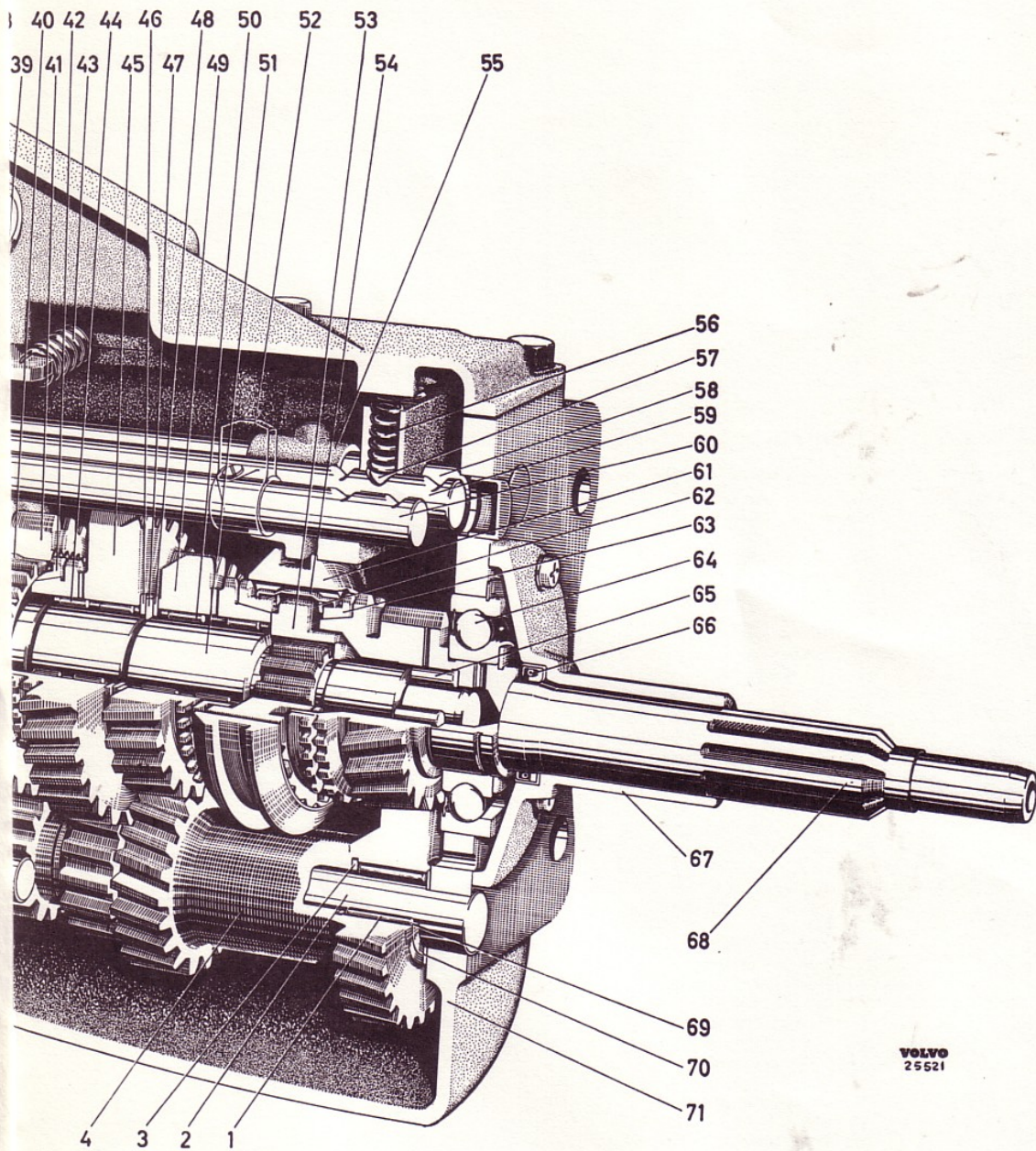




**Illustration A. M 40 Gearbox**

- |  |   |
|--|---|
| 1. Needle bearing                        | 38. Guide for 3rd and 4th speed gear wheels |
| 2. Idler gear shaft                      | 39. Sliding plate                           |
| 3. Spacing washer                        | 40. Guide                                   |
| 4. Idler gear                            | 41. Engaging sleeve and reverse gear wheel  |
| 5. Reverse gear shaft                    | 42. Synchronizing cone                      |
| 6. Reverse gear                          | 43. Spring                                  |
| 7. Bushing                               | 44. Needle bearing                          |
| 8. Lever                                 | 45. 2nd speed gear wheel                    |
| (X-ray illustration)                     | 46. Thrust washer                           |
| 9. Needle bearing                        | 47. Locking ring                            |
| 10. 1st speed gear wheel                 | 48. Thrust washer                           |
| 11. Speedometer gear                     | 49. 3rd speed gear wheel                    |
| 12. Thrust washer                        | 50. Needle bearing                          |
| 13. Casing                               | 51. Main shaft                              |
| 14. Carrier                              | 52. Carrier for reversing light switch      |
| (X-ray illustration)                     | 53. Synchronizing hub                       |
| 15. Ball bearing                         | 54. Guide                                   |
| 16. Air-venting nipple                   | 55. Selector fork for 3rd and 4th speeds    |
| 17. Rear cover                           | 56. Spring                                  |
| 18. Sealing ring                         | 57. Interlock ball                          |
| 19. Yoke                                 | 58. Selector rail for 3rd and 4th speeds    |
| 20. Carrier                              | 59. Selector rail for 1st and 2nd speeds    |
| 21. Bushing                              | 60. Selector rail for reverse               |
| 22. Spring                               | 61. Engaging sleeve                         |
| 23. Knob                                 | 62. Spring                                  |
| 24. Gear lever                           | 63. Synchronizing cone                      |
| 25. Sleeve                               | 64. Ball bearing                            |
| 26. Reverse catch                        | 65. Roller bearing                          |
| 27. Washer                               | 66. Seal ring                               |
| 28. Spring                               | 67. Cover                                   |
| 29. Bearing seat                         | 68. Input shaft                             |
| 30. Ball cup, upper                      | 69. Spacing washer                          |
| 31. Ball cup, lower                      | 70. Thrust washer                           |
| 32. Bearing cage                         | 71. Housing                                 |
| 33. Bushing                              |   |
| 34. Shaft                                |   |
| 35. Cover                                |   |
| 36. Selector                             |   |
| 37. Selector fork for 1st and 2nd speeds |   |





**VOLVO**  
 25521



Printed in Sweden, Gotab, Surte 70.5158