

Volvo Part Number 7777944-5

VOLVO

Rear Axle

- Road Test
- In-Car Repairs
- Disassembly
- Assembly



A GOOD ROAD TEST MUST BE DONE
BEFORE YOU BLAME NOISE ON THE REAR AXLE

Produced By:

Volvo of America Corporation

NATIONAL SERVICE SCHOOL

Rear Axle Department

Rockleigh, N.J. 07647

This book cannot be cited for warranty claims.

Volvo Part Number 7777944 - 5

©Copyright Volvo of America Corporation, 1973

Price: \$1.00

TABLE OF CONTENTS

ROAD TEST

PAGE

Road Test and Maintenance	2
Introduction to Book Format	5

IN-CAR REPAIRS

Replacing Bearing and Seals on Axle Shaft	6
Replacing Oil Seal on Pinion	9

OVERHAUL

Tool and Material List	13
Removing Rear Axle	15
Disassembling Rear Axle	17
Disassembling Differential	22
Inspecting Rear Axle	24
Assembling Differential	26
Installing Pinion	28
Installing Differential	36
Assembling Rear Axle	43
Installing Rear Axle	45

NOTE

In this book, the rear axle is the entire casing, differential, axle shafts and bearings.
The differential is a part of the rear axle.

ROAD TEST AND MAINTENANCE

Normal Maintenance

Check Oil Level in Rear Axle every 6,000 miles. Oil level should be up to the hole.

Add oil as necessary. Not over hole, let excess drain! Use MIL-L-2105B SAE 90 (on limited slip models use MIL-L-2105B SAE 90 with additive for limited slip).

Check rear axle cover, pinion and axle shaft seals for leaks.



Road Test for Ring and Pinion, Bearings, or Other Looseness

Special Note: Rear axle and differential must be at normal operating temperature for road test. Thick oil may hide noises.

Ring and Pinion Noise

Noise in test 1 OR 2.

There is a good reason to believe that this axle can be adjusted. The contact pattern between ring and pinion will decide. See steps 93 through 96.

Noise in Both Test 1 and 2.

Upon dismanteling, a gear contact pattern should be taken. See steps 93 through 96. We do not wish to replace a gear set if the noise is caused by other components. Replace if defective.

Bearing Noise in Differential

A bearing whine is usually different from a gear whine. Bearing whine is independent of load. If you maintain speed but change up on the gas pedal, there is a continuous hard noise.

Wheel Bearing Noise

Wheel bearings can make noise like the differential. However turning left or right under load should cause the noise to change.

Other Looseness Like Cluck or Croak, Clang and Bang

The noise that occurs under low or no load driving such as clucking and croaking cannot always be blamed

on the gear set. Such noise can come from

- a. Spider gears too sloppy in the carrier housing.
- b. Axle shaft spines too loose in the spider gears.
- c. Axle and float excessive.
- d. Incorrect lubricant being used.
- e. Too loosely adjusted pinion bearings.
- f. Excessive drive line slack.

Unusual Causes of Noise

Roof rack or ski rack wind noise can sound just like axle and bearing noise. If you suspect the rack, remove it and re-test.

Worn clutch disk center in manual transmission can transmit engine pulse noises to the rear axle during constant speed, or constant light load/no load condition.

Customer driving habits, improper car use etc. can produce noise which you can not find on a road test. Ask the customer to show you the noise. Fasten your seat belt!

NOTES

The column below tells in detail how the work is done.

The photo shows how to do it.

Open the fold-out sheet at the end of the book as you do the work step-by-step.



The numbers in parenthesis refer to the photo or drawing and the fold-out sheet.



IN-CAR REPAIRS

Numbers in () refer to fold-out parts drawing.

These are the only repairs that can be done with the unit in the car.
Any other repair must be done after the unit is removed from the car.

REPLACING BEARING AND SEALS ON AXLE SHAFT

- Jack up car. Place supports under rear axle. Remove wheels.
- Disconnect brake hose. Remove brake caliper and disc. See Section 5 of Service Manual.

REPLACING BEARING AND SEALS ON AXLE SHAFT

Jack up car.
Disconnect brake hose.
Remove brake caliper and disc.

1

NOTE: Numbers in steps 2, 4, 5, 6, and 8, refer to drawing on page 16.

- Remove bolts (7) thru plate (6). Use 9/16 inch socket. Use hole in axle shaft flange to remove bolts.
- Attach puller 2709 to flange. Pull out axle shaft (2).



Pull out axle shaft.
(2)

2

On rear axles with inner seal (A) use puller 4030 to remove seal.

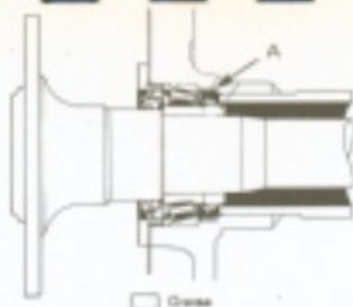

Pull out inner seal.

3

- Place tool 2838 in vice. Place axle shaft in tool so that tool arms are around bearing.
- Attach flange of axle shaft to spindle of tool. Screw out spindle to pull bearing (4) and ring (3) off shaft.
- Remove oil seal (5).



Pull bearing, ring, and oil seal off shaft. (4,3,5)

4

- Fill space between lips on new seal (5) with grease.
- Place seal on shaft.
- Place bearing (4) and ring (3) on shaft as shown.



Install oil seal on shaft. (5)

(5)

- Place fitting ring 5010 against bearing and ring. Close arms of tool around fitting ring. Lock arms.
- Turn spindle to press bearing (4) and ring (3) on shaft. Make sure bearing is seated.
- Remove shaft from tool.

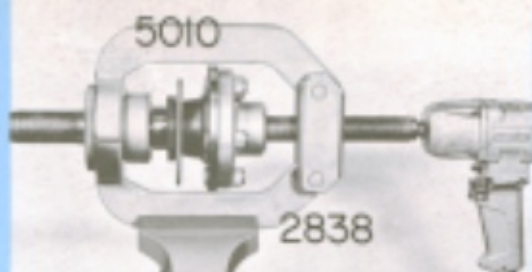

Press bearing and ring on shaft. (4,3)

8

On rear axles which have inner seals, grease inner seal. Push seal into rear axle. Use pusher 5009 and handle 1801.

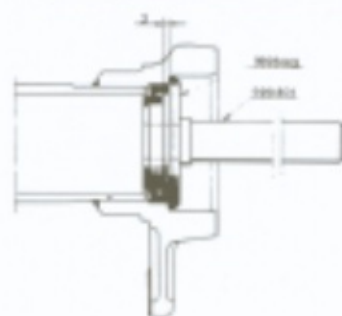

Install inner seal.

7

- Grease bearing. Place axle shaft in rear axle.
- Install bolts (7) thru plate (6) into rear axle.
- Torque bolts to 36 foot-pounds. Use 9/16 inch socket and torque wrench.

Install axle shaft in rear axle.
Torque- 36 foot-pounds.

8

- Install brake disc and caliper. Connect brake hose. Bleed and adjust brakes. See Section 5 of Service Manual.
- Install wheels. Remove supports. Lower car. Tighten wheel nuts.

Install brake disc and caliper. Install wheels.

9

REPLACING OIL SEAL ON PINION

- Jack up car. Place supports under rear axle.
- Disconnect rear section of drive shaft from flange on rear axle.

REPLACING OIL SEAL ON PINION

Disconnect drive shaft from rear axle.

10

- Check pinion for looseness on bearing. If loose, remove rear axle for repair.
- Install tool 2837/2854 on flange. Use 2837 for cars with B20 E and B30 F. Use 2854 for cars with B20 A, B, or F.
- Remove nut (25) and washer (24) holding flange. Use 1 1/8 inch socket and breaker bar.



Remove nut and washer holding flange. (25,24,37/39)

- Attach puller 2261 to flange.
- Pull flange (37/39) off. Use 18mm socket on tool.



Pull flange off.
(37/39)

12

Place puller 4030 in pinion opening so that it hooks onto seal. Pull seal (35) out.

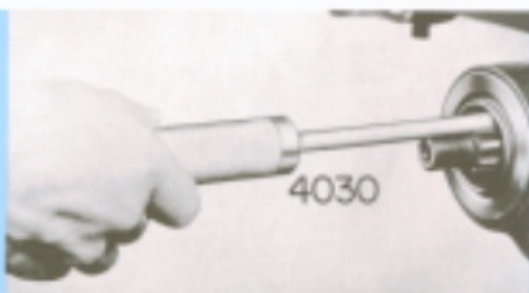

Pull seal out.
(35)

13

- Coat lips and spring coil of new seal (35) with grease.
- Place seal on tool 2806. Push seal into rear axle.

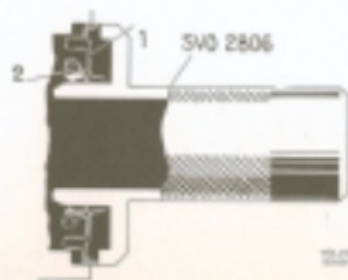

Install seal.
(35)

14

- Place flange (37/39) on pinion. Press flange down. Use tool 1845.
- Hold flange with tool 2837/2854.
- Place nut (25) and washer (24) on pinion.
- Torque nut at 200 to 220 foot-pounds. Use 1 1/8 inch socket and torque wrench.



Install flange,
washer and nut.
(37/39,24,25)
Torque- 200 to 220
foot-pounds.

15

- Connect drive shaft to flange.
- Remove supports. Lower car.
- Check oil level in rear axle.

Connect drive shaft
to flange.

16



1801



1845



2261



2284



2392



2393



2394



2395



2404



2483



2595



2597



2598



2599



2600



2685



2686



2709



2806



2837



2838



2839



2841



4030



4112

TOOL AND MATERIAL LIST

Special Tools

999 (SVO)

1801 Standard handle
1845 Flange press
2261 Flange puller
2284 Dial indicator retainer
2392 Pinion bearing puller
2393 Pinion measuring tool
2394 Expander
2395 Pinion bearing sleeve
2404 Pinion bearing tool
2483 Carrier bearing puller
2520 Stand
2522 Rear axle fixture
2595 Adjusting rings
2597 Crown wheel brake
2598 Rear pinion bearing drift
2599 Front pinion bearing drift
2600 Measuring fixture
2601 Holders for expander
2685/2840 Pinion adjusting ring
2686/2845 Pinion bearing press ring
2709 Axle shaft puller
2714 Rear axle fixture
2806 Oil seal tool
2827/2854 Counter hold for flange

2838 Axle shaft bearing press
5010 Axle shaft bearing ring
2841 Adjusting ring spanner
4030 Oil seal puller
4112 Carrier bearing drift
5009 Driver for inner seal

Material

Grease
Brake fluid
White lead
Solvent
Wooden block
Engine oil
Final drive oil

Hand Tools

Garage jack
Supports
Micrometer
Feeler gauge
Hammer
Dial indicator
Common screwdriver
Wrench-11/16", 21mm
Drift pin-1/4"
Extremely fine emery cloth
Breaker bar-1/2" drive
Vice with protected jaws
Torque wrench-foot-pounds
Torque wrench-inch-pounds
Sockets-5/8", 9/16", 1 1/8", 18mm
Batchet 1/2" drive

NOTES

REMOVING REAR AXLE

- Block front wheels. Loosen rear wheel nuts.
- Jack up rear end of car. Use tool 2714 and garage jack.

CAUTION

In the next step, do not place supports further than indicated by dash line.



REMOVING REAR AXLE

Place tool 2714 and garage jack under rear axle.

17

NOTE: Numbers in steps 18,19 and 20 refer to drawing of page 16

- Place supports in front of rear jack attachments. Lower jack slightly.
- Disconnect shock absorbers (42,43) at top.



Place supports under car.

18

- Disconnect parking brake. See Section 5 of Service Manual. Remove union for brake line from axle casing.
- Remove bolts holding drive shaft to flange. Loosen bolts (15) on support arms (13) 1 turn. Remove bolts (26) holding torque rods (20) to axle casing.

Remove rear axle.

19

- Remove nut (33) and washer (32) holding rod (28) to axle casing. Pull rod off. Remove bolts (60) thru bottom of springs (53).
- Lower jack until support arms are free of springs. Remove bolts (18) holding arms to casing.
- Lower jack. Pull rear axle out the rear end.

Remove rear axle
(continued)

20

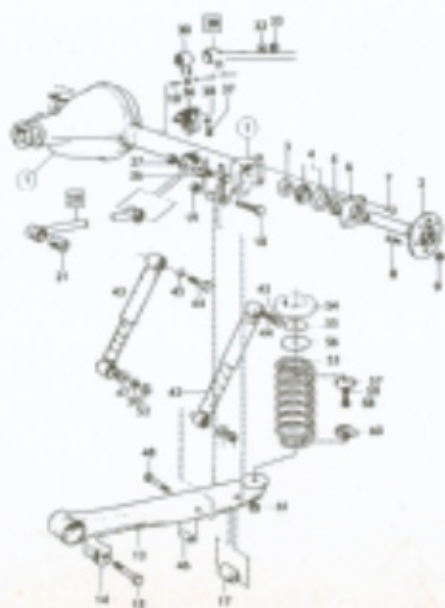

DISASSEMBLING REAR AXLE

- Place rear axle (2) in fixture 2522 on stand 2520. Place axle so that pinion is down with bottom of axle next to stand.
- Remove brake calipers and discs. See Section 5 of Service Manual.



DISASSEMBLING REAR AXLE

Place rear axle in fixture. Remove brake calipers and discs.

21

- Remove bolts thru plate. Use 9/16 inch socket. Use hole in axle shaft flange to remove bolts.
- Attach puller 2709 to flange. Pull out flange.

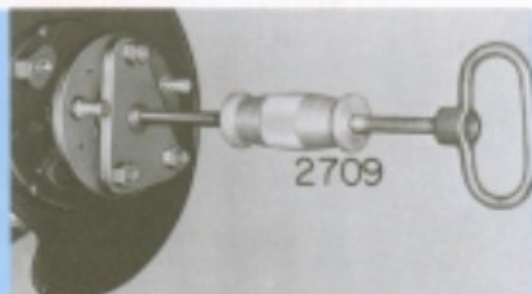

Remove axle shafts. (2)

22

On rear axles with inner seals for axle shafts, pull out seals. Use puller 4030.

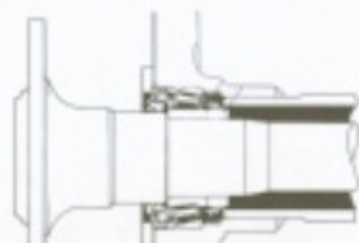

Remove inner seals for axle shafts.

Remove bolts (11) holding cover.
Remove cover (8) and gasket (10).



Remove cover,
(8)

24

If axle is being repaired because of noise, do the following:

- Clean teeth of crown wheel. Use solvent.
- Mark teeth at three places around wheel. Use white lead.



If axle is being re-
paired because of
noise, check tooth
pattern.

25

- Turn pinion 10 to 12 turns in both directions.
- Compare tooth pattern with those shown in steps 80 to 83 under Installing Differential.



Compare tooth pattern
with those shown in
steps 80 to 83.

26

- Check that cap (3) and carrier (13) are marked for alignment. If no markings or if marks are difficult to see, mark one side. Use a punch.
- Remove bolts (4) thru caps (3). Use 5/8 inch socket. Remove caps.



Remove caps.
(3)

27

- Place tool 2394 with 2601 on casing. Align pins on tool with holes in casing.
- Screw retainer bolts into casing.



Install tool 2394 on casing.

28

- Tighten bolts on tool until tool fits exactly in holes. Tighten bolt slightly until differential can be removed. Do not exceed 3 1/2 turns on bolt.
- Lift out differential (12) and crown wheel (21).
- Remove tool 2394.
- Release bolt after the differential and crown wheel have been removed.



Lift out differential and crown wheel out (12,21)

29

- Turn axle over. Drain oil.
- Install tool 2837/2854 on flange. Use 2837 on cars with B20 E or B30 F. Use 2854 on cars with B20 A, B, or F.
- Remove nut (25) and washer (24). Use 1 1/8 inch socket and breaker bar.



Remove nut and washer holding flange. (25,24,37/39)

30

- Attach puller 2261 to flange (37/39) with 4 bolts and nuts.
- Pull flange off. Use 18mm socket on tool.



Remove flange. (37/39)

31

Tap pinion (21) out. Use a wooden block to protect end of pinion.



Remove pinion. (21)

32

Place drift 2599 in front bearing (32,33) for pinion. Drive out bearing, shims (34) oil deflector (38/40), and oil seal (35).

- Catch parts as they come out.



Remove front bearing, shims, oil deflector, and oil seal. (32,33,34,38/40,35)

33

- Check bearing cup (32) for damage, burrs, or excessive wear.
- If necessary to remove bearing cup, turn casing over. Drive out bearing cup and shims (34). Use drift 2598 and handle 1801. Catch parts as they come out.



Remove bearing cup, necessary. (32)

34

Place tool 2392 over pinion. Press tool down until grooves in tool are over rollers. Pull up on bolt until grooves catch on rollers. Press lock ring down on tool. Make sure grooves catch on rollers.



Install tool 2392 on pinion.

Place tool in vice. Pull up on tool until bearing (33) is off pinion. Use 21mm wrench on tool.



Remove bearing.

36

DISASSEMBLING DIFFERENTIAL

NOTE: On rear axles with guard plate (A), do step 40 first. Then do steps 38 and 39. On rear axles without guard plate, do steps in order.

- Place differential in vice. Make sure vice has protected jaws.



DISASSEMBLING DIFFERENTIAL

37

- Remove bolts (22) and washers (23), axles without plate) holding crown wheel to carrier. Use 11/16 inch wrench. Remove crown wheel (21).

NOTE: If crown wheel is tight, thread bolts in part way. Tap bolts to push wheel off.



Remove crown wheel. (21)

38

- Drive lock pin (20) for shaft (19) out. Use drift pin.
- Drive shaft (19) for gears (15,16) out. Use drift pin.
- Turn both side gears (16) until pinion gears (15) are free. Remove side gears and washers (17,18).



Remove shaft, gears,
and washers.
(19,15,16,17,18)

39

- Place puller 2483 over bearing (26) on crown wheel side of carrier. Make sure groove in tool catches on rollers. Press lock ring down on tool.
- Tighten puller until bearing is off carrier. Repeat for other bearing. Do not lose shims.



Remove carrier
bearings.
(26)

40

INSPECTING REAR AXLE

- Thoroughly wash all parts except seals in solvent. Replace seals and gaskets.
- If you must reuse seals, wash them in water soluble solution. Solvent will damage seals.



INSPECTING REAR AXLE

Wash all parts.
Replace seals and gaskets.

41

- Inspect all gears and pinions for damage to teeth. The most common damage is seizing gear teeth.
- Inspect splines on pinion and side gears for nicks, burrs, and damage.
- Replace any damaged gears or pinions.



Inspect gears and pinions.

42

- Inspect all bearings cones and cups for wear, burrs, scratches, or damage.
- Inspect bearing rollers and retainers for damage.
- Replace any damaged bearing cones or cups.



Inspect bearing cups and cones.

43

- Inspect area of flange that contacts oil seal. If area is worn or scratched, replace flange and oil seal.
- Inspect spline inside flange. Replace flange if damaged.



Inspect flange.

44

- Inspect oil seal for damage, wear, or deformation. Inspect spring inside seal for damage.
- Replace seal if damaged.



Inspect oil seal.

45

- Inspect rear axle casing for cracks.
- Inspect brackets and stud for track rod for damage.
- Inspect stud thread for damage.
- Replace stud or casing if damaged.



Inspect casing.

46

25

ASSEMBLING DIFFERENTIAL

- Make sure all parts are clean. Use new bolts for gears.
- When measuring bearing clearance or pre-loading, oil bearing. Rotate bearing several turns under load.

- Place thrust washers (17) on side gears (16). Place gears in carrier (13).
- Line up pinions (15) with side gears. Place thrust washers (18) under pinions.
- Roll both gears until pinions are in place.

- Place shaft (19) in hole in carrier.
- Align hole in shaft with hole for lock pin in carrier. Make sure pinion gears are in line with shaft.
- Drive shaft in. Be careful that lock pin holes stay in line.

ASSEMBLING DIFFERENTIAL

Clean parts.

47

Install side and pinion gears with washers in carrier. (15,16,17,18,13)

48

Install shaft for pinion gears. (19)

49

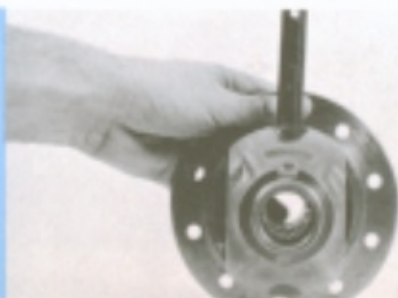

- Push side gears in toward center of differential. Measure clearance under side gear. Use a feeler gauge.
- Repeat for other side gear.
- If clearance exceeds 0.06mm (0.0024 inch) replace washers with thicker ones.



Check play of side gears.
Play- 0.06mm
(0.0024 inch)
max.

50

NOTE: Washers are available in thickness from 0.74 to 0.98mm (0.029 to 0.039 inch). Difference between each is 0.04mm (0.0016 inch).

NOTE: In the next step use a axle shaft to check torque. Cut shaft and adapt to it a torque wrench.

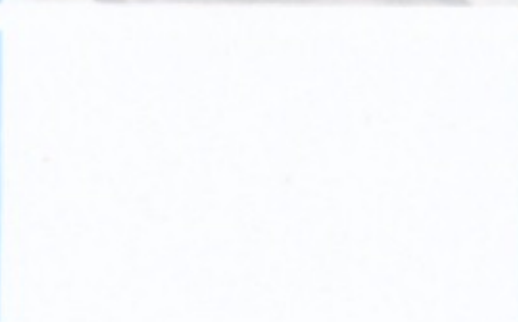

51

- If oversize washers are used, check torque needed to turn gear 1 turn.
- Torque should not exceed 7 foot-pounds.



Check torque needed to turn gears.
Torque- 7 foot-pounds.

52

- Make sure holes in shaft and carrier are in line. Drive lock pin (20) in until it is just below top of carrier.
- Place carrier in vice with protected jaws.



Drive lock pin in.
(20)

53

- Clean crown wheel and carrier surfaces.
- Place wheel (21) on carrier. Install bolts (22) and washers (23, differential without guard plate). Tighten bolts to pull wheel onto carrier.
- Torque-bolts at 45 to 60 foot-pounds. Use 11/16 inch socket and torque wrench.



Install crown wheel on
carrier.
(21)
Torque-45 to 60 foot-
pounds.

54

INSTALLING PINION

- Clean top surface of pinion. Use extremely fine emery cloth.
- Clean surface of casing for cover. Use extremely fine emery cloth.
- Clean areas for pinion bearing and carrier bearings inside casing.



INSTALLING
PINION

Clean casing.

55

- Place adjusting ring 2685/2840 on pinion (21). Make sure lock screw is up.
- Place tool 2841/2684 over pinion. Thread bottom of tool on pinion.
- Check that lugs on tool 2841/2684 are in grooves on ring.

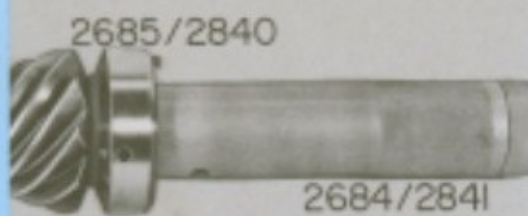

Place ring 2685/2840 and tool 2841/2684 on pinion.

56

- Place pinion in casing. Make sure lock screw is on large side of casing.
- Make sure pin on bottom of ring is in groove in casing.
- Note markings on top of pinion.



Place pinion in casing.

57

Remove pinion gauge from inside measuring tool 2393. Place tool on surfaces for carrier bearings. Pull tool apart until it fits snug in casing. Tighten lock screw on tool. Place gauge on pinion.



Place measuring tool 2393 in casing.

29

- Place dial indicator in tool 2284. Lock indicator in place.
- Place tool 2284 on casing. Adjust indicator for zero against raised surface of measuring tool.

2284



Place dial indicator on casing. Zero indicator.

59

- Move tool 2284 over so that indicator is on gauge.
- Refer to marking on pinion. Turn tool 2841/2684 on pinion until indicator reads same as marking on pinion.
- Lock adjusting ring.

2284



Adjust ring on pinion to dimension noted on top of pinion.

60

NOTE: Volvo parts are made on plus side. There is no plus or minus sign. The dimension is in hundredths of a millimeter. On other types, the marking may be plus or minus and are marked with + or - sign. The dimension is in thousandths of an inch.

61

Example: On Volvo parts, if marked 33, the gauge should be 0.33mm (0.013") below measuring tool. On other types, if marked +, the gauge should be below the tool. If marked -, the gauge should be above the tool.

- Remove tools from casing. Remove pinion. Remove ring from pinion.
- Place rear bearing cone (29) and cup (30) on fixture 2600 with cup up.
- Put plate, spring, and nut on fixture. Make sure flat side of nut is up.

- Turn plate and bearing several times so that rollers take up correct position.
- Place adjusting ring on fixture. Place tool 2284 and indicator on plate.
- Adjust indicator for zero against ring. Move indicator over outer ring of bearing.
- Note reading.



62

Set up tool 2600.

63

Measure adjusting ring and bearing.

Measure shim to obtain same dimension as noted on indicator. Use micrometer.

NOTE: You may not be able to find a shim with exact thickness. Shim must not be 0.03mm (0.0012") thicker nor 0.05mm (0.002") thinner than the measurement.



Measure shim to obtain shim equal to measurement.

65

- Place bearing (29) on pinion (21) as shown. Do not use washer under bearing (29).
- Place sleeve 2395 over pinion. Press bearing down. Make sure bearing is seated.
- Place shim (31) measured above in casing for rear bearing. Place cup (30) for rear bearing in casing.



Install rear bearing on pinion. (29)

66

- Place cup (32) for front bearing in casing.
- Pull both cups into casing. Use tool 2686/2845. Remove tool.
- Make sure both cups are seated. Use a feeler gauge to check under cups.



Install cups and shim in casing. (30,32,31)

67

- Place pinion (21) in casing. From front of casing, place three 0.75mm (0.03") shims on pinion. Place front bearing (32) on pinion.
- Place tool 2404 on pinion. Thread tool 1845 on pinion. Pull pinion in.

NOTE: If no thread shows thru tool, tap on tool until thread shows. Use plastic hammer. Then install tool 1845.



Install pinion with shims. (21)

68

- Remove tool 1845. Place washer (24) and nut (25) on pinion.
- Torque nut at 200 to 220 foot-pounds. Use 1 1/8 inch socket and torque wrench.

NOTE: If using compressed air, pull pinion toward you to seat rear bearing.



Install washer and nut. (24,25)
Torque 200 to 220 foot-pounds.

69

- Place pinion gauge of tool 2393 on pinion. Place tool 2284 with indicator on casing.
- Pull down on pinion while turning it forwards and backwards. Zero indicator while pulling down on pinion.
- Push up on pinion while turning it forwards and backwards. Note reading on indicator.



Measure pinion play.

70

- Remove nut (25) and washer (24) holding pinion. Use 1 1/8 inch socket.
- Tap out pinion. Use wooden block to protect end of pinion.



Remove pinion and front bearing.

71

- Remove shims equal to measured clearance plus 0.07mm (0.003").
- Place pinion in casing. Place remaining shims and bearing (32) on pinion.



Measure shims to pre-load pinion bearing. Pre-load—0.07mm (0.003 inch)

72

Place tool 2404 on pinion. Thread tool 1845 onto pinion. Pull pinion in. Remove tool 1845.
NOTE: If no thread shows thru tool 2404 tap on tool until thread shows. Use plastic hammer. Then install tool 1845.



Install tools 2404 and 1845 on pinion. Pull pinion in.

73

- Place nut (25) and washer (24) on pinion.
- Torque nut 200 to 220 foot-pounds. Use 1 1/8 inch socket and torque wrench.



Install nut and washer on pinion. (24,25)
Torque- 200 to 220 foot-pounds

74

- Check torque needed to turn pinion.
- On pinion with old bearings, torque should be 5 to 10 inch-pounds. On pinion with new bearings, torque should be 9 to 20 inch-pounds.
- Adjust shims under front bearing to meet requirements.

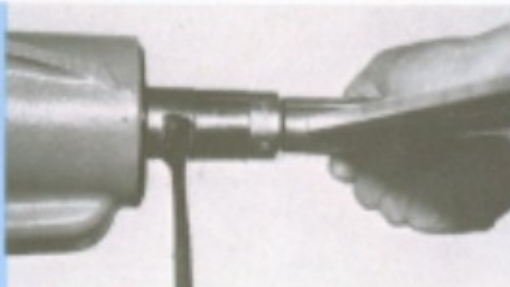

Check torque required to turn pinion.
Torque- 4 to 10 inch-pounds (old bearings)
9 to 20 inch-pounds (new bearings)

75

NOTE: On some new rear axles, torque may be higher due to another type of installation. This is still good.
Check location of pinion. Use tools 2393, 2284, and dial indicator. See steps 58 thru 60 in this book.



Check location of pinion. See steps 58 thru 60.

76

INSTALLING DIFFERENTIAL

- Coat inside of rings 2595 and bearing surfaces inside casing. Use engine oil.
- Place ring with black ring on side with crown wheel. Place other ring on other side of carrier.
- Place carrier with rings in casing.

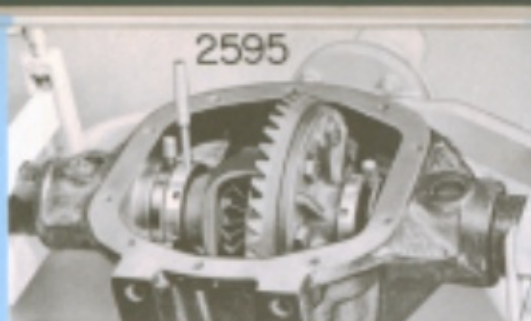

INSTALLING DIFFERENTIAL

Install tool 2595 on carrier.
(13)

77

- Set up dial indicator as shown.
- Hold pinion. Pull crown wheel toward indicator. Zero indicator.
- Push wheel away from indicator. Note reading on indicator. This is backlash.
- Adjust rings to obtain correct backlash of 0.15mm (0.006 inch).



Adjust backlash.
Backlash—0.15mm
(0.006 inch)

78

NOTE: Backlash can be from 0.005 inch (0.13mm) to 0.008 inch (0.20mm). But should be as close to 0.006 inch (0.15mm) as possible.

- Tighten lock screws on adjusting rings.

Tighten lock screws
on adjusting rings.

79

- Place brake tool 2597 on casing. Turn handle down to apply pressure to crown wheel.
- Mark several teeth on wheel at three places around wheel. Use white lead.
- Turn pinion 10 to 12 turns in both directions. Check contact marking pattern.



Check tooth contact marking pattern.

80

If pattern is horizontal in middle of tooth and nearer to toe than heel, pattern is correct.



Correct pattern.

81

If pattern is too far towards heel on driving side and too far towards toe on reverse side, the pinion should be moved inwards.



Incorrect pattern.
Move pinion inwards.

- If pattern is too far towards toe on driving side and too far towards heel on reverse side, the pinion should be moved outwards.
- If necessary, adjust position of pinion. Then repeat contact check.



Incorrect pattern.
Move pinion outwards.

83

- When backlash and contact pattern are correct, remove tool 2597.
- Remove differential. Remove adjusting rings from differential.

Remove tools and
differential.

84

- Place bearing (26) and cup (27) on fixture 2600 with cup up.
- Put plate, spring, and nut on fixture. Make sure flat side of nut is up.
- Turn plate and bearing several times so that rollers take up correct position.



Set up fixture 2600.

85

- Place adjusting ring on fixture. Place tool 2284 with indicator on tool.
- Adjust indicator for zero against ring.
- Move indicator over outer cup of bearing. Note reading.
- Remove bearing and ring. Place other bearing and ring in fixture. Repeat check.



Measure bearing and outer cup. (26,27)

86

- Make sure bearings are kept with their adjusting rings to show what side they go on.
- Add 0.07mm (0.003 inch) to first reading. Measure shims to this thickness. Use micrometer. Place shims with bearing.



Measure shims. (28)

Pre-load—0.07mm (0.003 inch)

87

Add 0.07mm (0.003 inch) to second reading. Measure shims to this thickness. Use micrometer. Place shims with bearings.



Measure shims for other bearing.

- On rear axles with guard plate, (A), place plate on differential housing.
- Make sure plate is in cutout in housing.



Place guard plate on differential housing

89

- Get bearing and shim with adjusting ring with black ring. Place shim (28) and bearing (26) on crown wheel side of casing. Press bearing on. Use drift 4112.
- Turn casing over. Place drift 2599 under bearing on carrier. Press bearing on. Use drift 4112.



Install shims, bearing and cups on carrier. (28,26,27)

90

- Place tool 2394 with 2601 on casing. Align pins on tool with holes in casing. Screw bolts into casing.
- Tighten bolt on tool until tool fits exactly in holes.
- Place carrier (13) and cups (27) in casing. Tighten bolt in tool until carrier will go into casing. Do not exceed 3 1/2 turns on bolt.



Install carrier in casing. (13)

91

- Remove tool 2394. Place caps (3) on carrier. Make sure markings on caps are on side of carrier with same markings.
- Install bolts (4) thru caps. Torque bolts at 36 to 50 foot-pounds. Use 5/8 inch socket and torque wrench.



Install caps with bolts.
(3,4)
Torque- 36 to 50 foot-
pounds.

92

- Check backlash and contact pattern as follows: Mark several teeth at 3 places around crown wheel. Turn pinion 10 to 12 turns in both directions.
- If pattern is horizontal in middle of tooth and somewhat nearer to toe than heel, pattern is correct.



Check backlash and
contact pattern.
Correct pattern.

93

- If pattern is above middle of tooth, backlash is excessive. Add shims under bearing on crown wheel side of carrier. Remove shims from other side.
- If pattern is below middle of tooth, backlash is too little. Remove shims from bearing on crown wheel side. Add shims to other side.



Incorrect pattern.
Adjust backlash.

If pattern is too far towards heel on driving side and too far towards toe on reverse side, pinion should be moved inwards.



Incorrect pattern.
Move pinion inwards.

95

- If pattern is too far towards toe on driving side and too far towards heel on reverse side, the pinion should be moved outwards.
- If necessary, adjust position of pinion or crown wheel. Then repeat check. Clean teeth of crown wheel and pinion.



Incorrect pattern.
Move pinion outwards.

96

ASSEMBLING REAR AXLE

- Remove nut and washer holding tool 2404 on pinion. Remove tool.
- Place oil deflector (38/40) on pinion. Coat lips and spring coil of seal with grease.
- Place oil seal (35) on drift 2806. Push oil seal into casing (2).

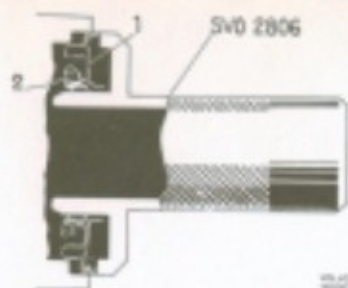

ASSEMBLING REAR AXLE

Install oil deflector and oil seal on pinion (38/40,35)

97

- Place flange (37/39) in casing (2).
- Thread tool 1845 on pinion. Tighten tool to press flange in. Remove tool.
- Make sure flange extends about 1.43 inches above casing.



Install flange on pinion. (37/39)

98

- Install tool 2837/2854 on flange.
- Place washer (24) and nut (25) on pinion.
- Torque nut at 200 to 220 foot-pounds. Use 1 1/8 inch socket and torque wrench. Remove tool.



Install washer and nut on pinion. (24,25)
Torque-200 to 220 foot-pounds.

99

Place new gasket (10) and cover (8) on casing. Install and evenly tighten bolts (11).



Install inspection cover and gasket. (8,10,11)

100

- On rear axles with inner seals, push new seals into axles. Use driver 5009 and handle 1801.
- Place axle shaft in casing. Align splines. Install bolts (7) thru plate (6). Torque bolts at 36 foot-pounds. Use 9/16 inch socket and torque wrench. Repeat for other side.

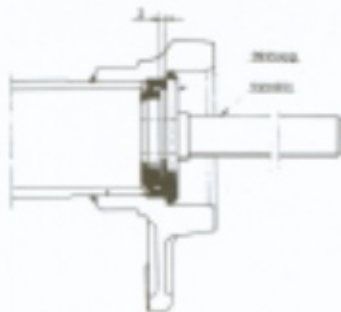

Install inner seals. Install axle shafts. Torque-36 foot-pounds.

101

- Install brake calipers and discs.
- Correct brake line. See Section 5 of Service Manual.

Install brake calipers and discs.

102

INSTALLING REAR AXLE

NOTE

Numbers in () in steps 103 thru 107 refer to picture at the bottom of this page.
Place axle on fixture 2714 on jack. Move axle in under car. Align brackets on axle with support arms and axle.

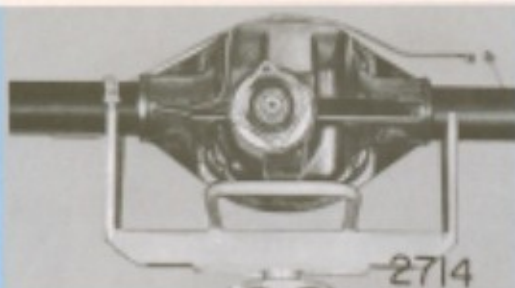

INSTALLING REAR AXLE

Position axle under car. Attach support arms.

103

Raise jack until support arms can be attached to springs (53). Install bolts (60) and nuts (61) thru bottom of spring.

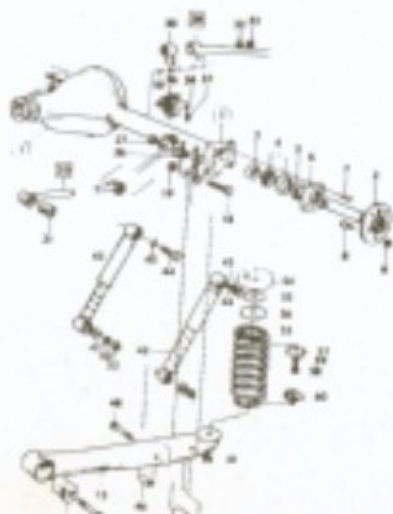

Attach springs.

104

- Raise jack until track bar (28) can be placed on stud on axle. Install washer (32) and nut (33).
- Install bolts (26) and nuts (27) thru torque rods (20) and axle. Tighten nuts (27).
- Connect shock absorbers (42,43) at top. Tighten bolts (44).

- Connect drive shaft to flange. Tighten bolts and nuts.
- Install union for brake line on casing.
- Adjust parking brake and bleed brakes. See Section 5 of Service Manual.

Fill rear axle with new oil. Use MIL-L-2105B SAE 90.

NOTE: Change oil in new or rebuilt rear axle after first 1500 miles. Make sure oil is warm before draining. Clean drain plug.

Attach torque rods, track bar, and shock absorbers.
(28,32,33,26,27,42,43,44,45)

105

Connect drive shaft.
Connect brakes.

106

Fill rear axle with oil.

107

1
2
3
4
5
6
7
8
9
10
11
12
13
14
15
16
17
18
19
20
21
22
23
24
25
26
27
28
29
30
31
32
33
34
35
36
37
38
39
40
41
42
43
44
45
46
47
48
49
50

DRAFT COPY - NOT FOR USE

1 REAR AXLE

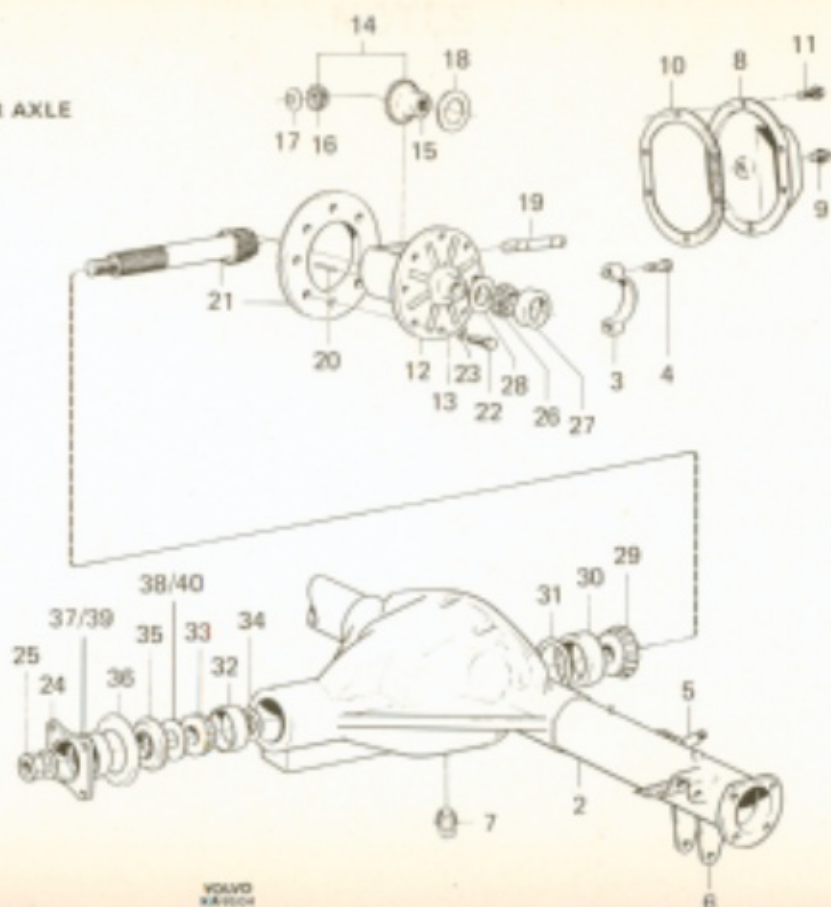

VOLVO
KA9004

KEY FOR FOLD OUT PARTS DRAWING

- | | |
|------------------------|----------------------------|
| 1. Rear axle | 21. Pinion and crown wheel |
| 2. Casing | 22. Bolt |
| 3. Cap | 23. Resilient washer |
| 4. Bolt | 24. Washer |
| 5. Stud | 25. Nut |
| 6. Bracket | 26. Roller bearing cone |
| 7. Plug | 27. Roller bearing cup |
| 8. Cover | 28. Thrust washer |
| 9. Plug | 29. Roller bearing cone |
| 10. Gasket | 30. Roller Bearing cup |
| 11. Bolt | 31. Shims |
| 12. Differential | 32. Roller bearing cup |
| 13. Carrier | 33. Roller bearing cone |
| 14. Differential gears | 34. Shims |
| 15. Pinion gear | 35. Oil seal |
| 16. Side gear | 36. Dust slinger |
| 17. Thrust washer | 37. Flange |
| 18. Thrust washer | 38. Oil deflector |
| 19. Shaft | 39. Flange |
| 20. Pin | 40. Oil deflector |