

CONTENTS

GROUP 20 GENERAL

Data	1
Special tools	7
Description	9

GROUP 21 ENGINE BODY

Description	1
Service Procedures (concerns engine in vehicle, unless otherwise indicated)	2
Engine	2
Removing	2
Disassembling	4
Assembling	5
Installing	7
Cylinder head	8
Removing	8
Checking surface unevenness	8
Installing	8
Valve mechanism	10
Valve clearance, adjusting	10
Valve tappets, replacing	10
Valve guides, replacing	10
Valve and valve seats, grinding	11
Rocker arm mechanism	12
Disassembling and checking	12
Assembling	12
Cylinder block	12
Cylinder liners, measuring	12
Pistons and connecting rods	13
Removing	13
Piston fit and pistons, measuring	13
Piston rings, replacing	13
Gudgeon pins and gudgeon pin bushings, replacing	14
Installing	15
Crankcase ventilation (inspection)	15
Timing gears	16
Timing gear casing	16
Sealing ring, replacing	16
Removing	17
Installing	17
Timing gears, replacing	17
Camshaft	18
Checking the wear, engine in vehicle	18
Removing and checking	19
Installing	19
Camshaft bearing, replacing	20
Crank mechanism	20
Crankshaft	20
Rear seal, replacing	20
Removing	21
Checking	21
Grinding	21
Installing	22
Flywheel, grinding	22
Input shaft support bearing, replacing	23
Engine mounts	23
Rear, replacing	23
Front, replacing	23

GROUP 22 LUBRICATING SYSTEM

Description	1
Service Procedures	3
Oil pump	3
Removing	3
Checking and reconditioning	3

Installing	4
Oil cooler, replacing	4
Oil filter, replacing	4

GROUP 23 FUEL SYSTEM

Description	1
Service Procedures	8
Carburettors	8
Periodical checking	8
Adjusting	8
Without Co-meter	8
With CO-meter	9
Measures with faulty carburettor function	10
Fuel jets, adjusting	11
Secondary throttle, checking	12
Removing	12
Diaphragm, replacing	12
Fuel jets, replacing	13
Metering needle, replacing	13
Floatchamber, cleaning	14
Float level	14
Temperature compensator, replacing	15
Throttle spindle, re-bushing	15
Installing	16
Air cleaner, insert, replacing	16
Fuel pump, cleaning	16
Fuel tank	17
Removing	17
Installing	17

GROUP 25 INTAKE AND EXHAUST SYSTEM

Description	1
Service Procedures	1
Manifold	1
Removing	1
Installing	1
Exhaust system	2
Removing	2
Installing	2

GROUP 26 COOLING SYSTEM

Description	1
Service Procedures	3
Coolant, topping-up	3
Coolant, draining	3
Cooling, filling (empty system)	3
Pressure-testing cooling system	3
Radiator	3
Removing	3
Installing	4
Coolant pump, replacing	4
Thermostat, testing	5
Drive belts, replacing	5
Fan drive	5
Removing fan and bearing bracket	5
Cooling fan, replacing	5
Fan journalling, replacing	6
Installing fan and bearing bracket	6

GROUP 27 ENGINE CONTROLS

Description	1
Service Procedures	1
Throttle control, adjusting	1

Illustration 2 A Engine

GROUP 20 GENERAL

Data

GENERAL

Type designation	B 30 A - 498211
Max output, kW at r/s DIN	86/67
h.p. at r/m DIN	117/4 000
Max. torque, Nm at r/s DIN	206/42
kpm at r/m DIN	21/2 500
lbftf	152
Compression pressure (hot engine) when turned over with starter motor 4.2-5.0 r/s (250-300 r/m)	1 000-1 200 kPa (10-12 kp/cm ²) (142-170 lbf/in ²)
Compression ratio	9.3:1
Number of cylinders	6
Bore	88.9 mm (3.50")
Stroke	80 mm (3.15")
Displacement	2.98 dm ³ (litres)
Idle speed	11.67-13.33 r/s (700-800 r/m)

CYLINDER HEAD

Height, measured from cylinder head contact face to face for bolt heads	86.7 mm (3.413")
Distance from top side of head to overflow pipe upper end (pipe placed under thermostat)	35 mm (1.38")
Cylinder head gasket, thickness, unloaded	0.8 mm (0.031")
loaded	0.7 mm (0.028")

CYLINDER BLOCK

Material	Special alloy cast iron
Bore, mm (in.)	
Standard (D-marked)	88.91-88.92 mm (3.5004-3.5008")
"Oversize" 0.03 mm (0.0012")	88.94-88.95 mm (3.5016-3.5020")
Oversize 0.015"	89.29-89.30 mm (3.5153-3.5157")
Oversize 0.030"	89.67-89.68 mm (3.5303-3.5307")
The cylinders should be drilled with a wear of (if engine has abnormal oil consumption)	0.25 mm (0.010")

PISTONS

Material	Light alloy
Permissible weight difference between pistons in same engine	10 grammes (0.35 oz.)
Height, total	71 mm (2.79")
Height from piston pin centre to piston crown	46 mm (1.81")
Piston clearance	0.01-0.03 mm (0.0004-0.0012")
Diameter, right angles to gudgeon pin 7 mm (0.28") from lower edge of piston:	
Standard, D-marked	88.890-88.900 mm (3.4995-3.5000")
"Oversize" 0.0012"	88.928-88.930 mm (3.5008-3.5011")
Oversize 0.015"	89.267-89.282 mm (3.5144-3.5150")
Oversize 0.030"	89.647-89.662 mm (3.5294-3.5300")

C3-series

Piston rings

Piston ring gap, measured in ring opening	0.40–0.55 mm (0.016–0.022")
Oversize on piston rings	0.03 mm (0.0012")
	0.015"
	0.030"

Compression rings

Upper ring chromed	
Number on each piston	2
Height	1.98 mm (0.078")
Compression ring clearance in groove	0.040–0.072 mm (0.0016–0.0028")

Oil scraper rings

Number on each piston	1
Height	4.74 mm (0.186")
Scraper ring clearance in groove	0.040"–0.072 mm (0.0016–0.0028")

Gudgeon pins

Floating fit. Circlips at both ends on piston.	
Fit in connecting rod bushing	Close running fit (light thumb pressure)
Clearance, gudgeon pin-connecting rod bushing	0.0100–0.0135 mm (0.0004–0.0005")
Fit in piston	Slide fit (thumb pressure)
Clearance, gudgeon pin – piston	0.0035–0.0070 mm (0.00001–0.00003")
Diameter, standard	24.00 mm (0.945")
oversize 0.05 mm (0.002")	24.05 mm (0.947")

VALVE MECHANISM

Valves

Intake

Disc diameter	42 mm (1.654")
Stem diameter	7.955–7.970 mm (0.3132–0.3138")
Stem, max. permissible wear	0.02 mm (0.0008")
Valve seat angle	44.5°
Cylinder head seat angle	45.25°
Seat width in cylinder head	2 mm (0.08")

Exhaust

Disc diameter	35 mm (1.378")
Stem diameter	7.925–7.940 mm (0.3120–0.3126")
Stem, max. permissible wear	0.02 mm (0.0008")
Valve seat angle	44.5°
Cylinder head seat angle	45.25°
Seat width in cylinder head	2 mm (0.08")

Valve clearance

Clearance, hot and cold engine, exhaust	0.40–0.45 mm (0.016–0.018")
Clearance, hot and cold engine, intake	0.40–0.45 mm (0.016–0.018")

C3-series

Valve guides

Length, inlet valve	52 mm (2.047")
exhaust valve	59 mm (2.323")
Inner diameter	8.000–8.022 mm (0.3150–0.3158")
Height above upper face of cylinder head	17.5 mm (0.689")
Clearance, valve stem – valve guide, inlet valve	0.030–0.067 mm (0.0012–0.0026")
exhaust valve	0.060–0.097 mm (0.0024–0.0038")
max. permissible clearance	0.15 mm (0.006")

Valve springs

Length, unloaded, approx.	45 mm (1.77")
with a loading of 255±20N (25.5±2 kp = 56±4.4 lbf.)	39 mm (1.54")
with a loading of 660±35 N (66±3.5 kp = 145±7.7 lbf.)	30.5 mm (1.20")

Rocker arm mechanism

Rocker arm radius at valve end	12 mm (0.48")
Rocker arm bushing, max. permissible wear	0.1 mm (0.004")

CAMSHAFT TRANSMISSION

Timing gears

Crankshaft drive, number of teeth	28
Camshaft gear, number of teeth	56
Backlash	0.04–0.08 mm (0.0016–0.0032")
Max. permissible backlash	0.12 mm (0.0048")
End float, camshaft	0.02–0.06 mm (0.0008–0.0024")

Camshaft

Marking/max. lifting height	A/6 mm (0.24")
Number of bearings	4
Bearing journal, diameter	46.975–47.000 mm (1.8494–1.8504")
Max. permissible out-of-round (with new bearings)	0.07 mm (0.0028")
Radial clearance	0.020–0.075 mm (0.0008–0.0030")
End float	0.020–0.060 mm (0.0008–0.0024")
Valve clearance for checking camshaft setting (cold engine)	1.10 mm (0.043")
Intake valve should then open at	10° A.T.D.C.

Camshaft bearing

Bearing diameter	47.020–47.050 mm (1.8512–1.8524")
Max. permissible wear	0.02 mm (0.0008")

CRANK MECHANISM

Connecting rods

End float on crankshaft	0.15–0.35 mm (0.006–0.014")
Length, centre-centre	144.9–145.1 mm (5.70–5.71")
Max. permissible weight deviation between connecting rods in same engine	10 grammes (0.35 oz.)

C3-series

Crankshaft

Crankshaft end float	0.037–0.147 mm (0.0015–0.0058")
max. permissible end float	0.15 mm (0.0060")
Main bearings, radial clearance	0.028–0.083 mm (0.0011–0.0033")
Big-end bearings, radial clearance	0.024–0.070 mm (0.0009–0.0028")

Main bearings

Main bearing journals

Diameter, standard	63.451–63.464 mm (2.4981–2.4986")
undersize 0.010"	63.197–63.210 mm (2.4881–2.4886")
0.020"	62.943–62.956 mm (2.4781–2.4786")
Width on crankshaft for pilot bearing shell	
standard	38.960–39.000 mm (1.5338–1.5354")
oversize 1 (undersize shell 0.010")	39.061–39.101 mm (1.5378–1.5394")
2 (undersize shell 0.020")	39.163–39.203 mm (1.5419–1.5434")
Max. permissible out-of-roundness	0.05 mm (0.0020")

Main bearing shells

Thickness, standard	1.975–1.985 mm (0.0780–0.0781")
undersize 0.010"	2.102–2.112 mm (0.0827–0.0831")
0.020"	2.229–2.239 mm (0.0878–0.0881")

Big-end bearings

Big-end bearing journals

Width of bearing recess	29.95–30.05 mm (1.1779–1.1830")
Diameter, standard	53.987–54.000 mm (2.1255–2.1260")
undersize 0.010"	53.733–53.746 mm (2.1155–2.1160")
0.020"	53.479–53.492 mm (2.1055–2.1060")
Max. permissible out-of-round	0.07 mm (0.0028")

Big-end bearing shells

Thickness, standard	1.978–1.988 mm (0.0779–0.0783")
undersize 0.010"	2.105–2.115 mm (0.0829–0.0833")
0.020"	2.232–2.242 mm (0.0879–0.0883")

Flywheel

Minimum permissible thickness (after grinding)	29.7 mm (1.17")
Permissible axial throw, max.	0.05 mm (0.002")/150 mm (5.9") diameter
Ring gear (chamfer forwards)	153 teeth

LUBRICATING SYSTEM

Lubricating oil, type	See lubricating chart
Oil change quantity	5.2 litres (4.5 Imp. qts. = 5.5 US qts.)
incl. oil filter	5.7 litres (5.0 Imp. qts. = 6.0 US qts.)
Incl. oil filter and oil cooler	6.2 litres (5.5 Imp. qts. = 6.5 US qts.)
Oil pressure at 33 r/s (2000 r/m) (with hot engine and new oil filter)	250–600 kPa (2.5–6.0 kp/cm ² = 35–85 lbf/in ²)

Lubricating oil pump

Lubricating oil pump, type	Gear
number of teeth on each gear wheel	9
end float	0.02–0.10 mm (0.0008–0.0039")

Lubricating oil pump, radial clearance (between tooth crown and pump body)	0.08–0.14 mm (0.0032–0.0055")
backlash	0.15–0.35 mm (0.0060–0.0140")

Relief valve spring (in oil pump)

Length, unloaded	39 mm (1.54")
loaded with 50±4 N (5.0±0.4 kp = 11.0±8.8 lbf.) . .	26.25 mm (1.03")
70±8 N (7.0±0.8 kp = 15.4±1.7 lbf.) . .	21.0 mm (0.83")

Lubricating oil filter

Type	Full-flow
----------------	-----------

FUEL SYSTEM**Carburettors**

Type	Horizontal
Make and designation	Zenith-Stromberg 175 CD-2S E
Number	2
Air intake diameter	41.3 mm (1.63")
Metering needle designation	B2 BA
Idling speed	11.67–13.33 r/s (700–800 r/m)
CO-test	2.5%

Fuel pump

Diaphragm pump alt. 1	Pierburg PE 15695
alt. 2	SEV 200 050 12
Fuel pressure at 16.6–100 r/s (1000–6000 r/m) min	15 kPa (0.15 kp/cm ² = 2.1 lbf/in ²)
max.	28 kPa (0.28 kp/cm ² = 4.0 lbf/in ²)

Fuel filter

Make and designation	Carter F 827 S
--------------------------------	----------------

Fuel tank

Capacity, two-axle with wheelbase 2300 mm	125 litres
(90.5")	(27.5 Imp. gals. = 33.0 US gals.)
two-axle with wheelbase 2530 mm	150 litres
(99.6")	(33.0 Imp. gals. = 40.0 US gals.)
and three-axle	

COOLING SYSTEM

Type	Sealed system
Expansion tank valve (in cap) opens at	70 kPa (0.7 kp/cm ² = 10 lbf/in ²)
Capacity	10 litres (2,2 Imp. gals. = 2.6 US gals.)
Drive belts, designation	two HC-38x888

Thermostat

Type	Wax
Marked	82°
Starts opening at	79–83°C (175–182°F)
Fully open at	95°C (203°F)

TIGHTENING TORQUES

	Nm	Kpm	Lbftf
Cylinder head bolts (oiled) ¹⁾	90	9	65
Spark plugs	40	4	29
Main bearing bolts	120-130	12-13	87-94
Big-end bearing nuts	63-70	6.3-7.0	45-50
Flywheel bolts	65-70	6.5-7.0	47-50
Oil sump bolts	8-11	0.8-1.1	6-8
Camshaft gear nuts	130-150	13-15	94-108
Crankshaft pulley bolts	95-105	9.5-10.5	69-75
Nipple for oil cooler and filter	45-55	4.5-5.5	32-40
Oil cooler nuts	30-35	3.0-3.5	22-25
Manifold nuts	18-22	1.8-2.2	13-16

1)

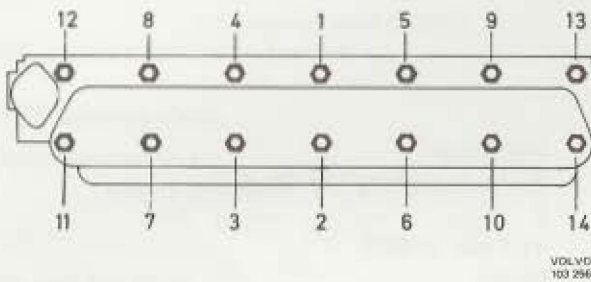

The cylinder head bolts should be tightened in three stages and according to the sequence illustrated here; step 1: 40 Nm (4 kpm = 29 lbftf), step 2: 80 Nm (8 kpm = 58 lbftf), step 3: after running the engine for about 10 minutes, allow the engine to cool and final-tighten the cylinder head bolts to 90 Nm (9 kpm = 65 lbftf).

Special tools

The following special tools are required for work on the engine

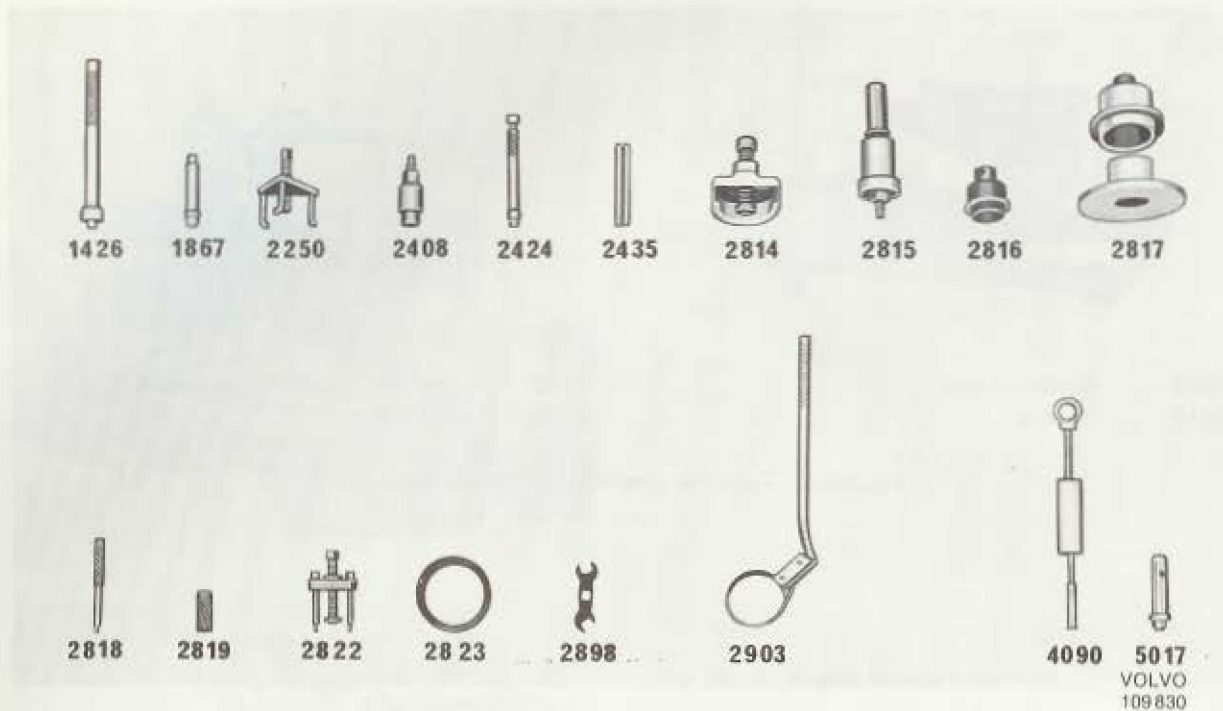

Fig. 20-1. Tools for work on engine

1426	Drift for fitting pilot bearing	2817	Drift for fitting crankshaft oil seal on engine rear end
1867	Drift for removing and fitting bushing in rocker arm	2818	Drift for pressing out valve guide
2250	Puller for camshaft gear	2819	Drift for pressing in valve guide
2408	Press tool for fitting camshaft gear	2822	Puller for crankshaft drive
2424	Grip tool for valve tappets	2823	Ring for fitting standard piston
2435	Dowel pins for fitting cylinder head	2898	Spanner for re-tightening cylinder head bolts
2814	Puller for polygon hub	2903	Tool for removing oil filter
2815	Press tool for fitting crankshaft drive and polygon hub	4090	Puller for crankshaft pilot bearing
2816	Drift for fitting crankshaft oil seal on engine front end	5017	Drift for removing and fitting bushing in connecting rod



9809 Workshop jack
9916 Fixture



6128 Spanner for speedometer wire
6129 Lifting lug

Fig. 20-2. Tools for removing and installing engine



Fig. 20-3. Stand for engine
2520 Stand. Used together with fixture 2820



Fig. 20-4. Carburettor tools

2402 Drift for throttle spindle bushing
2879 Fixture for carburettor housing
2880 Reamer for seat, throttle spindle bushing
2881 Reamer for throttle spindle bushing
2895 Press tool for pressing out fuel jet
2896 Gauge, placed between air valve and fuel jet
2897 Press tool for pressing down fuel jet
2962 Drift for pressing out fuel jet

Description

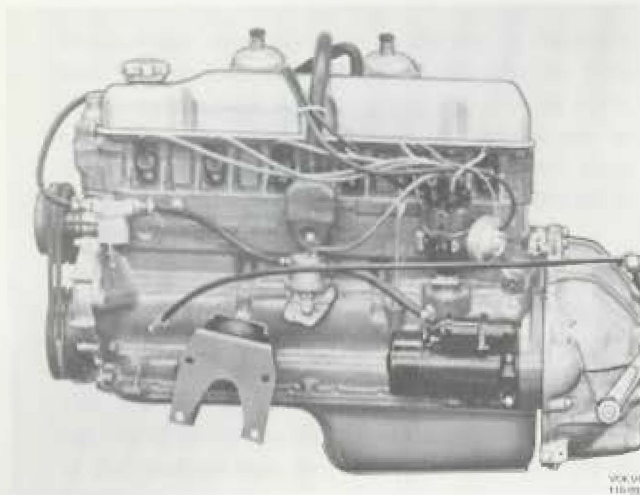

Fig. 20-5. Engine viewed from left

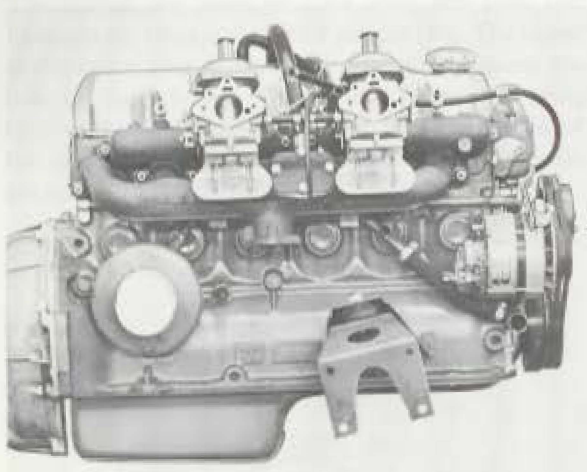

Fig. 20-6. Engine viewed from right

GENERAL

The engine has type designation B30A-498211 and is a six-cylinder, fluid-cooled overhead valve engine. It is provided with twin horizontal carburetors. The cylinder head has separate intake and exhaust ports. Engine performance can be seen from Fig. 20-7.

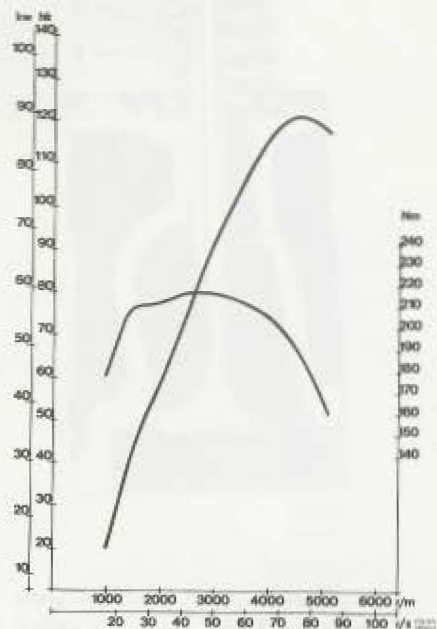

Fig. 20-7. Output and torque curves (DIN)

GROUP 21 ENGINE ASSEMBLY

Description

The cylinder head is bolted to the top of the block with head bolts. All combustion chambers are fully machined and have separate intake and exhaust ports, one for each valve. The cooling jackets are so designed that even the areas next to the spark plugs are cooled. The coolant otherwise is distributed to the warmest parts by piping.

The cylinder block is made of special cast iron and is cast in one piece. The cylinder liners, which are surrounded by cooling jackets, are machined directly in the block. The oilways in the block are arranged so that the oil cooler is directly connected to the right-hand side of the block and the oil filter, which is of the full-flow type, is directly connected to the oil cooler.

The pistons are made of light alloy and have two compression rings and one oil scraper ring. The upper compression ring is chromed, and this reduces the wear on the cylinders. The gudgeon pin has a floating fit in piston and connecting rod. The movement of the pin axially is limited by circlips in the gudgeon pin hole.

The engine has so-called "positive crankcase ventilation", that is, it is vented in an enclosed system. This is in order to prevent crankcase gases being released into the atmosphere and to prevent gas forming in the engine compartment. Fresh air is supplied via the air filters on the carburetors, and from there through a hose (2, Fig. 21-1) to the rocker arm casing. Fresh air is sucked through a metal filter (flame arrester, 4), is distributed by a plate (5) and mixed with the crankcase gases. The crankcase gases are sucked through an oil trap (6), through a hose (3) and a calibrated nipple (1) to the intake manifold. With this arrangement the exhaust gases take part in the combustion process. Residues are blown out through the exhaust pipe together with the other combustion residues.

The valves, which are fitted suspended in the cylinder head, are made of special steel and are carried in replaceable guides. The valve stems are chromed. The valve collet is provided with three lands and the valve with corresponding grooves, which hold the valve but also make suitable rotation possible, see Fig. 21-2. The valves are provided with valve guide rubber seals. Viewed in order from the front, the valves are placed: intake, exhaust, intake, exhaust, and so on.

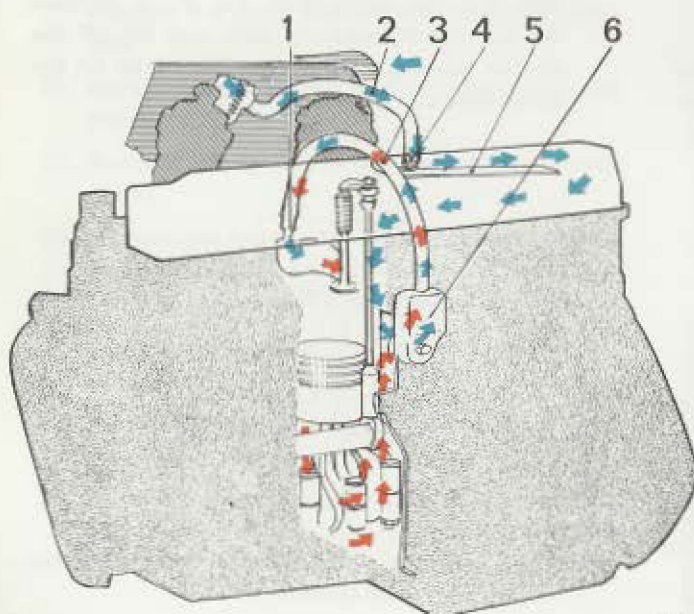

- | | |
|------------------------------|-------------------|
| 1. Nipple | 4. Flame arrester |
| 2. Hose for fresh air supply | 5. Plate |
| 3. Hose for crankcase gases | 6. Oil trap |

Fig. 21-1. Positive crankcase ventilation

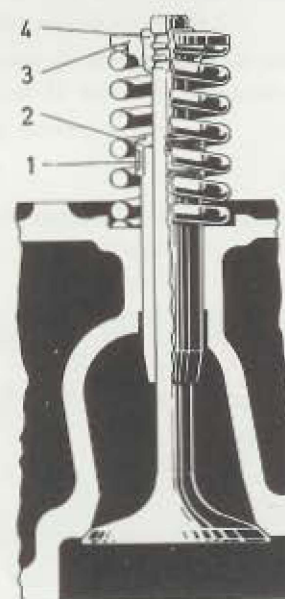

- | | |
|----------------|-----------------|
| 1. Metal ring | 3. Washer |
| 2. Rubber seal | 4. Valve collet |

Fig. 21-2. Valve collet and valve guide seal

The camshaft is made of special-alloy cast iron and has case-hardened cams. It is driven from the crankshaft through a gear train which has a ratio of 1:2. Camshaft axial location is maintained by means of a bronze axial washer located at the front end of the camshaft. Axial play is determined by a spacer ring behind the camshaft gear. The camshaft is carried in four bearings.

The valve tappets are actuated directly by the camshaft. They are located in holes in the block above the camshaft and transfer movement to the valves by means of push rods and rocker arms. There are no inspection covers for the valve tappets since these are accessible after the cylinder head has been removed.

The crankshaft is made of steel and has ground, case-hardened bearing journals. It is carried in seven main bearings, the rear flange bearing of which also functions as a pilot bearing axially. There are drilled oilways in the crankshaft for the lubricating oil.

The bearing shells, which are replaceable, consist of a steel backing with lining of indium, lead-bronze bearing metal.

The connecting rods are made of drop-forged steel and are provided with a precision-machined bushing which acts as a bearing for the gudgeon pin. The big-end bearing shells are precision-manufactured and are replaceable.

The front end of the camshaft is in the shape of a polygon. On this sits the hub (polygon hub) for the flywheel damper.

The flywheel damper is of the rubber type. The hub is jointed to the crankshaft by means of a polygon joint. The flywheel mass is journalled on the hub through a rubber suspension. The graduation for the ignition setting is marked on the flywheel damper.

Service Procedures

(Concerns the engine in the vehicle, unless otherwise indicated)

ENGINE

Removing the engine

There are two ways of removing the engine. Either remove it downwards (Method 1) or upwards (Method 2).

Special tools:

Method 1	6128	Spanner for speedometer wire
	9916	Fixture
	9809	Workshop lift
Method 2	6129	Lifting lug

1. Open the battery box and disconnect the battery earth cable.
2. **Method 1:** Remove the retaining bolts and lift off the floor cover in the platform.
Method 2: Remove the platform retaining bolts and lift off the platform.
3. Drain the coolant by disconnecting the lower radiator hose from the engine and remove the drain plug in the oil cooler.
4. Drain the engine oil.
5. Remove the inspection cover on the front engine casing.

6. Remove the upper part of the air cleaner and lift out the insert. Remove the hot-start valve control from the rear carburettor, Fig. 21-3. Remove the air cleaner retaining bolts and lift off the cleaner housing. Cover over the intake on the carburettors.

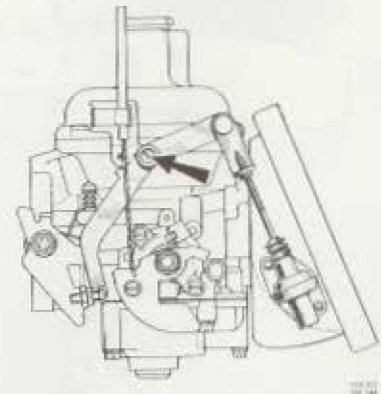

Fig. 21-3. Remove from the carburettor the hot start valve control

7. Remove the choke wire from the rear carburettor and the rear vacuum hose from the intake manifold.
8. Remove the coolant hose from the coolant pipe under the manifold.

9. Remove the hose for the oil pressure gauge from the nipple in the cylinder block.
10. Disconnect the electric cables from the temperature sender and the gearbox and distribution box.
11. Remove the vacuum hose from the vacuum box on the distribution box.
12. Remove the speedometer wire from the gearbox, using spanner 6128.
13. Remove the ignition cable and electric cable to the ignition distributor from the ignition coil.
14. Remove the ventilation hoses (3) from the clutch casing, gearbox and distribution box.
15. Remove the shift controls from the gearbox.
16. Remove the clutch wire from the throw-out clutch lever and from the clutch casing.
17. Disconnect the electric cables from the starter motor.
18. Remove the fuel hose from the fuel pump.
19. Pull loose the lock clip for the parking brake wire sleeve, front end. Remove the lock nut and the adjuster sleeve. Remove the rubber bellows and the wire through the body attachment.
20. Remove lock clip and disconnect link rods of carburettors from throttle control shaft. Remove shaft's lock clip and then the shaft from the manifold bracket. Hang up the shaft.
21. Remove the upper radiator hose from the engine. Remove the front vacuum hose from the manifold.
22. Mark and remove the electric cables from the alternator.
23. Remove the fan shaft from the coolant pump pulley.
24. Remove the front exhaust pipe section from the manifold flange, the silencer flange and the attachment on the clutch casing. Take down the pipe.
25. Remove the earth connection from the clutch casing.
26. Remove the front propeller shaft section from the distribution box.
27. Remove the rear propeller shaft section. Fit two nuts which hold the drum for the propeller shaft brake in position.

28. Removing the engine downwards

Method 1

- a. Remove the reinforcing bracket between the engine and clutch casing. Take care not to deform the sealing plate.
- b. Place engine fixture 9916 on workshop lift 9809. Run the jack in under the engine, jack up and screw tight the fixture, see Fig. 21-4.

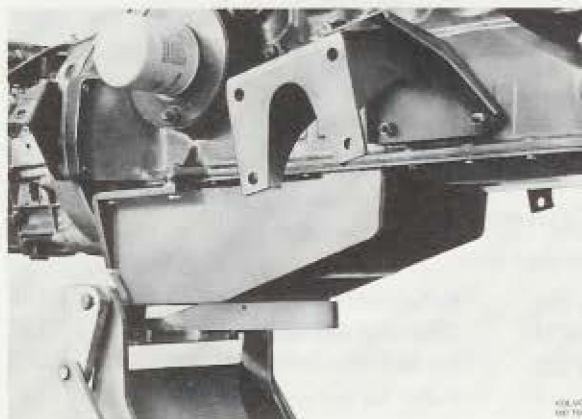

Fig. 21-4. Fixing the engine in fixture 9916

- c. Remove the engine mounts (4) from the frame members.
- d. Lower the engine.
- e. Jack up and place stands under the vehicle. Pull the engine forwards.

29. Removing the engine upwards

Method 2

- a. Fit lifting lug 6129 on the rear cylinder head bolts, see Fig. 21-5.



Fig. 21-5. Attaching the lifting lug 6129

- b. Run the engine jack in under the engine. Swing in hoist over the engine and secure its lifting hook to the lifting lug 6129.
- c. Remove the lower retaining bolts (in the frame members) for the rear engine mounts.
- d. Raise the engine jack so as to off-load the front engine mounts. Remove the retaining bolts in the frame members (4 per side) for the engine mounts.
- e. Lower the engine jack so as to off-load the rear engine mounts. Remove the upper retaining bolts.
- f. Lift out the engine. Take care that the engine does not knock against brake pipes or the fuel pipe.

Disassembling

Special tools:

2250	Puller for camshaft gear
2424	Grip tool (for valve tappets)
2520	Stand
2814	Puller for polygon hub
2820	Fixture
2822	Puller for crankshaft gear

After the engine has been lifted out of the vehicle, it should be disassembled more or less according to below. (For the instructions concerning the individual parts, see under their respective headings.)

1. Remove the oil trap, fuel pump and left engine mount. Mount the engine on stand 2520 with fixture 2820, Fig. 21-6.

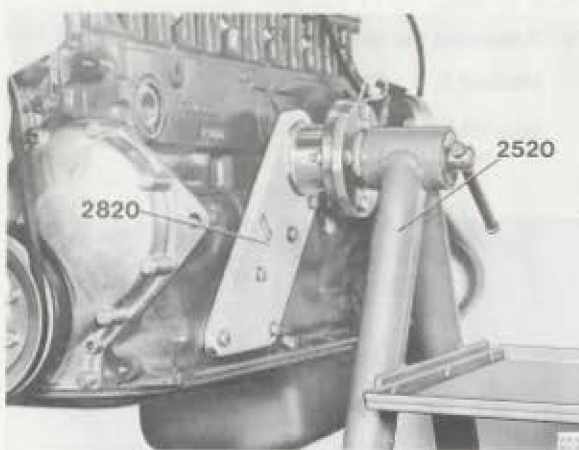

Fig. 21-6. Engine on stand

2. Remove the starter motor and gearbox and thereafter the clutch and flywheel.
3. Remove fixture 9916 (reinforcing bracket) from the engine.

4. Remove the alternator, coolant pump, distributor, rocker arm casing, rocker arm mechanism, push rods, oil filter and oil cooler. Remove the manifold and carburettors. Remove the cylinder head. Remove the valve tappets with tool 2424, Fig. 21-7.

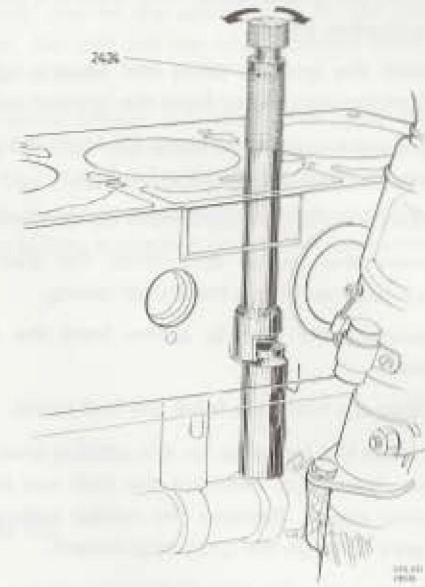

Fig. 21-7. Lifting out valve tappets

5. Remove the crankshaft pulley and vibration damper.
6. Remove the centre bolt and pull off the polygon hub with puller 2814, Fig. 21-8. (First test to see whether the polygon hub can be pulled off by hand.)



Fig. 21-8. Removing the polygon hub

7. Remove the timing gear casing.
8. Remove the camshaft nut and pull off the gear with puller 2250, Fig. 21-9.

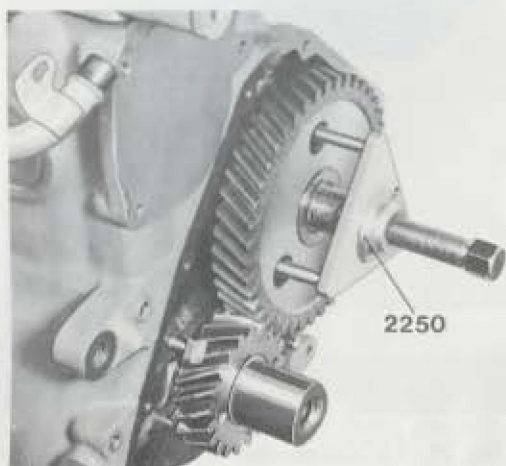

Fig. 21-9. Removing the camshaft gear

9. Pull off the crankshaft gear with puller 2822, Fig. 21-10.

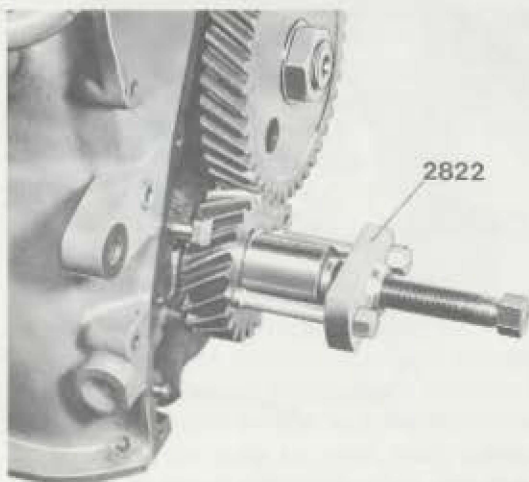

Fig. 21-10. Removing the crankshaft gear

10. Remove the camshaft and oil nozzle.
11. Remove the carbon border on the cylinder liners.
12. Turn over the engine so that the underside is up.
13. Remove the oil sump, rear sealing flange, oil pump and pistons with connecting rods. Put back the caps correctly on their respective rods.
14. Remove the crankshaft. Place the caps properly in their respective positions.

Cleaning

After disassembling the parts, wash them thoroughly. Parts made of steel or cast iron can be washed in a degreasing tank with a caustic soda solution. Light-alloy parts can, however, be damaged by caustic soda so that they should preferably be cleaned in white spirit. Rinse the parts with warm water and blow them dry with compressed air after washing. Clean the oilways with particular thoroughness. All sealing plugs at the oilway openings in the cylinder block must be removed during the cleaning process.

Assembling

Special tools:

2408	Press tool for fitting camshaft gear
2424	Grip tools for valve tappets
2435	Dowels for cylinder head
2815	Press tool for fitting crankshaft gear and polygon hub
2816	Drift for front crankshaft seal
2817	Drift for rear crankshaft seal
2823	Dowel for fitting standard piston

When assembling the engine, follow the instructions for the components concerned. Check the marking of the bearings according to Fig. 21-11. The main bearings are marked 1-7, and the big-end bearings 1-6, counting from the front.

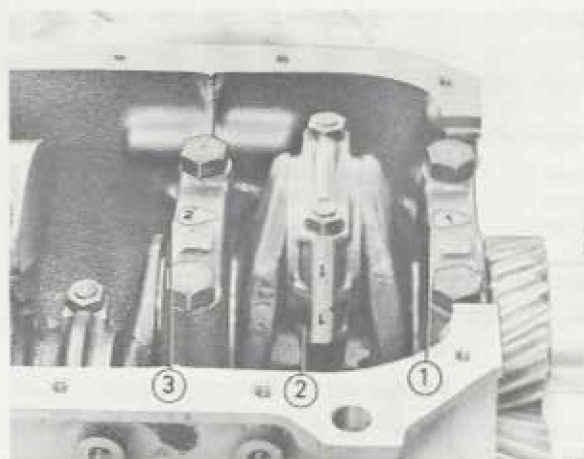

1. Main bearing No. 1
2. Big-end bearing No. 1
3. Main bearing No. 2

Fig. 21-11. Marking of main bearings and big-end bearings

Check that all parts are clean and lubricate sliding surfaces with oil before assembling. Always use new gaskets, split pins and lock washers. No adhesive should be used on the gaskets. Sealing at the ends of

both the oil pump delivery pipe and the water pumps is provided with rubber rings. These rings, which seal radially, are made of special rubber with very close tolerances. Only genuine Volvo parts should be used. Fitting is made easier by coating the rings with soapy water. Slip the rings on the pipes and then press them into their respective positions before finally tightening the attaching screws. The oil pump flange should lie flush against cylinder block before tightening.

Crankshaft seals at the front and rear ends respectively are installed according to the instructions given on pages 21:16 and 21:20. When reconditioning, replace the connecting rod, bolts and nuts with new ones. Use dowels 2435 for fitting the cylinder head. The bolts must be tightened in a certain sequence, see Fig. 21-12, in order to avoid unnecessary stresses. The bolts should be tightened in two stages and final-tightened after the engine has been run warm and allowed to cool.

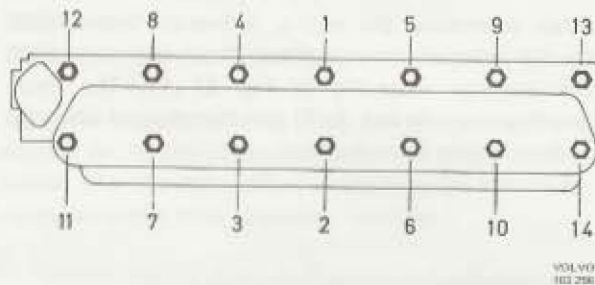

- Should be tightened in three stages
- Stage 1: 40 Nm (4 kpm = 29 lbftf)
 - Stage 2: 80 Nm (8 kpm = 58 lbftf)
 - Stage 3: engine run warm and allowed to cool
90 Nm (9 kpm = 65 lbftf)

Fig. 21-12. Tightening sequence for cylinder head bolts

Check that the oil hole (Fig. 21-13) for lubricating the rocker arms is not blocked.

The pilot bearing (5, Fig. 21-14) should be lubricated before being fitted with heat-resistant ball bearing grease. The bearing and protecting washer are held in position by a circlip (6).

Fit the flywheel and clutch and then the gearbox and starter motor.

The most important bolts and nuts should be tightened with a torque wrench, see "Tightening Torques" in the data section, page 20:6.

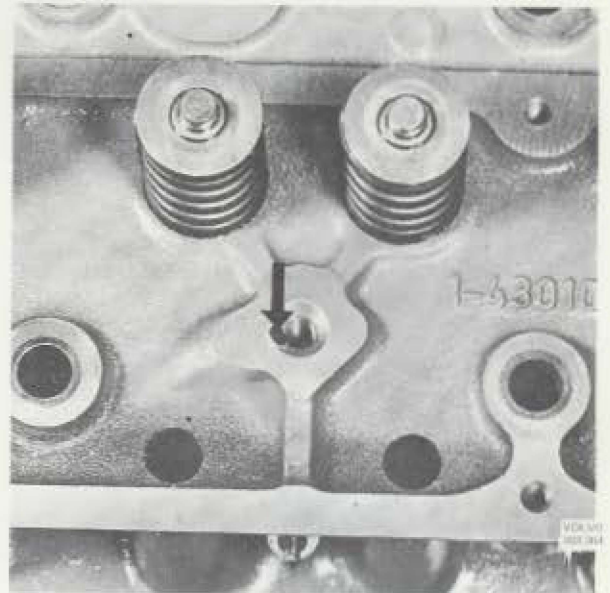
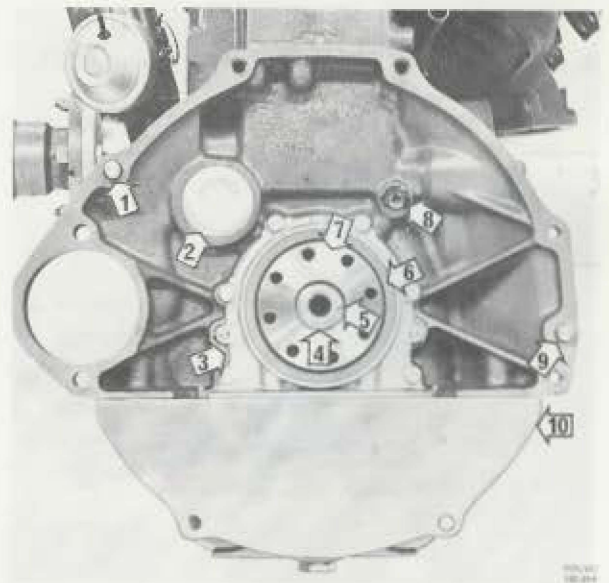

Fig. 21-13. Oil channel in cylinder head



- 1. Dowel
- 2. Sealing washer
- 3. Sealing flange
- 4. Circlip
- 5. Pilot bearing
- 6. Sealing ring
- 7. Crankshaft
- 8. Plug
- 9. Dowel
- 10. Sealing plate

Fig. 21-14. Rear end of engine

Installing the engine

The engine can be installed in two ways. Either from underneath (Method 1) or it can be lifted into position from the top (Method 2).

Special tools:

	6128	Spanner for speedometer wire
Method 1	9916	Fixture
	9809	Workshop lift
Method 2	6129	Lifting lug

1. Installing the engine from underneath

Method 1

- Remove the engine from fixture 2820 and place it in engine fixture 9916, Fig. 21-4. Fit the oil trap, fuel pump and left engine mount.
- Run the engine into position under the vehicle. Lower the vehicle and make sure that the engine does not catch on anything.
- Raise the engine and screw tight the engine mounts (4).
- Remove fixture 9916 from the engine.
- Fit the reinforcing bracket between the engine and clutch casing. Do not forget the spacer washers on the front retaining bolts between the bracket and engine. First screw the bolts tight by hand, then tighten the bolts against the clutch casing and after that the bolts against the engine.

2. Installing the engine from above

Method 2

- Fit the reinforcing bracket between the engine and clutch casing. Do not forget the spacer washers on the front retaining bolts between the bracket and engine. First screw tight the bolts by hand, then tighten the bolts against the clutch casing, and after that the bolts against the engine.
- Fit lifting lug 6129 on the rear cylinder head bolts.
- Secure the engine lift to the lifting lug and remove the engine from fixture 2820.
- Fit the oil trap, fuel pump and left engine mount.
- Lift the engine into position taking care to make sure that the brake pipes and fuel pipe do not get jammed.
- Fit the upper front retaining bolts to the front engine mounts.

- Lower the engine and fit the retaining bolts for the rear engine mounts.
 - Fit the remaining retaining bolts in the front engine mounts.
 - Hook loose and remove the engine lift. Remove the lifting lug.
- Fit the braided cable to the clutch casing.
 - Fit the propeller shaft sections.
 - Fit the front exhaust pipe section, use new flange gaskets. Clamp the pipe tight to the attachment on the clutch casing.
 - Fit the lower radiator hose and the coolant hose to the pipe under the manifold. Fit the drain plug in the oil cooler.
 - Fit the oil pressure gauge hose to the nipple in the cylinder block.
 - Fit the fan shaft to the coolant pump pulley.
 - Connect the electric cables to the alternator.
 - Fit the throttle control shaft to the manifold bracket. Fit the lock clip. Fit the link rods to the shaft. Fit the shaft lock clip.
 - Fit the upper radiator hose and connect the front vacuum hose to the manifold.
 - Insert the wire for the parking brake through the body attachment. Fit the rubber bellows and the sleeve lock clips. Fit the adjuster nut and adjust so that the wire is stretched and the parking brake lever has the least possible looseness. Concerning adjustment of the propeller shaft brake, see Part 5. Fit the lock nut.
 - Fit the fuel hose to the fuel pump.
 - Fit the electric cables to the starter motor.
 - Fit the clutch wire and adjust the clearance, which should be 4-5 mm (0.016-0.020"), Fig. 21-15.
 - Fit the gear controls for the gearbox.
 - Fit the ventilation hoses (3) to the clutch casing, gearbox and distribution gear.
 - Fit the ignition cable and electric cable to the ignition coil and the electric cable to the temperature sender.
 - Fit the speedometer wire to the gearbox, using spanner 6128 tightening.
 - Fit the electric cables to the gearbox and the distribution gear.
 - Fit the vacuum hose to the distribution gear vacuum box.
 - Connect the rear vacuum hose to the manifold.

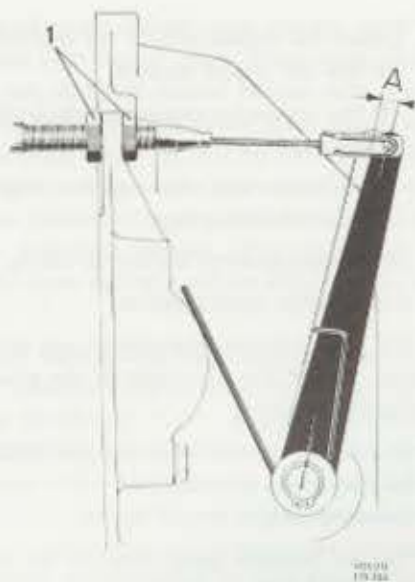

A = 4–5 mm (0.16–0.20")

1. Adjuster nut

Fig. 21–15. Throw-out lever travel

23. Fit the air cleaner housing. Fit the hot start valve control to the rear carburettor. At idle position, the valve control should be against the throttle control lever. Fit the air cleaner insert and put on the upper part of the air cleaner.
 24. Fit the choke wire to the rear carburettor.
 25. Fill with coolant through the opening in the radiator, the heater control should be at max. heat. Fill the radiator fully and put on the cap. Also fill the expansion tank to the MAX mark.
 26. Fill with engine oil.
 27. Connect the battery earth cable and close the battery box.
 28. Start the engine and carry out a function check.
 29. Fit the inspection cover on the front engine casing.
 30. **Method 1:** Fit the roof cover in the platform.
Method 2: Fit the platform.
3. Drain the coolant by opening the drain cock on the lower radiator pipe.
 4. Remove the inspection cover on the front engine casing and the floor cover in the platform.
 5. Remove the upper radiator hose from the engine.
 6. Remove the fuel hose from the distribution pipe at the carburettors and from the clamp at the thermostat housing. Bend the hose to the one side.
- Remove the vacuum hose from the front carburettor and the hoses for the crankcase ventilation from the manifold and air cleaner.
7. Remove the alternator tensioning bar from the cylinder head.
 8. Remove the clasps and take off the upper part of the air cleaner housing.
 9. Disconnect the electric cable from the temperature sender and the choke wire from the rear carburettor.
 10. Remove the front exhaust pipe section from the silencers and the attachment on the clutch casing.
 11. Remove the flange nuts "manifold – cylinder head" and move the manifold to the one side.
 12. Disconnect the spark plug cables from the spark plugs.
 13. Remove the rocker arm cover and the rocker arm mechanism and push rods.
 14. Remove the cylinder head bolts and lift off the head.
 15. Remove the cylinder head gasket, the manifold gasket and the sealing rings for the coolant pump. Clean the contact surfaces.

CYLINDER HEAD

Special tools:

2435	Dowels
2898	Spanner for final-tightening cylinder head bolts

Removing

1. Open the battery lid and disconnect the battery earth cable.
2. Remove the platform.

Checking surface unevenness (Grinding even)

Deviations in the cylinder head surface unevenness may amount to max. 0.05 mm (0.002") per 100 mm (4") length. Check the surface evenness with a surface gauge. If the cover has to be ground smooth, grind off as little as possible.

Fitting the cylinder head

1. Check to make sure that the sealing surfaces on the cylinder block and head are clean, even and undamaged, also that the oil channel in the cylinder head (Fig. 21–16) for the rocker arm mechanism is clean.

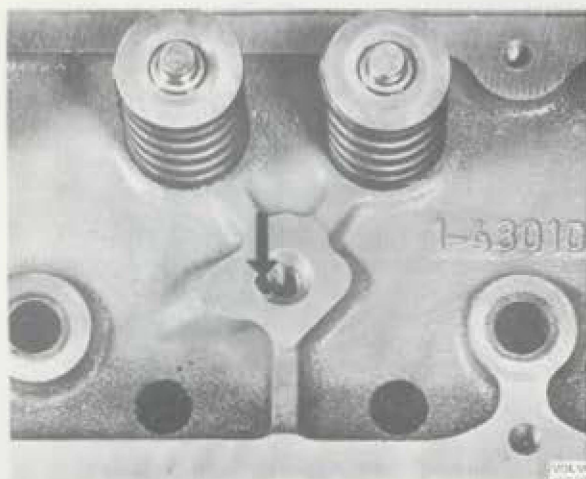

Fig. 21-16. Oil channel in cylinder head

2. Place the cylinder head gasket with TOP facing upwards (wide edge facing upwards) on the cylinder block.
Fit the coolant pump sealing rings.
Screw dowels 2435 into the cylinder block, one at the rear left and one at the front right screw hole.
3. Fit the cylinder head and the retaining bolts.
Tighten in the sequence shown in Fig. 21-17 and in two stages: 1-40 Nm (4 kpm = 29 lbftf), stage 2-80 Nm (8 kpm = 57 lbftf).

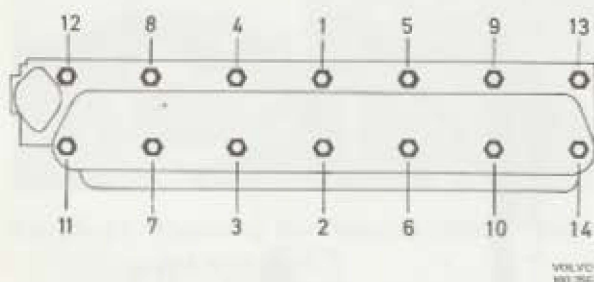

Fig. 21-17. Tightening sequence for cylinder head bolts

4. Fit the push rods in position and mount the rocker arm mechanism.
5. Adjust the valve clearance to 0.45-0.50 mm (0.018-0.020"). NOTE! These values are not the final ones.
6. Fit the rocker arm cover.
7. Connect the spark plug cables to the spark plugs.

8. Fit the new manifold gasket to the cylinder head and lift the manifold into position.
Fit the washers and flange nuts.
9. Fit the front exhaust pipe section to the silencer and to the attachment on the clutch casing.
10. Fit the electric cable to the temperature sender and choke wire to the rear carburettor.
11. Fit the air cleaner housing upper part.
12. Fit the alternator tensioning bar and adjust the belt tension.
13. Fit the fuel hose to the clamp at the thermostat housing and the branch pipe at the carburettors.
Fit the vacuum hose to the front carburettor and the hoses for the crankcase ventilation to the manifold and air cleaner.
14. Fit the radiator hose.
15. Close the drain cock on the lower radiator pipe.
16. Fill with coolant through the radiator opening, the heater control should be at MAX heat. Fill the radiator fully and fit the cap. Also fill the expansion tank to the MAX mark.
17. Connect the battery earth cable to the battery and close the battery box.
18. Start the engine and carry out a function check. Run the engine for about 10 minutes (preferably under load).
19. Remove the rocker arm cover.
20. Check-tighten the cylinder head bolts, after the engine has cooled, in correct sequence to 90 Nm (9 kpm = 65 lbftf). Use spanner 2898 for this purpose, see Fig. 21-18.

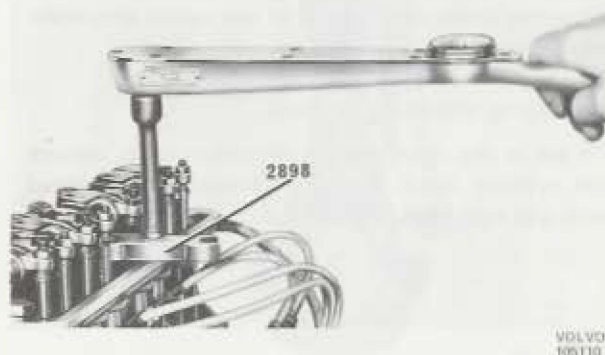

Fig. 21-18. Check-tightening cylinder head bolts

21. Check and if necessary adjust the valve clearance to 0.40-0.45 mm (0.016-0.018").
22. Fit the rocker arm cover.
23. Fit the inspection cover on the front engine casing.
24. Fit the platform.

VALVE MECHANISM

Special tools:

1867	Drift
2425	Grip tool
2818	Drift
2819	Drift

Adjusting the valve clearance

It is an advantage to adjust the valve clearance with the engine switched off, either cold or hot. The clearance is the same for both inlet and exhaust valves (0.40–0.45 mm = 0.016–0.018"). When adjusting, use two feeler gauges, one "Go" 0.40 mm (0.016") thick and the other "No-Go" 0.45 mm (0.018") thick.

The clearance is adjusted so that the thinnest gauge can be inserted easily while the thicker one must not enter.

Remove the rocker arm cover. Turn over the crankshaft until No. 1 is at firing position. The rocker arms for No. 6 "rock". The marking on the pulley is at 0. Adjust the valve clearance for No. 1.

Turn over the crankshaft until No. 2 rocker arms "rock" - adjust the clearance for No. 5.

When No. 4 rocker arms "rock" - adjust No. 3 clearance.

When No. 1 rocker arms "rock" - adjust No. 6 clearance.

When No. 5 rocker arms "rock" - adjust No. 2 clearance.

When No. 3 rocker arms "rock" - adjust No. 4 clearance.

Clean the inside and outside of the rocker arm cover and fit it.

Replacing the valve tappets

To get at the valve tappets to replace them, remove the cylinder head. The valve tappets are removed with grip tool 2424, Fig. 21-19.



Fig. 21-19. Removing and installing valve tappets

Replacing the valve guides

1. Press out the old guides with drift 2818.
2. Press in the new guides with drift 2819, which gives the correct pressing-in depth, Fig. 21-20.
3. Check that the guides are free from burr and that the valves move easily in them.

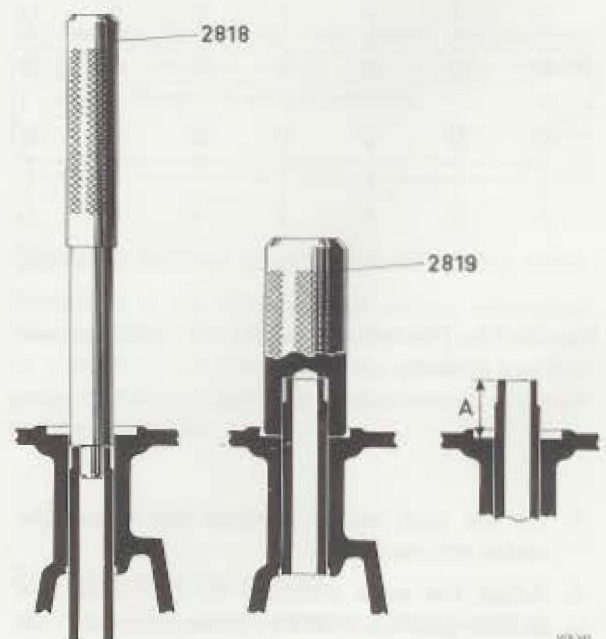

A = 17.5 mm (0.69")

Fig. 21-20. Replacing valve guides

Grinding the valves and valve seats

1. Remove the valve springs by first compressing them with valve spring pliers and then remove the valve collets after which release the pliers. Place the valves in order on a rack.

2. With rotating brushes clean the valves, combustion chambers and channels of carbon and combustion deposits. Check the surface condition of the cylinder head.

The surface unevenness of the cylinder head may amount to max. 0.05 mm (0.0020") per 100 mm (4") length. The surface condition is checked with a level disc. If the cylinder head surface has to be machined level, remove as little material as possible.

3. Measure the clearance between the stem and guide, Fig. 21-21. With a new valve the clearance should not exceed 0.15 mm (0.0060") Also check to make sure the valves are not excessively worn. Wear on the valve stems may amount to max. 0.02 mm (0.0008").

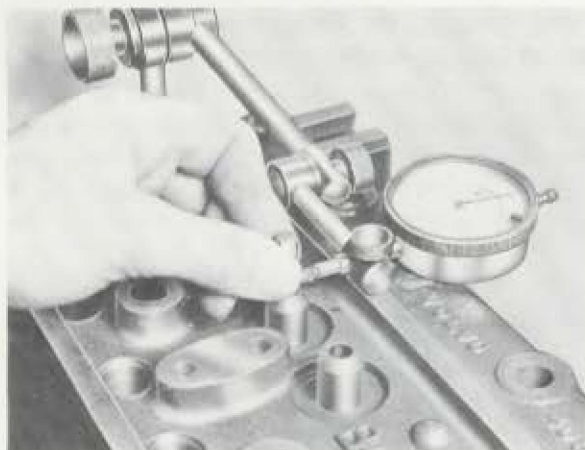
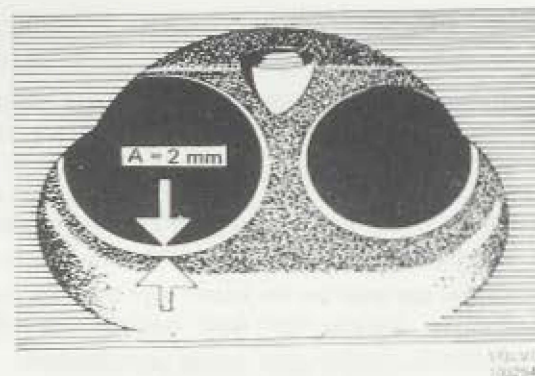

Fig. 21-21. Measuring the clearance between guide and valve stem

4. Grind the valves in a valve grinding machine after cleaning them. The valve seat angle should be 44.5° . Replace valves if excessively worn.
5. Grind the valve seats in the cylinder head. Use an electrically driven grinder or a hand milling cutter. A pilot spindle must be carefully fitted before work is started and any worn guides must be replaced by new ones. The seat should be ground until a good sealing surface is obtained. The angle is 45.25° and the width of the sealing surfaces approx. 2 mm (0.08"), see "A", Fig. 21-22.



A = 2 mm (0.08")

Fig. 21-22. Valve seat width

If the sealing surface is too wide after grinding, it can be reduced by using a 70° grinding stone from the inside and a 20° grinding stone from the outside.

6. Check the sealing with marking colour and if necessary grind the valves with fine grinding paste.
7. Check the valve springs with a spring tester, Fig. 21-23. If the springs are not according to the values given in the data for springs, see page 20:3, they should be scrapped.



Fig. 21-23. Testing a valve spring

8. Oil the valve stems and place the valves in their guides. Fit the valve guide seals, valve springs, washers and locks.

Rocker arm mechanism

Disassembling and checking

1. Remove the lock rings on both ends of the rocker arm shaft.
2. Dismantle the rocker arm mechanism.
3. Check that the rocker arm shaft is not damaged and that the oil channels are clean.
4. Check for wear on the rocker arm bushings and contact surfaces. If wear exceeds 0.1 mm (0.004"), replace the rocker arm bushing. If necessary grind the thrust area against the valve in a special grinding machine.
5. If the bushings are to be replaced, use drift 1867 for pressing them out and in, Fig. 21-24. Then ream the bushing with a suitable reamer to an accurate fit on the shaft. The hole in the bushing should be opposite the hole in the rocker arm.



Fig. 21-24. Replacing a rocker arm bushing

Assembling

1. Before assembling the rocker arm mechanism clean all parts thoroughly and check them.
2. Assemble the bearing brackets, springs, rocker arms and shaft according to Fig. 21-25. Lock the parts with new lock rings. Note that the rocker arms are of two types, left and right.

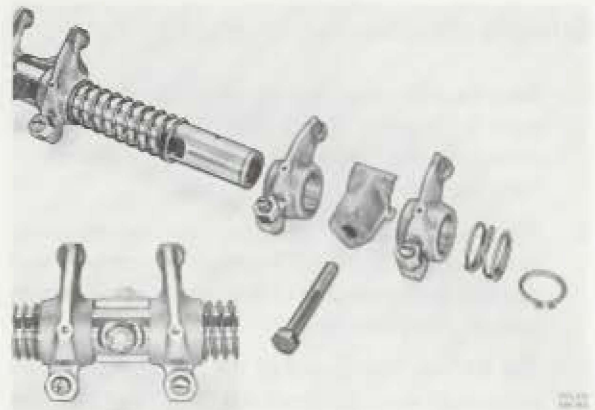

Fig. 21-25. Rocker arm mechanism

CYLINDER BLOCK

Measuring the cylinder bores

The cylinder bores are measured with a special dial indicator, Fig. 21-26.

The measuring should be carried out just below the top edge of the bore only in the transverse direction of the engine. A letter is stamped on each cylinder bore indicating the classification of the bore and piston (only on standard models).

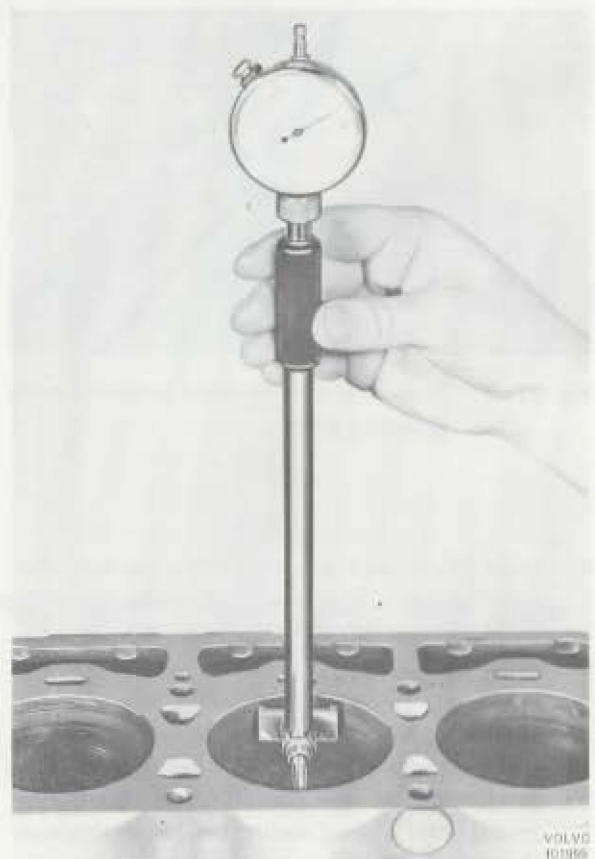

Fig. 21-26. Measuring a cylinder bore

PISTONS AND CONNECTING RODS

Special tools:

5017	Drift
2873	Installation ring

Removing

1. Remove the cylinder head. See under "Removing the cylinder head", page 21-8.
2. Drain the engine oil.
3. Remove the reinforcing bracket between the cylinder block and the clutch casing. Remove the oil sump.
4. Remove the big-end bearing caps and move up the pistons and connecting rods through the cylinder bores. Put back the caps properly on their respective connecting rods. Hang up the pistons and connecting rods on a special rack or place them on a clean, soft base.

Measuring the pistons and piston fit

Measure the piston diameter with a micrometer, at right angles to the gudgeon pin hole and 7 mm (0.28") from the lower edge.

Test the fit of the pistons in the respective bores, without piston rings. Measure the clearance, which should be 0.01–0.03 mm (0.0004–0.0012"), at right angles to the gudgeon pin hole with a feeler gauge, 1/2" wide and 0.02 mm (0.0008") thick, attached to a spring balance. The pulling force should be 10 N (1 kp = 2.2 lbft.), see Fig. 21-27. With this pulling force



Fig. 21-27. Measuring the piston clearance

a piston clearance is obtained equal to the thickness of the feeler gauge blade used. The blade thickness which is equally as thick as the indicated outer values for the piston clearance can, therefore, also be used. Try this out at several different depths. Cylinder bores of standard bore size have a letter marking which indicates the measurement and the respective piston should be marked with the same letter.

Replacing the piston rings

1. Remove the piston rings with piston ring pliers.
2. Clean the pistons, taking particular care with the piston ring grooves.
3. Fit the piston rings, one after the other, down into the cylinder bore. Use an inverted piston to ensure that the rings are fitted properly.
4. Measure the ring gap with a feeler gauge. The gap should be 0.40–0.55 mm (0.016–0.022"). If necessary, the gap can be increased with the help of a special file.

NOTE! When checking the fit in a worn cylinder bore, the rings must be checked at the bottom dead centre position where the diameter of the bore is smallest.

5. Check the piston rings in the respective ring grooves by rolling them in the groove. Also measure the clearance at several points, Fig. 21-28. This clearance should be 0.040–0.072 mm (0.0016–0.0028") for both compression rings and the oil scraper ring.



Fig. 21-28. Measuring the piston ring clearance in groove

6. Fit the piston rings with piston ring pliers. The chromed compression ring should be at the top. Turn the rings so that their gaps are apart from each other.

Replacing the gudgeon pins and gudgeon pin bushings

1. Remove the piston rings with piston ring pliers.
2. Remove the circlips and pull out the gudgeon pin.
3. Check the gudgeon pin hole in the piston. If the gudgeon pin hole in the piston is worn so that the oversize (+0.05 mm = 0.002") is required, first ream up the hole to the correct measurement. Use a reamer fitted with pilot guide and take only small cuts at a time.
The fit is correct when the gudgeon pin can be pushed through the hole by hand with light resistance.
4. If the gudgeon pin bushing is too worn, press it out with drift 5017, Fig. 21-29. A new bushing is pressed in with the same tool, the other end of which is now used. Make sure that the lubricating holes are opposite the holes in the connecting rods. Then ream the bushing to the correct fit.

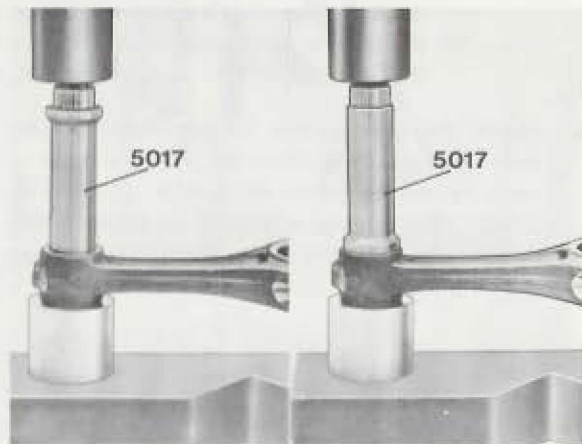

Fig. 21-29. Changing the gudgeon pin bushing



Fig. 21-30. Gudgeon pin fit

The gudgeon pin should glide through the hole under light thumb pressure but without any noticeable looseness, Fig. 21-30.

5. If necessary check the connecting rods for straightness and warp, Fig. 21-31.

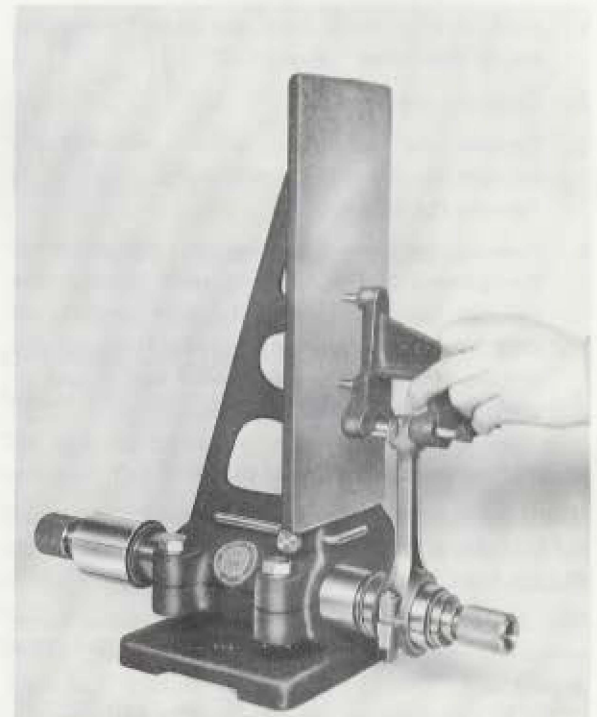

Fig. 21-31. Checking the connecting rod

6. If necessary check the connecting rods for any S-distortion. Let the transverse areas at the connecting rod big end rest against the pulled out support on the measuring apparatus. Measure the distance between the indicating plate and the transverse area at the little end of the connecting rod, and then turn the connecting rod and carry out the same measurement for the other side. The results should agree with a permitted deviation of 0.5 mm (0.020").
7. If the connecting rod is bent or twisted it can be straightened with the straightening tools which belong to the checking and straightening apparatus. The straightening must be carried out with great care.
8. Assemble the piston and connecting rod, using new circlips. NOTE! The groove on the top of the piston should point forwards and the number marking on the connecting rod should face away from the camshaft side, Figs. 21-32 and 21-33.
9. Replace the connecting rod bolts and nuts with new ones.

VOLVO
103279

Fig. 21-32. Marking on piston and block



1. Main bearing No. 1
2. Big-end bearing No. 1
3. Main bearing No. 2

Fig. 21-33. Marking the main and big-end bearings

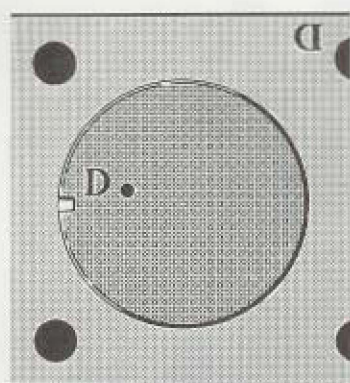
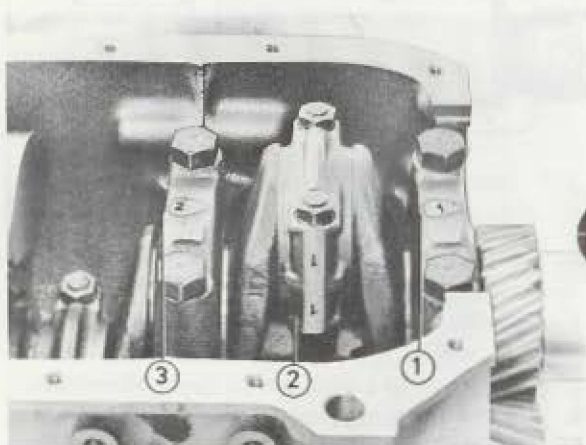
Installing

1. Check that pistons and connecting rods are properly located in relation to each other and to the cylinder block, Figs. 21-32 and 21-33.
2. Turn the piston rings so that their gaps are apart from each other. Oil pistons and bearing surfaces.
3. Fit the pistons with connecting rods in the cylinder bores. Use installation ring 2823, Fig. 21-34. Make sure that the number markings on the connecting rods are facing away from the camshaft side and that the groove in the gudgeon pin points forwards, Figs. 21-32 and 21-33.



Fig. 21-34. Installing a piston

4. Fit the connecting rod caps. Fit and tighten up the connecting rod nuts to a torque of 63-70 Nm (6.3-7.0 kpm = 45-50 lbftf).
5. Fit the sealing plate and the oil sump. The "tongue" on the oil sump gasket should face towards the starter motor flange.
6. Fit the reinforcing bracket, and tighten all bolts by hand. Do not forget the spacer washers on the front retaining bolts, between the bracket and engine. Then tighten up the bolts against the flywheel casing and thereafter the bolts against the cylinder block.
7. Install the cylinder head. See under "Installing the cylinder head", page 21:8.
8. Fill the engine with oil. Carry out a function check.

CRANKCASE VENTILATION (inspection)

Remove the nipple in the intake manifold, hoses and flame arrester (metal filter) and clean them. If necessary replace the flame arrester. At the same time check the hoses and replace them if in poor condition.

TIMING GEARS

Special tools:

2250	Puller
2408	Press tool
2424	Grip tool
2814	Puller
2815	Press tool
2816	Drift
2822	Puller

Timing gear casing

Replacing the sealing ring

1. Slacken the drive belts. Remove the bolts for the pulley and vibration damper and remove both pulley and damper.
2. Remove the centre bolt and pull off the polygon hub with puller 2814, Fig. 21-35.
(First see whether the polygon hub can be pulled off by hand.)

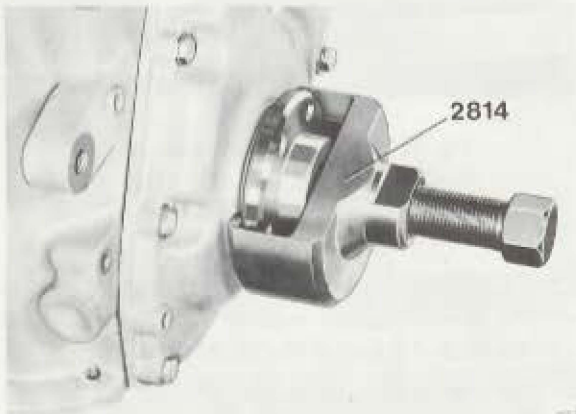

Fig. 21-35. Removing the polygon hub

3. Lever out the sealing ring. Oil the sealing lip on the new sealing ring and fit the ring with drift 2816, Fig. 21-36.

NOTE! First inspect the wear surface on the polygon hub. The sealing ring can be fitted in three positions with drift 2816. With a new polygon hub the tool centre bolt should be screwed in fully, Fig. 21-37. In this position, the sealing ring will be placed in its outer position (position 1). With a wear mark on the polygon hub place the sealing ring in position 2 (centre bolt screwed out 1 1/4 threads). With two wear marks place the sealing ring in position 3 (centre bolt screwed out fully). With three wear marks the polygon hub should be replaced with a new one.



Fig. 21-36. Installing the timing gear casing seal

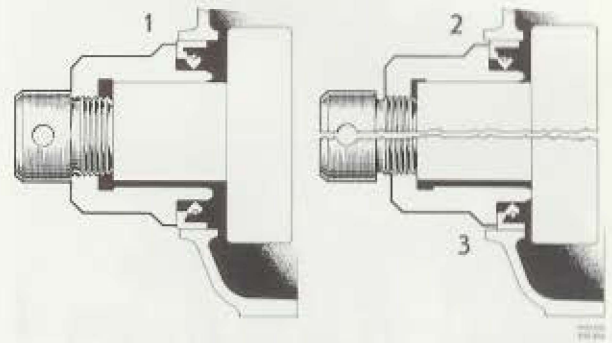

Fig. 21-37. Locations of centre bolt on tool 2816

4. Fit the polygon hub with press tool 2815, Fig. 21-38. Before fitting it, grease the slide surfaces of the hub. Note the marking, punch pops on the end of the crankshaft and polygon hub. Fit the centre bolt and tighten it to a torque of 95-105 Nm (9.5-10.5 kpm = 69-76 lbftf).

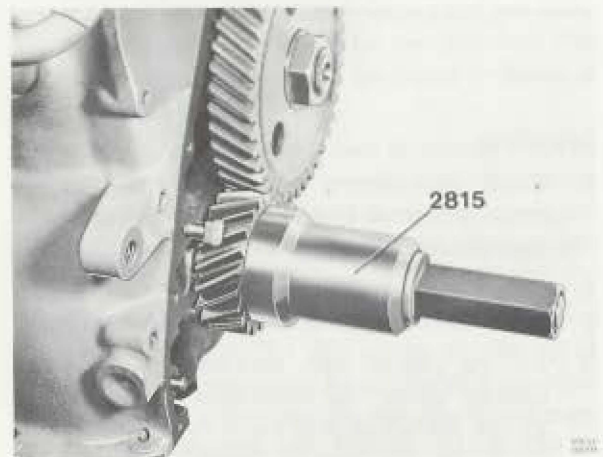

Fig. 21-38. Installing the polygon hub

5. Fit the vibration damper and pulley. The bolt holes are asymmetrically placed so that these components can only be fitted in one position.
6. Fit the drive belts and adjust the belt tension.

Removing the timing gear casing

1. Remove the fan shaft from the coolant pump pulley. Slacken the drive belts and remove the pump pulley.
2. Remove the crankshaft pulley and vibration damper.
3. Remove the centre bolt and pull off the polygon hub with puller 2814, Fig. 21-35. (But first try to see whether the polygon hub can be pulled off by hand.)
4. Remove the timing gear casing. Slacken a couple of bolts extra for the oil sump and observe due care not to damage the sump gasket.

Installing

1. Install the timing gear casing with gasket. The casing is located properly by means of dowels.
2. Fit the polygon hub with press tool 2815, Fig. 21-38. Before installing the hub, grease the hub slide surfaces. **Note the marking, punch pops on the crankshaft end and polygon hub, fit the centre bolt and tighten it to a torque of 95-105 Nm (9.5-10.5 kpm = 69-76 lbftf).**
3. Fit the vibration damper and pulley. The bolt holes are asymmetrically placed so damper and pulley can be fitted in one position.
4. Fit the coolant pump pulley and drive belts, and adjust the belt tension.
5. Install the fan shaft.

Timing gears

Replacing

1. Remove the timing gear casing. See under "Removing the timing gear casing", above.
2. Remove the camshaft nut and pull the gear off with puller 2250, Fig. 21-39.
3. Pull off the crankshaft with puller 2822, Fig. 21-40.
4. Screw out the oil nozzle, blow it clean and re-fit it according to Fig. 21-41.
The gears are lubricated by oil from the nozzle.

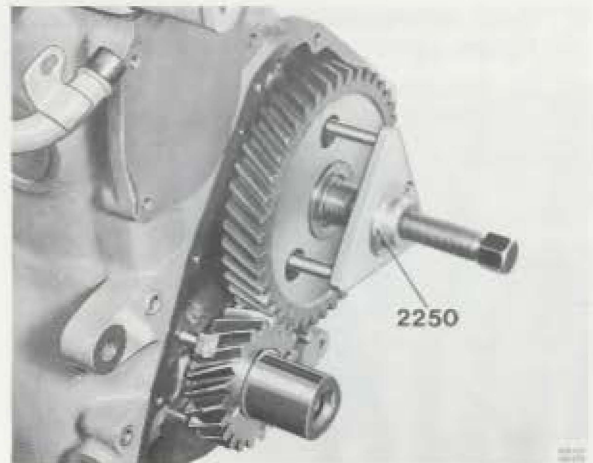

Fig. 21-39. Removing the camshaft gear

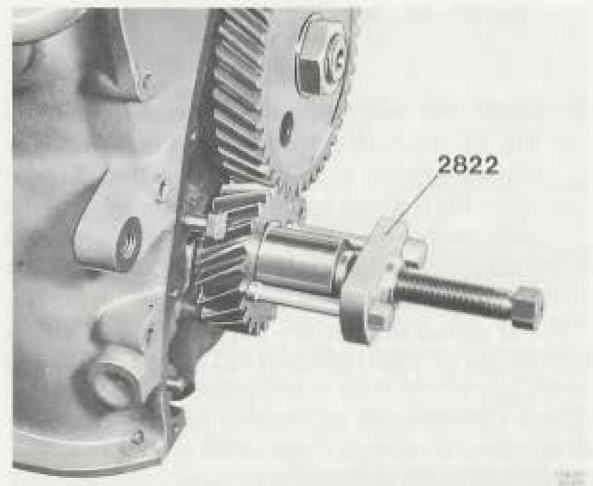
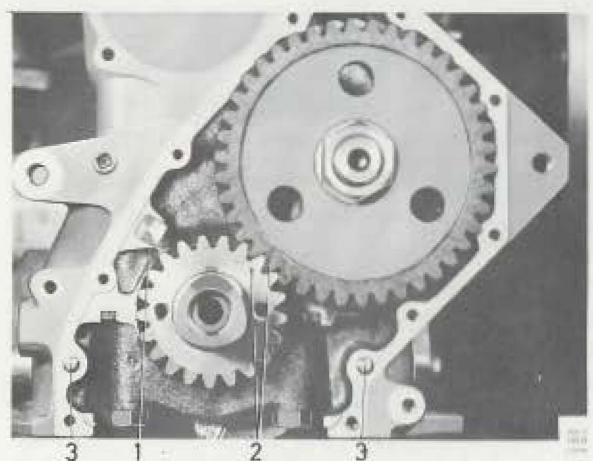

Fig. 21-40. Removing the crankshaft gear



1. Oil nozzle
2. Line-up marks
3. Dowels

Fig. 21-41. Timing gears

5. Install the crankshaft gear with press tool 2815, Fig. 21-42.

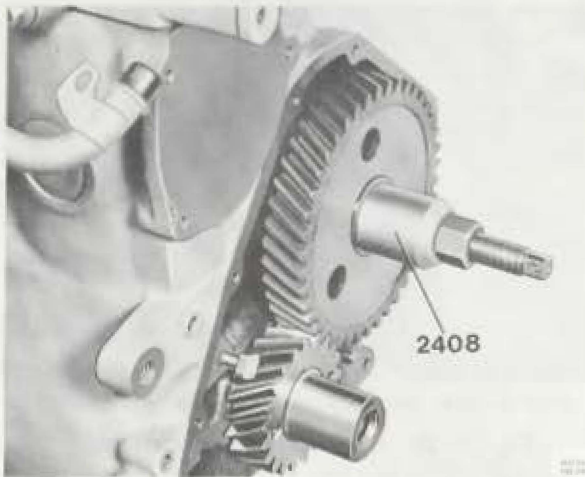

Fig. 21-42. Installing the crankshaft gear

6. Install the camshaft gear with press tool 2408, Fig. 21-43. Both gear wheels should be correctly located relative to each other, see Fig. 21-41. When the marking on the timing gears is opposite each other, then No. 6 piston is at top dead centre, firing position. Do not press the camshaft backwards so that the sealing washer on the rear end comes off. Fit the nut and tighten it to a torque of 130-150 Nm (13-15 kpm = 94-108 lbftf).

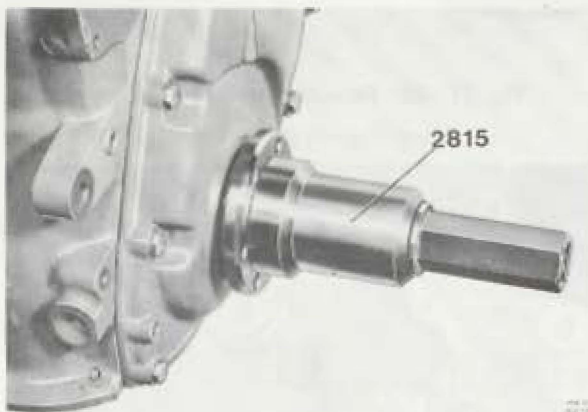

Fig. 21-43. Installing the camshaft gear

7. Check the backlash (0.04-0.08 mm = 0.0016-0.0032") and the camshaft end float (0.02-0.06 mm = 0.0008-0.0024"), which is determined by the spacer washer behind the camshaft gear.
8. Install the timing gear casing. See under "Installing the timing gear casing", page 21:17.

Camshaft

Checking camshaft wear, engine in vehicle

1. Remove the rocker arm casing.
2. Clean the rocker arm casing contact surface against the cylinder head.
3. Zero-set the valve clearance.
4. Turn over the engine until No. 1 cylinder intake valve is fully open and the exhaust valve fully closed.
5. With slide calipers measure the distance between the valve spring washer and the contact surface of the timing gear casing against the cylinder head for both the No. 1 cylinder intake and exhaust valves, Fig. 21-44. Note the measurements.

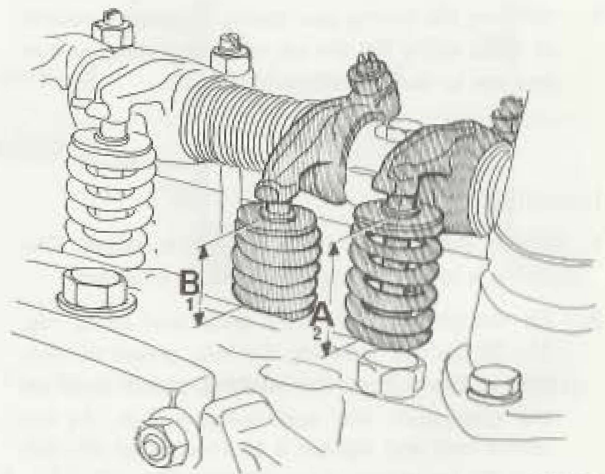

VOLVO
108050

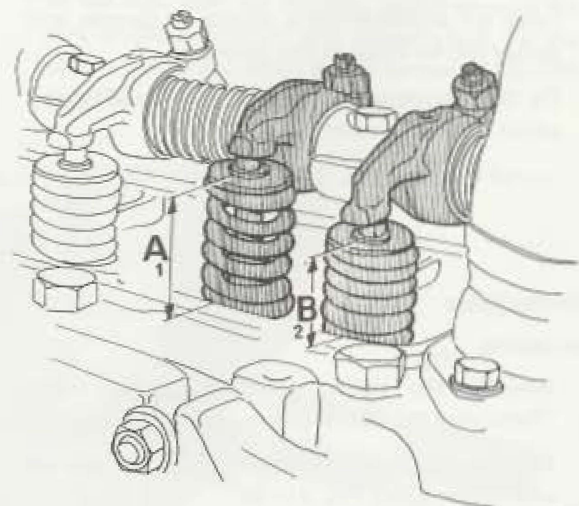

VOLVO
108 049

Valve lift height:
A₁ - B₁ and A₂ - B₂

Fig. 21-44. Checking the camshaft lift height

6. Turn over the engine so that the exhaust valve is fully open and the intake valve fully closed.
7. Measure the distance again between the valve spring washer and the contact surface of the rocker arm cover, for both the valves, Fig. 21-44. Note the measurements.
8. Calculate the lifting height of the valves deducting the measurement for the open valve from the measurement for the closed valve.
9. Measure and calculate correspondingly for the other cylinders. The difference between the maximum and minimum lifting height should not exceed 0.7 mm (0.028").
10. If necessary replace the camshaft.
11. Adjust the valve clearance, which should be 0.40-0.45 mm (0.016-0.018").
12. Install the rocker arm cover.

Removing and checking

1. Remove the cylinder head. See under "Removing the cylinder head", page 21:8.
2. Lift up the valve tappets with tool 2424, Fig. 21-45.



Fig. 21-45. Lifting out valve tappets

3. Remove the fuel pump.
4. Remove the ignition distributor and the distributor pinion.

5. Remove the timing gear casing. See under "Removing the timing gear casing", page 21:17.
6. Remove the camshaft nut and pull off the camshaft gear with puller 2250, Fig. 21-39.
7. Remove the thrust flange and the spacer washer.
8. Take out the camshaft.
9. Check the camshaft for straightness and wear. The out-of-round on the bearing journals may amount to 0.07 mm (0.0028"), providing that the bushings are replaced. The diameter of the bearing journals should be 46.975-47.000 mm (1.8494-1.8504"). If the indicated values are not maintained or if the cams are worn, replace the camshaft.
10. Also check that the camshaft bearings are not excessively worn. Permissible wear up to 0.02 mm (0.0008").

Installing

1. Check that the camshaft has an "A" punched onto the front end.
2. Insert the camshaft in the cylinder block. Install the spacer washer and thrust flange.
3. Install the camshaft gear with press tool 2408, Fig. 21-43. Make sure that the marking on the gears coincide (2, Fig. 21-41). Take care when pressing in the camshaft gear since otherwise the teeth can easily be damaged by the crankshaft gear. Do not press in the camshaft backwards otherwise the sealing washer at the rear camshaft bearing will fall off. Install and tighten up the camshaft nut to a torque of 130-150 Nm (13-15 kpm = 94-108 lbft).
4. Check the backlash (0.04-0.08 mm = 0.0016-0.0032", max. permitted 0.12 mm = 0.0048") and the camshaft end float (0.02-0.06 mm = 0.0008-0.0024"). The end float is determined by the spacer washer behind the camshaft gear.
5. Install the timing gear cover. See under "Installing the timing gear casing", page 21:17.
6. Install the distributor pinion. When the engine is at top dead centre and firing on No. 1 cylinder, install the pinion for the oil pump and distributor. The small end of the groove is faced obliquely upwards-backwards and the groove is set at an angle of about 35° to the longitudinal direction of the engine (see A, Fig. 21-46). Make sure that the shaft goes down into its groove in the pump shaft. (NOTE! When the marking on the timing gears are opposite each other then the No. 6 piston is at top dead centre, firing position.)

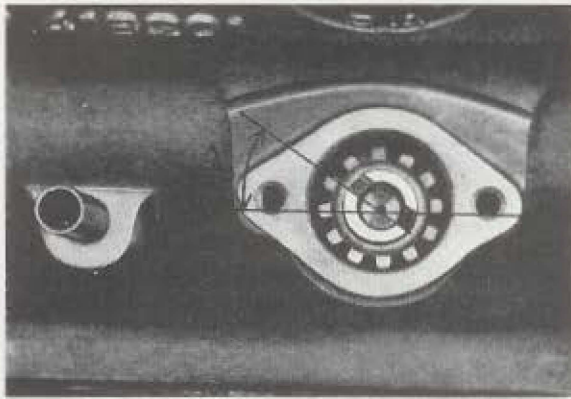

Fig. 21-46. Location of distributor pinion

A = approx 35°

7. Install the valve tappets, with grip tool 2424.
8. Install the distributor and fuel pump.
9. Install the cylinder head. See under "Installing the cylinder head", page 21:8.

Camshaft bearings

Replacing (engine removed)

When the camshaft bearings are worn more than 0.02 mm (0.0008") they should be replaced with new ones. If this work is to be done fully satisfactorily, a drilling machine must be available. When pressing in the new bearings make sure that the lubricating holes are opposite the oil channels in the block.

CRANK MECHANISM

Special tools

1426	Drift
2814	Puller
2815	Press tool
2816	Drift
2817	Tool for pressing sealing ring in and out
4090	Extractor

Crankshaft

Replacing rear crankshaft seal (gearbox removed)

1. Remove the reinforcing bracket.
2. Line-up mark and remove the clutch and fly-wheel.
3. Remove the two oil sump bolts fixed to the sealing flange. Slacken a couple of the oil sump bolts so that the sump does not press against the sealing flange.
4. Remove the sealing flange.

5. Press out the old seal with the drift for tool 2817. Use a suitable cushion for the sealing flange in order not to damage it.
6. Press in the sealing ring with tool 2817, Fig. 21-47. **NOTE!** First inspect the wear surface of the crankshaft. The sealing ring can be installed in three positions with 2817, see Fig. 21-48. With a new crankshaft or with a crankshaft without noticeable wear on the surface, place the sealing in its outer position (centre bolt screwed in fully). With wear marks on the crankshaft, place it with the centre bolt screwed out two threads or screwed out fully.



Fig. 21-47. Pressing in sealing ring

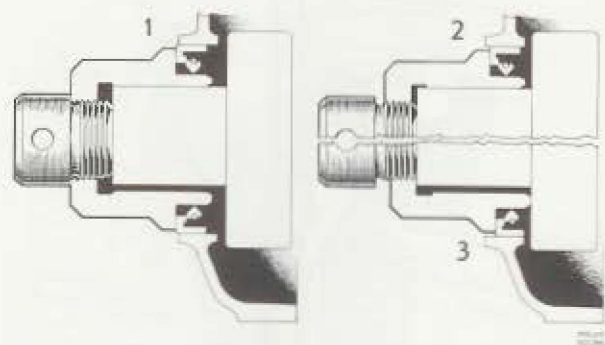

Fig. 21-48. Locations of centre bolt on tool 2817

7. Install the sealing flange with a well-cleaned sealing surface and new gasket. (Oil first the sealing lip.) The sealing flange should be fitted on the crankshaft with due care, see Fig. 21-49. Fit on the sealing lip with a finger.

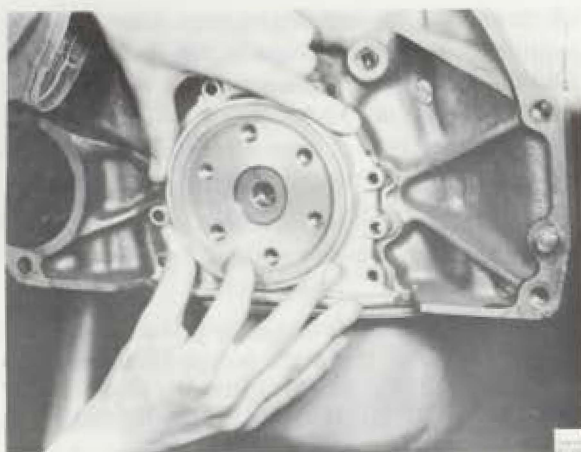

Fig. 21-49. Installing the sealing flange

8. Install the oil sump bolts.
9. Install the flywheel and clutch. Note the line-up marks, see point 1.
10. Install the reinforcing bracket.

Removing the crankshaft (engine removed)

1. Line-up mark and remove the clutch and flywheel.
2. Remove the oil sump, sealing plate and oil pump.
3. Slacken the drive belts. Remove the crankshaft pulley and vibration damper.
4. Screw out the centre bolt and pull off the polygon hub with puller 2814, Fig. 21-50. (But first try to see that the hub can be pulled off by hand.)

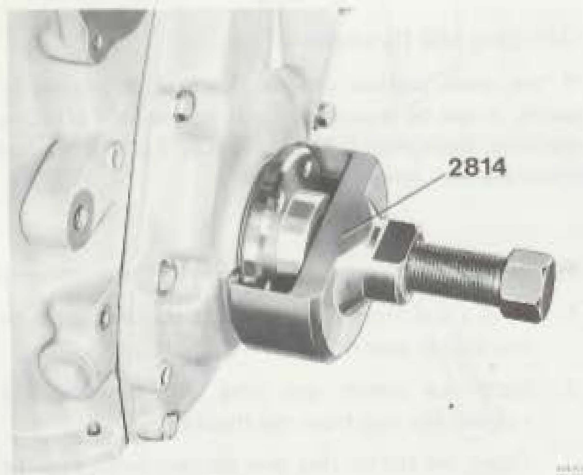

Fig. 21-50. Removing the polygon hub

5. Remove the timing gear casing and the rear sealing flange.
6. Remove the caps for the big-end and main bearings.
7. Lift out the crankshaft.

Checking

After cleaning the crankshaft measure its journals with a micrometer. Measure at different points round the circumference and on the length. Out-of-roundness on the main bearing journals may not exceed 0.05 mm (0.0020"), and that on the connecting rod journals 0.07 mm (0.0028"). Taper may not be greater than 0.05 mm (0.0020") for any of the journals.

If the measurements are close to or exceed the wear indicated above, grind the crankshaft to undersize. Suitable bearing shells are available in 2 undersizes. Concerning measurements, see the data on page 20:4.

Check that the shaft is straight within 0.05 mm (0.0020") by means of a dial indicator. Place the shaft in two V-blocks and place a dial indicator on the centre journal and then rotate the shaft. If necessary straighten the shaft in a press.

Grinding

Before being ground, the crankshaft must be straight. This should be checked according to the previous paragraph. Grinding is carried out in a special machine and the main bearing and big-end bearing journals are ground to similar measurements. These measurements, which are indicated in the data given on page 20:4, must be accurately followed in order to get the correct bearing clearance with the ready-machined bearing shells.

Under no circumstances whatsoever may the bearing shells be shaved or the caps filed.

The journal fillets should be 2.0-2.5 mm (0.08-0.10") for all journals, Fig. 21-51. The width measurement (A) for the pilot bearing will depend on the size of the journal and should be ground so that the correct measurement is obtained. After the grinding the oil channel openings should be carefully cleaned and all journals lapped with a fine lapping paste to best surface finish, after which the shaft is washed. Clean all oil channels with particular thoroughness in order to remove all residues of filings and grinding paste.

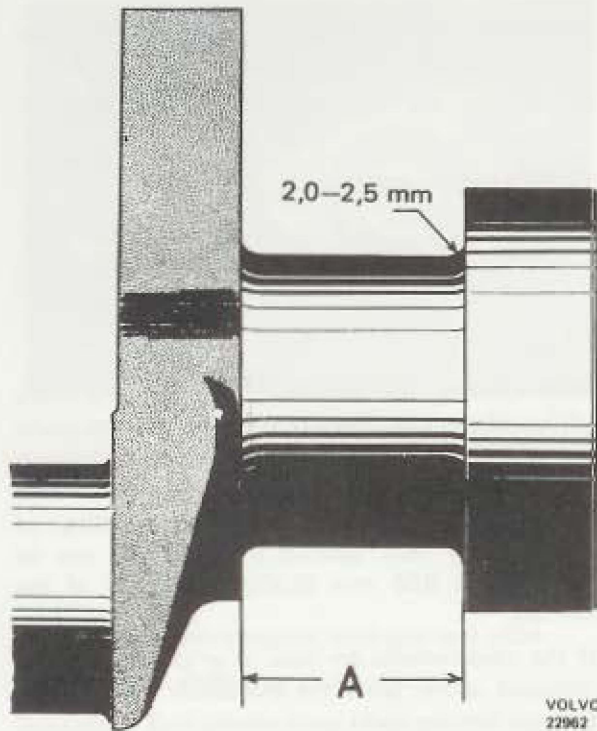

Fig. 21-51. Bearing journal

Installing

1. Clean all the bearing seats and fit bearing shells with the correct size.
In addition to the standard size, there are bearing shells available with undersizes 0.010" and 0.020". The rear main bearing shells are provided with flanges and have a wider width in relation to the size. If the crankshaft has been ground to the correct measurement, the correct bearing clearance will be obtained when the corresponding bearing shell is fitted. The bearing shells must not be shaved and the caps must never be filed in order to get a tighter fit for the bearings.
2. Oil the bearing shells and carefully install the crankshaft in position.
Note the line-up marks on the timing gears.
3. Install the lower main bearing shells in the caps and oil them.
4. Install the main bearing caps. Tighten the bolts in stages to a torque of 120-130 Nm (12-13 kpm = 87-94 lbftf). Between tightenings turn over the crankshaft and check that it does not jam.
5. Measure the crankshaft end float which should be 0.037-0.147 mm (0.0015-0.0058").
6. Install the big-end bearings in the caps and oil them.

7. Install the big-end bearing caps. Make sure that the caps are fitted properly. New bolts and nuts should be used. Tighten the nuts to a torque of 63-70 Nm (6.3-7.0 kpm = 45-51 lbftf). Check to make sure that there is end float and that no bearing shows a tendency to jam.
8. Install the rear sealing flange, with new gasket and sealing ring. See under "Replacing the rear crankshaft seal", on page 21:20.
9. Replace the timing gear cover gasket and seal and fit the cover. Install the polygon hub with press tool 2815, Fig. 21-52. Install the vibration damper and crankshaft pulley. Install the drive belts and the adjust the belt tension.

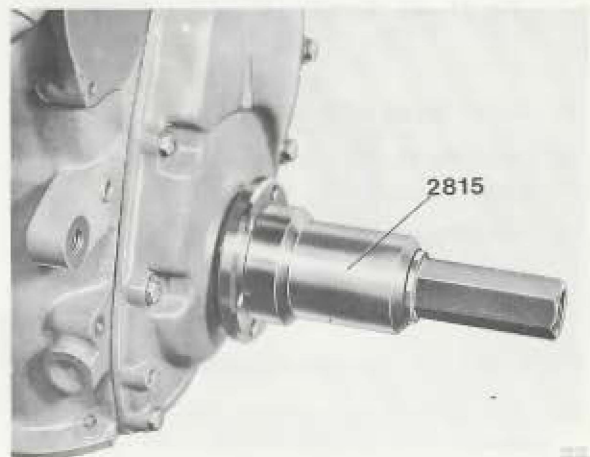

Fig. 21-52. Installing the polygon hub

10. Install the oil pump, sealing plate and oil sump with new gasket. The "tongue" on the oil sump gasket should face the starter motor flange.
11. Install the flywheel and clutch. Note the line-up marks for these components, see point 1 "Removing".

Grinding the flywheel

If the wear surface on the flywheel is uneven or burnt, it can be ground smooth on a saddle grinding machine. More than 0.75 mm (0.030") of the original thickness may not be ground off.

Replacing starter gear ring (Flywheel removed)

1. Drill a \varnothing 6 mm (1/4") hole in a tooth opening on the starter gear ring.
2. Split the starter gear ring with a chisel and remove the ring from the flywheel.
3. Clean the starter ring gear contact surface on the flywheel.
4. Polish the starter gear ring at three points.

5. Heat the ring with a welding flame. Spread the heat evenly all round. Discontinue the heating when the polished surfaces become blue. **Note!** Be careful not to overheat the ring otherwise it might warp.
6. Place the starter gear ring on the flywheel and drive it into position with a copper drift or similar tool. The bevel on the ring should face forwards.
7. Allow the ring to cool in the open air.

Replacing the pilot bearing for the input shaft (Gearbox removed)

1. Make line-up marks on the clutch and remove the clutch.
2. Remove the bearing circlip and protective washer and pull out the bearing with puller 4090.
3. Check the bearing after having cleaned it in white spirit. Replace it if it is worn.
4. Pack the bearing with heat-resistant ball bearing grease.
5. Install the bearing with drift 1426.
6. Install the protective washer and circlip.
7. Install the clutch. Note the line-up marks, see point 1.

Replacing the rear engine mount

VOLVO
100 746

Fig. 21-53 Rear engine mount

Replacing the front engine mount

VOLVO
100 746

Fig. 21-54. Front engine mount

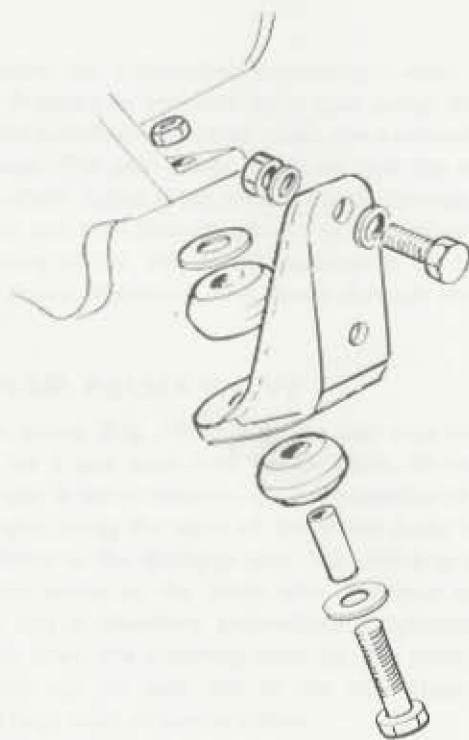
GROUP 22 LUBRICATING SYSTEM

Description

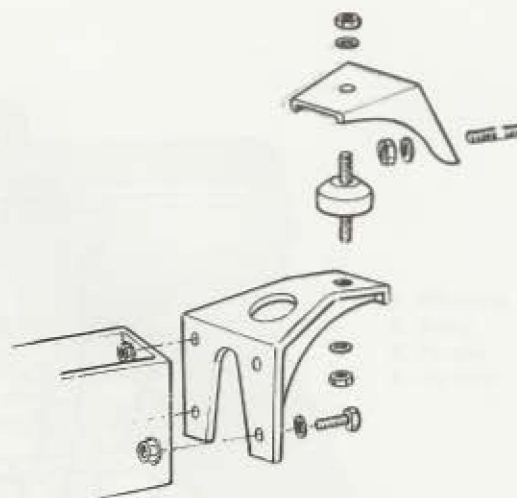
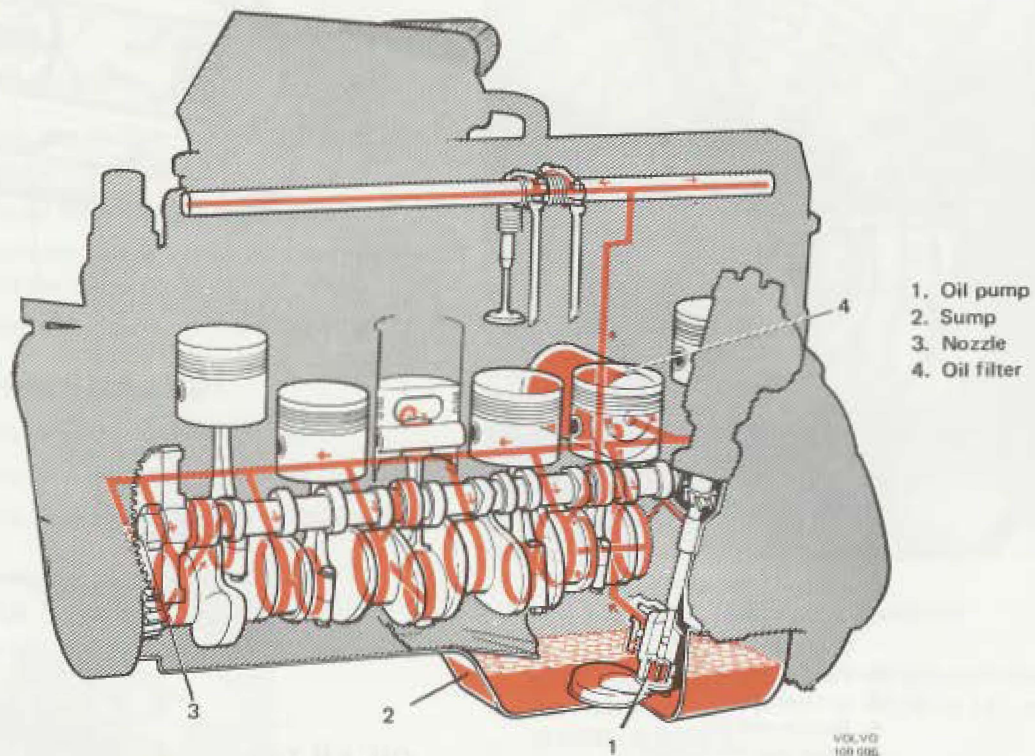

Fig. 22-1. Lubricating system

The engine has a force-feed lubricating system, Fig. 22-1. Pressure is provided by a gear pump driven from the camshaft and fitted under the crankshaft in the sump. The gear pump forces oil past the relief valve, which is also fitted on the pump, through the oil filter and then through oilways out to the various lubricating points. All the oil supplied in the lubricating points, therefore, first passes through the oil filter.

OIL PUMP, RELIEF VALVE

The oil pump (Fig. 22-2) is of the gear type and is driven via a gear train from the camshaft. When the pump gear is set in rotation, oil is transported to the tooth gaps along the walls of the pump body from the suction to the discharge side. The discharge pipe from the pump to the block does not have screw unions and is, therefore, automatically tightened in position when the attaching bolts for the pump are tightened up. At each end of the pipe there are sealing rings made of special rubber.

The relief valve is located in the pump and consists of a spring-loaded ball which seals against a seat in the pump body.

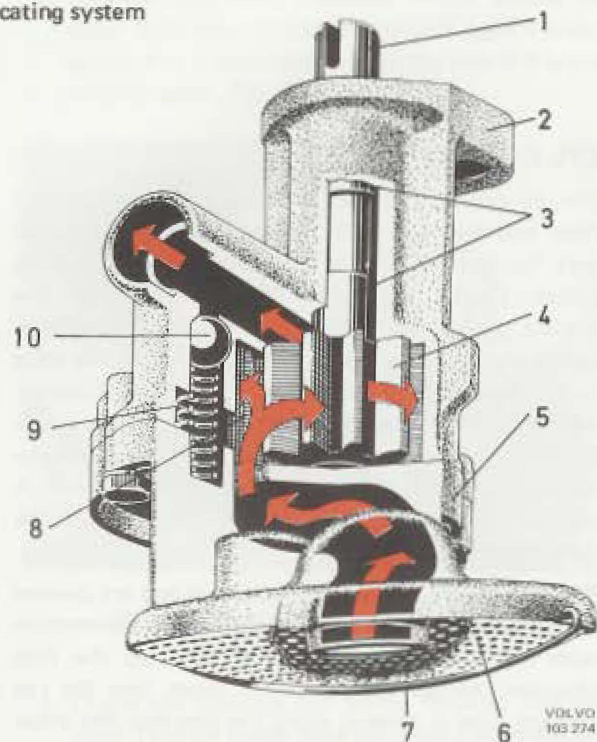

Fig. 22-2. Oil pump

- | | |
|-----------------|----------------------------|
| 1. Drive shaft | 6. Strainer |
| 2. Pump body | 7. Retainer clip |
| 3. Bushings | 8. Driven gear |
| 4. Driving gear | 9. Spring for relief valve |
| 5. Cover | 10. Valve ball |

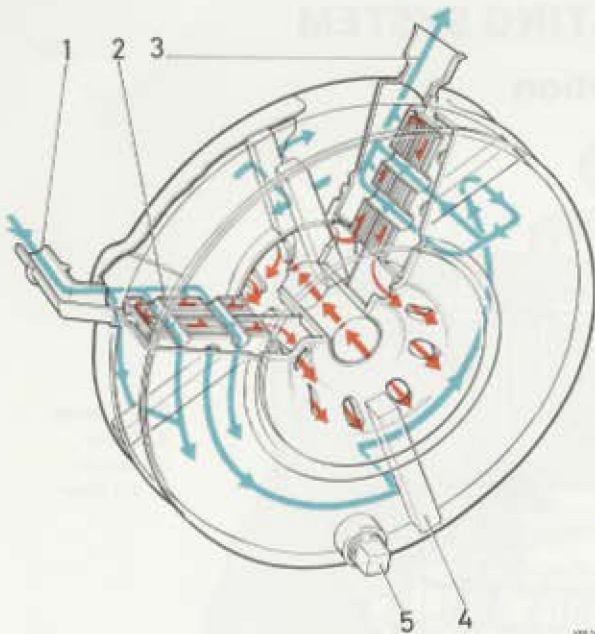

Fig. 22-3. Oil cooler

1. Coolant inlet
2. Fins
3. Coolant outlet
4. Rubber seal
5. Drain plug for coolant

OIL COOLER

The oil cooler (Fig. 22-3) is fixed between the oil filter and the cylinder block and consists of an inner part for the oil, which is surrounded by a cooling jacket. Engine coolant is conducted through the cooling jacket. Since the oil on its way to the filter passes the oil cooler some of the heat from the oil is cooled by means of the coolant. The coolant cannot go the shortest route from the inlet (1) to the outlet (3) but is forced to take a zig-zag path and round the radiator as shown by the blue arrows (Fig. 22-3). A number of rubber seals (4) force the fluid to take this definite route.

The fins (2) are cooled by the coolant and are divided by a plate into two chambers which are in connection with the fin periphery. Oil comes into the first chamber, nearest to the engine block (see the red arrows), and is pressed along the fins into the other chamber and along its fins. From there it continues on into the oil filter.

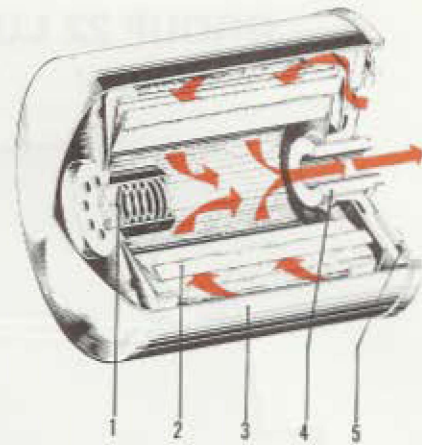

Fig. 22-4 Oil filter

1. Overflow valve
2. Element
3. Body
4. Nipple
5. Gasket

OIL FILTER

The oil filter (Fig. 22-4), which is made as a single unit complete with element, is of the full-flow type and is screwed directly onto the cylinder block. Oil fed out to the various lubricating points in the engine first passes through the oil filter element which is made of special paper. In the oil filter there is a by-pass valve which allows the oil to by-pass the element if resistance to flow should become excessive. When blocked so that it has to be replaced, remove and discard the old filter and fit a new one.

Service Procedures

OIL PUMP

Removing

1. Drain the engine oil.
2. Remove the reinforcing bracket between the flywheel casing and cylinder block.
3. Remove the oil sump and the sealing plate.
4. Remove both the retaining bolts for the oil pump and take off the pump and discharge pipe.
5. Pull the discharge pipe loose from the oil pump.

Checking and reconditioning

1. Remove the lock clasp and the strainer.
2. Remove the retaining bolts and lift off the cover.
3. Lift out the gears and relief valve spring and ball.

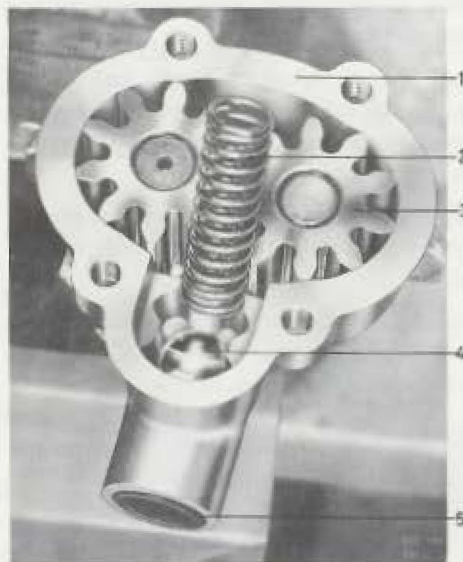

Fig. 22-5. Oil pump

1. Pump body
2. Spring for relief valve
3. Gear
4. Valve ball
5. Hole for oil pipe

4. Clean all parts.
5. Check the relief valve seat, ball and spring. Test the spring in a spring tester. Unloaded it should be 39 mm (1.5") in length, loaded with 50 ± 4 N (111 ± 9 lbf) it should be 26.25 mm (1.0") and loaded with 70 ± 8 N (154 ± 18 lbf) it should be 21 mm (0.8") in length.
6. Check to see whether the gear flanks, tops or ends are worn. Replace damaged or worn gears. Check that the backlash is 0.15–0.25 mm (0.006–0.010"), Fig. 22-6.



Fig. 22-6. Measuring the backlash

7. Check that the radial clearance between tooth top and pump body is 0.08–0.14 mm (0.0031–0.0055").
8. Measure the axial clearance which should be 0.02–0.10 mm (0.0008–0.0039") with a feeler gauge, and a new cover or the old one if it is not notably worn, Fig. 22-7.



Fig. 22-7. Measuring the axial clearance

9. Check the bushings and shafts. (NOTE! The late prod. type oil pump does not have any bushings.) If necessary replace them with new ones. The drive shaft and gear wheel are replaced as a single unit. After being pressed in, the new bushings should be reamed with a guided reamer.
10. Assemble the oil pump.

Installing

The sealing rings at the ends of the discharge pipe are made of special rubber with close tolerances. Use only genuine Volvo parts.

1. Fit the sealing rings on the discharge pipe and insert the pipe in its proper position in the oil pump.
Before being installed, the rings can be coated with soapy water in order to facilitate installation of the pipe. If necessary tap lightly on the pipe with a soft mallet.
2. Install the oil pump and discharge pipe in the cylinder block, Fig. 22-8. The pump connection flange should be flush with the block before being tightened up.

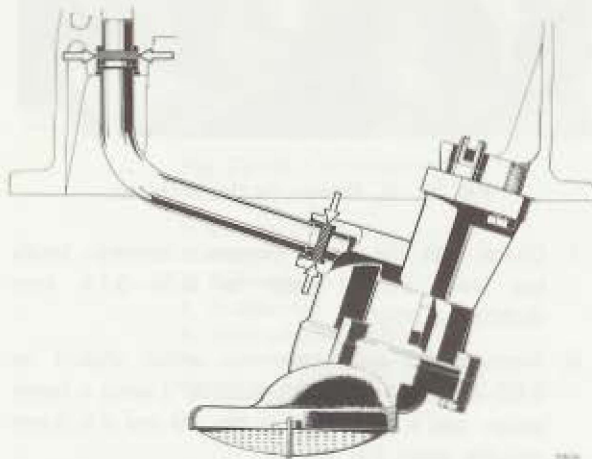

Fig. 22-8. Sealing rings on discharge pipe

3. If necessary replace the oil sump gasket. The "tongue" on the gasket should face the starter motor flange.
4. Install the sealing plate and oil sump.
5. Install the reinforcing bracket and tighten the bolts by hand. Do not forget the spacer washers on the front retaining bolts, between the bracket and cylinder block. Then tighten up the bolts against the clutch casing and thereafter the bolts against the cylinder block.
6. Fill with engine oil.
7. Start the engine and check for oil leakage.

Replacing the oil cooler

1. Drain the coolant by opening the drain cock on the lower radiator pipe running from the engine and remove the plug in the oil cooler.
2. Remove the oil filter. Use tool 2903 or similar, e.g., chain tongs.
3. Remove the clamps holding the coolant pipes together under the manifold.
4. Unscrew the nut from the nipple in the centre of the oil cooler.
5. Remove the coolant pipe from the oil cooler and pull the oil cooler from the nipple.
If the nipple is replaced, the new nipple should be tightened to a torque of 45–55 Nm (4.5–5.5 kpm = 33–40 lbfft).
6. Fit the new sealing washers for the coolant pipe connections. The groove for the sealing ring in the oil cooler should be coated with a light layer of glue, resistant to oil up to 140°C (284°F) (e.g. Pliobond). Install the sealing ring.
7. Install the oil cooler on the nipple in the cylinder block and fit the nut. Tighten the nut to a torque of 10 Nm (1 kpm = 7 lbfft) and check that the oil cooler is tight against the cylinder block. Then tighten the nut to a torque of 30–35 Nm (3.0–3.5 kpm = 22–25 lbfft).
8. Install the coolant pipe.
9. Clamp the coolant pipes in position, 2 clamps under the manifold.
10. Screw on the oil filter by hand until it just touches the oil cooler. Then screw it a further half turn. Tools must not be used for this purpose.
11. Fill with engine oil, 1/2 litre (1 pint) for the oil cooler and if necessary 1/2 litre (1 pint) for the oil filter.
12. Close the drain cock on the lower radiator pipe and fit the plug in the oil cooler. Fill with coolant through the opening on the radiator, the heater control should be at MAX. Fill the radiator fully and put on the cap. Also fill the expansion tank to the MAX. mark.
13. Start the engine and check for leakage.

Replacing the oil filter

Together with the insert and overflow valve, the oil filter forms a single unit screwed on to a nipple which is attached to the cylinder block. When replacing, scrap the old oil filter. Replacement is as follows:

1. Remove the oil filter with tool 2903 or similar, e.g., chain tongs.
2. Apply oil to the new oil filter rubber gasket and make sure that the contact surface is free from dirt.
3. Screw on the new oil filter until it just touches the oil cooler. Then screw the filter a further half turn. Tools are not to be used for this purpose.
4. Fill with 1/2 litre (1 pint) engine oil.
5. Start the engine and check for leakage at the joints.

GROUP 23 FUEL SYSTEM

Description

CARBURETTORS

The engine is fitted with two horizontal carburetors of type Stromberg 175 CD-2SE. The design and construction can be seen from Figs. 23-1, 23-2, 23-3 and 23-4.

The carburettor consists of three main parts of light-alloy, the middle part of which comprises the carburettor housing. The lower section is made up of a floatchamber, which houses the jet and the float. The upper section consists of a suction chamber cover, which forms a suction chamber together with a diaphragm fixed in the air valve. The suction chamber regulates the air valve lift and thereby the location of the needle in the jet. The suction chamber is linked by means of channels in the valve to the space between the carburettor throttle and valve.

The carburetors are provided with a fixed jet pressed into the carburettor housing. The fuel flow orifice area of this jet is varied by means of a movable tapered needle. The position of the needle is deter-

mined by the carburettor housing vacuum operating an air valve in which the needle is fitted in a spring-loaded suspension. The spring force always presses the needle against the same side of the jet, and this ensures an accurately controlled fuel flow through the jet. Both carburetors are fitted with a temperature compensator (6, Fig. 23-2 and 2, Fig. 23-4). This is constructed as an air valve regulated by the carburettor temperature and maintains the fuel-air mixture constant irrespective of the fuel temperature.

The throttle spindles are provided with seals to reduce wear on the spindles and bushings and also to eliminate any air leakage.

The hot-start valve is described on page 23:5.

The front carburettor has a vacuum connection for positive advance setting of the ignition distributor. The rear carburettor is provided with a cold-start device.

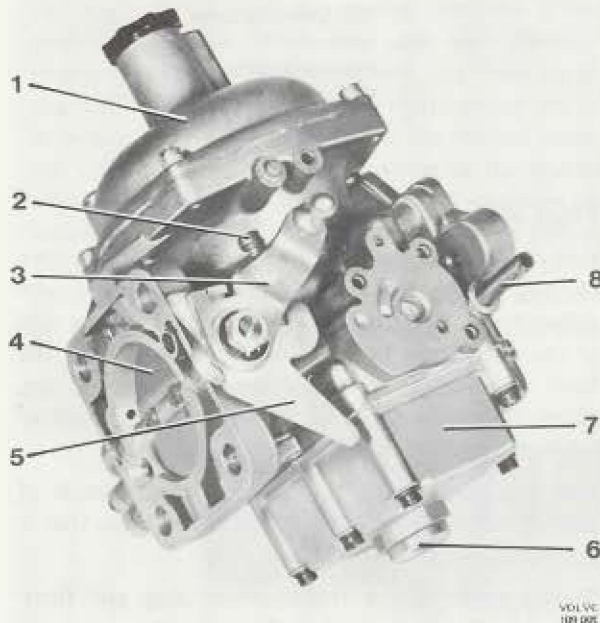

Fig. 23-1. Front carburettor, from left

1. Suction chamber
2. Throttle stop screw
3. Lever
4. Primary throttle
5. Throttle spindle cam (for regulating secondary throttle)
6. Floatchamber plug
7. Floatchamber
8. Fuel inlet

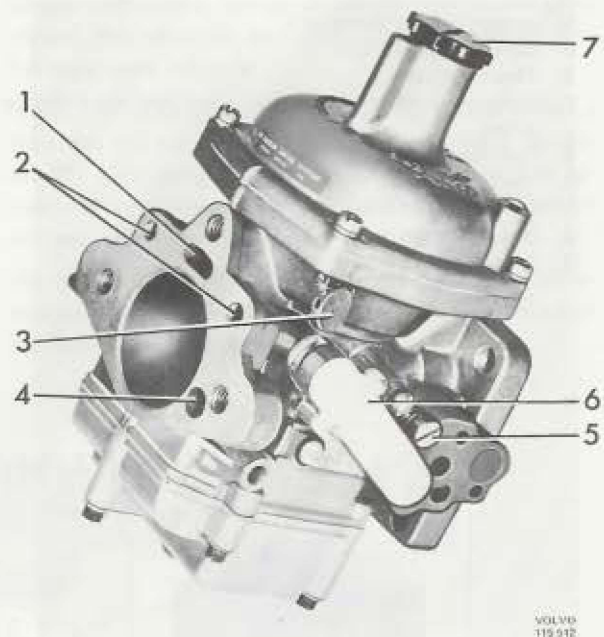

Fig. 23-2. Front carburettor, from right

1. Drilling for air supply under diaphragm
2. Venting channels from floatchamber
3. Sealed plug
4. Drilling for air supply to temp. comp. and idle trimming screw
5. Idle trimming screw
6. Temperature compensator
7. Hydraulic damper

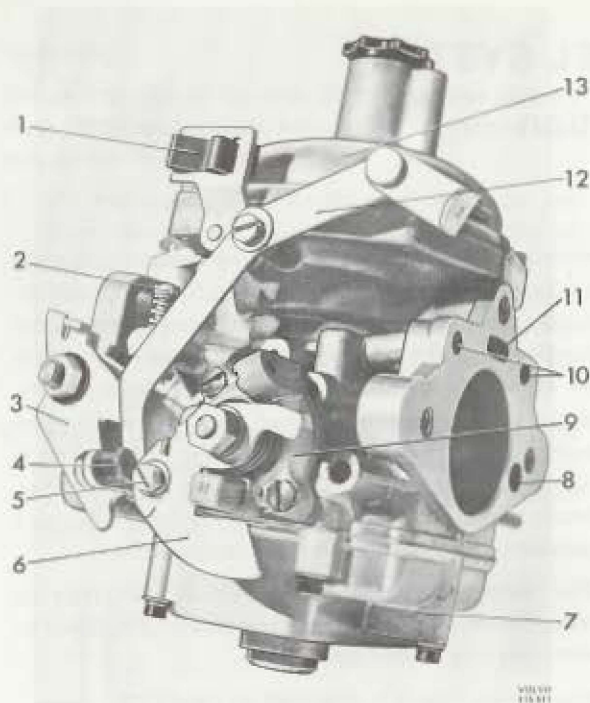

Fig. 23-3. Rear carburettor, from left

1. Clamp for choke wire
2. Throttle stop screw
3. Throttle spindle cam
4. Fast idle stop screw
5. Connection for choke wire
6. Cam disc for fast idle
7. Floatchamber
8. Drilling for air supply to temp. comp. and idle trimming screw
9. Cold-start device
10. Venting channels from floatchamber
11. Drilling for air supply under diaphragm
12. Hot start valve control
13. Suction chamber



Fig. 23-4. Rear carburettor, from right

1. Sealed plug
2. Temperature compensator
3. Fuel inlet
4. Idle trimming screw
5. Lever
6. Primary throttle
7. Connection for vacuum hose
8. Hydraulic damper

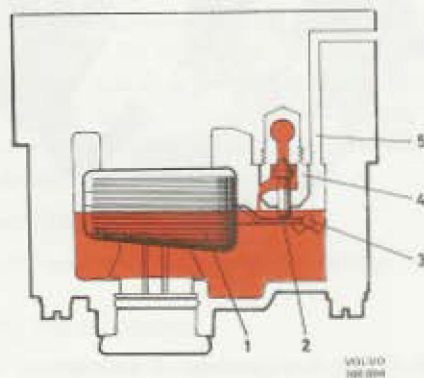

Fig. 23-5. Float system

1. Float
2. Float arm
3. Float shaft
4. Float valve
5. Venting channel from floatchamber to air cleaner

Float system

Fuel flows into the floatchamber via the float valve (4, Fig. 23-5). The float, which is made up of twin nylon floats, is carried on a bridge on the lower side of the carburettor housing. As the fuel level rises, the float lifts and, by means of the float arm and tag, closes the needle on its seating when the correct level has been reached.

The fuel rises in the fuel jet pipe to the inside of the jet, where the level becomes the same as that in the floatchamber.

Sealing between the floatchamber plug and floatchamber is in the form of an O-ring.

Cold start device and fast idle

To make starting easier during cold weather, the rear carburettor is fitted with a cold start device (9, Fig. 23-3).

The cold start device consists of a valve disc (3, Fig. 23-6) provided with four calibrated holes and an elongated opening as well as a disc (4) mounted on a spindle which is operated by the choke. Outside the

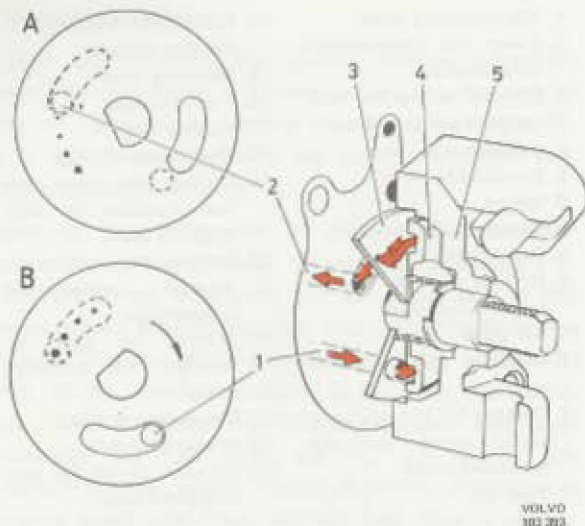

Fig. 23-6. Cold start device

- A. Cold start device, disengaged
 B. Cold start device, engaged
 1. From floatchamber
 2. To ventury
 3. Valve disc
 4. "Channel Disc"
 5. Housing

housing (5) on the same spindle, there is a cam disc (6, Fig. 23-3) with connection for the choke control pull wire. When the cold start device is engaged, the valve disc turns and this links up the channel (1, Fig. 23-6) from the floatchamber via one or several of the calibrated holes to the channel behind the valve disc and then the opening to the channel which terminates in the ventury (2) between the vacuum plunger and choke flap. Through this link-up, the engine receives extra fuel (richer mixture), to facilitate cold starts. At the same time a small supply of air is also obtained through the choke device. When

the choke is pushed in, the valve disc turns and closes the inlet to the channel. At the same time the cam disc is operated, the throttle flap opening is also influenced in such a way that turning the cam disc opens the throttle through the fast idle stop screw (4, Fig. 23-3) and the lever, before any of the calibrated holes open the connection to the fuel drilling. Thanks to this arrangement, the idling speed can if necessary be raised by the driver of the vehicle during the warming-up period of the engine.

Exhaust emission control system

The engine is fitted with an exhaust emission control system in accordance with the principle of a more complete combustion which reduces the contents of carbon monoxide and hydrocarbons in the exhaust gases to an acceptable level. This is achieved mainly by a modified induction system that enables a more exact and leaner mixture ratio between fuel and air to be used.

How the system works is illustrated in Fig. 23-7.

The intake manifold is fitted with a secondary throttle (3) at each carburettor. For normal driving, (with low power output) the throttles (3) are closed thus forcing the mixture of fuel and air from the carburettors to a central pre-heating chamber (6) where the intake charge is heated and thoroughly mixed, this resulting in a completely evaporated and homogeneous mixture.

When higher output is required, that is, the primary throttles (4) are opened wider, the secondary throttles (3) also open and the mixture of fuel and air passes from the carburettors directly to the cylinders without going through the pre-heating chamber.

No particularly accurate synchronizing of the carburettors is required since they are linked to each other through the intake manifold.

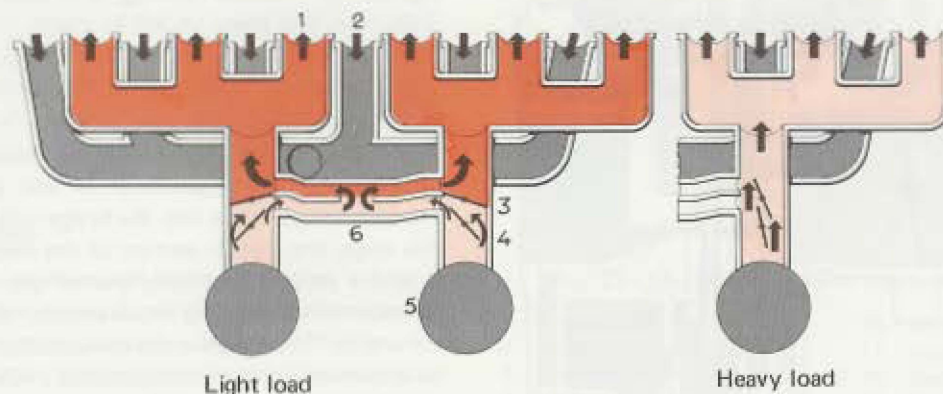

Fig. 23-7. Exhaust emission control system, principle of operation

1. Intake manifold
 2. Exhaust manifold
 3. Secondary throttle
 4. Primary throttle
 5. Carburettor
 6. Pre-heating chamber

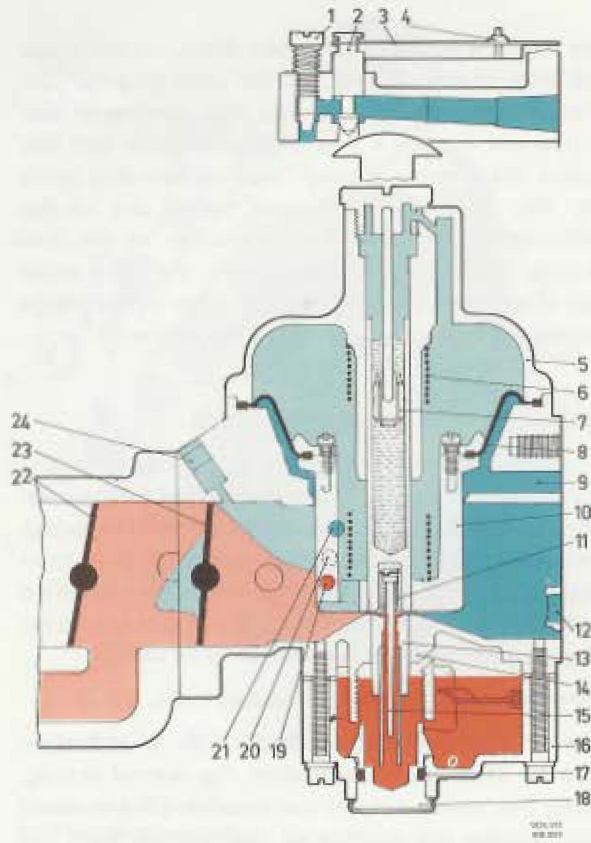

Fig. 23-8. Cold starting, principle

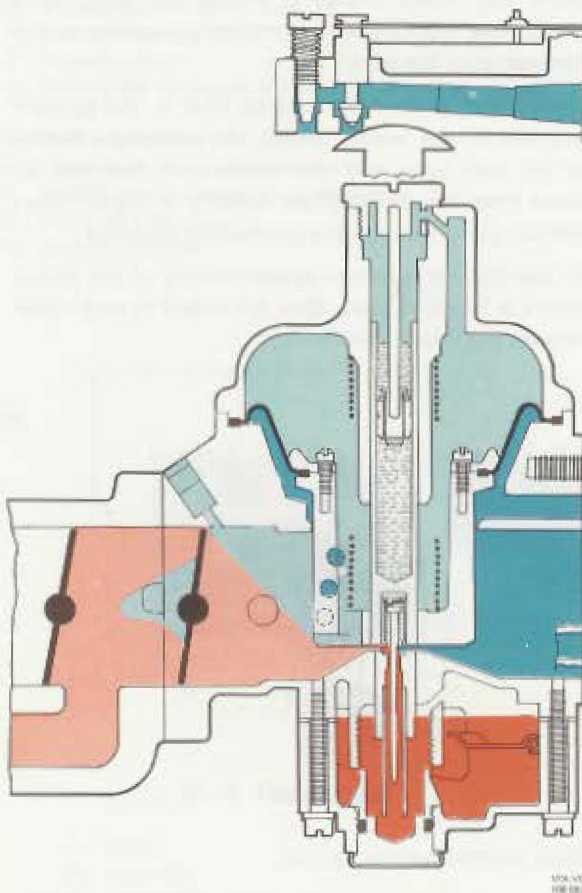

Fig. 23-9. Idling engine

- | | |
|--|---|
| 1. Idle trimming screw | 14. Carburettor housing (middle section) |
| 2. Valve for temperature compensator | 15. Metering needle |
| 3. Bi-metal spring for temperature compensator | 16. Floatchamber |
| 4. Adjuster nut | 17. Rubber ring |
| 5. Suction chamber | 18. Floatchamber plug |
| 6. Spring | 19. Drilling for cold start fuel (located in carb. opposite wall) |
| 7. Damper plunger | 20. Drilling for extra air through temperature compensator |
| 8. Diaphragm | 21. Drilling for extra air through idle trimming screw |
| 9. Drilling for air supply under diaphragm | 22. Secondary throttle |
| 10. Air valve | 23. Primary throttle |
| 11. Metering needle suspension | 24. Vacuum outlet for ignition distributor |
| 12. Drilling for air supply to temp. comp. and idle trimming screw | |
| 13. Fuel jet | |

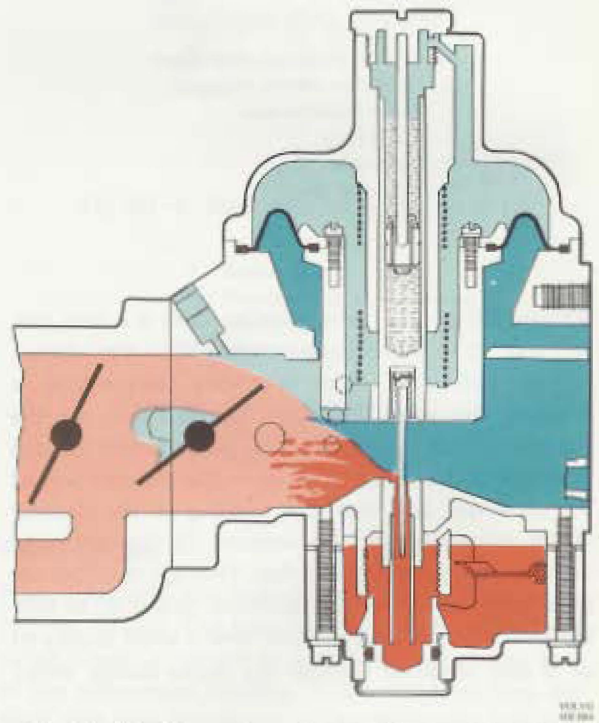

Fig. 23-10. Normal running, with secondary throttle open

Idling

When the engine is idling, the vacuum in the carburettor suction chamber is low and the gap between the air valve and the bridge will be small. At this stage, the thicker section of the metering needle is in the jet and thus only a small quantity of fuel, corresponding to idling requirements, is sucked into the engine. The temperature compensator is regulated by a bi-metal spring which actuates a valve. When the engine is hot and the temperature in the carburettor rises, the valve opens and air is supplied to the carburettor ventury to compensate for the increase in the fuel flow, which is obtained due to the alteration in the fuel's viscosity, see Fig. 23-9.

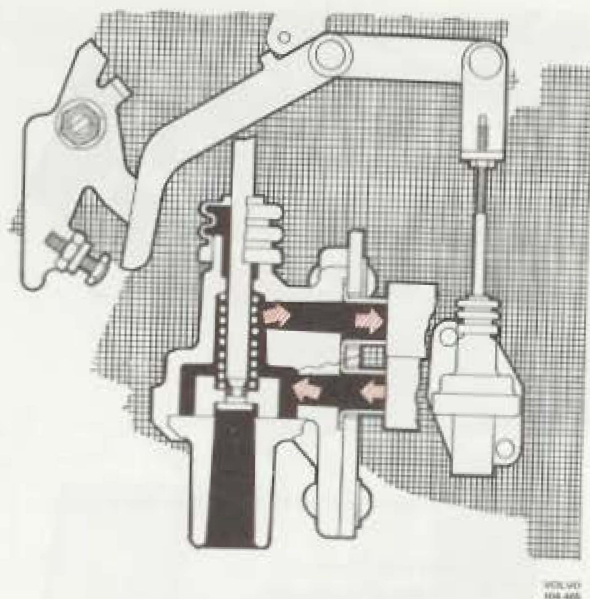

Fig. 23-13. Hot start valve function, driving

When the accelerator pedal is depressed, the throttle control lever (1, Fig. 23-13) breaks contact with the valve control and the piston (14) is pressed by the spring (15) to its bottom position. The outlet (12) is shut off, fuel fumes are led into the air cleaner, and when the engine starts running, these fumes are led further through the carburettor and into the engine combustion chambers.

AIR CLEANER

The air cleaner functions both as a cleaner for the intake air and as an intake silencer.

It is provided with a replaceable paper insert of the so-called "rod type". This insert must not be washed or moistened. The only servicing required is replacement with a new one.

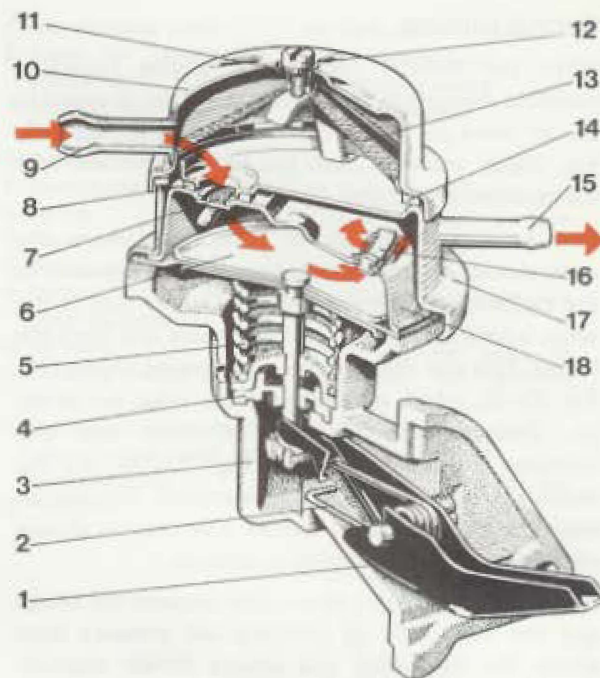

Fig. 23-14. Fuel pump, Pierburg

- | | |
|--------------------|---------------------|
| 1. Rocker arm | 10. Cover |
| 2. Spring | 11. Washer |
| 3. Lower pump body | 12. Screw |
| 4. Seal | 13. Filter |
| 5. Spring | 14. Sealing ring |
| 6. Diaphragm | 15. Outlet |
| 7. Inlet valve | 16. Outlet valve |
| 8. Sealing ring | 17. Upper pump body |
| 9. Inlet | 18. Valve housing |

FUEL PUMP

The fuel pump is of the diaphragm type and is driven by a cam on the camshaft. When the rocker arm in the pump is pressed upwards by the cam, the diaphragm is pulled downwards and fuel is drawn up to the pump. When the rocker arm returns, the diaphragm is pressed upwards by a spring (5, Fig. 23-14) and fuel is fed to the floatchamber in the carburettor. When the level in the floatchamber is sufficiently high, the float valve closes and the pressure in the discharge line rises until the pressure on the upper side of the diaphragm exceeds the spring pressure and pumping ceases.

Two alternative fuel pumps are used. One comes from Pierburg (Fig. 23-14) and the other is a S.E.V. make (Fig. 23-15).

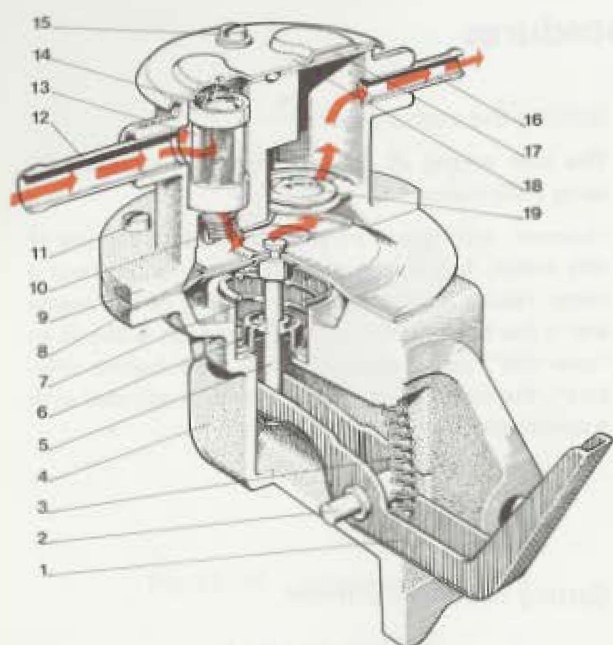

Fig. 23-15. Fuel pump, S.E.V.

- | | |
|--------------------|------------------|
| 1. Lever | 11. Screw |
| 2. Shaft | 12. Inlet |
| 3. Spring | 13. Filter |
| 4. Lower pump body | 14. Spring |
| 5. Thrust rod | 15. Screw |
| 6. Seal | 16. Outlet |
| 7. Spring | 17. Seal |
| 8. Diaphragm | 18. Cover |
| 9. Upper pump body | 19. Outlet valve |
| 10. Inlet valve | |



Fig. 23-16. Fuel filter

FUEL FILTER

The fuel filter is fixed to the front of the cylinder block by means of brackets, see Fig. 23-16. It is provided with a replaceable ceramic insert.

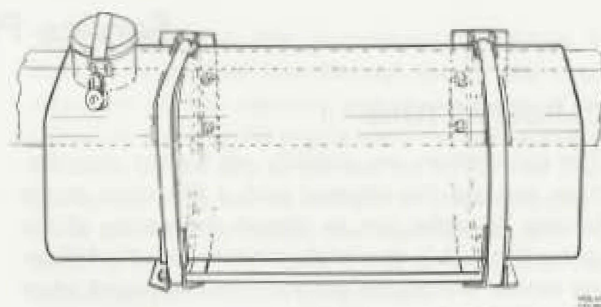

Fig. 23-17. Fuel tank

FUEL TANK AND FUEL LINES

The filler pipe is provided with a strainer to prevent impurities getting into the fuel tank.

Concerning the tank level gauge unit, see Part 3, Group 38.

Service Procedures

CARBURETTORS

The carburetors are specially set by the manufacturer and are fine-adjusted with a CO-meter at the factory. In order not to disturb the setting of the carburetors, it is absolutely essential that the following service procedures are accurately followed when any work is to be done on the carburetors.

Periodical Check

Check regularly to see that there is oil in the damper cylinders (Fig. 23-18). The spindle in the piston should be filled to about 1/4" from the upper edge with oil approved as "Automatic Transmission Fluid". **NOTE!** The damper cylinders must not be filled with engine oil.

Before any adjustment or repairs to the carburettor are carried out, the following should be checked and, if necessary, remedied:

Valve clearance, spark plugs, compression, ignition contact breaker (dwell angle) and ignition setting. Also check that there is no air leakage on the intake side and that the air cleaner is not blocked. The function of the throttle controls should be checked as well.

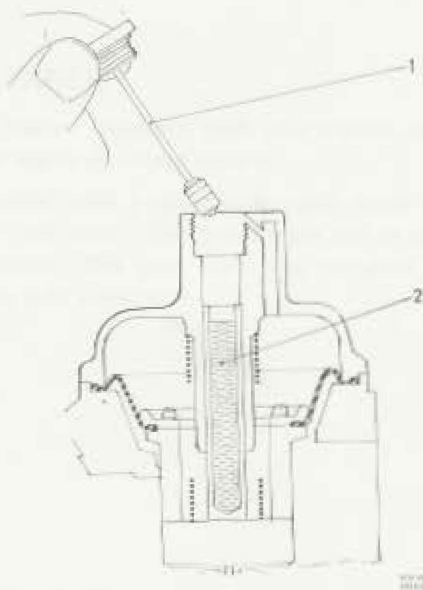

Fig. 23-18. Checking the damper oil level

1. Damper plunger
2. Damper oil (Automatic Transmission Fluid)

Setting the carburetors

The best setting of the carburetors is obtained by using a CO-meter.

However, setting can be checked without the use of this meter, but if the checking with or without a meter results in unsatisfactory running of the engine and it has been established that the fault is due to an "over-rich" carburettor or "too lean fuel-air mixture", the carburettor nozzle should be adjusted with a special tool, see page 23:11.

Setting without CO-meter

1. Remove the floor cover on the platform and the inspection cover on the front engine casing.
 1. Check that there is oil in the damper cylinders. See under "Periodical Check".
 3. Run the engine warm. The adjustment should be carried out within about 10 minutes after the coolant thermostat has opened. (One way of finding this out is by feeling the upper radiator hose at the radiator which should suddenly become hot, approx. 80°C = 176°F.)
 4. Adjust the engine speed to 13.3 r/s (800 r/m) with the throttle stop screws (2, Figs. 23-1 and 23-3).

NOTE! Screw equally for both carburetors. Check to make sure that both carburetors have the same air valve lift. This is easily checked by simply making sure that the distance visually between the bridge of the carburettor housing and the air valve is the same for both carburetors. A more accurate synchronization is not required.
 5. Adjust with the idle trimming screws (5, Fig. 23-2, and 4, Fig. 23-4) from the basic setting (they are screwed to bottom). Adjust with the screws until the best idling speed is obtained. Screw equally for both carburetors.
 6. Adjust the link rods between the carburetors and throttle control shaft. With the control against its stop on the manifold bracket, adjust the link rods to obtain a clearance of approx. 0.1 mm (0.0039") between lever and throttle shaft flange, see Fig. 23-19.

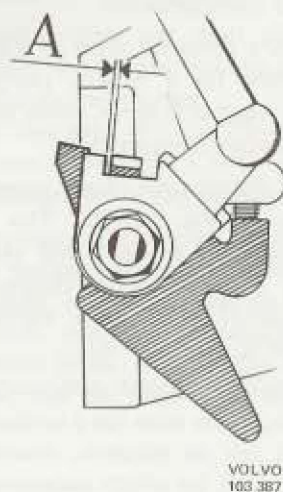

Fig. 23-19. Adjusting the control

A = 0.1 mm (0.0039")

7. Adjust so that the valve control of the hot start valve is against the carburettor lever with the valve piston in the upper position and the throttle control at idle. Lubricate the contact surfaces with Molykote. Rev up the engine, release the control and check that the engine returns to idling speed. Repeat this a couple of times.
8. Setting the fast idle: Pull out the choke 20 mm (0.8"). The mark on the cam disc should now be opposite the idle trimming screw. Then adjust the fast idle screw to give an engine speed of 23.3–25.0 r/s (1400–1500 r/m).
9. Check and if necessary adjust the throttle control to remove play. When accelerator is fully depressed, there should be a play of 1 mm (0.0039") at full throttle. See also point 6.
10. Lubricate all ball joints.
11. Re-fit the floor cover in the platform and the inspection cover.

Setting with CO-meter

The setting should be made at a temperature of +15°C to 25°C (60–80°F) and must be made within 8 minutes after the coolant thermostat has opened. Warming-up should be done with a completely cold engine.

When measuring with a CO-meter, it is important that the temperature of the carburettors is correct. When the engine is idling, the floatchamber is exposed to heat radiation from the exhaust manifold while the flow of cold fuel through the floatchamber is little.

This results in a rise in temperature causing an increase in the fuel flow through the jet due to the alteration in the viscosity and the increase in the CO-value. Revving the engine cools the carburettor to a certain extent due to the step up in the fuel flow. The temperature can be checked to make sure that it is not excessive by feeling the floatchamber with the hand. It should feel "cold", that is it more or less should not exceed room temperature.

Before reading off the CO-meter, briefly rev up the engine so that the air valve is in the proper position. To be certain that the measured CO-value is correct, measuring should be carried out within the time period mentioned above.

There is a number of different types of CO-meters available which function with acceptable accuracy. Instructions on their use are supplied with each meter. Note that when connecting the hose for evacuating the exhaust gases, the hose must not be placed so that the exhaust gases are completely evacuated from the CO-meter connection in the exhaust manifold. A funnel could suitably be used here. With it the suction at the connection would not be so great as to upset the measuring but sufficient to suck up the exhaust gases so that they do not fill the workshop.

When doing any measuring with the CO-meter, it is important that the exhaust pipe and silencer are in good condition, that is, they do not leak. Measure as follows:

1. Remove the floor cover on the platform and the inspection cover on the front engine casing.
2. Check that there is oil in the damper cylinders. They should be filled to about 6 mm (1/4") from the upper edge with Automatic Transmission Fluid. **NOTE!** The damper cylinders must not be filled with engine oil.
3. Connect a tachometer and run the engine warm at 25 r/s (1500 r/m) until the coolant thermostat opens. (One way of finding this out is by feeling the upper radiator hose at the radiator which should start to get hot.)
4. Adjust the engine speed to 13.3 r/s (800 r/m) with the throttle stop screws (2, Figs. 23-1 and 23-3).

NOTE! Screw equally for both carburettors. Check that both carburettors have the same air valve lift. This is easily checked by measuring with the eye the distance between the carburettor housing bridge and the air valve. The distance should be the same for both carburettors. More accurate synchronization is not required.

5. Connect a CO-meter and check the CO-content which should be 2.5%. **NOTE!** Before each reading, rev up the engine briefly. With the help of the idle trimming screws (5, Fig. 23-5) the CO-content can be adjusted with small deviations. (If the CO-content is too high, first check the temperature compensator, see under "Temperature Compensator" on page 23:15.
6. Adjust the link rods between the carburettors and the throttle control shaft. With the control against its stop on the manifold bracket, the link rods should be adjusted so that there is a clearance of about 0.1 mm (0.0039") between the lever and the flange of the throttle spindle. See Fig. 23-19.
7. Adjust so that the valve control of the hot-start bar is against the carburettor lever with the valve piston in the upper position and the throttle control at idle. Lubricate the contact surface with Molykote. Rev up the engine. Release the control and check that the engine returns to idling speed. Repeat this a couple of times.
8. Setting the fast idle: Pull out the choke 20 mm (0.8"). The mark on the cam disc should now be opposite the idle trimming screw. Then adjust the fast idle screw to give an engine speed of 23.3-25.0 r/s (1400-1500 r/m).
9. Check and if necessary adjust the throttle control to remove play. When accelerator pedal is fully depressed, there should be a play of 1 mm (0.0039") at full throttle. See also point 6.
10. Lubricate all ball joints.
11. Install the floor cover in the platform and the inspection cover.

Faulty carburettor function

1. Check to make sure that the reason for the fault in the function is not due to wrong damper oil or oil level, impurities in the floatchamber or a faulty float valve and float. See the respective headings.
2. Remove the air cleaner insert and check that the air valves operate easily without jamming. (The damper plungers removed.) If this is not the case, remove the suction chamber covers and clean the valves. At the same time check to make sure the diaphragm is in good condition.
NOTE! If the metering needle must be released or removed, it should be adjusted, see under "Replacing the metering needle". **A CO-meter is recommended for this purpose.**

Temperature compensator

3. If there is a powerful drop in the idling speed during idling for a lengthy period, especially when the weather is warm, check the function of the temperature compensator.

Checking: Remove the plastic cover and push in the valve (3, Fig. 23-20). This should move under very light pressure and return without jamming. This applies at temperatures above +26°C (80°F). The valve starts opening at +20°C-25°C (70°-77°F).

Pressing the valve inwards deteriorates the quality of the idle. If the valve has a tendency to be stiff or jam, it can be adjusted, providing it is not scored or lined, on which occasions it should be replaced complete. See under "Replacing the temperature compensator" on page 23:15.

Adjusting: Slacken one of the cross-slotted screws (8, Fig. 23-20) for the bi-metal spring and centre the valve. The valve should move under very little pressure and return without jamming. This applies at temperatures above +26°C (80°F). Then remove the temperature compensator from the carburettor and store it at a temperature of +20°C-25°C (70°-77°F) until it reaches this temperature. The valve should just start to open at this temperature. In other words, the valve should be loose in its seat at this temperature. If necessary adjust with the nut (9, Fig. 23-20).

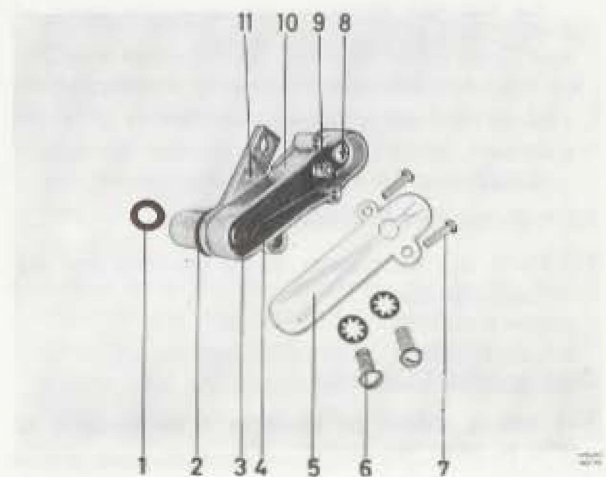

Fig. 23-20. Temperature compensator

- | | |
|--------------------|---------------------------------------|
| 1. Rubber seal | 6. Screws for temperature compensator |
| 2. Rubber seal | 7. Cover screw |
| 3. Valve | 8. Cross-slotted screw |
| 4. Bi-metal spring | 9. Adjuster nut |
| 5. Cover | 10. Housing |
| | 11. Marking |

Damper device

4. If the engine does not react properly during acceleration, the reason may be a faulty clearance on the damper plunger.

The axial clearance (A, Fig. 23-21), should be 1.0–1.8 mm (0.04–0.07"). With any fault in the damper plunger, change it complete.

If the damper device is to function properly, then the damper oil level must be correct. The plunger stem must be filled to about 6 mm (1/4") from the upper edge with Automatic Transmission Fluid. **NOTE!** The damper cylinders must not be filled with engine oil.



Fig. 23-21. Damper plunger clearance

A = 1.0–1.8 mm (0.04–0.07")

Adjusting the fuel jets

Special tools:

2895	Press tools, 2 (1 per carburettor)
2896	Spacer drift
2897	Press tool

1. Remove the floor cover in the platform and the inspection cover on the front engine casing.
2. Remove the upper part of the air cleaner and the cleaner insert.
3. Screw in the idle trimming screws to the bottom.
4. Remove the plugs in the floatchambers by inserting a screwdriver between the floatchamber cover and the plug and by levering out the plug. Screw tight the press tool 2895 in the floatchamber covers, Fig. 23-22.

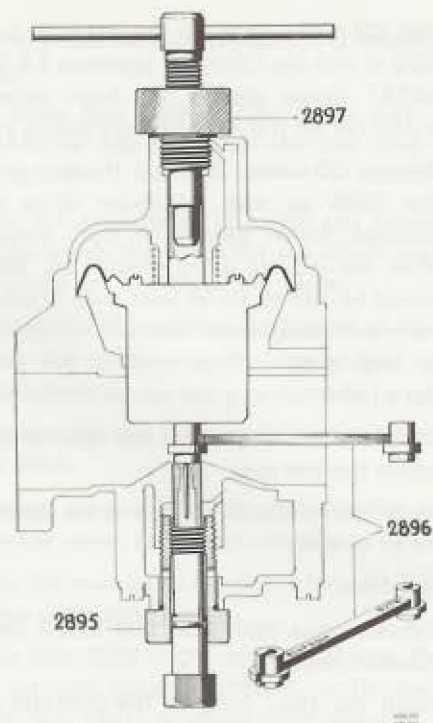

Fig. 23-22. Adjusting the fuel jet

5. Place spacer drift 2896 between the air valve and jet on one of the carburettors.
NOTE! The marking on the drift should face upwards. Use the drift marked B 20 B on the end. Check to make sure that there is a clearance between the drift shoulder and the carburettor housing bridge. If none exists, press up the the jet with press tool 2895 in order to obtain such a clearance. Then unscrew the spindle several turns so that the jet can be pressed down.
6. Remove the damper plunger and screw tight press tool 2897.
7. Press down the jet by screwing in the spindle on tool 2897 so far that the shoulder on the drift goes against the carburettor housing bridge (the carburettor is now adjusted to give "rich" fuel-air mixture).
8. Remove the upper press tool and spacer drift. Install the damper plunger.
9. Carry out points 5, 6, 7 and 8 on the other carburettor.
10. Connect a rev counter and possibly a CO-meter. Run the engine warm until the coolant thermostat opens. The adjustment (that is points 11 and 12) should be carried out within 8 minutes from the time the thermostat opens.
11. Adjust idling speed to 13.3 r/s (800 r/m). Check that the air valves have the same lift (correct with the idle trimming screws).

- 12a. **With CO-meter.** Press up the jets with press tool 2895 so that the CO-meter indicates 2.5%.
NOTE! Screw equally for both carburetors. Briefly rev up the engine before taking a reading.
- 12b. **Without CO-meter.** Press up the jets with press tool 2895 so that maximum idling speed is obtained. Screw equally on both carburetors. While the jets are being pressed up, the engine should be revved up at least once briefly. When maximum idling speed has been obtained, rev up the engine again. Then press up the jets so far that a reduction in speed can be discerned.
13. Check that the engine has the right idling speed. Adjust the link rods.
14. Install the air cleaner insert and the upper part of the air cleaner.
15. Test drive.
16. Remove press tool 2895 and install new float-chamber plugs.
17. Install the floor cover in the platform and the inspection cover.

Checking the secondary throttles

Check to make sure that the secondary throttles are centred and can be turned without jamming. Check the location ("A", Fig. 23-23) of the levers. When the secondary throttle is closed, the distance "A" between the lever pin and the intake manifold flange should be 2.7-4.3 mm (0.11-0.17").

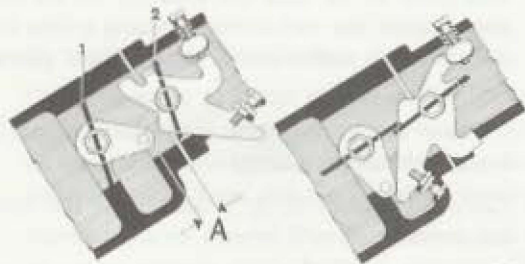

Throttle position at low output Fully open throttle

Fig. 23-23. Throttle position

1. Secondary throttle
2. Primary throttle
- A. 2.7-4.3 mm (0.11-0.17")

Removing the carburetors

1. Remove the floor cover in the platform and the inspection cover on the front engine casing.
2. Remove the hot start valve control from the rear carburettor. Remove the air cleaner.
3. Remove the ball joints of the link rods from the carburetors.
4. Remove the fuel hose, vacuum hose and choke wire from the carburetors. Remove the retaining nuts for the carburetors. Remove the carburetors and the protective plates and gaskets. Cover the holes in the intake manifold.

Replacing the diaphragm

1. Screw out the damper plunger. Make line-up marks in the suction chamber cover and carburettor housing. Remove the screws and lift off the suction chamber cover. Remove the spring.
2. Pull up the air valve with the diaphragm. Remove the diaphragm by releasing the four screws. Clean the air valve.
NOTE! Take care not to bend or displace the needle.
3. Install the new diaphragm, Fig. 23-24. The rubber register should fit into the valve groove.



Fig. 23-24. Diaphragm in air valve

4. Move the air valve down and fit in the rubber register, Fig. 23-25. Install the spring and cover. Fill with damper oil (Automatic Transmission Fluid). **NOTE!** The damper cylinders must not be filled with engine oil.
5. Install the suction chamber cover and the damper plunger.



Fig. 23-25. Diaphragm in carburettor housing

Replacing the fuel jet

Special tools:

2895	Press tool
2896	Spacer drift
2897	Press tool
2962	Drift

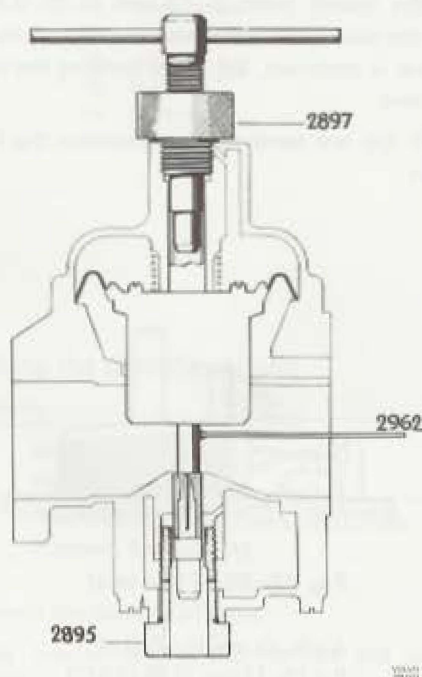

Fig. 23-26. Replacing the fuel jet

1. Remove the damper plunger and floatchamber plug.
 2. Fit press tool 2895 in the lower part of the carburettor and screw out the tool centre bolt, Fig. 23-26.
 3. Place the carburettor in a vice and tension the shanks across the flange for the intake manifold. Take care not to damage the flange.
 4. Place drift 2962 between the jet and air valve. Fit press tool 2897 on the upper part of the carburettor.
 5. Press the jet out through the centre hole in the tool 2895.
 6. Remove press tool 2897. Remove the suction chamber cover, spring and air valve.
 7. Place the new jet in the centre hole on 2895 and fit the tool's centre bolt.
 8. Place drift 2896 in the recess for the jet. Press up the jet with press tool 2895, so far that drift 2896 just starts to move itself upwards. Screw out the tool centre bolt a couple of turns.
 9. Replace the metering needle. See under "Replacing the metering needle", below.
 10. Install the air valve, spring and cover. Fill with damper oil (Automatic Transmission Fluid) and fit the damper plunger.
- NOTE!** The damper cylinders must not be filled with engine oil.
11. Install the carburettor on the engine and adjust the fuel jet according to the instructions given under "Adjusting the fuel jet", points 10-16, page 23:11.

Replacing the metering needle

After replacing the metering needle, the following check with a CO-meter is recommended.

1. Remove the vacuum chamber cover. Take out the air valve and clean it.
2. Remove the needle by unscrewing the lock screw and pull the needle out together with the spring suspension.
3. Before installing the new needle, check that the needle designation is B 2 BA. This is punched on the needle and can be seen by pulling the needle out of the spring suspension far enough to reveal it.

4. Install the needle together with the spring suspension so that the flat surface faces the lock screw. The needle should incline from the holes in the air valve, that is, in towards the air cleaner flange.

The needle should be inserted so far that the plastic washer lies flush with the valve, see Fig. 23-27.

Tighten up the lock screw.

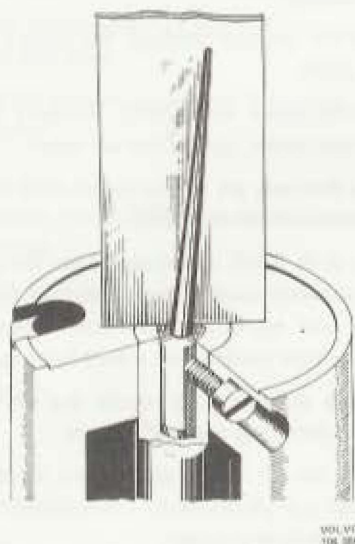

Fig. 23-27. Installing the metering needle

5. Install the air valve in the carburettor.
NOTE! Fit the diaphragm according to Fig. 23-25.
6. Install the vacuum chamber cover.

Cleaning the floatchamber

1. Remove the screws (1, Fig. 23-28).
2. Remove the floatchamber.
3. Clean the surface of the gasket using compressed air.
4. Install the floatchamber with new gasket.
NOTE! If the floatchamber plug is removed, a new plug must be fitted in order to ensure that it is properly fixed in the floatchamber.

The plug is removed by bending it out with a suitable tool between the floatchamber cover and plug.

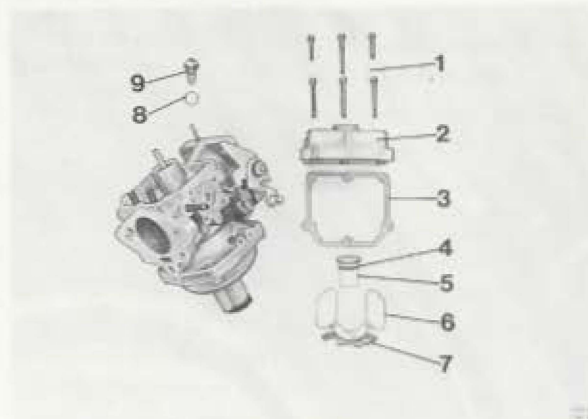

Fig. 23-28. Floatchamber dismantled

- | | |
|----------------------------|-----------------|
| 1. Screws for floatchamber | 7. Float pin |
| 2. Floatchamber | 8. Washer |
| 3. Gasket | 9. Needle valve |
| 4. O-ring | |
| 5. Plug | |
| 6. Float | |

Float level

Before checking the float level, remove the carburettor, invert it and take out the floatchamber.

The float is removed by carefully breaking the float spindle from the bridge. It is fitted with the sloping side facing away from the carburettor housing.

At the correct float level, the top point on the float should lie 15-17 mm (0.59-0.67") (B, Fig. 23-29) with the lowest point 9-13 mm (0.35-0.51") (A) above the sealing surface of the carburettor housing. If the level is incorrect, adjust by bending the tag at the float valve.

NOTE! Do not bend the arm between the float and the pin.

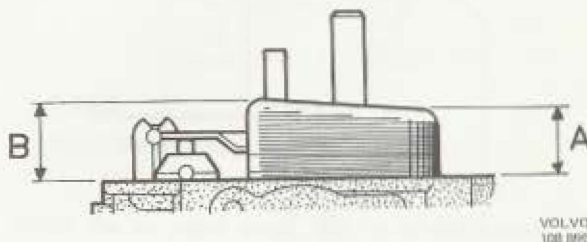

Fig. 23-29. Float level

- A = 9-13 mm (0.36-0.51")
B = 15-17 mm (0.59-0.67")

Replacing the temperature compensator

The temperature compensator is replaced complete. It is removed from the carburettor by unscrewing the screws (6, Fig. 23-30). Take out the old seal (1) from the carburettor and fit a new one. Place a new seal (2) on the temperature compensator and fit the compensator. The temperature compensator is marked "60" (11).

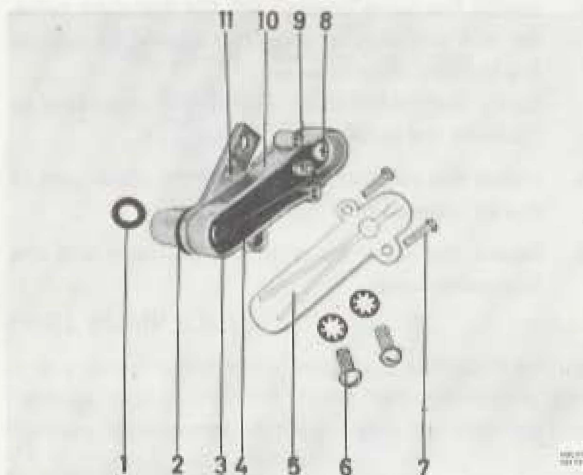

Fig. 23-30. Temperature compensator

1. Rubber seal
2. Rubber seal
3. Valve
4. Bi-metal spring
5. Cover
6. Screws for temperature compensator
7. Cover screw
8. Cross-slotted screw
9. Adjuster nut
10. Housing
11. Marking

Re-bushing the throttle spindle

Special tools:

2402	Drift
2879	Fixture
2880	Reamer, for seat
2881	Reamer, for bushing

1. Remove the damper plunger.
2. Make line-up marks and remove the vacuum chamber cover. Lift out the spring together with the air valve.
3. Remove the floatchamber and float.

4. Remove the levers and the return spring from the throttle spindle.
5. Remove the throttle. Knock out the sealing washer together with the old throttle spindle (only front carburettor). Remove the throttle spindle.
6. Remove the spindle seal (seals). Remove the nipple for the upper vacuum outlet (only front carburettor).
7. Fix the fixture in a vice and fit the carburettor on the fixture, Fig. 23-31. Make sure that the fixture pin holes are in line with the holes in the spindle bushings.



Fig. 21-31. Mounting carburettor on fixture 2879

8. Ream off the old bushings with reamer 2880. **NOTE!** Do not pull the reamer back through the bushings but move it in the working direction through the hole in the bottom plate of the fixture.
9. Turn the fixture pin 90° so that it forms a stop internally inside the carburettor housing for the bushings and drive in the bushings with drift 2402.
10. Turn the fixture pin a further 90° so that the holes in the pin come in line with the holes in the bushings. Ream the bushings with reamer 2881. **NOTE!** Do not pull the reamer back through the bushings but move it in the working direction through the hole in the bottom plate of the fixture.
11. Remove the carburettor from the fixture. Blow the carburettor clean.
12. Install the seal (seals) and if necessary a sealing washer.

13. Install the throttle and throttle spindle. Centre the throttle and rivet the retaining bolts, Fig. 23-32.

NOTE! The "bosses" on the throttle should face the floatchamber and the manifold flange.

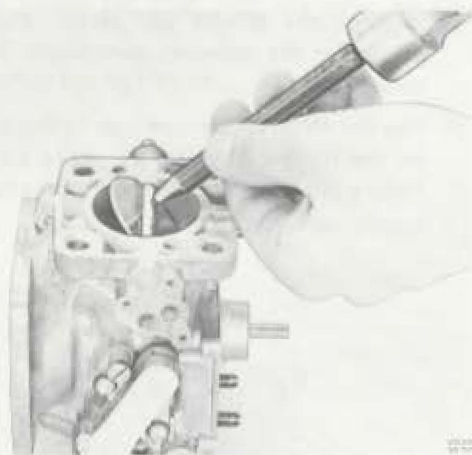

Fig. 23-32. Riveting throttle flap retaining screws

14. Install the return spring and the levers.
15. Install the float and floatchamber.
16. Install the air valve, spring and vacuum chamber.
17. Install the nipple for the upper vacuum output (only front carburettor).

Installing the carburettors

1. Clean the gasket surface. Install the protecting plates, new gaskets, one on each side of the plates, and the carburettors, Fig. 23-33.

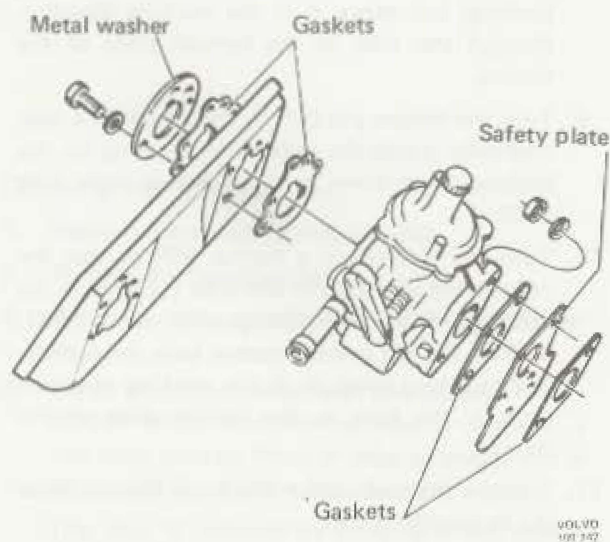

Fig. 23-33. Installing the carburettor

2. Connect the ball joints, fuel hoses, vacuum hose and choke wire. Make sure that the choke control on the instrument panel is pushed in. Then lock tight the pull wire on the rapid idle cam clamping screw. Thereafter fix the pull wire outer sleeve with the clips intended for this purpose.
3. Install the lower part of the air cleaner and the hose for the crankcase ventilation.
4. Install the valve control for the hot-start valve. At idle position, the control should be against the throttle control lever. Carry out carburettor adjustment according to "Setting the carburettors", page 23:8.
5. Install the air cleaner insert and the upper part of the air cleaner.
6. Install the floor cover in the platform and the inspection cover.

Replacing the air cleaner insert

No cleaning etc, need be done between insert changes. Under no circumstances may the insert be moistened or oiled.

A sign of a blocked air cleaner is increased fuel consumption.

FUEL PUMP

Pierburg

If the pump is defective, replace it complete. A filter insert for cleaning is available in stock.

Cleaning (pump removed)

1. Remove the cover retaining screw (1, Fig. 23-34). Lift off the cover (6), the filter (3) and the seal (2).
2. Clean the pump body and cover. Blow clean or replace the filter.
3. Place the gasket and filter in position on the pump body.
4. Install the cover. Make sure that the profiles in the pump body and cover coincide.



Fig. 23-34. Pierburg fuel pump

1. Profile (suits profile 5 in cover 6)
2. Seal
3. Filter
4. Cover screw
5. Profile (suits profile 1)
6. Cover

FUEL PUMP S.E.V.

If this pump is defective, replace it complete with a Pierburg type pump. AB Volvo Parts stock only the Pierburg type pump. A filter insert for cleaning the S.E.V. pump is available in stock.

Cleaning (pump removed)

1. Remove the cover (1, Fig. 23-35), the spring (5) and the seal (4).
2. Clean the pump body.
3. Remove the filter (6) and blow it clean or replace it.
4. Install the filter. Place the seal with the open part over the filter. Install the spring and cover. The pin (2) in the cover should fit in the spring (5).

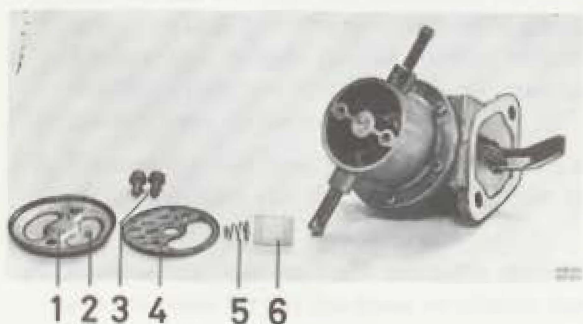

Fig. 23-35. S.E.V. fuel pump

1. Cover
2. Pin for centering spring (5)
3. Cover screws
4. Seal
5. Spring
6. Filter

FUEL TANK

Removing

1. Remove the plug underneath the tank and drain the fuel.
2. Remove the breather hose from the filler pipe.
3. Remove the electric cables from the tank level gauge unit.
4. Remove the fuel pipe from the tank.
5. Remove the tensioning band adjuster nuts.
6. Bend down the tensioning band and remove the fuel tank.

Installing

1. Lift the fuel tank into position.
2. Bend up the tensioning band and fit the retaining nuts. Note the location of the rubber strips, Fig. 23-36.

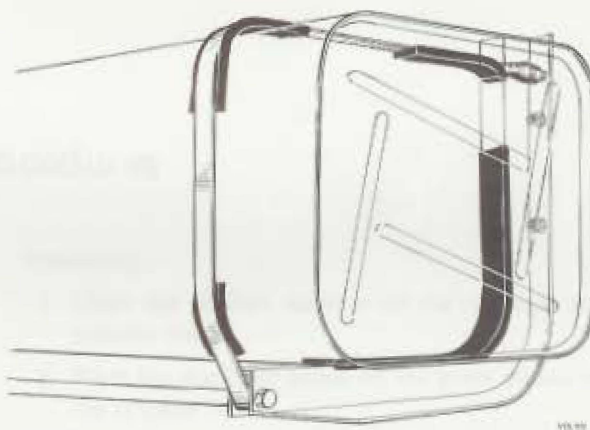

Fig. 23-36. Installing the fuel tank

3. Install the fuel pipe and drain plug.
4. Install the electric cables for the tank fuel level gauge.
5. Install the breather hose on the filler pipe.

GROUP 25 INTAKE AND EXHAUST SYSTEM

Description

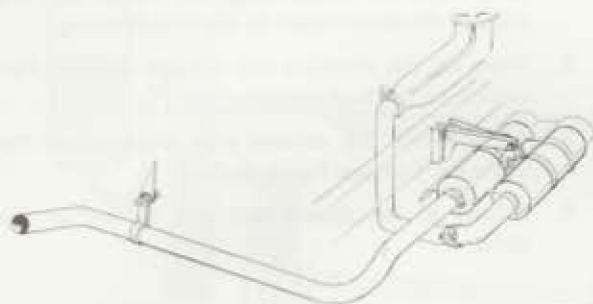

Fig. 25-1. Exhaust system

The intake and exhaust manifolds are made of nodular iron and are cast onto a branch pipe.

Each intake port houses a spring-loaded throttle (secondary throttle). The function of the secondary throttle is described on page 23:3.

Otherwise the system consists of a front exhaust pipe section, two silencers and a rear exhaust pipe section.

Service Procedures

MANIFOLD

Removing

1. Remove the inspection cover from the front engine casing and the floor cover in the platform.
2. Release the clasps and remove the upper part of the air cleaner housing.
3. Remove the choke wire from the rear carburettor.
4. Remove the lock clips and disconnect the carburettor link rods from the throttle control spindle. Remove the throttle control spindle lock clip and disconnect the spindle from the manifold bracket. Hang up the spindle.
5. Remove the fuel hose from the branch pipe on the carburettors and the vacuum hose from the front carburettor.
6. Remove the vacuum hoses from the manifold and the hoses for the crankcase ventilation from the manifold and air cleaner.
7. Remove the front exhaust pipe section from the manifold and from the attachment to the clutch casing.
8. Remove the manifold retaining nuts.
9. Lift forward the manifold.
10. Remove the manifold gasket.

Installing

1. Clean the contact surfaces on the manifold and cylinder head.
2. Place the manifold gasket on the guide sleeves on the cylinder head.
3. Position the manifold and install the washers and retaining nuts.
4. Install the front exhaust pipe section and clamp the pipe securely to the attachment on the clutch casing.
5. Fit and connect the vacuum hoses to the manifold and the hoses for the crankcase ventilation to the manifold and air cleaner.
6. Install and fit the vacuum hose to the front carburettor and the fuel hose to the branch pipe on the carburettors.
7. Press firmly the throttle control spindle on to the branch bracket and fit the lock clip. Press the link rods firmly on to the throttle spindle for the carburettors and fit the lock clips.
8. Install the choke wire onto the rear carburettor.
9. Install the upper part of the air cleaner housing.
10. Install the floor cover in the platform and the inspection cover on the front engine casing.

EXHAUST SYSTEM

Removing

1. Remove the nuts on the manifold flange. Remove the front exhaust pipe section from the gearbox attachment.
2. Remove the silencers from the body attachment. Take down the exhaust system.

Installing

1. Install a new flange gasket and lift the front exhaust pipe section up into position. Fit the nuts on the manifold flange and clamp tight the pipe to the attachment on the clutch casing.
2. Hang up the silencers and the rear exhaust pipe section to the body attachment.
3. Fit together the exhaust pipe sections and the silencers. Use new flange gaskets.
4. Adjust in the attachment and tighten up the bolts.

GROUP 26 COOLING SYSTEM

Description

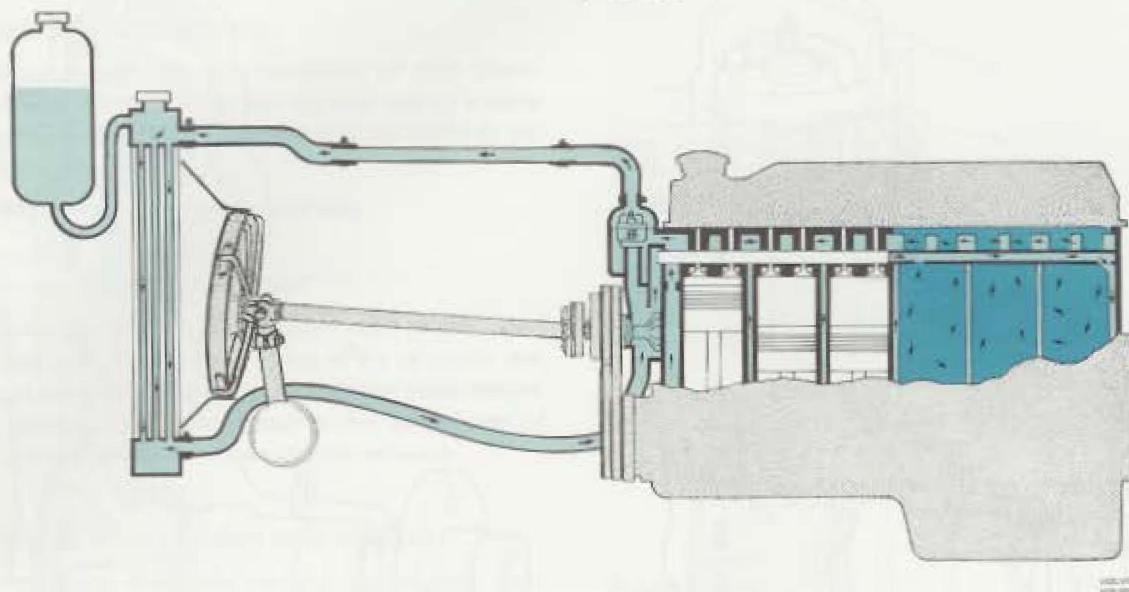

Fig. 26-1. Sealed cooling system

The engine is fluid-cooled and the cooling system is of the sealed type, see Fig. 26-1. Coolant circulation is provided by a centrifugal pump, Fig. 26-2, and a double-operating thermostat ensures rapid heating of the engine and contributes to the maintenance of the most suitable temperature for the engine under all operating conditions.

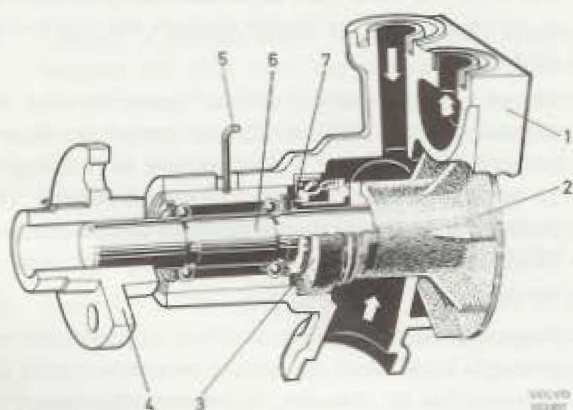

Fig. 26-2. Coolant pump

1. Housing
2. Impeller
3. Seal ring
4. Flange
5. Lock spring
6. Shaft with ball bearings (integral unit)
7. Wear ring

To achieve the desired effect with the sealed cooling system, it must be well-filled and it must not leak. As coolant, a mixture of 50% Volvo anti-freeze* and 50% water should be used all the year round. This mixture provides protection against frost down to -35°C (-32°F). The coolant should be changed every other year. On this occasion the engine, radiator and expansion tank should be flushed clean with water at the same time.

*Volvo anti-freeze (red-coloured) should not be mixed with other types of anti-freeze.

The cooling fan drive mechanism can be seen from Fig. 26-3.

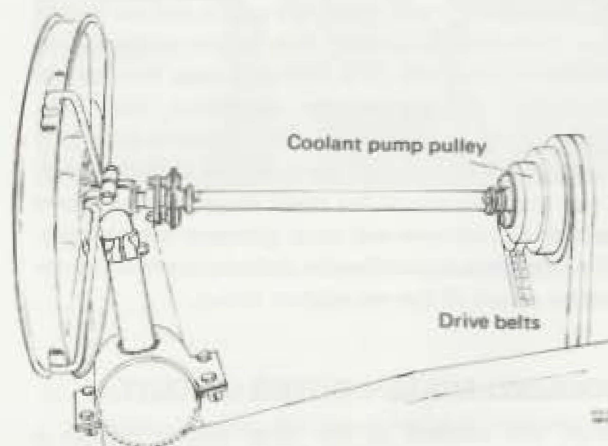

Fig. 26-3. Fan coupling

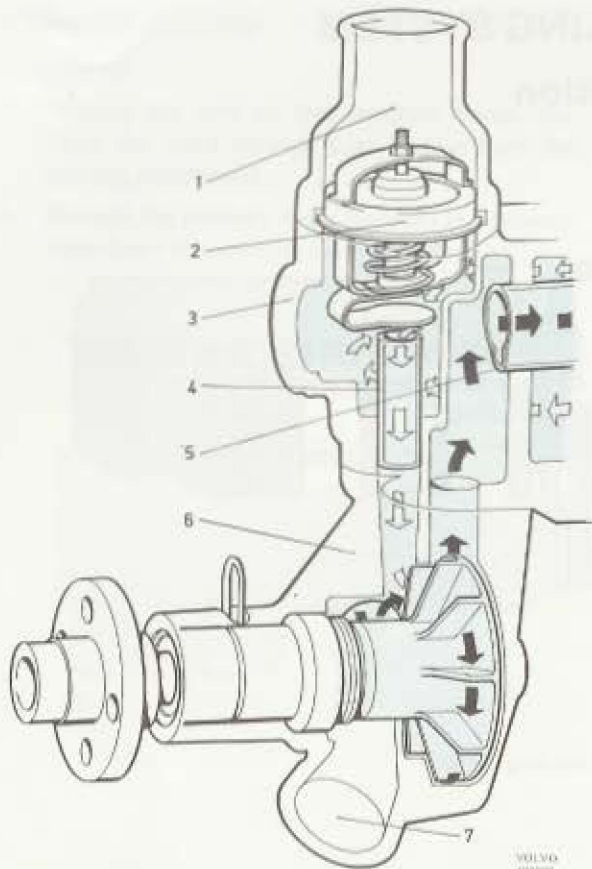

Fig. 26-4. Coolant flow, thermostat closed

- | | |
|------------------|----------------------|
| 1. To radiator | 5. Distributing pipe |
| 2. Thermostat | 5. Water pump |
| 3. Cylinder head | 7. From radiator |
| 4. By-pass pipe | |

COOLING SYSTEM INNER CIRCUIT (BY-PASS)

The cooling system consists of two circuits, an inner and an outer one.

When the engine is warming up and in very cold weather when large quantities of heat are required for heating up the inside of the car, the coolant circulates almost exclusively through the inner circuit (the by-pass). This circuit covers the engine and car heater. The thermostat is closed, that is, the outlet to the radiator is shut off. The coolant passes through the thermostat by-pass to the distributor pipe (Fig. 26-4) in the cylinder head. This results in a uniform cooling of the warmest parts in the cylinder head. Even the parts round the spark plugs are also evenly cooled and maintained at a constant temperature. The coolant surrounding the cylinder walls is circulated by means of thermo-syphon action.

COOLING SYSTEM OUTER CIRCUIT

When the coolant in the inner circuit reaches a suitable temperature for the engine, the thermostat begins to open during which time the by-pass

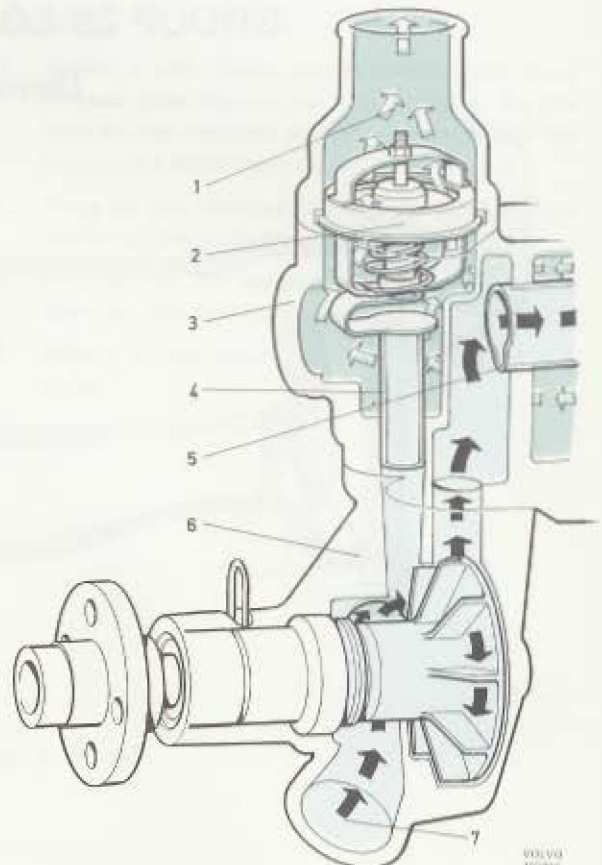
Fig. 26-5. Coolant flow, thermostat open
Concerning numbers above, see previous figure

between the thermostat housing and the pump gradually closes, see Fig. 26-5.

Coolant flows from the engine into the upper part of the radiator, is cooled and then sucked by the pump out from the lower part of the radiator from where it is conveyed into the engine through the distributing pipe.

An air cushion forms in the upper part of the expansion tank and permits the coolant to expand without involving any loss of coolant so that there is air suction at reduced temperature and volume. This arrangement ensures that the cooling system is always filled with coolant, thus minimizing the risk of corrosion.

When the cooling system is being topped-up, it will probably be difficult to prevent air from entering the system. The air, however, is subsequently separated and forced out into the expansion tank where it is replaced by coolant from this tank. It is, therefore, important to check the coolant level after the system has been emptied and filled with new coolant.

The expansion tank cap is provided with a valve, which opens when the pressure in the system goes up to 0.7 atmospheric gauge. There is also a valve which opens when there is vacuum in the system and admits air into the expansion tank.

Service Procedures

Topping-up with coolant

Topping-up with coolant, consisting of 50% Volvo anti-freeze and 50% water (all the year round) is done in the expansion tank when the level has fallen to the MIN mark.

NOTE! Never top up with water only.

Draining the cooling system

To drain the coolant, open a drain cock on the lower radiator pipe. There is also a plug in the oil cooler and one in the left-hand side of the cylinder block behind the ignition distributor as well as one on the rear of the cylinder head. These can also be removed.

Filling an empty system with coolant

Before filling, flush the cooling system with clean water. When filling with coolant, through the filler opening on top of the radiator, the heater control should be set to MAX. Fill the radiator to the top and fit the cap. Also fill the expansion tank to MAX or to max. 30 mm (1/8") above this mark. Run the engine for several minutes at different speeds. If necessary, top up with more coolant and then fit the expansion tank cap. After driving for a short time, check the coolant level and top up with more coolant since it takes some time before the system is completely devoid of air.

Cooling system leakage check

1. Connect a leakage tester to the cooling system between the hose from the expansion tank and the radiator, Fig. 26-6. Use a T-nipple and two hoses for connecting up. With this also check the valve for overpressure in the expansion tank cap. The valve should be pressed up from its seat and should open when the pressure in the cooling system exceeds 70 kPa (0.7 kp/cm² = 10 lbf/in²)
2. Carefully pump up the pressure to 70 kPa (0.7 kp/cm² = 10 lbf/in²) and note the pressure gauge test instrument. The pressure must not drop noticeably during 30 seconds. If it does, check this and remedy any leakages.
3. Remove the pressure tester for the cooling system and connect the hose from the expansion tank to the radiator.
4. Remove the expansion tank cap. Feel to see whether the valve for the vacuum, in the centre of the cap has not stuck against its seat.
5. Fit the cap.

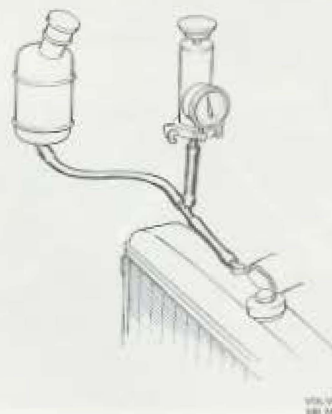

Fig. 26-6. Pressure-testing the cooling system

RADIATOR

Removing

1. Remove the lower radiator pipe clamps (2) from the side member.
2. Remove the lower radiator hose from the radiator and drain the coolant.
3. Remove the cover on the dashboard (part with ashtray) and the panel for the diff. lock controls, Fig. 26-7.



Fig. 26-7. Removing the cover over the radiator and the panel for the diff. lock controls

4. Remove the cover plate over the radiator (4 bolts). Remove the upper radiator hose and the hose running from the expansion tank to the radiator.

- Remove the retaining bolts on the side of the radiator (1 per side), Fig. 26-8.



Fig. 26-8. Retaining bolt on side of radiator

- Remove the bumper centre stay and the clamp for the clutch wire, Fig. 26-9.
- Remove the member under the radiator, Fig. 26-9. Move the wires to the one side and take down the radiator.

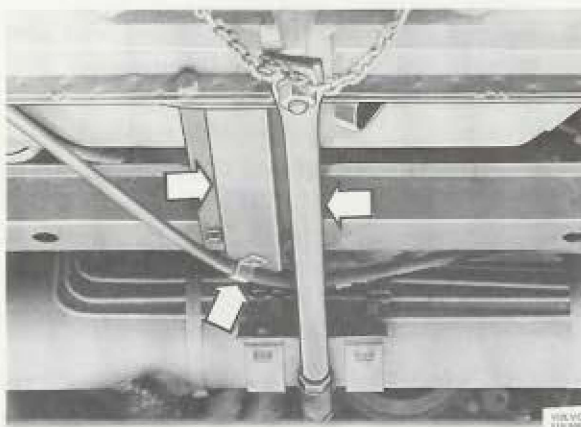

Fig. 26-9. Removing parts under the radiator

Installing

- Lift up and fit in the radiator.
- Install the member under the radiator.
- Install the lower radiator hose and clamp tight the radiator pipe to the side member (2 clamps).
- Install the bumper centre stay and clamp tight the clutch wire.
- Install the retaining bolts on the side of the radiator.

- Install the upper radiator hose and the hose running from the expansion tank to the radiator.
- Fit the panel for the diff. lock controls.
- Fill with coolant through the opening on the radiator, the heater-control on the panel should be at MAX. Also fill the expansion tank to the MAX mark.
- Install the cover plate over the radiator and the cover over the dashboard.

Replacing the coolant pump

- Drain the coolant by opening the drain cock on the lower radiator pipe.
- Slacken the drive belts.
- Remove the fan shaft retaining nuts at the flanges on the coolant pump pulley and at the fan bearing bracket.
- Release the clamping screw securing the fan bearing to the bearing bracket. Move the fan bearing forwards and remove the fan shaft.
- Remove the coolant pump pulley.
- Remove the retaining bolts for the coolant pipes and pull the pipes out of the coolant pump.
- Screw loose and remove the coolant pump. The fan shaft is carefully moved to the one side.
- Clean the cylinder block of old gasket residues.
- Install the sealing rings on top of the pump and the rings on the pipes.
- Provide the pump with a new gasket, "pump - cylinder block".
- Install the pump in position with the upper coolant pipe pushed into the pump. Press the pump upwards against the cylinder head extension under the bolting so as to obtain complete sealing between pump and cylinder head.
- Install the lower coolant pipe. Push the coolant pipes well into position before tightening up their retaining bolts.
- Close the drain cock on the lower radiator pipe.
- Install the pulley and drive belts, and adjust the belt tension.
- Install the fan shaft and tighten up the fan bearing clamping screw.
- Fill the system with coolant through the opening on the radiator, with the heater control at MAX. Also fill the expansion tank to the MAX mark. Test-run the engine and check for leakage.

Testing the thermostat

After being removed, the thermostat can be tested in a vessel containing heated water, Fig. 26-10. The thermostat, which is marked 82°, should start opening at 79-83°C (175-182°F) and should be fully open at 95°C (203°F).

If necessary replace the thermostat. Use a new gasket when installing the thermostat.

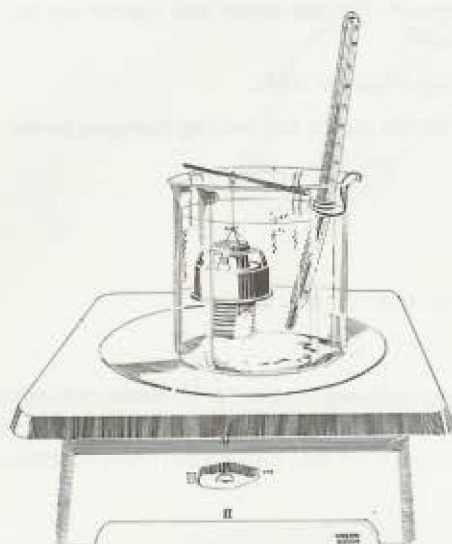

Fig. 26-10. Testing the thermostat

Replacing the drive belts

1. Slacken the drive belts.
2. Remove the fan shaft retaining nuts at the flanges on the coolant pump pulley and at the fan bearing bracket.
3. Release the clamping screw securing the fan bearing to the bearing bracket. Move the fan bearing forwards and remove the fan shaft.
4. Carefully move the fan shaft to the one side. Remove the drive belts and fit new ones (HC 38x888).
5. Install the fan shaft and tighten up the fan bearing clamping screw.
6. Tension the drive belts. If the belts are properly tensioned it should be possible to depress them 5-10 mm (3/8") halfway with the thumb between the alternator and coolant pump pulleys.

NOTE! The alternator must be obliquely loaded. If a levering bar is used for the adjustment, this should be applied between the engine and the front of the alternator.

NOTE! If the lower alternator bolt is not slackened for this adjustment, there will be a great deal of stress on the drive bearing shield.

FAN DRIVE ASSEMBLY

Removing fan and bearing bracket

1. Remove the fan shaft retaining nuts for the flanges on the coolant pump pulley and at the fan bearing bracket.
2. Release the clamping screw securing the fan bearing to the bearing bracket. Move the fan bearing forwards and remove the fan shaft.
3. Remove the screw for the clamp round the fan shroud. Release the air bellows from the fan shroud and remove it forwards.
4. Remove the band clamps securing the brake pipes to the front tubular member.
5. Mark up the location of the bearing bracket, see Fig. 26-11. **Note!** This must be done to ensure that the bearing bracket is re-installed in the correct position.

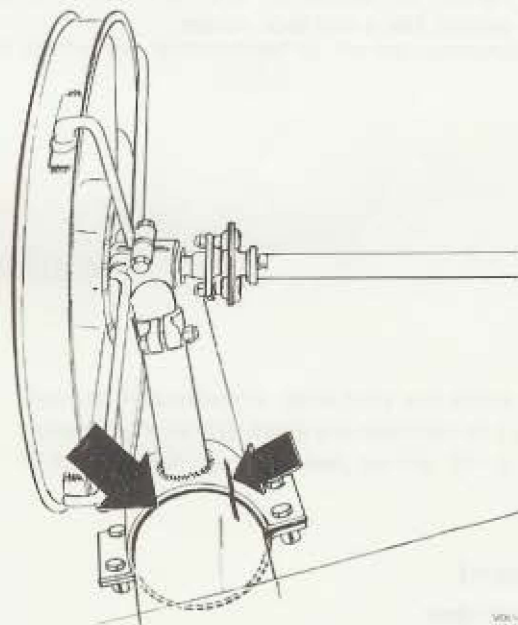

Fig. 26-11. Marking of fan bearing bracket

6. Remove the bearing bracket cap and take down the bearing bracket and fan.

Replacing cooling fan (Removed from vehicle)

1. Bend up the lock washer and remove the fan's retaining screws.
2. Remove the fan.
3. Install the fan, washer and lock washer. Fit and tighten up the screws. Lock with the lock washer. Use a new lock washer.

Replacing fan journalling (Removed from vehicle)

1. Bend up the lock washer and remove the fan's retaining screws. Remove the fan.
2. Pull off the rear flange (against the fan shaft) with a standard puller.
3. Pull the fan journalling out of the bearing bracket.
4. Press the fan hub off the fan journalling.
5. Press the fan hub onto the new fan journalling. There should be a gap of about 3 mm (1/8") between hub and bearing.
6. Install the fan journalling in the bearing bracket.
7. Press the flange onto the fan journalling. The flange should be flush with the end of the bearing shaft.
8. Install the fan, washer and lock washer. Fit and tighten up the screws and lock with the lock washer. Use a new lock washer.

Installing fan and bearing bracket

1. Place the bearing bracket and fan on the tubular member.
2. Fit the cap and tighten up the front screws. Adjust the bearing bracket according to the line-up marks and tighten up the rear screws.
3. Install the band clamps round the brake pipes.
4. Fit the air bellows and clamp round the fan shroud. Fit the screw and tighten up the clamp ring.
5. Install the fan shaft.
6. Tighten up the fan bearing clamping screw.

GROUP 27 THROTTLE CONTROLS

Description

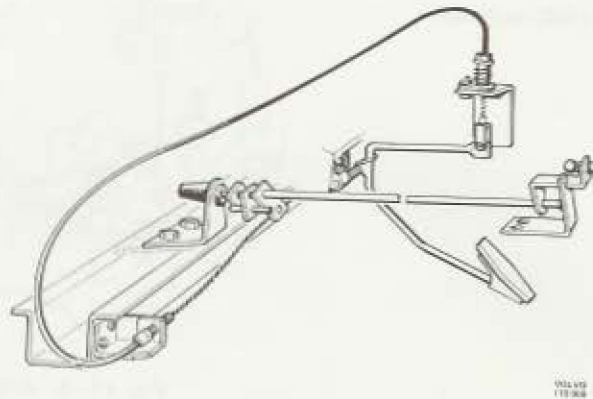

Fig. 27-1. Throttle controls

The accelerator pedal is of the suspended type. It operates the throttle shaft via a wire. Movement is subsequently transferred via link rods to the carburetors.

The choke wire is connected to the rear carburettor.

Service Procedures

Adjusting throttle controls

1. Adjust the link rods between the throttle control shaft and carburetors, with engine idling. There should be a clearance of approx. 0.1 mm (0.0039'') between the lever and throttle shaft flange, see Fig. 27-2.
2. Depress the accelerator pedal fully and adjust the throttle wire so that there is a clearance of 1 mm (0.039'') at full throttle travel, see Fig. 27-3.



VOLVO
103 387

Fig. 27-2. Adjusting throttle control, idle position
A = 0.1 mm (0.0039'')

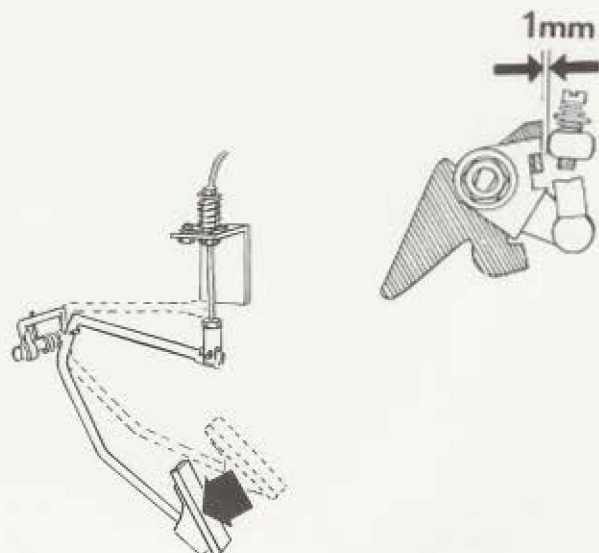

VOLVO
103 755

Fig. 27-3. Adjusting throttle wire

Replacing fan journalling (Removed from vehicle)

1. Bend up the lock washer and remove the fan's retaining screws. Remove the fan.
2. Pull off the rear flange (against the fan shaft) with a standard puller.
3. Pull the fan journalling out of the bearing bracket.
4. Press the fan hub off the fan journalling.
5. Press the fan hub onto the new fan journalling. There should be a gap of about 3 mm (1/8") between hub and bearing.
6. Install the fan journalling in the bearing bracket.
7. Press the flange onto the fan journalling. The flange should be flush with the end of the bearing shaft.
8. Install the fan, washer and lock washer. Fit and tighten up the screws and lock with the lock washer. Use a new lock washer.

Installing fan and bearing bracket

1. Place the bearing bracket and fan on the tubular member.
2. Fit the cap and tighten up the front screws. Adjust the bearing bracket according to the line-up marks and tighten up the rear screws.
3. Install the band clamps round the brake pipes.
4. Fit the air bellows and clamp round the fan shroud. Fit the screw and tighten up the clamp ring.
5. Install the fan shaft.
6. Tighten up the fan bearing clamping screw.

C3-series

3. Pull out the choke approx. 20 mm (3/4"). The mark on the cam disc should now be opposite the fast idle trimming screw, see Fig. 27-4. Adjust engine speed with the fast idle trimming screw to 23.3–25.0 rev/sec (1400–1500 rev/min).
4. Lubricate all stud bolts.

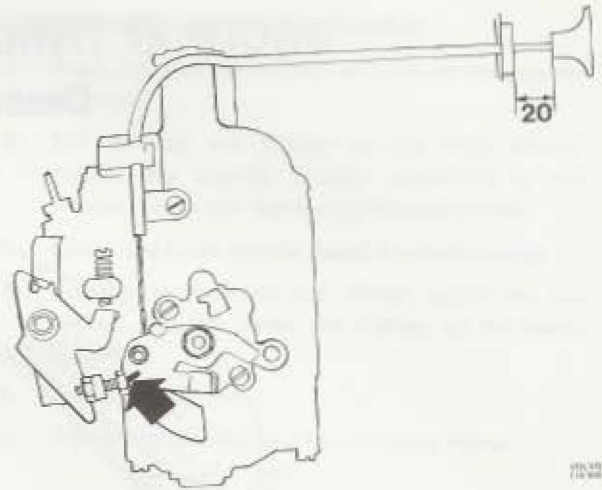
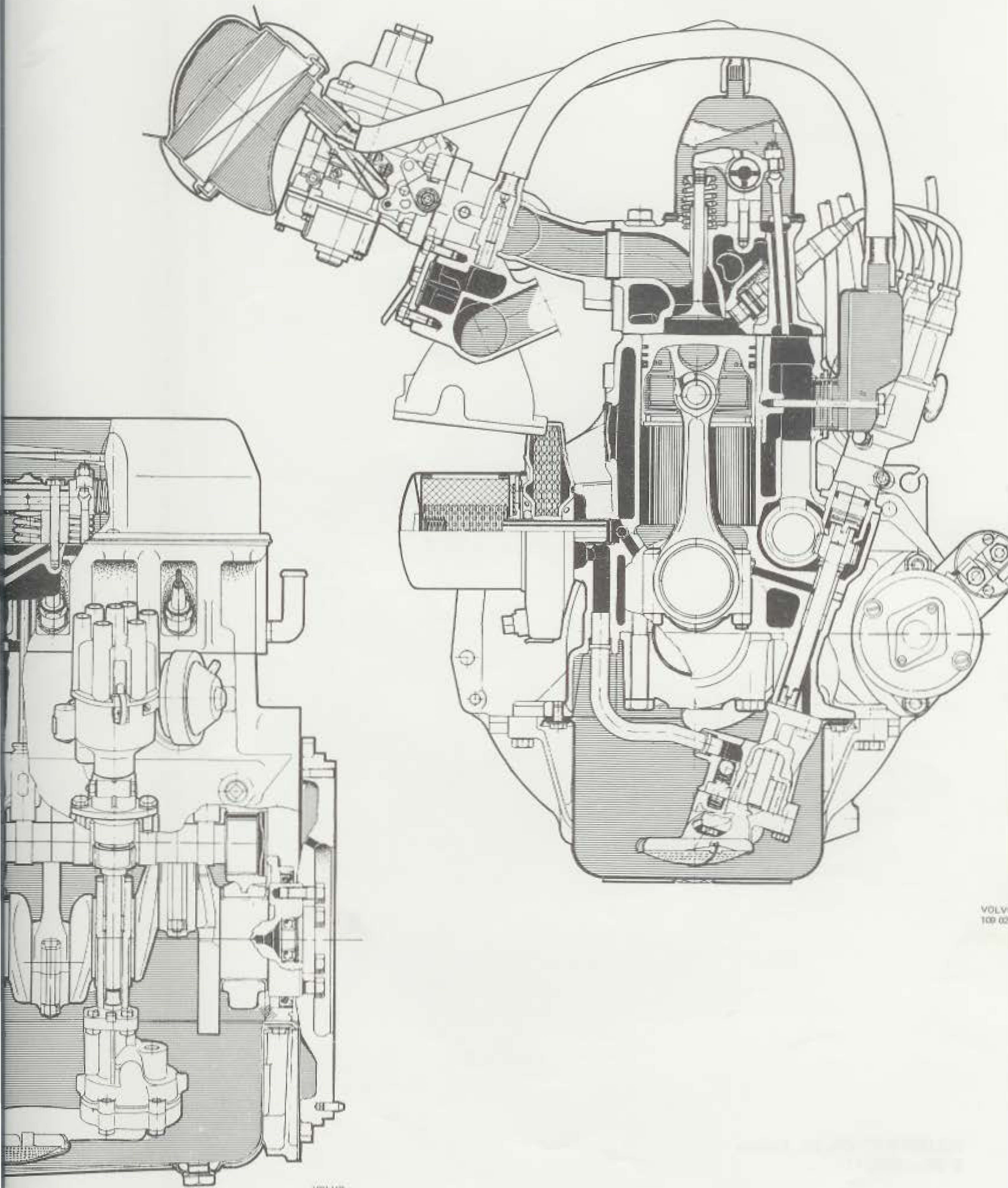
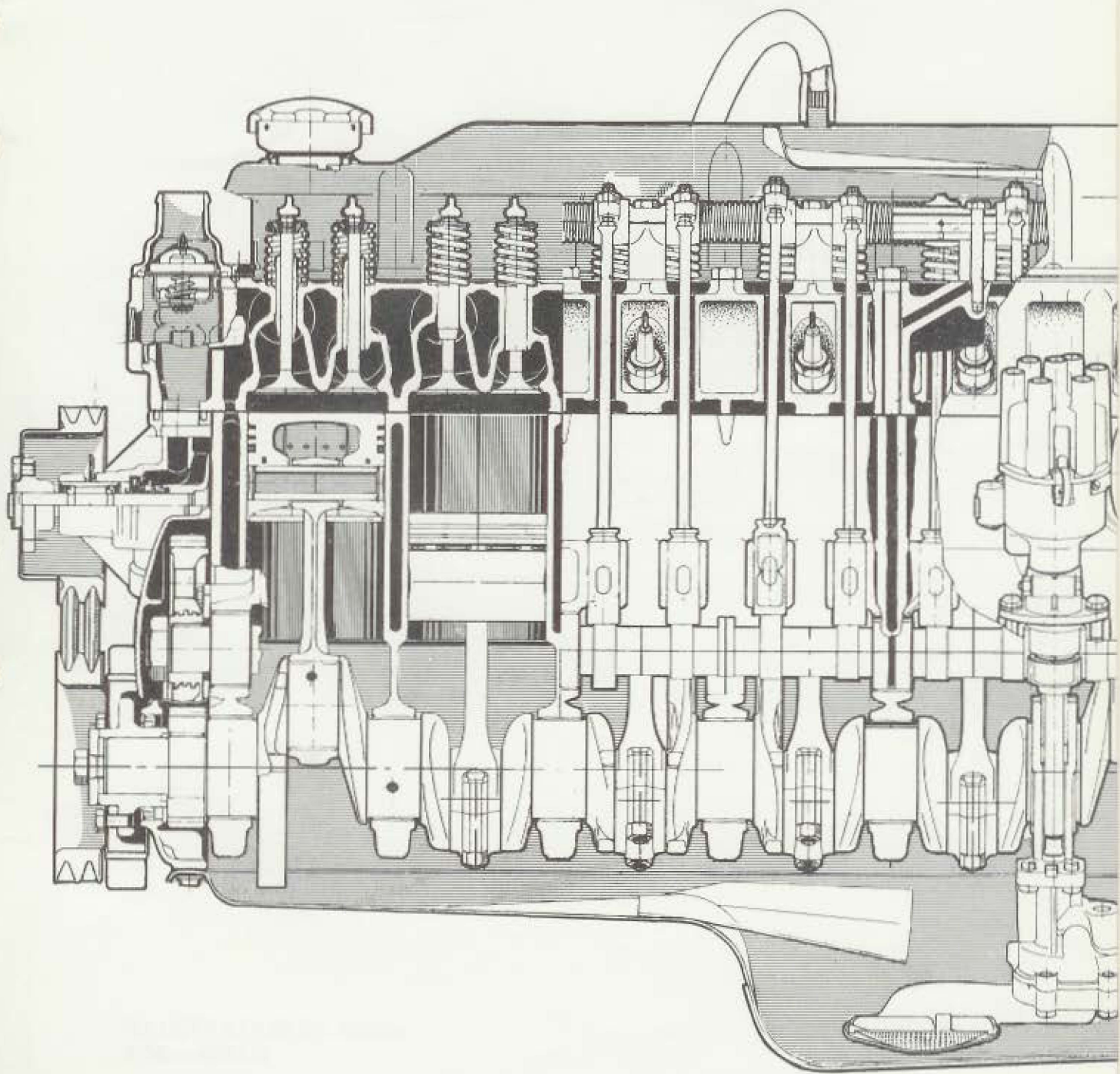

Fig. 27-4. Adjusting the choke



VOLVO
100 019

VOLVO
100 020



BRANDON O'BRIEN



PART 2

ENGINE

C3-series

SERVICE MANUAL

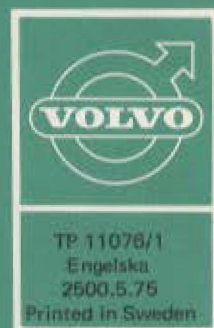

TP 11076/1
Engelska
2500.5.75

Printed in Sweden

R.1000.11.78