

PART 5

BRAKES

C3-series

SERVICE MANUAL

CONTENTS

Group 50 General

Data	1
Tools	2
Description	3
Service Procedures	3
Cleaning	3
Brake fluid	3
Testing brakes with roller tester	4
Hydraulic test with testing device	4
Fault-tracing scheme (for brake test)	6
Brake test without aids	7

Group 51 Brake shoes, drums and linings

Description	1
Service Procedures	1
Adjusting the wheel brakes	1
Servicing the front wheel brakes	2
Servicing the rear wheel brakes	3

Group 52 Hydraulic service brakes

Description	1
Master cylinder	2
Wheel cylinders	3
Warning valve	4
Brake pedal	5
Brake system warning devices	5
Service procedures	6
Master cylinder	6
Wheel cylinders	9
Brake lines	10
Brake fluid reservoirs	11
Brake pedal	11
Pedal journalling	11
Warning valve	12
Contact for stop lights	12
Contact for brake pedal travel	13
Hydraulic system (bleeding)	13

Group 54 Auxiliary brakes

Description	1
Service Procedures	4
Servo unit	4
One-way valve	5
Air cleaner	5

Group 55 Parking brake

Description	1
Service Procedures	2
Adjusting the parking brake	2
Propeller shaft brake	2
Parking brake mechanism	3
Parking brake wire	3

GROUP 50 GENERAL

Data

SERVICE BRAKES

Wheel brakes

Type	Drum brakes
Brake drum:	
Diameter, nominal	279.4 mm (11")
max.	282.4 mm (11.12")
Radial throw, max.	0.1 mm (0.004")
Brake linings:	
Type	Mintex, bonded
Effective area per front wheel	414 cm ² (64 in ²)
per rear wheel	256 cm ² (40 in ²)
total	1340 cm ² (208 in ²)

Wheel cylinder, front wheels:

Nominal diameter	28.57 mm (1.125")
Bore, max.	28.68 mm (1.129")
Piston diameter, min.	28.42 mm (1.120")
Clearance, piston — cylinder, max.	0.26 mm (0.01")

Wheel cylinder, rear wheels:

Nominal diameter	31.75 mm (1.250")	25.40 mm (1.000")
Bore, max.	31.84 mm (1.254")	25.51 mm (1.004")
Piston diameter, min.	31.58 mm (1.243")	25.25 mm (0.994")
Clearance, piston — cylinder, max.	0.26 mm (0.01")	0.26 mm (0.01")

Master cylinder

Type	Tandem cylinder
Nominal diameter	28.57 mm (1.125")
Bore, max.	28.68 mm (1.129")
Piston diameter, min.	28.42 mm (1.120")
Clearance, piston — cylinder, max.	0.26 mm (0.01")

Brake lines

Outer diameter	3/16"
----------------------	-------

Warning valve

Pressure difference for warning function	0.5—1.5 MPa (5—15 kp/cm ² = 71—213 lbf/in ²)
--	--

Servo unit

Designation	Lockheed type 7
Control piston, diameter	9.5 mm (3/8")
Min. hydraulic pressure for servo operation (cut-out point)	0.32 MPa (3.2 kp/cm ² = 45 lbf/in ²)
Reduction	approx. 1:4

PARKING BRAKE

Brake drum

Diameter, nominal	250 mm (9.84")
max.	253 mm (10.0")
Radial throw, max.	0.1 mm (0.004")
Imbalance, max.	4 mNm (40 gcm)

Brake linings:

Type	Jurid, bonded
Effective area	176 cm ² (27 in ²)

Return spring:

Outer diameter, upper spring	11.2 mm (0.44")
lower spring	8 mm (0.32")
Pulling power for 1 cm (0.39") extension,	
upper spring	180 N (18 kp = 40 lbf)
lower spring	50 N (5 kp = 11 lbf)

Tools

The special tools shown in Figs. 50-1 and 50-2 are used for repairs on the brake system.

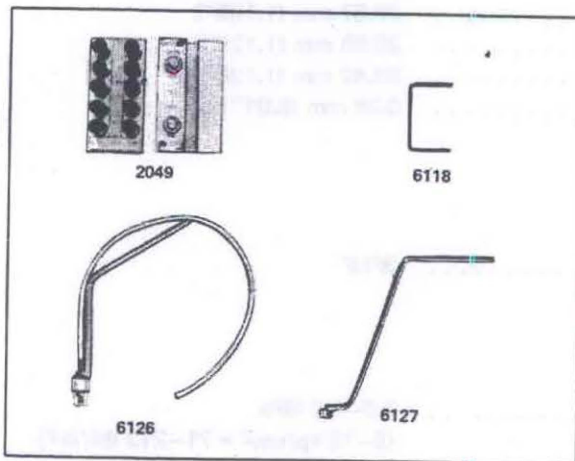


Fig. 50-1 Special tool

2049 Flanging tool

6118 Protective bracket for wheel cylinder, rear wheels

6126 Bleeder tool

6127 Spanner for adjusting rear wheel brakes

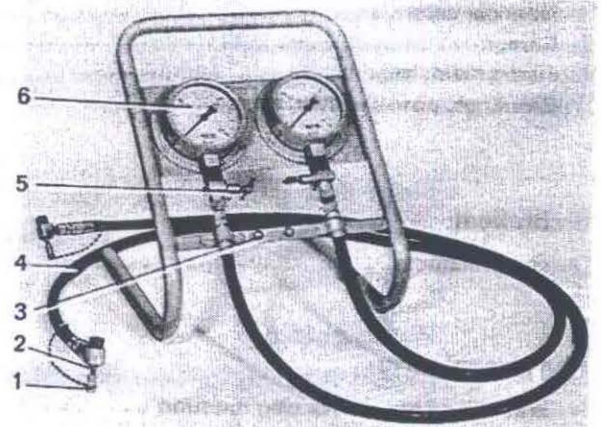


Fig. 50-2. Test device, 2741

1. Protective cap

2. Connection nipple

3. Expansion nipple

4. Hose

5. Bleeding device

6. Pressure gauge

For tightening up loose brake lines, use cap nut 945752 for the external thread and 945753 for the internal thread. In both cases the cap nuts are supplemented with rubber buffer 1210673, Fig. 50-3.

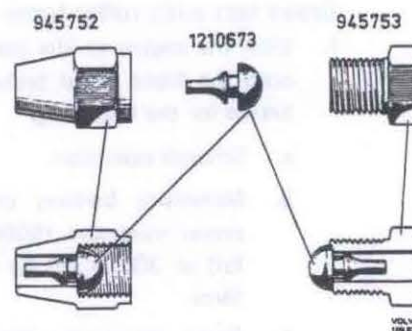


Fig. 50-3. Sealing nipples

Description

The vehicle has two brake systems independent of each other, the service brakes and parking brake.

The service brakes are vacuum-hydraulic drum brakes. The hydraulic part of these brakes as well as the control and operating devices are dealt with under

Group 52. The vacuum section is dealt with under Group 54, and the brake shoes and brake drums under Group 51.

The parking brake is mechanical and operates on the propeller shaft. It is dealt with under Group 55.

Service Procedures

Cleaning

The components of the hydraulic brake system must be cleaned in clean brake fluid or denaturalized spirit which does not contain benzene (benzole).

Petrol, white spirit, trichloroethylene or spirit with benzene must not be used for the cleaning since these as well as the slightest drop of mineral oil will attack the rubber seals and cause them to swell out. For this reason, wash your hands with soap and water before touching the internal parts of the system. The mechanic appointed to work on the hydraulic components should be provided with natural rubber gloves.

The final cleaning should be done in a cleaning agent free from impurities, after which the parts can be dried with air. Filtered compressed air free from water can be used to precipitate the drying and complete the cleaning. It is important that no spirit residues are left in the system when it is filled with brake fluid. Traces of spirit in the brake fluid lowers its boiling point and can give rise to vaporization and functional disturbance.

After cleaning and drying the components, coat them with brake paste, assemble them and then fill the complete unit with brake fluid as soon as possible in order to prevent attacks from rust through moisture in the air. This applies to units which are to be immediately installed in the vehicle. To counteract corrosion on brake components which are put in

stock, pistons, cylinders and seals should be coated with a light layer of brake paste. Under no circumstances whatsoever may other types of grease or rustproofing oil be used.

Brake fluid

Only first-class brake fluid which is guaranteed by a well-known manufacturer to meet the requirements according to the standard SAE J 1703 or DOT 3 may be used for the brake system.

When filling the brake fluid reservoirs, as well as with all work with connections, etc, observe the greatest cleanliness in order to prevent dirt getting into the system. The system should only be filled with clean, unused brake fluid. Any brake fluid that is expelled during bleeding may not be put back into the system.

After being in use a long time, it is normal that even first-class brake fluid gradually deteriorates due to the absorption of moisture and minor impurities. Thus, deteriorated brake fluid can be recognized by the fact that, compared with new brake fluid, it is darker or has altered its colour, it is relatively free from the smell which new brake fluid has, and when rubbed between the fingers it lacks the normal feeling of a light lubricating film. Such brake fluid should be replaced with new brake fluid. This also applies after doing any reconditioning on the master cylinder and wheel cylinders.

Brake test with roller tester

1. With the engine at idle (servo assistance), check both the front wheel brakes and the rear wheel brakes for the following:
 - a. Smooth operation.
 - b. Maximum braking power. Total braking power minimum 15000 N (1500 kp = 3300 lbf) at 300 N (30 kp = 66 lbf) brake pedal force.
 - c. Brake application time. Braking should be obtained within 1/2 second after the brake pedal has been depressed.
 - d. Brake release time. Braking power 0 within 1/2 second after brake pedal has been released.
 - e. Check that the contact for the brake pedal travel is functioning properly by switching in the circuit by hand.

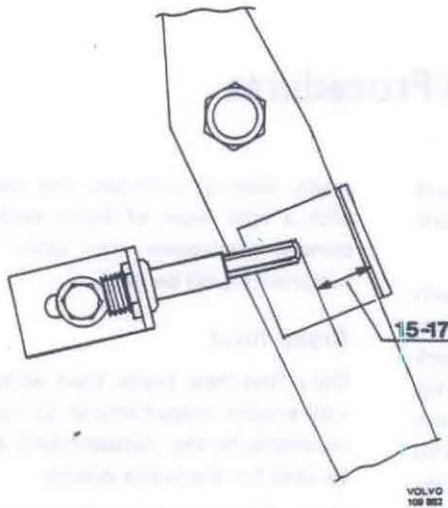


Fig. 50-4. Contact for brake pedal travel

If a fault is discovered during the test, supplementary fault tracing can be done by repeating the checks with the engine switched off (that is without servo assistance).

NOTE! Re-set the contact for the brake pedal travel by pushing the pin back to the rest position.

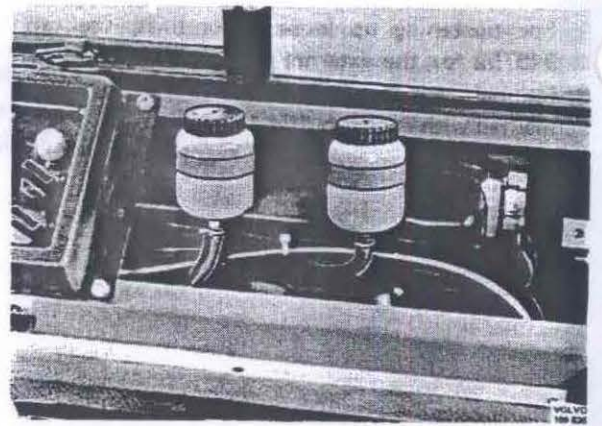


Fig. 50-5. Brake fluid reservoirs

Hydraulic test with test device

Special tool: 2741 Test device

Check to make sure that the brake fluid reservoirs are full, see Fig. 50-5.

Unscrew the bleeder nipples at rear wheels and connect it to the test device shown on Fig. 50-2. Connect up according to Fig. 50-6. If necessary, bleed the test device.

Depress the brake pedal several times in order to even out any vacuum in the servo units and in this way disengage them.

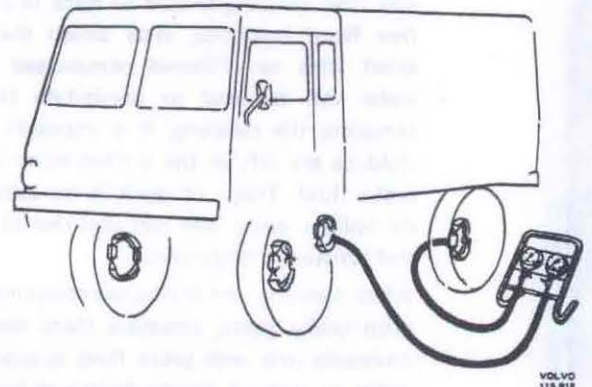


Fig. 50-6. Connecting up the test device

Leakage and pressure checks

2. With a pedal jack on the brake pedal, apply the service brakes to a hydraulic brake pressure of about 10 MPa ($100 \text{ kp/cm}^2 = 1422 \text{ lbf/in}^2$). Check lines and components for damage and leakage. The pressure should remain unchanged for at least 15 seconds.
3. Remove the brake pedal jack. Apply and release the footbrake while reading the test device gauges. The pressure in both the circuits should be similar. At 10 MPa ($100 \text{ kp/cm}^2 = 1422 \text{ lbf/in}^2$), the pressure in both the circuits may not differ more than 0.3 MPa ($3 \text{ kp/cm}^2 = 43 \text{ lbf/in}^2$). The pressure should drop to about 0.1 MPa ($1 \text{ kp/cm}^2 = 14 \text{ lbf/in}^2$) within 1/2 second after the pedal has been released.
4. Start the engine and stop it after it has been run at least 1 minute. Adjust the brake pedal jack to a hydraulic pressure of 2.5 MPa ($25 \text{ kp/cm}^2 = 355 \text{ lbf/in}^2$). Wait 2 minutes. The hydraulic pressure should not alter during this time more than 0.5 MPa ($5 \text{ kp/cm}^2 = 71 \text{ lbf/in}^2$).

Warning valve (only Swedish market)

Disconnect the electric cable from the contact for the pedal travel, see Fig. 50-7.

5. Depress the brake pedal several times in order to disengage the servo units. Connect a hose to one of the bleeder nipples on the test device and open the nipple. Turn the ignition key and check that the warning lamp goes on when the parking brake is applied.

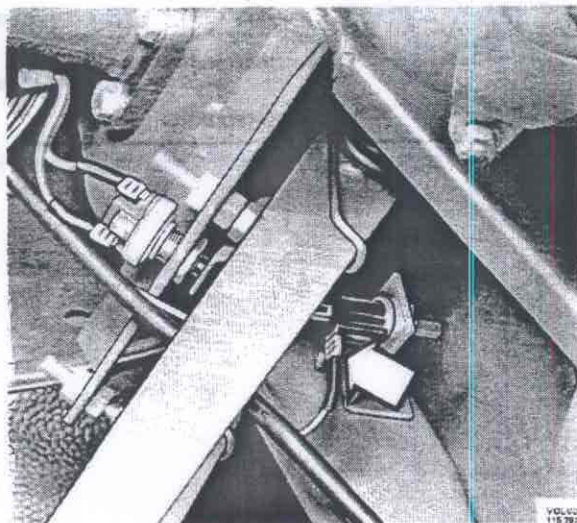


Fig. 50-7. Contact for pedal travel

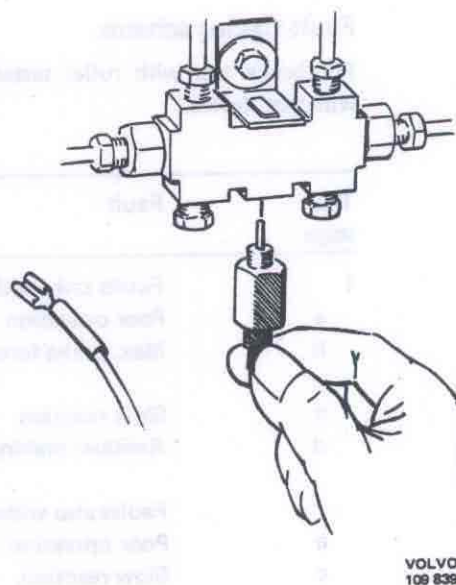


Fig. 50-8. Removing the contact

Release the parking brake. Carefully apply the service brakes with a brake pedal jack. When the warning lamp goes on, check the pressure on the gauge. The lamp should light at a pressure difference of 0.5–1.5 MPa ($5\text{--}15 \text{ kp/cm}^2 = 71\text{--}108 \text{ lbf/in}^2$) between the circuits.

After the test, close the bleeder nipple and remove the brake pedal jack. Connect the contact for the pedal travel. NOTE: Disconnect the electric cable and screw out the contact, Fig. 50-8, so that the warning valve returns to normal position. Screw in the warning contact carefully (approx. $15 \text{ Nm} = 1.5 \text{ kpm} = 11 \text{ lbf} \cdot \text{ft}$). Reconnect the electric cable.

Servo units

6. Depress the brake pedal several times to disengage the servo units. Apply the service brakes with a brake pedal gauge to a hydraulic pressure of 2 MPa ($20 \text{ kp/cm}^2 = 284 \text{ lbf/in}^2$). Read off the brake pedal gauge. Start the engine and apply the brakes until the brake pedal gauge gives the same reading as before. Read off the hydraulic gauge, which will then indicate the servo pressure. At maximum servo effect, the pressure should be 8 MPa ($80 \text{ kp/cm}^2 = 1138 \text{ lbf/in}^2$), that is a reduction of 1:4.

Fault-tracing scheme

For brake test with roller tester and hydraulic test with test device.

Test stage	Fault	Reason
1	Faults only with servo assistance	
a	Poor operation	Servo units
b	Max. brake force too low,	one wheel both wheels
		Wheel brake Servo units
c	Slow reaction	Servo units
d	Residual braking	Servo units
	Faults also without servo assistance	
a	Poor operation	Wheel brakes
c	Slow reaction,	one wheel both wheels
		Wheel brake Master cylinder or wheel brakes
d	Residual braking,	one wheel both wheels
		Wheel brake Master cylinder or wheel brakes
2	Pressure drops	Leaking brake line Wheel cylinder Master cylinder
3	Lagging pressure Brake-release period greater than 1/2 second	Pinched brake line Wheel cylinders Master cylinder
4	Pressure drops more than 0.5 MPa (5 kp/cm ² = 71 lbf/in ²)	One-way valve Servo units
	Pressure increases more than 0.5 MPa (5 kp/cm ² = 71 lbf/in ²)	Servo units
5	Parking brake warning lamp does not go on Service brakes warning lamp does not go on Warning at pressure difference other than 0.5–1.5 MPa (5–15 kp/cm ² = 71–213 lbf/in ²) Warning lamp does not go out after being re-set	Electrical components Contact on warning valve Warning valve Warning valve
6	Faulty servo pressure	Servo units

Brake test without aids

1. Check to make sure that the brake fluid reservoirs are full, see Fig. 50-5.
2. Examine the brake lines and parts for damage and leakage.
3. Depress the brake pedal several times to even out any vacuum in the servo units and in this way disengage them.
4. Depress the brake pedal. Start the engine. You should clearly feel the pedal dropping when the servo units are functioning.
5. Open a bleeder nipple. Turn the ignition key and check that the warning lamp goes on when the parking brake is applied. Release the parking brake. Carefully apply the service brakes until the warning lamp goes on. If it does not, change the contact, see Fig. 50-9.

After the test close the bleeder nipple.

NOTE! Disconnect the electric cable and screw out the contact, see Fig. 50-9, so that the warning valve returns to normal position. Screw in the contact carefully (approx. 15 Nm = 1.5 kpm = 11 lbftf).

Connect up the electric cable.

6. Check that the contact for the brake pedal travel is functioning by closing it with the hand. Then re-set the contact by pushing the pin back to the rest position.

7. Raise the vehicle so that the wheels are off the ground. Get someone to rotate the wheels and apply and release the brakes. The wheels should not be braked a half second after the pedal has been released. This test should be carried out with and without vacuum in the servo unit.

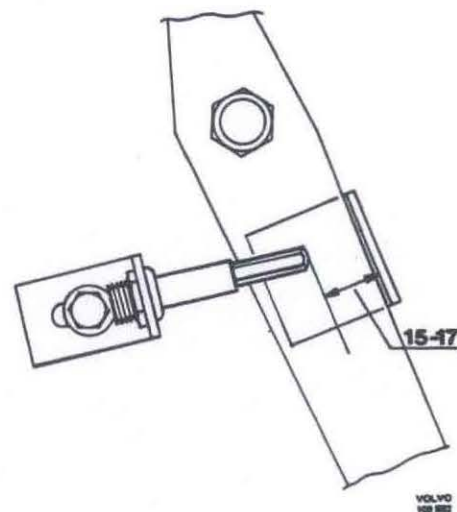


Fig. 50-10. Contact for brake pedal travel

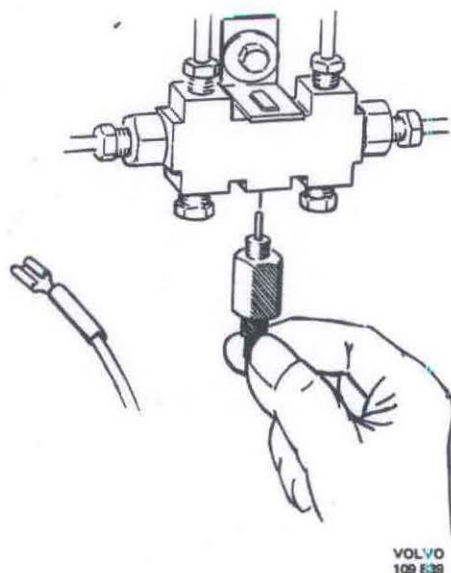


Fig. 50-9. Removing the contact

GROUP 51 BRAKE SHOES, DRUMS AND LININGS

Description

The front wheel brake unit (see Fig. 51-1) has two single-operating wheel cylinders. This means that both shoes function as primary shoes.

The rear wheel brake unit (see Fig. 51-2) has a double-operating wheel cylinder. At the bottom the shoes rest against a support fixed to the brake backing plate.

The shoes can be displaced radially, they are therefore self-centering. The clearance between the brake lining and drum can be adjusted with a rotatable eccentric. The brake linings are bonded.

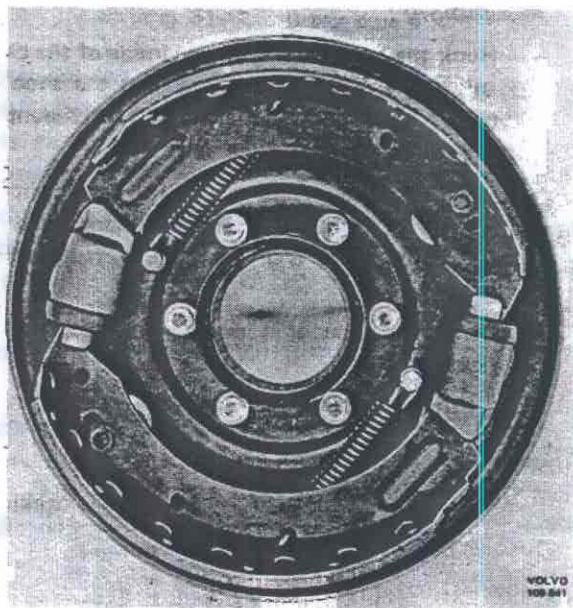


Fig. 51-1. Front wheel brake unit, left

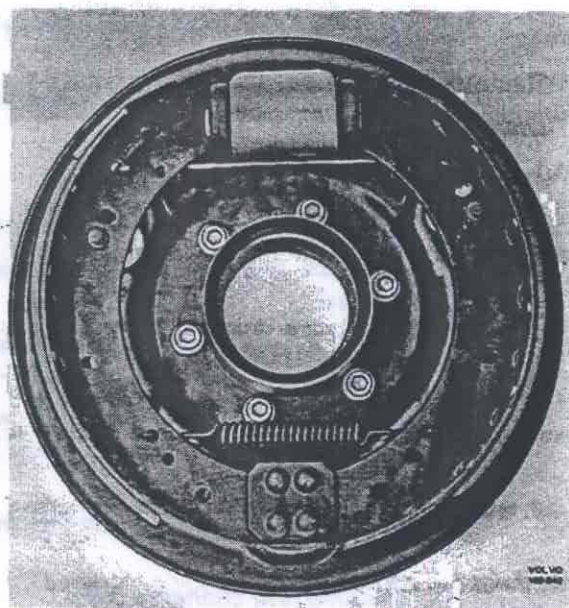


Fig. 51-2. Rear wheel brake unit, left

Service Procedures

Adjusting the wheel brakes

Special tool: 6127 Spanner, rear wheel brakes

1. Jack up the vehicle or at least one axle.
2. Turn the adjuster pin clockwise until the brake drum can just be rotated, see Fig. 51-3. For the rear wheels use spanner 6127 and for the front wheels an 11/16" spanner.
3. Slacken the adjuster pin until the drum can rotate freely.
4. Repeat this with the other adjuster pin and the other wheels.

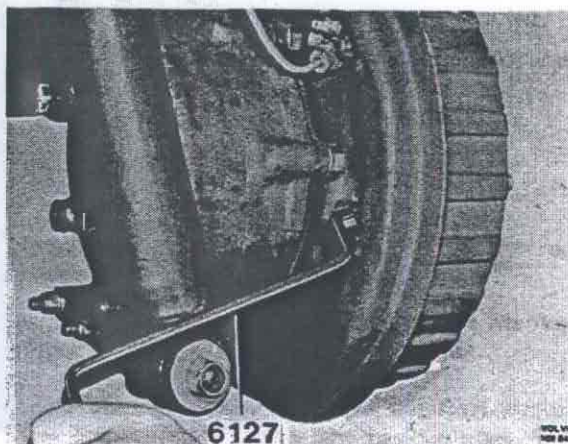


Fig. 51-3. Adjusting the wheel brake unit

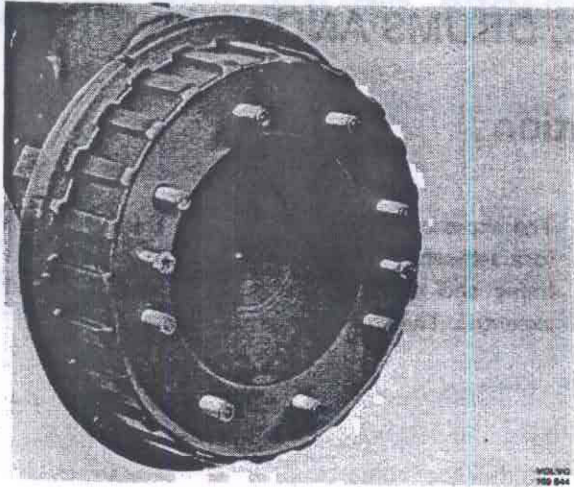


Fig. 51-4. Puller bolts in brake drum

Reconditioning the front wheel brakes

Dismantling

1. Slacken the wheel nuts a bit.
2. Jack up the front end and remove the wheel.
3. Adjust back both the brake shoes (anti-clockwise).
4. Pull off the brake drum. If necessary use two puller bolts 3/8-24 UNF, Fig. 51-4.
5. With a screwdriver or torque wrench lift the brake shoes out of their grooves in the cylinder housing, Fig. 51-5.
6. Unhook the springs and lift forward the shoes.

Checking and changing parts

Clean the brake components and the king pin location for the brake drum.

The wheel cylinder is dealt with under the heading "Wheel cylinder", Group 52.

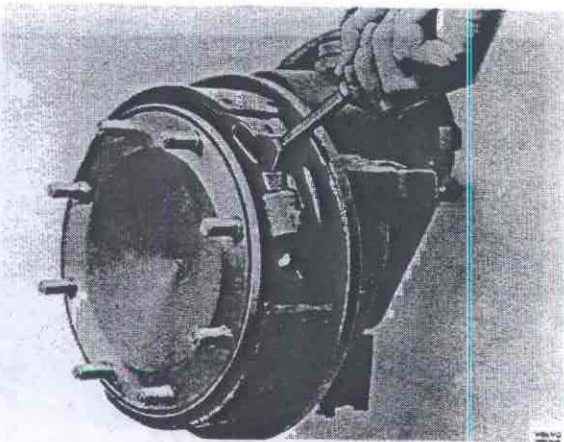


Fig. 51-5. Removing the brakes shoes

If the brake backing plate or the adjuster mechanisms are damaged, replace the plate. The king pin must be removed to do this, see under the heading "Wheel hub", Group 78.

If the brake linings are oily, damaged or worn so that there is not more than about 1.5 mm (1/16") of the lining thickness remaining, replace the shoes complete.

Check the friction surface and out-of-roundness of the brake drums. The out-of-roundness may not exceed 0.1 mm (0.004").

The friction surface can be machine-smoothed or ground but the diameter may not exceed 282.4 mm (11").

Assembling

1. Hook the return spring on the inside of the brake shoes, see Fig. 51-7. Check that the shoe pin comes inwards since the shoes are different on the left-hand and right-hand sides.
2. Place the shoe on the inside of the king pin and hook the return spring on the backing plate pin. Carefully fit the end of the shoe on the piston groove.
3. Tension the shoe in position in the cylinder housing groove.
4. Fit the other brake shoe in the same way.

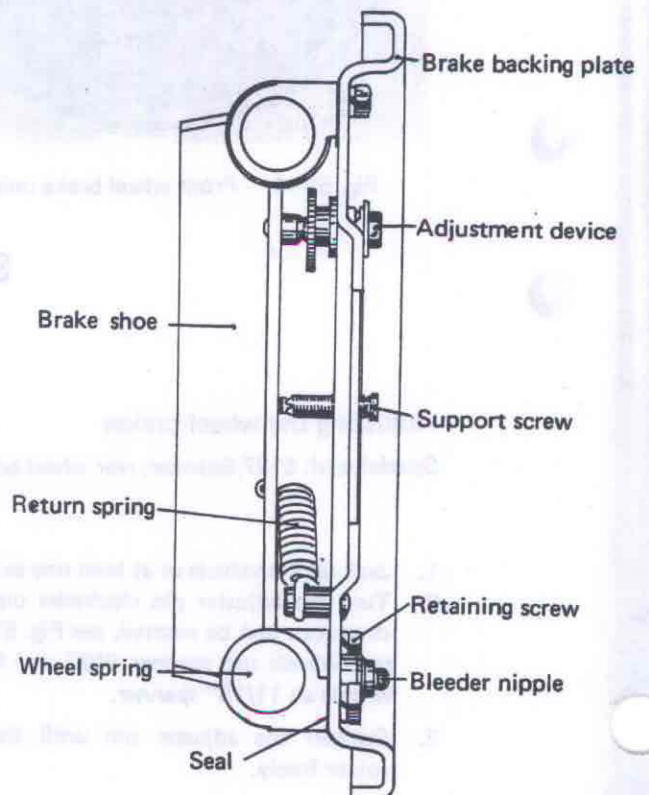


Fig. 51-6. Front wheel brake parts



Fig. 51-7. Brake shoe

5. Check that the linings are at right angles to the king pin, see Fig. 51-8. To adjust use the support screw in the backing plate. Tighten up after adjusting.
6. Fit the brake drum. Make sure that it is fitted properly in position with the help of the two nuts.
7. Adjust the wheel brake unit.
8. Fit the wheel, lower the front end and tighten the wheel nuts to a torque of 160–210 Nm (16–21 kpm = 115–152 lbftf).

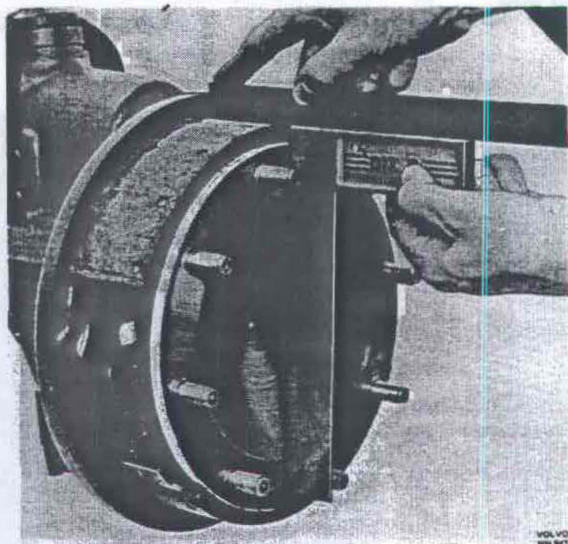


Fig. 51-8. Checking the right angle

Servicing the rear wheel brakes

Special tool: 6118 Protective bracket for wheel cylinder.

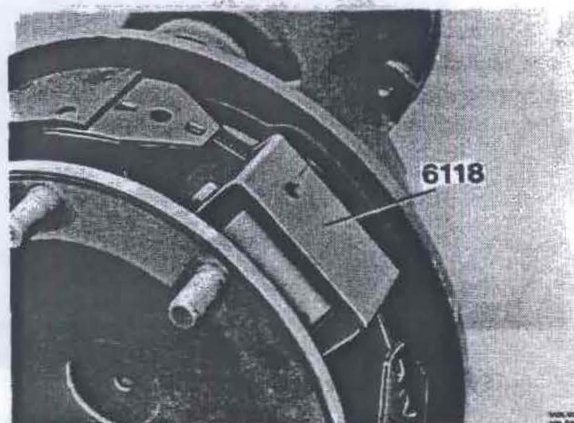


Fig. 51-9. Safety bracket

Dismantling

1. Slacken the wheel nuts a bit.
2. Jack up the rear end and remove a wheel.
3. Adjust back both the brake shoes (anti-clockwise).
4. Pull off the brake drum. If necessary use two puller bolts 3/8–24 UNF, see Fig. 51-4.
5. Lever out the shoes a bit at the top and place the protective bracket 6118 on the wheel cylinder, see Fig. 51-9.
6. Lever out the shoes from the guide at the bottom with two screwdrivers, see Fig. 41-10, or torque wrench.
7. Move the upper ends of the shoes to the side of the pistons and remove the protective bracket.
8. Unhook the upper spring with flat pliers. Pull forward the shoes.

Checking and replacing parts

Clean the brake parts and the king pin location for the brake drum.

The wheel cylinder is dealt with under the heading "Wheel cylinder", Group 52.

If the brake backing plate or the adjusting mechanisms are damaged, replace the backing plate. The king pin must be removed in order to do this, so see under the heading "Wheel hub", Group 78.

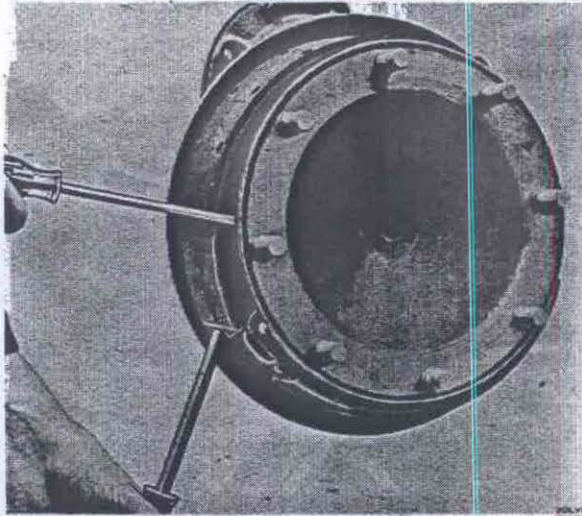


Fig. 51-10. Removing the brake shoes

If the brake linings are oily, damaged or worn so that there is not more than about 1.5 mm (1/16") of lining thickness remaining, replace the shoes complete.

Check the brake drum friction surface and out-of-roundness. The out-of-roundness may not exceed 0.1 mm (0.004").

The friction surface can be machine-smoothed or ground but the diameter may not exceed 282.4 mm (11").

Assembling

1. Hook the lower return spring on both the shoes and the upper on one of the shoes, see Fig. 51-11. Note that the lining on the primary shoe (the leading) is displaced downwards.

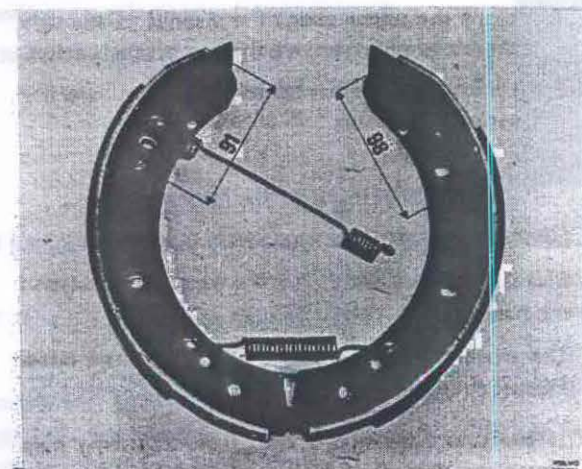


Fig. 51-11. Brake shoes

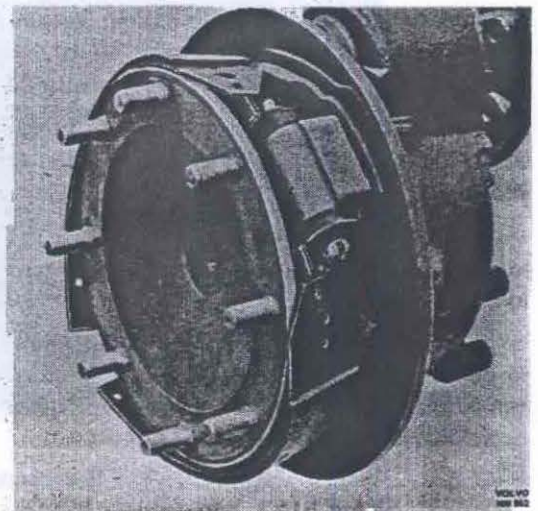


Fig. 51-12. Fitting the brake shoes

2. Fit the shoes on the inside of the king pin, see Fig. 51-12. Hook on the upper return spring with flat pliers.
3. Place the protective bracket 6118 on the wheel cylinder, see Fig. 51-13.
4. Carefully fit the shoes on the grooves on the pistons.
5. Tension out the shoes at the bottom so that they can be fitted in the guide.
6. Lever out the shoes a bit and remove the protective bracket.
7. Fit the brake drum. Make sure that it is fitted properly and align it with the help of two nuts.
8. Adjust the wheel brake unit.
9. Fit the wheel, lower the rear end and tighten the wheel nuts to a torque of 160–210 Nm (16–21 kpm = 115–152 lbftf).

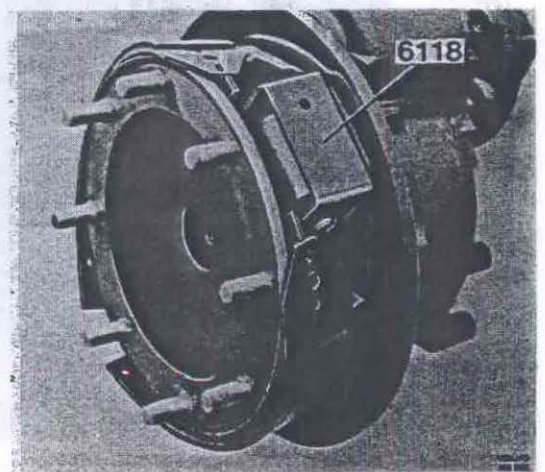


Fig. 51-13. Protective bracket

GROUP 52 HYDRAULIC SERVICE BRAKES

Description

The service brakes (Fig. 52-1) are vacuum-hydraulic. Layout is according to Fig. 52-1. It has two circuits, one of which (the primary circuit) operates on the front wheels and the left, rear wheel, and the other (the secondary circuit) on the front wheels and right, rear wheel. The service brakes have also an auxiliary brake with servo units which boost the hydraulic pressure.

Described on the following pages are the master cylinder, wheel cylinders, brake pedal and the warning devices for the brake system. Described under Group 51 are the brake shoes and brake drums, and under group 54 the servo units.

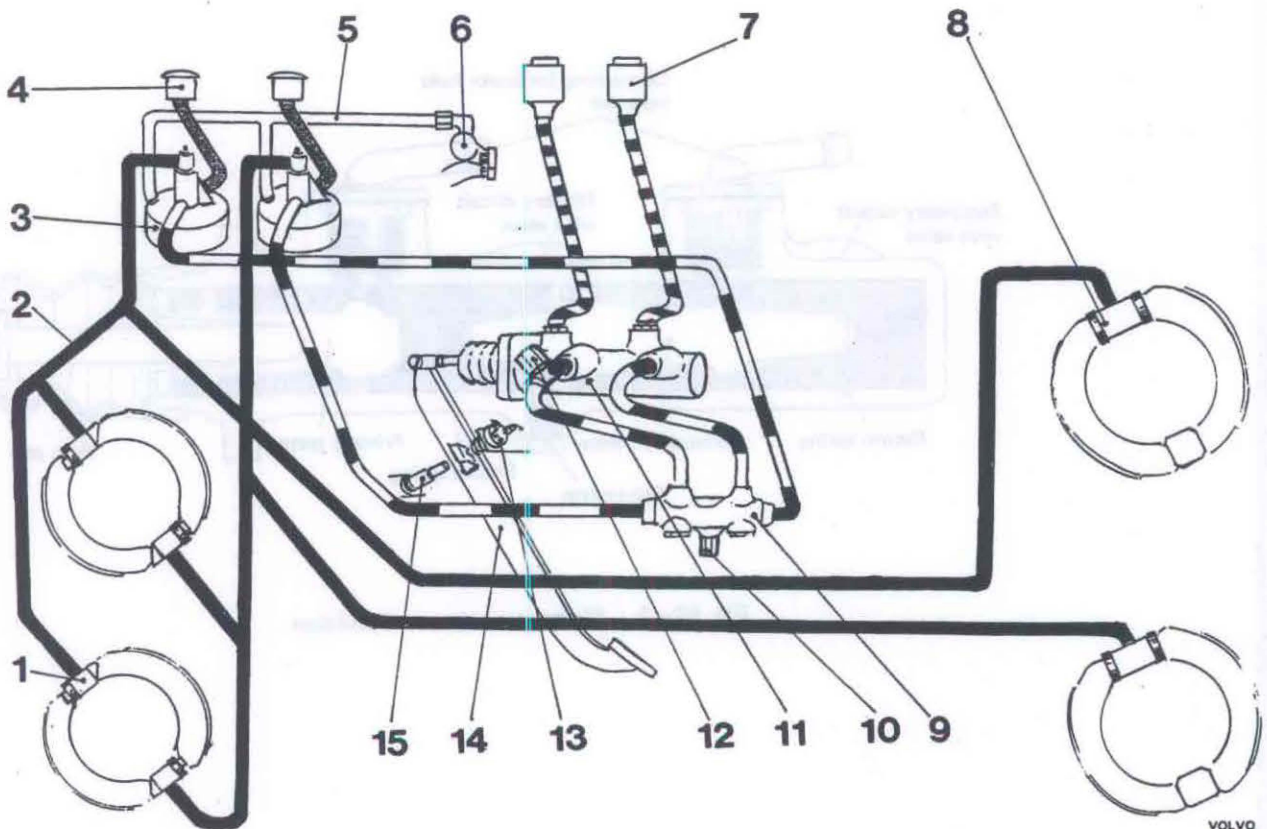
VOLVO
109 854

Fig. 52-1. Service brakes, layout diagram

- | | |
|---------------------------------|-----------------------------------|
| 1. Wheel cylinder, front wheels | 9. Warning valve |
| 2. Brake line | 10. Contact, press. diff. |
| 3. Servo unit | 11. Master cylinder |
| 4. Air cleaner | 12. Contact (only Swedish market) |
| 5. Vacuum line | 13. Contact for stop lights |
| 6. Suction pipe | 14. Brake pedal |
| 7. Brake fluid reservoir | 15. Contact, brake pedal travel |
| 8. Wheel cylinder, rear wheels | |

Colour marking

- | | |
|--------|----------------------------------|
| Red | = brake fluid, primary circuit |
| Blue | = brake fluid, secondary circuit |
| Purple | = air |

Pressure marking on lines

- | | |
|-----------------|----------------------------|
| Uncoloured | = vacuum |
| Short dashes | = atmospheric pressure |
| Long dashes | = master cylinder pressure |
| Continuous line | = servo pressure |

MASTER CYLINDER

The master cylinder design can be seen from Fig. 52-2. It functions as follows:

In the rest position, the pistons are held back by spring pressure. The connection is then open in both circuits between the brake fluid reservoir and the space in front of the piston. During braking the primary piston (right on Figure) is pushed in by the push rod. This closes the connection with the reservoir and the pressure in front of the piston rises.

This pressure actuates the secondary piston and pushes it to the left. The same overpressure arises in front of both the pistons, the brake fluid is pressed out into the brake lines and all the wheel brakes are applied, providing the system is without fault.

When the brake pedal is released, the pistons return to the rest position. Both the valves at the outlets result in a low, hydraulic overpressure remaining in the circuits outside the master cylinder.

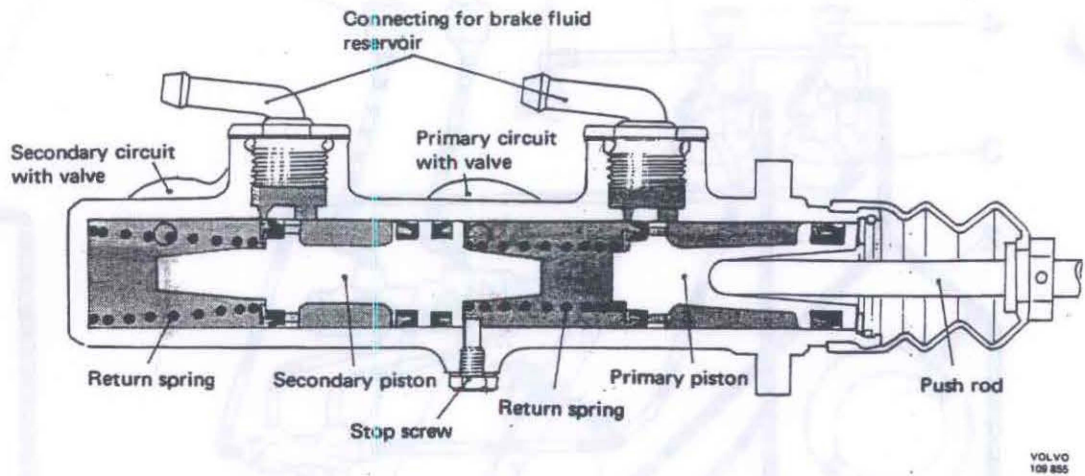


Fig. 52-2. Master cylinder, rest position

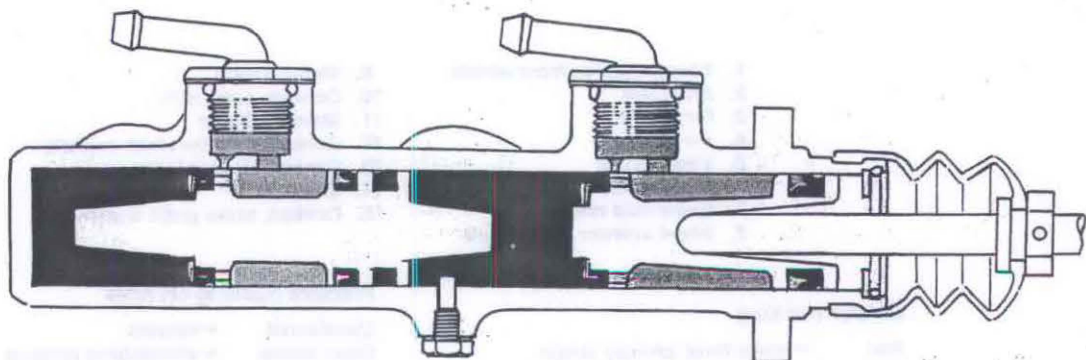


Fig. 52-3. Normal brake application

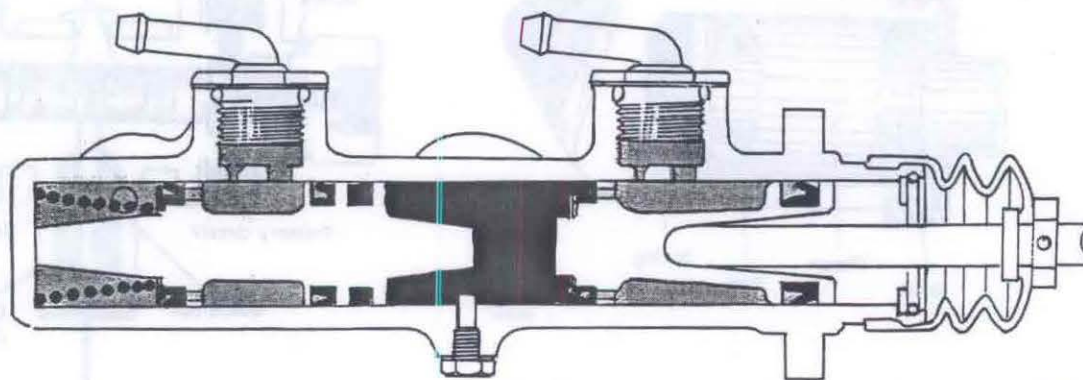
VOLVO
109 857

Fig. 52-4. Brake application with leakage in secondary circuit

If a leakage has arisen in the secondary circuit, no backpressure is formed in front of the secondary piston which is pushed inwards during brake application until stopped by the end of the cylinder. The hydraulic pressure between the pistons can thereafter rise and apply the brakes in the primary circuit.

If there is a leakage in the primary circuit, the primary piston is displaced during braking until it makes contact with the secondary piston. Both pistons are then pushed inwards, the pressure in front of the secondary piston rises and the brakes in the secondary circuit are applied.

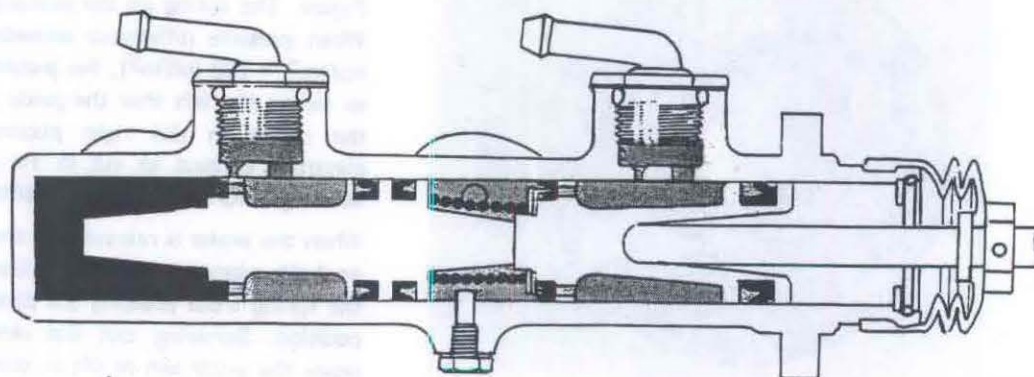
VOLVO
109 858

Fig. 52-5. Brake application with leakage in primary circuit

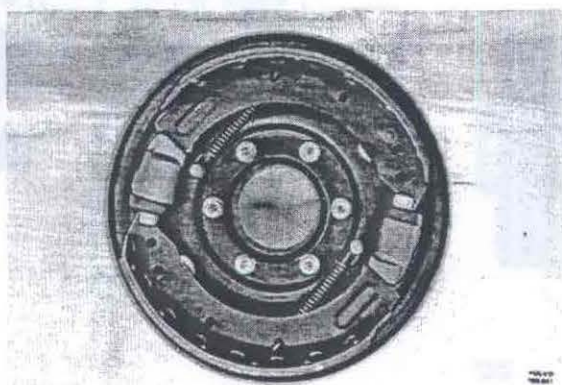
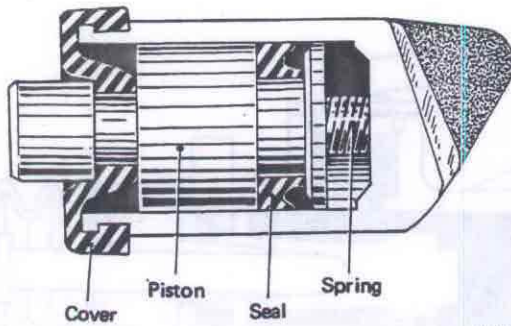


Fig. 52-6. Front wheel brake unit

WHEEL CYLINDERS

Each front wheel has two wheel cylinders. Fig. 52-6 shows the location and Fig. 52-7 the design. The leading cylinder is connected to the secondary circuit, the trailing to primary circuit. During braking, brake fluid pushes the piston outwards and applies one of the brake shoes. In the rest position, the piston is held pressed-in by the shoe's return spring.



VOLVO
109 859

Fig. 52-7. Wheel cylinder, front wheels

Each rear wheel has a wheel cylinder. Fig. 52-8 shows the location and Fig. 52-9 the design. During braking, brake fluid pushes the piston outwards and the brake shoes are applied. In the rest position, the pistons are held pressed-in by the return springs for the shoes.

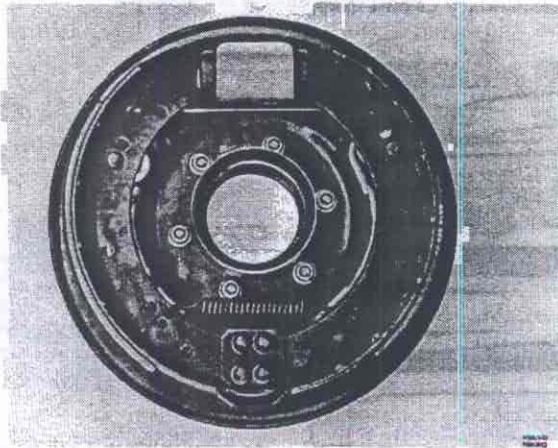
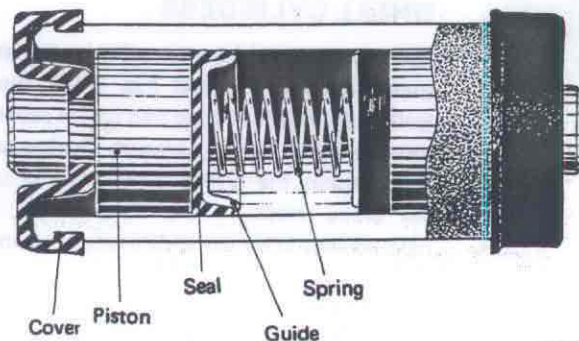
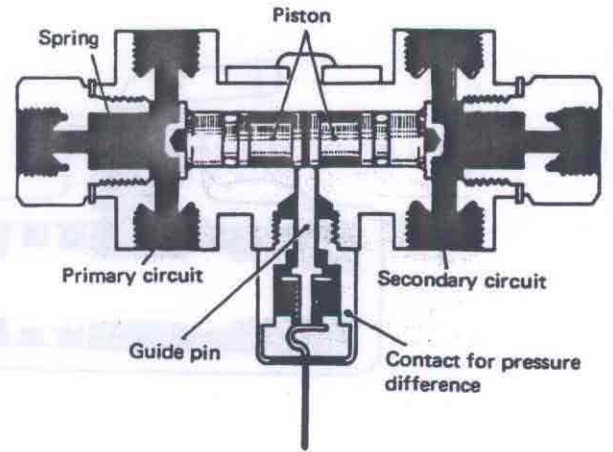


Fig. 52-8. Rear wheel brake unit



VOLVO
109 860

Fig. 52-9. Wheel cylinder, rear wheels



VOLVO
109 862

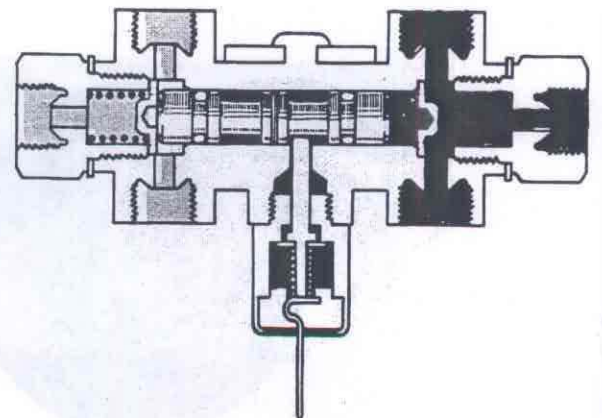
Fig. 52-10. Warning valve, normal position

WARNING VALVE

The warning valve design can be seen from Fig. 52-10. Concerning the electrical contacts for this valve, see Group 38.

During normal braking, pressure on both pistons is more or less the same. If the pressure in the secondary circuit is higher than that in the primary circuit, the pistons are pushed to the left on the Figure. The spring on the primary side opposes this. When pressure difference exceeds about 1 MPa (10 kp/cm² = 142 lbf/in²), the pistons have been pushed so far to the left that the guide pin goes down into the recess in the right piston. This causes the electrical contact to cut in the current so that the warning lamp for the pressure difference goes on.

When the brake is released and the hydraulic pressure on both pistons is the same, the guide pin prevents the spring from pressing the pistons back to normal position. Screwing out the electrical contact will cause the guide pin to lift so that the pistons return to normal position. The electrical contact should always be screwed out after warning position (and when bleeding) in order not to damage the guide pin and piston.



VOLVO
109 863

Fig. 52-11. Warning position

BRAKE PEDAL

The brake pedal is suspended, journalled in two bushings. The upper section actuates the push rod in the master cylinder. A stop bolt limits return travel.

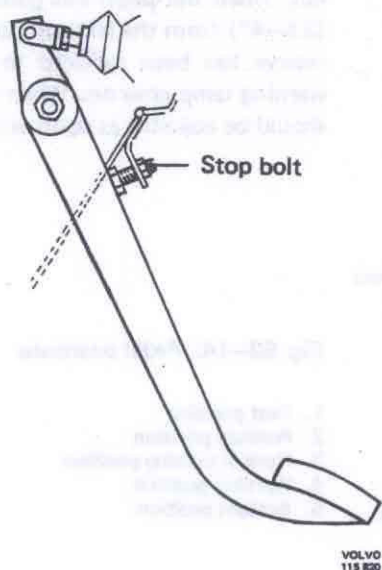


Fig. 52-12. Brake pedal

BRAKE SYSTEM WARNING DEVICES

Concerning the electrical part of the contacts, see Group 38. The location and connection of the electrical contacts can be seen from Fig. 52-13.

Contact for stop lights

The contact is mechanical and is actuated by the brake pedal. When the pedal is in rest position, there is no current to the lights. When the pedal is depressed, current is cut in to the stop lights.

Contact for pressure difference

The contact is actuated by the warning valve. See under "Warning valve".

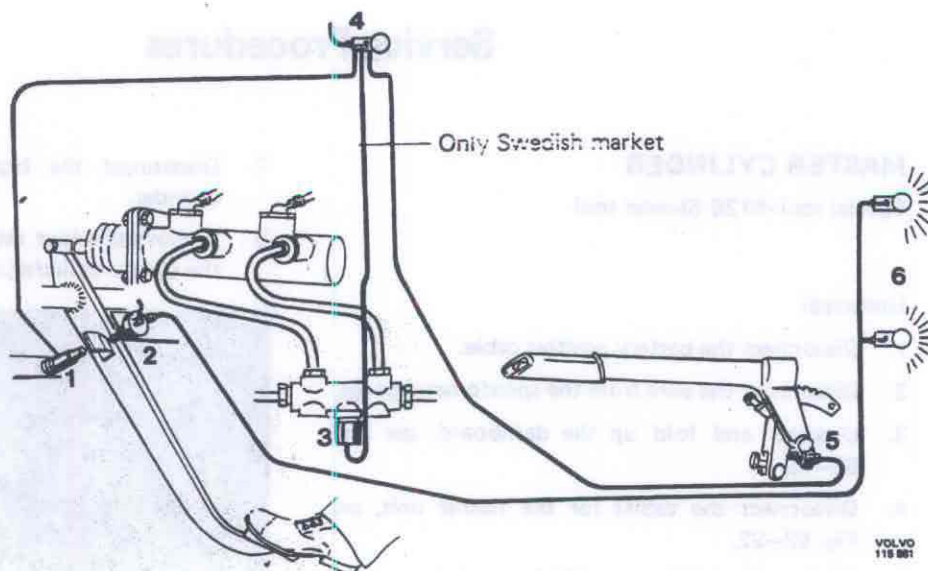
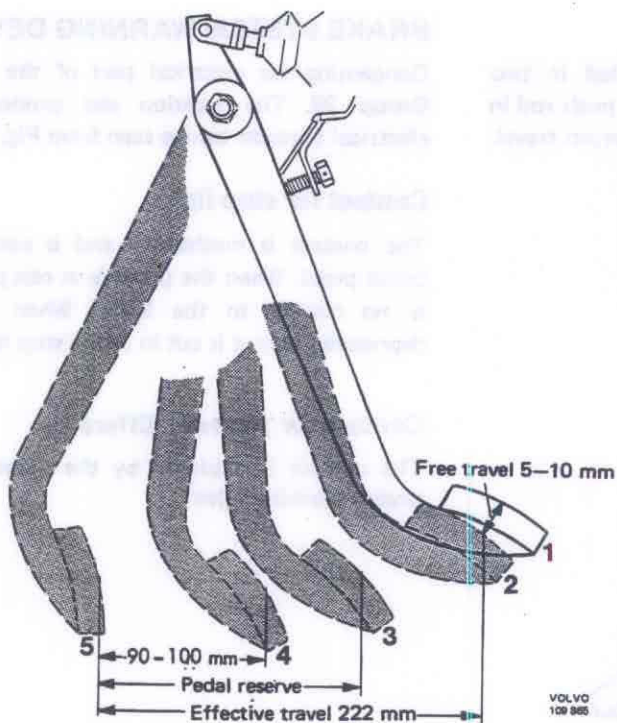


Fig. 52-13. Warning devices

- | | |
|---------------------------------|-------------------------------|
| 1. Contact, brake pedal travel | 4. Warning lamp, brake system |
| 2. Contact, stop lights | 5. Contact, parking brake |
| 3. Contact, pressure difference | 6. Stop lights |



Contact for brake pedal travel

The contact is actuated by the pedal. The more the brake linings wear down, the greater will be the pedal travel. However, the pedal must not travel too far if the brakes are to function should one of the circuits fail. When the pedal has gone down to 90–100 mm (3.5–4") from the bottom position, that is, the pedal reserve has been reduced to this measurement, the warning lamp goes on. When this happens, the brakes should be adjusted as soon as possible.

Fig. 52–14. Pedal positions

1. Rest position
2. Pressure position
3. Normal braking position
4. Warning position
5. Bottom position

Service Procedures

MASTER CYLINDER

Special tool: 6126 Bleeder tool

Removal

1. Disconnect the battery positive cable.
2. Disconnect the wire from the speedometer gauge.
3. Unscrew and fold up the dashboard, see Fig. 52–15.
4. Disconnect the cables for the flasher unit, see Fig. 52–22.
5. Remove the padded panel in front of the steering column.
6. Place an empty vessel under the master cylinder. Remove the hoses from the master cylinder and plug them. To slow up the oil running out temporarily cover the breather hole in the cap of the brake fluid reservoirs with plastic cement or similar.

7. Disconnect the brake lines from the master cylinder.
8. Remove the four retaining bolts and lift forward the master cylinder, see Fig. 52–16.

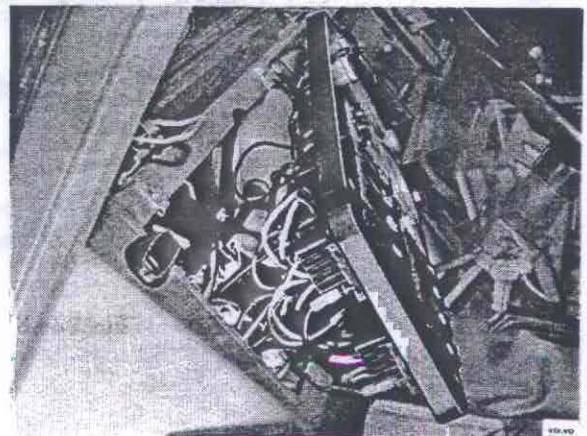


Fig. 52–15. Dashboard folded up

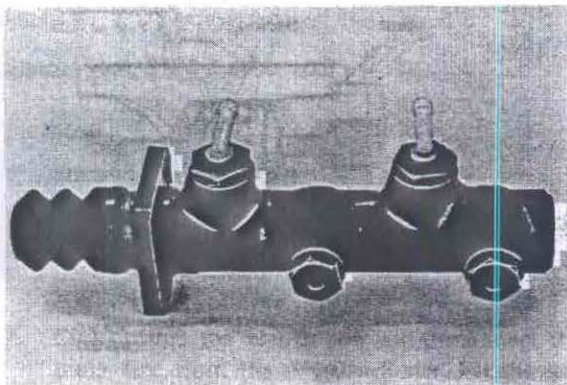


Fig. 52-16. Master cylinder removed

Dismantling

1. Fix the master cylinder flange securely in a vice.
2. Unscrew the connections for the brake fluid reservoirs.
3. Unscrew the output connections and remove the valves.
4. Unscrew the stop bolt.
5. Lever off the rubber cover and remove the push rod.
6. Remove the lock ring for the primary piston with the help of lock ring pliers. Shake out the valves, use compressed air if necessary.
7. Remove the parts from the pistons.

Checking and replacing parts

Before checking, clean the parts according to the instructions given under "Cleaning", Group 50.

Examine carefully the inside of the cylinder. If scored or damaged in any other way replace the cylinder. Rusting or similar can generally be removed by honing, etc. Clean the cylinder carefully after honing and check that all holes are open.

If wear is suspected on the cylinder or piston, measure the diameter with a micrometer or dial indicator. The cylinder bore may not exceed 28.68 mm (1.13") and the piston diameter may not be less than 28.42 mm (1.12").

Each time reconditioning is carried out, replace the used repair kit parts with new ones. The stop bolt, lock ring and all seals should also be replaced.

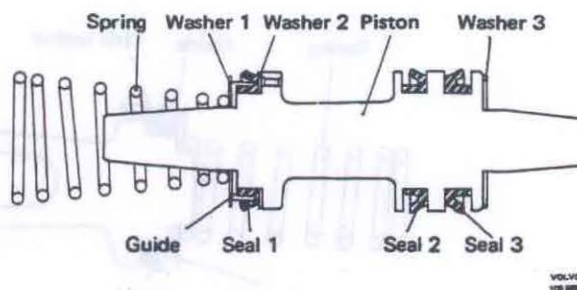


Fig. 52-17. Secondary piston

Assembling

Before assembling, coat the parts with brake paste.

1. Fit the thin washers 2, Fig. 52-17 and the seals on the secondary piston and make sure that the seals are turned correctly according to the Figure.
2. Fit the guide, washers 1 and 3 and the spring on the secondary piston, see Fig. 51-17. Carefully fit the piston in the cylinder. Use a feeler gauge for the seals, see Fig. 52-18.
3. Press in the piston and fit the stop bolt together with a new sealing washer.
4. Fit all the primary piston parts, see Fig. 52-19. Carefully insert the piston in the cylinder. Push in the pistons and fit the thrust washer and lock ring in position on the outside of the primary piston. This is made easier if the primary piston is held pressed in with the help of a 3 mm (1/8") drift through the by-pass hole.

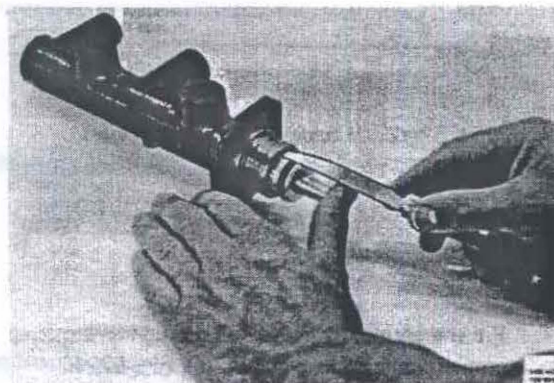


Fig. 52-18. Fitting the piston

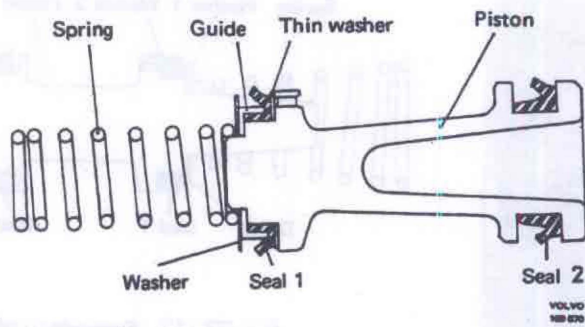


Fig. 52-19. Primary piston

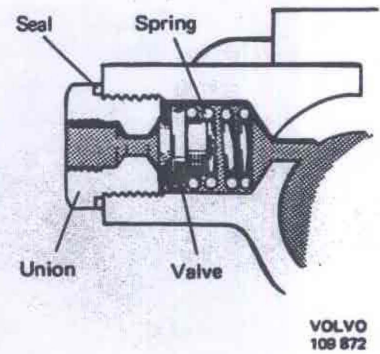


Fig. 52-21. Valves

5. Check the travel of the pistons and make sure that the through-flow holes are not blocked. Check the equalizing holes by inserting a soft copper wire with diameter 0.5 mm (1/64"), compare Fig. 52-20. If an equalizing hole is blocked, then generally the master cylinder has been incorrectly assembled.
6. Place in position the push rod and rubber cover.

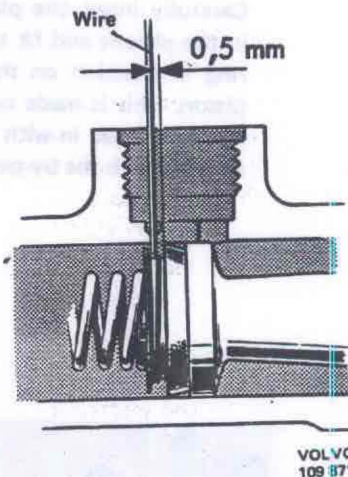


Fig. 52-20. Checking equalizing holes

Copper wire = 0.5 mm (1/64")

Installing

1. Place the master cylinder in position. Tighten up the retaining bolts.
2. Fit the clamps and connect the hoses from the brake fluid reservoirs.
3. Pump with the brake pedal until brake fluid free from air bubbles emerges from the primary circuit connection. Connect up the brake line. Pump with the brake pedal until brake fluid free from air bubbles emerges from the secondary circuit connection. Fit the brake line.
4. Run the cable through the hole and install the panel.
5. Connect the cables for the flasher unit as shown in Fig. 52-22.
6. Connect the wire to the speedometer.
7. Install the dashboard.
8. Connect up the battery.
9. Bleed the brake system, see page 4.

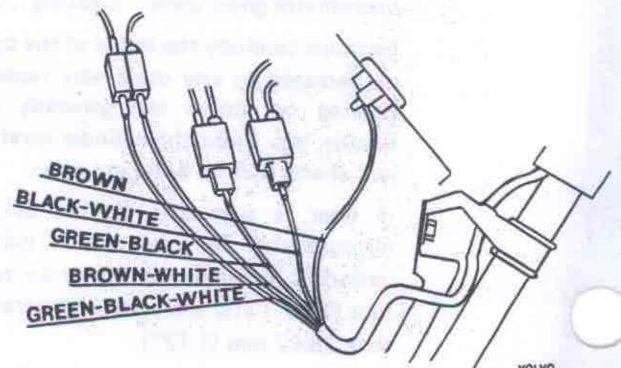


Fig. 52-22. Connecting the cable, flasher unit

7. Fit the spring, valve, seal and plug for the output connections in their places, see Fig. 52-21.
8. Fit the seals and reservoir connections in their places.

WHEEL CYLINDERS

Special tool: 6126 Bleeder tool

Removal

1. Slacken the wheel nuts.
2. Jack up the vehicle and remove a wheel.
3. Adjust back both the brake shoes (anti-clockwise).
4. Clean round the connection and disconnect the brake line from the wheel cylinder. Fit the seal nipple.
5. Pull off the brake drum and remove the brake shoes according to the instructions given under "Front wheel brakes" and "Rear wheel brakes".
6. Remove the wheel cylinder bleeder nipple and retaining nuts. Lift forward the wheel cylinder.

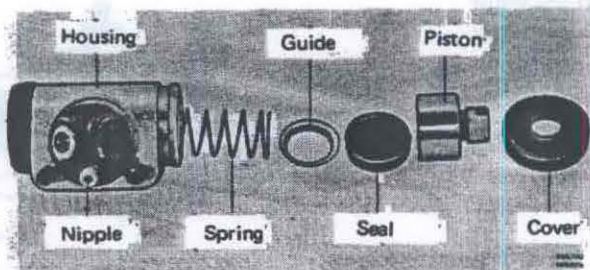


Fig. 52-23. Wheel cylinder parts, rear wheels

Overhauling

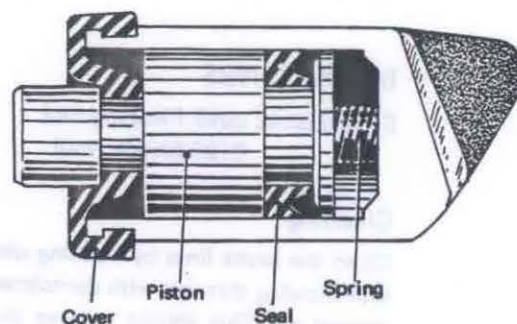
Lever off the rubber cover and take care of the piston and the other parts. Clean all the parts according to the instructions given under "Cleaning".

Examine the inside of the cylinder thoroughly. If scored or damaged in any other way, replace the cylinder. It would be pointless to hone or machine the inside of the cylinder in any other way since this would remove the rustproofing on the inside of the cylinder.

The clearance between the piston and cylinder may not exceed 0.26 mm (0.102") and can be measured with a feeler gauge. If the clearance exceeds 0.26 mm (0.102") try with a new piston. If this does not remedy the situation, replace the wheel cylinder.

Replace the seals and rubber covers each time reconditioning is carried out.

Put together the parts according to Figs. 52-24 and 52-25. Coat the piston and seal, also the groove for the rubber cover, with brake paste.

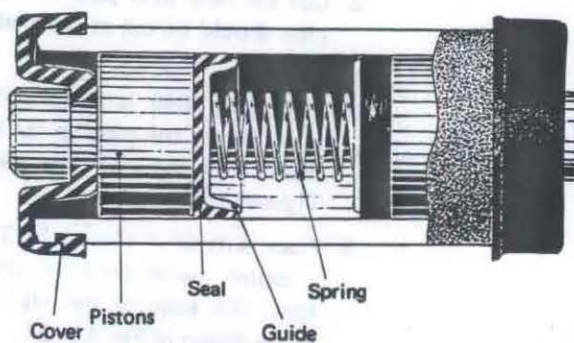


VOLVO
100 800

Fig. 52-24. Wheel cylinder, front wheels

Installing

1. Install the wheel cylinder, and if it applies to the front wheel brake unit also the seal, in position. Fit washers and nuts. Screw on the bleeder nipple.
2. Install the brake shoes according to the instructions given under "Front wheel brakes" and "Rear wheel brakes".
3. Install the brake drum. Adjust the wheel brakes.
4. Connect the brake line to the wheel cylinder.
5. Install the wheel.
6. Remove the seal on the breather hole in the brake fluid reservoir cap. Bleed the wheel brake unit.
7. Lower the vehicle and tighten the wheel nuts to a torque of 160-210 Nm (16-21 kpm = 227-299 lbft).



VOLVO
100 800

Fig. 52-25. Wheel cylinder, rear wheels

BRAKE LINES

Special tools: 2049 Flanging tool
6126 Bleeder tool

Cleaning

Clean the brake lines by flushing with brake fluid and then blowing through with demineralized, filtered compressed air. This should remove old brake fluid and dirt particles.

With full reconditioning, connect the bleeder unit to the master cylinder and then empty the system through the bleeder nipples. Next flush the system with brake fluid and blow it clean with compressed air. Then remove the main components in the hydraulic system and take each of them and thoroughly clean them.

If no bleeder unit is available, empty the lines by disconnecting them at the wheel cylinders and evacuating the brake fluid by pumping with the brake pedal. This will keep the lines blocked alternately so that fluid is pressed out only through one line at a time.

IMPORTANT! Do not fill the system again with drained brake fluid.

Replacing the brake lines

With leakage or when the lines have been exposed to such damage that leakage or pinching can be expected, replace the damaged lines according to the following instructions:

1. To prevent unnecessary loss of brake fluid, temporarily plug the cap on the brake fluid reservoirs with cement or similar.
2. Clean round the connections and remove the damaged brake line. Fit instead sealing nipples.
3. Cut the new steel pipe to the right length. The pipe should be cut at right angles all burr removed.
4. Place tool 2049 in a vice and double flange the pipe. Insert the pipe so far that its end comes flush with the clamping jaw, see Fig. 52-26. Tighten up the nuts.
5. Place drift OP 1 in the tool. Tip on the drift with a copper mallet until the drift goes to the bottom. The edge of the pipe then takes up the shape shown in Fig. 52-27.
6. Replace the drift with drift OP 2 and knock this into the bottom.
7. Fit the connection nuts and repeat points 4-6 at the other end of the pipe.

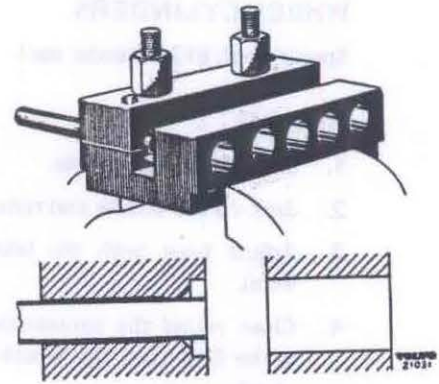


Fig. 52-26. Flanging the brake pipe

8. Bend the new brake line using the old one as a guide. The bending should be done round an object with the same radius as the bend desired.

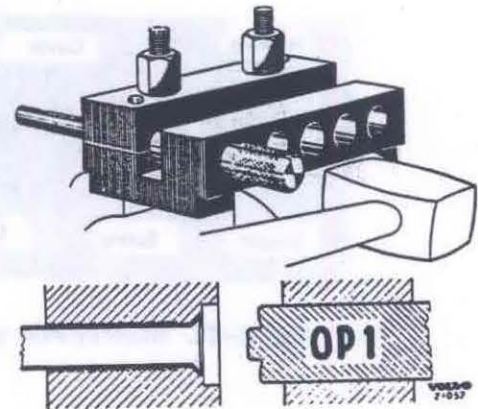


Fig. 52-27. Flanging the brake pipe

9. Blow the inside of the line clean and install it. Make sure that the line is routed so that it will not be damaged during driving.
10. Bleed the brake system. Remove the plug in the hole of the brake fluid reservoir cap.

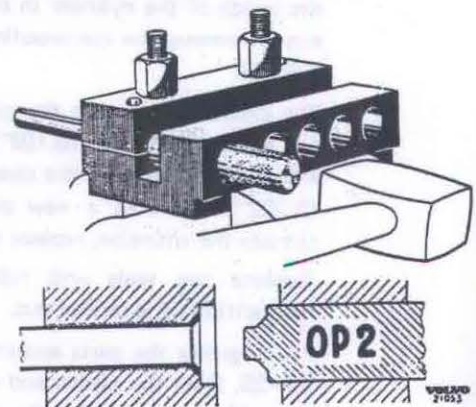


Fig. 52-28. Flanging the brake pipe

BRAKE FLUID RESERVOIRS

Checking the brake fluid level

To get at the brake fluid reservoirs remove the cover, see Fig. 52-29. The left-hand reservoir is for the primary circuit. The reservoirs should be almost full. If necessary top up with brake fluid according to the standard SAE J 1703, that is, Brake Fluid 430 or corresponding.

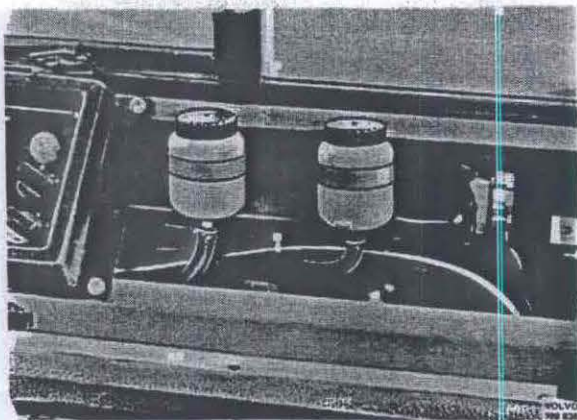


Fig. 52-29. Brake fluid reservoirs

BRAKE PEDAL

Adjusting the pedal position

The free travel, see Fig. 52-30, is the pedal travel from the rest position to the point where its piston in the master cylinder starts operating. If the free travel is too small, the equalizing holes in the master cylinder can be blocked by the piston seals so that the brake shoes are prevented from going back to their rest positions. The free travel is adjusted by means of the stop bolt and should be 5-10 mm (1/4") measured at the footplate. After adjusting tighten the lock nut and check the adjustment for the brake light contact.

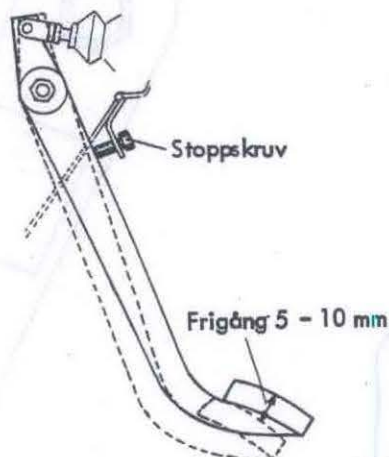


Fig. 52-30. Free travel

PEDAL JOURNALLING

Removing the pedal cover

1. Disconnect the battery positive cable.
2. Remove the retaining screws for the pedal cover.
3. Remove the bolts securing the master cylinder to the casing.
4. Remove the clutch pedal stop and disconnect the wire from the pedal. Remove the wire from the casing.
5. Disconnect the electric cables from the contact for the stop lights and the contact for the brake travel.
6. Lift forwards the pedal cover and pedals.

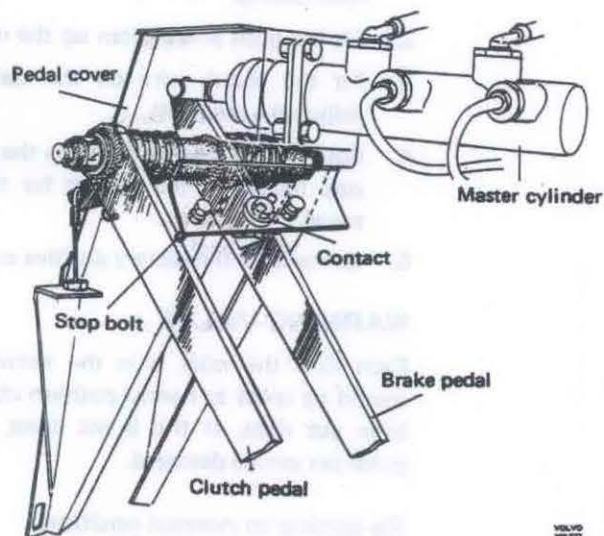


Fig. 52-31. Pedal journaling

Replacing pedal or bushings (loose casing)

1. Unhook the return springs.
2. Remove the nut and washer for the clutch pedal. Remove the pedal and spring.
3. Remove the nut and washer on the corresponding side and drive out the shaft. Lift forward the pedal and spring. Remove the bushing.
4. Clean the parts.
5. Fit new bushing and lubricate them with a light layer of universal grease.
6. Fit the spring on the brake pedal. Place the pedal in the casing and fit the shaft. Fit the washer and nut.
7. Place the clutch pedal spring in the casing. Fit the pedal and washer and tighten up the nut.
8. Hook the springs on the pedals.

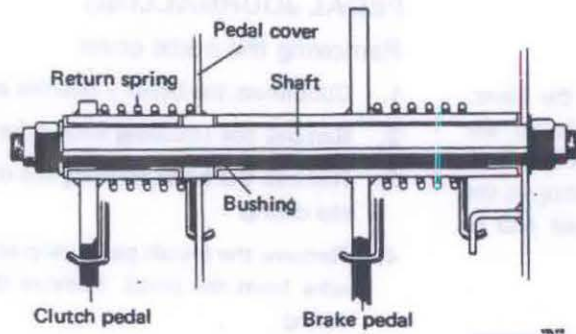


Fig. 52-32. Pedal jounalling

Installing the pedal casing

1. Fit the pedal casing in position. Install the push rod in the master cylinder and tighten up the pedal casing.
2. Fit the bolts and tighten up the master cylinder.
3. Fit the clutch wire on the casing and pedal. Adjust the stop bolt.
4. Connect the electric cables to the contact for the stop lights and the contact for the brake pedal travel.
5. Connect up the battery positive cable.

WARNING VALVE

Each time the valve is in the warning position, it should be re-set to normal position after the fault has been put right. If this is not done, the piston and guide pin can be damaged.

Re-setting to normal position.

1. Disconnect the electric cable and unscrew the contact so that the pistons return to normal position, Fig. 52-33.
2. Clean and bleed the faulty hydraulic circuit.

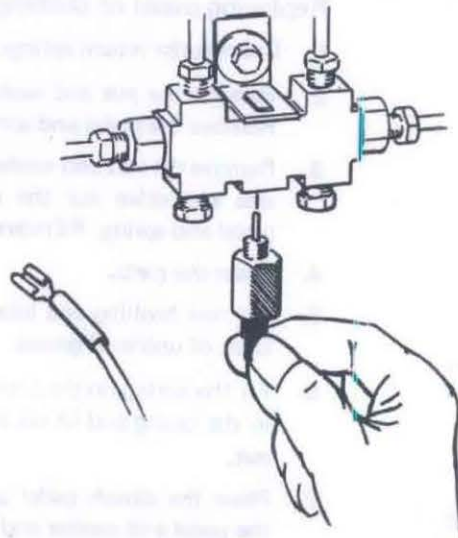


Fig. 52-33. Removing the contact

3. Carefully screw in the contact about 15 Nm (1.5 kpm = 11 lbftf). Connect up the electric cable.

Replacing the warning valve

Clean the outside of the valve. Remove the retaining bolts and the valve. Install the new valve. Fig. 52-34 shows the various connections. Bleed the brake system.

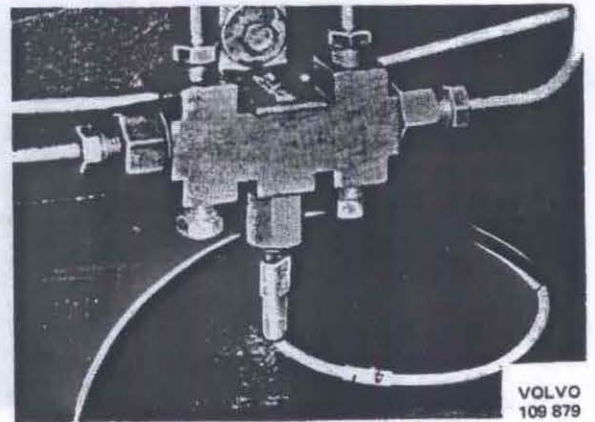


Fig. 52-34. Warning valve

CONTACT FOR STOP LIGHTS

Adjusting the position

For proper function and in order not to damage, the contact should have a certain location in relation to the pedal. The distance between the pedal in rest position and the brass sleeve on the contact should be 2-6 mm (0.08-0.24"), see Fig. 52-35. If the distance is otherwise, slacken the nuts and move the contact so that the correct gap is obtained. Then re-tighten the nuts.

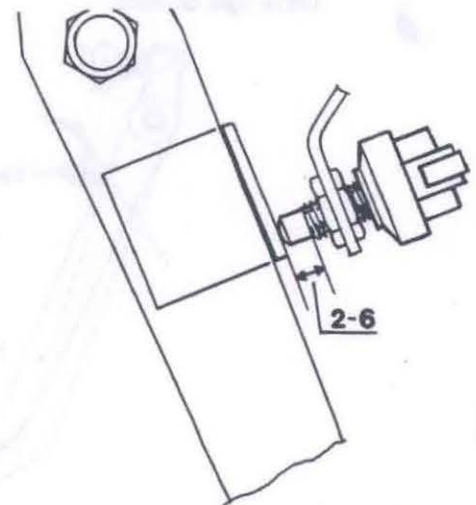


Fig. 52-35. Gap measurement

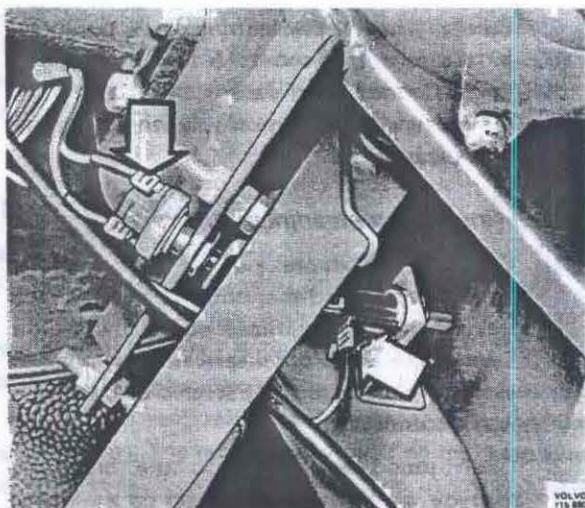


Fig. 52-36. Contact for stop lights and pedal travel

HYDRAULIC SYSTEM

Bleeding

Special tool: 6126 Bleeder spanner



Fig. 52-38. Bleeder spanner

CONTACT FOR BRAKE PEDAL TRAVEL

Adjusting the position

The contact should give a warning when there remains 90–100 mm (3.5–4.0") of the pedal travel, measured at the centre of the footplate. Since this normally can be checked only when bleeding, the position of the contact can be checked instead by measuring the distance with the pedal at rest position between the pedal bracket and the contact terminal, see Fig. 52-37. This gap should be 15–17 mm (0.60–0.67"). If the gap is otherwise, slacken the nut and move the contact bracket so that the right gap is obtained. Then re-tighten the nut.

To re-set from the warning position, press back the contact terminal to the rest position.

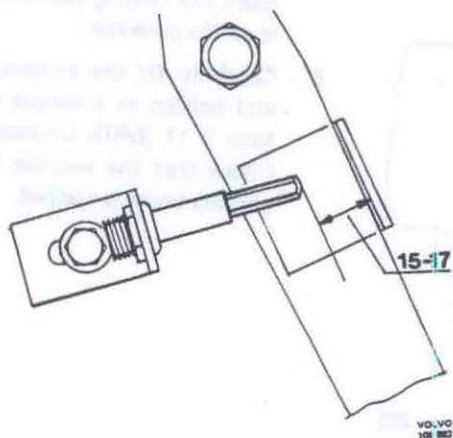


Fig. 52-37. Adjustment measurement

If no resistance is felt when depressing the brake pedal or if it feels spongy then there must be air in the system.

As soon as any part in the system has been removed, the system must be bled. Air can also get into the system due to the fact that too little brake fluid is in the reservoir. If, for example, only one wheel cylinder has been removed and an insignificant amount of brake fluid ran out, it is generally necessary to bleed only the cylinder. Otherwise the entire system must be bled.

With bleeding or similar work, brake fluid must not be allowed to run onto the friction surfaces or linings. Do not allow the brake fluid to spill onto the paintwork since this can damage the paintwork.

When topping up with brake fluid the following should be observed. The brake fluid must meet the requirements according to the standard SAE J 1703, for example, Brake Fluid 430.

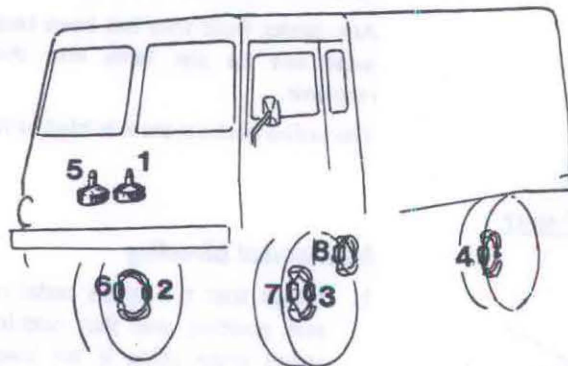
Any brake fluid that has been bled from the system must not be put back into the bleeder unit or reservoir.

The entire brake system is bled as follows:

Mechanical bleeding

1. Check that the brake pedal returns fully to the rest position and that nothing prevents its full travel when using it for bleeding. Depress the brake pedal several times in order to even out any vacuum in the servo unit and in this way disconnect it.

2. Clean round the cap on the brake reservoir and round the contact on the warning valve. Remove the contact, see Fig. 52-34. If necessary top up with brake fluid. Blow clean the cap venting hole.
3. For bleeding a plastic hose is required which can be pressed onto and connected tight round the bleeder nipple. The lower end of the hose should be provided with a glass or plastic tube. Also required is a glass bottle provided with so much brake fluid that the opening of the tube can be kept under the surface in order to prevent air from being sucked in. To turn the nipple, use a 7/16" ring spanner for the servo unit and bleeder tool 6126 for the other points. New brake fluid must be available so that the reservoir can gradually be filled. The level must not be too low otherwise air can penetrate into the system via the reservoir.
4. Bleeding should be done in the order shown in Fig. 52-39 and as follows:
Remove the protective cap and fit the ring spanner and plastic hose on the bleeder nipple. Allow the pipe opening to hang down under the surface of the fluid in the glass bottle. Open the bleeder nipple a maximum half turn. Slowly depress the brake pedal to the floor. When the pedal has reached the floor, wait for a brief moment and then quickly release the brake pedal. Repeat this procedure until brake fluid free from air bubbles flows out. Then depress the brake pedal to the floor and close the bleeder nipple. Re-fit the protective caps on the nipples.
5. Generally it is sufficient to bleed each circuit once. If the pedal can be depressed without any resistance worth mentioning or if it still feels spongy, repeat the bleeding.
6. Fill with brake fluid until the reservoirs are full.



7. Carefully install the warning contact, tightening it to a torque of about 15 Nm (1.5 kpm = 11 lbftf). Connect up the electric cable. Check that the warning lamp goes on only when the parking brake is applied.

Bleeding with a bleeding apparatus

1. Check that the brake pedal goes back fully when released and that nothing prevents its full travel from being utilized during the bleeding. Depress the brake pedal several times in order to even out any vacuum in the servo unit and in this way disconnect it.
2. Clean round the cover on the brake fluid reservoir and round the contact on the warning valve. Remove the contact, see Fig. 52-33. If necessary fill with brake fluid.
3. Connect the bleeder apparatus, to the right reservoir, according to the instructions of the manufacturer. Working pressure is 0.2 MPa (2 kp/cm² = 30 lbf/in²).
4. Fit the plastic hose on the upper servo unit nipple and allow the other end of the hose to hang down in a collecting vessel. Open the bleeder nipple with a 7/16" ring spanner but a maximum half turn. Pump several times with the brake pedal. Close the nipple when brake fluid free from air bubbles flows out. Continue the bleeding with tool 6126 at wheel cylinders 2, 3 and 4, see Fig. 52-39.
5. Transfer the bleeder apparatus to the left reservoir and repeat the bleeding as above through nipples 5, 6, 7 and 8, see Fig. 52-39.
6. Generally it is sufficient to bleed each circuit once. If the brake pedal can still be depressed without any resistance worth mentioning or if it feels spongy repeat the bleeding.
7. After the bleeding has been completed, make the apparatus pressureless and unscrew the cap. Blow clean the venting hole in the standard cap and fit it on the reservoir.
8. Carefully fit the contact on the warning valve and tighten to a torque of approx. 15 Nm (1.5 kpm = 11 lbftf). Connect up the electric cable. Check that the warning lamp goes on when the parking brake is applied.

Fig. 52-39. Bleeding sequence

GROUP 54 AUXILIARY BRAKE

Description

SERVO UNITS

The function of the servo units is to boost the brake pressure so that less brake pedal force is required when braking. They function as follows:

When the brake system is at rest position (see Fig. 54-1), the vent valve for the control units is closed by a spring. The vacuum valve fixed on the same shaft has a certain position at this time. Another spring presses down the diaphragm with the vacuum valve

seat and the control piston. The vacuum valve is, therefore, open and the space to the left of the vacuum piston is connected via the control unit to the space on the right-hand side of the piston. In other words, the same vacuum, is on both sides of the vacuum piston, which the return spring holds pressed to the right, see Fig. below. The pressure piston centre is off-load so that there is an open connection between the master cylinder and wheel cylinder.

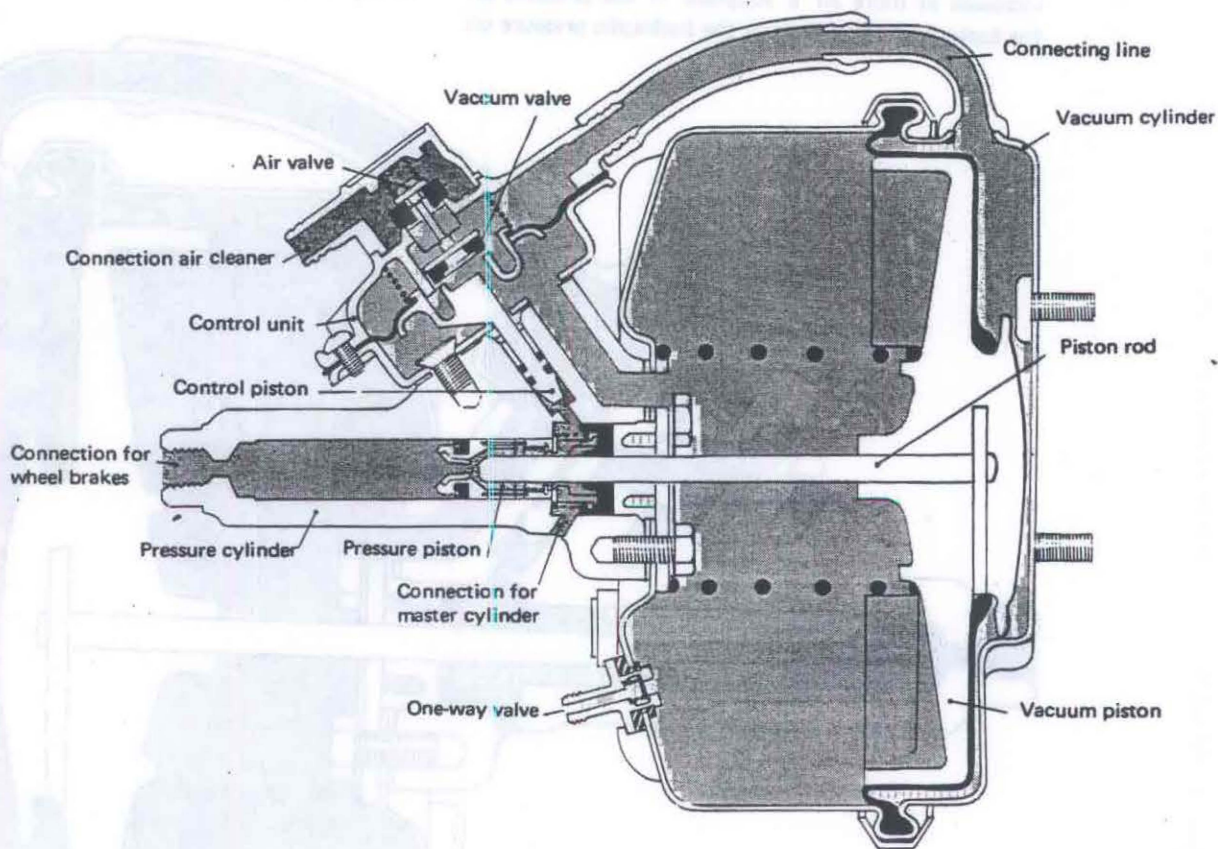
VOLVO
109 554

Fig. 54-1. Servo unit, rest position

When the brake pedal is depressed, the brake fluid is forced under pressure from the master cylinder through the servo unit discharge piston to the wheel cylinders and the brake is applied. When the hydraulic pressure rises under the control piston, the piston and the vacuum valve seat are pressed upwards. This closes the vacuum valve, and with the continued movement upwards the inner, minor section of the vent valve opens first and then the outer, larger section. Atmospheric pressure air flows past the air valve through the connection line to the space to the right of the vacuum piston. Since there is a vacuum on the left-hand side of the piston, the piston is pressed to the left and the piston rod pushes on the thrust piston. At the same time the piston rod closes the connection through the pressure piston centre. In this way, the outgoing hydraulic pressure for the wheel cylinders will be greater than the input pressure for the servo unit, compare Fig. 54-2.

In the control unit the pressure above the diaphragm increases as more air is supplied. If the pressure on the brake pedal and thereby the hydraulic pressure on

the control piston is unchanged, this is finally overcome so that the diaphragm is pressed downwards and the air valve closes. The pressure to the right of the vacuum piston remains unchanged and is unable to overcome the pressure in the pressure cylinder. The moving parts of the servo unit remains therefore in this position and the braking remains constant as long as the same force is exerted on the brake pedal; compare Fig. 54-3.

If the brake pedal is released, the inlet pressure on the control piston reduces and the diaphragm is pressed downwards so that the vacuum valve is exposed. This results in the spaces on both sides of the vacuum piston coming into contact with each other so that the pressure reaches an equilibrium and the piston is pushed to the right. The piston in the pressure cylinder is pushed back to the initial position. Since the piston rod is pulled back further by the vacuum piston, this exposes the centre of the pressure piston so that the brakes are released and all parts return to rest position.

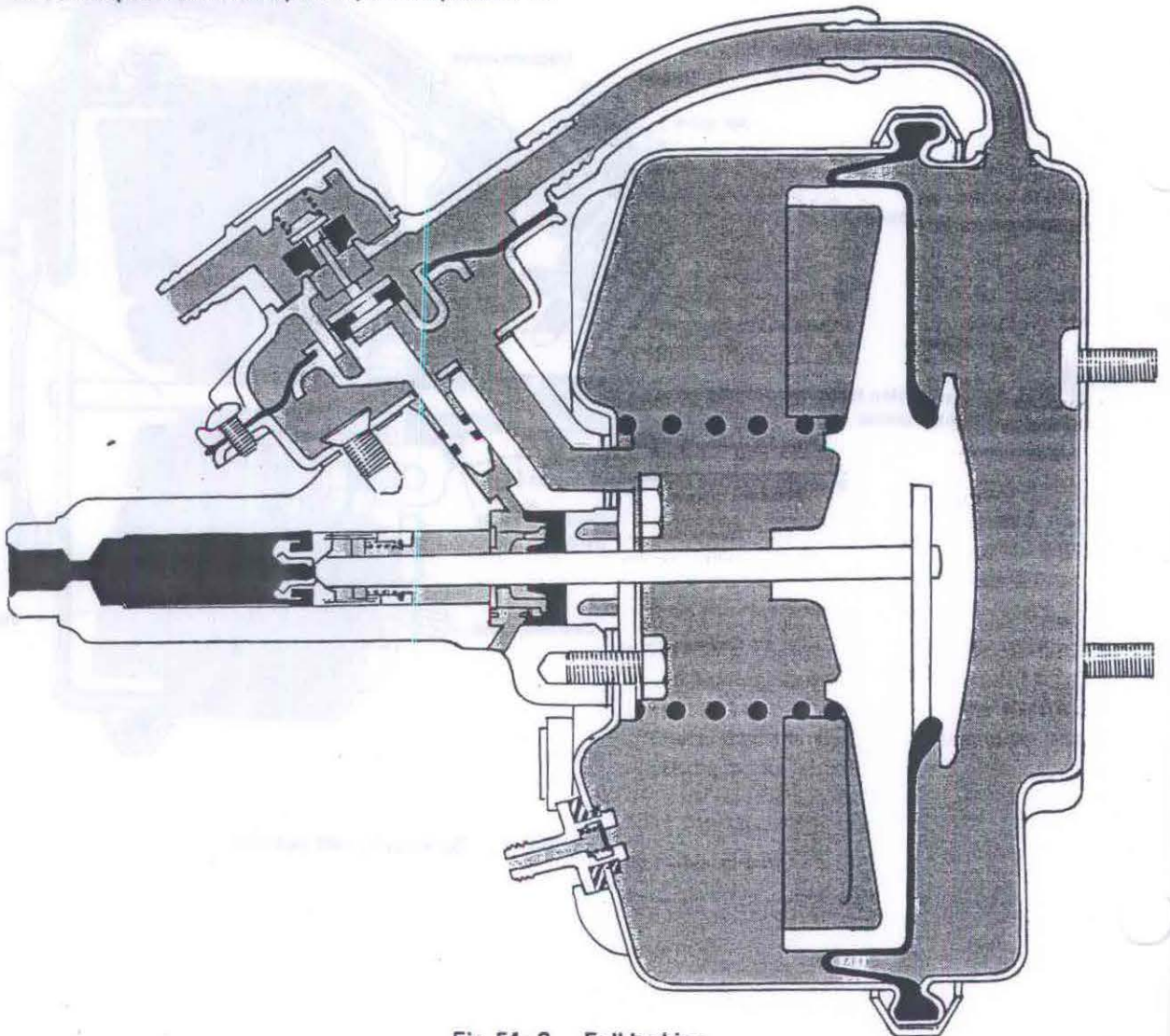


Fig. 54-2. Full braking

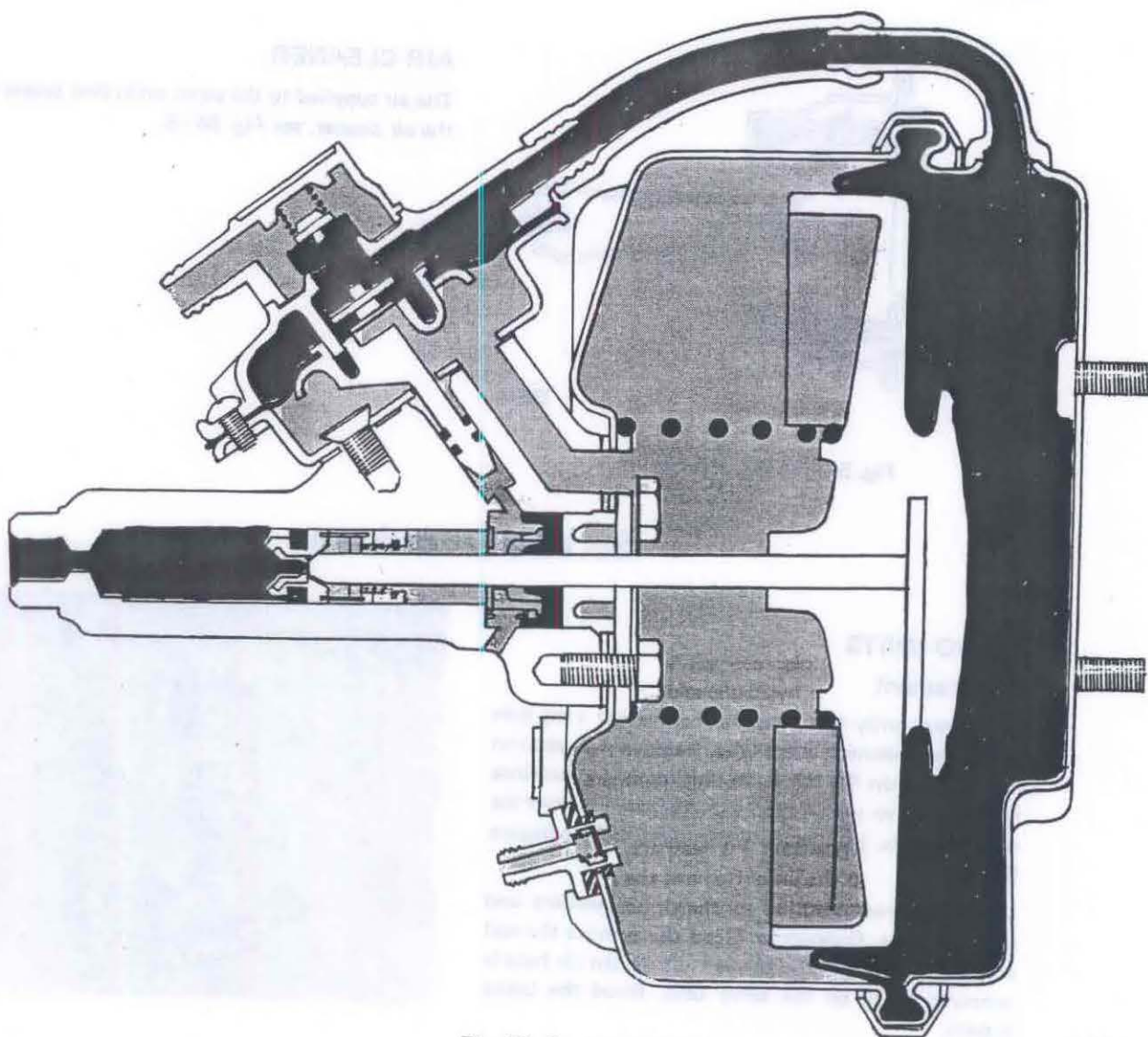


Fig. 54-3. Partial braking

VOLVO
109 886

ONE-WAY VALVE

The one-way valves are placed on the servo units and are connected to the lines from the engine intake manifold. Their function is to prevent air flowing back to the servo units. The valve opens only when the vacuum in the intake manifold is greater than that in a servo unit.

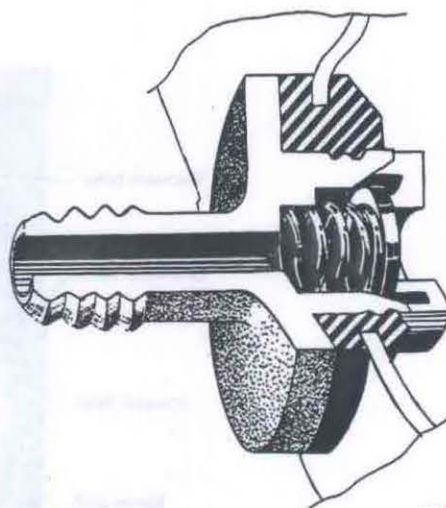
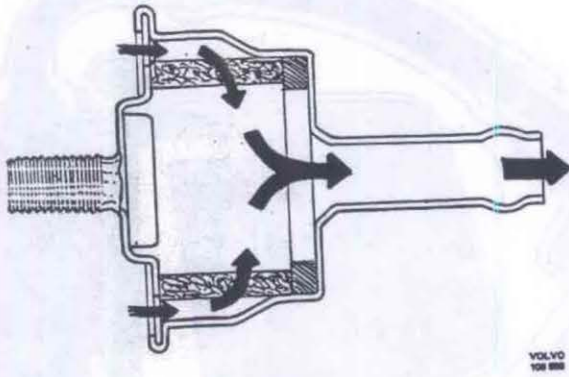
VOLVO
109 887

Fig. 54-4. One-way valve on servo unit



AIR CLEANER

The air supplied to the servo units first passes through the air cleaner, see Fig. 54-5.

Fig. 54-5. Air cleaner

Service Procedures

SERVO UNITS

Replacement

Plug temporarily the brake fluid reservoir vent hole with plastic cement. Clean the hydraulic and vacuum connections on the inside. Disconnect all connections from the servo unit. Plug the brake lines. Remove the retaining nuts. Lift forwards the servo unit, compare Fig. 54-7.

Install the new unit in position. Fit washers and retaining nuts. Connect up the lines. Remove the seal and make sure that the connection for the air hose is properly fitted on the servo unit. Bleed the brake system.

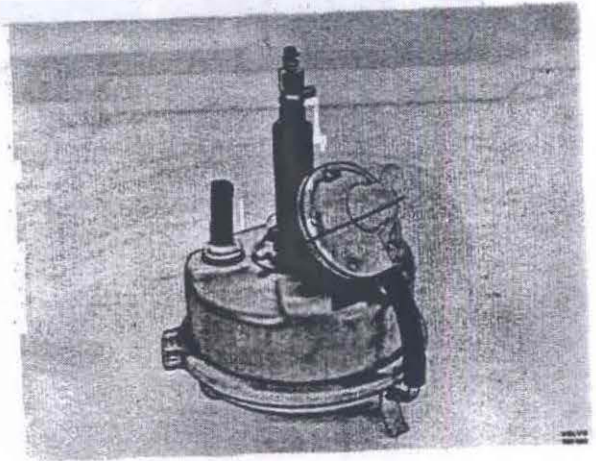


Fig. 54-7. Servo unit removed

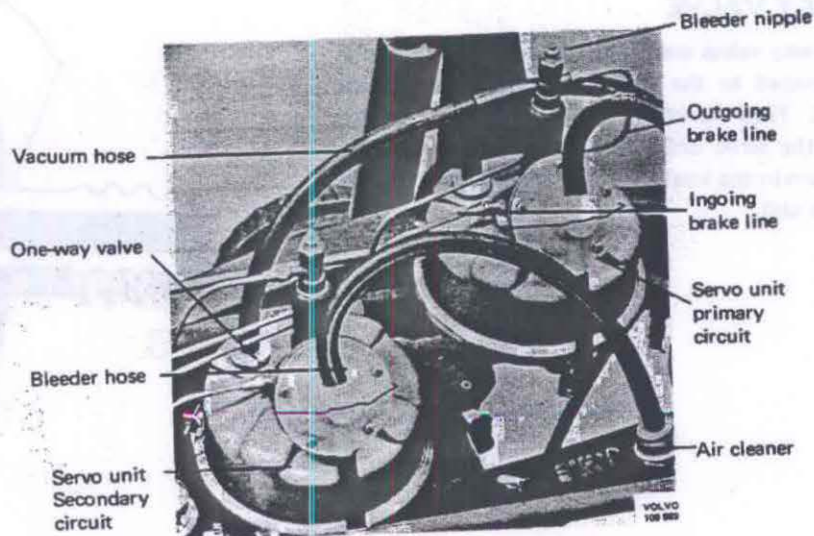


Fig. 54-6. Auxiliary brake components

ONE-WAY VALVE

Replacement (unit removed)

Lever the vacuum hose off the one-way valve. Lever out the one-way valve with the help of two screwdrivers. Remove the seal.

Fit a new seal and check that its flange is fitted properly in position on the servo unit, see Fig. 54-4. Coat the inside of the seal with brake paste and carefully press it into the one-way valve. Make sure that the seal remains properly in the correct position.

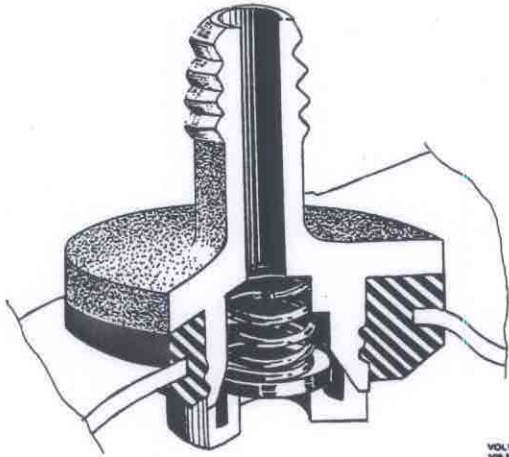


Fig. 54-8. One-way valve

AIR CLEANER

The air cleaner is accessible under the engine cover, see Fig. 54-8. With replacement, remove the rubber hose and the retaining nut, after which the air cleaner can be removed.

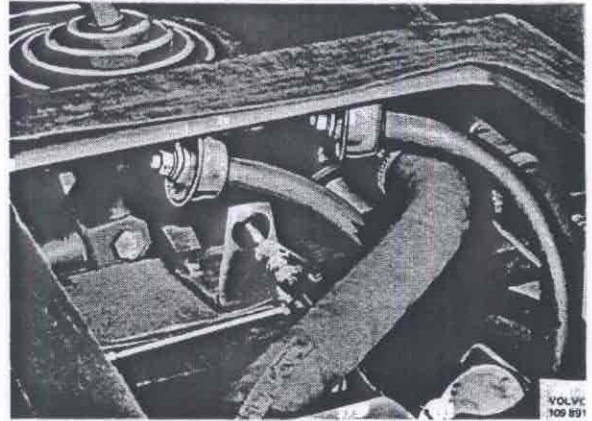


Fig. 54-9. Air cleaner

AIR CLEANER

The air cleaner is designed to filter the air entering the engine. It consists of a cylindrical housing with a pleated filter element inside. The filter element is made of a special paper that traps the dust and dirt particles.

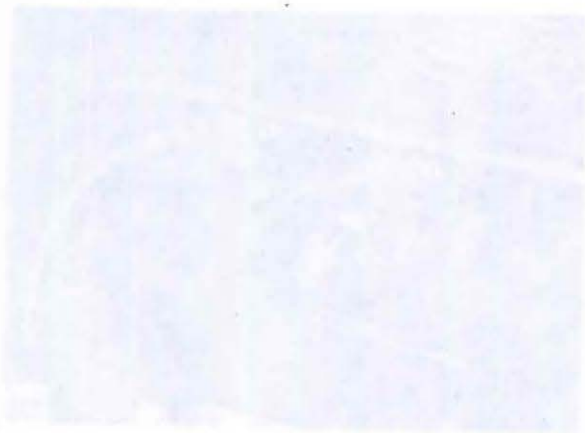


Fig. 1-10 Air Cleaner

ONE-WAY VALVE

The one-way valve is used to allow the flow of air in one direction only.

It consists of a cylindrical housing with a flap inside. The flap is made of a special material that allows the air to flow in one direction but prevents it from flowing back.

The one-way valve is used in many places in the engine, such as in the intake manifold and the exhaust manifold. It is also used in the carburetor to prevent the fuel from flowing back into the intake manifold.



Fig. 1-11 One-Way Valve

GROUP 55 PARKING BRAKE

Description

The parking brake design can be seen from Figs. 55-1 and 55-2.

The parking brake lever is located on the right-hand side of the driver's seat. Applying the parking brake lever actuates the cable so that it applies the propeller

shaft brake located on the gearbox. There the levers press out the brake shoes against the brake drum. The brake linings are bonded.

The parking brake is adjusted with the adjuster mechanism in the propeller-shaft brake.

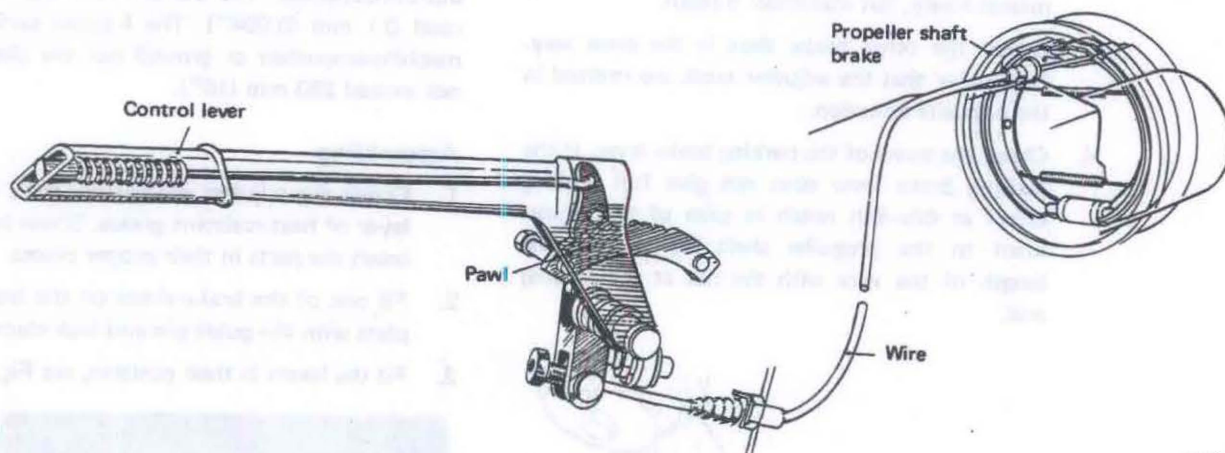


Fig. 55-1. Parking brake

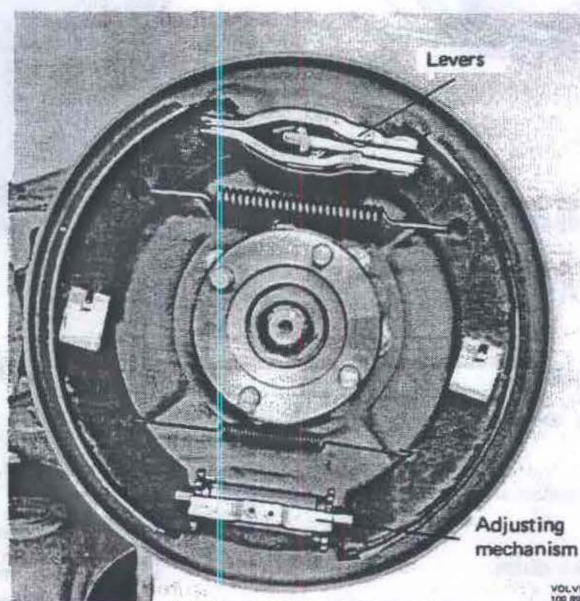


Fig. 55-2. Propeller shaft brake

Service Procedures

GENERAL

Adjusting the parking brake

The parking brake lever should give full parking brake effect at the 4th–5th notch. If it does not do this, adjust the parking brake lever as follows:

1. Jack up the rear end. Check that the parking brake lever is in its forward position and the gears and in neutral.
2. Adjust out one of the brake shoes with a suitable adjuster tool (curved screwdriver), see Fig. 55–3, until the brake drum can be just about rotated. Then slacken the adjuster screw until the drum rotates freely, but maximum 5 teeth.
3. Adjust the other brake shoe in the same way. Remember that the adjuster teeth are rotated in the opposite direction.
4. Check the travel of the parking brake lever. If the parking brake lever does not give full braking effect at 4th–5th notch in spite of the adjustment to the propeller shaft brake, alter the length of the wire with the nut at the leading end.

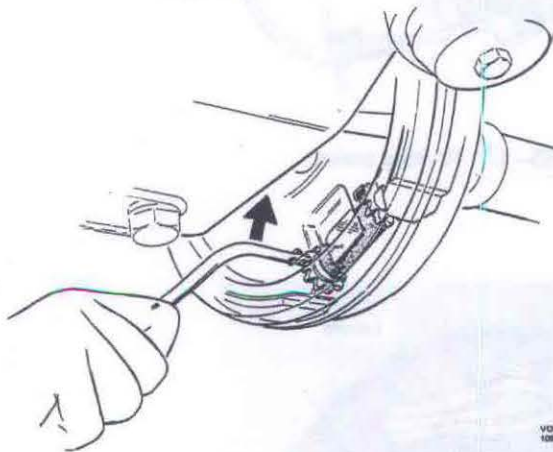


Fig. 55–3. Adjusting the parking brake

PROPELLER SHAFT BRAKE

Dismantling

1. Jack up the vehicle.
2. Disconnect the exhaust pipe on the left-hand side.
3. Remove the propeller shaft flange from the brake drum.
4. Pull off the brake drum.
5. Remove the lock clamps and guide pins.
6. Remove the brake shoes.
7. Remove the levers and adjuster screws.

Checking and replacing parts

Clean the parts before checking.

If the brake linings are oily, damaged or worn so that there is not more than 1.5 mm (1/16") left of the lining thickness, replace the shoes complete.

Check that the adjuster mechanism nut screws easily into the housing. If the housing or pawls are damaged, replace the brake backing plate. The flange is thereby removed when doing this, so see under the heading "Dismantling the distribution gearbox", Group 43.

Check the friction surface of the brake drum and its out-of-roundness. The out-of-roundness may not exceed 0.1 mm (0.004"). The friction surface can be machine-smoothed or ground but the diameter may not exceed 253 mm (10").

Assembling

1. Grease the adjuster mechanism parts with a light layer of heat-resistant grease. Screw together and insert the parts in their proper places.
2. Fit one of the brake shoes on the brake backing plate with the guide pin and lock clamp.
3. Fit the levers in their position, see Fig. 55–4.

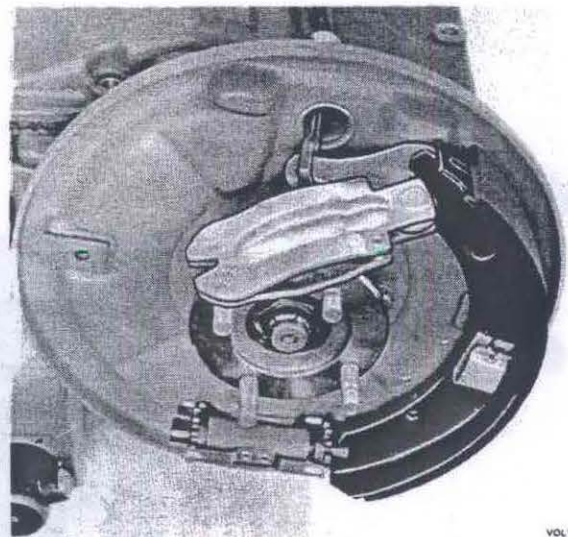


Fig. 55–4. Levers

4. Hook on the upper, stronger return spring on the brake shoes. Tension out the shoes in their location. Fit the guide pin and lock clamp.
5. Fit the lower return spring.
6. Fit the brake drum and propeller shaft. Tighten up the nuts.
7. Adjust the propeller shaft brake.
8. Fit the exhaust pipe.

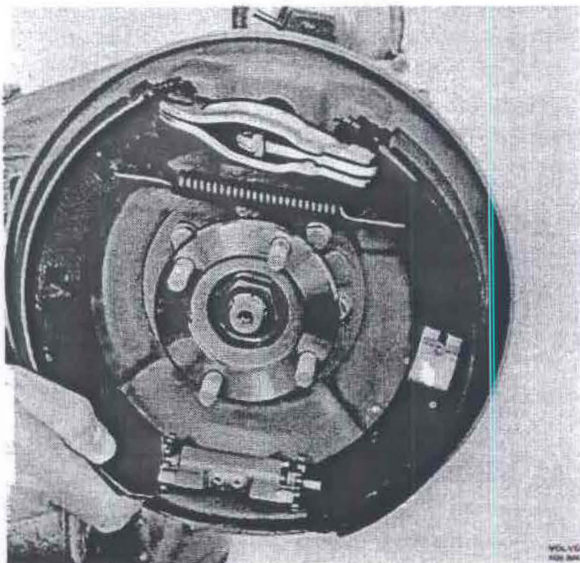


Fig. 55-5. Fitting the brake shoes

CONTROL MECHANISM

Replacing parking brake lever or ratchet components

1. Remove the clamp bolt and lever from the parking brake lever shaft.
2. Remove nuts and washers from the pawl segment attachment.
3. Pull forward the parking brake lever complete.
4. Remove the button and take the spring out of the parking brake lever. Drill out the rivet and remove the push rod and pawl.
5. Replace both bushings in the parking brake lever journalling. Coat them with a light layer of universal grease.
6. Fit the new parts in reverse order to removal, see Fig. 00. Make sure that the rivet is properly fitted without preventing the movement of the pawl.

7. When installing the parking brake lever, check the warning function of the contact. The lever should be placed so that the lamp lights at the 2nd-3rd notch.
8. Check the function and if necessary adjust the parking brake.

WIRE

Replacement

1. Jack up the vehicle.
2. Remove the adjuster nut from the front end of the wire.
3. Remove the lock washer at the wire front attachment.
4. Remove the rear propeller shaft section.
5. Disconnect the exhaust pipe on the left-hand side.
6. Remove the brake drum.
7. Unhook the wire from the lever on the propeller shaft brake.
8. Hook on the new wire on the lever on the propeller shaft brake.
9. Fit the brake drum and the propeller shaft. Tighten up the nuts.
10. Adjust the propeller shaft brake.
11. Fit the exhaust pipe.
12. Tighten the adjuster nut until full braking effect is obtained at the 4th-5th notch with properly adjusted propeller shaft brake.

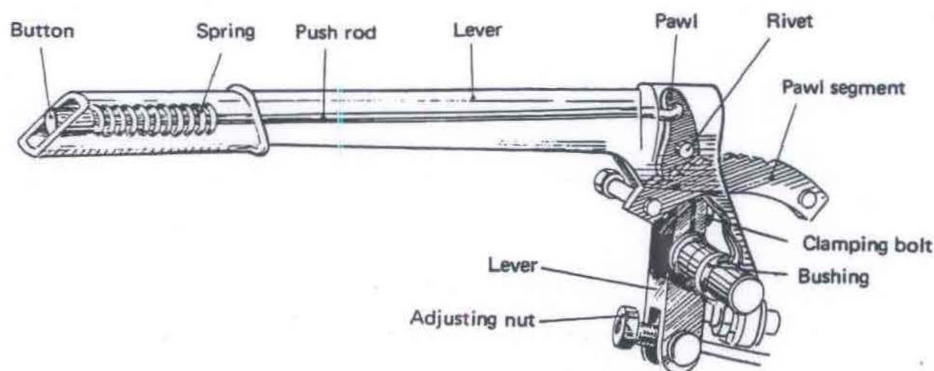
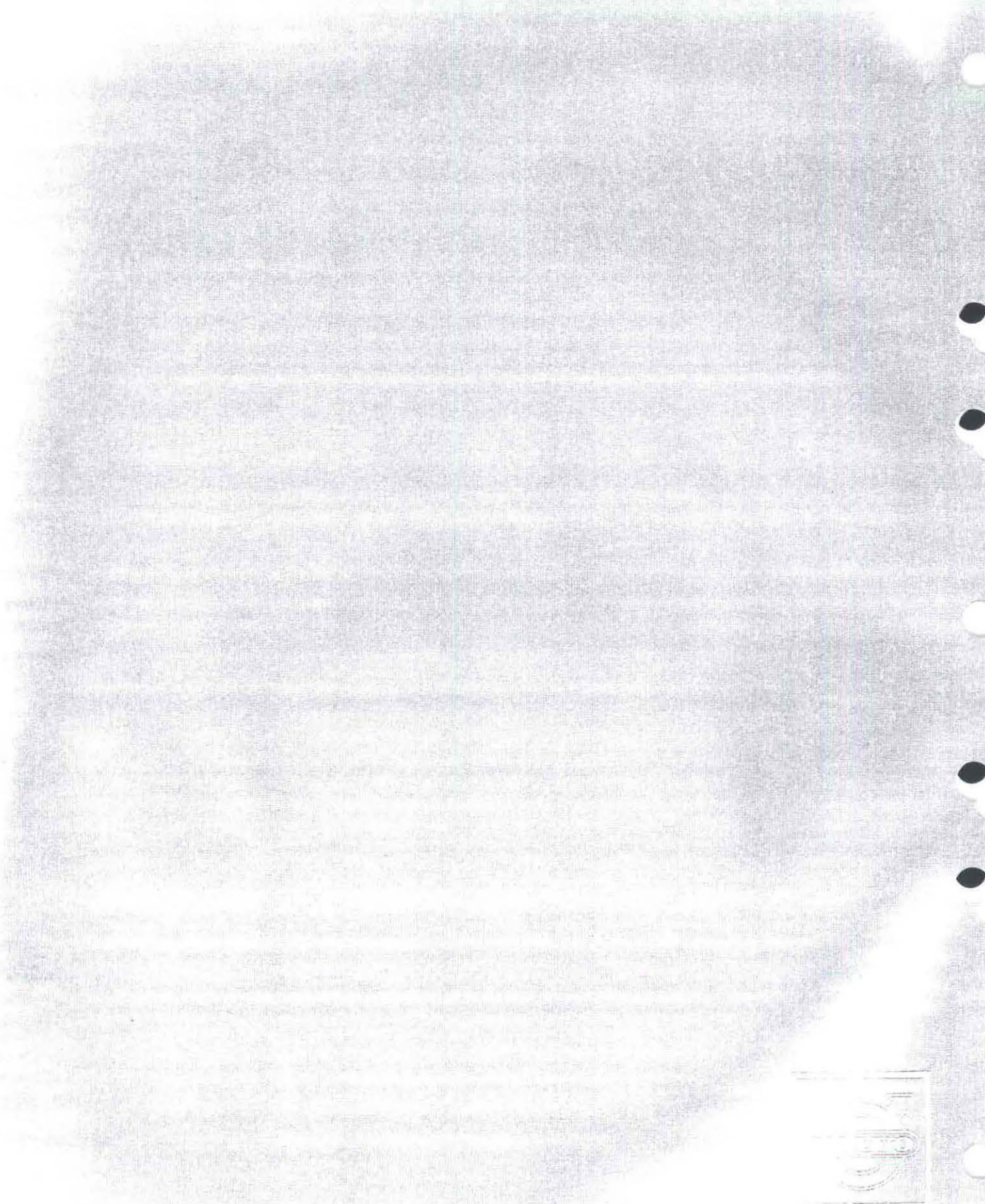


Fig. 55-6. Parking brake lever assembly



TP 11079/1
Engelska
2.500. 2.75.
Printed in Sweden