

SERVICE MANUAL

TRUCKS

L 385

Export Service Department

AKTIEBOLAGET

VOLVO

GÖTEBORG, SWEDEN

PART 4

PROPELLER SHAFT

DESCRIPTION

L 38503 (early production), L 38505 and L 38507 trucks are fitted with divided propeller shafts (Fig. 4-1). The rear end of the forward section is suspended in a bearing. The rear section is fitted with a slip joint to cushion rear axle movements.

L 38503 (late production) trucks have undivided propeller shafts.

Hardy-Spicer universal joints are used. These consist of a joint cross journalled in needle bearings both in the propeller shaft yoke and in the flange yoke.

The center bearing (Fig. 4-2) consists of two tapered roller bearings (15) in a cage (12). For the adjustment of the bearing, there is a spacer ring (14) and shims (13). The cage with the outer rings, the cover (4) with the felt rings (3) and the rubber ring (7) are bolted together into one unit by means of the bolts (5) and attached to the bracket ring (6).

REPAIR INSTRUCTIONS

REMOVING THE PROPELLER SHAFT

1. Loosen the bolts (12, Fig. 4-1) holding the front and rear sections of the propeller shaft together.
2. Loosen the bolts (9) in the companion flange on the rear axle and lift out the rear section of the propeller shaft.
3. Loosen the nuts (1) in the flange at the transmission.
4. Loosen the bolts for the center bearing and lower the propeller shaft and center bearing.

DISASSEMBLING THE PROPELLER SHAFT

Before the rear section of the propeller shaft is separated at the slip joint, the yoke sleeve (10) and the propeller shaft are marked with a punch as shown in Fig. 4-3. The nut (d, Fig. 4-4) is then loosened and the yoke sleeve is pulled off.

DISASSEMBLING THE UNIVERSAL JOINTS

1. Remove the lock rings (Fig. 4-5) retaining the needle bearings in the yokes. Remove the lubricating nipple from the joint cross.

2. Use a hammer and a metal drift to force the joint cross as far as it will go in one direction as shown in Fig. 4-6. The needle bearing will come out about half-way.
3. Then drive the joint cross as far as it will go in the opposite direction.
4. Drive out one of the needle bearings with a thin metal drift (Fig. 4-7). Take out the joint cross. Drive out the other needle bearing.
5. Dismantle the other yoke in a similar way.

DISASSEMBLING THE CENTER BEARING

1. Bend up the lock tab and remove the nut (10, Fig. 4-2). Then remove the washer (9).
2. Mark the flange (8) and the shaft as shown in Fig. 4-8. Pull off the flange by using a puller.
3. Remove the bolts (5) holding the center bearing together. Then remove the bracket ring.
4. Remove the rear cover (4) and the rubber ring. Pull out the bearing and the forward cover with a puller. See Fig. 4-9.
5. If necessary, the outer rings are driven out of the sleeve by using a hammer and a copper drift.
6. Remove the felt ring if required with the help of a pointed tool. See Fig. 4-10.

INSPECTING THE PROPELLER SHAFT

Before carrying out inspection, clean all parts thoroughly with kerosene or white spirit. Examine all parts for wear, deformation or other damage. Place the propeller shaft sections in V-supports and check alignment. (Fig. 4-11). If they are not straight to within 0.5 mm (3/64"), they must be replaced.

The splines on the slip joint must be examined for wear. If they are worn, the sleeve or even the complete propeller shaft must be replaced.

INSPECTING THE UNIVERSAL JOINTS

Joint crosses and needle bearings must be examined for looseness and marks on the bearing races. If there are any signs of defects or other damage, then the joint cross complete with needle bearings must be replaced.

Examine the needle bearing housings for looseness in the yokes. Replace the yokes if there is looseness. If there should be looseness in the needle bearing housing which is welded to the propeller shaft, the complete propeller shaft must be replaced.

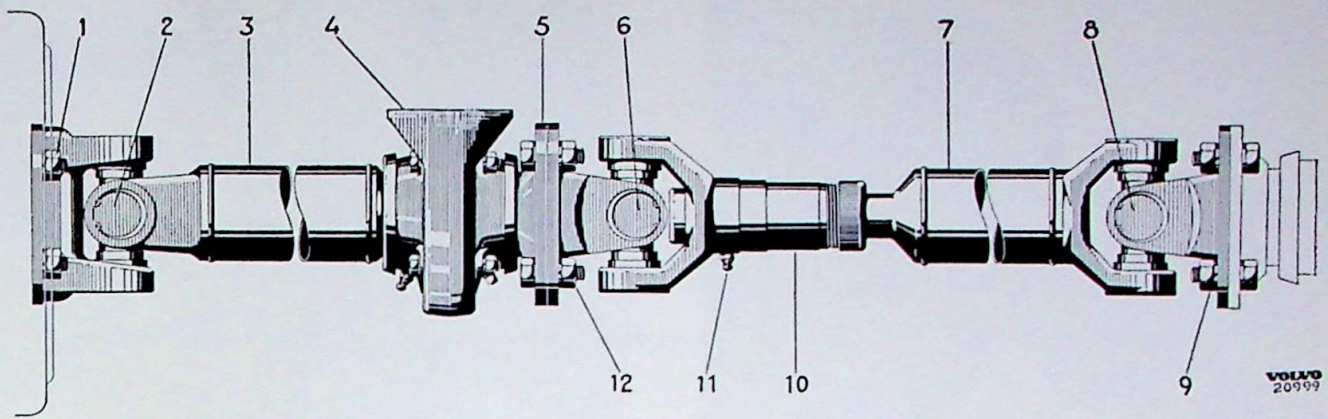

Fig. 4-1. Propeller shaft.

- | | | |
|-------------------------------------|----------------------------------|------------------------|
| 1. Nut | 5. Companion flange | 9. Bolt |
| 2. Forward universal joint | 6. Central universal joint | 10. Yoke sleeve |
| 3. Forward section, propeller shaft | 7. Rear section, propeller shaft | 11. Lubricating nipple |
| 4. Center bearing | 8. Rear universal joint | 12. Bolt |

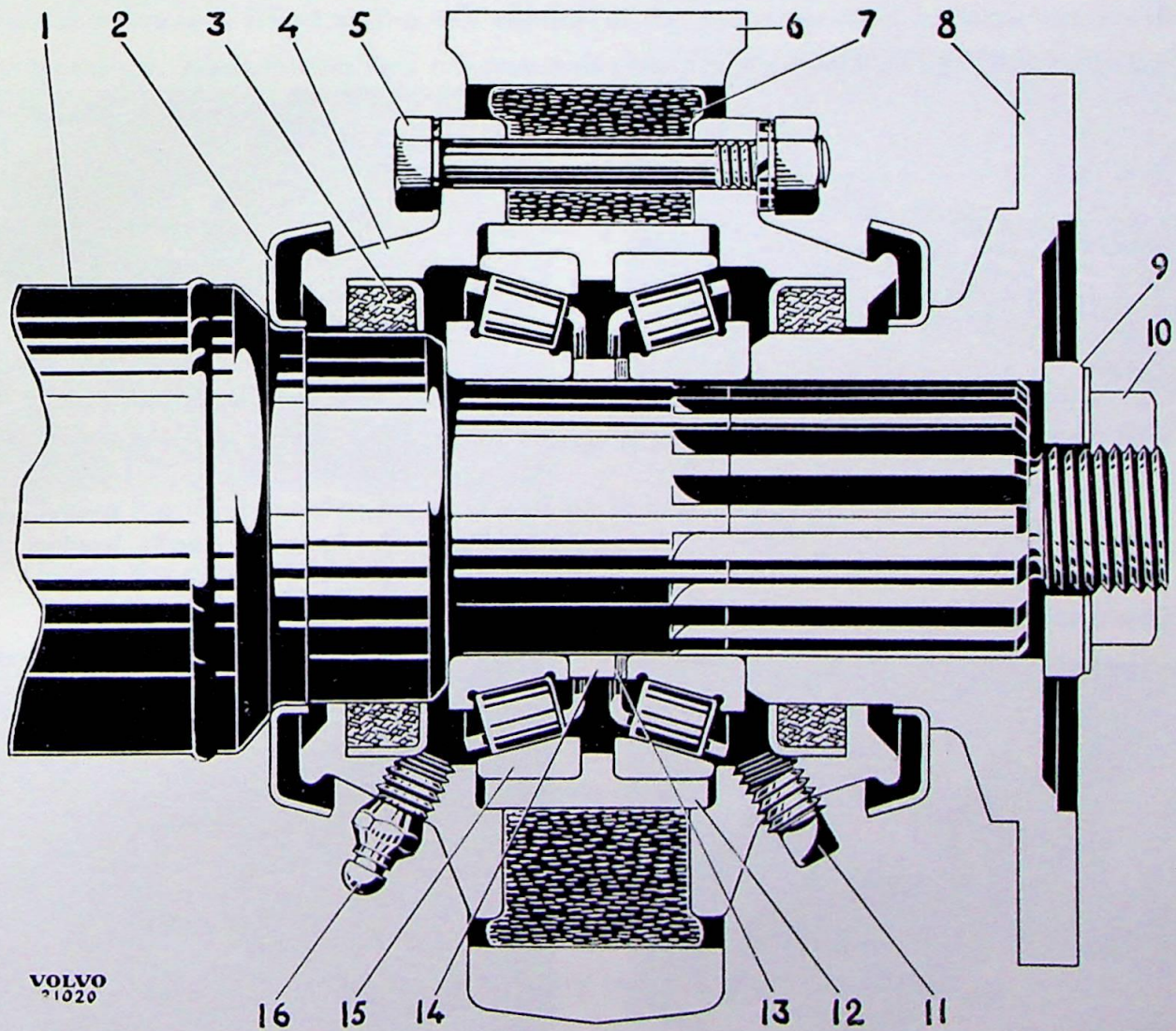

Fig. 4-2. Center bearing.

- | | | |
|-------------------------------------|---------------------|------------------------|
| 1. Forward section, propeller shaft | 7. Rubber ring | 13. Shims |
| 2. Dust slinger | 8. Companion flange | 14. Spacer ring |
| 3. Felt ring | 9. Thrust washer | 15. Roller bearing |
| 4. Cover | 10. Nut | 16. Lubricating nipple |
| 5. Bolt | 11. Plug | |
| 6. Bracket ring | 12. Cage | |

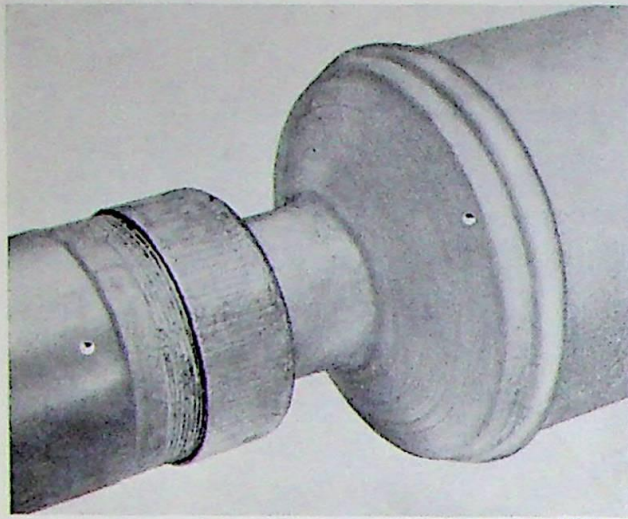

Fig. 4—3. Marking of propeller shaft and yoke sleeve.

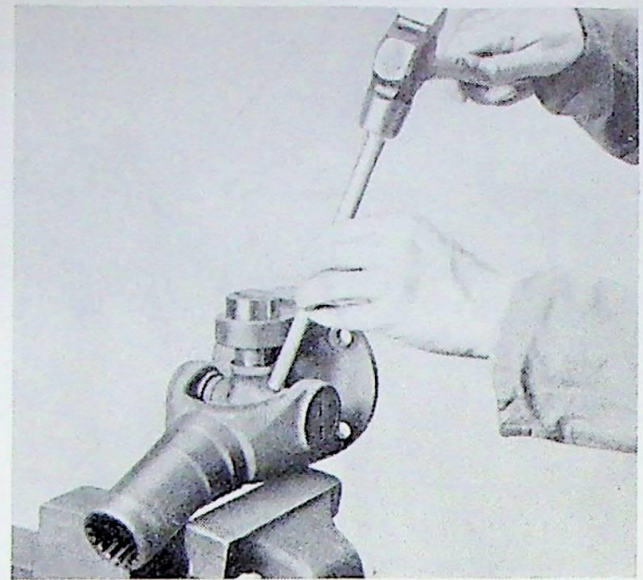

Fig. 4—6. Disassembling joint cross.

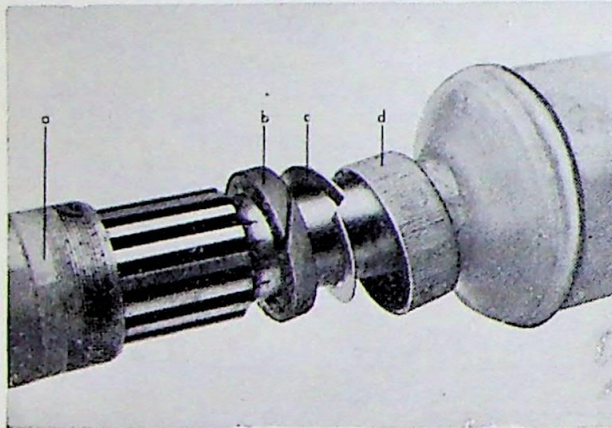

Fig. 4—4. Slip joint.

- a. Yoke sleeve
- b. Cork gasket
- c. Washer
- d. Nut

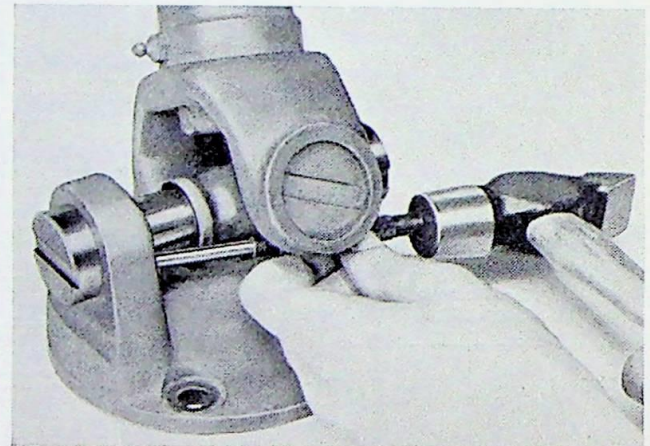

Fig. 4—7. Removing needle bearing.

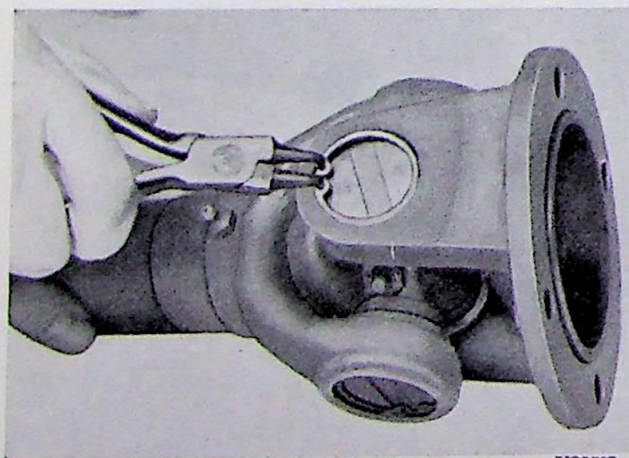

Fig. 4—5. Removing lock ring.

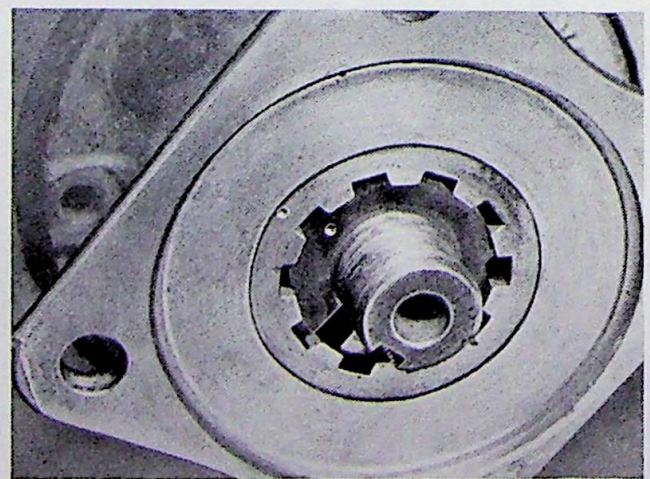

Fig. 4—8. Markings on shaft and flange.

INSPECTING THE CENTER BEARING

The tapered roller bearings must be examined for scars, cracks or other damage on the rollers, races or retainers. Replace the bearing if there are signs of damage.

The rubber ring should be undamaged, soft and flexible. It should not be loose in the bracket ring when fitted.

The felt rings in the cover should seal well on the sliding surfaces of the companion flange and the propeller shaft. If they do not seal well, they should be replaced.

ASSEMBLING THE PROPELLER SHAFTS

The yoke sleeve is fitted on the rear section of the propeller shaft in accordance with the markings. When fitting new or unmarked parts, make sure that both the yokes are fitted in the same plane.

After fitting, measure the axial and radial throw of the flange as shown in Figs. 4-12 and 4-13 respectively. The maximum reading shown on the indicator should not exceed 0.1 mm (0.004").

ASSEMBLING THE UNIVERSAL JOINTS

1. Place the joint cross with new washers in one of the yokes. Turn the joint cross so that the lubricating nipple in the center is towards the flange yoke (Fig. 4-14).
2. Move the joint cross as far as it will go in one direction.
3. Place the needle bearing on the free end (Fig. 4-15). Then press in the needle bearing until the lock ring groove is exposed. Use a drift with a diameter somewhat smaller than the needle bearing.
4. Fit the other needle bearing in the same way.
5. Fit the needle bearings in the other arm of the cross in the same way.
6. Fit the lock rings.

ASSEMBLING THE CENTER BEARING

Before assembling the center bearing, carry out the following adjustments first:

1. Press the outer rings into the cage (12, Fig. 4-2).
2. Lay one of the inner rings with the rollers in a press. Fit the cage, spacer ring (14), shims (13) and the other inner ring.

3. Apply a pressure of 2 tons carefully to the upper inner ring. Measure the clearance with a dial indicator as shown in Fig. 4-16. The clearance should be 0.08-0.13 mm (0.0030"-0.0050"). Add or remove shims until this clearance is obtained.

NOTE. Do not twist the cage but try and lift it as vertically as possible.

When the bearing has been correctly adjusted, it should be packed with ball-bearing grease. The center bearing assembly is then assembled in the reverse order to that used when disassembling. Fit the flange in accordance with the markings. When fitting unmarked parts, fit the flange so that the yoke that is to be fitted on the flange lies in the same plane as the yoke on the front section of the propeller shaft. See Fig. 4-1.

FITTING THE PROPELLER SHAFTS

The propeller shafts are fitted in the reverse order to that used when removing. Use new lock washers.

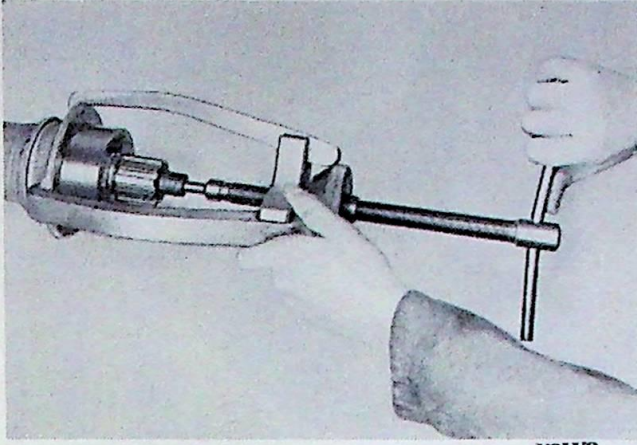

VOLVO
20991

Fig. 4—9. Removing center bearing.

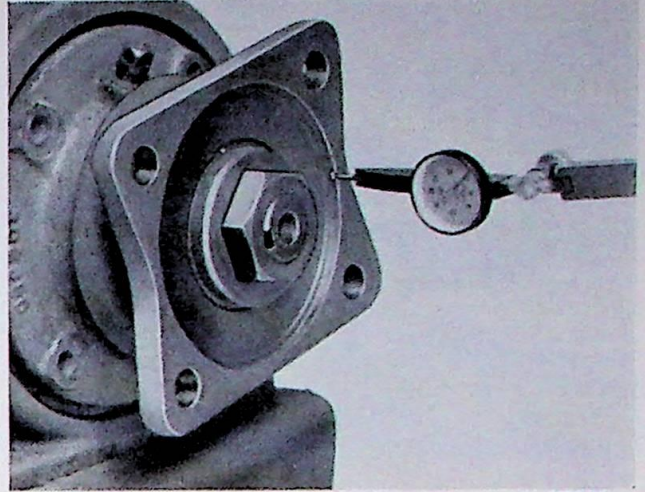

VOLVO
20994

Fig. 4—12. Measuring axial throw of flange.

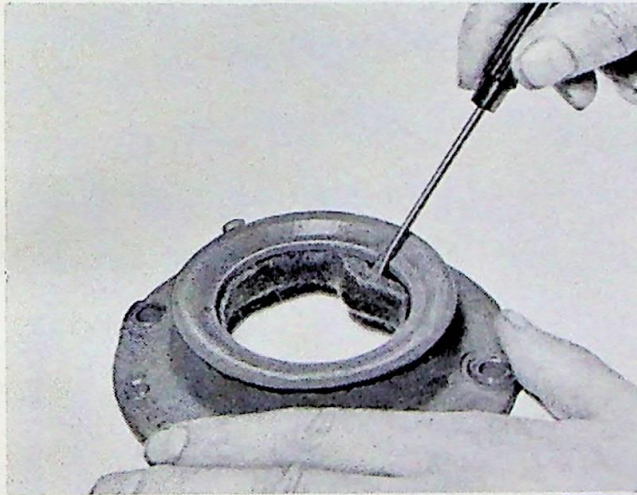

VOLVO
20992

Fig. 4—10. Replacement of seal ring.

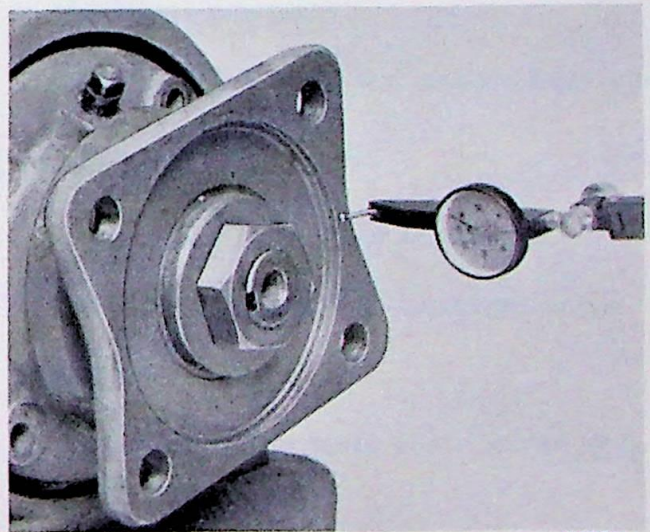

VOLVO
20995

Fig. 4—13. Measuring radial throw of flange.

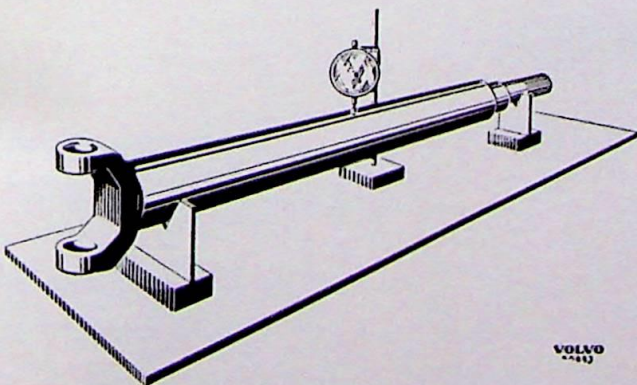

VOLVO
20993

Fig. 4—11. Checking alignment of propeller shaft.

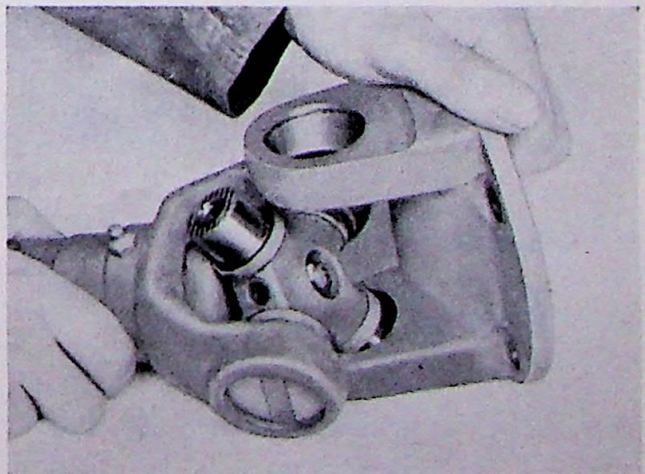

VOLVO
20996

Fig. 4—14. Assembling universal joint.

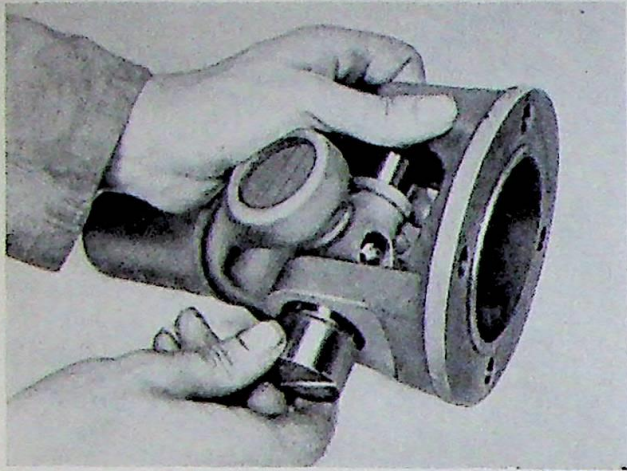

VOLVO
20997

Fig. 4—15. Fitting needle bearing.

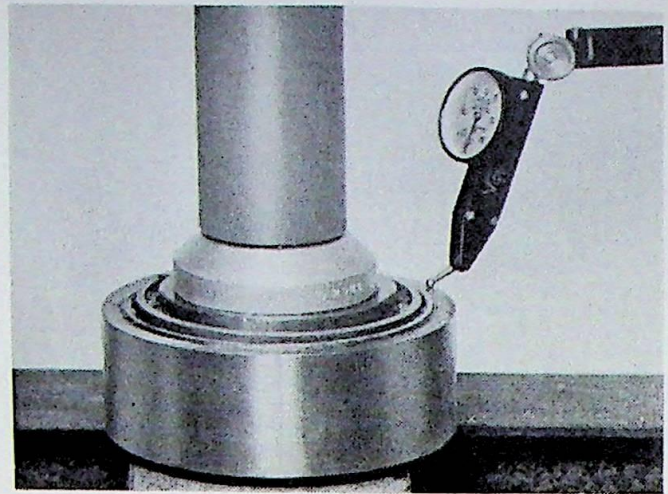

VOLVO
20998

Fig. 4—16. Measuring clearance in center bearing.

FAULT TRACING

FAULT	
POSSIBLE CAUSE	REMEDY
KNOCKING SOUND IN UNIVERSAL JOINTS DURING ACCELERATION OR DECELERATION	
Flange bolts not properly tightened.	Tighten or replace bolts.
Looseness in slip joint.	Replace worn parts.
Looseness in needle bearings.	Replace joint cross and needle bearings.
NOISINESS OR VIBRATIONS FROM PROPELLER SHAFT	
Slip joint dry and chafing.	Lubricate slip joint as instructed.
Looseness or other fault in center bearing.	Examine bearing. Adjust or replace.
Distorted flange.	Replace flange.
Unbalanced propeller shaft.	Replace shaft or have it balanced in a special machine.
Warped propeller shaft.	Replace the warped shaft.

TOOLS

No special tools are required for work on the propeller shaft.

SPECIFICATIONS

Make and type	Hardy-Spicer with needle bearings
Shims for center bearing	0.10 mm (0.0040") and 0.35 mm (0.0140")
Companion flange:	
Permissible warp	max. 0.1 mm (0.0040")
Permissible out-of-roundness	max. 0.1 mm (0.0040")
Lubricant for universal joints	Special chassis lubricant
Lubricant for center bearing	Bearing grease