

# SERVICE MANUAL

TRUCKS

**L 385**

*Export Service Department*

AKTIEBOLAGET

**VOLVO**

GÖTEBORG, SWEDEN

# PART 10

## ELECTRICAL SYSTEM

### DESCRIPTION

L 385 trucks are fitted with a 24-volt, single-pole electrical system. The chassis and the engine serve as ground. The negative battery terminal is connected to the chassis.

The main components on the electrical system consist of the battery, the starter motor, the generator, the charging regulator, the instruments, the lighting system and the horn.

#### BATTERIES

The batteries are fitted on a bracket attached to the outside of the right-hand frame member. The bracket is covered by a metal casing which protects the batteries. See Fig. 10-1.

They are 12-volt lead-type storage batteries with a capacity of 114 ampere hours and these are connected in series to produce a voltage of 24 volts.

#### STARTER MOTOR

The starter motor, Fig. 10-2, is fitted to the flywheel housing on the right side of the engine.

The starter motor is a series motor, that is to say the armature and the field coils are connected in series. The starter motor meshes in the flywheel teeth by an axial movement of the armature and the pinion. The solenoid which is built into the starter motor first connects in the auxiliary field coil and the armature in series with the auxiliary field coil. The armature is thus drawn into the magnetic field and the pinion meshes with the flywheel gear while it is rotating slowly. The solenoid then connects in the main field coil and the starter motor commences to run at full output. The pinion is connected with the armature by means of a disk clutch. The disk clutch serves partly as an overload protector for the starter motor and partly as a disengaging mechanism when the engine has started and the flywheel teeth show a tendency to drive the starter motor.

## GENERATOR

The generator, Fig. 10-3, is fitted on the right side of the engine and is driven from the crankshaft by means of two belts.

The generator is of the shunt-type, that is to say the armature and the field coil are connected in parallel. The armature is carried in two ball bearings.

The charging capacity of the generator is controlled by a regulator.

## GENERATOR REGULATOR

The generator regulator, Fig. 10-4 is a contact generator of the vibrator-type, that is to say a continuous, rapid-action contact system. The generator regulator consists of a voltage regulator, a current regulator and a cut-out relay.

The voltage regulator controls the voltage of the generator in accordance with the degree of charge of the battery and loading on it. If the degree of charge, however, is so great that the maximum permissible generator charging current is reached, the current regulator operates and limits the current to its maximum value.

The cut-out relay is intended to prevent battery discharge. It cuts in when the generator is not running or has such a low speed that the generator voltage does not exceed the battery voltage.

## HORN

The horn, Fig. 10-5, is fitted on the left-hand headlamp bracket.

The horn is of the electro-magnetic type. Sound is produced by a diaphragm which is set in vibration by an electro-magnet. The windings in the electro-magnet are connected through a contact breaker. The contact breaker breaks the current to the winding each time the diaphragm is pulled towards the electro-magnet. A condenser is connected over the contact breaker and the function of this is to eliminate spark formation over the contact breaker points. See Fig. 10-6.

## CHARGING CONTROL LAMP

The charging control lamp is fitted on the instrument panel.

This lamp should be out when the truck is running but if it should remain on it shows that the generator is not charging or there is some fault in the generator regulator. When the engine is idling, its speed is low and since the generator is not charging, the lamp will be on.

The lamp receives its current from the main switch and is grounded through the generator armature when the engine is stopped. When the engine is running and the generator is

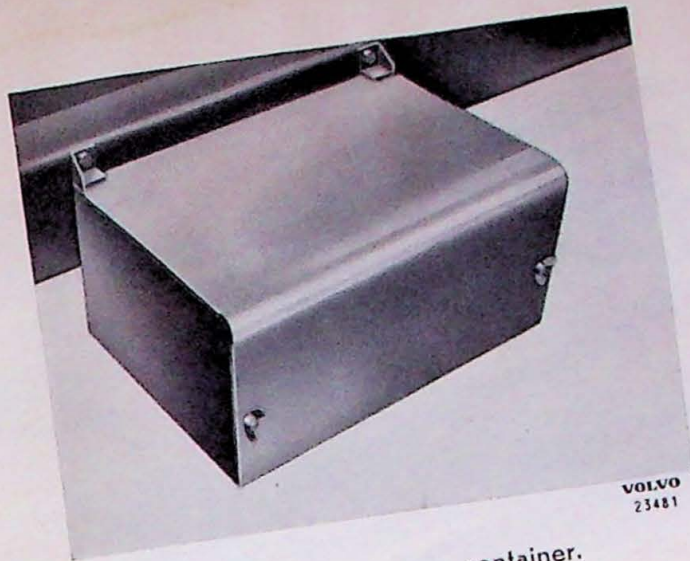

VOLVO  
23481

Fig. 10-1. Battery container.

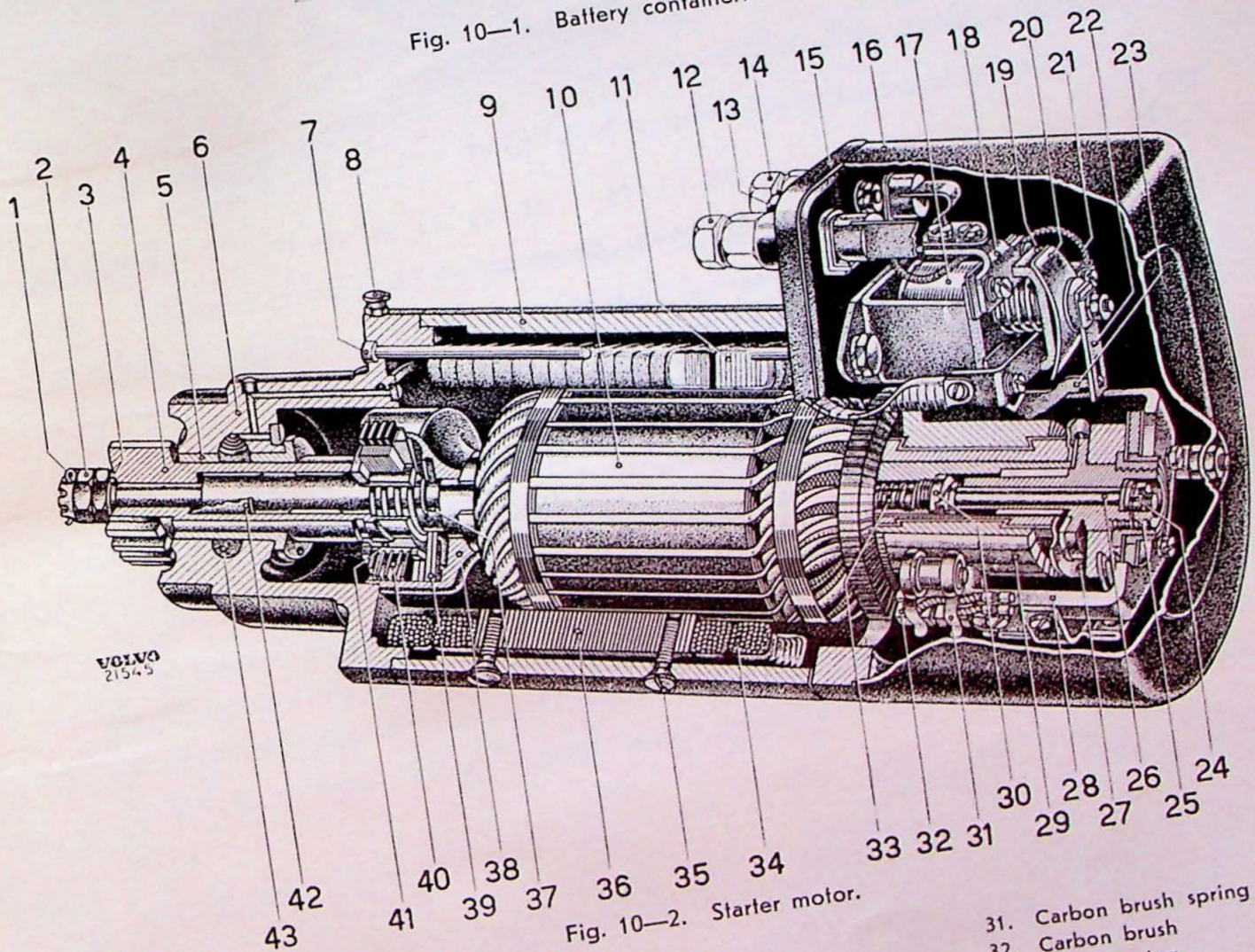

VOLVO  
21545

Fig. 10-2. Starter motor.

1. Cotter pin
2. Nut
3. Washer
4. Starter motor drive pinion
5. Bearing bushing
6. Drive end frame
7. Screw
8. Lubricator
9. Field frame
10. Armature
11. Main field coil
12. Feed terminal, negative
13. Solenoid terminal
14. Feed terminal, positive
15. Commutator end frame

16. Casing
17. Solenoid
18. Contact strip, positive
19. Contact bridge
20. Contact spring
21. Cable from auxiliary field coil
22. Catch plate
23. Catch cam
24. Nut for guide bolt
25. Bearing bolt
26. Guide bolt
27. Release washer
28. Carbon brush holder
29. Commutator
30. Nut for attachment of guide bolt

31. Carbon brush spring
32. Carbon brush
33. Return spring
34. Auxiliary field coil
35. Pole shoe screw
36. Pole shoe
37. Coil spring
38. Flange casing
39. Washer
40. Clutch disk
41. Clutch hub
42. Bushing
43. Lubricating wick

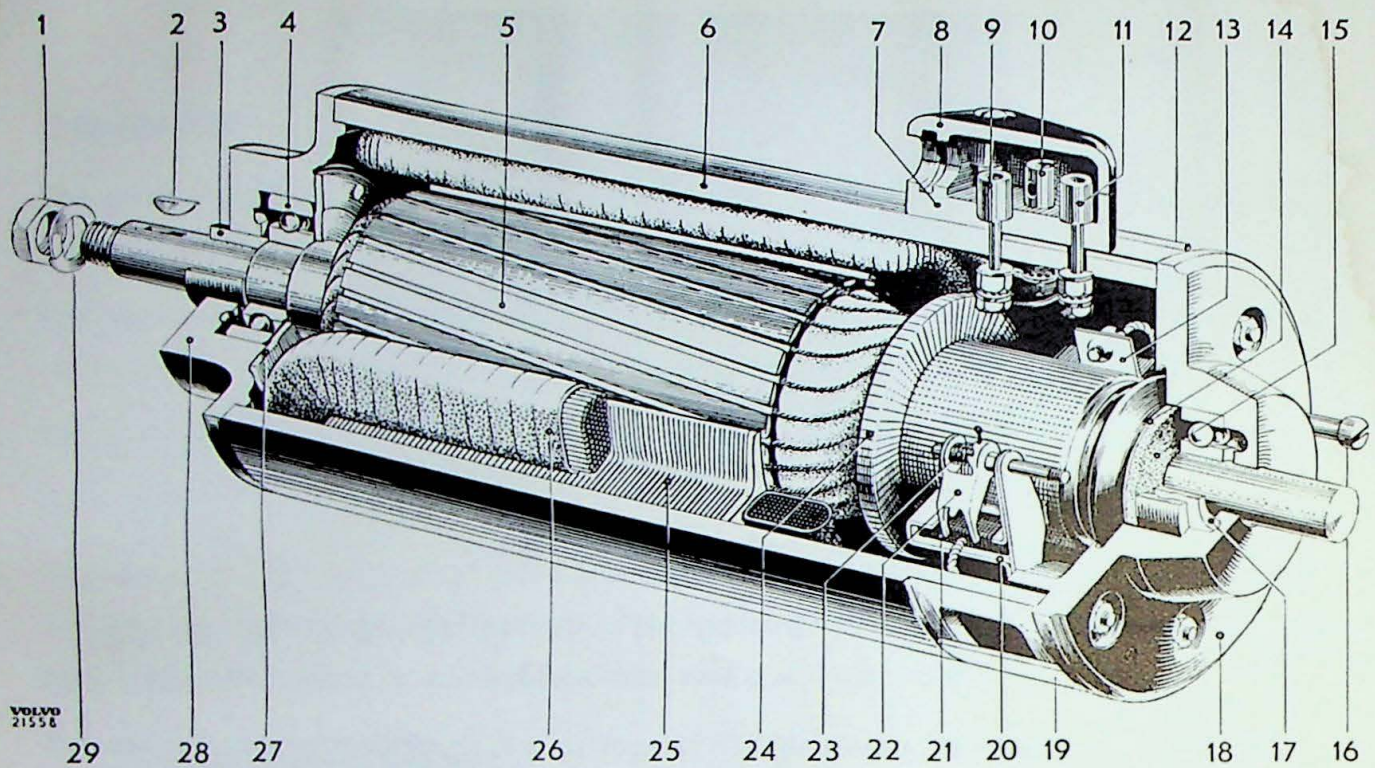

Fig. 10—3. Generator.

- |                              |                           |                     |
|------------------------------|---------------------------|---------------------|
| 1. Nut                       | 11. Negative terminal     | 21. Carbon brush    |
| 2. Key                       | 12. Cover band            | 22. Thrust arm      |
| 3. Spacer bushing            | 13. Carbon brush terminal | 23. Brush spring    |
| 4. Ball bearing              | 14. Washer                | 24. Commutator      |
| 5. Armature                  | 15. Packing               | 25. Pole shoe       |
| 6. Field frame               | 16. Screw                 | 26. Field coil      |
| 7. Connector block           | 17. Ball bearing          | 27. Washer          |
| 8. Cover for connector block | 18. Commutator end frame  | 28. Drive end frame |
| 9. F terminal                | 19. Cover band            | 29. Spring washer   |
| 10. Positive terminal        | 20. Carbon brush holder   |                     |

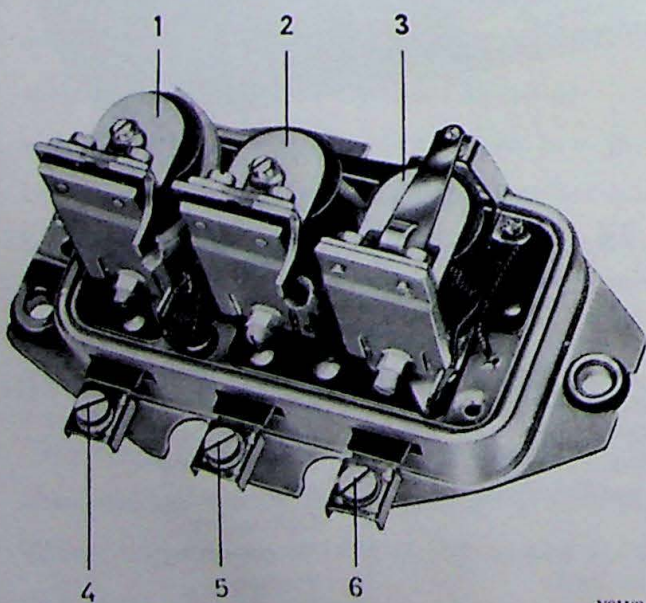

Fig. 10—4. Generator regulator.

- |                                                 |
|-------------------------------------------------|
| 1. Voltage regulator                            |
| 2. Current regulator                            |
| 3. Cut-out relay                                |
| 4. Terminal for cable from generator armature   |
| 5. Terminal for cable from generator field coil |
| 6. Terminal for cable from battery              |

charging, the voltage from the armature counteracts the voltage coming from the main switch and the lamp goes out.

### LIGHTING SYSTEM

Front lighting consists of two headlamps. These are fitted on the front fenders. There are two bulbs in each headlamp, one a double filament bulb for full and dipped headlamp beams and the other a parking light bulb.

The instruments are indirectly lit by the instrument lighting. This consists of 4 bulbs.

Tail lighting consists of two rear lamps fitted to the frame by means of brackets.

### SWITCHES

The headlamp switch is fitted on the instrument panel. This is of the twist-type with a central off-position. The foot-dimmer switch is fitted on the footplate and has two positions: full and dipped. The main switch is controlled by means of a key. Current to the starter button, the charging control lamp and the fuel gauge pass over the switch. The starter button consists of a spring-loaded push button which connects in current to the starter motor solenoid.

### FUEL GAUGE

The fuel gauge shows the amount of fuel there is in the tank. It is fitted together with the oil pressure and temperature gauges. The fuel gauge is operated by means of a sender fitted on the fuel tank and these two units are connected by means of a cable. The fuel gauge is wired over the main switch and only functions when the main switch is on.

### ELECTRICAL CABLES

All the units in the electrical system are connected by means of cables.

The electrical system on L 385 trucks is single-pole. Usually each unit in the system is connected by means of a single cable, the return circuit to the battery being through the chassis.

In order to avoid short-circuits, the cables must be very carefully insulated. Apart from their normal insulation, the cables are fitted with protector sleeves of plastic material or rubber.

The wiring diagram shows the connection of the cables as well as the way they are marked and their cross section.

## FUSES

The fuses are fitted in a fuse-box attached to the instrument panel.

The fuses, which are of the thermo-type consisting of wires over porcelain bases, are intended to protect the cables and units in the electrical system from dangerous overloading. A fuse is designed so that the thermo-wire melts when there is a short circuit or excessive current consumption either on a cable or on one of the units. The source of the fault is thus isolated from the remainder of the electrical system.

NOTE. Never replace burnt-out fuses with nails, copper wire etc.

## REPAIR INSTRUCTIONS

### BATTERIES

#### Removing

1. Remove the cover from the battery container.
2. Disconnect the cables from the batteries. Use a puller if the cable clamps have stuck on the terminals.
3. Loosen the retainer and lift out the batteries.
4. Clean the batteries with water externally.
5. Clean the battery container and the cable clamps.

#### Fitting

1. Fit the batteries in the container and tighten the retainer.
2. Tighten the cable clamps on the battery terminals and smear them with vaseline. Make sure that the cables are correctly connected. See the Wiring Diagram and Fig. 10-8.

### GENERATOR

#### Removing

1. Disconnect the ground cable from the battery.
2. Disconnect the cables from the generator.
3. Loosen the belt tensioner and lift off the belts.
4. Loosen the tensioner bolts and lift off the generator.