

#FC-66-686
\$2.50

FOREWORD

Frigiking

**Auto Air Conditioning
General Installation
And Service Manual**

be cared for in order to obtain the best performance. Many of the technical questions that occur to you and your customers are fully covered.

We sincerely hope that this manual will prove helpful in the installation and servicing of Frigiking auto air conditioning. In the event you have a special installation or service problem not covered in this manual, a call or letter to the Frigiking Company is always welcomed.

Don E. Robson
Technical Service Engineer
Frigiking Company

FRIGIKING COMPANY DIVISION • • CUMMINS ENGINE COMPANY
10858 HARRY HINES BLVD., DALLAS, TEXAS 75220

The information included in this manual is intended to aid in the installation and service of automobile air conditioners. Although reasonable care has been taken in its preparation to insure technical accuracy, no responsibility is assumed by the Frigiking Co. for any consequence of its use.

Copyright © 1966

by Frigiking Co. Printed in the United States of America. All rights reserved. This book, or parts thereof, may not be reproduced in any form without written permission from the publishers.

First Printing April 1966
Second Printing May 1967

INDEX

Chapter 1 Basic Principles of Automotive Air Conditioning

- 1. General 8
- 2. Sources of Cold 29
- 3. Removal of Heat 3
- 4. Heat Transfer of Heat 9
- 5. Three States of Matter 9

FOREWORD

This manual was written for both the amateur who wants to know how and the experienced automobile air conditioning mechanic who wants to know more about the installation and service of Frigiking auto air conditioners.

Explained, simply and clearly, are how a Frigiking auto air conditioner works, how it should be installed, and how it should be cared for in order to obtain the best performance. Many of the technical questions that occur to you and your customers are fully covered.

We sincerely hope that this manual will prove helpful in the installation and servicing of Frigiking automobile air conditioners. In the event you have a special installation or service problem not covered in this manual, a call or letter to the Frigiking Company is always welcomed.

- 1. General 25
- 2. York Compressors 25
- 3. Tecumseh Compressors 25
- 4. General Motors Compressors 25
- 5. Chrysler Compressors 25

Clutches

- 1. General 39
- 2. Clutch Removal 40
- 3. Clutch Installation 40
- 4. Trouble-Shooting 41

Receiver Tanks and Driers

- 1. Receiver Tanks 43
- 2. Driers 43
- 3. Combination Receiver-Driers 44
- 4. Sight Glass 44
- 5. Removal 44
- 6. Installation 44
- 7. Trouble-Shooting 44

INDEX

Chapter 1	Basic Principles of Automotive Air Conditioning	
	1. General	9
	2. Definition of Cold	9
	3. Definition of Heat	9
	4. Kinetic Theory of Heat	9
	5. The Three States of Matter	9
	6. Flow of Heat	10
	7. Three Methods of Heat Transfer	10
	8. Measurement of Heat	10
	9. Specific Heat	11
	10. Sensible Heat	11
	11. Latent Heat	11
	12. The Simple Refrigeration Cycle	12
	13. Pressure	12
	14. Pressure-Temperature Relationship	13
	15. The Refrigeration Cycle	13
	16. Basic Components of a Refrigeration System	14
	17. Refrigeration Accessories	15
	18. Refrigerant-12	15
	19. Pressure-Temperature Chart	16
Chapter 2	Evaporators	
	1. General	17
	2. Dash Mounted Evaporator Assemblies	17
	3. Trunk Evaporators	17
	4. Dual Evaporator Assemblies	18
Chapter 3	Condensers	
	1. Standard Condensers	19
	2. Special Condensers	19
Chapter 4	Expansion Valves	
	1. General	21
	2. Removal	22
	3. Installation	22
	4. Trouble-Shooting	22
Chapter 5	Compressors	
	1. General	23
	2. York Compressors	23
	3. Tecumseh Compressors	29
	4. General Motors Compressors	33
	5. Chrysler Compressors	35
Chapter 6	Clutches	
	1. General	39
	2. Clutch Removal	40
	3. Clutch Installation	40
	4. Trouble-Shooting	41
Chapter 7	Receiver Tanks and Driers	
	1. Receiver Tanks	43
	2. Driers	43
	3. Combination Receiver-Driers	44
	4. Sight Glass	44
	5. Removal	44
	6. Installation	44
	7. Trouble-Shooting	44

Chapter 8	Valves	
	1. Service Valves	45
	2. Suction Throttling Valves (STV)	46
	3. Evaporator Pressure Regulators (EPR)	47
Chapter 9	Electrical Equipment	
	1. General	49
	2. Motors	49
	3. Switches	50
	4. Rheostats	50
	5. Thermostats	51
Chapter 10	Hoses, Mounts, Pulleys and Belts	
	1. Hoses	53
	2. Mounts	53
	3. Pulleys	53
	4. Belts	53
Chapter 11	Automobile Cooling Systems	55
Chapter 12	Installation of the Unit in the Automobile	
	1. General	57
	2. Installing the Drive Pulley	58
	3. Installing the Compressor and Clutch	58
	4. Installing Compressor Mount and Idler Pulley	59
	5. Installing the Drive Belt	60
	6. Installing Condenser	60
	7. Locating the Evaporator Case Assembly	60
	8. Installation of Hoses	61
	9. Installing Evaporator Case Assembly	63
	10. Installing Electrical Wiring	63
	11. Evacuating the System	63
	12. Charging the System	63
	13. Check-Out after Charging	63
Chapter 13	Service Information	
	1. Test Manifold and Gauges	65
	2. Use of Gauge Manifold Set	65
	3. Discharging the System	65
	4. Evacuating the System	66
	5. Adding Refrigerant — Complete Charge	66
	6. Adding Refrigerant — Partial Charge	67
	7. Leak Detection	67
	8. Purging Air from the System	68
	9. Purging Excessive Refrigerant from the System	68
	10. Checking and Adding Oil	68
	11. New System Check-Out	69
Chapter 14	Trouble-Shooting	
	1. General	71
	2. Belt Troubles	71
	3. Vibration of Compressor and Mount	71
	4. Noisy Clutch	71
	5. Noise Complaints	71
	6. High Engine Temperatures	72
	7. Clutch Does Not Operate	72
	8. Blower Does Not Operate	72
	9. Blower Runs Too Slow	73
	10. No Cooling	73
	11. Not Enough Cooling	73
	12. Intermittent Cooling	73
	13. High Condensing Pressure	73
	14. Low Suction Pressure	73

Chapter 15	Service Tools	
	1. General	75
	2. Special Automotive Air Conditioning Tool List	75
Chapter 16	Periodic Maintenance Guide	
	1. Owner Maintenance	77
	2. Service Center Maintenance	77
Chapter 17	Safety Precautions and Pressure Temperature Chart	
	1. Precautions when handling Refrigerant	79
	2. Precautions when using Service Tools	79
	3. Precautions when Installing an Auto Air Conditioner	79
	4. Precautions when Servicing an Auto Air Conditioner	79
	5. Precautions to Keep System Clean and Dry	79

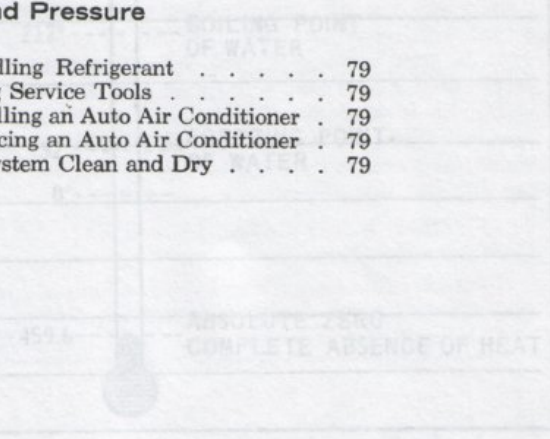

Fig. 1. Fahrenheit Temperature Scale

5. THE THREE STATES OF MATTER:

As you can see when using water as an example, it can be in three forms depending upon the amount of heat it contains: a solid, a liquid, or a gas. This is also true with all other forms of matter. Try to think of anything that is not either a solid, a liquid or a gas. No matter how hard you try, you will see that these are the only three forms of matter. You can also understand now that the state of all matter depends upon the amount of heat it contains.

3. DEFINITION OF HEAT:

Heat is a form of energy that is transferred from one object to another. It is not a substance, but a process. Heat is always thought of as being transferred from a warmer object to a cooler one. The term "cold" is not used to describe a state of matter, but rather a lack of heat. What is cold is a cup of water that has lost a lot of heat. In other words, it has lost a lot of heat.

4. HEAT'S PROPERTY OF HEAT:

Heat is a form of energy that is generally accepted as being transferred from one object to another. It is not a substance, but a process. Heat is always thought of as being transferred from a warmer object to a cooler one. The term "cold" is not used to describe a state of matter, but rather a lack of heat. What is cold is a cup of water that has lost a lot of heat. In other words, it has lost a lot of heat.

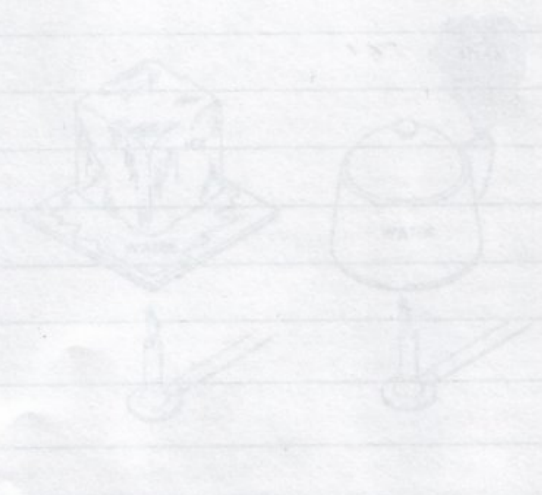

Fig. 2. Addition of Heat Causes Change of State

BASIC PRINCIPLES OF AUTOMOTIVE AIR CONDITIONING

1. GENERAL:

Refrigeration in the true sense of the word may be defined as the process of removing heat from a given space, thus reducing the temperature of the space below that of the surrounding environment. Mechanical refrigeration is defined as a mechanical system or apparatus so designed and constructed that, through its function, heat is absorbed or extracted.

Air conditioning, as we know it today, uses a mechanical refrigeration system to remove heat, moisture and dust from the air.

2. DEFINITION OF COLD:

Almost all definitions of refrigeration or air conditioning define it as the process of absorbing or extracting heat. We probably have always thought of air conditioning as being something cold, or even the creation of this cold. This is not true, the term "cold" is a relative thing. Such as "it is a cold day," or "my coffee is too cold to drink." What is cold for a cup of coffee may be hot when taking a bath. In either case, you are really describing how much or how little heat a thing contains.

3. DEFINITION OF HEAT:

Any definition of refrigeration or air conditioning contains reference to heat because heat is a real thing that can be transferred, measured and absorbed. Our school books have taught us that energy can be neither created or destroyed. Heat is a form of energy. So we are really concerned with the absorption and transfer of energy in refrigeration and air conditioning. This is in the form of heat energy.

4. KINETIC THEORY OF HEAT:

The Kinetic theory of heat is generally accepted, and assumes that the molecules that compose all substances are in constant motion. They are in motion as long as they contain energy. This energy is in the form of heat energy. So long as any substance contains any heat at all, the molecules that compose it are in motion. There is a point where all motion ceases, the point where no energy exists. That point is the complete absence of heat energy, or absolute zero. This would be measured on our Fahrenheit thermometer as 459.6 degrees below zero. If heat energy creates the motion of molecules, it stands to reason that the more energy or more heat a substance contains, the greater the motion of the molecules. This is true — take the example of water as we know it. It is a liquid, and contains a certain amount of heat. If you add heat to water, it becomes steam and the molecules are much more active. If you take heat away from water, it becomes ice and the molecules are less active.

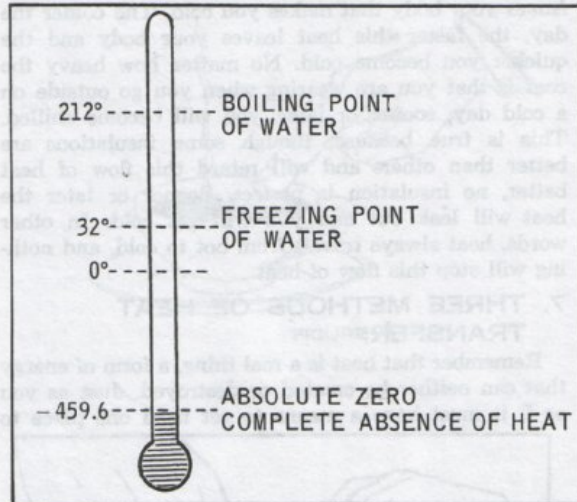

Fig. 1. Fahrenheit Temperature Scale

5. THE THREE STATES OF MATTER:

As you can see when using water as an example, it can be in three forms depending upon the amount of heat it contains: A solid, a liquid, or a gas. This is also true with all other forms of matter. Try to think of anything that is not either a solid, a liquid or a gas. No matter how hard you try, you will see that these are the only three forms of matter. You can also understand now that the state of all matter depends upon the amount of heat it contains.

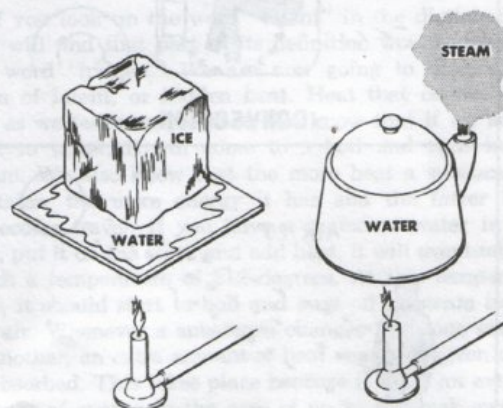

Fig. 2. Addition of Heat Causes Change of State

6. FLOW OF HEAT:

Heat always flows from a warmer spot to a cooler spot. In other words, from hot to cold. When you step outside on a cold day, the cold does not enter your body and make you cold. It's the fact that the heat leaves your body that makes you cold. The colder the day, the faster this heat leaves your body and the quicker you become cold. No matter how heavy the coat is that you are wearing when you go outside on a cold day, sooner or later, you will become chilled. This is true because, though some insulations are better than others and will retard this flow of heat better, no insulation is perfect. Sooner or later the heat will leak out and you will get cold. In other words, heat always travels from hot to cold, and nothing will stop this flow of heat.

7. THREE METHODS OF HEAT TRANSFER:

Remember that heat is a real thing, a form of energy that can neither be created or destroyed. Just as you or I, it must have a means to get from one place to

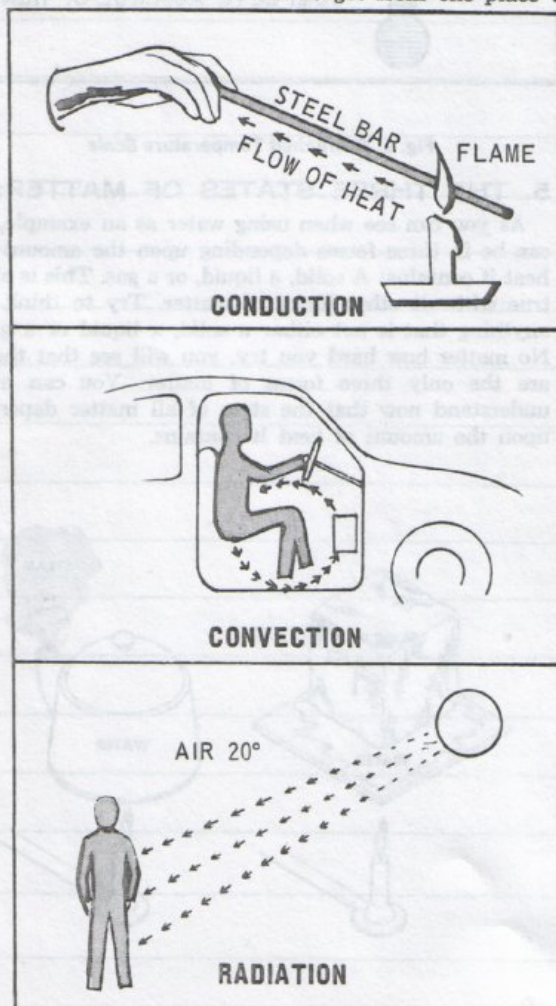

Fig. 3. Three Methods of Heat Transfer

another. Heat travels from hot to cold by three methods. It is conducted, as through a solid. If you hold a steel bar in a flame long enough, it would become too hot to hold. The heat energy would have traveled through the steel bar to where your hand held it. This method is known as conduction — through solid from molecule to molecule. Heat also travels by convection. This means it is conveyed by means of a third agent. It hitches a ride. On a cold day, the heat in your car blows the warm air on you and warms you. This means the heat is conveyed by the warm air from one place to another. The heat also was actually conveyed from the warm motor block into the heater core by the use of water or antifreeze. The third and last way that heat is transferred is by radiation. Radiation is the transmission of heat through space without heating the intervening space. A good example of radiation would be when you are standing outside on a cold day yet when the sun's rays strike your body, you are warmed beyond the temperature of the surrounding air.

8. MEASUREMENT OF HEAT:

Unless you are already familiar with the theory of heating and refrigeration, when we speak of measuring heat you will probably think of using a thermometer. And you would be half right. A thermometer is used to measure the intensity of heat. You can tell if something is hot or cold. If you put a thermometer in a pan of ice water it would read about 32 degrees, and if you put your finger in the same pan it would feel cold. Now if you put the same thermometer in a pan of boiling water, it would read 212 degrees. Your finger in the same water would probably produce a blister and you would concede that it was hot. In both cases you are measuring the intensity of heat only. If you put your thermometer in a one gallon pail of boiling water, it would read 212 degrees. If you put your thermometer in a five gallon pail of boiling water, it would also read 212 degrees. Obviously, there is more

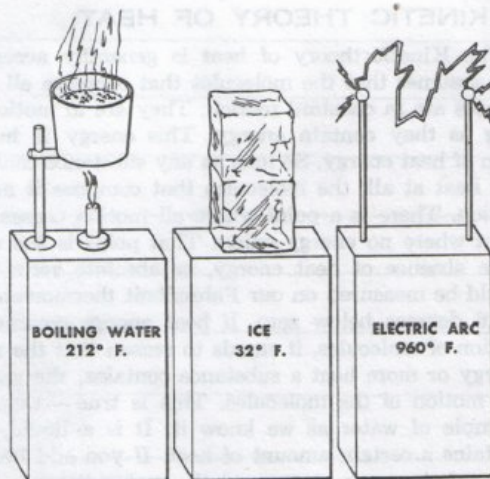

Fig. 4. Intensity of Heat

cold by through a solid. If you touch it, it would hurt, but you would not feel any heat. The energy would have to be transferred to your hand heat conduction — through the solid. Heat also travels by convection, and by means of radiation. On a hot day, the heat from the sun warms you, and warm air from the heater actually comes to you. The heater coil is the third and last method of heat transfer. Radiation is the only method that is necessary for heat to travel without heat conduction. On a cold day, the heat from the sun on a cold day warms your body, you are surrounded by air.

Some other instrument or way must be used if you want to measure the quantity of heat. To do this, we have created a unit of heat and called it a British Thermal Unit (or BTU for short). We have defined it as the quantity of heat necessary to raise one pound of water one degree Fahrenheit. While we usually are concerned with raising or lowering the temperature of water, the unit can still be used in air conditioning. All that is necessary is that we think alike and use the same unit at all times. In other words, if someone said that it took 100 BTU's to cool the occupants of an automobile, it's the same as saying the same amount of heat (if removed) would cool 100 pounds of water one degree, or one pound 100 degrees.

5. SPECIFIC HEAT:

If you understand the definition of a BTU, you can see that the amount of heat necessary to raise one pound of water one degree is one BTU. In other words, the Specific Heat of water is 1 (one). Water is the only substance we know which takes exactly one BTU to raise one pound one degree. Everything else takes more or less than one BTU to raise or lower one pound one degree. As an example, the alcohol that you might put in your car radiator requires only 6/10 of one BTU to raise one pound one degree. Therefore, the specific heat of alcohol is 0.600. The air that we breathe requires a little less than 1/4 of a BTU to raise the temperature of one pound one degree. Or one BTU would raise its temperature about four degrees. When someone has to calculate the amount of heat that must be removed from a space or a product, they must know the specific heat of the product before they can make the proper calculations. Usually they consult tables in reference books for this information.

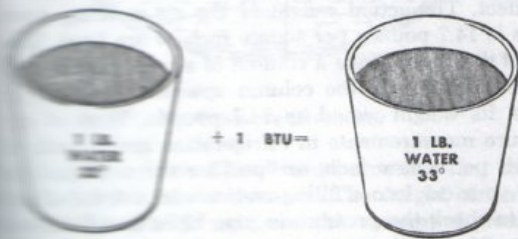
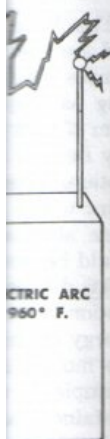

Fig. 5. Specific Heat

6. SENSIBLE HEAT:

We have learned that a thermometer measures only the intensity of heat. By intensity, we mean heat that we can feel or sense. We have also learned that the quantity of sensible heat can be measured by using

the BTU. It might come as a surprise to some of us to learn that there are some forms of heat that cannot be read on a thermometer or felt with our senses.



FIGURE A

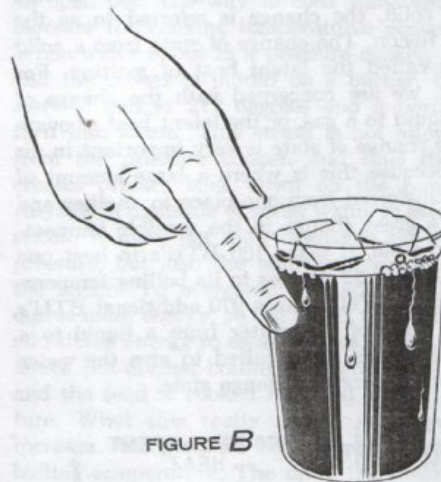

FIGURE B

Fig. 6. Sensible Heat

11. LATENT HEAT:

If you look up the word "latent" in the dictionary, you will find that part of its definition would include the word "hidden." We are now going to discuss a form of latent, or hidden heat. Heat that cannot be felt as we feel sensible heat. We know that if we add heat to water, it will come to a boil and turn into steam. We also know that the more heat a substance contains, the more energy it has and the faster its molecules travel. If you have a pound of water in a pan, put it on the stove and add heat, it will eventually reach a temperature of 212 degrees. At this temperature, it should start to boil and pass off as steam into the air. Whenever a substance changes from one state to another, an extra amount of heat energy is given up or absorbed. This takes place because it takes an extra amount of energy in the case of water to break away from being just water, and having the water molecules fly off into the atmosphere in the form of steam. Just as it would take you an extra amount of energy to get out of your chair and walk across the room it takes

the water molecules an extra amount of energy to break away from the rest of the water molecules and fly off as steam. This extra energy does not change the sensible temperature of the water or steam, but still has to be present if a change of state is to take place. Because the sensible temperature is not changed and we cannot feel the difference, yet it is present, this additional heat is called "latent," or hidden heat. In reverse, if a pound of steam were to turn back into water, it must give up this additional energy before a change of state could take place. The following example might also be given: If you had a pound of water at 32 degrees and wished to have a pound of ice at 32 degrees, you would have to take away a certain amount of energy to cause the water molecules to slow down enough to become ice. Yet, the sensible temperature of 32 degrees still remains. When the change of state is from a liquid to a gas, it is referred to as the latent heat of vaporization. When the change of state is from a liquid to a solid, the change is referred to as the latent heat of fusion. The change of state from a solid to a liquid is called the latent heat of melting. For the most part, we are concerned with the change of state from a liquid to a gas, or the latent heat of evaporation. This change of state is very important in air conditioning because this is where a large amount of heat can be transferred from one place to another and still not have a great change in the sensible temperature. As an example, it takes 180 BTU's to heat one pound of water from 32 degrees to its boiling temperature of 212 degrees. Yet it takes 970 additional BTU's to change the state of this water from a liquid to a gas. These 970 BTU's are required to give the water molecules enough energy to change state.

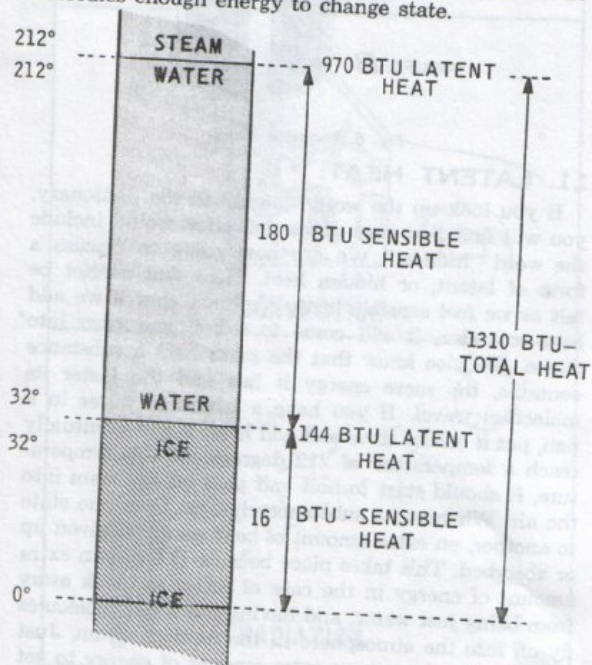

Fig. 7. Heat Chart for Water

12. THE SIMPLE REFRIGERATION CYCLE:

The refrigeration cycle in an automobile air conditioning system employs most of the foregoing facts and uses a mechanical means to accomplish the absorption and removal of heat from the space to be conditioned. The alcohol in your car radiator boils around 170 degrees. As you can see, different liquids have different boiling temperatures. In refrigeration, a liquid is selected that has an extremely low boiling temperature. The refrigerant that we most commonly use boils at a temperature of minus 21 degrees below zero. Remember that "boiling" as we refer to it, does not necessarily mean something hot, but rather the change of state from a liquid to a gas. The refrigerant that we use changes state from a liquid to a gas at minus 21 degrees, and heat must be absorbed to accomplish this change. When water boils and changes state, we must furnish a source of heat. If we use a refrigerant with such a low boiling temperature, we can use the very air in the automobile as the source of heat, and thus cool the air. This is the basic principle of air conditioning and refrigeration. We boil a liquid refrigerant in a container in the space we want to have air conditioned, and thus absorb heat from the space. The liquid has now turned into a heat filled gas. This gas is removed from the air conditioned space, and the heat is then removed from the gas. When heat is removed from a gas, it turns back to a liquid. This liquid is then circulated back to the air conditioned area, and the cycle can be repeated. If you stop to think about it, you will see that all of the things we have learned in the preceding paragraphs apply and are used in this simple refrigeration cycle.

13. PRESSURE:

Just as everything, as we know it, contains some heat energy, everything also is at a pressure of some kind. The air surrounding you exerts internal and external pressure on your body. Because the pressure inside your body is the same as the pressure on the outside, we often ignore its existence because it has no effect. The actual weight of the air pressing down on us is 14.7 pounds per square inch at sea level. This means that if you take a column of air one square inch in area and extend the column upwards as far as air exists, its weight would be 14.7 pounds. Most of our pressure measurements in refrigeration are in units of pounds per square inch, or "psi" for short. When you drive your car into a filling station and ask the attendant to check the pressure in your tires, or tell him to put in 28 pounds, you mean 28 psi. Remember, the actual air surrounding us is at a pressure of 14.7 psi. This pressure is wherever there is any air at all. So if you had a flat tire while driving your car, even the tire when flat would contain 14.7 psi. This means that when you told the filling station attendant to fill your tire with 28 pounds of air, you actually meant to put in 28 pounds more than the 14.7 pounds that it already contained. This may all sound quite confusing, but the

ATION

mobile air cond...
foregoing fact...
mplish the ab...
the space to b...
adiator boils a...
different liquid...
refrigeration...
ly low boiling...
most common...
degrees below...
fer to it, doe...
but rather th...
The refrigeran...
a gas at minu...
to accomplish...
nges state, we...
e a refrigeran...
e can use the...
e of heat, and...
ple of air con...
uid refrigerant...
ave air condit...
ce. The liquid...
This gas is re...
nd the heat is...
removed from...
is then recir...
and the cycle...
ut it, you will...
ed in the pre...
this simple

contains some...
sure of some...
internal and...
the pressure...
ssure on the...
ecause it has...
ressing down...
a level. This...
e square inch...
as far as air...
Most of our...
e in units of...
t. When you...
sk the atten...
r tell him to...
member, the...
of 14.7 psi...
air at all. So...
ar, even the...
means that...
t to fill your...
eant to put...
at it already...
ing, but the

thing to remember is that there are really two types of pressure measurements. The measurement that ignores the existence of the pressure of the air surrounding us, and the measurement that takes into consideration the pressure of the air surrounding us. The first pressure measurement is called "psig," or pounds per square inch gauge. (Such as the tire gauge at the filling station attendant's pocket.) The second is called "psia," or pounds per square inch absolute. This type of gauge is usually used only in scientific laboratories.) The units of pressure measurement in refrigeration service work are in psig, which means that we are concerned with only the pressures above or below that which normally exist in the air surrounding us. Because we ignore the air pressure surrounding us and only read the pressures more or less than this pressure, we call the pressure of the air "0" psig, and the gauge then measures only that above or below this point. Any pressure that is above 0 psig is measured in additional pounds per square inch. When the pressure to be measured is less than 0 psig, we must use a measurement other than pounds. This measurement is inches of vacuum. A vacuum is defined as any pressure less than atmospheric, or in our case, any pressure less than 0 psig. To understand why we use the measurement of inches instead of pounds, refer

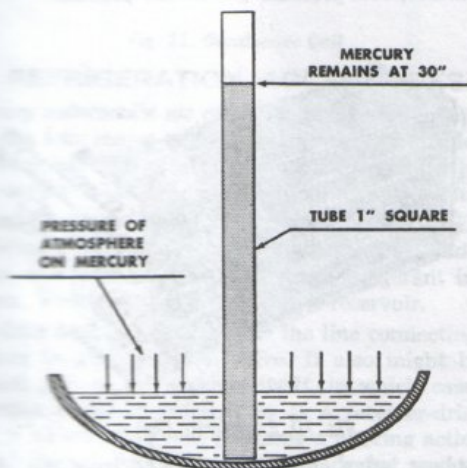

Fig. 8. Simple Barometer

to Fig. 8. This figure illustrates a barometer that measures barometric, or air pressure. The weight of normal air at sea level is 14.7 psia, and this amount of pressure will hold a column of mercury up in the barometer tube 29.92 inches. What this means is that a column of mercury 29.92 inches in height weighs 14.7 pounds, the same as a column of air weighs 14.7 pounds. Any time the weight of air is less than 14.7 psia or 0 psig, it will not be able to hold this column of mercury as high in the tube. The mercury will drop in the tube any time the weight of air holding it up is less than 0 psig. The refrigeration gauge that we use is scaled in inches on

the vacuum range, and measures the distance the column of mercury will drop in the tube when the air pressure is reduced below 0 psig. The gauge is scaled from zero to 30 inches. If you had a perfect vacuum at sea level, the column of mercury would drop 29.92 inches in the tube. A refrigeration gauge constructed to read only pressures above 0 psig is called a pressure gauge. A gauge constructed to read both pressure and vacuum is referred to as a compound gauge.

14. PRESSURE-TEMPERATURE RELATIONSHIP:

If the pressure within the closed vessel is increased, the temperature will also increase. If the pressure is reduced, the temperature will reduce. Most of us are familiar with an ordinary pressure cooker. Water in an open pot boils at 212 degrees. A pressure cooker is designed to cook food faster than can be done using an open pot. The way to cook something faster is to increase the cooking temperatures above 212 degrees. When water is put in a pressure cooker, the lid sealed and the cooker is placed on a burner, the water will start to boil at 212 degrees and a portion of it will turn into steam. This steam is not allowed to escape from the pressure cooker, and thus the pressure it creates presses back down on the remaining water. Anytime a molecule of water wants to escape to become steam, it must not only overcome the normal 0 psig pressure, but also the additional pressure exerted by the steam. To overcome this additional pressure requires more energy, so the water molecule must absorb additional energy to escape. Thus, its temperature rises above the normal boiling temperature of 212 degrees, and the food is cooked faster at this higher temperature. What this really means is that anytime you increase the pressure on a liquid, you increase its boiling temperature. The more the pressure on top of a liquid is increased, the higher its boiling temperature becomes.

The reverse of this is also true. If you decrease the pressure exerted on a liquid, you decrease its boiling temperature. The more you decrease the pressure, the lower the boiling temperature will be.

As you can see by controlling pressures, you can actually control operating temperatures. This is how a refrigeration system works: The pressures throughout the system are controlled and thus the temperatures are also controlled.

15. THE REFRIGERATION CYCLE:

Now that we understand the various relationships between temperatures, pressures, and heat—an actual refrigeration system can be explained in detail. First a liquid is selected that has a low boiling point at 0 psig. This is necessary in order to use the air in the automobile as the source of heat. Remember that heat flows from hot to cold, so if a liquid (or refrigerant) is selected that has a boiling temperature below the temperature of air, the heat will flow from the air to the liquid refrigerant. This will cause the air to become

cool and the liquid refrigerant to absorb latent heat and boil away to become a gas. This boiling action, or absorption of latent heat, takes place in a closed circuit, and the refrigerant is piped from one location to another within the system.

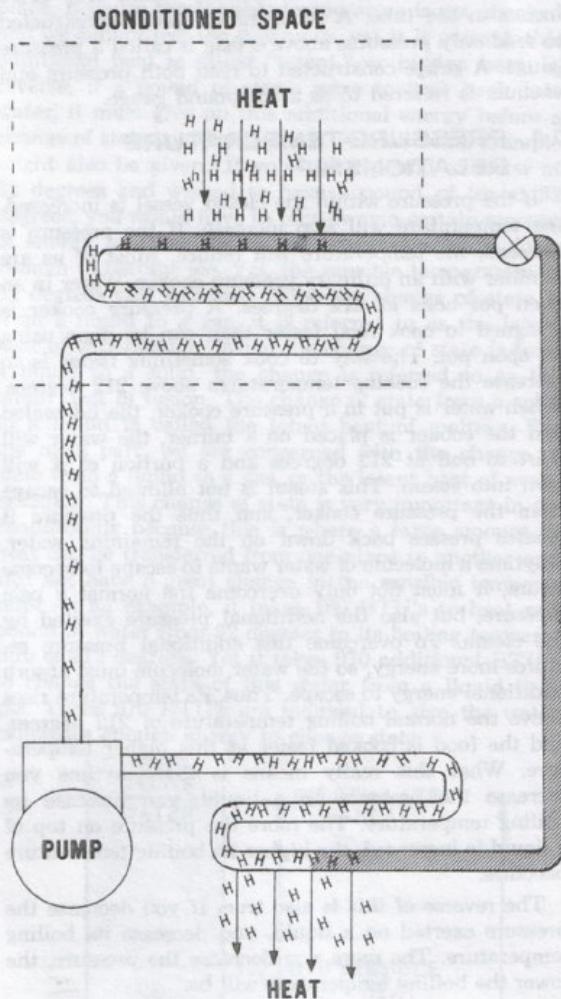

Fig. 9. Refrigeration Cycle

Once the liquid refrigerant has absorbed latent heat and turned to a gas, it is necessary to remove this latent heat from the gas to allow it to change state back to a liquid so it can be used over again to cool more air. A pump is used to suck this latent heat laden gas from the conditioned area to an area where the latent heat is given up and the gas returns to a liquid state. Again, heat always travels from hot to cold, and the gas sucked out of the conditioned area is now pumped into a finned coil. This pumping action results in increased pressure. When the pressure goes up, the temperature also rises. The pump continues to raise both the temperature and pressure of this heat laden gas until its temperature is above that of the surrounding outside air. Once this happens, the heat

will flow from the hot gas to the cooler air and the gas will change state back to a liquid again. This liquid is then recirculated to the conditioned space, and the cycle is repeated.

16. BASIC COMPONENTS OF A REFRIGERATION SYSTEM:

An air conditioning system is composed of four basic components. These components may be constructed in various ways and shapes, but they always perform the same function in a refrigeration system and are always installed in the same relative position to each other.

We refer to a refrigeration cycle, or in other words a circle. This means the system is closed, and there is no actual starting or ending point. For convenience let's begin the refrigeration cycle at the expansion valve. The expansion valve is a device that meters and controls the flow of liquid refrigerant through the system. It permits just the right amount of high pressure, high temperature liquid to enter the cooling coil or evaporator.

The evaporator is an arrangement of tubes and fins that is located in the conditioned space. The high temperature, high pressure liquid moves past the expansion valve and absorbs heat from the air through the evaporator tubes and fins, as it turns into a low temperature, low pressure gas in the process.

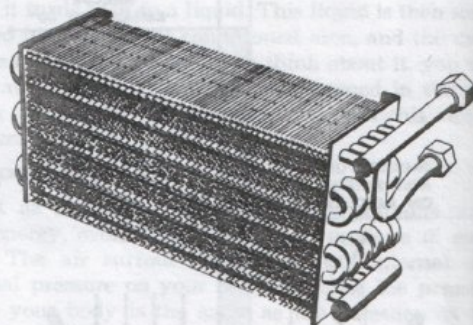

Fig. 10. Evaporator Coil

This heat laden gas is then sucked from the evaporator by the compressor. The compressor performs a dual action of pulling the suction gas from the evaporator, thus maintaining a low pressure in the evaporator, compressing this gas and pushing it out under high temperature and pressure into the condenser coil.

The condenser coil is another arrangement of tubes and fins similar in construction to the evaporator coil. Where the heat flow in an evaporator is from outside to inside the coil, the heat flow in a condenser is from inside of the coil towards the outside. The condenser coil is located in an unconditioned area, and after the compressor has compressed the gas to a high pressure and temperature, the condenser rejects this latent heat to the outside air so the refrigerant gas can turn back

into a liquid. Bear in mind that the compressor must raise the pressure, and thus the temperature of the gas to a point where the gas is at a higher temperature than the surrounding air. The heat can then flow from the warmer gas to the cooler air around the condenser. In an automobile air conditioning system, this heat transfer is helped along by the radiator fan forcing air over the condenser coil.

Once the gas has turned back to a high pressure, high temperature liquid in the condenser coil, it is forced up a line and back through the expansion valve. The cycle is then repeated.

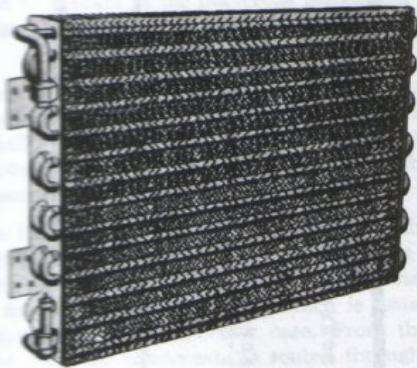

Fig. 11. Condenser Coil

17. REFRIGERATION ACCESSORIES:

Every automobile air conditioning system must contain the four major components in order to function. However, to function efficiently and be controlled properly, several other items are added to the system.

Most systems contain a receiver located after the condenser. This receiver is a tank of some kind that serves as a container for the excess refrigerant in the system. You might refer to it as a reservoir.

A drier is also usually put in the line connecting the receiver to the expansion valve. It also might be an integral part of the receiver itself, in which case the assembly would be referred to as a receiver-drier. A drier is an assembly that performs a filtering action on the refrigerant, and also contains a drying agent that absorbs harmful moisture particles from the refrigerant.

Sight glasses or liquid indicators are small assemblies inserted in the line connecting the condenser to the expansion valve. They also might be a part of the receiver-drier assembly or the expansion valve. The assembly has a window that allows the serviceman to look into the system and observe the flow of liquid refrigerant in the system. They are a valuable aid in service work.

A variety of other items are sometimes inserted in the connecting refrigerant lines that serve to control and regulate the flow of refrigerant. Some of the various controlling agents are called evaporator pressure regulating valves, suction pressure valves, high pressure

cutouts, low pressure cutouts, and crankcase pressure regulating valves. These valves are all explained later in the manual.

In order to control and regulate the proper conditioned space temperature, the electrical system of the air conditioner contains switches, rheostats, blower motors, electric clutches, dampers and many other useful items.

An air conditioning installation will also have belts, hoses, brackets, special mounts, fittings and other mechanical items to make a complete working system.

18. REFRIGERANT-12:

There are many different refrigerants available today that can be used in refrigeration systems. The automobile air conditioning industry uses Refrigerant-12 without exception because it has the most desirable characteristics for this application.

Refrigerant-12 is clean, dry and free from contamination as received in factory containers. It is non-toxic, non-corrosive, non-inflammable, non-explosive and odorless under ordinary usage.



Fig. 12. Refrigerant-12 15 oz. Disposable Can

Refrigerant-12 has a low boiling point at atmospheric or 0 psig. This boiling point is minus 21 degrees F., and enables us to have pressures above zero psig in the evaporator section, and still have low boiling temperatures to effect a good heat transfer or flow. It is always easier to work in a pressure range than a vacuum range.

This refrigerant also has a good latent heat of vaporization value. In other words, if a pound of Refrigerant-12 is boiled off in the evaporator, it will absorb a large quantity of heat from the air to do this. The more heat that is absorbed by each pound of refrigerant, the less refrigerant you will have to circulate, pump and condense. This can amount to a considerable savings in weight, refrigerant and horsepower.

19. PRESSURE-TEMPERATURE CHART:

We have already learned that every liquid has a different boiling temperature and that if you vary the pressure exerted on a liquid, you will also vary this boiling temperature. We are now concerned only with the pressure-temperature relationship of Refrigerant-12. When a serviceman observes the pressures of the boiling refrigerant in the evaporator or the pressures of the condensing gas in the condenser, he can then refer to a chart (see Table 1) and determine the actual temperatures in these different locations. By observing pressures and temperatures in an air conditioning system, the serviceman can often make service diagnosis.

In order for a temperature-pressure relationship to exist (such as shown on the chart), there must always be a mixture of liquid and gaseous refrigerant present. This is referred to as a "saturated condition." If no liquid is present, then a rise in temperature cannot boil off some of the liquid and create an additional rise in pressure. Think back to the example of the pressure cooker, and you will see that pressure can only be increased by boiling the water to steam. Thus, if water is not present the pressure cannot increase. Fortunately, for the most part, a saturated condition does exist in the parts of the refrigeration system we are most concerned with.

An example or two might enable you to better understand the real value of your pressure-temperature chart. Let's assume that an air conditioned car would have the interior air temperature at a comfort level of 72 degrees. If this air is circulated over the evaporator coil to be further cooled, then the evaporating temperature must be less than 72 degrees before heat can flow from the 72 degree air. The actual evaporating temperature might be 35 degrees. Now the serviceman knows that his evaporating temperature should be

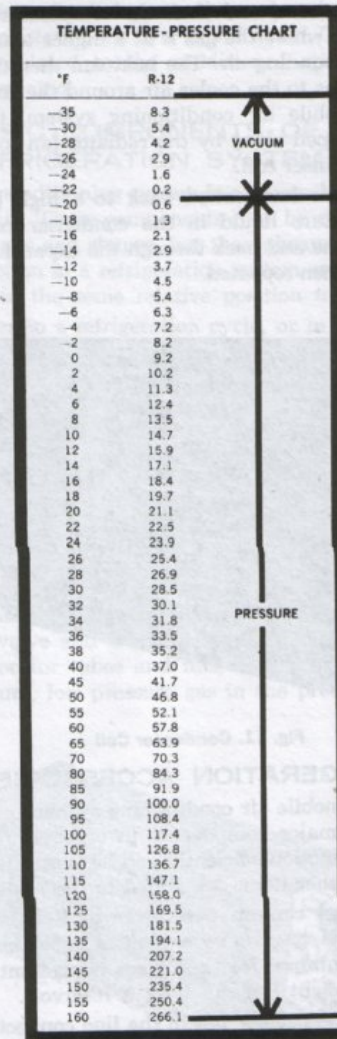

Table 1. Temperature-Pressure Chart

approximately 35 degrees, and by observing the pressure on his service gauge he can refer to the pressure-temperature chart and determine if the temperature is correct. The same situation holds true on the condensing side of the system. If the air passing over the condensing coil on a hot day is 90 degrees, we know that the temperature of the gas must be greater than 90 degrees if latent heat is to flow from the hot gas to the air. When operating properly, this condensing pressure might be somewhere around 190 to 200 psig. By referring to the pressure-temperature chart, you can see that the actual condensing temperature would be between 130 and 140 degrees.

EVAPORATORS

1. GENERAL:

The purpose of an evaporator in an auto air conditioning system is to absorb heat from the automobile passenger area.

The evaporator coil is of fin and tube construction, and is made complete with inlet and outlet manifolding. Proper manifolding results in equal distribution of liquid refrigerant in the numerous passes and tubes. The aluminum fins greatly increase heat transfer efficiency.

Reference is usually made to an evaporator assembly in an automobile air conditioning system. This assembly usually consists of the evaporator coil, blower fan and motor, expansion valve, controls, and a finished case assembly with adjustable air-flow louvers.

Since the evaporator coil is colder than the air passing over it, the coil will condense the moisture in the air. This condensed moisture will run down the evaporator fins and into a drip pan, which is usually an integral part of the evaporator case. From the drip pan, the collected condensate is routed through drain hoses to outside of the automobile.

There are times when the boiling temperature of the liquid refrigerant in the evaporator coil gets low enough to freeze the condensate into ice on the tubes and fins. This ice formation blocks air flow and prevents cool air distribution to the passenger area. The air conditioning serviceman may encounter this problem, and should be aware of its origin. Many manufacturers have incorporated safety devices into their systems to prevent the problem, but under certain humidity and driving conditions, this coil icing can still occur.

The thermostat and fan switches are usually located on the evaporator faceplate, which allows the driver to adjust for temperature and air volume. Adjustable louvers allow the driver to adjust the direction of air flow.

2. DASH MOUNTED EVAPORATOR ASSEMBLIES:

This evaporator is located under the instrument panel in the front compartment. Cooled air is discharged through adjustable louvers, and all controls are conveniently located for driver adjustment.

The assembly is usually designed especially to fit various makes and models of automobiles. Therefore, many different sizes, shapes and configurations may be encountered.

Essentially, they all perform the same function and vary only in physical characteristics.

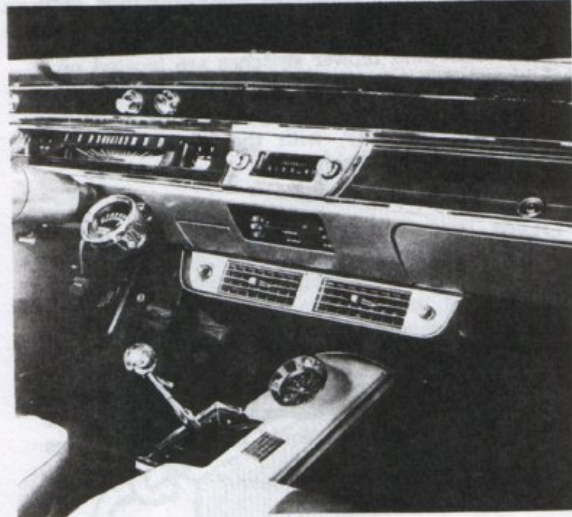

Fig. 13. Typical Dash Mounted Evaporator

3. TRUNK EVAPORATORS:

In some instances, the evaporator assembly may be located in the automobile trunk. This may be for convenience, or because available space does not permit installation under the instrument panel. Generally speaking, a trunk installation is more expensive and is considered to be a custom installation.

The evaporator case is not finished with a faceplate or louvers, but includes an evaporator coil, expansion valve, fan and blower assembly, and a duct arrangement to convey the cooled air to and from the conditioned auto area.

Two directional, adjustable louver assemblies are usually provided with the installation. They are located on the flat surface behind the back seat, and

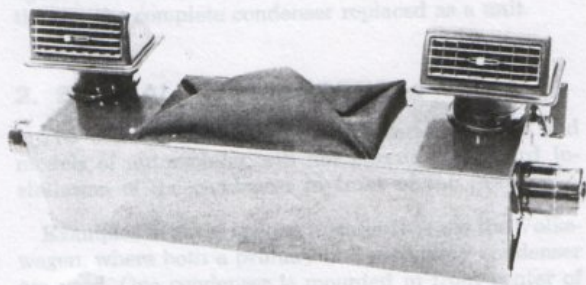

Fig. 14. Trunk Evaporator Assembly

blow cool air from rear to front throughout the passenger area. A return air grille is also provided for installation in the same area.

Additional lengths of hoses and wiring must be provided because of the distances separating the components.

Thermostatic and blower switches are located on a panel installed in a convenient driver location. The system operates and functions the same as an underdash mounted assembly, with the exception of the location of various components.

4. DUAL EVAPORATOR ASSEMBLIES:

The dual evaporator system is a special application system that is used on ambulances, armored cars, florist delivery wagons and limousines. Basically, it is two evaporators connected in parallel and operating from a single compressor, condenser and clutch. Each evaporator has its own expansion valve, and control is accomplished by the use of liquid line solenoid valves

installed in either or both lines leading to the individual expansion valves. If two solenoid valves are used, each evaporator is wholly independent of the other, and both can be on or off at any one time without regard to the operation of the other evaporator. The wiring would be such that each evaporator would have its own thermostat control, with either thermostat operating the clutch on or off in response to thermostat action.

The system may be installed with only one solenoid valve. Under this arrangement, one evaporator thermostat would operate the clutch and the other thermostat would open and close the solenoid valve to its evaporator when cooling is required.

Oversize condensers are usually required because the condensing load has been doubled. The system also has to have a high capacity compressor, and at low speeds it may not be possible to obtain maximum cooling from both evaporators.

The dual system has many and varied applications, and can be incorporated on any vehicle.

CONDENSERS

STANDARD CONDENSERS:

In most automobile air conditioning systems, the condenser is located in front of the radiator so that it is in the stream of air passing through the radiator.

The purpose of a condenser in a refrigeration system is to conduct the latent heat in the entering hot discharge gas to the air flowing over the condenser coils and fins. When a gas loses its latent heat, a change of state takes place and it becomes a liquid. This action is referred to as "condensing," and the pressure and temperature of the discharge gas is called "condensing pressure" or "high side pressure," and "condensing temperature."

How fast this condensing action takes place depends upon the physical size of the condenser and the quantity and temperature of the air passing over the condenser fins. As an automobile engine speeds up and slows down, the radiator fan moves more or less air over the radiator and the condenser. As the seasons vary or time of day changes, so will the temperature of the air passing over the radiator and the condenser. Therefore, as the quantity and temperature of the air varies, so will the condensing pressure and temperature vary. You can expect to observe a higher condensing pressure on a hot day than on a cold day. You can also expect the condensing pressure to be higher when the car is idling or in city traffic, rather than on highway driving.

The condensing action is a continuous process as long as the air conditioner is in operation. The compressor will force hot discharge gas into the condenser, raising the condensing pressure and temperature until a point is reached where as much gas is turning to liquid as the compressor is forcing into the condenser. When this point of equilibrium is reached, the condensing pressure will remain constant as long as the volume and temperature of the air across the condenser remains the same. If any factor that affects condenser capacity changes, the condensing pressure will immediately increase or decrease to adjust to this change.

Under severe operating conditions the condensing pressure may rise to such a point that the compressor is unable to overcome the pressure. When this occurs, severe damage to the compressor, or hose bursting, belt slippage and breakage will result.

As the condensing pressure depends upon engine speed and the temperature of the entering air, it cannot be controlled to any great degree. However, care should be taken to see that the condenser is properly located at a minimum distance of 1/2" from the radiator, and that the fins are not crimped, turned or bent in such a manner that will restrict air flow. The fins

must be kept free from bugs, dirt and other obstructions.

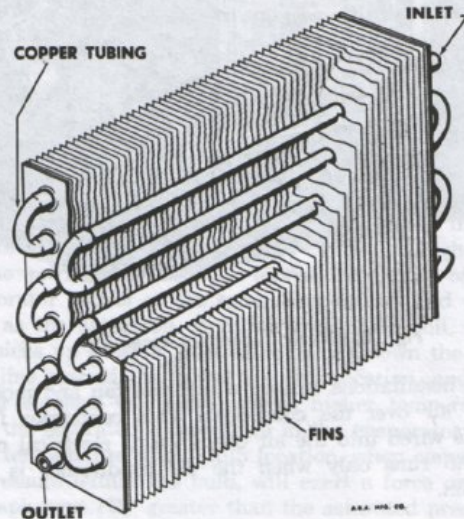

Fig. 15. Typical Two Row Condenser Construction

If too much refrigerant is charged into an auto air conditioning system, this additional amount is apt to fill up the receiver-drier and back up and collect in the bottom rows of the condenser coil. Any portion of the condenser coil that is filled with liquid cannot be used to transfer heat from the gas to the air, and a higher condensing pressure will be the result.

Condensers are constructed of copper tubes and aluminum fins, and no service should be necessary unless a leak develops or the part is physically damaged. A leak may be repaired depending upon its location, or the complete condenser replaced as a unit.

2. SPECIAL CONDENSERS:

The construction and design of certain makes and models of automobiles will not permit a standard installation of the condenser in front of the radiator.

Examples of these special installations are the Volkswagen, where both a primary and secondary condenser are used. One condenser is mounted in front center of the car beneath the bumper, and the other is located near the rear axle. The Corvair has its condenser mounted in the luggage compartment.

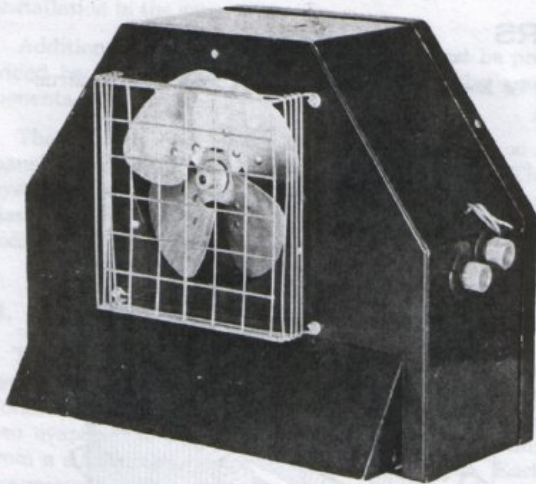

Fig. 16. Corvair Condenser Assembly

Both installations require a separate fan and motor to pull air over the condenser. This condenser fan motor is wired into the air conditioning electrical circuit, and runs only when the air conditioner is in operation.

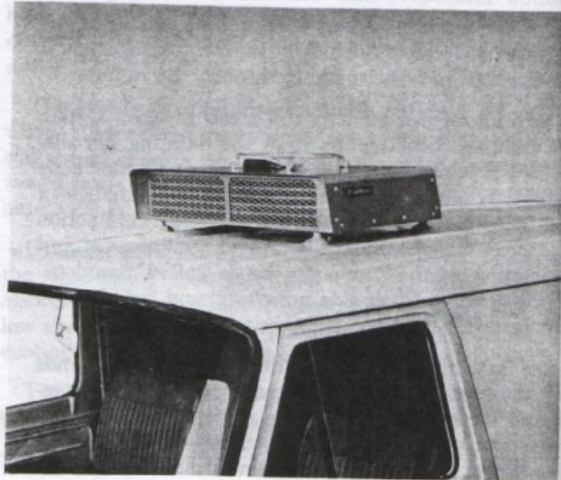

Fig. 17. Overhead Condenser Installation

The location of the special condenser is the only deviation from a standard installation.

EXPANSION VALVES

1. GENERAL:

Control of liquid refrigerant entering the evaporator is accomplished by the use of a thermostatic expansion valve. This valve controls the rate of liquid flow into the evaporator. It meters refrigerant according to the load, and maintains maximum evaporator efficiency. Enough liquid refrigerant is metered to maintain a "boiling" condition throughout the complete evaporator, yet this "boiling" action does not extend out of the evaporator and into the suction line.

The expansion valve is one of the dividing points between the high and low sides of the system. Refrigeration, or absorption of heat begins at the outlet side of the valve. It is the coldest point in the system. High pressure liquid enters the evaporator through a variable size orifice in the expansion valve, and is reduced in pressure and temperature. It then "boils" or picks up latent heat in the evaporator coil, and is turned to a low pressure gas in the process.

Three forces combine to operate the thermostatic expansion valve: (1) Spring force below the diaphragm, (2) Suction pressure below the diaphragm, (3) Power element pressure above the diaphragm. See Fig. 18.

Power element of bulb (A) and the connecting tube (C) are charged with either a liquid or gaseous refrigerant. The bulb (A) is clamped securely to the evaporator outlet, and responds to suction gas temperature. An increase or decrease of this suction gas temperature, the temperature and therefore the pressure of the refrigerant in the power element also increases or decreases. The power element pressure is exerted on the top of valve diaphragm (B), and an increase in pressure will tend to open the expansion valve. A decrease in pressure will tend to close the valve.

The forces tending to keep the expansion valve in a closed position are suction pressure, which is exerted on the underside of diaphragm (B) and spring pressure (D), which also exerts a pressure on the underside of the diaphragm (B).

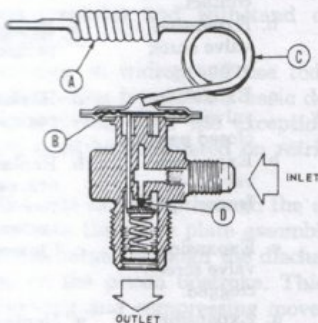

Fig. 18. Expansion Valve

It is apparent that the pressure in the power element (A) must be greater than the total of the suction pressure and the spring force if the expansion valve is to allow liquid refrigerant to enter the evaporator.

Within the evaporator coil a saturated condition exists, that is, some liquid and gas. By the time the refrigerant has traveled to the evaporator outlet, all of the liquid has "boiled" away and only a gas remains. The pressure exerted on the underside of diaphragm (B) is the boiling pressure of the refrigerant. This pressure can be found on the pressure-temperature chart for Refrigerant-12. The refrigerant boiling temperature can be determined from the chart. (See Chapter 17). Once all the liquid has boiled away in the evaporator, the low side pressure cannot go higher.

The refrigerant gas that leaves the outlet of the evaporator coil is at the same temperature and pressure as the saturated condition within the coil. This gas picks up sensible heat as it travels down the suction line toward the power element location, and the power element will now sense a higher temperature than the saturated temperature in the evaporator coil. This temperature at the bulb location, when converted to pressure within the bulb, will exert a force on top of diaphragm (B) greater than the saturated pressure beneath the diaphragm.

When the temperature at the bulb location becomes great enough, the pressure on top of diaphragm (B) will also be great enough to overcome both the saturation pressure and spring pressure beneath diaphragm (B) and the valve will open.

If the amount of refrigerant entering the evaporator coil is increased, this liquid will require more surface to "boil" away, and the point where all the liquid has turned to gas will actually extend further down the suction line.

The distance between the point where all the liquid has turned to gas and the bulb location is now decreased, so less sensible heat can be picked up and transmitted into bulb pressure. This decrease in pressure on top of diaphragm (B) will cause the valve to close slightly.



Fig. 19. Typical Expansion Valve

As the heat load increases, the liquid entering the evaporator coil will "boil" away quicker. This will increase the length of line that the suction gas has available to pick up additional heat that the power element senses. Thus, the valve will open farther and let in more liquid. A point of equilibrium is soon reached where the thermostatic expansion valve lets in just enough liquid refrigerant to keep the evaporator coil full of boiling refrigerant.

When the compressor stops, the evaporator and bulb temperature equalize, which cause the pressures above and below diaphragm (B) to equalize and spring (D) closes the valve.

The expansion valve setting in the power element and the closing spring pressure are factory set. Under normal circumstances, no attempt to change these settings should be made.

Inlet filtering screens are provided in most thermostatic expansion valves. They may be cleaned in the event the valve becomes clogged with foreign matter.

2. REMOVAL

- A. Discharge the refrigerant from the system.
- B. Disassemble unit to the point where the expansion valve and power element are accessible.
- C. Remove the insulation surrounding the power element. Loosen the power element from the clamp. Be sure that a note is made of the exact power element location.
- D. Using the proper combination of wrenches, remove the expansion valve from the unit. Do not twist or kink the connecting tube.
- E. Cap both inlet and outlet lines to prevent the entrance of moisture and foreign matter into the system.

3. INSTALLATION:

- A. Remove protecting caps and plugs from valve and connecting lines.
- B. Position the valve and tighten flare nuts finger tight.
- C. Tighten flare nuts using the proper combination of wrenches. Do not twist or kink the connecting tubes.
- D. Clamp the power element bulb securely in its proper location.
- E. Replace power element bulb insulation.
- F. Install new drier.
- G. Evacuate and recharge the system. (See Chapter 13.

4. TROUBLE SHOOTING:

When an automobile air conditioning system fails to operate properly, the expansion valve is often thought to be defective. As a matter of fact, failure of an expansion valve is rare. Many failures are due to improper

installation and service procedures. The expansion valve is one of the main components of a refrigeration system, and many problems with other parts of the system will show up as a malfunctioning expansion valve. This fact makes the expansion valve a key check-point in trouble shooting diagnosis. Following is a list of symptoms to aid the serviceman in diagnosing expansion valve problems.

SYMPTOM	PROBABLE CAUSE	DIAGNOSIS PROCEDURE
1. Hissing noise at expansion valve.	a. Shortage of refrigerant. b. Restriction in line.	a. Locate and repair leak; add refrigerant. b. Check receiver-drier for partial stoppage. Check lines and hoses for kinks. Check screen at expansion valve.
2. Partial frosting and sweating of coil, or poor cooling.	a. Expansion valve stuck in closed position. b. Power element bulb loose or in wrong location. c. Expansion valve inlet screen partially clogged.	a. Replace expansion valve. b. Reposition and secure tightly in place. c. Clean screen.
3. Failure to cool.	a. Expansion valve stuck in closed position. b. Expansion valve power element has lost its charge. c. Expansion valve inlet screen clogged. d. Expansion valve freeze-up	a. Replace expansion valve. b. Replace expansion valve. c. Clean screen. d. Replace drier, evacuate and recharge system.
4. High gauge reading on low side of system.	a. Over feeding of expansion valve due to poor bulb contact. b. Expansion valve stuck open.	a. Secure bulb tightly in proper location. b. Replace expansion valve.
5. Low gauge reading on low side of system.	a. Expansion valve stuck in closed position. b. Expansion valve freeze-up. c. Expansion valve screen clogged.	a. Replace expansion valve. b. Replace drier; evacuate, and recharge system. c. Clean screen.
6. Intermittent failure to cool.	a. Expansion valve freeze-up.	a. Replace drier; evacuate, and recharge system.

COMPRESSORS

1. GENERAL:

The compressor is the driving force of the automobile air conditioning system. It acts as a pump in the system and sucks and pushes the refrigerant gas through the system. One of the dividing points between the high and low pressures in the system is the valve plate of the compressor. Cool low pressure suction gas is pulled into the compressor, is compressed and discharged as high temperature, high pressure gas into the condenser.

The compressor is attached to the engine crankshaft through an electric clutch, drive pulley and belt arrangement, and any speed change in the engine reflects a comparable speed change in the compressor.

One of the requisites of a good automobile air conditioning system is rapid pull-down to a comfortable temperature when the driver enters a hot automobile. In order to accomplish this end at low engine speeds, the compressor must have the ability to pump large volumes of refrigerant. However, once the system is pulled down to normal temperature or the car is driven at highway speeds, the compressor has a greater capacity than normally required. These operating conditions in automotive air conditioning indicate that for the most part, the compressor has a much greater capacity than required, and an unbalanced system is a normal condition.

It is estimated that the average car owner living in an area which has a nine month air conditioning season, and driving 12,000 miles per year at an average speed of 35 mph would accumulate no more than 150 hours of actual compressor operation in one season. Compressor manufacturers normally test their compressor durability on the basis of 1,000 hours. This means that, if properly installed and serviced, an automotive air conditioning compressor should outlast the life span of several automobiles.

When designing a compressor, compressor manufacturer's major considerations are size, weight, serviceability, capacity, cost, and the ability to operate with minimum service and withstand clutch shock loads and vibration.

The compressor in widespread use today is a two cylinder reciprocating type with a basic design similar to an air compressor, with the exception of certain details which must be considered on refrigeration circuits.

Cool suction gas is pulled through the suction reeds or check valves in the valve plate assembly, and compressed and discharged through the discharge reeds or check valves on the piston upstroke. This continuous action of checking and compressing moves the refrigerant through the system and maintains high and low pressure differences across the compressor and in the system.

Service of the compressor in the field is usually limited to checking the oil and replacing the valve plate assembly, shaft seal and gaskets.

2. YORK COMPRESSORS:

a. General:

These compressors are constructed of light weight die-cast aluminum, and can be installed and operated in any position from horizontal left to horizontal right.

Four bosses on the seal end of the crankcase provide for mounting the standard clutch independent of the shaft seal plate. Smaller diameter clutches may be mounted on the seal plate surface.

All components are readily accessible and removable with standard tools.

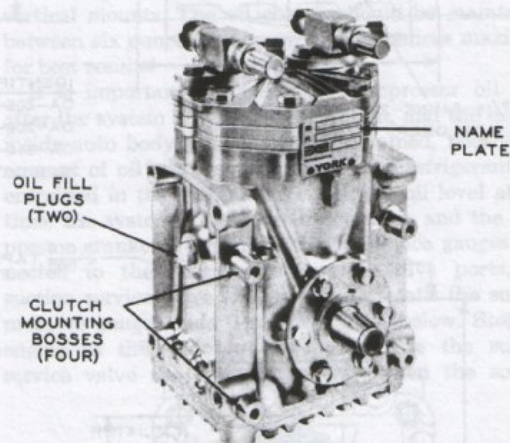

Fig. 20. York Compressor — Standard Service Valves

b. Identification:

The metal nameplate located at the top front of the compressor serves as a means of identification. The location permits viewing the nameplate with the clutch installed.

Data inscribed on the nameplate includes the serial number, combination model and part number, and designates the manufacturing period.

1. The serial number of Series 66 compressors has a "G" prefix.
2. Four clutch mounting bosses on crankshaft end.
3. Two oil fill plugs, one centered on each of the two horizontal mounting surfaces.

Models 206, 209 and 210 differ in the stroke and therefore in displacement. The various models may be identified by the difference in machining of the ends of the shaft. Refer to Fig. 21, Detail A.

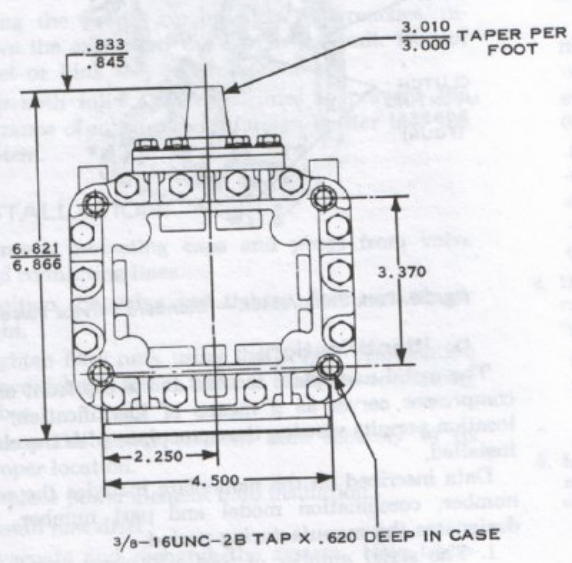
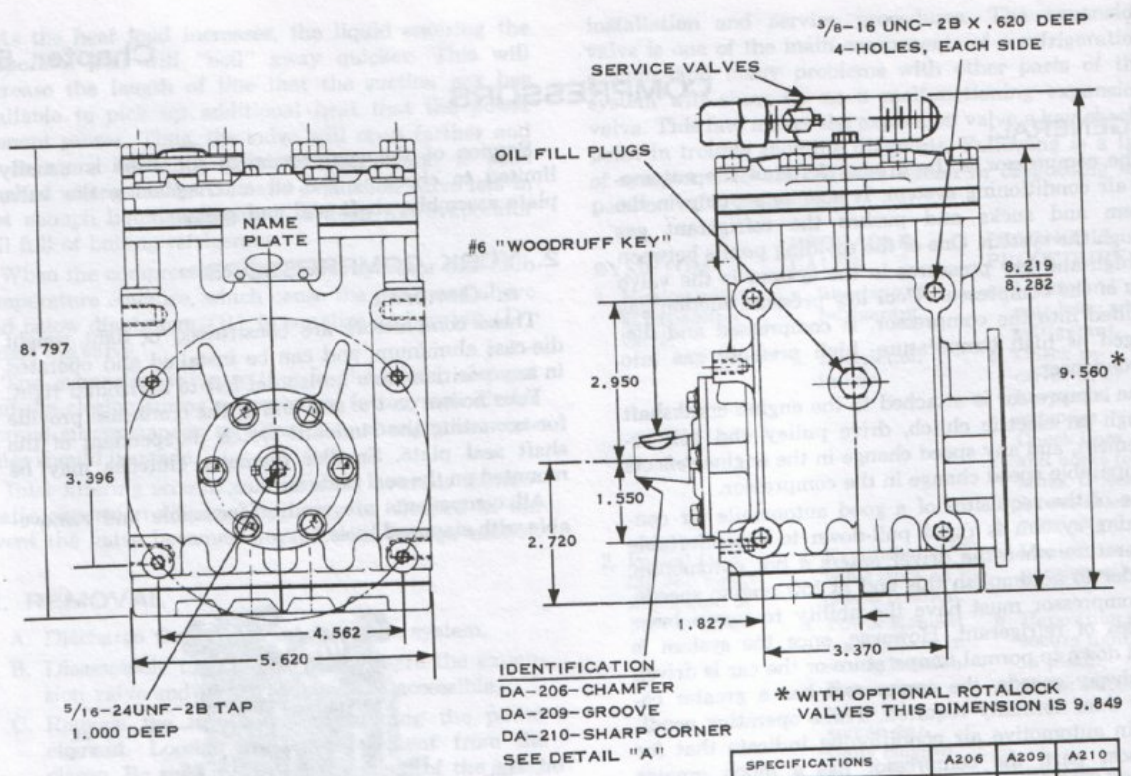

SPECIFICATIONS	A206	A209	A210
NO. CYLINDER	2	2	2
BORE, INCHES	1.875	1.875	1.875
STROKE, INCHES	1.105	1.573	1.810
DISP., IN. 3/REV.	6.11	8.7	10.0
R. P. M. - MAX.	6000	6000	6000
REFRIGERANT	12	12	12
INITIAL OIL CHG., OZ.	10	10	10
WEIGHT, LBS. †	14.6	14.6	14.6
LUBRICATION	POSITIVE PRESSURE		

† WITH VALVES AND OIL CHARGE.

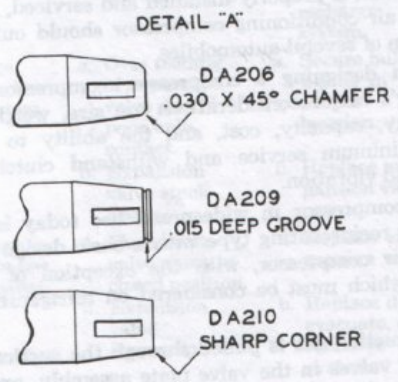
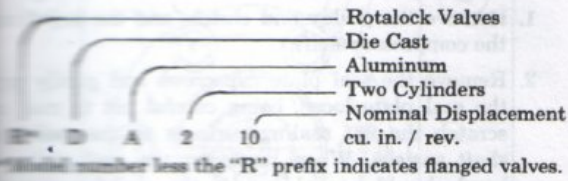
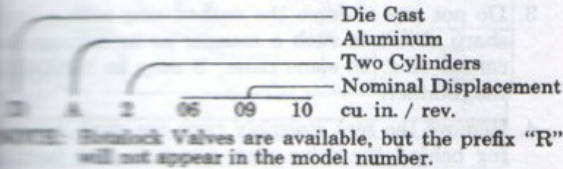

Fig. 21. York Compressors — Dimensions and Specifications

SERIES 63



SERIES 64, 65, 66



c. Dimension and Physical Data:
See Fig. 21

d. Oil Charge:

The compressor oil level should be checked at the time of installation and again after the system has been fully charged with refrigerant, and system has been operated and balanced out to the desired automobile interior temperature.

All compressors are factory charged with 5/8 pint (1 1/4 ounces) of "Suniso" No. 5 or "Texaco" Capella 30 grade 300 viscosity oil. Only these or equivalent oils should be used when adding or changing oil.

Make the initial oil check after the compressor is mounted on the mounting bracket, and before initial operation.

Remove one oil fill plug with its "O" ring, either way on a vertical mount installation, the upper plug whether than vertical mount installations.

Fig. 22 shows the details of an oil dip stick which can be made locally, and which is suitable for use on all series compressors in any mounting position. The dip stick can be formed from 1/8" dia. x 8-5/16" long stock, preferably non ferrous material which is not subject to corrosion. Notched ends are helpful in visibly showing the oil depth.

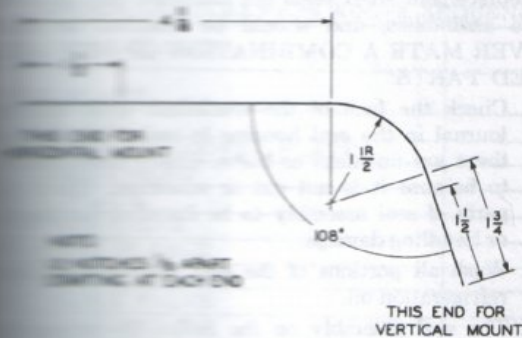

Fig. 22. Oil Dip Stick

The oil level should be checked with the keyway in the shaft positioned to face the head of the compressor. This places the throws of the crankshaft into most favorable position for passage of the dip stick.

If the position of the keyway cannot be determined with the clutch mounted, the crank position can be determined by feel and the dip stick inserted so that the oil level is measured from the lowest point in the crankcase.

Note from Fig. 22 that the long leg of the dip stick is used for checking oil level in horizontal mounts, and the short leg for vertical mounts.

Table 2. Oil Charge vs Dip Stick Length

Oil Charge, Ounces	6	8	10
Horizontal Mount	1 3/16"	1"	1 3/16"
Vertical Mount	7/8"	1"	1 1/8"

Table 2 shows the crankcase oil charge in ounces at various dip stick measurements for both horizontal and vertical mounts. The oil charge should be maintained between six ounces minimum and 10 ounces maximum for best results.

It is important to check the compressor oil level after the system has been in operation, and the desired inside auto body temperature is obtained, because an amount of oil will be absorbed by the refrigerant and entrained in the system. To check the oil level at this time, the system should be in operation and the compressor crankcase warm. With the service gauges connected to the compressor service valve ports, the suction service valve is slowly closed until the suction pressure gauge reads 0 psi or a little below. Stop the engine at this point and quickly close the suction service valve the rest of the way when the suction

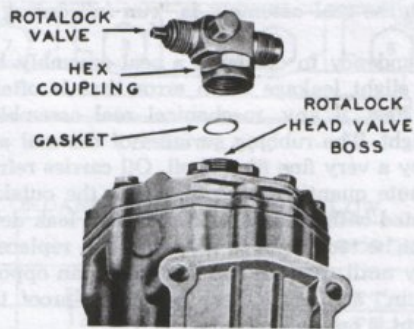
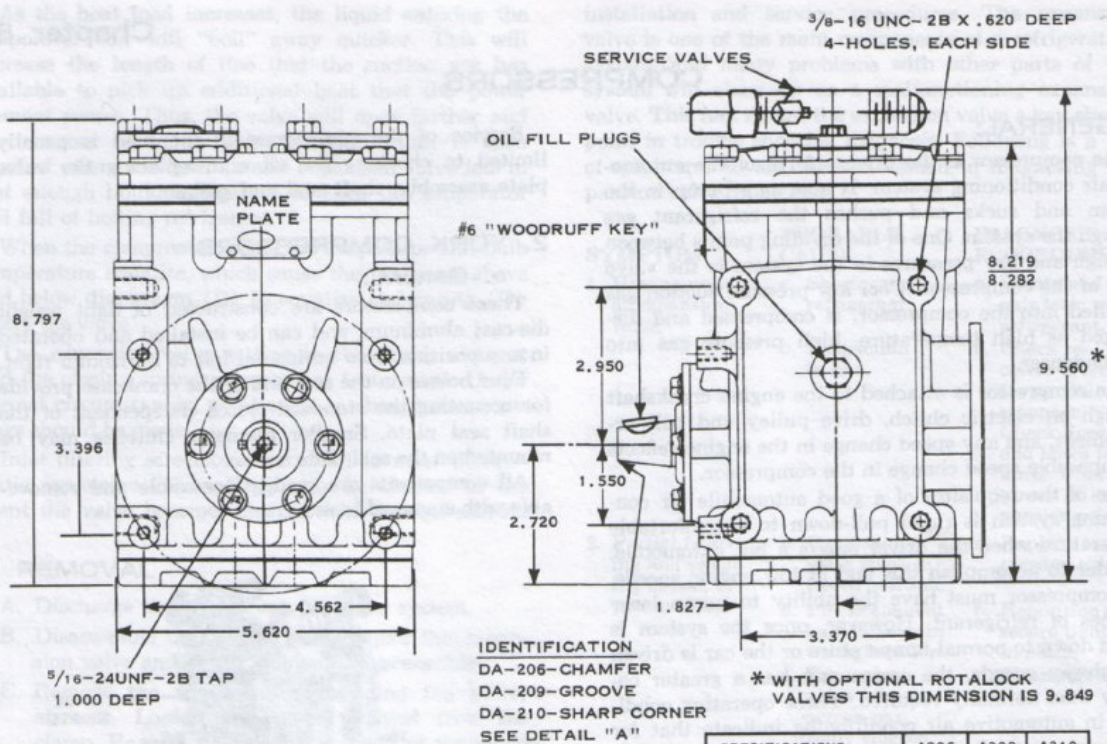

Fig. 23. York Compressor — Rotalock Service Valves

gauge reads a little above 0 psi. Close the discharge service valve. It is important that the suction service valve be closed slowly when pumping the system down, because an abnormal amount of oil may leave the compressor due to the sudden pressure reduction on the refrigerant saturated oil in the compressor crankcase. After both service valves are closed, the suction



SPECIFICATIONS	A206	A209	A210
NO. CYLINDER	2	2	2
BORE, INCHES	1.875	1.875	1.875
STROKE, INCHES	1.105	1.573	1.810
DISP., IN. ³ /REV.	6.11	8.7	10.0
R, P, M. - MAX.	6000	6000	6000
REFRIGERANT	12	12	12
INITIAL OIL CHG., OZ.	10	10	10
WEIGHT, LBS.†	14.6	14.6	14.6
LUBRICATION	POSITIVE PRESSURE		

† WITH VALVES AND OIL CHARGE.

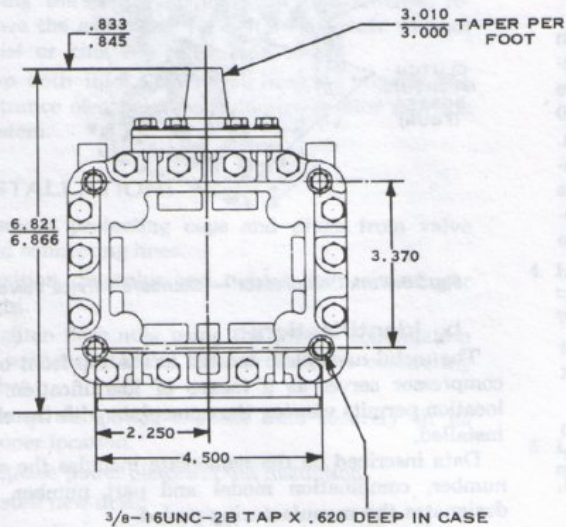

DETAIL "A"

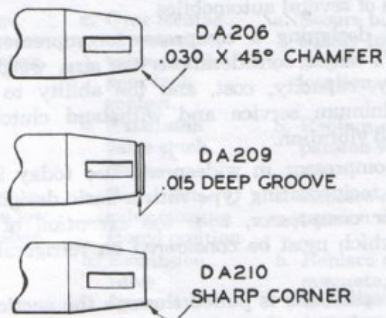

Fig. 21. York Compressors — Dimensions and Specifications

DEEP
E

9.560*

9.849

A210
2
1.875
1.810
10.0
6000
12
10
14.6
ESSURE

MFER

E

ER

SERIES 63

- Rotalock Valves
- Die Cast
- Aluminum
- Two Cylinders
- Nominal Displacement cu. in. / rev.

*Model number less the "R" prefix indicates flanged valves.

SERIES 64, 65, 66

- Die Cast
- Aluminum
- Two Cylinders
- Nominal Displacement cu. in. / rev.

NOTE: Rotalock Valves are available, but the prefix "R" will not appear in the model number.

c. Dimension and Physical Data:

See Fig. 21

d. Oil Charge:

The compressor oil level should be checked at the time of installation and again after the system has been fully charged with refrigerant, and system has been operated and balanced out to the desired automobile exterior temperature.

All compressors are factory charged with 5/8 pint (10 ounces) of "Suniso" No. 5 or "Texaco" Capella "2" grade, 500 viscosity oil. Only these or equivalent oils should be used when adding or changing oil.

Make the initial oil check after the compressor is mounted on the mounting bracket, and before initial operation.

Remove one oil fill plug with its "O" ring, either using on a vertical mount installation, the upper plug or on other than vertical mount installations.

Fig. 22 shows the details of an oil dip stick which can be made locally, and which is suitable for use on all series compressors in any mounting position. The dip stick can be formed from 1/8" dia. x 8-5/16" long stock, preferably non ferrous material which is not subject to corrosion. Notched ends are helpful in visibly indicating the oil depth.

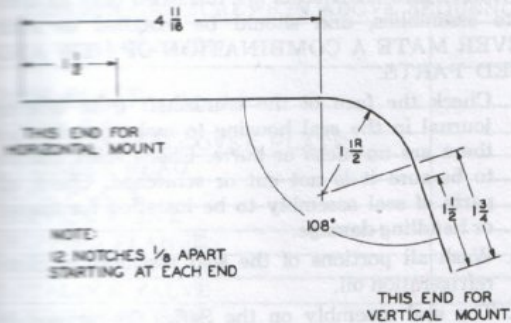

Fig. 22. Oil Dip Stick

The oil level should be checked with the keyway in the shaft positioned to face the head of the compressor. This places the throws of the crankshaft into most favorable position for passage of the dip stick.

If the position of the keyway cannot be determined with the clutch mounted, the crank position can be determined by feel and the dip stick inserted so that the oil level is measured from the lowest point in the crankcase.

Note from Fig. 22 that the long leg of the dip stick is used for checking oil level in horizontal mounts, and the short leg for vertical mounts.

Table 2. Oil Charge vs Dip Stick Length

Oil Charge, Ounces	6	8	10
Horizontal Mount	1 3/16"	1"	1 1/16"
Vertical Mount	7/8"	1"	1 1/8"

Table 2 shows the crankcase oil charge in ounces at various dip stick measurements for both horizontal and vertical mounts. The oil charge should be maintained between six ounces minimum and 10 ounces maximum for best results.

It is important to check the compressor oil level after the system has been in operation, and the desired inside auto body temperature is obtained, because an amount of oil will be absorbed by the refrigerant and entrained in the system. To check the oil level at this time, the system should be in operation and the compressor crankcase warm. With the service gauges connected to the compressor service valve ports, the suction service valve is slowly closed until the suction pressure gauge reads 0 psi or a little below. Stop the engine at this point and quickly close the suction service valve the rest of the way when the suction

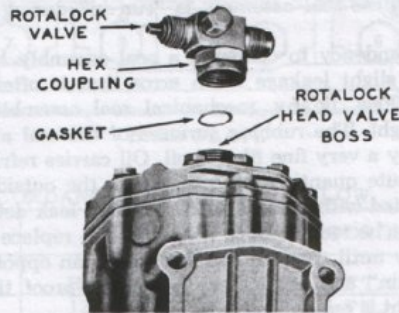

Fig. 23. York Compressor — Rotalock Service Valves

gauge reads a little above 0 psi. Close the discharge service valve. It is important that the suction service valve be closed slowly when pumping the system down, because an abnormal amount of oil may leave the compressor due to the sudden pressure reduction on the refrigerant saturated oil in the compressor crankcase. After both service valves are closed, the suction

pressure will slowly rise to about 5 lbs. gauge pressure. The remaining pressure in the compressor is then released by unscrewing the oil check plug five full turns and bleeding the pressure off until the gauge reads 0 psi. Next, completely remove the oil check plug and "O" ring and determine the oil level as outlined in the preceding paragraph. The oil depth obtained on the dip stick should be approximately the required depth for the compressor mounting position shown on the Oil Charge Chart, Table 2.

The compressor oil level should never be permitted to go below the minimum oil level shown on the Oil Charge Chart for the mounting position used. If oil must be added, the oil level should not exceed the initial charge depth, because an excessive amount of oil is detrimental to the proper functioning of the entire system. The oil level should be checked prior to putting the system into operation at the beginning of each season.

When inserting the oil fill plug, the sealing "O" ring is slipped over the oil fill plug threads in such a manner that the "O" ring is not twisted. Insert the oil plug in the oil fill opening and tighten the plug. If the plug leaks, do not attempt to stop the leak by over-tightening the oil check plug. A leak may be caused by dirt under the "O" ring or on the seat, a fractured "O" ring, or a damaged seat on the oil fill plug or oil fill opening. To stop leaks at the oil fill plug, correct the mechanical damages and insert a new "O" ring.

It must be remembered that the 206, 209 and 210 Models are high speed compressors and satisfactory operation depends on proper lubrication.

e. Shaft Seal Assembly:

The shaft seal assembly of the York Automotive Compressor is easily and quickly replaced. Seals are machined to 2 helium light bands of flatness. The carbon is lapped to the steel, and the fit becomes even better as the seal assembly is "run in" during operation.

The tendency to condemn a seal assembly because of very slight leakage is an error that is often committed. Few, if any, mechanical seal assemblies are 100% tight. The rubbing surfaces of the seal are separated by a very fine film of oil. Oil carries refrigerant and minute quantities which seep to the outside may be detected with modern ultra sensitive leak detectors.

Do not be too prone to condemn and replace a seal assembly until the seal has been given an opportunity to "run in" and until there is definite proof that replacement is really necessary.

f. Shaft Seal Assembly Servicing:

When servicing the shaft seal, extreme care must be taken when removing or installing the parts to prevent damage to the lapped surfaces and other seal parts. The portion of the shaft on which the seal assembly fits must be free of scratches, burrs, and dirt and the entire seal housing cavity must be clean. Use a piece of lint free cloth as a wiper.

g. Seal Assembly — Removal:

1. Remove the pulley and clutch, and the key from the compressor shaft.
2. Remove the seal plate capscrews and gently pry the seal plate loose, being careful not to mar or scratch the flat sealing surfaces or the polished shaft surface. When removing the seal plate, a hand should be held under the seal housing to catch the carbon ring if it is free.
3. Do not pry or force the carbon ring with a hard sharp object in such a manner as to damage the carbon ring. In some cases, it may be bonded to the retainer.
4. Remove the seal assembly from the shaft by prying behind the drive ring, which is that portion of the seal assembly farthest back on the shaft. When prying the seal assembly from the shaft, do not scratch or burr the crankshaft or the seal housing face on the crankcase.

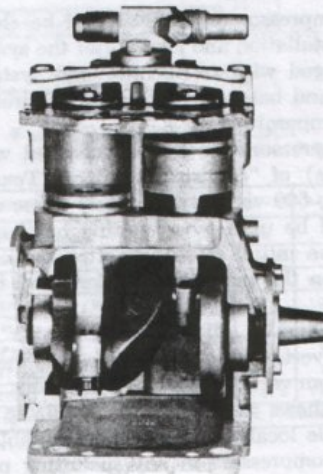
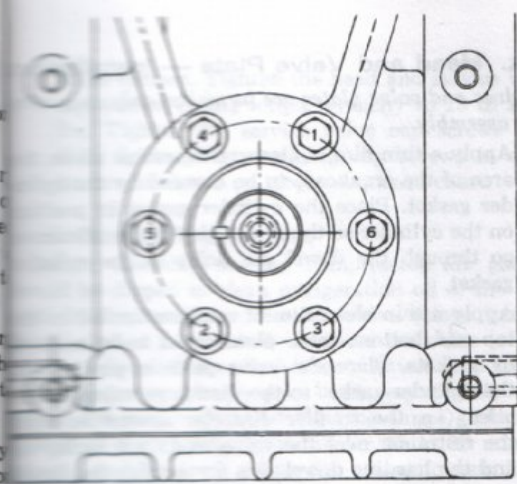

Fig. 24. York Compressor — Cut-Away View

h. Seal Assembly — Installation:

Replacement shaft seals are furnished only as complete assemblies, and should be installed as such. NEVER MATE A COMBINATION OF NEW AND USED PARTS.

1. Check the face of the crankshaft front bearing journal in the seal housing to make certain that there are no nicks or burrs. Check shaft surface to be sure it is not cut or scratched. Check all parts of seal assembly to be installed for transit or handling damage.
2. Wash all portions of the seal assembly in clean refrigeration oil.
3. The seal assembly on the Series 66 compressor uses a quad ring inserted into a groove in the seal housing. The new replacement seal assembly suit-



SHAFT SEAL PLATE

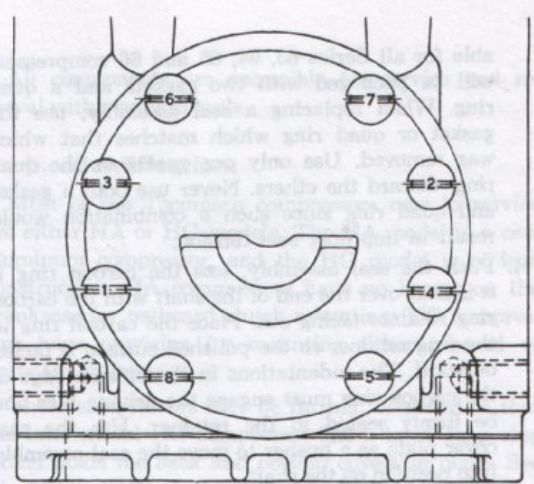

REAR BEARING COVER PLATE

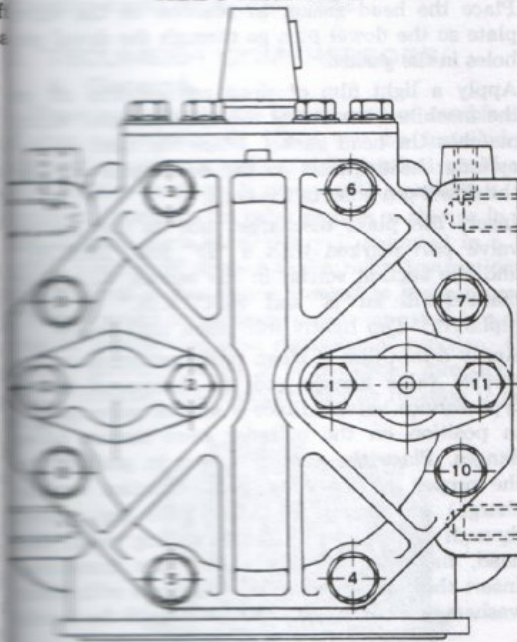

CYLINDER HEAD, STANDARD OR ROTALOCK

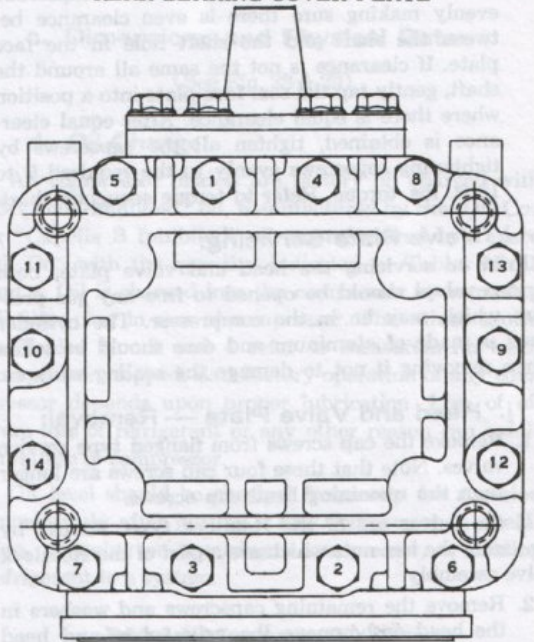

BASE PLATE

TIGHTEN CAP SCREWS IN ABOVE SEQUENCE AND IN ACCORDANCE WITH TABLE BELOW

LOCATION	THREAD	HEAD TYPE	TORQUE
BASE PLATE	1/4-20UNC	HEX	14-22 FT. LBS.
COVER BCD	1/4-20UNC	12PT.	13-16 FT. LBS.
REAR BEARING COVER PLATE	1/4-20UNC	FLAT	9-17 FT. LBS.
CYLINDER HEAD	5/16-18UNC	HEX	15-23 FT. LBS.
SEAL PLATE	1/4-20UNC	HEX	7-13 FT. LBS.
SERVICE VALVE	5/16-18UNC	HEX	8-13 FT. LBS.
SHIPPING FLANGE	5/16-18UNC	HEX	8-13 FT. LBS.
SEAL CAP	1-14 NS	ROUND	7-10 FT. LBS.
ROTALOCK VALVE	1-14 NS	HEX	30-35 FT. LBS.
SHIPPING SCREW	3/8-16UNC	USERS CHOICE	14-17 FT. LBS.
SEAL FILL PLUG	3/8-14UNF	HEX	2-6 FT. LBS.

Fig. 25. York Compressor — Torque Sequence Chart

able for all Series 63, 64, 65 and 66 compressors will be packaged with two gaskets and a quad ring. When replacing a seal assembly, use the gasket or quad ring which matches that which was removed. Use only one gasket or the quad ring, discard the others. Never use both a gasket and quad ring since such a combination would result in improper seal tension.

4. Push the seal assembly, less the carbon ring if it is free, over the end of the shaft with the carbon ring retainer facing out. Place the carbon ring in the ring retainer so the polished surface is facing outward. The indentations in the outside edge of the carbon ring must engage the driving lugs and be firmly seated in the retainer. Use the seal cover plate as a pusher to move the seal assembly into position on the shaft.
5. Insert the capscrews. Turn in the capscrews evenly making sure there is even clearance between the shaft and the shaft hole in the face plate. If clearance is not the same all around the shaft, gently tap the seal face plate into a position where there is equal clearance. After equal clearance is obtained, tighten all the capscrews by tightening capscrews evenly to the required 7 to 13 ft. lbs. torque. Refer to torque sequence chart.

i. Valve Plate Servicing:

Prior to servicing the head and valve plate, both service valves should be opened to free any gas pressure which may be in the compressor. The cylinder head is made of aluminum and care should be taken when removing it not to damage the sealing surfaces.

j. Head and Valve Plate — Removal:

1. Remove the cap screws from flanged type service valves. Note that these four cap screws are longer than the remaining head cap screws.

If the valves are of the Rotalock type, remove by loosening the hex nuts which are a part of the Rotalock valve assembly.

2. Remove the remaining capscrews and washers in the head and remove the valve plate and head from the cylinder by prying or tapping under the ears, which extend from the valve plate. If the head and valve plate adhere, hold the head and tap the valve plate ears away from the head with a soft hammer. Do not hit or tap the head to separate the head and valve plate because damage to the head may result.
3. If it is necessary to replace the discharge tube, or the suction screen assembly, remove the old discharge tube or suction screen from the service valve ports in the head by forcing them the entire length up through the head and out the top, which is the larger end of the tapered ports.
4. All gasket material adhering to the head, valve plate, or cylinder should be carefully removed in such a manner that the machined sealing surfaces are not scratched or nicked.

k. Head and Valve Plate — Installation:

Valves and valve plates are furnished only as a complete assembly.

1. Apply a thin film of clean refrigeration oil on the area of the crankcase to be covered by the cylinder gasket. Place the cylinder gasket in position on the cylinder so the dowel pins in the crankcase go through the dowel pin holes in the cylinder gasket.
2. Apply a thin clean film of refrigeration oil to the top and bottom valve plate areas to be covered by gaskets. Place the valve plate in position on the cylinder gasket so the discharge valve assemblies (i.e. the smaller diameter assemblies with the restrainer over the valve reed) are facing up and the locating dowel pins go through the dowel pin holes in the valve plate.
3. Place the head gasket in position on the valve plate so the dowel pins go through the dowel pin holes in the gasket.
4. Apply a light film of clean refrigeration oil on the machined surface of the cylinder head which matches the head gasket. Place the head on the cylinder head gasket so the dowel pins go into the dowel pin holes in the head.
5. Insert the plain discharge tube in the service valve port marked with a "D" and "DISCH," and the suction screen in the service valve port marked with an "S" and "SUCTION." (If being replaced.) Tap lightly into place until flush.
6. Apply a thin film of clean refrigeration oil to the service valve flanges and the flanges of flange type service valves. Place a service valve gasket in position on the cylinder head service valve flanges. Place the service valves in position on the proper service valve ports (suction or discharge) and insert the four longer cap screws through the service valve mounting pads, the head, the valve plate, and into the crankcase. Insert the remaining head cap screws with their washers and run in all cap screws until the heads

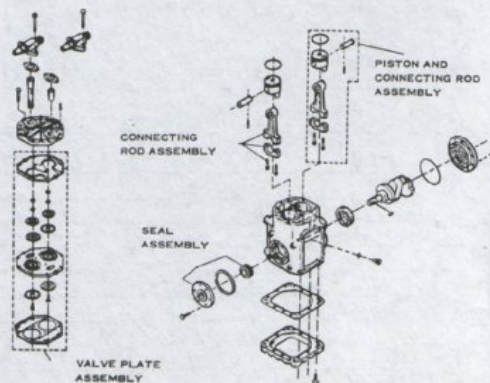

Fig. 26. York Compressor — Exploded View

make contact. Tighten the head and service valve cap screws (using torque wrench) to 15 to 23 ft. lbs. Tighten the service valve cap screws first, then tighten the remaining cap screws in a sequence as shown on torque sequence chart.

I. Gasket Treatment:

Before assembly to the compressor, all gaskets should be dipped in clean refrigeration oil of the type used in the crankcase. Service valve flange gaskets should always be replaced whenever the valve is loosened or relocated from its former position. The service valve flanges tend to warp or bend very slightly after use, and it is recommended that the flange gaskets be soaked in clean refrigeration oil for 15 to 30 minutes prior to use. This will soften the gasket to permit the valve to seat properly and the gasket to seal without excessive torque on the cap screws.

3. TECUMSEH COMPRESSORS:

a. General:

These compressors are constructed of combinations of iron and aluminum. They can be installed and operated in either a horizontal or vertical position, or any position midway between with crankshaft in a horizontal position. On older models, a change in location of some parts is necessary if mounted in a horizontal position 90 degrees to the right. Instructions for making such a change are secured to the compressor.

Newer model compressors can be operated in a clockwise or counterclockwise direction of rotation. Older models normally rotate in a clockwise direction, but can be modified for counterclockwise rotation if necessary.

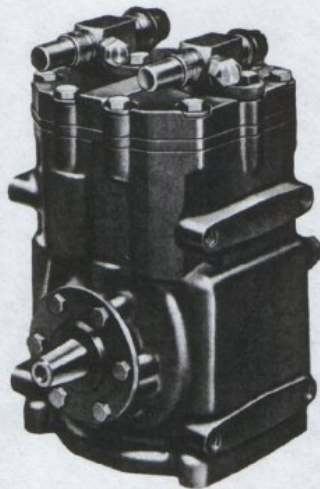

Fig. 27. Tecumseh HG Compressor

On later models bosses are provided on the seal end of the crankcase for clutch mounting, and smaller diameter clutches may be mounted on the plate surface. Older model compressors have only provision for mounting clutches on the seal plate surface.

All components are accessible for service and removal with standard tools.

b. Identification:

Most of the Tecumseh compressors now in service are either HA or HG models. The HA model is a cast aluminum compressor, and the HG model is of iron construction. HA compressors have no bosses on the crankcase for outboard clutch mounting; HG compressors have provision for mounting either inboard or outboard clutches.

These compressors may be further identified in that the later model HG compressor has a large snap ring which holds the back and bottom covers in place. See Fig. 30.

c. Dimensions and Physical Data:

(See Fig. 28 & 29)

d. Oil Charge:

All compressor models are factory oil charged with "3G Dual-inhibited" oil, manufactured by Sun Oil Co., or "Capella B Inhibited" oil, manufactured by Texaco Oil Co., with the quantity indicated in Tables No. 3 and 4. Oil is charged into the compressor by removing oil filler plug in rear of compressor. The values shown in Tables No. 3 and 4 refer to measurements with compressor stopped. Satisfactory operation of any compressor depends upon proper lubrication. Loss of oil from loss of refrigerant or any other reason can result in failure of compressor.

Oil level should be checked frequently for a period immediately after putting a new compressor in operation, changing or repairing a compressor, or adding refrigerant to a system.

Table 3. HA Compressor Oil Charge

Compressor Position	Oil Height	Remarks
Vertical	1 $\frac{3}{8}$ "	Factory Charge of 10 oz.
Horizontal Left	1 $\frac{1}{16}$ "	Factory Charge of 10 oz.
Horizontal Right	1 $\frac{1}{16}$ "	Factory Charge of 10 oz.
Vertical	$\frac{3}{4}$ "	Max. Recommended Height*
Vertical	1 $\frac{1}{4}$ "	Max. Recommended Height*
Horizontal Left	$\frac{3}{4}$ "	Max. Recommended Height*
Horizontal Left	1 $\frac{1}{4}$ "	Min. Recommended Height*
Horizontal Right	$\frac{3}{4}$ "	Min. Recommended Height*
Horizontal Right	1 $\frac{1}{4}$ "	Min. Recommended Height*

* After connected to system and run.

NOTE: Horizontal position refers to compressor position as rotated 90° to right or left of vertical as viewed from shaft end of compressor.

Table 4. HG Compressor Oil Charge

Compressor Position	Oil Height HG	Remarks
Vertical	1 $\frac{5}{16}$ "	Factory charge of 11 fluid oz.
°Horizontal	1 $\frac{5}{16}$ "	Factory charge of 11 fluid oz.
Vertical	$\frac{7}{8}$ "	Min. recommended height*
Vertical	1 $\frac{3}{8}$ "	Max. recommended height*
°Horizontal	$\frac{7}{8}$ "	Min. recommended height*
°Horizontal	1 $\frac{3}{8}$ "	Max. recommended height*

*After connected to system and run.

°NOTE: Horizontal position refers to compressor position as rotated 90° to right or left of vertical as viewed from shaft end of compressor.

Oil level can be checked by removing plug in oil fill hole in rear of compressor, and inserting a dip stick through it to bottom of crankcase and measuring the vertical height of stick wetted with oil. When checking the oil level, do it after compressor has been in operation for a sufficient time to warm compressor so as to reduce the amount of refrigerant dissolved in the oil. Preparatory to checking oil level, install suction gauge and with compressor running at reduced speed, close suction valve. When a suction pressure of 2 lbs. is reached, stop compressor and immediately close discharge service valve. Under this condition, oil plug can be removed with a minimum loss of refrigerant and still not introduce air or moisture in system.

e. Shaft Seal Assembly:

This assembly includes front seal plate, seal nose and spring assembly, and "O" ring for front seal plate.

1. Reduce pressure in compressor.
2. Wash or clean seal plate and adjoining surfaces of all dirt and foreign material.
3. Remove seal plate nose assembly by removing the six bolts in plate and gently pry plate loose, being careful not to scratch, mar or nick crankcase mating surface or edges.
4. Remove carbon nose and spring assembly from shaft by prying behind the drive ring, which is that portion of seal assembly farthest back on the shaft. When prying the seal assembly from shaft, do not scratch crankshaft. If rubber seal around shaft does not come out with carbon nose and spring assembly, remove same with long nose pliers pulling on edge of grommet.
5. Remove all dirt and foreign material from crankcase mating surface to seal plate, exposed crankshaft and adjacent surfaces.

6. Remove new shaft seal washer from bellows seal assembly. Coat the exposed surface of crankshaft with clean refrigeration oil. Dip new bellows seal assembly and shaft seal washer in clean refrigeration oil. Place bellows seal assembly over shaft with end for holding shaft seal washer going on last. Push bellows seal assembly by hand on shaft to a position beyond taper of shaft.

Table 5. Tecumseh Compressor — Bolt Torque Requirements

Location	Torque
Cylinder Head	20-24 ft. lbs.
Service Valve — Hex Head	20-24 ft. lbs.
Service Valve — 12 point Socket Head	20-24 ft. lbs.
Service Valve — Socket Head	20-24 ft. lbs.
Crankshaft End	15-20 ft. lbs.
Seal Plate	6-10 ft. lbs.
Rear Bearing Housing Cover Plate	10-14 ft. lbs.
Bottom Plate	20-24 ft. lbs.
Mounting	14-17 ft. lbs.
Front Bearing Lock Bolts	- 6 ft. lbs.
Connecting Rod	- 7 ft. lbs.
Oil Filler Plug	18-22 ft. lbs.

7. Assemble shaft seal washer in bellows seal assembly, checking before doing so to see that bellows seal assembly and shaft are free from dirt and foreign material. Assemble seal washer so that raised rim is away from bellows seal assembly, and that the notches in washer line up with the nibs in bellows seal assembly. Cover exposed surface of shaft seal washer with clean refrigeration oil.
8. Insert new rectangular-section "O" ring in crankcase mating surface for seal plate.
9. Place new front seal plate over shaft. Properly line up mounting holes. With hand on each side of front seal plate, push plate up against crankcase. Insert the six cap screws in circular sequence to torque specified on Table 5.
10. Rotate shaft by hand 15 to 20 revolutions to seat seal.

f. Valve Plate Servicing:

Parts Required: Specified Valve Plate Kit

This assembly includes the valve plate, discharge valve, suction valves, valve retainer parts and valve plate and cylinder head gaskets.

In most compressor installations, these assemblies can be replaced without removing the compressor. To make this replacement, procedure is as follows:

cate it over cylinder head gasket so that side of head which has the word "Suction" is up and on the same side as the word "Suction" on front of crankcase, and that its holes line up with those in gaskets, valve plate and cylinder.

f. Insert bolts (12 with Rotalock valve and 8 with pad-type) for mounting cylinder head and valve plate into cylinder head and valve plate holes and tighten in a sequence so that bolts diagonally opposite each other are evenly drawn to the torque limits.

9. a. Rotalock Type Service Valve:
Inspect top of ports to see that they are free from nicks or imperfections and that fiber washer is not damaged and is properly positioned. Connect service valves to correct ports and tighten to a torque of 65 to 70 ft. lbs.

b. Pad-base Mounted Valve:
Insert bolts through mounting holes. Take new service valve gaskets and insert valve mounting bolts through them and properly locate valve over service valve ports. Tighten bolts to torque specified.

10. After a period of two hours from time of assembly of the valve plate, retorque the cylinder head (and service valve of pad-type) to torque limit specified.

4. GENERAL MOTORS COMPRESSORS:

a. General:

The GM 6-cylinder compressor is used only on GM factory installations. The swash plate, or "wobble" plate on these compressors drives three double-headed pistons back and forth in the housing to compress the refrigerant vapor. See Fig. 32.

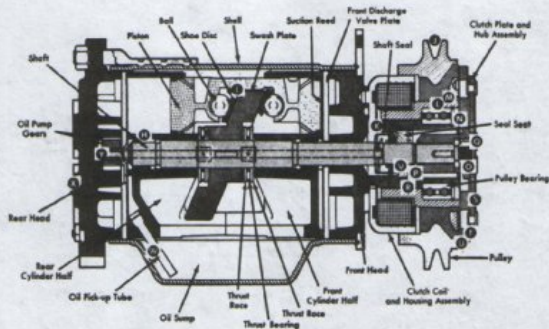

Fig. 32. Cross Section — GM Six-Cylinder Compressor

b. Identification:

There are five basic models used on GM products. The 1955 model has a large bolt flange at rear of case, a schrader valve oil check and a splined shaft. The 56-57 model also has a large bolt flange at rear of case, but has a 7/16" cap screw check plug and a smooth press fit shaft.

The 1958 model has a small ridge around the front of the coil housing, and the shaft has three stages. The first stage has a woodruff keyway, the second stage is smooth and 3/4" long, and the third stage is threaded for a nut.

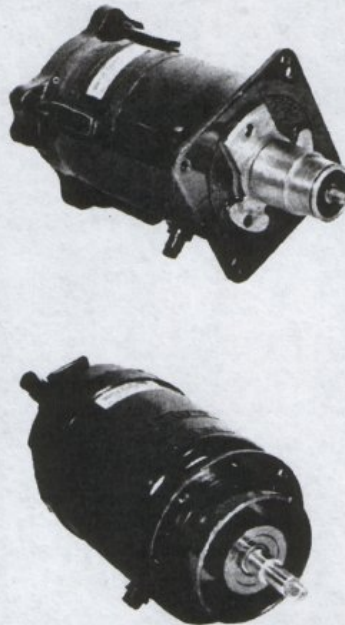

Fig. 33. GM Compressors

The 59-60-61 models have no ridge around the front of the coil housing, but does have a three stage shaft. The second stage is one inch long. The 59-60-61 compressor can replace the 58 model by using a 1/4" spacer between the clutch and the shaft nut.

The 62 through 66 compressor is identified by four bolts welded to the rear of the case and used to bolt the rear head in place. While this compressor is often used to replace 58 through 61 models, the change requires a new clutch.

c. Oil Charge:

Compressors are originally charged with 10 oz. of Special Frigidaire 525 viscosity refrigeration oil. Design and configuration of the six cylinder compressor require a radical departure from the oil checking procedure used on conventional compressors.

In the GM compressor it is not recommended that the oil be checked as a matter of course. Generally, compressor oil level should be checked only when there is evidence of a major loss of system oil.

To check the compressor oil charge, it is necessary to remove the compressor from the vehicle, then drain and measure the oil. Construction of a funnel with a

threaded connection to fit the oil fitting on the compressor will greatly simplify servicing of a compressor with oil.

d. Shaft Seal Assembly:

Removal:

1. After first purging the system of refrigerant, remove the clutch hub and drive plate, and the shaft key.



Fig. 34. Removing Seal Seat Retaining Snap Ring

2. Remove the seal seat retaining ring using snap ring pliers.
3. Using Tool 07-20018, grasp the flange on the seal seat and lift out the seal seat.



Fig. 35. Seal Seat Remover and Installer — 07-20018

4. Remove the seal seat "O" ring from the housing bore using Tool 07-20019.



Fig. 36. "O" Ring Remover — 07-20019

5. Engage the tabs on the seal assembly with the locking tangs on Tool 07-20014 by pressing down and twisting the tool, then lift the seal out.



Fig. 37. Seal Assembly Remover and Installer — 07-20014

Inspection:

Check the face of the seal for nicks, gouges or serrations. If damage of any kind is evident, replace the seal. Be extremely careful that the face of the seal which is to be installed is not scratched or damaged in any way.

Installation:

1. Engage seal onto the locking tangs of Tool 07-20014 and carefully insert the seal and tool over the end of the shaft. Turn seal to engage the flat on the shaft, then remove the tool.
2. Coat a new "O" ring and the interior of the seal cavity, shaft and seal with clean refrigeration oil, and install it in its groove just above the seal.
3. Using Tool 07-20018, grasp the seal seat and set in place on top of the seal.
4. Using Tool 07-20021, replace the retaining ring.
5. Reinstall the clutch hub and drive plate.
6. Replace the compressor on the vehicle, if it was previously removed, and evacuate and charge the system.



Fig. 38. "O" Ring Installer — 07-20020



Fig. 39. Snap Ring Installer — 07-20021

Part No.	Tool Name
07-20012	GM Clutch Clutch Pulley Puller
07-20013	GM Bearing Remover And Installer
07-20014	GM Seal Remover And Installer
07-20015	GM Clutch Plate Remover
07-20016	GM Clutch Plate And Pulley Installer
07-20017	GM Seal Protector
07-20018	Tongs (GM Seat Remover & Installer)
07-20019	O Ring Remover
07-20020	O Ring Installer
07-20021	Snap Ring Installer

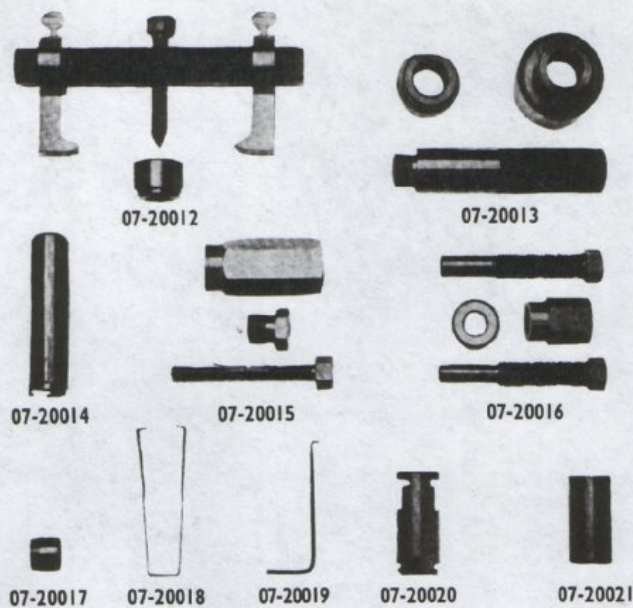

Fig. 40. Frigiking GM Compressor Tool Set — 07-90018

5. CHRYSLER:

a. General:

The compressor used in Chrysler factory installation is a "V" type, two cylinder cast iron compressor.

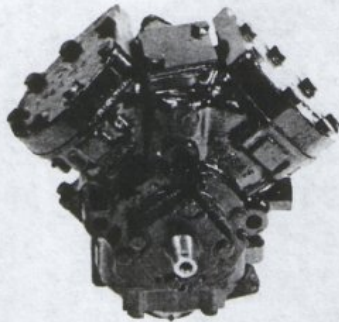

Fig. 41. Chrysler Compressor

b. Identification:

Four models have been used since 1957. They are all of the same basic design with small modifications.

The 1957-58 model has a slanted cast iron oil sump and a rounded shaft seal plate outer surface.

The 1959-60 and 1961 through 1965 models all have a rounded steel oil sump with an oil plug.

1959 models have a shaft seal plate of the design as the 1957-58 models, but with the steel oil sump.

On 1960 and 1961 through 66 models, the shaft seal plate surface is machined and has three tappings to mount the clutch field assembly.

The 1961-66 models are identified from the 1960 models in that a service valve is located on the crankcase on the crankshaft side.

c. Specifications:

Table 6. Chrysler Compressor Specifications

Type	2 Cylinder "V" Type
Bore	2 $\frac{5}{16}$ inch
Stroke	1 $\frac{1}{8}$ inch
Displacement	9.45 cubic inches
Type Valve	Reed Type
Speed (depends on axle ratio and tire size)	Approximately 1250 rpm at 25 mph
Oil Capacity (Refrigerant Oil)	11 ounces
Clutch	Stationary Coil
Mufflers	In Compressor Discharge Line In Compressor and Suction Line

d. Shaft Seal:

1. Remove crankshaft housing seal bolts.
2. Remove bearing housing from case, using two screwdrivers inserted in slots provided to pry housing from case. Fig. 42.
3. Remove the crankshaft bearing housing seal face plate from the bearing housing. This is part of the seal replacement package, and must be replaced when the seal assembly is replaced.
4. Remove the seal from the crankshaft.

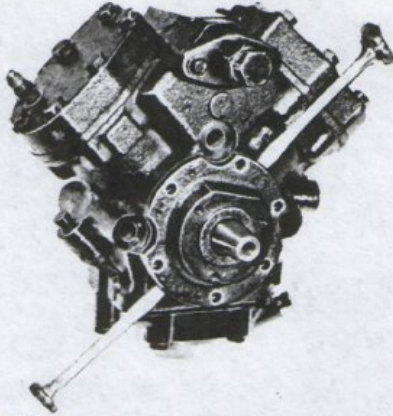

Fig. 42. Crankshaft Bearing Housing Removal

Installation:

The crankshaft seal replacement package consists of the crankshaft seal assembly and the crankshaft bearing housing seal face plate. Two types of crankshaft seals are supplied for service, as shown in Fig. 43. If the replacement package contains the cartridge-type seal, follow the entire installation procedure given below. If the replacement package contains the unitized-type seal, steps 1, 2 and 4 will not apply.

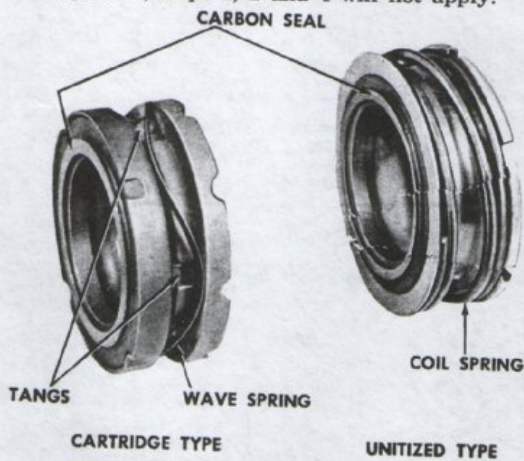

Fig. 43. Compressor Seal Identification

1. Before installing cartridge-type seal assembly, check assembly to make sure that tangs index in slots of mating part. This will insure proper spring action. The carbon seal must be assembled, as shown in Fig. 43.
2. Hold the seal firmly on the outside edge to prevent it from rotating out of the index slots.
3. Lubricate the crankshaft with refrigerant oil. Slide the seal on the crankshaft with the smooth (carbon seal) surface up, or toward front of the compressor.
4. When the seal bottoms against the crankshaft bearing, check indexing of tangs again by pressing down with thumbs to see if it has the proper spring action.

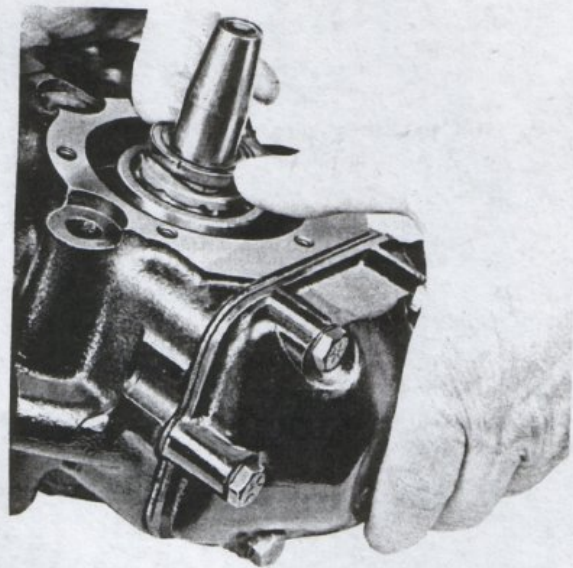

Fig. 44. Checking Indexing of Tangs

5. Lubricate and install the crankshaft bearing housing seal face plate with the smooth (micro-finish) side up. Use a sleeve with the minimum inside diameter of 1-3/8 inches to avoid damaging the micro-finish sealing surface of the face plate. Tap sleeve lightly until the seal face plate is fully seated in housing.
6. Install bearing housing oil seal, using plenty of refrigerant oil.
7. Install housing, making sure that it is in proper alignment with screw holes. The seal assembly may be damaged if the bearing housing is rotated after the housing seal contacts the carbon seal.
8. Install bolts and tighten 10 to 13 foot-pounds.

Table 7. Chrysler Compressor Torque Requirements

	Foot-Pounds	Inch Pounds
Compressor Bearing Housing Bolt	10-13	—
Compressor to Bracket Bolt	50	—
Compressor Connecting Rod Screw	—	52-56
Compressor Cylinder Head Cover Bolt ..	23-27	—
Compressor Cylinder Head Cover Nameplate Bolt	20-24	—
Compressor Discharge Adapter Bolt	14-18	—
Compressor to Engine Bolt	30	—
Compressor Oil Pump Cover Bolt	10-13	—
Compressor Oil Sump	15-19	—
Compressor to Strut Bolt	30	—
Compressor Suction Adapter Bolt	10-14	—
Magnetic Clutch to Compressor Bolt	20	—

e. Valve Plate:

1. Remove the cylinder head bolts and the head and valve plate assembly. If the plate does not separate from the head, tap the removing lip on the

valve plate lightly with a plastic hammer. Do not pry apart.

Inspection:

After removal of head, plate and gaskets, examine valves. If valves are broken and damage extends to cylinder bores, examine bores to see if they can be repaired by removing light scoring, scuffing or scratches with crocus cloth. After conditioning cylinder bores, clean the surfaces of the cylinder block, valve plate and head thoroughly with mineral spirits. Use care to remove all shreds of old gasket from plate, block and head surfaces. Clean attaching stud holes in block. If valve plate or cylinder head is damaged, replace, using a complete compressor valve plate replacement package.

1. The valve plate and cylinder head must be assembled with the reed valve assembly positioned, as shown in Fig. 45.
2. Dip gaskets in clean refrigerant oil. Using pilot studs as a guide, install valve plate gasket, valve plate, cylinder head gasket and cylinder head, as shown in Fig. 46.
3. Install attaching bolts. Tighten each bolt alternately and evenly 23-27 foot-pounds.

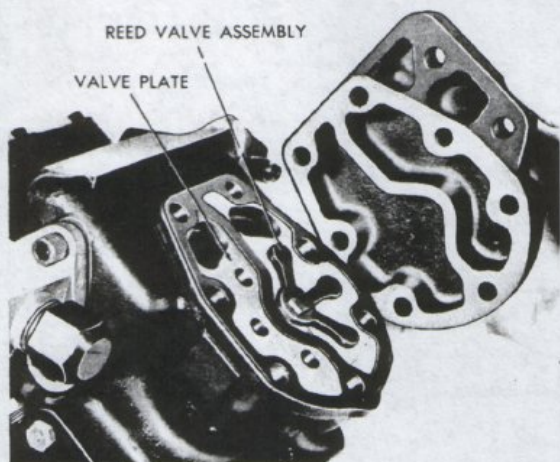

Fig. 45. Valve Plate — Installed Position

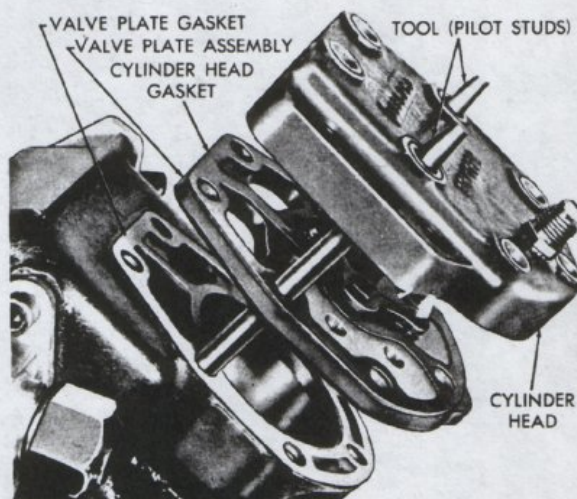

Fig. 46. Installing Valve Plate and Cylinder Head

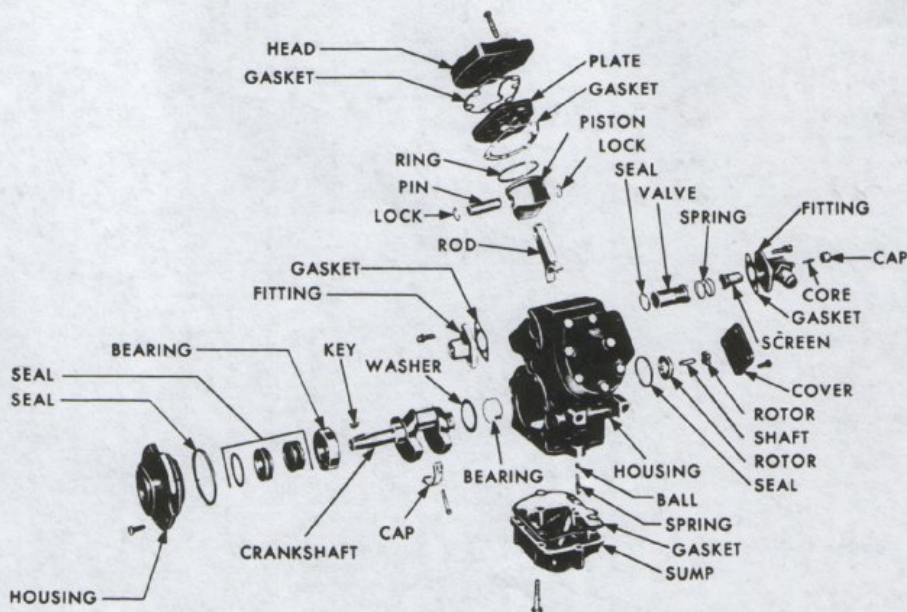

Fig. 47. Chrysler Compressor — Exploded View

CLUTCHES

1. GENERAL:

Automotive air conditioning systems use electromagnetic clutches to drive the compressor. The clutch pulley free wheels when the air conditioner is not being used, so the compressor is not being operated needlessly. This feature eliminates the necessity of removing the belts during the winter months. Having a clutch also eliminates using a compressor by pass or unloading solenoid valve.

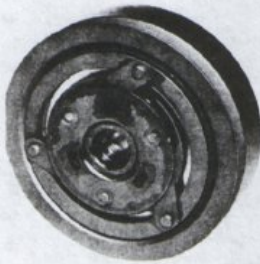

Fig. 48. Typical Clutch Assembly

Clutches used on automotive air conditioning systems are of two general types. These are called the rotating coil type and stationary coil type. Both types of clutches are in use today.

The stationary coil type has the magnetic coil bolted to the compressor crankcase. The rotating coil type has the coil installed inside the rotating pulley, and the electrical current is carried to the coil by a brush assembly bolted to the compressor crankcase. The brushes make electrical contact to a slip ring on the pulley.



Fig. 49. Clutch Brush Assembly

All electrical clutches operate on the same principle. They have a coil wound within a metal cup core, which acts as a horseshoe magnet when the coil is electrically energized. See Fig. 50.

The pulley rotates on a bearing mounted on the clutch hub. The clutch hub is keyed to the compressor shaft. There is a disc attached to the hub with several springs. The springs hold the disc away from the pulley when the clutch is not energized, leaving the pulley free to rotate on the hub. When the field coil is energized, a magnetic field is created. The lines of magnetic force bridge the air gap between the field coil cup and rotating pulley as indicated by arrows. The continuing arrows show the magnetic path which, because of air barriers, crosses back and forth between the pulley and disc. These cross-over lines of force strongly attract the disc against the pulley, creating a frictional driving force. This brings the disc and the hub through the springs into rotation with the pulley to drive the compressor.

When the coil is de-energized, there is no longer a magnetic field. The springs pull the disc away from the pulley, allowing the compressor to stop while the pulley continues to rotate.

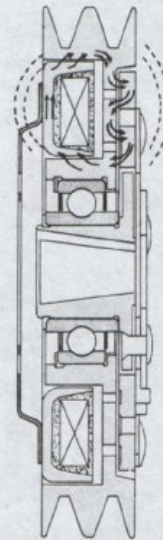

Fig. 50. Magnetic Clutch Operation

The electrical power to the coil is controlled by three switches. They are the automobile ignition switch, the air conditioning unit on-off switch, and the thermostatic switch. All three of these switches must be on to electrically energize the clutch. The air conditioning

system will be in operation any time the clutch is engaged, driving the compressor.

When a clutch is suspected of coil failure, before replacing the clutch, connect a jumper wire directly to the clutch from the battery. If the clutch engages, the problem is not in the clutch but in the wiring to the clutch.

There are so many individual variations of clutches used on automotive air conditioners that it is not practical to cover each in detail.

2. CLUTCH REMOVAL:

Never use a hammer to remove a clutch from a compressor shaft, or damage to the clutch and compressor will usually result.

The first step to remove the compressor clutch from a York, Tecumseh or Chrysler compressor is to loosen and remove the drive belt from the pulley. After the belt is removed, the cap screw or bolt and washer which secures the clutch to the compressor shaft may be removed. Most clutches are removed by threading a 5/8" NC (course thread) cap screw into the clutch hub. When the cap screw is screwed against the compressor shaft, the clutch assembly will be forced free. After disconnecting the electrical wire, the clutch coil (or brush assembly), depending on the clutch manufacturer, may now be removed from the compressor.



Fig. 51. Typical Outboard Mounted Clutch Field Coil

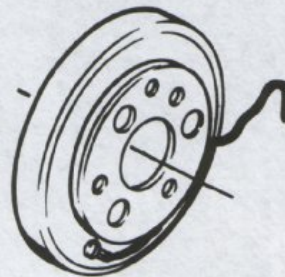
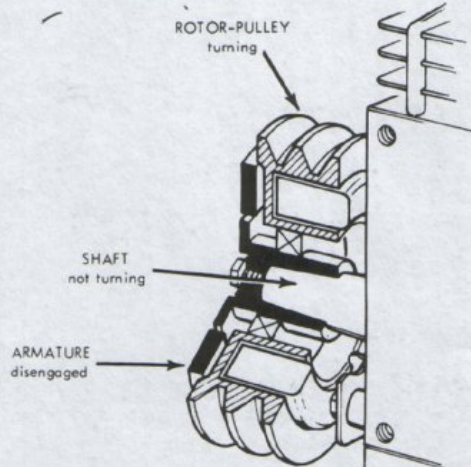

Fig. 52. Typical Inboard Mounted Clutch Field Coil

Slide the pulley assembly onto the shaft, making sure the hub keyway is aligned with the key in the shaft. Secure the assembly to the shaft using the cap-screw and washer supplied with the new clutch. Turn the assembly by hand to be sure there is no binding due to improper seating of the hub on the shaft.

WARNING: Do not use a hammer to install the clutch, as there is danger of damage to the clutch and

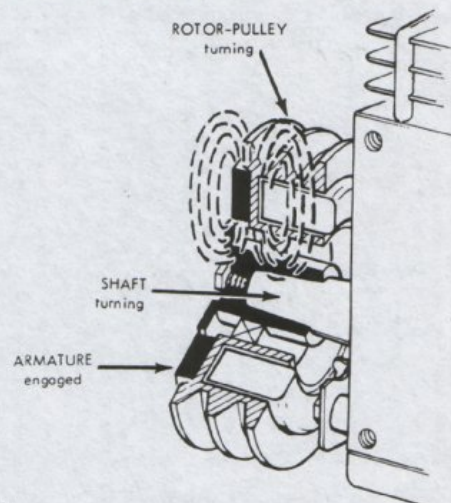

Fig. 53. Clutch Operation

compressor. Warranty will be void by all companies if there is evidence of prying or hammering on the clutch or compressor.

The installation of the General Motors compressor, like its removal, requires special tools found in kit part number 07-90118. See Chapters 5 and 15.

4. TROUBLE-SHOOTING:

If the clutch does not engage, check the system as follows: Check the electrical system for broken wires or loose connections. Carefully check the lead wire from the clutch for wear against some moving, sharp or hot part in the engine compartment. Check the fuse or circuit breaker, the automobile accessory switch, the fan control switch, and the thermostatic switch to be sure they are closed to complete the circuit to the clutch.

Check the condition of the brushes used with Eaton clutches. If these brushes are dirty and worn, there is

a chance that they are not making good electrical contact. These brushes must be kept clean and free in the brush holder to make proper contact.

If the clutch is slipping, check to be sure the clutch is clean and free from grease and oil. Be sure the compressor turns freely by hand. Also, be sure there are no loose electrical connections.

Several things will cause a noisy clutch. Check to make sure the pulley turns freely without binding with the clutch not engaged. Check the belts for tightness, as a slipping belt can cause noise.

The pulley bearing may be worn out and making noise. Replacing the bearing is not recommended. A complete new rotor assembly should be installed.

It is normal for a new clutch to emit a short squeal when initially engaged. This noise should disappear after the clutch is engaged a few times, allowing the mating surfaces to wear in.

RECEIVER TANKS AND DRIERS

1. RECEIVER TANKS:

The receiver tank is usually a welded cylinder installed in the liquid line after the condenser. Its purpose is to provide an extra reservoir of refrigerant to be used during periods of high demand. This surplus refrigerant, which is stored in the receiver tank, will also compensate for slight leaks that may be in the system and thereby prolong the time before recharging of refrigerant is required.

The total quantity of Refrigerant-12 in a fully charged system is approximately 2½ pounds. When the charge falls too far below this quantity, the efficiency of the air conditioner will drop; if the system has too much refrigerant it will result in too high a head pressure and a lower efficiency. A receiver will compensate for slight errors in the amount of refrigerant charge—however, the more accurately a system is originally charged the more efficient a system will be.



Fig. 54. Receiver-Drier with Push-On Fittings

A receiver is constructed with a dip tube extending to near the bottom of the tank on the outlet connection. This feature permits liquid refrigerant from the bottom of the receiver tank to be picked up and carried to the expansion valve. As long as the refrigerant liquid level in the receiver tank extends above the bottom of the dip tube, no refrigerant gas will enter the liquid line. If the refrigerant charge falls too low in the system, this liquid seal is broken and gas enters the liquid line and bubbles will appear in the sight glass. Bubbles in a sight glass are an indication of refrigerant shortage in the system.

Because of the dip tube feature at the receiver outlet, it is essential that the receiver tank be installed with the inlet towards the condenser and the outlet towards the expansion valve.

Receiver tanks may be either horizontal or vertical construction, and must be installed according to manufacturers' recommendations. A full understanding of the principles of receiver tanks construction will enable

the serviceman to inspect the tank and install it properly in respect to direction of refrigerant flow and mounting position.

Some receiver tanks are furnished with a shut-off valve on the outlet side. This feature allows the serviceman to "pump down" the system and save the refrigerant when it is necessary to open the system and perform service. (See System Pump Down, Chapter 9.)



Fig. 55. Receiver-Drier with Flare Fittings

A receiver tank is not serviceable. If a leak should develop or the tank or valve becomes damaged, it must be replaced as an assembly. Receiver tanks which incorporate an integral drier are no longer serviceable if the system is opened to the atmosphere (see driers below).

2. DRIERS:

The purpose of a drier in a refrigeration system is to absorb moisture. A drier may be a welded or formed metal cylinder; it may be designed and built as an integral part of the receiver tank; and it may or may not have a sight glass as a part of the assembly.

Moisture is one of the worst enemies of a refrigeration system, and can cause the expansion valve to malfunction and premature compressor failure. Moisture is usually introduced into a refrigeration system through improper installation and service procedures. There is always moisture in the air that surrounds us, in and on the walls of tubing and hoses used in the installation; and possibly in the refrigerant and oils used to service the air conditioner.

If all the moisture remaining in a refrigeration system totals even as much as one drop, it can collect and freeze on the expansion valve seat and cause restriction of refrigerant flow and loss of air conditioning.

Moisture also forms acids within the system and attacks the compressor parts, and over a prolonged period of time will cause compressor failure.

Driers are installed in the liquid line and all of the refrigerant passes through the desiccant contained in the drier. This desiccant has the property of absorbing the moisture from the refrigerant as it passes through the drier. Each drier has the ability to absorb just so much moisture depending upon the quantity and type of desiccant and the location of the drier in the system.

It is possible that the drier can become expanded or used up if too much moisture is contained in a refrigeration system, and it will have to be replaced.

As a general rule, a drier should be replaced each time the refrigeration system is opened and exposed to the atmosphere. Care must be taken when installing a drier that is new and the end seals are intact. The desiccant in a drier will absorb moisture from the air as well as from refrigerant, and could become expanded before installation if careless methods are employed.



Fig. 56. Typical Ford Factory Installed Receiver-Drier

3. COMBINATION RECEIVER-DRIERS:

Automobile air conditioning systems usually use a receiver-drier that is assembled as one unit. Each portion of the assembly still performs its own function as described above.

The same care must be taken when installing this assembly that would be taken with a drier.

4. SIGHT GLASS

A sight glass may be found on the receiver outlet or drier outlet. It may also be found as a separate unit in the liquid line or as an integral part of the expansion valve. It is actually a window that allows the serviceman to observe the flow of liquid refrigerant within the system.

The sight glass should be clear with liquid refrigerant and reveal no bubbles. Bubbles in the flow of refrigerant indicates an undercharge or shortage of refrigerant. The sight glass is used as one of the first references when diagnosing troubles on an auto air conditioner.

A sight glass will tell you if the system is short of refrigerant, but will not tell you if you have too much refrigerant.

5. REMOVAL:

- a. Discharge the refrigerant from the system.
- b. Using the proper combination of wrenches, remove the component from the unit. Do not twist or kink the connecting tubing.
- c. Cap both inlet and outlet lines to prevent the entrance of moisture into the system.

6. INSTALLATION:

- a. Remove the protecting caps and plugs from component and connecting lines.
- b. Tighten flare nuts finger tight.
- c. Using the proper combination of wrenches, tighten flare nuts. Do not twist or kink the connecting tubing.



Fig. 57. Typical GM Factory Installed Receiver-Drier

7. TROUBLE-SHOOTING:

Receiver tanks and driers are not ordinarily the causes of failure in an auto air conditioning system. Although it is possible to experience a cracked or damaged component, in which case the component should be replaced.

Driers and receiver-driers become clogged with foreign matter, or the drying agent become expended through use. Both of these examples only show the component is doing the job it was designed for, and should be replaced.

Any time a drier or receiver becomes plugged with foreign material, it will cause a reduced flow or complete stoppage of refrigerant circulation. This will be evidenced by a low suction pressure, improper cooling, and lack of refrigerant flow at the sight glass.

If a drier or receiver-drier becomes expended through use, and moisture is still present in the system, this moisture might freeze out at the expansion valve seat and cause a stoppage of refrigerant circulation. This condition is evidenced by a low suction pressure and improper cooling.

Moisture can be present in the system and still not freeze out at the expansion valve orifice. This moisture will eventually combine with the refrigerant and form acids that attack the refrigerant oil and internal metal parts of the system. For this reason, it is important to replace the drier each time the system is opened and to follow recommended installation, charging, and evacuation procedures.

VALVES

1. SERVICE VALVES:

The discharge and suction service valves are three-position valves and are mounted on each side of the compressor.

The suction side of the compressor is identified by the letter "S" or word "Suction" cast in the cylinder head. The discharge side is identified by the letter "D" or word "Discharge."

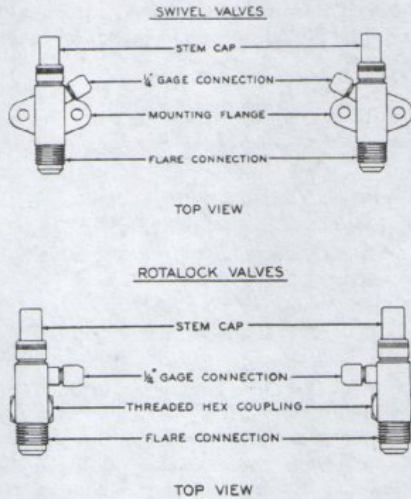

Fig. 58. Swivel and Rotalock Service Valves

The purpose of a three position valve is to allow a gauge connection to be made and used while the system is in operation. This can be used for service checks, bleeding, evacuating and charging. Also, the compressor may be removed from its bracket to enable engine work to be performed on the car by closing the service valves and removing them intact with the lines attached, from the compressor.

When the stem is turned in, the valve is "front seated." When the stem is turned out, the valve is "back seated." When the stem is turned to the half-way position, the valve is commonly known as being "cracked."



Fig. 59. Schrader Type Valve Core Remover and Replacer

The "front seated" position allows the compressor to be removed from the system and serviced. The "back seated" position is the normal valve position when the refrigeration system is in service. The "cracked" position allows the refrigeration system to operate normally, and gauge readings to be observed at the same time.

Packing gland nuts should be kept snug to prevent loss of refrigerant. Care should be taken that valve caps and gauge port caps are intact when service work is ended.

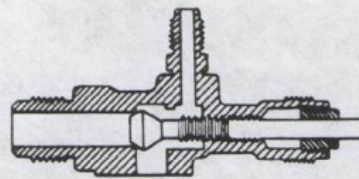

Front Seated position

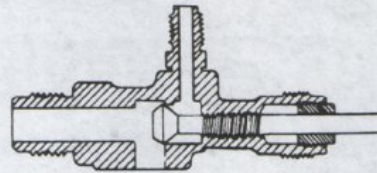

Back Seated position

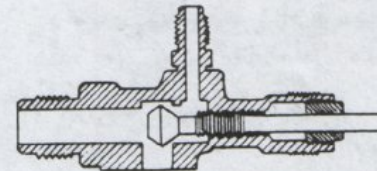

"Cracked" position

SERVICE VALVE POSITIONS

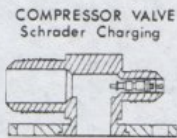

Fig. 60. Service Valve Positions

Compressors may also be equipped with Schrader type valves in place of the three-position valves. These Schrader valves work on the same principle as a tire valve, and your charging line must be equipped with a valve core depressor in order to obtain gauge readings or service the system, or a special Schrader type tool used. On units which are equipped with Schrader valves, the refrigerant charge must be released when the system is to be opened for service.



Fig. 61. Installation and Use of 07-90119 Schrader Type Valve Tool

2. SUCTION THROTTLING VALVES (STV):

1. General:

The suction throttling valve determines the temperature of the evaporator coil by limiting the minimum evaporator pressure. In this manner, the valve also protects the coil against freeze-up which would result in a partial or complete loss of cooling capacity. While the system is in operation, the evaporator will be held to a minimum pressure of 28 psi, and will provide maximum cooling at all times. The evaporator pressure will hold at this level so long as maximum cooling is desired. Should the cold air output begin to become uncomfortable, the Temp lever may be moved to mix heated air with the maximum cooled air, and thus temper the outlet air to a desired temperature. This

action, indicating that maximum cooling is no longer needed, acts through the Temp control cable and linkage to close a vacuum valve through which $4\frac{1}{2}$ " of vacuum has been applied to the vacuum head on the STV. Loss of this vacuum increases the internal spring pressure exerted upon the STV piston and effectively increases the minimum evaporator pressure approximately three pounds to 31 psi. This results in less evaporator cooling capacity. The primary reason for this feature is to guard against evaporator freeze-up when operating at higher elevations.

2. Removal:

- a. Purge the system of refrigerant.
- b. Remove right front fender skirt of automobile.
- c. Remove the STV and cap or plug all connections.

3. Installation:

- a. Install the suction throttling inlet to the evaporator outlet connector. Make sure a new "O" ring is used.
- b. Install the STV on mounting bracket.
- c. Using new "O" rings, install the STV outlet line, expansion valve equalizer line, and oil bleed line to the valve.
- d. Install the vacuum line on the STV.
- e. Install new drier and evacuate and charge the system.
- f. With the low pressure gauge line installed on the STV gauge fitting, adjust the valve (by turning the vacuum head as required) until, with the system in operation, the evaporator holds at 28 psi.
- g. Pull the vacuum line off the vacuum can. The evaporator pressure should rise about 3 psi. Replace the vacuum hose.
- h. Replace the fender.

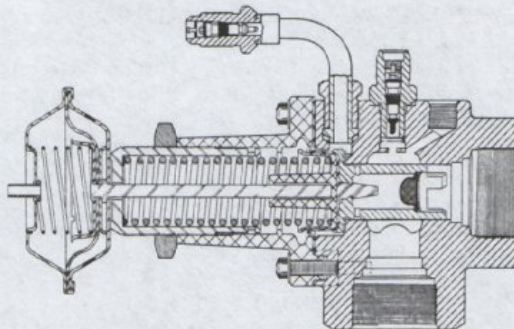

Fig. 62. Suction Throttling Valve — Sectional View

4. Trouble Shooting:

To check for proper operation of the STV, proceed as follows:

- a. Attach the suction pressure gauge to the suction throttling valve gauge connection.

- b. With the air conditioning system in operation, check the gauge readings. The gauge should read about 28 psi; depress the Temp lever about $\frac{1}{2}$ "; the gauge reading should rise about 3 psi to 31 psi.
- c. If no change in gauge reading occurs, or if an initial reading of 28 psi cannot be obtained, check the following items:
 1. Check vacuum head assembly for damage.
 2. The vacuum hose may be pinched off, broken or unplugged from vacuum head assembly.
 3. Linkage may be out of adjustment.
- d. If no visible evidence of malfunction can be found, the following checks become necessary:
 1. A vacuum reading on the low pressure service gauge is an indication that the STV diaphragm is defective, and the refrigerant has leaked out through the vacuum manifold. Check the sight glass for shortage of refrigerant. Add refrigerant, and leak test the vacuum connection of the STV.
 2. Failure to cool, poor cooling, and partial frosting and sweating of the evaporator coil are indications that the STV is malfunctioning and defective. Repair or replace if necessary.

3. EVAPORATOR PRESSURE REGULATORS (EPR):

1. General:

Evaporator pressure regulating valves are used to limit the minimum evaporator pressure. This, in turn, protects the evaporator coil from freezing under certain operating conditions.

The valve is preset to the manufacturers' own specifications for a specific application, but usually has an external means of adjustment for field needs.

Construction features of these valves will vary, but its operation and function is similar to the STV. The STV is adjustable and may be regulated through linkages by the operator. The EPR valve is usually set, and any adjustment would be by a serviceman.

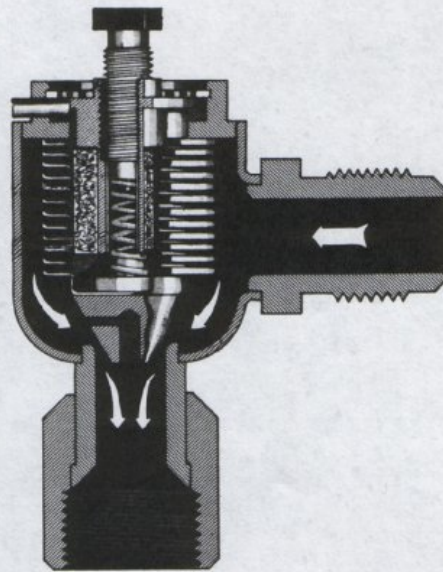

Fig. 63. Typical EPR Valve

The valve is installed between the evaporator and the compressor in the suction line. No external means of attaching manifold gauges is usually provided. For this reason, it is not possible for the serviceman to observe the evaporator suction pressures, but only suction pressures at the compressor suction service valve inlet port. This lack of operating pressure and temperature information often hampers the serviceman in making proper diagnosis. It is often difficult to pinpoint the problem between the thermostatic expansion valve and EPR valve. Trial and error is the most used method—replacing one part and if that does not work, replace the other until the unit works satisfactorily again.

Removal, installation and trouble shooting procedures are essentially the same as for the STV, with the additional problem of being unable to observe all operating pressures.

ELECTRICAL EQUIPMENT

1. GENERAL:

There are four basic functional parts of the automotive electrical system. They are the fan or blower, switch or control, the thermostatic switch, the fan or blower motor, and the clutch field.

There are also the wires connecting these components together, and the fuse or circuit breaker which protects the system.

2. MOTORS:

Automotive air conditioners use two basic motors. They are the single speed and multiple speed motors. These motors are used to circulate the air within the automobile across the evaporator coil where the heat is removed from the air.

The motors drive fan blades or blower wheels. Most of the modern air conditioners utilize the blower rather than the fans. Generally, there are two configurations of blowers. There is the single shaft blower, which utilizes a single blower wheel. The other is the double shaft motor driving a blower wheel at each end of the motor.

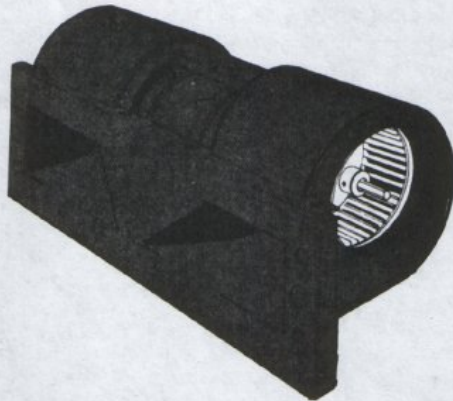

Fig. 64. Blower Assembly

Almost all automotive air conditioners have a method of air volume control. The speed of the motor controls the volume of air passing across the coil. A rheostat or resistor switch is used with the single speed motor to control its speed. The rheostat is a continuously variable resistor connected in series with the motor. The resistor controls the current flow to the motor, which controls the motor speed. Most of these rheostats have an off position where no contact is made with the resistor.

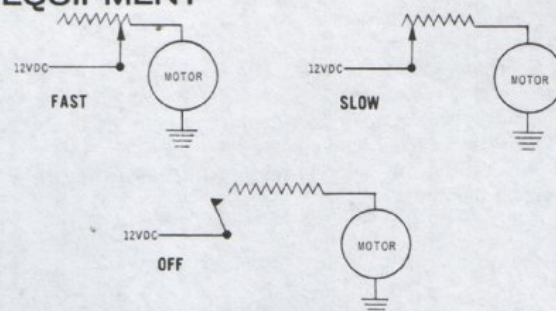

Fig. 65. Rheostat Switch Motor Speed Control Electrical Circuits

The resistor switch works the same way as the rheostat, except the speed is not continuously variable. Most resistor switches give a choice of three speeds using two resistors.

Another method of speed control used is the multiple speed motor. These motors have special internal windings for each speed required. Wire leads for each of the speeds is connected to a speed selector switch to enable the operator to connect battery voltage to the particular winding for the speed desired.

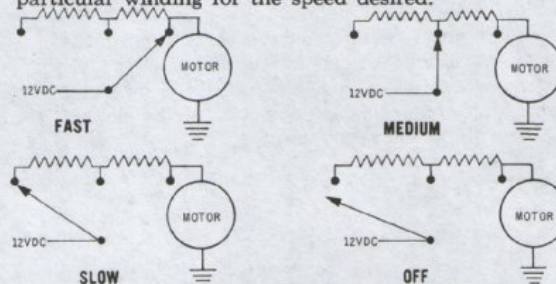

Fig. 66. Resistor Switch Motor Speed Control Electrical Circuits

When changing motors, attention must be paid not only to the type of replacement motor needed, single or multiple speed, but also to the voltage required. Six or 12 volt motors are available. Six volt motors must be used on 6 volt automobiles, and 12 volt motors on 12 volt systems.

It is not economical to repair defective or worn out automotive air conditioning motors. They should be replaced with a new motor.

Some special installations such as Taxicabs, Chevrolet Corvairs and Volkswagens use electric motors to drive fans to circulate cooling air through the condenser. These fans are driven by single speed motors. Most of these fans are controlled by a pressure switch connected to the condenser. The fan will run when needed, depending upon head pressure. It will be noted on these systems that the head pressure will be excessive when the vehicle is at rest if the fan motor or pressure switch is defective.

a. Motor Maintenance:

No periodic maintenance is required on the fans or blowers. Customer complaints usually fall into two categories. No air, which indicates the motor is defective and must be changed, or no electrical power is getting to the motor, which requires the repair of wiring or changing of controls. The other complaint is noise. Fan or blower noises come from several sources. The motor brushes can cause noise. About the only way this can be fixed is to change the motor. The motor bearings can be the cause of noise, which again means changing the motor.



Fig. 67. Circuit Breaker

Noise can also be caused by bent and unbalanced fan blades or blower wheels. This noise can be stopped by changing the blade or wheel.

Misalignment of the blade or wheel on the shaft can cause noise due to striking the scroll or housing. Misalignment or deterioration of the motor shock mounts can cause noises. With a blower, it is important to have the blower wheel centered in the scroll air inlets. In some cases, alignment can be accomplished by repositioning wheels on the shafts or the motor in the mount. Motor mount holes can sometimes be elongated to help an alignment problem.

3. SWITCHES:

a. General:

Switches are used in the electrical circuits to control the various operating components. Several types of switches are used in automotive air conditioners. These types are common switches that are usually either rotary or push button. There is the bi-metallic and the fluid charged pressure type thermostatic switch. Some of these thermostatic switches incorporate a manual off position. Some special automotive air conditioners also have a pressure switch to control the condenser fan when it is driven by an electric motor.

b. Common Rotary or Push-Button Switch:

This switch is used to turn the unit on and off, and also to control the evaporator fan motor speed. Two types of failures are common with this switch — they can short or open circuit. If the switch shorts, the unit will not stop running when the switch is moved to the off position. This is caused by a short between contacts. A switch short can also cause blowing of the fuse or tripping of the circuit breaker. This is caused by a short from one of the contacts to ground.



Fig. 68. Switch with Resistor

An open circuit of the switch will cause the clutch or fan to be inoperative when in that position. The switch is not repairable, and must be replaced if it fails.

Some of the switches will include built in resistors to control fan speed. If a resistor fails, the switch must be replaced.

c. Pressure Switches:

Pressure switches are used on special units where an electric fan is used to force air through the condenser coils. These fans are automatically turned on and off with the pressure switch. The pressure switch pressure line is connected to the high side of the system, and operates on and off depending upon the high side pressure. This switch will have the short circuit and open circuit failures common to the other switches in this section.

It will be noted that the pressure switch used in the system is adjustable. It is possible that the only problem with the switch is that it is out of calibration. If this is true, the switch may be adjusted if the system operating pressure is known.

4. RHEOSTATS:

Some units will have a separate rheostat to control the evaporator fan motor speed. The rheostat is a variable resistor used to control fan motor speed. The rheostat is subject to two types of failures; an open or short circuit.

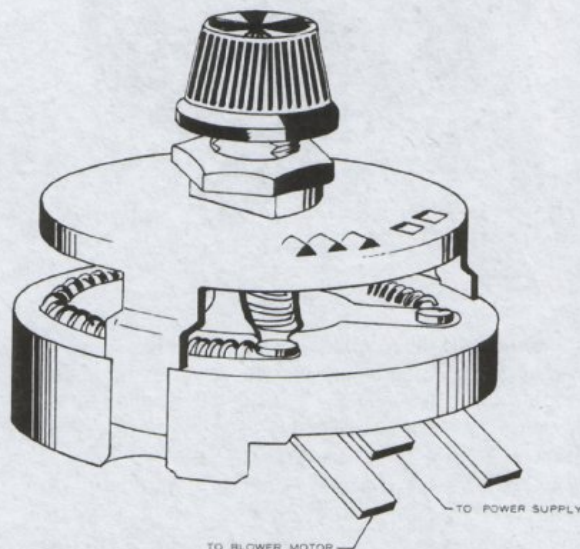

Fig. 69. Rheostat

A short circuit will cause the fan motor to run at one speed at all rheostat positions, or cause the fuse or circuit breaker to open the circuit.

An open circuit will cause the motor to stop running at certain positions of the rheostat knob. The rheostat is not repairable and must be replaced if it fails.

5. THERMOSTATS:

Thermostats are used to control the electric clutch on the compressor. Two types of thermostats are found in automotive air conditioners. They are the bi-metallic and fluid charged thermostat. The thermostat makes and breaks the clutch circuit depending upon the temperature of the evaporator coil or air leaving the coil.

The sensing element of the bi-metallic thermostat is made up of dissimilar metals banded together, which have different coefficients of expansion. Any change in temperature of the element initiates a bending or straightening motion, depending on the direction of the temperature change caused by the difference of stresses in the two metals. This movement is used to open and close the contacts at the desired temperature setting.

The bi-metallic element is located in the air stream and senses changes in the air leaving the coil. The fluid charged thermostat has a small diameter tubing for the sensing element. The sensing element is inserted into the coil fins to sense coil temperature. This tube is closed at one end and the other end is connected to a small closed bellows. The tube and bellows are charged with a fluid very similar to Refrigerant 12. Changes in temperature effect the charge pressure. When the charge pressure changes the bellows will change in length. This change in length of the bellows is used to actuate the contacts which control power to the compressor electric clutch.

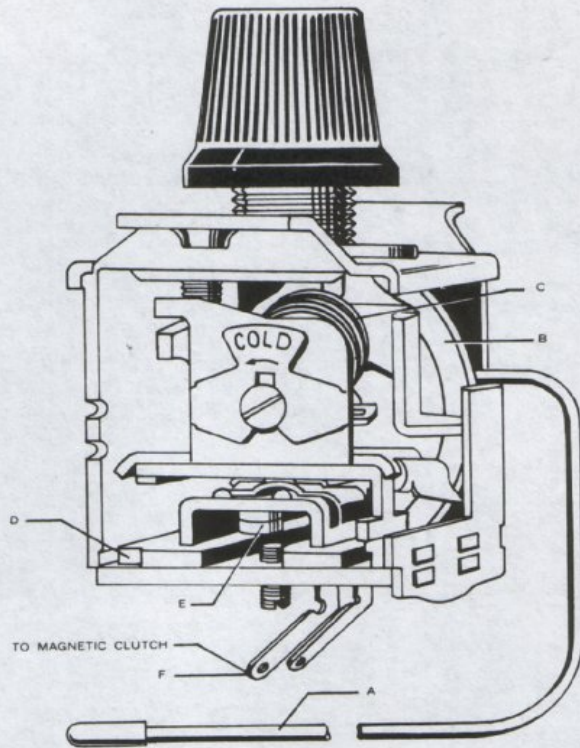

Fig. 70. Thermostat

This thermostat is subject to shorts and open circuits like the other switches in this section. The charge can be lost if a leak occurs in the bellows or capillary tube. Once the charge is lost, the thermostat must be replaced because it cannot be recharged.

Both the bi-metallic and fluid charged thermostats can go out of calibration. It is easier to replace the thermostat than try to recalibrate it. Most manufacturers do not publish calibration temperatures for their thermostats.

Chapter 10

HOSES, MOUNTS, PULLEYS AND BELTS

1. HOSES:

For ease of installation, automotive air conditioning systems use hoses for all refrigerant lines. These hoses are especially designed for refrigerant use and if installed correctly, should last the life of the unit.

Some hoses have crimped non-replaceable fittings, others have replaceable screw ends and still others are of the push-on fitting and clamp type. In each case, follow the manufacturer's specific installation instructions.

Most hose failures are due to improper installation, and extreme care should be taken when installing replacements. Use only a hose that is designed for refrigerant use.

Hose installations should have as large a radius bends as possible to avoid kinks or pinches or restriction of refrigerant flow.

Make sure that the hose is routed to clear hot engine manifold, sharp metal edges, battery, and radiator fan blade.

Use plenty of hose clamps so hose won't vibrate and to avoid abrasive action. Do not install hose clamps too close to compressor so as to restrict movement of the compressor with the engine.

Refrigerant oil should be used on all hose fittings and connections, and grommets should be installed to protect hose routing through the firewall or other partitions.

Caps and plugs should not be removed from hose ends until hoses are ready for installation. Two or more wrenches should always be used to prevent twisting or distorting the hose.

2. MOUNTS:

It is important that the compressor mount assembly be installed exactly according to the manufacturer's recommendations. Do not omit any studs, washers, bolts or braces, as all are necessary for proper alignment and strength.

Mounting bolts or studs should all be started and then tightened evenly. Unless this procedure is followed, you might warp the mount and you will be unable to obtain proper alignment.

On aluminum engine blocks "anti-seize" compound must be used on all studs or bolts.

3. PULLEYS:

When installing drive or idler pulleys, care should be taken that seating surfaces are free of all dirt and grit before installation.

Check keyway and key for fit and alignment. Make sure pulleys and drives line up perfectly by placing a good metal straight edge flat against the machined forward edges of drive pulley.

All pulleys and drives must run true and be free of wobble.

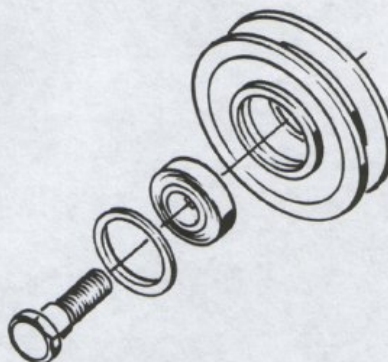

Fig. 71. Idler Pulley

4. BELTS:

Proper belt tension, alignment and installation are essential for long belt life, quiet operation and top system performance.

Belts should never be forced on drives with a screw-driver or similar tool, as you are likely to fracture the cords and decrease belt life.

If belts are over tightened, premature failure of clutch and compressor bearing will occur.

A belt of proper tension will depress about $\frac{1}{2}$ " in the middle of its longest span. Another good tension guide is to twist belt at midpoint of longest span, and you should be able to turn the belt $\frac{1}{4}$ " to $\frac{1}{2}$ " with some effort.

A belt should not slip when engine is idling, and the head pressure is approximately 250 psi. If a belt tension gauge is used, a new belt should be tensioned to 100-125 lbs., and a used belt to 80-100 lbs.

After 24 to 36 hours of operation, a new belt will stretch and another tension check should be made. Do not over-tension newly installed belts to compensate for this initial stretch.

AUTOMOBILE COOLING SYSTEMS

The addition of an air conditioning cooling system to an automobile imposes an extra load on the engine and cooling system. For good performance of the air conditioning system, the engine and cooling system must be in good condition and operate properly.

Many times an untuned engine or a rusty cooling system will cause malfunction of the air conditioning system. Often improper air conditioning is the first indication of any problem to the automobile owner, and he will naturally bring his automobile to an auto air conditioning service shop.

The auto air conditioning serviceman must thoroughly understand the automotive cooling system to be able to make a proper diagnosis.

When the air conditioner clutch is engaged, an additional work load is imposed on the engine. The engine will run hotter and the cooling system will work harder. Under normal conditions this is no problem, but if any part of the cooling system is not up to par the engine will overheat and may cause trouble.

The same factors affect the capacity of an automobile radiator as an air conditioner condenser. Namely, physical size, temperature of coolant inside and air outside, an amount of air passing through the radiator.

Since the engine cooling system is already loaded to capacity, care must be taken that it be in top condition. If bugs, dirt, leaves or other debris are allowed to collect on the face of the radiator, they will restrict the flow of air over both the radiator and condenser. Any restriction of air flow will result in a higher engine temperature and a higher condensing temperature. Both of these factors work against each other because when a higher condensing temperature is present, it is the very time that more engine capacity is required to overcome this higher pressure in the refrigeration system. Yet, this is the time when the engine is already in a loaded condition. It is vitally important that air flow over both the radiator and condenser is never restricted.

Restricted air flow can be caused in other ways. Radiator or condenser fins can be bent during installation, or by accident when performing service work. These fins should always be inspected and straightened with the proper size fin comb if necessary. If grease or oil is spilled on the tubes and fins, they will collect dirt, and not only will air flow be restricted but the heat transfer efficiency of the tubes and fins will be greatly reduced. Often steam cleaning is the only answer if too much oil, grease and dirt has collected on these surfaces.

Automobile air conditioner manufacturers recognize

that improper air flow will cause malfunction of the system, and in some cases will furnish a larger fan blade in the installation kit to overcome this problem. Of course, there is no way to determine if this larger blade was omitted from the original installation, but care should be taken to use such a fan blade on a new installation if furnished in the kit. Larger fan blades and fans with more blades are available on the replacement market if you feel they are necessary.

On older installations it is possible that the coolant is dirty, or that the radiator or engine block require flushing and cleaning. The engine coolant thermostat should also be checked for performance. A pressure cap tester should be used to see if the radiator pressure cap holds the automobile manufacturer's recommended pressure.

If the engine requires a tune up, it will always run hotter than normal. This condition can reflect back to inadequate performance of the air conditioning system.

Unless the car engine and cooling system are in good condition, the serviceman cannot always satisfy customer complaints. However, he should be aware of the problems and be prepared to explain to the customer where the real problem is.

During recent years some automobile manufacturers have offered optional sizes of factory installed radiators. A smaller radiator being installed on cars not factory equipped with air conditioners, and a larger size radiator for cars that are ordered with factory equipped air conditioning systems. This poses a problem for the serviceman who installs and services independent automobile air conditioning systems.

Unless an automobile is ordered with the larger radiator as a factory option, it becomes quite expensive to order and install the larger radiator at a later date. There is no real answer to this problem, however, the serviceman should be aware of the problem and be prepared to explain to his customer what is involved. Often, an explanation and a word of caution on the use of his air conditioning system will suffice. The customer should be prepared to avoid running his air conditioning system at idle speed for long periods of time, and should take every precaution that his car be tuned and the cooling system well taken care of. For the small difference in original cost, a new automobile should always be ordered with the larger optional radiator even if factory installed air conditioning is not ordered.

It should be clear that both the serviceman and the car owner should take proper care of the automobile and cooling system in order to obtain optimum performance from the air conditioning system.

INSTALLATION OF THE UNIT IN THE AUTOMOBILE

1. GENERAL:

A complete automobile air conditioning installation kit usually contains four basic component kits.

- a. Evaporator Assembly Kit—contains the evaporator assembly, mounting brackets, drain hose and necessary hardware.
- b. Condenser Assembly Kit—contains the condenser coil with mounting brackets and hardware.

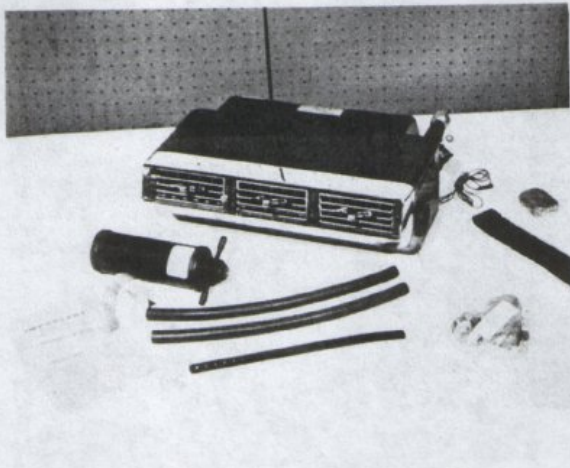

Fig. 71. Typical Evaporator Assembly Kit

- c. Adapter Kit—is sometimes referred to as the mount and drive kit, and contains the crankshaft pulley, idler pulley, compressor mount assembly, bolts and hardware.

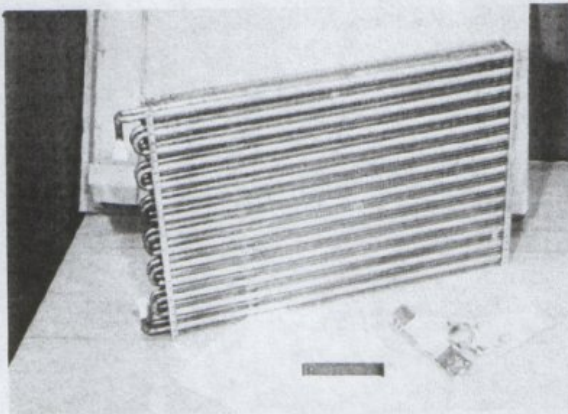

Fig. 72. Typical Condenser Assembly Kit

- d. General Kit—contains the compressor, clutch, refrigerant hoses and hardware.

Basic component packaging might vary from one manufacturer to another, but all components are essential for a complete installation.

Prior to the installation, all the basic kits should be gathered together and inspected. Most manufacturers include a packing list of parts included in each kit, and this list should be carefully checked before the job is started.

Read the instructions before starting the installation. Even though similar installations have been made, the manufacturer may have included modifications or additional parts or instructions. This simple procedure can be a real time saver in the long run.

Be sure to use fender covers and upholstery pads when working on the automobile. Don't leave smudges or prints on the chrome parts. A clean, neat installation will enhance your reputation and increase your future business.

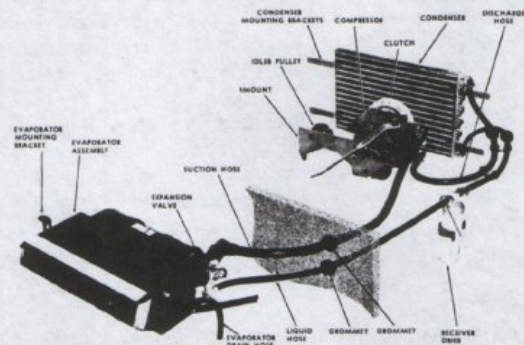

Fig. 73. Typical Auto Air Conditioner Installation

Following are general instructions to be followed when installing air conditioners on any make or model automobile. Detailed instructions applying to specific makes and models are packaged with each unit.

2. INSTALLING THE DRIVE PULLEY:

- a. Disconnect the battery.
- b. Drain and remove radiator where necessary for access to installation of crankshaft pulley.
 1. Save coolant if anti-freeze has been added to the radiator.
 2. Use caution when removing the radiator to avoid damaging the fins and core.
 3. Cap the transmission fluid lines if so equipped.
 4. While the radiator is out of the automobile, it should be checked for cleanliness. If the car has been in service for some time, the radiator

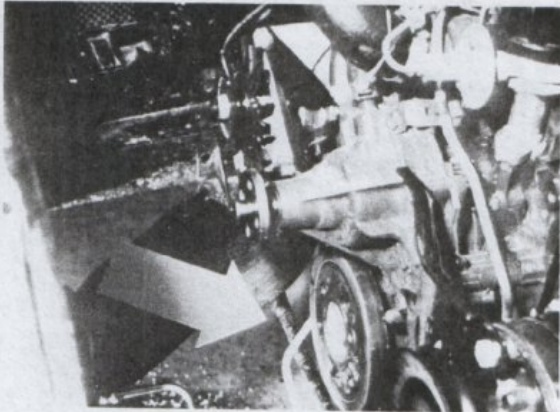

Fig. 74. Original Crankshaft Pulley

might require cleaning and the engine block might have to be back-flushed. Usually the customer will stand this additional expense if the necessity is properly presented and explained to him.

5. Inspect all water hoses and replace if necessary.
 6. Use a pressure cap tester to see if the radiator pressure cap holds the automobile manufacturer's recommended pressure. Replace if necessary.
- c. Remove original crankshaft pulley attaching bolts and install compressor drive pulley on front of original pulley using bolt or bolts supplied in kit, or remove original pulley and replace with pulley supplied.

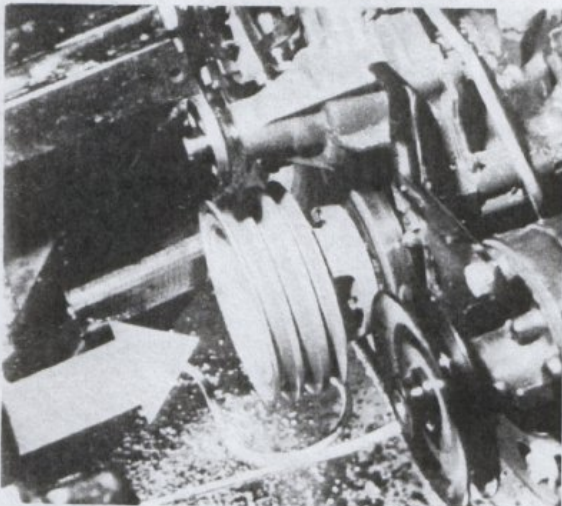

Fig. 75. Replacement Crankshaft Pulley

1. Wipe all dirt and grit from seating and centering surfaces on crankshaft pulley and original pulley hub.

2. Where key is used, make sure the key length is correct and that key is installed properly.
3. Tighten the pulley retaining bolt or bolts securely.
4. If there is any doubt about the accuracy of the pulley mounting, remove the ignition high tension lead and have someone bump the starter several times while you check the pulley for wobble using a straightedge.

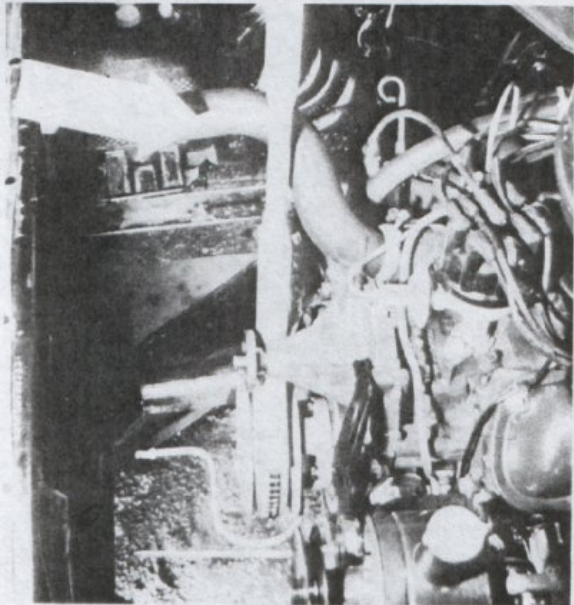

Fig. 76. Tightening Crankshaft Pulley

3. INSTALLING THE COMPRESSOR AND CLUTCH:

- a. Remove the compressor from its carton, and if there is any evidence of oil leakage such as an oily carton or traces of oil around the oil seal or gaskets, the oil level should be checked. Refer to section on oil charges for details.

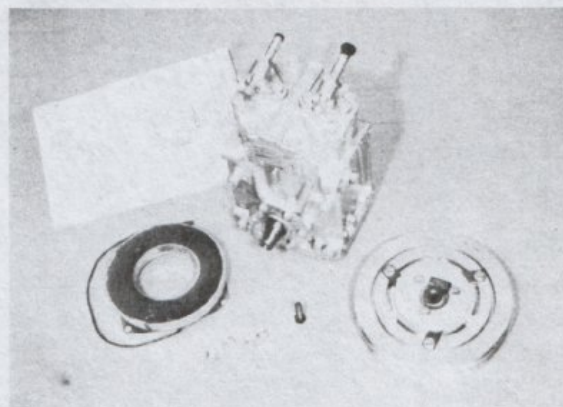

Fig. 77. Compressor and Clutch Assembly

- b. Place the compressor on a bench and install the clutch assembly. Refer to section on clutch installation for details. Specific instructions are also packed with each clutch.
- c. Install the compressor on the mount assembly. Make sure all bolts are drawn up evenly and securely.

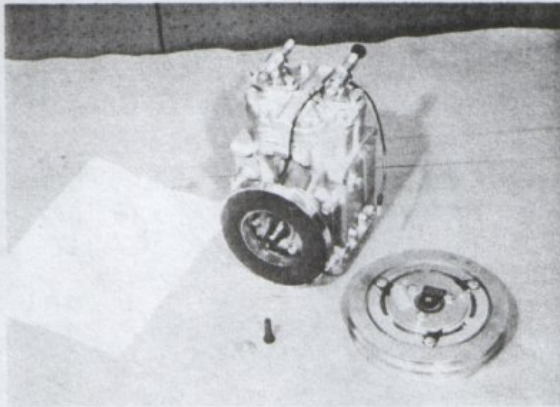

Fig. 78. Clutch Field Coil Installed on Compressor

- d. Clutch power wire will be connected later.

4. INSTALLING COMPRESSOR MOUNT AND IDLER PULLEY:

- a. Install the compressor and mount assembly on the engine using the bolts or studs supplied.
 1. On aluminum block engines use an "anti-seize" compound on all bolts.
 2. To insure alignment with drive pulley, use a metal straightedge against machined forward

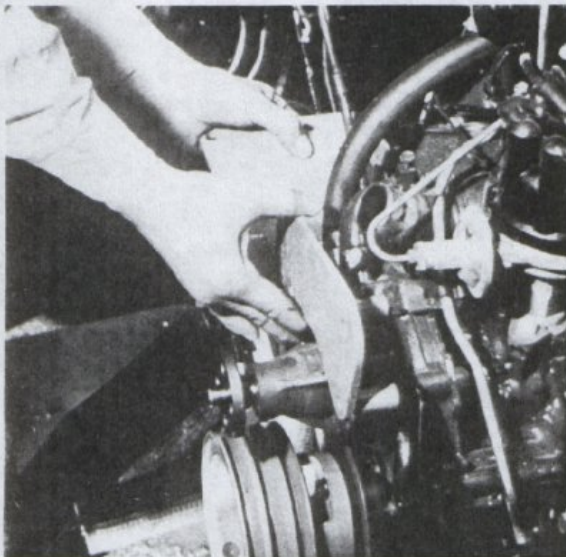

Fig. 79. Checking Fit of Compressor Mount

edges of crankshaft drive pulley and the clutch assembly.

3. Once alignment is correct, tighten all bolts evenly to prevent warpage of the mount assembly.
4. It is possible that some engines may have some holes drilled out of line. If so, it will be necessary to fit the mount as required. This is not the auto air conditioner manufacturer's fault, but rather the result of the engine manufacturer's deviation from standard.

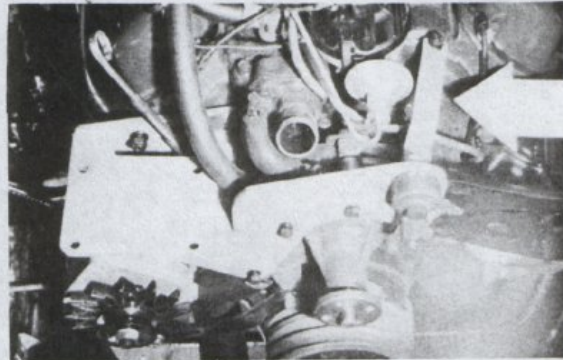

Fig. 80. Compressor Mount, Brace and Idler Pulley Installation

- b. Install idler eccentric and idler pulley as indicated in specific instructions.
 1. Align idler pulley with straightedge, but do not tighten.

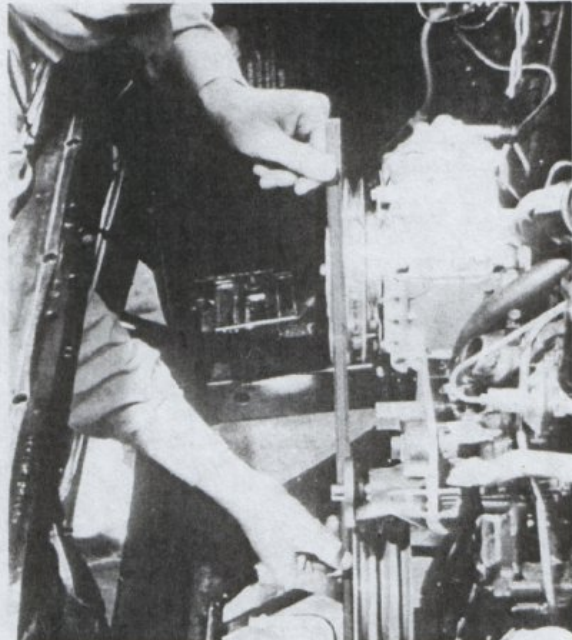

Fig. 81. Checking Drive Pulley and Crankshaft Pulley Alignment with Straightedge

5. INSTALLING THE DRIVE BELT:

- a. Install drive belt around the air conditioning system pulleys as indicated in specific instructions.
- b. Tighten idler pulley.
- c. Belt should not slip when engine is idling and head pressure is approximately 250 psig. Do not over-tighten.
- d. A properly adjusted belt will depress $\frac{1}{2}$ " in the middle of the longest span. If belt tension gauge is used: New belt should be tensioned to 100-125 lbs. and used belts to 80-100 lbs.

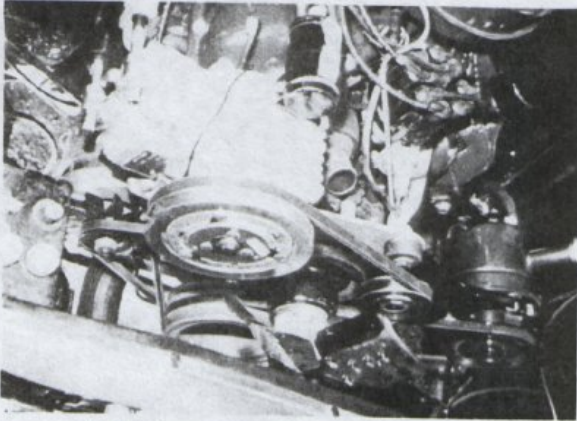

Fig. 82. Compressor, Clutch, Mount, Drive and Belt Installation

- e. Refer to belt section of this manual for additional information.
- f. If at all possible, have customer return car after a week to check belts for proper tension.

6. INSTALLING CONDENSERS:

- a. Place the condenser in mounting position to determine proper mounting.
- b. Install mounting brackets to condenser coil.
- c. Install the condenser.



Fig. 83. Installing Condenser Assembly

1. Rework of some automobile parts may be necessary before installing the condenser.
 2. With the radiator and condenser coil installed, there should be $\frac{1}{2}$ " or more clearance between the condenser and radiator fins.
 3. Be sure to check clearance of the hood latches, grille supports or any accessory in the area which could damage the condenser or restrict air flow.
 4. It is sometimes advisable to attach condenser refrigerant hoses before mounting the condenser. Refer to hose section for instructions.
- d. Check specific instructions. It may be necessary to cut hose routing holes for condenser prior to actual condenser installation.
 - e. Install radiator.
 1. Connect all engine coolant lines and hoses.
 2. Replace coolant.

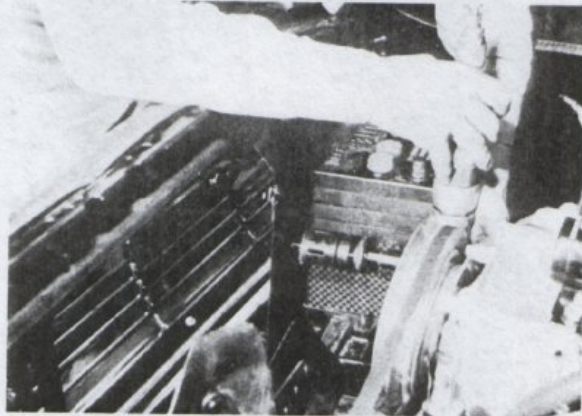

Fig. 84. Drilling Condenser Mounting Bracket Holes

- f. Reinstall original fan or replacement furnished in kit.
 1. Be sure and check clearance between fan and radiator before running the engine.
 2. All units should have at least $\frac{3}{8}$ " fan to radiator clearance.
 3. When engine fan has been refitted, rotate it several times by hand to be sure it runs free and true.

7. LOCATING THE EVAPORATOR CASE ASSEMBLY:

- a. Properly position the evaporator case in the automobile by placing blocks under the drain pan.
 1. Mount the evaporator so it is parallel with the automobile dash, and as exact center as possible but will also clear any accessories.
 2. Removal and relocation of switches or other obstructions may be necessary.

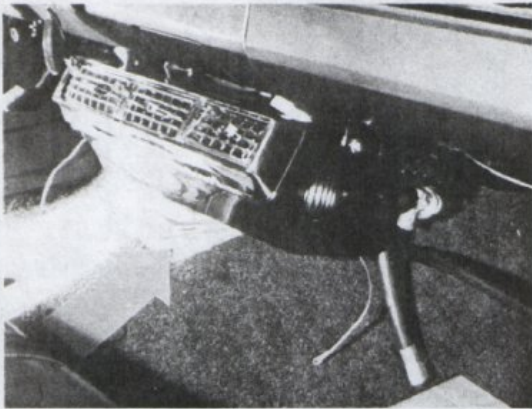

Fig. 85. Locating Evaporator Case Assembly

- b. Loosely attach the mounting brackets and push up against the dash, then mark mounting hole locations.
- c. At this time, also mark drain hose locations on carpet or floormat and refrigerant hose hole locations on firewall with chalk.
- d. Remove evaporator from the automobile.

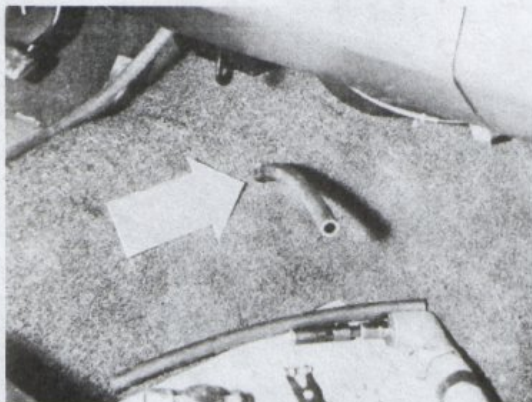

Fig. 86. Evaporator Drain Hose Installation

- e. Locate holes for drain hoses in floorboard behind evaporator case assembly location.
 - 1. Check drain hole location to be sure hoses will not be obstructed on underside of floorboard when installed.
 - 2. On cars with a carpet instead of rubber mat, cut carpet with knife in an "x" pattern. Lift rug at cut to provide clearance for hole saw so that rug will not snag on saw and unravel.
 - 3. Be careful that you do not drill hole in transmission cover.
 - 4. Cut drain holes in floor with hole saw.
- f. Locate holes for refrigerant hoses on firewall.
 - 1. Be sure that hole locations are above engine block, cylinder heads, distributor, etc.

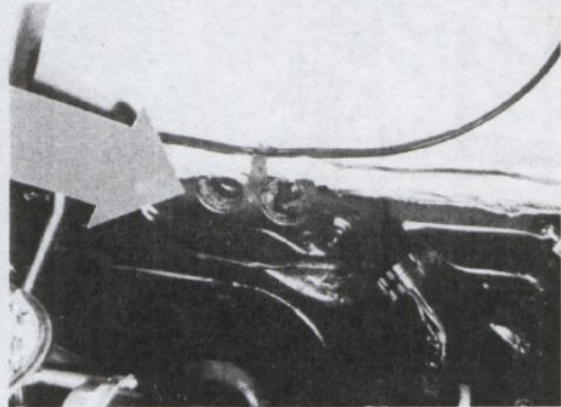

Fig. 87. Hose Routing Holes Drilled in Firewall

- 2. Be careful not to drill holes in radio, heater, and duct work.
- 3. Cut holes in firewall with hole saw.
- g. Drill holes under dash panel for evaporator mounting brackets.
- h. Attach mounting brackets to dash panel.

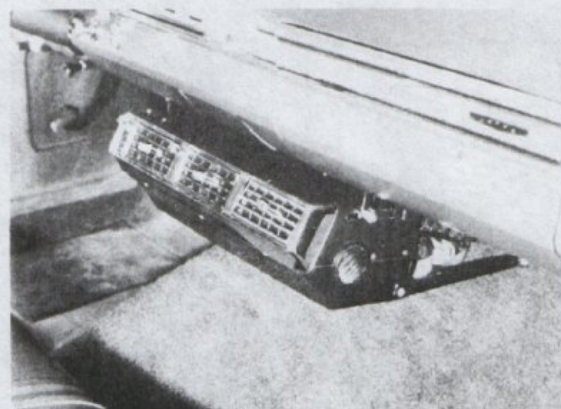
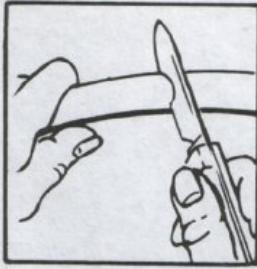

Fig. 88. Installed Evaporator Assembly

8. INSTALLATION OF HOSES:

- a. General:
 - 1. Use refrigerant oil on all hose fittings and connections.
 - 2. Caps and plugs should not be removed until refrigerant hoses are ready to be connected.
 - 3. Avoid sharp bends when installing hose.
 - 4. Do not clamp hoses too close to the compressor so as to restrict movement of the compressor with the engine.
 - 5. Always slide necessary grommets and clamps on hoses before installing.



Cut the hose with a knife.
Do not use hack saw or
similar tools to cut.

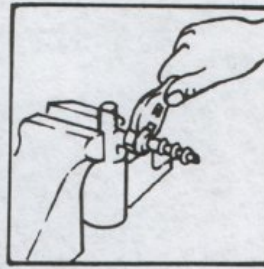

Place drier in vice or similar device
to hold firmly while attaching
push-on fitting.

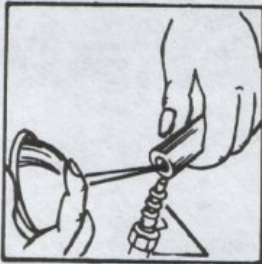

Oil the inside of the hose
and on the nipple. Use
only Refrigerant Oil.

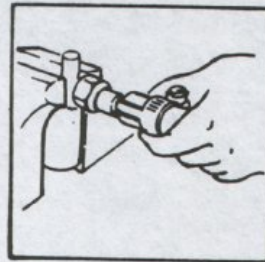

Push the hose with a rotating motion
until it bottoms against the stop bead.

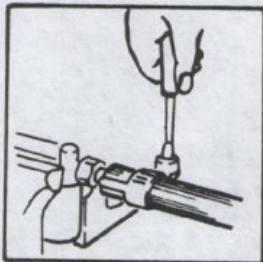

Clamp must be placed so that clip
is over end of hose and flush with
end. This must be done in order
that clamp and fitting make proper
contact. Tighten the clamp to
a 40 ± 3 inch/pound torque.

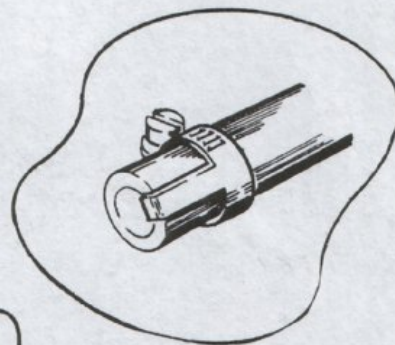

Hose must be against the
Stop Bead

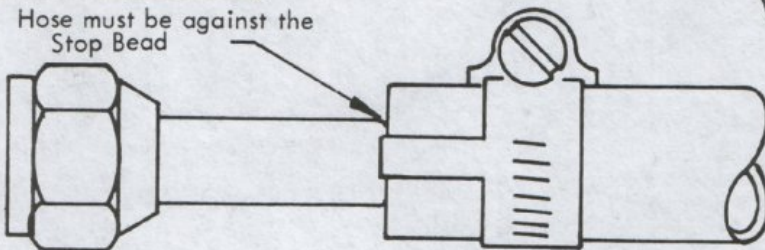

Fig. 89. Push on Fitting Installation Instructions

6. Leave enough slack in hose routing so spring
action of automobile will not pull hose loose
and break connections.

7. Do not use pipe dope or sealants on flare or
hose connections.

8. Always use enough wrenches when tightening

hose connections to prevent twisting or pulling the connection loose.

9. Do not route hoses across battery or hot engine manifold or moving engine parts.
 10. When using push-on hose fittings, carefully follow illustrated instructions.
- b. Install hose from compressor discharge to condenser inlet (upper fitting on condenser.)

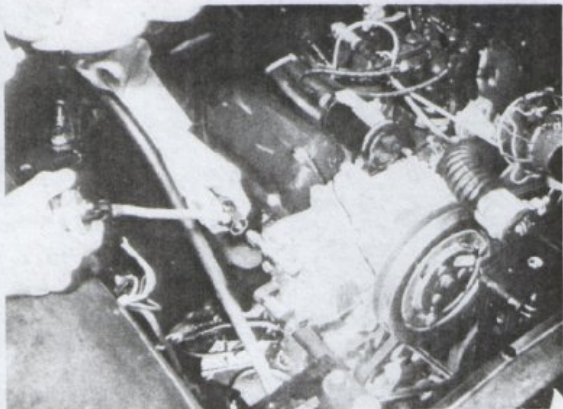

Fig. 90. Applying Refrigerant Oil to Hose Fittings

- c. Install hose from evaporator outlet through firewall to compressor suction.
 1. Seal gaps where hose passes through firewall with a sealing compound.
- d. Insert hose through firewall and connect to evaporator expansion valve.
 1. Seal gaps where hose passes through firewall with a sealing compound.
- e. Locate suitable position for receiver-drier on fender wall of automobile, and secure.
 1. Connect proper hose to condenser outlet and route to receiver-drier location.
 2. Remove plugs or caps from receiver-drier and attach hose from expansion valve to outlet and hose from condenser to inlet.
 3. Make sure all hoses are protected with grommets.
 4. Secure all hoses with clamps.

9. INSTALLING EVAPORATOR CASE ASSEMBLY:

- a. Install evaporator drain hoses.
- b. Mount evaporator to brackets under dash panel.
 1. Route drain hoses through holes in floorboard.

10. INSTALLING ELECTRICAL WIRING:

- a. Connect wiring according to instructions furnished with installation kit.
 1. Make sure wiring is properly protected and insulated from moving parts or hot engine manifold.

2. Tape clutch wire to suction hose.
- b. Connect automobile battery.

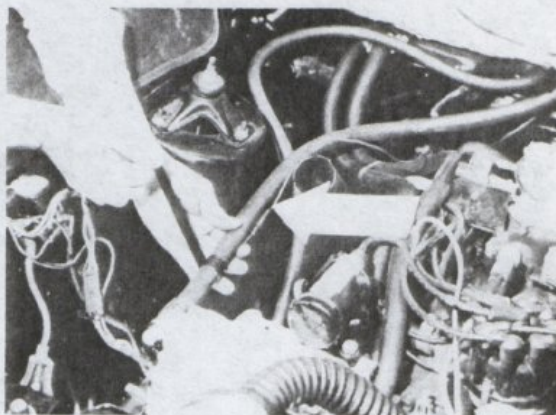

Fig. 91. Taping Clutch Wire to Suction Hose

11. EVACUATING THE SYSTEM:

- a. Refer to section in manual for proper procedure.

12. CHARGING THE SYSTEM:

- a. Refer to section in manual for proper procedure.

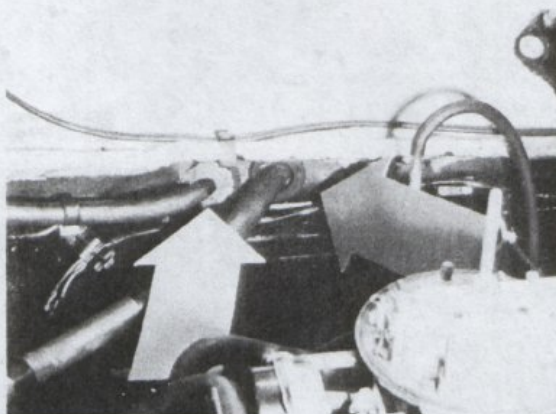

Fig. 92. Sealing Hose at Firewall

13. CHECK-OUT AFTER CHARGING:

- a. Allow engine to run at fast idle and check evaporator outlet temperature. With the car doors open, it should be approximately half of the outside air temperature.
- b. Test for leaks.
- c. Check fan speed control switch for proper operation.

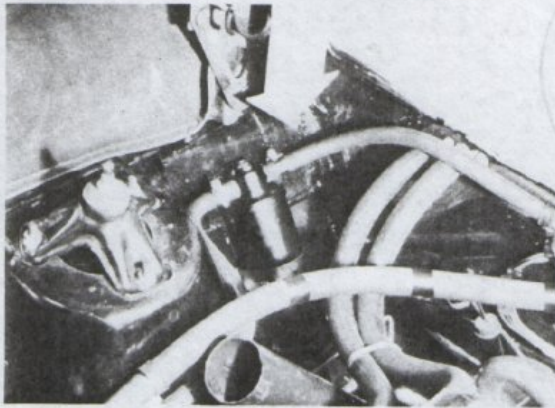

Fig. 93. Typical Receiver-Drier Installation

- d. Check thermostat to be sure unit cycles on and off. This should be done with doors and windows closed. With the car interior cool, the compressor clutch should be made to engage and disengage by moving the thermostat lever.

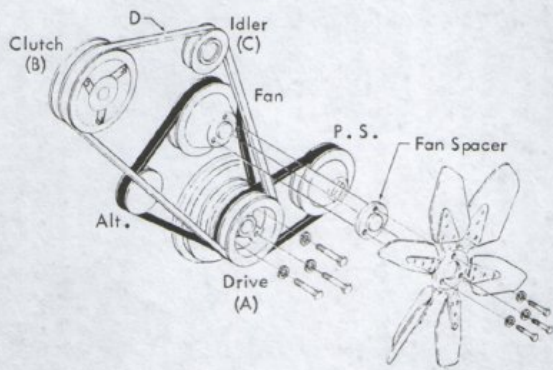

Fig. 94. Typical Belt and Pulley Arrangement

- e. Check clearances between belt, hoses, fan, fan hub, etc.
 f. Road test the car. Be sure and check for engine overheating and noises which may be caused by the installation.
 g. Recheck the belt tension.
 h. Deliver the unit to the customer.

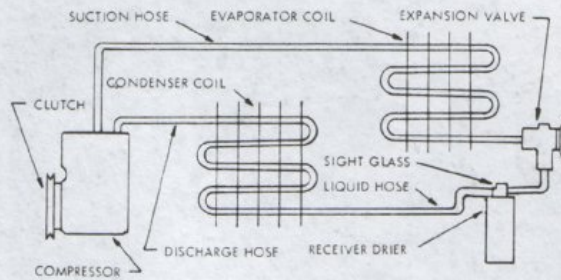

Fig. 95. Refrigerant Cycle Diagram

SERVICE INFORMATION

1. TEST MANIFOLD AND GAUGES:

The gauge manifold set is a multi-purpose tool and can be used in servicing and trouble shooting of the system.

A compound gauge that reads from 0 to 250 psig and from 0 to 30" of vacuum is on the left hand side of the manifold. This gauge is used to read pressures on the low side of the system, and to read in the vacuum range when used for evacuation. The compound pressure gauge should never be connected to the high pressure side (discharge) service valve.

The high pressure gauge is on the right hand side of the manifold. It is graduated from 0 to 500 psig and is used to check pressure on the high pressure side of the system only.

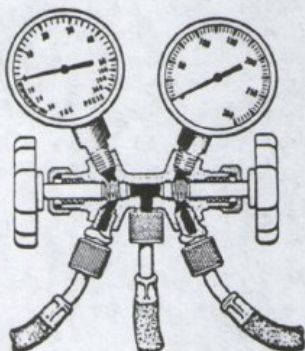

Fig. 96. Test Manifold and Gauge Set

The test manifold has three connections. The one on the left and beneath the compound gauge is connected to the suction service valve. The one on the right and beneath the high pressure gauge is connected to the discharge service valve. The center connection is for the purpose of attaching a line for evacuating, adding and discharging refrigerant. This center connection is common to the other two connections and hand valves on either side of the manifold control flow from the center connection to either or both the suction and discharge service valves.

These hand valves do not close off pressure to the gauges. They only control the openings to the center connection.

2. USE OF GAUGE MANIFOLD SET:

To use the manifold gauge set in diagnosis of pressures in the system, hook up in the following manner:

- a. Close both hand valves on gauge manifold set.
- b. Attach a gauge line to the high pressure connection on the manifold.
- c. Make sure the discharge service valve is backseated. Remove the cap from the gauge port and attach the gauge line.
- d. Attach a gauge line to the low pressure connection on the manifold.
- e. Make sure the suction service valve is backseated. Remove the cap from the gauge port and attach the gauge line.
- f. Crack both service valves and observe the pressures on the manifold gauges.

Some late model compressors are equipped with service valves using the "Schrader" or "Dill" type gauge port fittings, or with this type of valve in place of the complete service valve. It is necessary that the gauge lines be equipped with the "Depressor" type fitting which depresses the valve in the gauge port, which in turn opens the system pressure to the gauge manifold. To remove pressure, simply remove gauge lines from the gauge port.

3. DISCHARGING THE SYSTEM:

Install gauge manifold set and observe pressures in the system. Attach a line to the center manifold connection and place end of line in open can or wrap in waste rags. Slowly open manifold valve and allow system pressure to escape through high side. Rapid release of the pressure in a system will cause oil to foam up out of the compressor. This should be avoided.

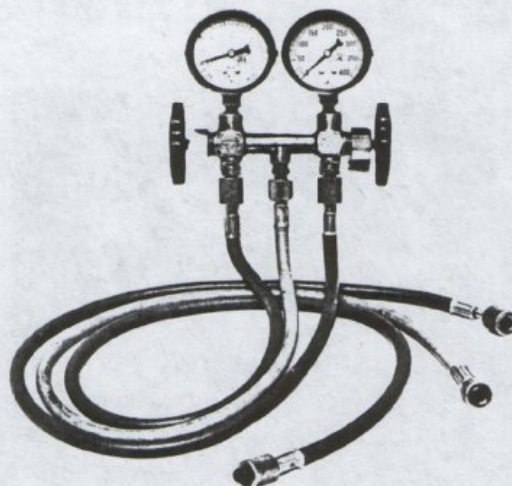

Fig. 97. Manifold and Gauge Set

It is advisable to release the refrigerant charge in an open area, other than where a leak check will later be made. This would prevent contaminating the area with refrigerant gas and causing false leak detection.

The same operation may be performed on the suction service valve to assure complete release of the charge in the system.

4. EVACUATING THE SYSTEM:

Evacuating the system is performed after all components have been installed and all hose connections completed. It should also be performed every time the system has been opened for a service operation such as a replacement of part or line. It is also advisable to evacuate whenever a charge has been lost due to a leak, or prior to charging if the system has been standing for a period of time without a charge.

Evacuation should only be performed with an approved refrigerant vacuum pump designed for this purpose.

Evacuation of an air conditioning system depends upon the ambient temperature surrounding the system and the vacuum pump capacity. Moisture is removed from the system by reducing the internal system pressure to a point where the moisture vaporizes and the moisture vapor is then pulled out to the atmosphere by the vacuum pump. Assuming a vacuum pump of constant capacity, the higher the ambient temperature the more effective your evacuation will be for a given length of time. As an example, moisture in an air conditioning system at an ambient temperature of 60 degrees requires a vacuum of 29.40" of mercury in order to vaporize the moisture. If the ambient is 90 degrees, the moisture will only require the vacuum pump to pull down to 28.50" of mercury for vaporization to occur. The higher the ambient temperatures, the more effective your evacuation will be, and at lower ambients it will be necessary to run the vacuum pump for longer periods to accomplish the same level of moisture removal.

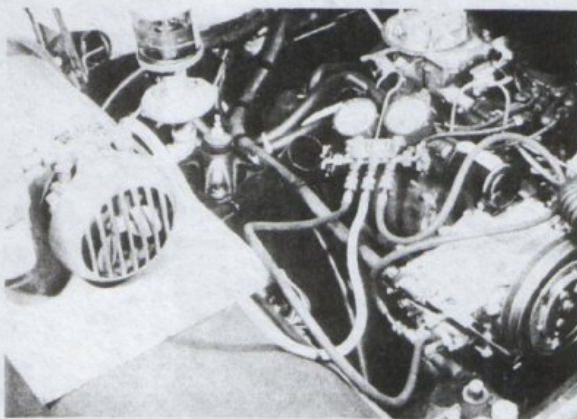

Fig. 98. Evacuating the System

Generally speaking, evacuation of thirty minutes divided into two fifteen minute periods is satisfactory for ambients above 90 degrees. One hour is the minimum

total evacuation time considered safe for ambients below 90 degrees, especially under high humidity conditions.

Evacuation Procedure:

- a. Install manifold gauge set and connect center manifold gauge line to vacuum pump inlet connection.
- b. Place both compressor service valves in the cracked position. (Position that allows you to read gauge pressures.)
- c. Start vacuum pump and slowly open both suction and discharge sides of manifold set. (Open slowly to prevent oil from being drawn out of the compressor crankcase.)
- d. Operate the vacuum pump for 30 minutes. The low side gauge should read between 27 and 29 inches of mercury, and will go no lower. Close the manifold gauge valves and shut off the vacuum pump.
- e. If, in fifteen minutes, the low side gauge pressure rises excessively, the system has a leak. A small rise in pressure might be noted due to the release of trapped refrigerant in the compressor refrigerant oil. It may be necessary to repeat above steps for a short period of time to remove this refrigerant and the resulting pressure.
- f. If the system will not pull down to the proper vacuum, or an excessive pressure rise is noted when the vacuum pump is shut off, a leak is present and must be located and repaired and all steps repeated.
- g. If the system is properly evacuated it is ready for charging.

5. ADDING REFRIGERANT — COMPLETE CHARGE:

A complete charge of refrigeration is added to a system after the system has been properly evacuated and it has been determined that there are no leaks.

Charging Procedure:

- a. Install manifold gauge set.
- b. Connect manifold center port to refrigerant can or drum.
- c. Loosen charging line connection at manifold and open refrigerant can or drum slightly until some refrigerant escapes past the loose connection. This operation will purge any air from the charging line. Tighten charging line connection at the manifold set.
- d. Loosen the manifold hose connection at the suction service valve and open the suction side manifold valve slightly. This operation will purge any air from the manifold suction service valve line. Tighten manifold hose connection at the suction service valve.
- e. Place the can or drum in an upright position and open the can or drum, the suction side manifold valve and the suction service valve. The refriger-

ant gas will now flow into the closed refrigeration system. The first pound of refrigerant will be pulled into the system if a good vacuum has been held on the system.

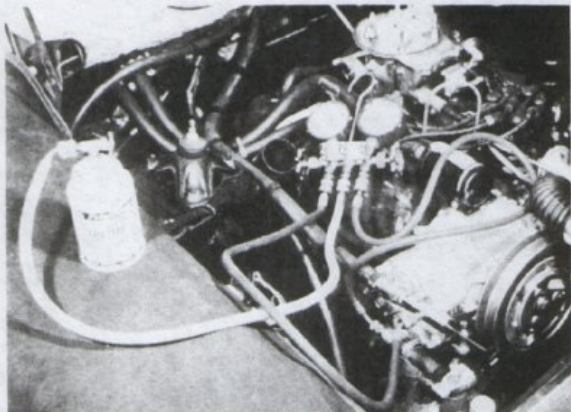

Fig. 99. Charging the System

- f. Start the car engine, set on fast idle, and on hot days place a large fan in front of the radiator blowing directly on condenser coil and radiator.
- g. Connect the second can of refrigerant to charging hose and continue to charge the system. Check the sight glass, and when all the bubbles and foam disappear from the sight glass the unit is fully charged. The system should take between $2\frac{1}{4}$ and $2\frac{1}{2}$ pounds in a fully charged condition.
- h. Low side pressure should read 20 to 40 psig, and high side pressure should read about 180 to 200 psig.
- i. Backseat both suction and discharge service valves. Remove hoses and replace service valve port caps and service valve caps.

6. ADDING REFRIGERANT — PARTIAL CHARGE:

Charging Procedure:

- a. Install manifold gauge set.
- b. Connect manifold center port to refrigerant can or drum.
- c. Purge charging line and manifold line to suction service valve.
- d. Operate the engine and compressor at a slow idle, slowly open refrigerant can valve and allow the compressor to draw the vapor into the system.
- e. Observe the sight glass until a solid liquid column appears. Then add approximately $\frac{1}{4}$ pound more refrigerant.
- f. Close the refrigerant can or drum valve.
- g. Observe gauges, sight glass and engine system for approximately 10 to 15 minutes with engine running at fast idle.
- h. After the unit operates satisfactorily, stop the engine, backseat the service valves, disconnect lines and cap the fittings.

7. LEAK DETECTION:

Refrigerant 12 leaks are detected and located with the help of a device called a Halide Torch. It is much like a gasoline torch, to which has been added an exploring tube through which air is drawn by injector action from points where leaks are suspected.

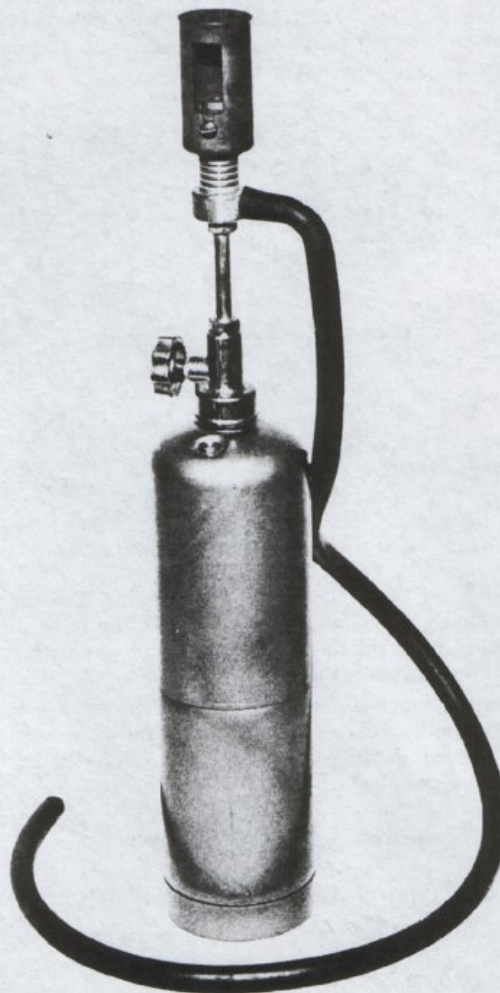

Fig. 100. Halide Leak Detector

Near the place where air is drawn into the flame is a copper reaction ring heated to red hot by the flame. If the slightest trace of Refrigerant-12 comes through the exploring tube, the normally blue flame changes to green, thus indicating that the free end of the exploring tube is being held near a leak.

Electronic leak detectors are also available for use in performing leak checking procedures. Manufacturers' recommendations should be followed.

Always test your leak detector before making a leak check. The system must contain some refrigerant to make the test. If necessary, add a charge so both the compound and pressure gauge reach at least 5 psig.

Go over the system carefully, holding the free end of the exploring tube close to every joint and passing it slowly all around the joint. It takes some time for any escaping refrigerant gas to be drawn through the exploring tube into the torch flame, so this part of the work must not be hurried.

The worse the leak, the greater the concentration of refrigerant carried into the torch, the darker will be the green on the torch flame. Large leaks may turn the flame to a bright purple or even extinguish the flame by keeping air and oxygen from it.

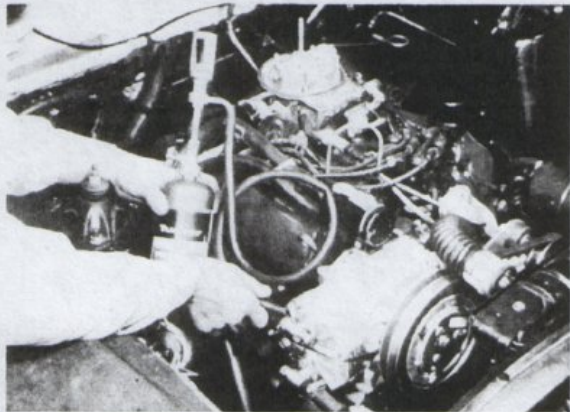

Fig. 101 Leak Testing the Installation

With very large leaks, the surrounding air may be saturated with so much refrigerant that the torch flame remains green all the time. This could easily happen when there is poor ventilation.

Do not run the air conditioner or the engine while performing a leak test. Any circulation of air around the system joints could wipe the refrigerant traces away before being detected.

Once the leak has been detected, it must be repaired and the system evacuated and recharged.

8. PURGING AIR FROM THE SYSTEM:

Air consisting of gasses that cannot be condensed in the refrigeration system causes excessively high pressures in the high side of the system and reduces operating efficiency.

The presence of air is always indicated by high head pressures. No matter where or how air enters a system, it will always end up in the condenser. Air mixes with the refrigerant vapors in the condenser and takes up valuable condensing space.

Air in a system causes high head pressure and an excess of refrigerant will also cause high head pressures. It is possible to confuse the two causes because the symptoms are alike. However, if air is present when the system is shut down, the high head pressure as indicated on the manifold gauge will fall rapidly; if there is too much refrigerant in the system the pressure will fall quite slowly.

Purging Procedure:

Allow the system to remain idle for 1/2 hour after the compressor has been operating. The air can then be released through the discharge service valve, or any other convenient high point in the system where high pressure gas would normally be present.

Cover the gauge port with a cloth when purging to prevent refrigerant or oil from contacting persons or the car. Purge slowly for only several seconds at a time to prevent drawing too much oil out of the system.

After you feel that the air has bled off to the atmosphere, close the system and operate the engine and the air conditioner. Observe the gauges and check to see if the system is operating satisfactorily.

If the system pressures are now normal, you have been successful. If not, repeat the procedure.

Sometimes it is not possible or practical to bleed the system or air, in which case you must discharge the refrigerant, pull a vacuum and recharge.

9. PURGING EXCESSIVE REFRIGERANT FROM THE SYSTEM:

Install the gauge set and operate to determine pressures. An excessive amount of refrigerant will be indicated by high head pressure, although the cooling effect is adequate.

Bleed the extra refrigerant through the discharge service valve and manifold charging line. Bleed slowly to prevent the oil in the system from foaming and being pulled out of the system. When bleeding off refrigerant, a cloth placed over the charging line outlet will prevent refrigerant or oil from splattering on the car or persons.

After bleeding what you feel is the correct amount, operate the system and observe the sight glass and operating pressures.

It may be necessary to purge additional amounts or to recharge to the correct point.

10. CHECKING AND ADDING OIL:

During normal operations, a small amount of oil is always circulating throughout the refrigeration system. The oil level is determined by stopping the compressor and closing the suction and discharge service valves to the lines. This isolates the compressor from the rest of the system, and leaves the system sealed from the atmosphere.

Loosen the gauge port cap on the discharge service valve slightly, and let the gas in the compressor purge the air slowly until the pressure is relieved. Relieve the crankcase pressure by loosening the oil filler plug slowly and remove.

Add oil to bring to the recommended level if necessary. To avoid adding too much oil, add slowly and check with dip rod.

Replace the oil filler plug. Crack the suction service valve slightly until a hissing sound is heard from the valve to allow the system to purge air from the compressor through the discharge service port.

Tighten the discharge service valve port cap, back-seat both service valves and put system in operation.

In the event the compressor is equipped with "Schrader" type valves, you must discharge the complete refrigerant charge to the atmosphere and recharge after adding oil.

11. NEW SYSTEM CHECK OUT:

After the air conditioning unit has been installed, make a final check for proper installation. Check all refrigeration hoses for proper hook-up and routing. Make sure all connections, bolts, screws and clamps are secure.

If condenser coil fins are bent, comb out with fin comb.

Start engine and run unit, check sight glass for bubbles and foam. While unit is running, move thermostat switch to cold position to see that clutch is engaging and disengaging properly.

Check and align belts and pulleys if necessary. Make sure that hoses and electrical wires are properly protected from sharp edges or hot engine manifold, and will clear any moving engine parts. Check radiator coolant level.

TROUBLE SHOOTING

1. GENERAL:

When the owner of an automobile air conditioner drives his car into your service center for your help, his complaint will usually be of a general nature. Usually his complaint will be that he has no cooling, not enough cooling, intermittent cooling or that the system is noisy. From this point, the serviceman must make use of his specialized knowledge to isolate the cause and take the necessary steps to put the air conditioner back in operation.

The serviceman can only read his pressure gauges, look, listen and feel the unit. With the information he obtains in this manner, he must add his specialized knowledge and come up with the proper answers.

A thorough knowledge of the basic principles of air conditioning and the actual mechanical know-how are both necessary to make a service diagnosis. Often a malfunction in one part of the system will only show up as a symptom elsewhere. A serviceman must have a nimble, open mind to penetrate right to the heart of the problem quickly, thoroughly and efficiently.

For any one complaint, there are usually at least a dozen possible causes. Each possible cause must be eliminated. Many possible reasons for failure can be eliminated by just a feel or glance, and to save time the serviceman should always work from the fastest and most obvious reasons for failure down to the most time consuming and intricate tests.

Only experience will give the serviceman the confidence and ability to service the air conditioning system in this manner. Each mistake or wrong diagnosis serves its purpose in that the same error won't be committed a second time.

Following is a list of possible causes of failure, with a discussion of each. As you will see, all the parts and causes are inter-related and the serviceman must always bear this in mind when working on a system. Don't get on a one-thought track and not be able to see other possibilities when performing service work.

2. BELT TROUBLES:

A visual inspection will enable you to determine if the belt is missing, broken or slipping. Sometimes the failure of a belt is merely due to being worn out over a period of time. A loose belt most often is because of age and fatigue. When a belt is retightened, you should check the mounting brackets to see if they have shifted, and also the pulley grooves to see if they are worn. Replacement of the belt may be necessary and possibly the crankshaft pulley and clutch, due to excessive wear. Misalignment of pulleys can cause belt failure and pulley groove wear. A belt may have been forced onto the pulley upon installation, which could cause broken cords. Or perhaps the engine has thrown oil on the belt or pulley and caused slipping or pre-

mature failure. The correct belt tension is very important, as overtightening can cause compressor and clutch bearing failure and compressor seal failure.

Many times a broken or slipping belt is only a symptom and not the real cause of insufficient cooling. If the system contains too much refrigerant, the condensing head pressure will be too high, which in turn makes the compressor try to pump against this excessive head pressure and slipping belts may result. In fact, excessive head pressure from any source can cause slipping and wearing on belts and pulleys. The serviceman should always investigate the possibilities of dirty condensers, air in the system and refrigerant overcharge if belt problems are encountered.

3. VIBRATION OF COMPRESSOR AND MOUNT:

Most vibration problems are due to loose or broken bolts, mounts or braces. A careful visual inspection will usually pinpoint the problem. Sometimes the problem is solved at this time, and sometimes it is necessary to make a further check to determine if the failure of a bolt, brace or mount is due to other malfunctions in the system. High condensing pressure can put an extra load on the compressor, with this pressure in turn transmitting the load through the power train to pulleys, belts, mounts, bolts and braces. This high head pressure can also cause failure of bearings and misalignment of pulleys and clutches.

A compressor will become noisy if it is low on refrigerant oil. Periodic maintenance will usually prevent this problem.

4. NOISY CLUTCH:

Clutches that operate but are noisy probably have loose mounts, bolts, or worn or defective bearings. There are instances where noise is due to the clutch engaging and disengaging too often. This could be caused by the thermostatic switch losing its calibration and pulling the clutch coil in and out of the circuit too often.

Defective or worn clutch bearings could be due to normal wear, or it could be caused by misalignment of the pulley or mounts, shifting or failure of braces.

5. NOISE COMPLAINTS:

Many of the noise complaints can be traced to mount and drive and other related component problems. Normally, if the unit is noisy at one speed and this noise clears up at another, it is not usually due to the compressor. Each vehicle has its critical frequencies where all vibrations get into the correct harmony to generate sound or noise. The speed at which these critical points are found will vary with each vehicle and each mount and drive arrangement. Many times noise generated

due to this condition can be eliminated or greatly reduced by changing the belt adjustment to a different torque. A torque of 100 ft. lbs. is considered the normal belt tension. Excessive belt torques tend to destroy bearing, belts and idlers, so refrain from over-torquing of belt. Replacement of a compressor which produces noise at the same time that the belt seems to "dance" or "jump" will not usually correct the noise problem. Usually rigidizing mounts, addition of idlers or changing belt adjustment and/or length are more successful in removing or reducing this type of noise level. Changing discharge hose length is often effective in "tuning" or reducing sound level.

Certain body styles and models of cars seem more difficult to quiet than others. Many things can cause this to be true. In many cases, the frequencies caused by the compressor operation excite and amplify the normal frequencies of related components. Some people describe this type of sound as "motor boat noise" or "moan" type of noise. They normally appear and disappear at different motor car speeds or frequencies. These problems are difficult to eliminate completely, but they may be greatly reduced by the changing of any of the following: (1) mount and drive components, (2) changing of length and routing of discharge line, (3) isolating the condenser from the radiator yoke, (4) or adding a discharge line muffler as close to the compressor as possible to dampen the frequencies generated by the compressor operation.

Noise emanating from the clutch is difficult to recognize because of the close connecting feature with the compressor. A loose bolt holding the clutch to the shaft will result in extremely noisy operation. Extreme care must be exercised to prevent the removal of the wrong component.

The differential between the suction pressure and the discharge pressure also plays an important part on sound level. A compressor with a low suction pressure will be more noisy than one with a higher back pressure. Likewise, high head pressures tend to make compressors noisy because of the additional loading on bearings. Things which should be taken into consideration are whether the system is properly charged, whether the expansion valve is feeding properly to use the evaporator efficiently and whether sufficient air is being maintained over the evaporator coil. On the high side, we should check for non-condensibles in the system as well as cleanliness of condenser, amount of air that can flow through it, and overcharge of refrigerant.

Since a compressor has many moving parts, it is normal for it to generate some noise just as a motor generates some noise as it is operated. The refrigerant gases, as they are moved by the compressor pistons, also produce noises and vibrations as a normal situation.

The level of permissible noises varies with the customer, and generally an explanation how the compres-

or functions and what it does serves to satisfy a customer, that since the compressor is doing work it is natural for it to make some sound.

6. HIGH ENGINE TEMPERATURE:

High engine temperature is a symptom and not a cause in an auto air conditioning system. It is always caused by something else. Most of the time these problems are not directly attributable to the air conditioning system, but the tendency of the owner is to think so and bring his automobile to you for service. Common causes of high engine temperature are loose fan belt, dirty radiator, crimped or defective radiator hose, dirty cooling system, bad engine timing, too small fan, too small radiator or defective radiator pressure cap.

On factory installations of automobile air conditioning systems, some car manufacturers furnish heavy duty radiators to prevent engine overheating. This same radiator is available as an option for aftermarket installations. If this option is not taken advantage of when installing a field unit, overheating may result and the only method of correction would be with an oversize radiator.

Some field installations also require an oversize fan blade in order to prevent engine overheating.

7. CLUTCH DOES NOT OPERATE:

Any time an electrical part on the system does not function, the serviceman should always check the circuit fuse first. Again, a blown fuse is only a symptom and not a cause, therefore further investigation is necessary. Before any electrical circuit can be traced for troubles, every precaution should be taken that a circuit is possible and not be due to blown fuses, broken wires or loose connections. A lot of needless time and expense will result unless these simple inspections are made first.

If a clutch does not operate and the trouble does not lie in blown fuses or broken circuits due to loose or broken wires, the clutch itself should be checked for grounds, shorts and opens, worn brushes or defective retracting springs.

Perhaps the thermostatic switch that makes and breaks the clutch circuit is stuck in an open position, or the power element has lost its charge. Under normal circumstances it is fairly simple to determine if an electrical circuit exists, or if not — where the open is located.

8. BLOWER DOES NOT OPERATE:

Again, fuses and broken circuits due to loose or broken wires should be checked first. If the circuit is still not complete, the motor itself, the blower switch or perhaps the resistor on the blower switch should be checked.

The blower motor should also be checked physically to see that the fan blade or blower wheel is not out of line and stuck against the shroud or scroll.

9. BLOWER RUNS TOO SLOW:

This problem could be due to loose wires, shorts in the motor windings, binding shafts or wheels, or bad motor bearings.

10. NO COOLING:

This is a common and universal complaint. A customer brings his automobile to you and says the air conditioning system is not working. A logical step by step procedure is necessary in order to save time and expense and get to the heart of the problem at once.

A quick visual inspection is the first step. By just looking closely at the system, you can see if you have a blown fuse, loose or broken wire, bad belt, broken or defective refrigerant hose, or leaking compressor seal. Perhaps after this visual inspection you have located the trouble. If not, you should see if the system will operate and not cool. If the system will not operate, a further check of electrical continuity should be made, and perhaps a bad switch, resistor, clutch or motor will be found.

If the system runs but does not cool, the manifold gauges should be installed and pressure within the system observed. By observing operation pressures, defects within the refrigeration system can be singled out. Gauge readings will indicate such things as a leak, inefficient compressors, defective expansion valves, and clogged screens. Refer to the section on abnormal gauge readings for further information.

11. NOT ENOUGH COOLING:

When a customer drives in and says that he does not have enough cooling, at least you know that he has some cooling and that the electrical circuits are in working order. Again, a visual check should be made for slipping belts, broken hoses, clogged condenser, or leaking compressor seal.

If this check does not reveal the trouble, a more intensive check of a slipping clutch, binding blower motor, restricted condenser or evaporator coil must be made.

Perhaps the only trouble with the air conditioning system is under-capacity due to driving with vents or windows open. Be sure to question the owner on this point.

If the problem has not been located as yet, the manifold gauges must be installed and further check made as to the proper operation of compressor, expansion valve, or other refrigeration controlling devices. The gauges may indicate a shortage of refrigerant, a freeze-up at the expansion valve, or a restricted line or drier. Refer to the section on abnormal gauge readings for further information.

It is also possible that the thermostat is out of calibration and shuts the system off before the proper temperatures are reached.

12. INTERMITTENT COOLING:

This complaint tells you that the system either is operating inefficiently or intermittently. Build up of ice on the evaporator coil is the usual cause of this problem. This build up can be caused by the right combination of humidity conditions, in which case the proper advice in operating procedures is the only answer. Sometimes icing can be caused by defective regulating devices in the refrigeration circuit or a thermostatic switch out of calibration.

Other causes in the electrical circuit can be defective circuit breaker, blower switch, a partial open ground or loose connection in clutch, blower motor or switch. Or the clutch could be disengaging prematurely or be slipping due to belt or misalignment problems.

In some cases, the refrigeration system will have to be investigated for freeze-up or improper adjustment of the expansion valve.

13. HIGH CONDENSING PRESSURE:

A high head pressure reading is a symptom and not a cause of trouble. When this is observed, you must locate the real trouble and fix it before additional damage is done to the system.

When the condensing pressure is too high, it may be caused by something external that a visual inspection will detect — such as a blocked or dirty condenser surface. Or you may have to determine if you have air in the system, an overcharge of refrigerant, a kinked discharge hose, or too much oil in the compressor.

14. LOW SUCTION PRESSURE:

If there is a shortage of refrigerant in the system it will cause a low suction pressure. This can be determined by checking the sight glass. If there is a shortage of refrigeration, again it is only a symptom and not a cause and the system must be checked further for damaged hoses, compressor gasket or seal leaks and loose fitting connections.

When the charge is sufficient, it is a possibility that there could be a restriction to refrigeration flow in the drier or other strainer in the system.

The compressor itself might have leaking suction valve reeds, and thus not be able to pump the refrigerant around in the system. The expansion valve may be stuck in an open position, or the bulb might be loose or incorrectly located.

If there is a build up of ice on the evaporator coil, the air flow will be restricted and a low suction pressure will be the result.

The thermostatic switch may be out of calibration, or there might be moisture in the system causing a freeze-up at the expansion valve.

SERVICE TOOLS

1. GENERAL:

Most of the tools necessary to install and service the automobile air conditioning system are already to be found in the automobile mechanic's tool box. There are certain tools that are specialized and peculiar to the refrigeration and air conditioning business only.

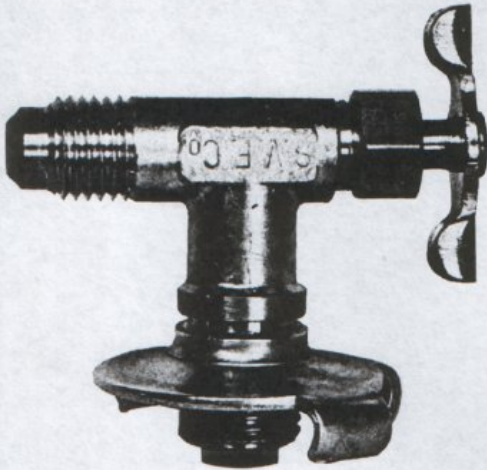

Fig. 102. R-12 Can Adapter Valve

It is essential that these tools are obtained and the accompanying instructions understood before use.

2. SPECIAL AUTOMOBILE AIR CONDITIONING TOOL LIST:

<i>Frigiting Part No.</i>	<i>Description</i>
49-00015	Vacuum pump
07-20022	Halide gas leak detector kit
*49-00031	G.E. electronic leak detector
07-90018	G.M. compressor tool set
*55-00162	"Dial-A-Charge" charging cylinder
61-21035	R-12 Can adapter valve
07-20042	Charging and testing gauge and manifold set
07-20040	36" charging lines
07-20025	Tubing cutter
*07-20119	Schrader type valve tool
07-20035	Mighty tork pulley wrench
07-20024	Flaring tool
91-00806	Serviceman thermometer
07-20036	1/4" Reversible ratchet
*Optional	



Fig. 104. 1/4" Reversible Ratchet Wrench



Fig. 103. G.E. H-10 Electronic Leak Detector

PERIODIC MAINTENANCE GUIDE

1. OWNER MAINTENANCE:

In order to obtain maximum performance from his air conditioner, you should instruct the owner to periodically check the condenser and car radiator for bugs, dirt and leaves. The space between the condenser and the radiator should also be checked for obstructions. Usually a thorough hosing down when the automobile is being washed will keep these finned surfaces in a clean condition.

The owner can also check for proper belt tension or failure if he so desires. He can also visually check connecting hoses for damage or obstructions.

Care should be taken that the owner is instructed to operate his automobile air conditioner for five or ten minutes monthly during winter months. This is necessary in order to keep the compressor oil seal lubricated and to prevent premature seal failure and loss of refrigerant.

2. SERVICE CENTER MAINTENANCE:

A service center check of the automobile air conditioning system should be performed each spring and fall or every 10,000 miles on high mileage cars. This check should be made with preventive maintenance in mind, and most checks are of a visual nature unless such a check turns up additional problems.

A check should be made for clean condensers and radiators, belt condition and tension, refrigerant hose and connections, compressor oil level and refrigerant charge.

While the automobile is in your shop you should also make a quick check to determine if there is proper air flow across the evaporator, and if cool air is being delivered in the proper quantity.

SAFETY PRECAUTIONS AND PRESSURE TEMPERATURE CHART

1. PRECAUTIONS WHEN HANDLING REFRIGERANT:

1. The skin and eyes should be protected from contact with refrigerant liquid or vapor. A small bottle of mineral oil and of boric acid should be located near the service stall. Should refrigerant contact the eyes, wash immediately with a few drops of mineral oil followed by a thorough cleansing with a weak solution of boric acid. See a physician if irritation continues. Should liquid refrigerant come in contact with the skin, the injury should be treated the same as though the skin has been frost-bitten or frozen.
2. In the presence of an open flame, Refrigerant-12 produces Phosgene gas. This is very poisonous — never breathe it.
3. The charging drum should never be subjected to excessive temperature when charging a system. The drum can be heated by placing in 125°F water if necessary. Do not heat above 125°F or use a blow torch or other open flame to heat the drum.
4. Always replace the drum cap immediately after use to protect valve and fusible plug from damage.
5. Never over-fill a refrigerant charging cylinder. Leave room for liquid expansion, or pressures can be built up that will cause the drum to burst.

2. PRECAUTIONS WHEN USING SERVICE TOOLS:

1. Be sure gauge manifold hoses are in good condition. Never let them come in contact with engine fan or exhaust manifold.
2. When disconnecting any fitting in the refrigeration system, proceed very cautiously regardless of gauge readings. If pressure is noticed when fitting is loosened, allow it to bleed off slowly.
3. Always use two wrenches when tightening or loosening refrigerant line fittings. The opposing fitting should always be held with a wrench to prevent distortion of lines or components.
4. Tools should be kept clean and dry. This includes the gauge set and replacement parts. Keep gauge lines plugged when not in use.

3. PRECAUTIONS WHEN INSTALLING AN AUTO AIR CONDITIONER:

1. Wear goggles when using a hole saw or portable jig saw.
2. Use caution when drilling holes in the automobile. Holes drilled into electrical wiring or into the gas tank can cause fire or explosion.
3. Be sure all cap screws are tight and of the correct length. Pulleys coming off at high speeds can cause damage to the automobile or injury to the occupants.
4. Make sure refrigerant hoses are clamped so they cannot come in contact with any sharp metal, or with the engine fan or manifold.

4. PRECAUTIONS WHEN SERVICING AN AUTO AIR CONDITIONER:

1. Keep hands clear of the automobile engine fan and belts when the engine is running. This should be considered when opening or closing the compressor service valves.
2. Use caution when working around exposed evaporator or condenser coil fins. Painful lacerations can be inflicted by the fins.
3. Keep hands away from moving fans and blower wheels. High speed motors have enough power to cause injury.
4. Never close the compressor discharge service valve when the unit is in operation.

5. PRECAUTIONS TO KEEP SYSTEM (CLEAN AND DRY):

1. Cap all open lines, ports and connections immediately. This prevents the collection of moisture and dirt or foreign matter from entering the system.
2. Make sure the oil container is sealed and capped when not in use.
3. Do not allow the system to remain open any longer than necessary.
4. Never use a receiver-drier which has been left uncapped or open to the atmosphere.

*Evaporator Temperature	Evaporator vs Pressure	**Condenser or Ambient AIR Temperature	vs	High Pressure Gauge Reading
-25°	(2.3)			
-21°	0 (Atmospheric Pressure)	20°		45
-20°	0.6	30°		55
-15°	1.7	40°		72
-10°	4.5	50°		86
-5°	6.8	60°		105
0°	9.2	70°		126
5°	11.8	75°		140
10°	14.7	80°		160
15°	19.1	90°		185
20°	21.1	95°		195
22°	22.5	100°		220
24°	23.9	105°		240
26°	25.4	110°		260
28°	26.9	115°		275
30°	28.5	120°		290
40°	37.0	125°		305
50°	46.7	130°		325
60°	56.1			
70°	70.1			
80°	84.1			
90°	99.6			
100°	116.9			
110°	136.0			
120°	157.1			
130°	180.2			

***NOTE:**
 All temperatures in °F.
 All pressures in Lbs/sq. in. gauge (PSIG)
 Figures shown in () are in inches of Mercury Vacuum

****NOTE:**
 All Temperatures in °F.
 All pressures in Lbs/sq. in. gauge (PSIG)
 All values determined with following conditions:
 (a) Compressor Speed = 1750 RPM
 (b) Condenser Air Volume = 1565 CFM
 Evaporator total heat load = 18,442 BTU/hr.
 (c) Conditions equivalent to 30 MPH or Fast idle with auxiliary Fan to simulate ram air.

Table 8. Pressure Temperature Chart

