



VOLVO

WORKSHOP BULLETIN

CARS

RE:	OIL TRAP B 20	PRODUCT	P
		GROUP	21
		NO.	12
DATE	June, 1969		

New oil trap for B 20 engine

The pipe dimension on the oil trap connection to the engine block has been increased from diameter 22 mm (0.87") to 27 mm (1.06").

This reduces the through-flow speed and prevents oil coating.

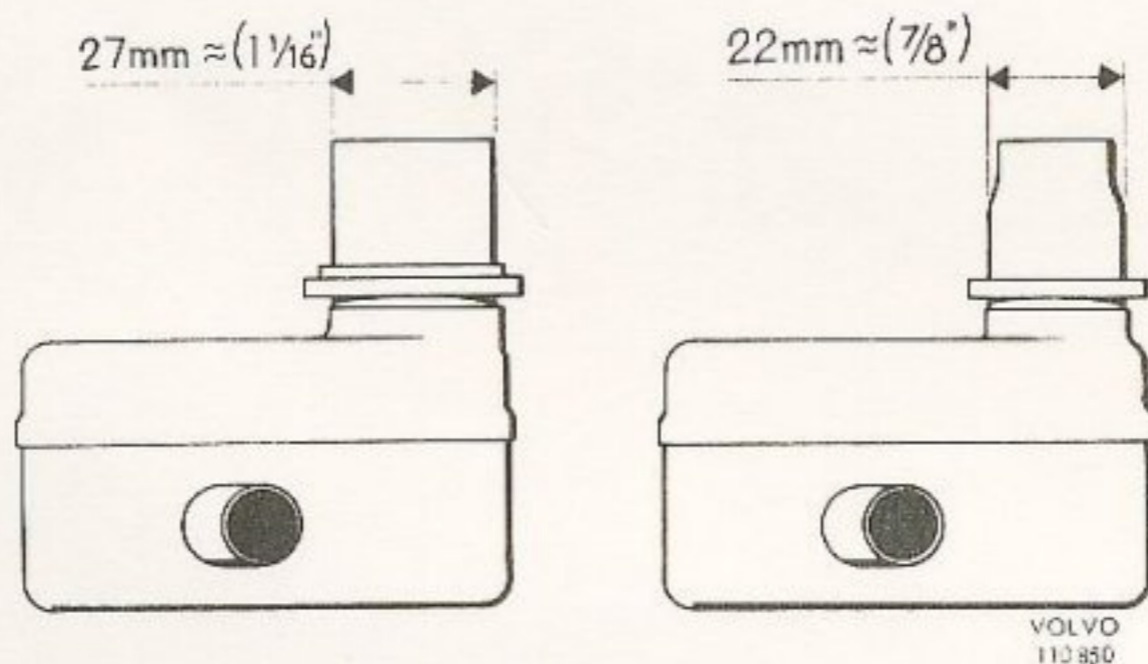

Late prod.
part No. 419808

Early prod.
part No. 419743

The sealing ring for the new oil trap has part No. 419805.

The oil trap is introduced into engines as follows:

<u>Engine type</u>	<u>Engine No. with effect from</u>
496900	13968
496901	311
496905	3667
496910	1667
496911	1118
496912	22308