



SPECIAL TOOLS

CARS



FOREWORD

This Tool Catalogue is divided up into two parts, the first of which consists of a list of all the tools used on our car models with effect from PV 544. The second part consists of illustrated lists in which the tools are arranged by sections, i.e. engine, power transmission, brakes, etc., on the same lines as in our Service Manuals. Note, however, that the illustrated lists only include tools for vehicles in current production. For other vehicles, please refer to the tool illustrations in the Service Manual concerned.

The tool list in the first part is arranged in numerical order. The "X" markings in the vehicle model columns show which tools are used on the vehicle concerned, and the numbers in the "Part" column show the service manual parts in which the tool concerned appears i.e. 2 for engine, 41 for clutch, etc. From the "Alternative product" column it can be seen whether the tool is also used on trucks and/or buses. At the end of the tool list an empty page has been left on which we suggest you note new tools as and when they are introduced on Workshop Bulletins.

The numerical tool list is normally used when looking up all special tools for a particular vehicle model. If, on the other hand, it is only required to look up the tools for a particular engine, gearbox, etc., it is quickest to consult the illustrated lists. To identify a tool by means of the SVO number only it is best to use the numerical list. If it cannot be found there, it is probably a tool which is only used on trucks or buses, in which case please refer to the Tool Catalogues for these products.

AB VOLVO

GOTHENBURG - SWEDEN

CONTENTS

Numerical Tool List

SVO	page
1171-1805	3
1806-2227	4
2228-2302	5
2303-2385	6
2386-2414	7
2415-2456	8
2462-2537	9
2538-2612	10
2684-2712	11
2713-2733	12
2734-4025	13
4028-4113	14
4118-4158	15
Illustrated Lists	17

NUMERICAL TOOL LIST

SVO	DESCRIPTION and use	Alt. product	Part	120-series	140-series	1800	P210	PV544	Notes
1171	KING PIN BUSHING REAMER, 19 mm diameter, for reaming king pin bushings		6				X	X	For machine reaming, see SVO 2545
1221	PLIERS for lower spring, rear wheel brakes, early production		5	X					
1340	DRIFT for removing and fitting gudgeon pin (B 16)		2	X			X	X	
1355	DRIFT for bushing in connecting rod (B 16)		2	X			X	X	
1356	PRESS TOOL, M24 x 1.5, for camshaft gear and belt pulley (B 16)	B L	2	X			X	X	
1426	DRIFT for fitting ball bearing in flywheel (B 16, B 18)	L	2,41	X	X	X	X	X	
1428	PULLER for crankshaft gear (B 16)		2	X			X	X	
1431	BLEEDING KEY, N = 1/4", for brake system		5	X			X	X	
1442	DRIFT for removing and fitting king pin bushing		6				X	X	
1459	DRIFT for removing valve guide (B 16, B 18)	L	2	X	X	X	X	X	
1460	HOLDER for removing door handle and window winder						X	X	
1791	PULLER for wheel hub and brake drum		46,5 6,7	X		X	X	X	
1794	PULLER for inner bearing, steering knuckle		5,6	X		X	X	X	
1797	DRIFT for fitting outer front wheel bearing		6,7	X		X	X	X	
1798	DRIFT for fitting oil seal in front wheel hub	B L	5,6,7	X		X	X	X	
1799	DRIFT for removing inner front wheel bearing		6,7	X		X	X	X	
1800	DRIFT for removing outer race, outer front wheel bearing		6,7	X		X	X	X	
1801	STANDARD HANDLE, 18 x 200, for drifts with 18 mm diameter hole	B L		X	X	X	X	X	
1805	SLEEVE for fitting drive shaft bearings		46	X		X	X	X	

SVO	DESCRIPTION and use	Alt. product	Part	120-series	140-series	1800	P210	PV544	Notes
1806	CUSHIONING RING for removing and fitting drive shaft bearings		46	X		X	X	X	
1807	SLEEVE for fitting outer ring, drive shaft bearing (ENV)		46	X				X	
1819	PULLER for upper bearing outer ring and steering shaft bushing	B L	6	X		X	X	X	
1845	PRESS TOOL, 3/4"-16 UNF, for fitting drive flange (Spicer rear axle)	L	46	X	X	X	X	X	
1866	DRIFT for removing and fitting gudgeon pin (B 18)	L	2	X	X	X	X	X	
1867	DRIFT for bushing in rocker arm and connecting rod (B 18)	B L	2	X	X	X	X	X	
2010	DRIFT for oil seal on cover for input shaft, gearbox	B L	43	X	X	X	X	X	Used together with SVO 1801
2044	FIXTURE for gearbox when dismantling and assembling	L	43	X	X	X	X	X	Used together with SVO 4109
2049	FLANGING TOOL for brake pipes	B L	5				X	X	
2079	TOOL for removing plunger, oil pressure relief valve (B 16)		2	X			X	X	
2119	UPSETTING TOOL for eccentric pin, early production		5	X					
2164	PULLER for rear pinion bearing (Spicer)	L	46	X		X	X	X	
2176	FITTING RING for piston (B 18)	L	2	X	X	X	X	X	
2197	DRIFT for fitting grease cap, front wheel hub		5,6,7	X		X	X	X	
2199	PROTECTING SLEEVE for oil seal when fitting steering shaft	B	6	X		X	X	X	
2201	SPANNER, N = 34 mm, for eccentric bushing		6				X	X	
2204	EXTRACTOR for drive shaft		46	X		X	X	X	
2205	SLEEVE for fitting drive shaft bearings	L	46	X		X	X	X	
2224	TOOL for removing king pin		6				X	X	
2225	REAMER, 25.36 mm diameter, for steering shaft bushings		6	X		X	X	X	
2227	DRIFT for oil seal, steering shaft		6	X		X	X	X	

SVO	DESCRIPTION and use	Alt. product	Part	120-series	140-series	1800	P210	PV544	Notes
2228	DRIFT for fitting steering shaft bushing		6	X		X	X	X	
2250	PULLER for camshaft gear (B 16, B 18)	L	2	X	X	X	X	X	
2254	GUIDE for reamer SVO 2225 (140-series) and for reamer SVO 2721		6	X	X	X	X	X	
2261	PULLER for round drive flange	L	43 45 46	X	X	X	X	X	
2262	PULLER for drive yokes		43 46	X	X	X	X	X	
2263	PULLER for removing steering wheel		6	X					All 120 models up to 120D (2-door) and 120G (4-door)
2264	SPANNER, N = 17 mm, for final tightening of cylinder head nuts (B 16)		2	X			X	X	
2266	COUNTERHOLD for shaft and impeller, coolant pump (B 16, B 18)	B L	2	X		X	X	X	
2270	DRIFT for fitting seal, coolant pump (B 16)	B L	2	X			X	X	
2271	FIXTURE for ball bearing, coolant pump (B 16)		2	X			X	X	
2278	FITTING RING for piston (B 16)		2	X			X	X	
2279	PULLER for belt pulley on crankshaft (B 16) and for dynamo		2	X	X	X	X	X	
2280	BLEEDING KEY, N = 3/8", for front wheel brakes, early production		5	X					
2281	TOOL for removing lower ball joint, wishbone		6	X		X			
2284	DIAL GAUGE HOLDER for adjusting final drive	L	46	X	X	X	X	X	
2289	DRIFT for fitting valve guide (B 18)	L	2	X	X	X	X	X	
2294	TOOL for removing ball joint		6,7	X	X	X	X	X	
2297	TOOL for removing clips for door handle and window winder handle		8	X					
2300	FIXTURE for upper wishbone		6				X	X	
2301	EXTRACTOR for reverse shaft, M30, M40, M41 gearboxes	L	43	X	X	X	X	X	
2302	DRIFT for thrust washer when fitting countershaft, M30, M40 gearboxes	L	43	X	X	X	X	X	Two used together with SVO 2303

SVO	DESCRIPTION and use	Alt. product	Part	120-series	140-series	1800	P210	PV544	Notes
2303	DRIFT for fitting intermediate gear, M30, M40 gearboxes	L	43	X	X	X	X	X	
2304	PRESS TOOL, 5/8"-18 UNF, for fitting drive flange	L	43 46	X	X	X	X	X	
2321	DRILLING TEMPLATE for drilling holes for flasher and parking light in front mudguard		8				X	X	
2322	FIXTURE for adjusting clutch levers	B L		X		X	X	X	
2324	GAUGE for float level (B 16B)		2	X				X	
2325	PULLER for removing steering wheel		6	X			X	X	Concerns 120-series with effect from 120E (2-door) and 120K (4-door)
2327	FIXTURE for welding side member		8					X	
2328	ASSEMBLING FIXTURE for side member		8					X	
2329	HOLDER for welding tubular member		8					X	
2330	ROLLING TOOL for removing metal strip on side member		8					X	
2331	FIXTURE for welding left-hand side member		8					X	
2337	DRIFT for removing oil seal, rear axle	B L	46		X				
2338	DRILLING BUSH for removing screw in headlamp casing		8				X	X	
2347	DRILLING TEMPLATE for drilling holes in left-hand rear mudguard		8					X	
2348	DRILLING TEMPLATE for drilling holes in right-hand rear mudguard		8					X	
2369	CENTERING TOOL for jet sleeve, carburettor (B 16B)		2	X				X	
2370	PULLER for pitman arm		6	X	X	X	X	X	
2371	ASSEMBLING TRESTLE for front end		8				X	X	
2381	BLEEDING KEY, N = 11.2 mm, for brake system	B L	5	X		X			
2384	KEY, N = 28 mm, for master cylinder filling plug		5				X	X	
2385	FIXTURE for replacing wheel arch and side member		8	X		X			

SVO	DESCRIPTION and use	Alt. product	Part	120-series	140-series	1800	P210	PV544	Notes
2386	TOOL for fitting timing gear casing and crankshaft gear (B 16)		2	X			X	X	
2392	PULLER for rear pinion bearing		46	X	X	X	X	X	
2393	MEASURING TOOL for adjusting pinion (Spicer)		46	X	X	X	X	X	
2394	EXPANDING TOOL for removing and fitting differential (Spicer)		46	X	X	X	X	X	
2395	DRIFT for fitting rear pinion bearing	L	46	X	X	X	X	X	
2396	STAND for carburettor when fitting bushing for throttle shaft (B 16)		2	X			X	X	
2397	REAMER, 8.85 mm diameter, for reaming seat for throttle shaft bushing (Zenith)		2	X			X	X	Used together with SVO 2603
2398	REAMER, 7.01 mm diameter, for reaming throttle shaft bushing (Zenith)		2	X			X	X	
2399	DRIFT for removing and fitting throttle shaft bushing (Zenith)		2	X			X	X	
2400	REAMER, 9.75 mm diameter, for reaming seat for throttle shaft bushing (SU)		2	X		X		X	Used together with SVO 2603
2401	REAMER, 7.91 mm diameter, for reaming throttle shaft bushing (SU)		2	X		X		X	
2402	DRIFT for removing and fitting throttle shaft bushing (SU)		2	X		X		X	
2402	SPANNER for fitting front pinion bearing (Spicer)	L	46	X	X	X	X	X	
2405	PULLER for crankshaft gear (B 18)	L	2	X	X	X	X	X	
2407	PRESS TOOL for fitting crankshaft gear (B 18)	L	2	X	X	X	X	X	
2408	PRESS TOOL, 1"-12 UNF, for fitting camshaft gear (B 18)	L	2	X	X	X	X	X	
2409	SPANNER (counterhold) for drive flange	45	43 45 46	X	X	X	X	X	
2410	DRIFT for fitting oil seal on drive flange (ENV)		46	X				X	
2412	DRIFT for fitting bearing, M30, M40, M41 gearboxes	L	43	X	X	X	X	X	
2413	DRIFT for fitting oil seal in rear cover, M30, M40, M41 gearboxes	L	43	X	X	X	X	X	
2414	CLAMP for fixture SVO 2327, 2329		8					X	

SVO	DESCRIPTION and use	Alt. product	Part	120-series	140-series	1800	P210	PV544	Notes
2415	PRESSURE GAUGE for checking oil pressure, overdrive		43	X	X	X			
2417	DRIFT for bearings in planet gears and output shaft, overdrive	B	43	X	X	X			
2418	EXTRACTOR for oil pump, overdrive		43	X	X	X			
2419	SPANNER for valve seat, oil pump, overdrive		43	X	X	X			
2420	CENTERING TOOL for splines in planet gear carrier and one-way hub, overdrive		43	X	X	X			
2421	PRESS TOOL, 9/16"–18 UNF, for fitting drive flange, overdrive		43	X	X	X			
2422	DRIFT for fitting oil seal, output shaft, overdrive		43	X	X	X			
2423	EXTRACTOR for needle bearing, output shaft, overdrive		43	X	X	X			
2424	GRIPPING TOOL for valve tappets (B 18)	L	2	X	X	X	X	X	
2425	LIFTING TOOL for engine (B 18)		2	X	X	X	X	X	
2426	HEXAGON SPANNER, 10 mm for gearbox bolts (for cars with B 16 engine)		43	X			X	X	
2427	UNIVERSAL JOINT for spanners when removing and installing gearbox	L	43	X	X	X	X	X	Used together with SVO 2426, 2487, 2488
2428	CABLE SPANNER, 10 mm for gearbox bolts (for cars with B 16 engine)		43	X			X	X	
2429	PRESS WASHER for removing impeller, coolant pump (B 18)	B L	2	X	X	X	X	X	
2430	DRIFT for fitting seal, coolant pump (B 18)	L	2	X	X	X	X	X	
2435	GUIDE PIN (two) for cylinder head (B 18)	L	2	X	X	X	X	X	
2437	TOOL for removing and fitting rubber pad on rear gearbox mounting		43				X	X	
2438	CENTERING SLEEVE for timing gear casing and circlip for felt ring (B 18)	L	2	X	X	X	X	X	
2439	CENTERING SLEEVE for rear sealing flange (B 18)	L	2	X	X	X	X	X	
2440	PULLER for hub on crankshaft (B 18)	L	2	X	X	X	X	X	
2456	DRIFT for fitting oil seal, drive shaft		46	X		X	X	X	

SVO	DESCRIPTION and use	Alt. product	Part	120-series	140-series	1800	P210	PV544	Notes
2462	PULLER for hub, coolant pump (B 18)	L	2	X	X	X	X	X	
2463	DRIFT for removing and fitting bearing, coolant pump (B 18)	L	2	X	X	X	X	X	
2468	DRIFT for removing and fitting sleeve in cylinder head (B 16)		2	X			X	X	
2475	DRILLING TEMPLATE for drilling holes in front mudguard						X	X	
2483	PULLER for differential carrier bearings (Spicer 27, 30)		46	X	X	X	X	X	
2484	CENTERING MANDREL for clutch disc		41	X	X	X	X	X	
2486	TOOL for fitting plate nut		8	X					
2487	HEXAGON SPANNER, 3/8", for upper gearbox bolts (cars with B 18 engine)		43	X	X	X	X	X	
2488	HEXAGON SPANNER, 8 mm, for upper gearbox bolts (cars with B 18 engine)		43	X		X	X	X	
2498	DRIFT for bushings in intermediate arm bracket	L	6	X		X	X	X	
2517	REAMER, 8.73 mm diameter, for valve guide	L	2	X	X	X	X	X	
2520	STAND for fixtures SVO 2521, 2522, 2560, 2561	B L		X	X	X	X	X	
2521	FIXTURE for B 18 engine when dismantling and assembling	L		X	X	X	X	X	Used together with SVO 2520
2522	FIXTURE for rear axle when working on final drive		46	X	X	X	X	X	Used together with SVO 2520
2530	FIXTURE for automatic gearbox when dismantling and assembling		44	X	X				
2531	PRESSURE GAUGE WITH CONNECTIONS for checking oil pressure, automatic gearbox		44	X	X				
2532	ATTACHING PLATE for measuring end float, input shaft, automatic gearbox		44	X	X				
2533	PRESS TOOL for clutch when removing and fitting locking ring, automatic gearbox		44	X	X				
2534	RING for fitting piston in rear clutch, automatic gearbox		44	X	X				
2435	SPECIAL SLEEVE, 5/16" square, for adjusting rear band, automatic gearbox		44	X	X				
2537	PACKING BLOCK for adjusting band, automatic gearbox		44	X	X				

SVO	DESCRIPTION and use	Alt. product	Part	120-series	140-series	1800	P210	PV544	Notes
2538	SPANNER, N = 17.5 mm, for lock nut, contact for starting lock and reversing lights, automatic gear-box		44	X	X				
2545	REAMER for reaming king pin bushing		6				X	X	
2546	FIXTURE for king reamer SVO 2545		6				X	X	
2547	FIXTURE for replacing wheel arch, late production		8	X					Used together with SVO 2385
2548	SPANNER for adjusting rear wheel brakes		5	X		X			
2549	SPANNER, N = 19 mm, for nut pull device for choke control		8	X			X	X	PV554 chassis No. 295599-330099, 120 chassis No. 54400-84299
2560	FIXTURE for front axle member		6	X	X	X	X	X	Used together with SVO 2520
2561	FIXTURE for B 16 engine when dismantling and assembling		2	X			X	X	Used together with SVO 2520
2566	FIXTURE when replacing wheel arch, cars with BW-35		8	X					Used together with SVO 2385
2567	PULLER for differential carrier bearings (Spicer 23)	B L	46	X		X	X	X	
2572	PRISING TOOL for removing and fitting torsion rod for luggage door		8	X					
2595	ADJUSTING RINGS for differential (Spicer 27, 30)		46	X	X	X	X	X	
2596	RIVETING TONGS for upholstery eyelets in front seat, early production		8	X					
2597	BRAKE for crown wheel when checking tooth contact		46	X	X	X	X	X	
2598	DRIFT for removing outer ring, rear pinion bearing (Spicer 27, 30)		46	X	X	X	X	X	
2599	DRIFT for removing outer ring, front pinion bearing (Spicer 27, 30)		46	X	X	X	X	X	
2600	MEASURING FIXTURE for adjusting rings SVO 2595, 2685		46	X	X	X	X	X	
2601	HOLDER for expanding tool SVO 2394		46	X	X	X	X	X	
2603	STAND for reconditioning carburettor (Zenith and SU) (B 18)		2	X		X	X	X	
2611	HOLDER for dial gauge when checking end float, drive shafts		46	X		X	X	X	
2612	PLATE for checking end float, drive shafts		46	X		X	X	X	

SVO	DESCRIPTION and use	Alt. product	Part	120-series	140-series	1800	P210	PV544	Notes
2684	SPANNER for adjusting rings	L	46	X	X	X	X	X	Used together with SVO 2685, 2689
2685	ADJUSTING RING for pinion (Spicer 27, 30)		46	X	X	X	X	X	
2686	PRESS TOOL for fitting outer rings, pinion bearings (Spicer 27, 30)		46	X	X	X	X	X	
2687	ADJUSTING RING for differential (Spicer 23)		46	X		X	X	X	
2688	PRESS TOOL for fitting outer rings, pinion bearings (Spicer 23)	L	46	X		X	X	X	
2689	ADJUSTING RING for pinion (Spicer 23)	L	46	X		X	X	X	
2690	DRIFT for removing outer ring, rear pinion bearing (Spicer 23)	L	46	X		X	X	X	
2699	PRESS TOOL for ball joints and rubber bushings, wishbones		6	X	X	X			Used together with SVO 2700-2706
2700	SLEEVE for removing ball joint, lower wishbone		6		X				Used together with SVO 2699
2701	SLEEVE for removing and fitting ball joint, upper wishbone; fitting ball joint, lower wishbone; removing and fitting rubber bushing, lower wishbone		6	X	X	X			Used together with SVO 2699, 2703, 2704
2702	SLEEVE for removing and fitting rubber bushing, upper wishbone		6		X				Used together with SVO 2699, 2706
2703	DRIFT for fitting ball stud, lower wishbone		6		X				Used together with SVO 2699, 2701
2704	DRIFT for fitting ball stud, upper wishbone		6		X				Used together with SVO 2699, 2701
2705	DRIFT for removing and fitting rubber bushing, lower wishbone		6	X	X	X			Used together with SVO 2699, 2701
2706	DRIFT for removing and fitting rubber bushing, upper wishbone		6		X				Used together with SVO 2699, 2702
2707	CUSHIONING RING for fitting bearing and stop ring, drive shaft		46		X				
2708	SPANNER for adjusting end float, drive shafts		46		X				
2709	EXTRACTOR for drive shaft		46		X				
2710	PULLER for drive shaft bearing		46		X				
2711	PULLER for removing steering wheel		6		X				
2712	DRIFT for fitting inner oil seal, drive shaft		46		X				

SVO	DESCRIPTION and use	Alt. product	Part	120-series	140-series	1800	P210	PV544	Notes
2713	SOCKET SPANNER, 5/8", for bolt, upper wishbone shaft, adjustment of wheel alignment		6		X				
2714	FIXTURE for removing and installing rear axle		46	X	X	X	X	X	
2715	DRIFT for removing and fitting grease cap on hub		6,7		X				
2716	DRIFT for fitting bushing, steering shaft		6		X				Used together with SVO 1801
2717	DRIFT for fitting upper bearing race, steering cam		6		X				Used together with SVO 1801
2718	DRIFT for removing upper bearing race, steering cam		6		X				Used together with SVO 1801
2719	SLEEVE for fitting oil seal, steering shaft		6		X				
2720	TOOL for removing bushing, steering shaft		6		X				
2721	REAMER for bushing, steering shaft		6		X				Used together with SVO 2254
2722	PULLER for inner ring, inner front wheel bearing		6,7		X				
2723	DRIFT for fitting outer ring, inner front wheel bearing and oil seal in hub		6,7		X				Used together with SVO 1801
2724	DRIFT for fitting outer ring, outer front wheel bearing or removing outer ring, inner front wheel bearing		6,7		X				
2725	DRIFT for removing outer ring, outer front wheel bearing		6,7		X				Used together with SVO 1801
2726	PULLER for front wheel hub		6,7		X				
2727	LIFTING TOOL for engine when removing sump and gear-box		2,46		X				
2728	EXTRACTOR for inner oil seal, drive shaft		46	X	X	X	X	X	
2729	WASHER for removing shaft, upper wishbone		6		X				
2730	DRIFT for removing and fitting bushing, track rod		7		X				Used together with SVO 2733
2731	DRIFT for removing and fitting bushing, support rod		7		X				Used together with SVO 2733
2732	DRIFT for removing and fitting front bushing, support arm		7		X				
2733	CUSHIONING SLEEVE for removing and fitting bushing, support rod and track rod		7		X				

SVO	DESCRIPTION and use	Alt. product	Part	120-series	140-series	1800	P210	PV544	Notes
2734 ¹	DRIFT for removing bushing, relay arm		6		X				Used together with SVO 2699, 2736
2735	DRIFT for fitting bushing, relay arm		6		X				Used together with SVO 2699, 2736
2736	CUSHIONING PLATE for removing bushing, relay arm		6		X				Used together with SVO 2699, 2734
2737	HOLDER for dial gauge when checking end float, drive shaft		46		X				
2738	SPANNER for tank fitting		9		X				
2739	HOLDING CLAMP for gas spring, luggage door		8		X				
2740	KEY for bleeding brake system		5		X				
2741	BRAKE PRESSURE GAUGE for testing brake system		5	X	X	X			
2742	HOLDER for cable spring, handbrake		5		X				
2743	GUIDE PINS for installing M30, M40, M41 gearboxes		43	X	X	X	X	X	
2744	PRESS TOOL for gas spring, luggage door		8		X				
2746	FIXTURE for removing and installing automatic gearbox		44	X			X	X	
2748	TORQUE WRENCH for adjusting front band		44	X	X				
2763	SPINDLE for SVO 1791 (intended for nut tightener) when removing rear brake drum		45 46	X		X	X	X	
2764	PRESS TOOL for removing and fitting spring bushing	L	7				X		
2777	WELDING FIXTURE for replacing and checking side member		8		X				
2779	SPANNER, N = 11 mm, for bolt in drive flange, propeller shaft		43 45 46	X	X	X	X	X	
2806	DRIFT for fitting oil seal on drive flange (Spicer rear axle)		46	X	X	X	X	X	
2809	PRESS TOOL for pressing in and checking plunger in brake yoke		5		X				
4005	CENTERING TOOL for king pin		6				X	X	
4025	DRIFT for fitting relay arm bushing	B	6				X	X	

SVO	DESCRIPTION and use	Alt. product	Part	120-series	140-series	1800	P210	PV544	Notes
4028	DRIFT for fitting 3rd speed gear wheel, mainshaft (M4)		43	X				X	
4030	EXTRACTOR for oil seal on drive flange, etc.		43 46,6	X	X	X	X	X	
4034	DRIFT for fitting drive flange, propeller shaft	B	45				X	X	
4042	PULLER for differential carrier bearings (ENV)		46	X				X	
4047	PRESS TOOL for outer rings of pinion bearings (ENV)		46	X				X	
4049	PRESS TOOL, M18 x 1.5, for fitting drive flange		46	X				X	
4059	KEY for adjusting nut (ENV)		46	X				X	
4063	DRIFT for removing front pinion bearing outer ring (ENV)		46	X				X	
4064	DRIFT for removing rear pinion bearing (ENV) and for front pinion bearing (Spicer 23)	L	46	X		X	X	X	
4074	SPRING CLIP for wheel cylinder		5	X		X	X	X	
4078	EXTRACTOR for oil seal on drive shaft or for bearing in jacket tube (PV544, P210)		46,6	X			X	X	
4080	DRIFT for pressing in support bearing, propeller shaft		45			X	X	X	
4081	CUSHIONING RING for fitting support bearing in retainer, propeller shaft (early production support bearing)		45	X	X	X	X	X	
4084	CRAMP for fitting pedals		41				X	X	
4088	DRIFT for fitting pedal bushing		41				X	X	
4089	CUSHIONING RING for pressing pedal bushing or relay arm bushing in and out		41,6				X	X	
4090	PULLER for ball bearing, flywheel (B 16, B 18) or for needle bearing, relay arm bracket (120, 1800)	L	2,41	X	X	X	X	X	
4109	STAND for gearbox and rear axle when dismantling and assembling	L	43 46	X	X	X	X	X	Used together with SVO 2044
4110	FIXTURE for final drive (ENV)		46	X				X	Used together with SVO 4109
4112	DRIFT for fitting differential carrier bearings	L	46	X	X	X	X	X	
4113	DRIFT for fitting upper bearing steering box	B L	6				X	X	

ILLUSTRATED LISTS

120-series
1800

140-series

P210

B 18 ENGINE

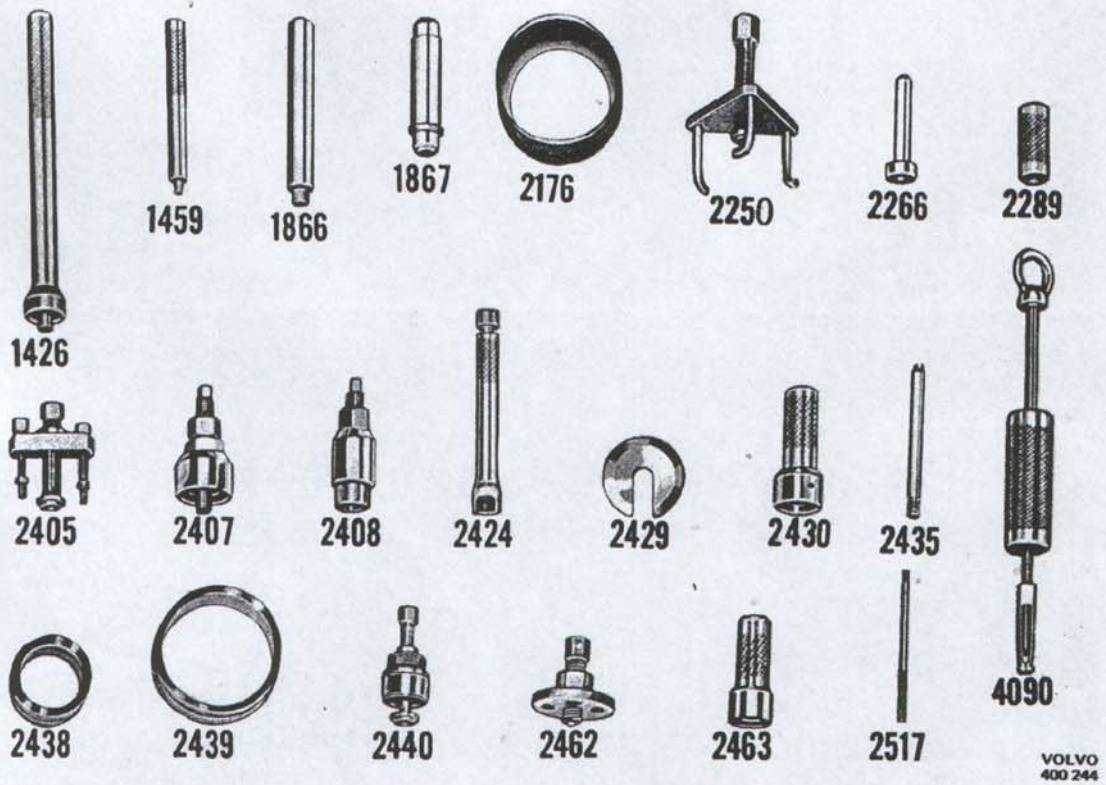

SVO
No.
1426 Drift for fitting support bearing.
1459 Drift for fitting valve guide.
1866 Drift for removing and fitting gudgeon pin.
1867 Drift for removing and fitting bushing in rocker arm and connecting rod.
2176 Fitting ring for piston (standard diameter).
2250 Puller for camshaft gear.
2266 Drift for removing and fitting hub and impeller, water pump.
2289 Drift for fitting valve guide.
2405 Puller for crankshaft gear.
2407 Press tool for fitting crankshaft gear.
2408 Press tool for fitting camshaft gear.
2424 Grip tool for removing and fitting valve tappet.

SVO
No.
2429 Press washer for removing impeller, water pump.
2430 Drift for fitting seal, water pump.
2435 Guide pins for fitting cylinder head (two).
2438 Centering sleeve for timing gear casing and for fitting circlip for felt ring.
2439 Centering sleeve for rear sealing flange and for fitting circlip for felt ring.
2440 Puller for hub on crankshaft.
2462 Puller for hub, water pump.
2463 Drift for removing and fitting bearing, water pump.
2517 Reamer for valve guide.
4090 Extractor for pilot bearing, flywheel.

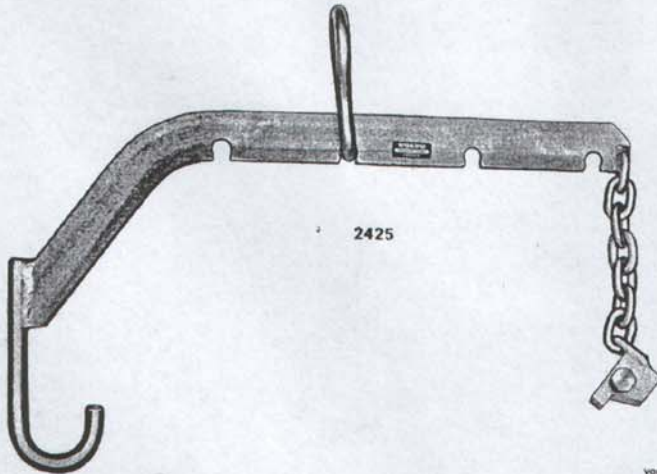

SVO 2425 Lifting tool for B 18 engine when replacing. (SVO 4118, not illustrated, is used for B 16 engine).

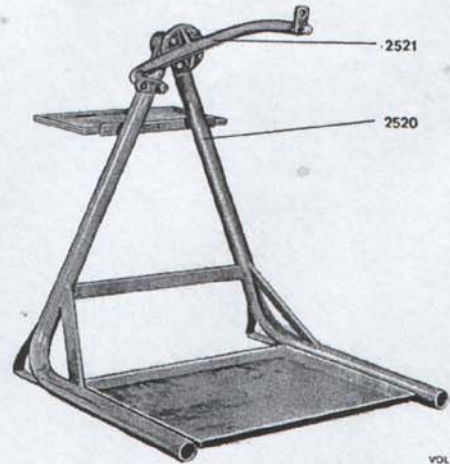

SVO 2520 Stand with engine fixture SVO 2521. Used for engine reconditioning (engine fixture SVO 2561 is used for B 16 engine).

POWER TRANSMISSION, REAR AXLE

Clutch

Clutch fixture SVO 2322 with accessories.

- A. Handle
- B. Arm
- C. Push rod
- D. Bottom plate
- E. Packing block No. 3 (four)
- F. Packing block No. 2 (four)
- G. Packing block No. 1 (three)
- H. Packing block No. 0 (three)
- I. Measuring gauge with holder
- J. 3-point support (three)

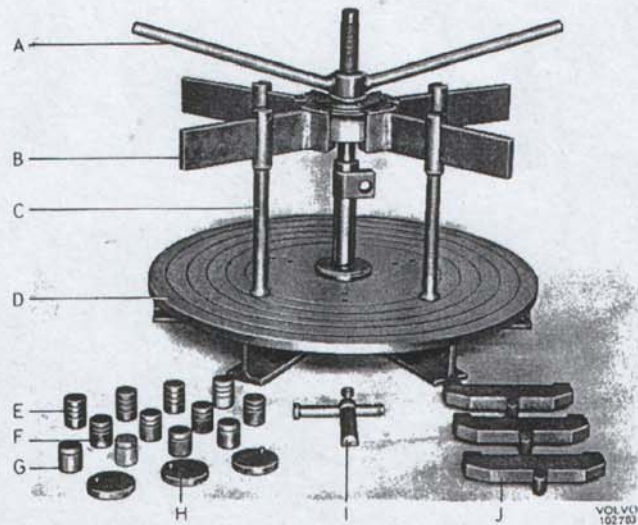

- SVO
No.
1426 Drift for pilot bearing in flywheel.
2484 Mandrel for centering clutch disc.
4090 Extractor for ball bearing in flywheel.

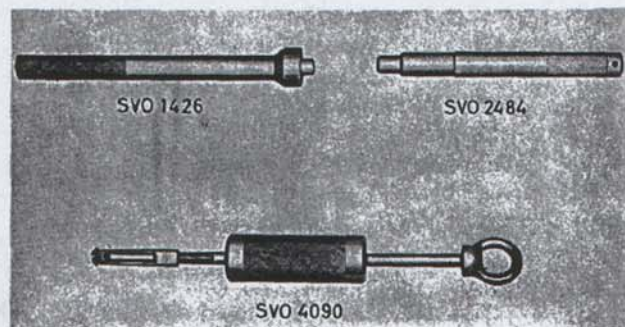

Gearbox

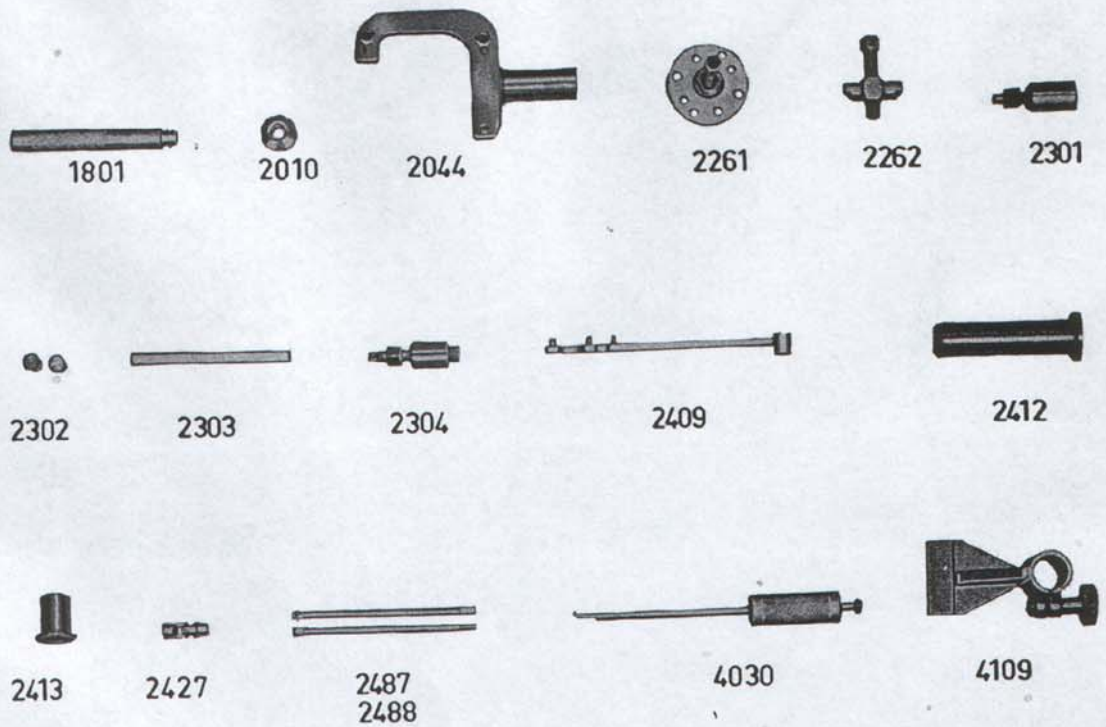

- SVO
No.
- 1801 Standard handle, 18 x 200 mm.
 - 2010 Drift for fitting oil seal in cover for input shaft.
 - 2044 Fixture for gearbox when dismantling and assembling. (Used together with SVO 4109).
 - 2261 Puller for round drive flange.
 - 2262 Puller for drive yokes.
 - 2301 Extractor for removing reverse shaft.
 - 2302 Drift for thrust washer. Two are used together with SVO 2303 when fitting intermediate gear.
 - 2303 Drift for fitting intermediate gear.
 - 2304 Press tool for fitting drive flange.
 - 2409 Counterhold for drive flange.

- SVO
No.
- 2412 Drift for fitting bearing on input shaft, for bearing in rear cover for output shaft, and for fitting input shaft in housing.
 - 2413 Drift for fitting oil seal in rear cover.
 - 2427 Universal joint for spanners SVO 2487 and SVO 2488.
 - 2487 Hexagon spanner, 3/8", for upper gearbox bolts.
 - 2488 Hexagon spanner, 8 mm, for upper gearbox bolts.
 - 4030 Extractor for oil seal on drive flange.
 - 4109 Stand for fixture SVO 2044.

Y01402

Overdrive unit

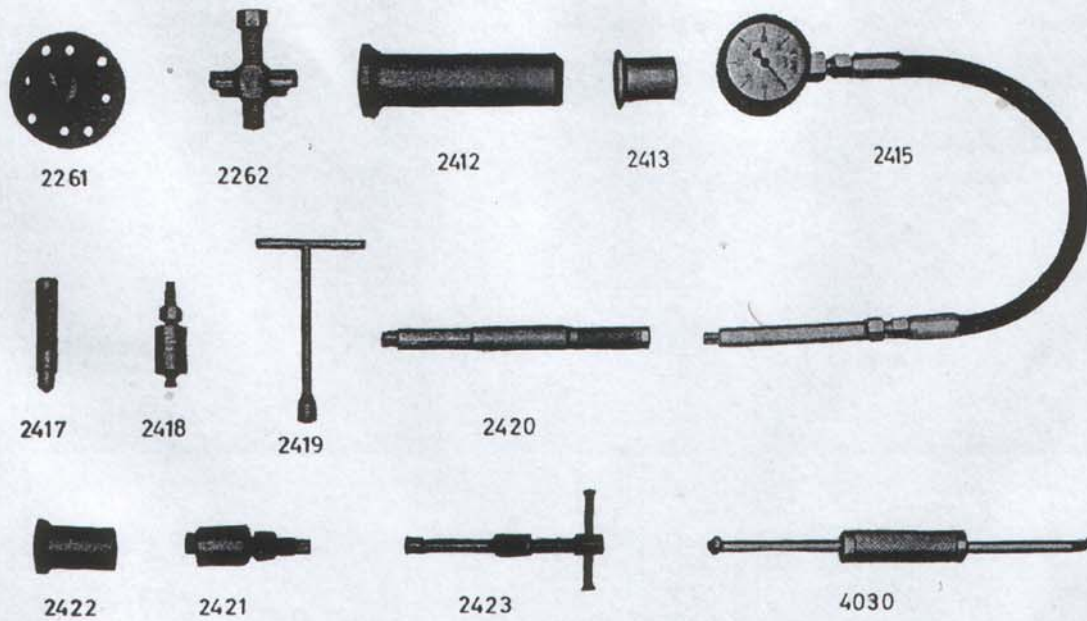

VOLVO
100 815

SVO

No.

- 2261 Puller for round drive flange.
- 2262 Puller for drive yokes.
- 2412 Drift for fitting front bearing on output shaft.
- 2413 Drift for fitting rear bearing on output shaft.
- 2415 Pressure gauge for checking oil pressure.
- 2417 Drift for removing needle bearing in planet gear and for fitting bearing in planet gear and output shaft.
- 2418 Extractor for oil pump, overdrive.

SVO

No.

- 2419 Spanner for valve seat, oil pump.
- 2420 Centering tool for splines in planet gear carrier and one-way hub.
- 2421 Press tool for fitting drive flange.
- 2422 Drift for fitting oil seal, output shaft.
- 2423 Extractor for needle bearing in output shaft.
- 4030 Extractor for oil seal, output shaft

Automatic gearbox,
120-series

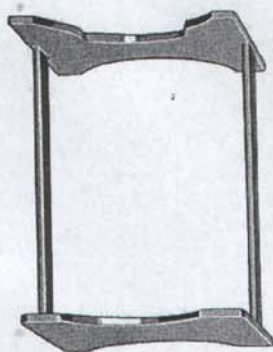

2530



2531



2532



2533



2534



2535



2537



2538



2748

VOLVO
102 932

- SVO
No.
- 2530 Fixture for dismantling and assembling gearbox.
 - 2531 Pressure gauge complete with hose and connection for checking oil pressure.
 - 2532 Attaching plate for magnetic stand when measuring end float, input shaft.
 - 2533 Press tool for compressing clutch when removing and fitting locking ring.
 - 2534 Fitting ring for piston in rear clutch.

- SVO
No.
- 2535 Special 5/16" square sleeve for adjusting rear band.
 - 2537 Packing block for adjusting front band.
 - 2538 Spanner for lock nut, contact for starting lock and reversing light.
 - 2746 Fixture for gearbox when removing and fitting (not illustrated).
 - 2748 Torque wrench for adjusting front brake band.

Propeller shaft

- SVO 4081 Ring for fitting support bearing in retainer (early production support bearing).
SVO 2779 Spanner for propeller shaft with driving flange (not illustrated).



Rear axle, ENV

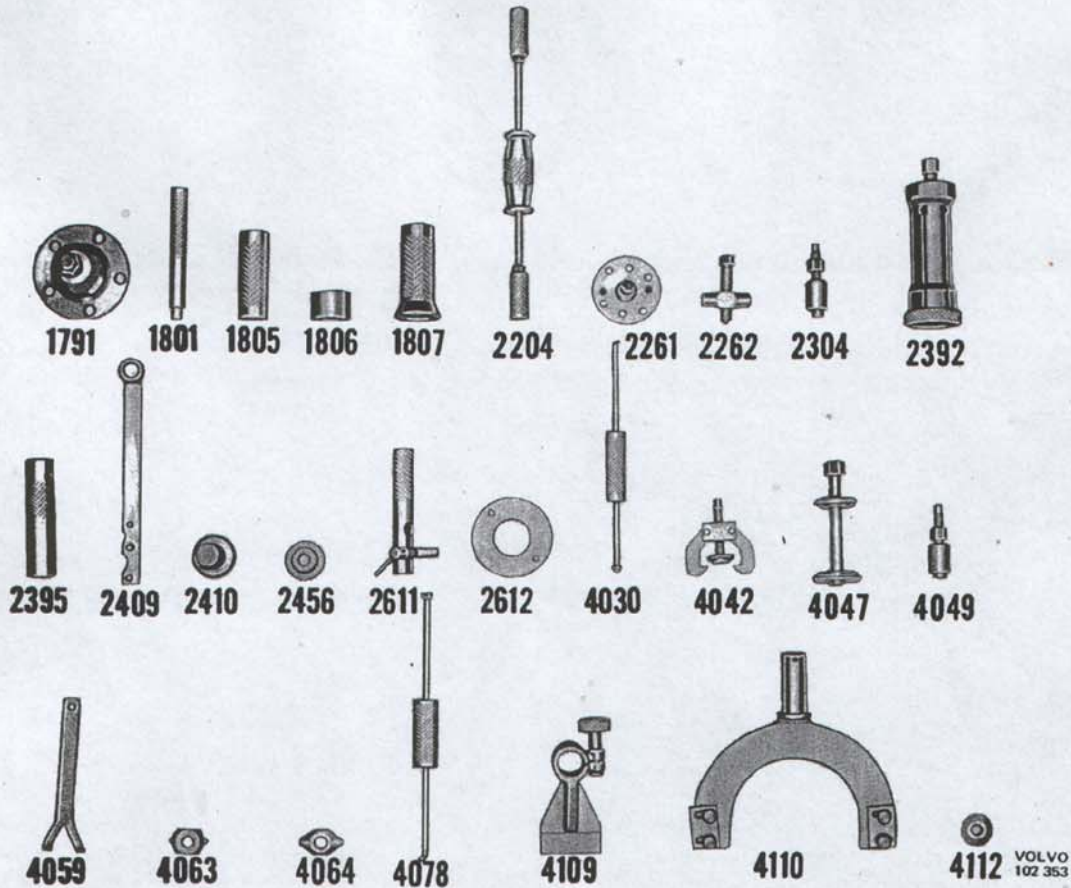

- SVO
No.
1791 Puller for wheel hub.
1801 Standard handle, 18 x 200 mm.
1805 Drift for fitting drive shaft bearing.
1806 Cushioning ring for removing and fitting drive shaft bearing.
1807 Fitting sleeve for drive shaft bearing outer ring.
2204 Extractor for drive shaft.
2261 Puller for round drive flange.
2262 Puller for drive yokes.
2304 Press tool for drive flange (for pinion with 5/8" - 18 thread).
2392 Puller for rear pinion bearing.
2395 Fitting sleeve for rear pinion bearing.
2409 Tool for fitting pinion, and counterhold for drive flange.
2410 Drift for fitting oil seal on drive flange.
2456 Drift for fitting oil seal for drive shaft.

- SVO
No.
2611 Holder for dial gauge.
2612 Plate.
4030 Extractor for oil seal on drive flange.
4042 Puller for differential carrier bearings.
4047 Tool for fitting outer rings of pinion bearings.
4049 Press tool for fitting drive flange (for pinion with 18 x 1.5 mm thread).
4059 Key for adjusting nut.
4063 Tool for removing front pinion bearing outer ring.
4064 Drift for removing rear pinion bearing outer ring.
4078 Extractor for oil seal on drive shaft.
4109 Stand for fixture SVO 4110.
4110 Fixture for final drive.
4112 Drift for fitting differential carrier bearings.

Rear axle

SPICER

The following tools are used for repairs and adjustments to the final drive. For removing and fitting brake drums and drive shafts, a number of additional tools are required which are listed under the heading "Drive shaft".

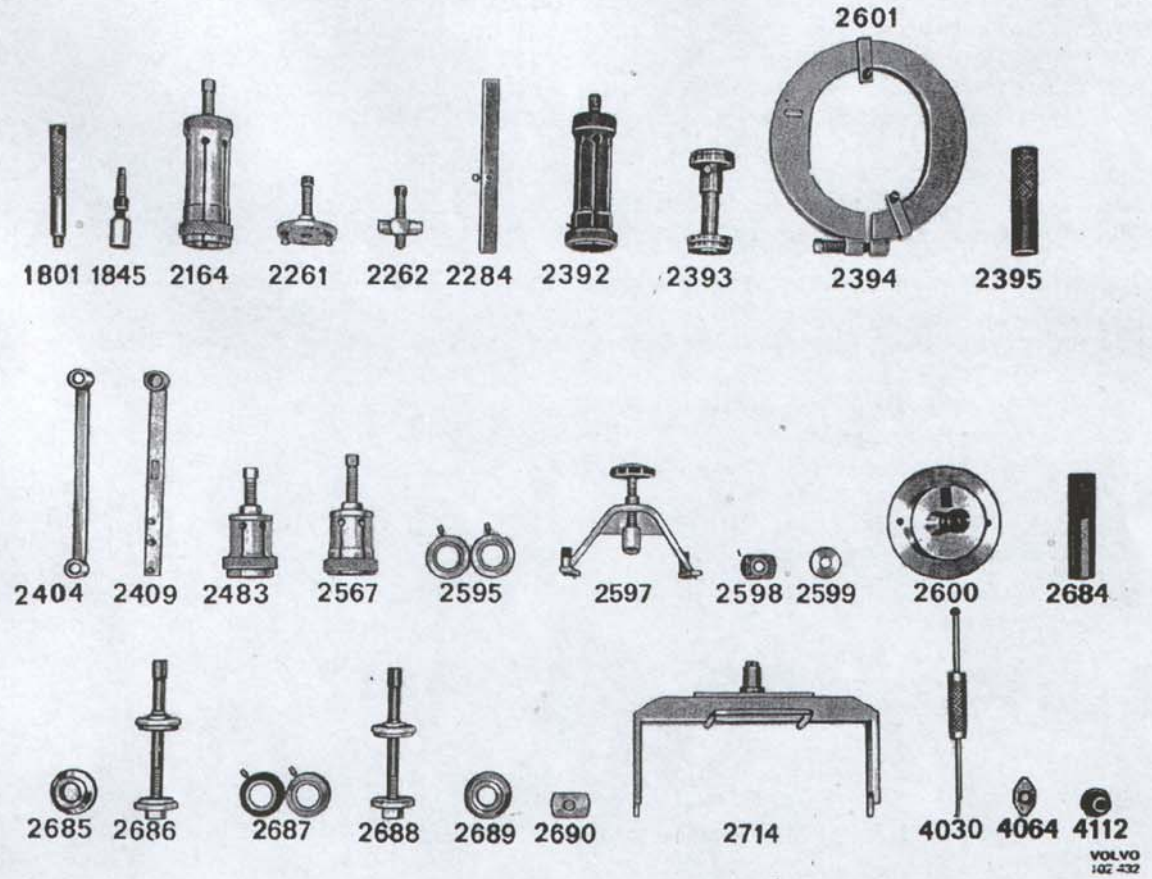

SVO No.		Used on	
		23	27,30
1801	Standard handle, 18 x 200 mm	X	X
1845	Press tool for fitting drive flange	X	X
2164	Puller for rear pinion bearing	X	
2261	Puller for round drive flange	X	X
2262	Puller for drive yokes	X	X
2284	Holder for dial gauge when adjusting final drive	X	X
2392	Puller for rear pinion bearing		X
2393	Measuring tool for adjusting pinion	X	X
2394	Expanding tool used when removing and fitting differential	X	X
2395	Fitting sleeve for inner ring, rear pinion bearing	X	X

SVO No.		Used on	
		23	27,30
2404	Spanner for fitting front pinion bearing	X	X
2409	Counterhold for drive flange	X	X
2483	Puller for differential carrier bearings		X
2520	Stand	X	X
2522	Fixture for rear axle (used together with stand SVO 2520 when working on final drive)	X	X
2567	Puller for differential carrier bearing	X	
2595	Adjusting rings for differential		X
2597	Brake for crown wheel. Used when checking tooth contact	X	X
2598	Drift for removing outer ring, rear pinion bearing		X
2599	Drift for removing outer ring, front pinion bearing		X
2600	Measuring fixture for adjusting rings	X	X
2601	Holder for expanding tool SVO 2394 (fitted on tool)	X	X
2684	Socket spanner for adjusting rings SVO 2685 and SVO 2689	X	X
2685	Adjusting ring for pinion		X
2686	Press tool for fitting outer rings of pinion bearings		X
2687	Adjusting rings for differential	X	
2688	Press tool for fitting outer rings of pinion bearings	X	
2689	Adjusting ring for pinion	X	
2690	Drift for removing outer ring, rear pinion bearing	X	
2714	Fixture for rear axle. Used on garage jack when removing and fitting rear axle	X	X
2806	Drift for fitting oil seal on drive flange (see Fig., page 40)	X	X
4030	Extractor for oil seal on drive flange	X	X
4064	Drift for removing outer ring, front pinion bearing	X	
4112	Drift for fitting differential carrier bearings	X	X

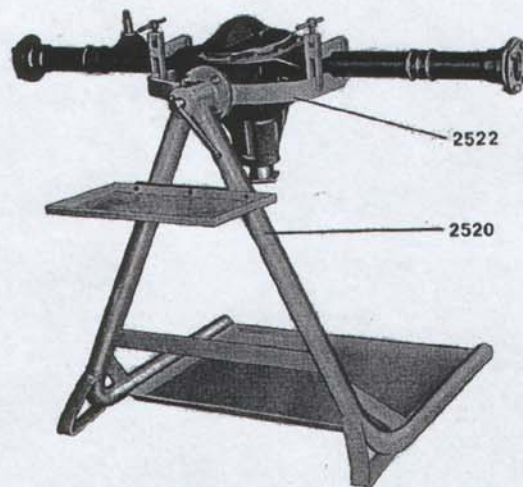

VOLVO
400 049

SVO 2520 Stand with fixture SVO 2522. Used when working on the final drive.

Drive shaft



1791



1801



1805



1806



2204



2205



2456



2611



2612



2728

SVO
No.

- 1791 Puller for wheel hub.
- 1801 Standard handle 18x200 mm.
- 1805 Fitting sleeve for drive shaft bearing.
- 1806 Cushioning ring for removing drive shaft bearing.
- 2204 Extractor for drive shaft.
- 2205 Sleeve for fitting outer ring of bearing.

SVO
No.

- 2456 Drift for fitting oil seal.
- 2611 Holder for dial gauge.
- 2612 Plate.
- 2728 Extractor for inner oil seal.
- 2763 Spindle for supplementing puller SVO 1791 so that the nut tightener can be used. (Shown fitted in SVO 1791 above.)

VOLVO
400 245

BRAKES

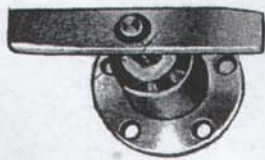

1791



1794



1798



1801



2197



2381



2548

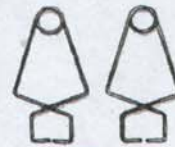

4074

VOLVO
100 592

SVO

No.

- 1791 Puller for hub.
- 1794 Puller for inner ring, front wheel.
- 1798 Drift for fitting oil seal in hub.
- 1801 Standard handle, 18x200 mm.
- 2197 Drift for fitting and removing grease cap.

SVO

No.

- 2381 Bleeding key.
- 2548 Spanner for adjusting rear wheel brakes.
- 2763 Spindle for supplementing SVO 1791 so that the nut tightener can be used, see Fig., page 27.
- 4074 Spring clip for wheel cylinder.

FRONT END AND STEERING GEAR

Front axle



VOLVO
400 243

SVO
No.

- 1791 Puller for wheel hub.
- 1794 Puller for inner ring, inner wheel bearing.
- 1797 Drift for fitting outer wheel bearing.
- 1798 Drift for fitting inner wheel bearing and oil seal in hub.
- 1799 Drift for removing outer race, inner wheel bearing.
- 1800 Drift for removing outer race, outer wheel bearing.

SVO
No.

- 1801 Standard handle, 18x200 mm.
- 2197 Drift for fitting and removing grease cap.
- 2281 Tool for removing lower ball joint, wishbone.
- 2370 Puller for pitman arm.
- 2699 Press tool for removing and fitting rubber bushing 636 675. Used together with SVO 2701 and 2705, see Fig., page 43.

Steering gear

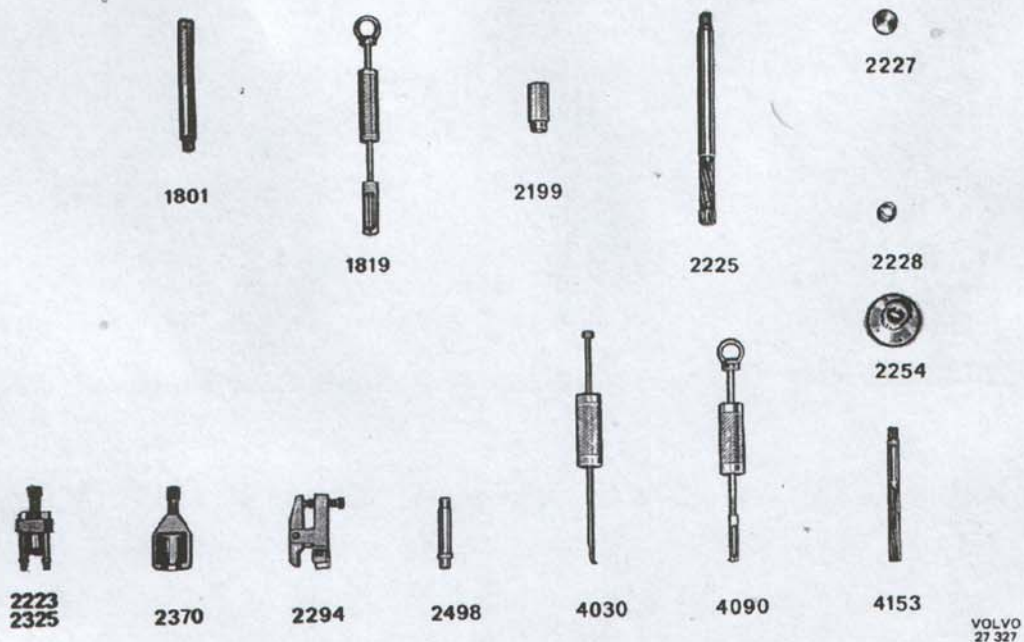

SVO

- No.
- 1801 Standard handle.
 - 1819 Extractor for steering shaft bushings.
 - 2199 Protecting sleeve for oil seal when fitting steering shaft.
 - 2225 Reamer for steering shaft bushings.
 - 2227 Drift for fitting steering shaft oil seal.
 - 2228 Drift for fitting steering shaft bushing.
 - 2254 Guide for reamer SVO 2225.
 - 2263 Puller for steering wheel, all P 120 up to P 120 D (2-door), P 120 G (4-door) and P 120 Station Wagon.¹⁾
 - 2294 Puller for ball joint, tie rod and steering rod.

SVO

- No.
- 2325 Puller for steering wheel with effect from P 120 E (2-door) and P 120 K (4-door).¹⁾
 - 2370 Puller for pitman arm.
 - 2498 Drift for fitting and removing bushings in relay arm bracket.
 - 4030 Extractor for stuffing boxes.
 - 4090 Extractor for needle bearing in relay arm bracket.
 - 4153 Reamer for bushings in relay arm bracket.

¹⁾ On certain late production cars SVO 2263 must be used.

SUSPENSION, WHEELS

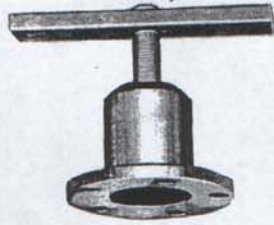

1791



1794



1797



1798



1799



1800



2197



1801

VOLVO
100 664

SVO

No.

- 1791 Puller for wheel hub.
- 1794 Puller for inner ring, inner wheel bearing.
- 1797 Drift for fitting outer bearing ring.
- 1798 Drift for fitting inner bearing ring and oil seal in hub.

SVO

No.

- 1799 Drift for removing inner bearing ring.
- 1800 Drift for removing outer bearing ring.
- 1801 Standard handle, 18x200 mm.
- 2197 Drift for fitting and removing grease cap.
- 2763 Spindle for supplementing SVO 1791 so that the nut tightener can be used, see Fig., page 27.

BODY 120-series



2486



2297



2572

VOLVO
101 244

SVO 2297 Tool for removing clips for door and window winder handles, and for removing and fitting retaining springs for waist moulding.

SVO 2486 Tool for fitting plate nut.
SVO 2572 Tool for removing and fitting torsion rod for luggage door.

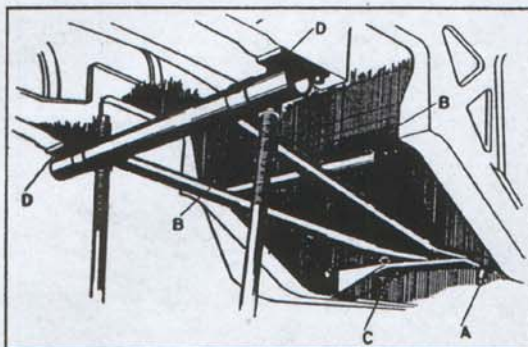

VOLVO
27370

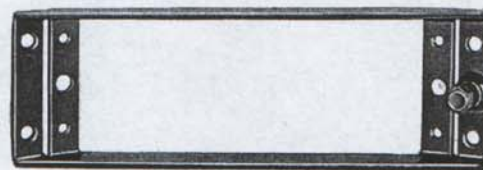

2547

VOLVO
2547

SVO 2385 Fixture for replacing wheel arch and side member.
A. Guide screw
B. Guide screws
C. Fixed dowel
D. Guide pins

SVO 2547 Fixture for replacing wheel arch, late production. Used together with SVO 2385.

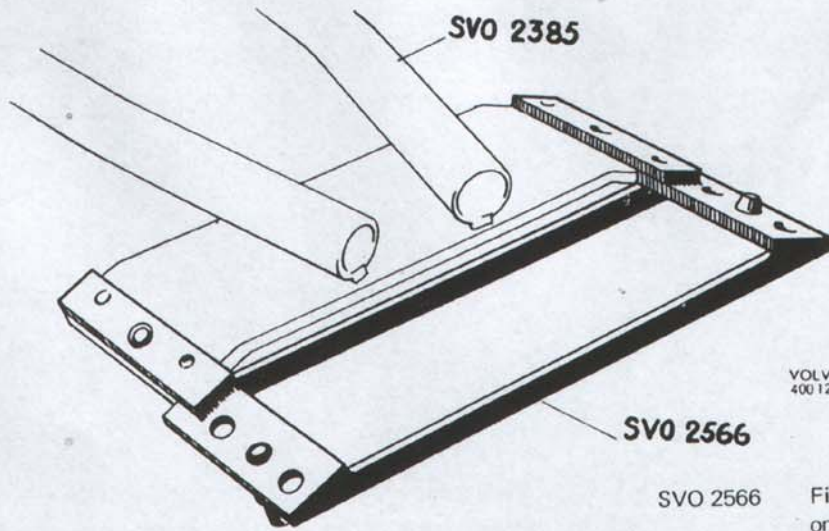

VOLVO
400 125

SVO 2566

SVO 2566

Fixture for replacing wheel arch
on cars with automatic gearbox.
Used together with SVO 2385.

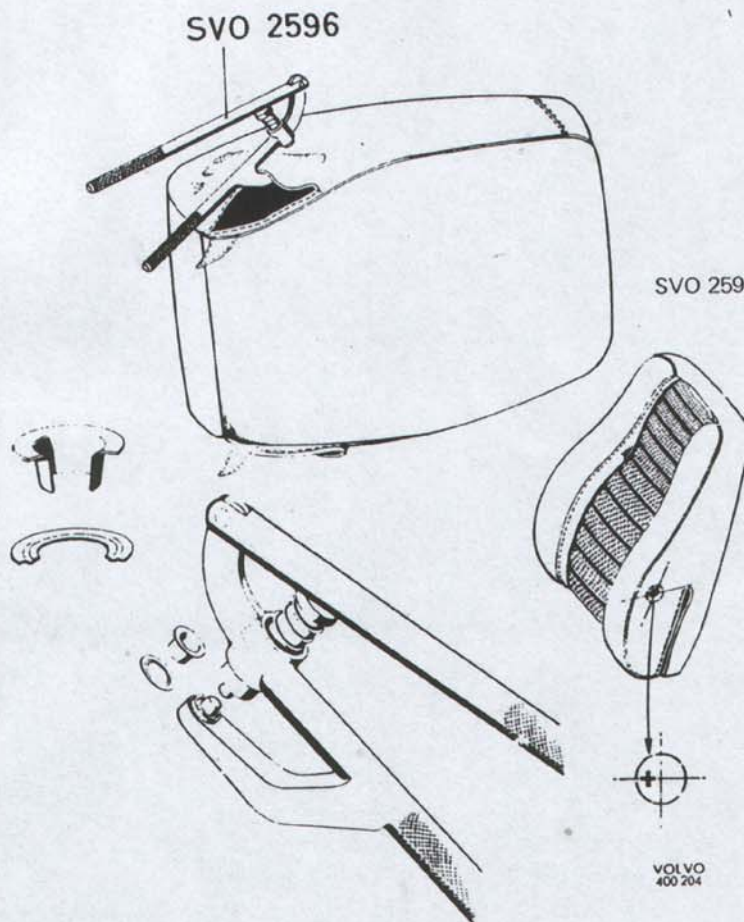

SVO 2596

SVO 2596

Riveting tongs for eyelets in seat
backrest.

VOLVO
400 204

B 18 ENGINE

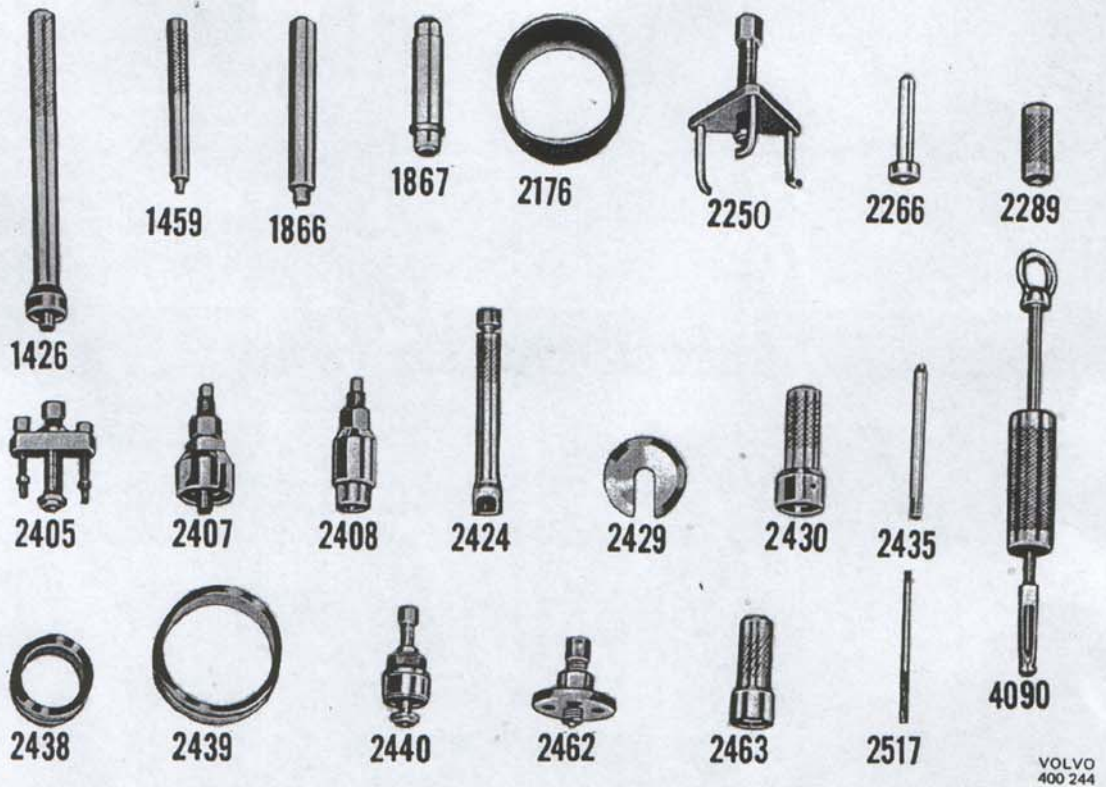

SVO
No.

- 1426 Drift for fitting support bearing.
 1459 Drift for fitting valve guide.
 1866 Drift for removing and fitting gudgeon pin.
 1867 Drift for removing and fitting bushing in rocker arm and connecting rod.
 2176 Fitting ring for piston (standard diameter).
 2250 Puller for camshaft gear.
 2266 Drift for removing and fitting hub and impeller, water pump.
 2289 Drift for fitting valve guide.
 2405 Puller for crankshaft gear.
 2407 Press tool for fitting crankshaft gear.
 2408 Press tool for fitting camshaft gear.
 2424 Grip tool for removing and fitting valve tappet.

SVO
No.

- 2429 Press washer for removing impeller, water pump.
 2430 Drift for fitting seal, water pump.
 2435 Guide pins for fitting cylinder head (two).
 2438 Centering sleeve for timing gear casing and for fitting circlip for felt ring.
 2439 Centering sleeve for rear sealing flange and for fitting circlip for felt ring.
 2440 Puller for hub on crankshaft.
 2462 Puller for hub, water pump.
 2463 Drift for removing and fitting bearing, water pump.
 2517 Reamer for valve guide.
 4090 Extractor for pilot bearing, flywheel.

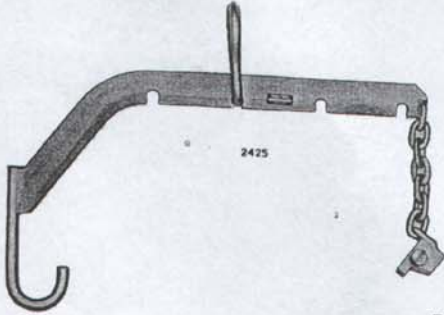

SVO 2425 Lifting tool for engine when replacing.

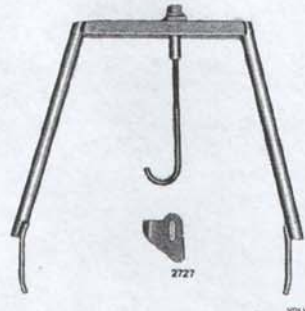

SVO 2727 Lifting tool for engine when removing sump and gearbox.



SVO 2920 Stand with engine fixture SVO 2521. Used when reconditioning engine.

ELECTRICAL SYSTEM

SVO 2738

Spanner for tank fitting.



2738

VOLVO
400 241

POWER TRANSMISSION, REAR AXLE

Clutch

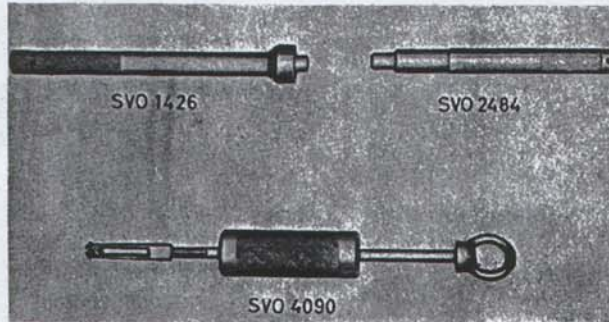

SVO

No.

1426 Drift for pilot bearing in flywheel.

2484 Centering mandrel for clutch disc.

4090 Extractor for ball bearing in flywheel.

VOLVO
27912

Gearbox

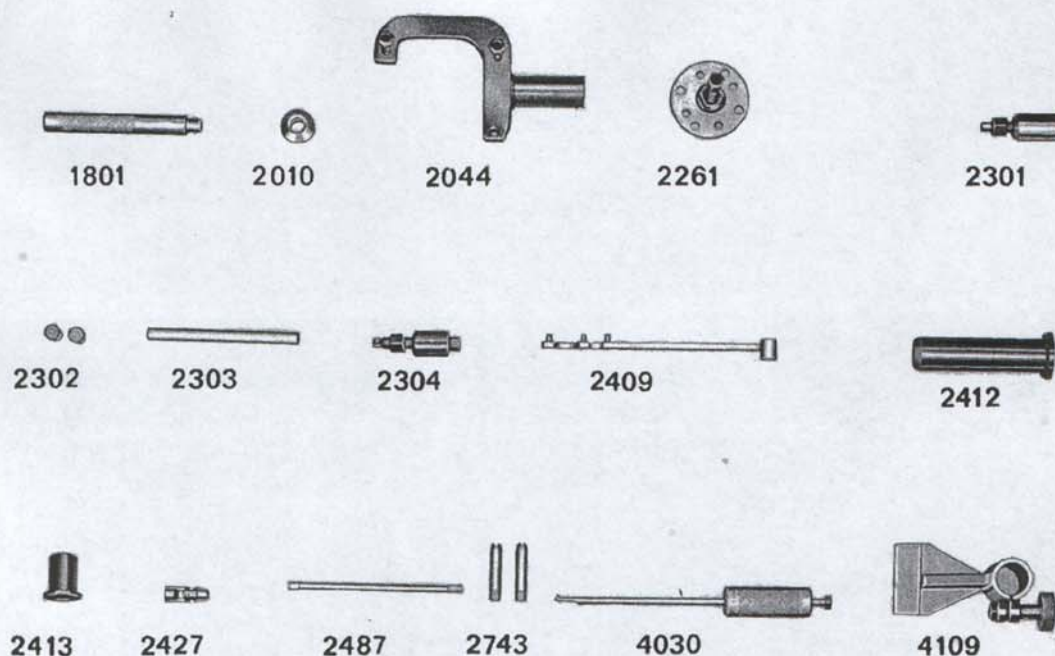
VOLVO
102 061

SVO

- No.
 1801 Standard handle, 18x200 mm.
 2010 Drift for fitting oil seal in cover for input shaft.
 2044 Fixture for gearbox when dismantling and assembling. (Used together with SVO 4109.)
 2261 Puller for drive flange.
 2301 Extractor for removing reverse shaft.
 2302 Drift for thrust washer. Two are used together with SVO 2303 when fitting intermediate gear.
 2303 Drift for fitting intermediate gear.
 2304 Press tool for fitting drive flange.
 2409 Counterhold for drive flange.
 2412 Drift for fitting bearing on input shaft, for bearing in rear cover for output shaft, and for fitting input shaft in housing.

SVO

- No.
 2413 Drift for fitting oil seal in rear cover.
 2427 Universal joint for SVO 2487.
 2487 Hexagon spanner, 3/8", for upper gearbox bolts.
 2743 Guide pins for gearbox.
 4030 Extractor for oil seal on drive flange.
 4109 Stand for fixture SVO 2044.

When removing the gearbox, the following tool is also used:

- 2727 Lifting tool for engine.

Overdrive unit

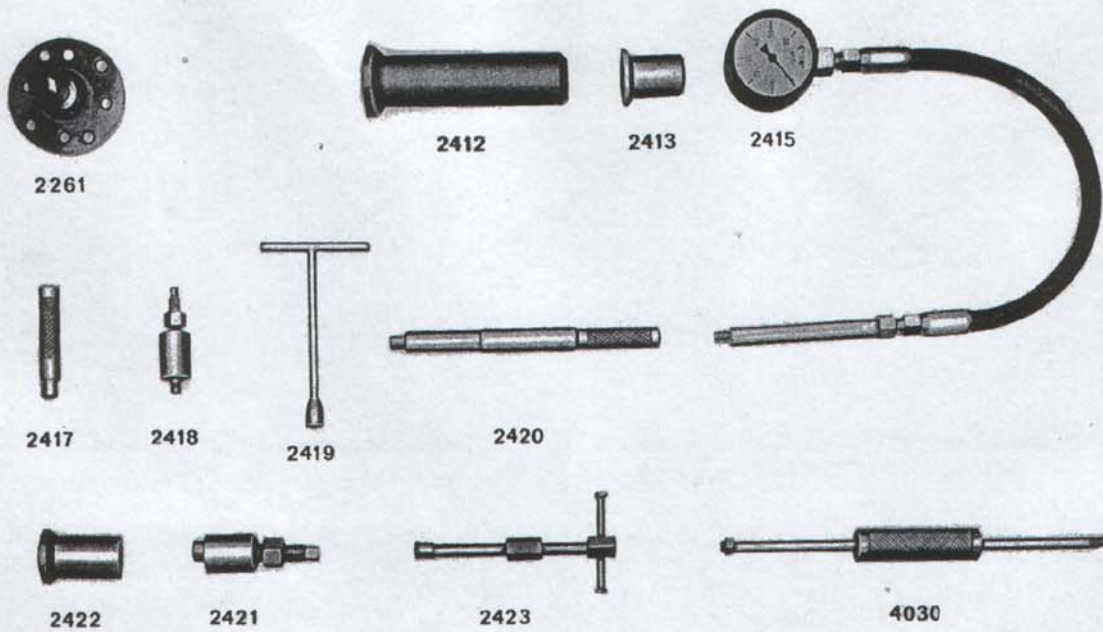

VOLVO
102 062

SVO
No.

- 2261 Puller for drive flange.
- 2412 Drift for fitting front bearing on output shaft.
- 2413 Drift for fitting rear bearing on output shaft.
- 2415 Pressure gauge for checking oil pressure.
- 2417 Drift for removing needle bearing in planet gear for fitting bearing in planet gear and output shaft.
- 2418 Extractor for oil pump.

SVO
No.

- 2419 Spanner for valve seat, oil pump.
- 2420 Centering tool for splines in planet gear carrier and one-way hub.
- 2421 Press tool for fitting drive flange.
- 2422 Drift for fitting oil seal, output shaft.
- 2423 Extractor for needle bearing in output shaft.
- 4030 Extractor for oil seal, output shaft.

Automatic gearbox

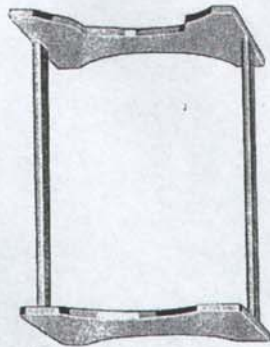

2530

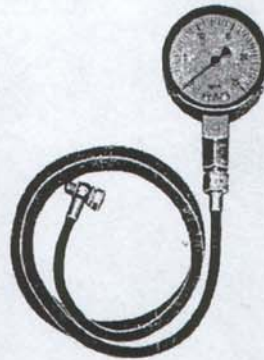

2531



2532



2533



2534



2535



2537



2538



2748

VOLVO
102 932

- SVO
No.
- 2530 Fixture for dismantling and assembling gearbox.
 - 2531 Pressure gauge complete with hose and connection for checking oil pressure.
 - 2532 Attaching plate for magnetic stand when measuring end float, input shaft.
 - 2533 Press tool for compressing clutch when removing and fitting locking ring.
 - 2534 Fitting ring for piston in rear clutch.

- SVO
No.
- 2535 Special 5/16" square sleeve for adjusting rear band.
 - 2537 Packing block for adjusting front band.
 - 2538 Spanner for lock nut, contact for starting lock and reversing light.
 - 2746 Fixture for gearbox when removing and fitting (not illustrated)
 - 2748 Torque wrench for adjusting front brake band.

BRAKES

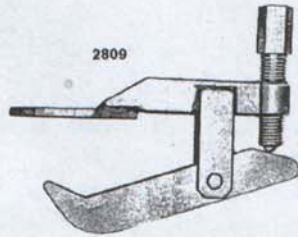
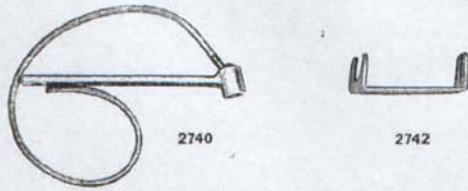

- SVO
No.
2740 Key for bleeding brake system.
2742 Holder for cable spring.
2809 Press tool for pressing in and checking
plunger in brake yoke.

VOLVO
163 033

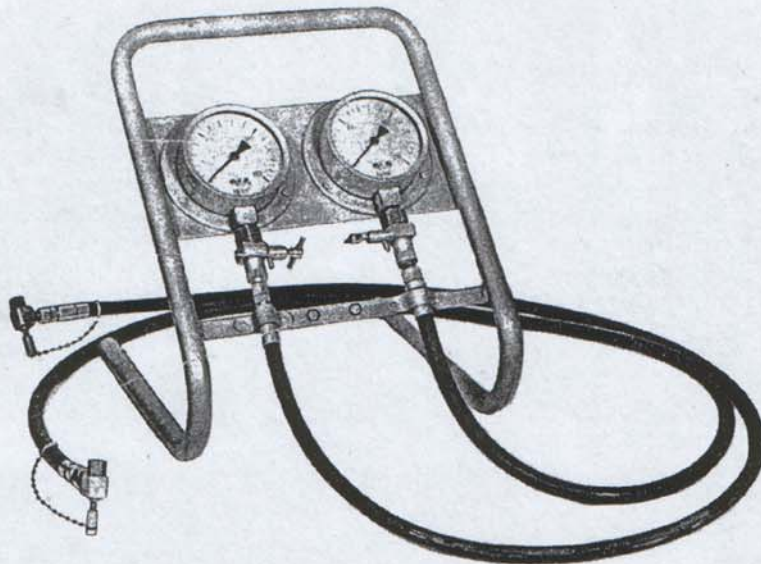

VOLVO
163 037

SVO 2741 Brake pressure gauge for testing
brake system.

FRONT END AND STEERING GEAR

Front axle

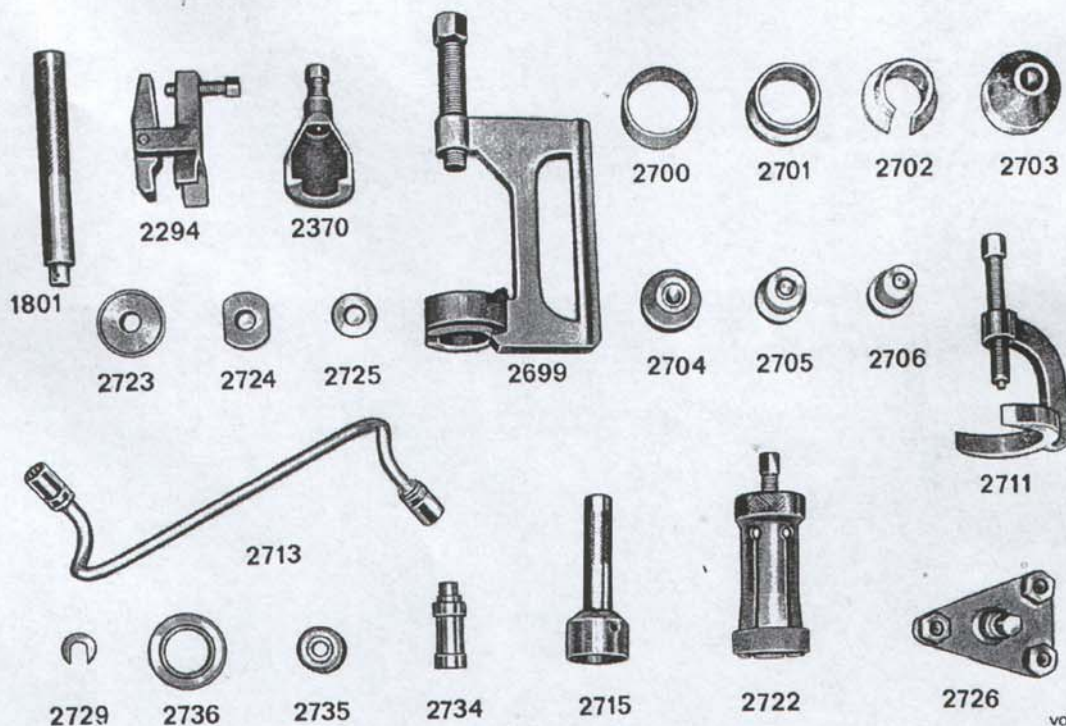
VOLVO
102 101

- SVO
No.
- 1801 Standard handle, 18x200 mm.
- 2294 Press tool for removing ball joint, tie rod end.
- 2370 Puller for pitman arm.
- 2699 Press tool for removing and fitting ball joints and rubber bushings, wishbones (used together with SVO 2700-2706).
- 2700 Sleeve for removing ball joint, lower wishbone, including SVO 2699. When fitting, also including SVO 2703.
- 2701 Sleeve for removing and fitting ball joint, upper wishbone; for fitting ball joint, lower wishbone and removing bushing, lower wishbone.
- 2702 Sleeve for removing and fitting rubber bushing, upper wishbone.
- 2703 Drift for fitting ball stud, lower wishbone.
- 2704 Drift for fitting ball stud, upper wishbone.
- 2705 Drift for removing and fitting rubber bushing in lower wishbone.
- 2706 Drift for fitting rubber bushing in upper wishbone, including SVO 2699 and SVO 2702.
- 2711 Puller for steering wheel.

- SVO
No.
- 2713 Socket spanner, 5/8", for bolt, upper wishbone shaft, adjustment of wheel alignment.
- 2715 Drift for removing and fitting grease cap on hub.
- 2722 Puller for inner ring, inner front wheel bearing.
- 2723 Drift for fitting outer ring, inner front wheel bearing and for oil seal in hub, including SVO 1801.
- 2724 Drift for fitting outer ring, outer front wheel bearing and for removing outer ring, inner front wheel bearing, including SVO 1801.
- 2725 Drift for removing outer ring, outer front wheel bearing, including SVO 1801.
- 2726 Puller for front wheel hub.
- 2729 Washer for removing shaft, upper wishbone.
- 2734 Drift for removing bushing, relay arm.
- 2735 Drift for removing bushing, relay arm.
- 2736 Cushioning ring for removing bushing, relay arm.
- 2520 Stand for fixture when reconditioning front axle.
- 2560 Fixture for front axle.

Steering box



2254



2716



2717



2718



1801



2720



2719



2721

VOLVO
102 092

SVO

No.

- 1801 Standard handle, 18x200 mm.
- 2254 Guide for reamer SVO 2721.
- 2716 Drift for fitting bushing, steering shaft, including SVO 1801.
- 2717 Drift for fitting upper bearing race, steering cam, including SVO 1801.
- 2718 Drift for removing upper bearing race, steering cam, including SVO 1801.

SVO

No.

- 2719 Sleeve for fitting oil seal, steering shaft.
- 2720 Tool for removing bushing, steering shaft.
- 2721 Reamer for bushing, steering shaft, including SVO 2254.

SUSPENSION, WHEELS



1801



2294



2722



2715



2726



2723



2724



2725



2730



2731



2732



2733

VOLVO
102 091

SVO No.	
1801	Standard handle, 18x200 mm.
2294	Puller for ball joint, steering rod.
2715	Drift for removing and fitting grease cap.
2722	Puller for inner ring, inner front wheel bearing.
2723	Drift for fitting outer ring, inner front wheel bearing and for oil seal.
2724	Drift for fitting outer ring, outer front wheel bearing, and for removing outer ring, inner front wheel bearing.
2725	Drift for removing outer ring, outer front wheel bearing.

SVO No.	
2726	Puller for front wheel hub.
2730	Drift for removing and fitting bushing in track rod and for small bushing in support arm (with SVO 2733).
2731	Drift for removing and fitting large bushing in support rod (with SVO 2733).
2732	Drift for removing and fitting front bushing, support arm.
2733	Cushioning ring for removing and fitting bushing, support arm, support rod and track rod.

BODY



2739



2744

VOLVO
400 240

SVO No.

- 2739 Holding clamp for gas spring, luggage door.
- 2744 Press tool for gas spring, luggage door.

B 18 ENGINE

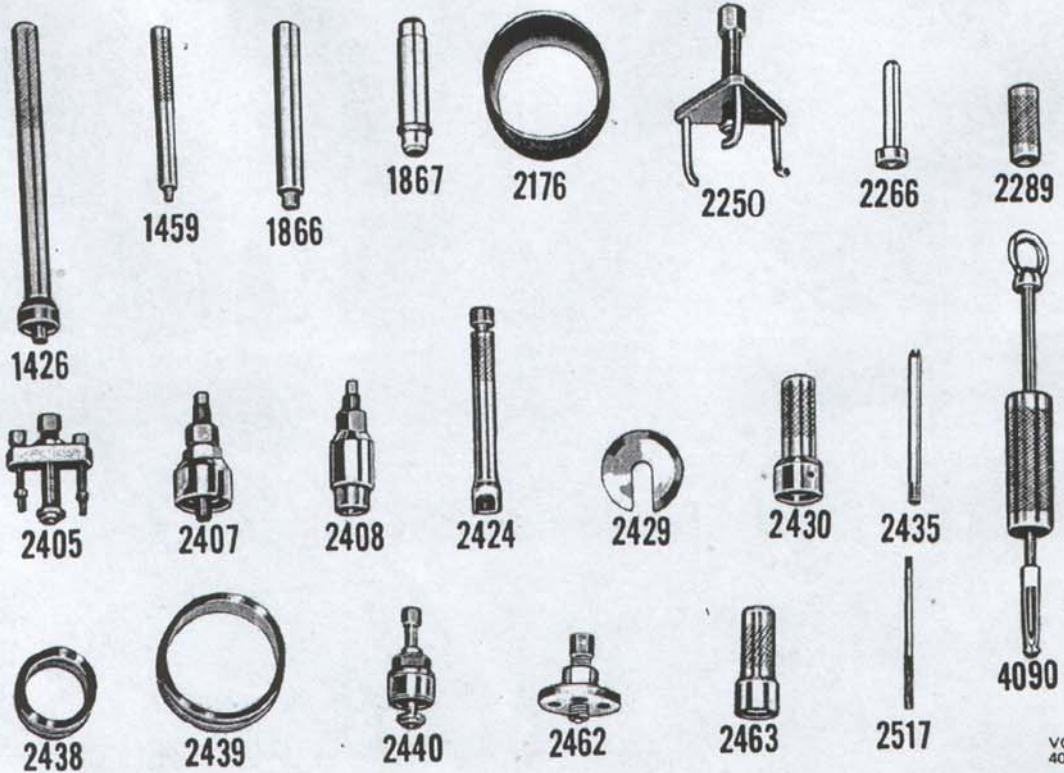

- SVO
No.
- 1426 Drift for fitting support bearing.
 - 1459 Drift for fitting valve guide.
 - 1866 Drift for removing and fitting gudgeon pin.
 - 1867 Drift for removing and fitting bushing in rocker arm and connecting rod.
 - 2176 Fitting ring for piston (standard diameter).
 - 2250 Puller for camshaft gear.
 - 2266 Drift for removing and fitting hub and impeller, water pump.
 - 2289 Drift for fitting valve guide.
 - 2405 Puller for crankshaft gear.
 - 2407 Press tool for fitting crankshaft gear.
 - 2408 Press tool for fitting camshaft gear.
 - 2424 Grip tool for removing and fitting valve tappet.
 - 2429 Press washer for removing impeller, water pump.

- SVO
No.
- 2430 Drift for fitting seal, water pump.
 - 2435 Guide pins for fitting cylinder head (two).
 - 2438 Centering sleeve for timing gear casing and for fitting circlip for felt ring.
 - 2439 Centering sleeve for rear sealing flange and for fitting circlip for felt ring.
 - 2440 Puller for hub on crankshaft.
 - 2462 Puller for hub, water pump.
 - 2463 Drift for removing and fitting bearing, water pump.
 - 2517 Reamer for valve guide.
 - 4090 Extractor for pilot bearing, flywheel.

SVO 2425 Lifting tool for B 18 engine.

SVO 2520 Stand with engine fixture SVO 2521. Used when reconditioning engine.

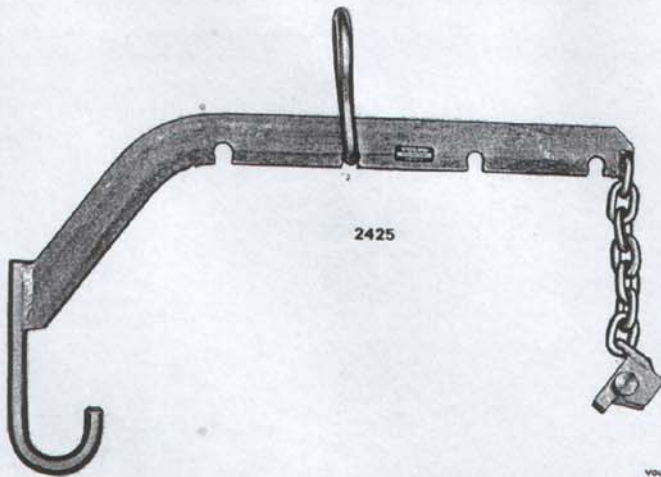

SVO 2425 Lifting tool for engine when replacing.

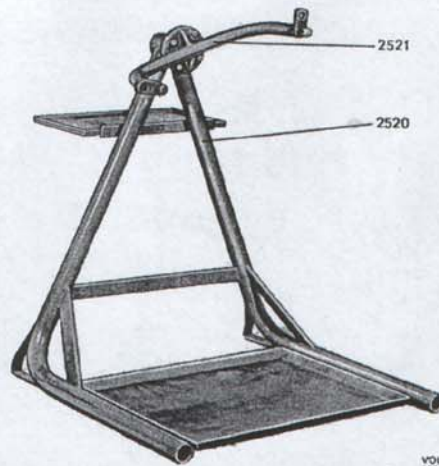

SVO 2520 Stand with engine fixture SVO 2521. Used when reconditioning engine.

POWER TRANSMISSION, REAR AXLE

Clutch

Clutch fixture SVO 2322 with accessories.

- A. Handle.
- B. Arm.
- C. Push rod.
- D. Bottom plate
- E. Packing block No. 3 (four)
- F. Packing block No. 2 (four)
- G. Packing block No. 1 (three)
- H. Packing block No. 0 (three)
- I. Measuring gauge with holder
- J. 3-point support (three)

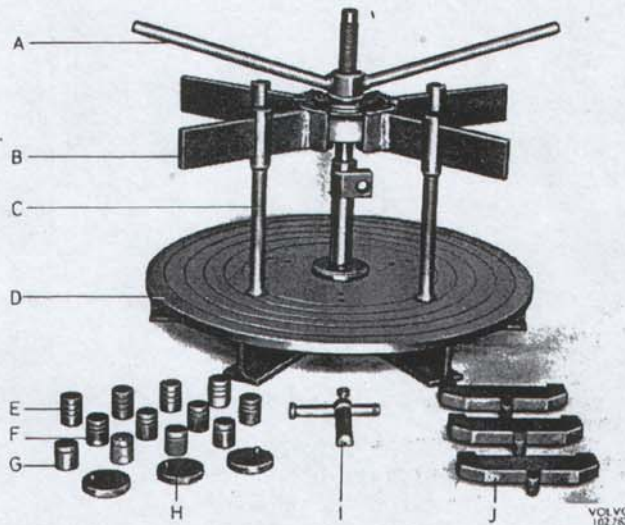

- SVO No. 1426 Drift for pilot bearing in flywheel.
- 2484 Mandrel for centering clutch disc.
- 4090 Extractor for ball bearing in flywheel.



Pedal shaft

- SVO No. 4084 Cramp for fitting pedal.
- 4088 Drift for pedal bushing.
- 4089 Cushioning ring for pressing pedal bushing in and out.



Gearbox

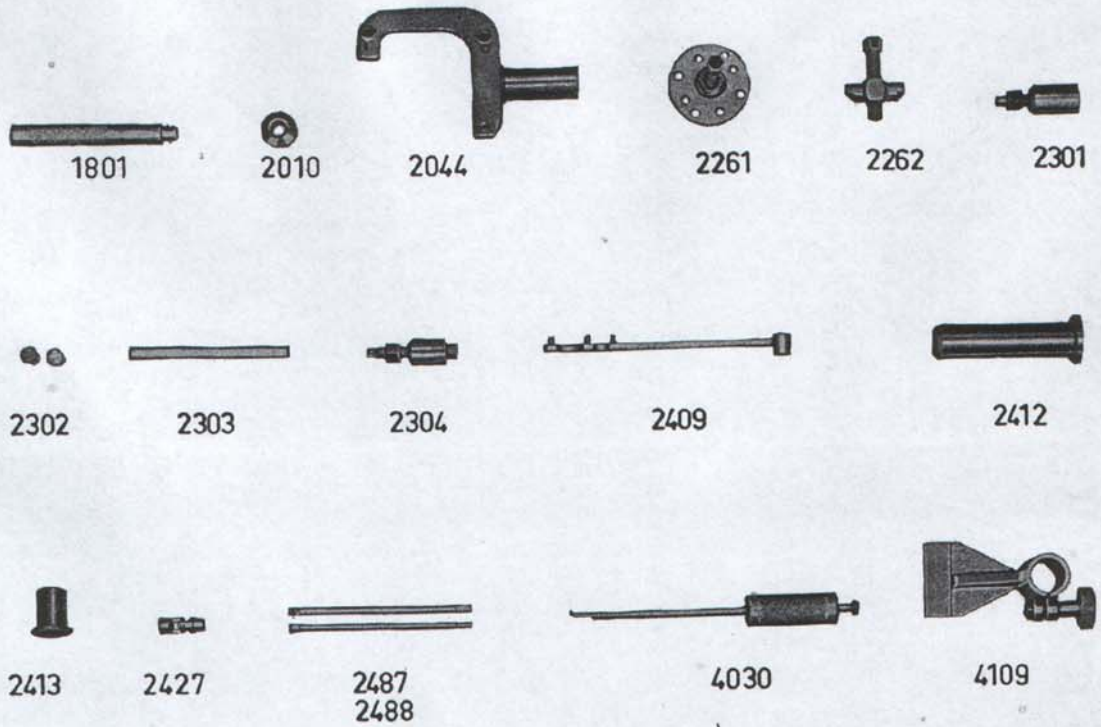

- SVO
No.
- 1801 Standard handle, 18x200 mm.
 - 2010 Drift for fitting oil seal in cover for input shaft.
 - 2044 Fixture for gearbox when dismantling and assembling. (Used together with SVO 4109.)
 - 2261 Puller for round drive flange.
 - 2262 Puller for drive yokes.
 - 2301 Extractor for removing reverse shaft.
 - 2302 Drift for thrust washer. Two are used together with SVO 2303 when fitting intermediate gear.
 - 2303 Drift for fitting intermediate gear.
 - 2304 Press tool for fitting drive flange.
 - 2409 Counterhold for drive flange.

- SVO
No.
- 2412 Drift for fitting bearing on input shaft, for bearing in rear cover for output shaft, and for fitting input shaft in housing.
 - 2413 Drift for fitting oil seal in rear cover.
 - 2427 Universal joint for spanners SVO 2487 and SVO 2488.
 - 2487 Hexagon spanner, 3/8", for upper gearbox bolts.
 - 2488 Hexagon spanner, 8 mm, for upper gearbox bolts.
 - 4030 Extractor for oil seal on drive flange.
 - 4109 Stand for fixture SVO 2044.

Y21W3
180 903

Propeller shaft

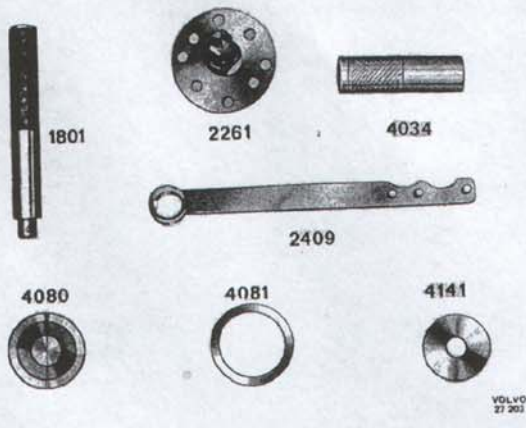

- SVO
 No.
 1801 Standard handle, 18x200 mm.
 2261 Puller for drive flange.
 4034 Drift for fitting drive flange.
 2409 Spanner for drive flange.
 4080 Drift for pressing in support bearing.
 4081 Cushioning ring.
 4141 Drift for pressing out support bearing.

Rear axle

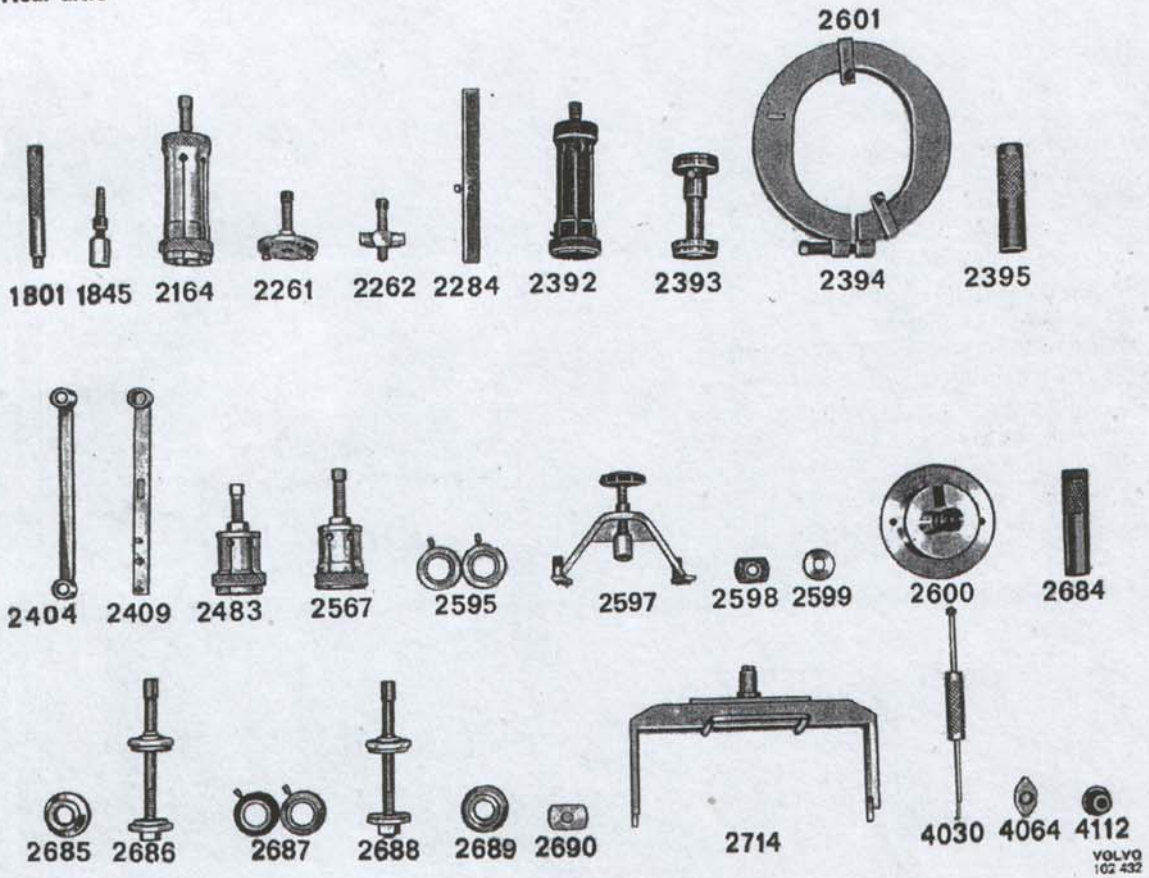

VOLVO
102 432

SVO No.		Used on	
		23	27,30
1801	Standard handle, 18x200 mm	X	X
1845	Press tool for fitting drive flange	X	X
2164	Puller for rear pinion bearing	X	
2261	Puller for round drive flange	X	X
2262	Puller for drive yokes	X	X
2284	Holder for dial gauge when adjusting final drive	X	X
2392	Puller for rear pinion bearing		X
2393	Measuring tool for adjusting pinion	X	X
2394	Expanding tool used when removing and fitting differential	X	X
2395	Fitting sleeve for inner ring, rear pinion bearing	X	X
2404	Spanner for fitting front pinion bearing	X	X
2409	Counterhold for drive flange	X	X
2483	Puller for differential carrier bearings		X
2520	Stand	X	X
2522	Fixture for rear axle (used together with stand SVO 2520 when working on final drive)	X	X
2567	Puller for differential carrier bearing	X	
2595	Adjusting rings for differential		X
2597	Brake for crown wheel. Used when checking tooth contact	X	X
2598	Drift for removing outer ring, rear pinion bearing		X
2599	Drift for removing outer ring, front pinion bearing		X
2600	Measuring fixture for adjusting rings	X	X
2601	Holder for expanding tool SVO 2394 (fitted on tool)	X	X
2684	Socket spanner for adjusting rings SVO 2685 and SVO 2689	X	X
2685	Adjusting ring for pinion		X
2686	Press tool for fitting outer rings of pinion bearings		X
2687	Adjusting rings for differential	X	
2688	Press tool for fitting outer rings of pinion bearings	X	
2689	Adjusting ring for pinion	X	
2690	Drift for removing outer ring, rear pinion bearing	X	
2714	Fixture for rear axle. Used on garage jack when removing and fitting rear axle	X	X
2806	Drift for fitting oil seal on drive flange (see Fig., page 40)	X	X
4030	Extractor for oil seal on drive flange	X	X
4064	Drift for removing outer ring, front pinion bearing	X	
4112	Drift for fitting differential carrier bearings	X	X

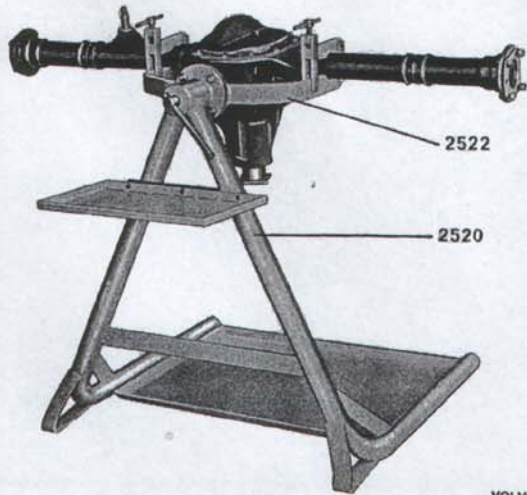

VOLVO
400 049

SVO 2520 Stand with fixture SVO 2522.
Used when working on the final drive.

Drive shaft

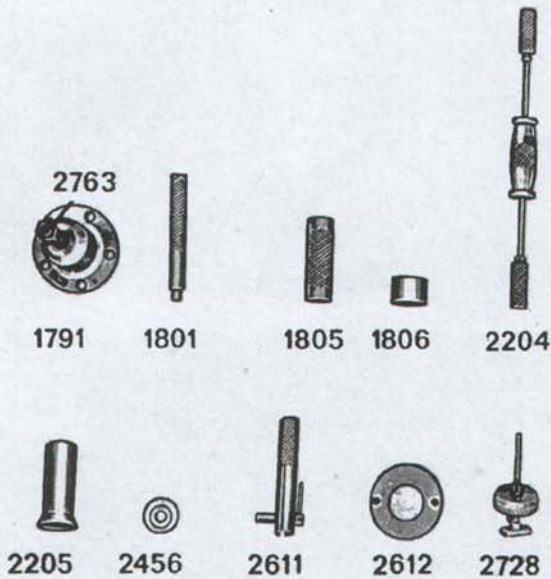

VOLVO
400 245

SVO
No.
1791 Puller for wheel hub.
1801 Standard handle, 18x200 mm.
1805 Fitting sleeve for drive shaft bearing.
1806 Cushioning ring for removing drive shaft bearing.
2204 Sleeve for fitting outer ring of bearing.
2205 Sleeve for fitting outer ring of bearing.
2456 Drift for fitting oil seal.
2611 Holder for dial gauge.
2612 Plate.
2728 Extractor for inner oil seal.
2763 Spindle for supplementing puller SVO 1791 so that the nut tightener can be used. (Shown fitted in SVO 1791 above).

BRAKES

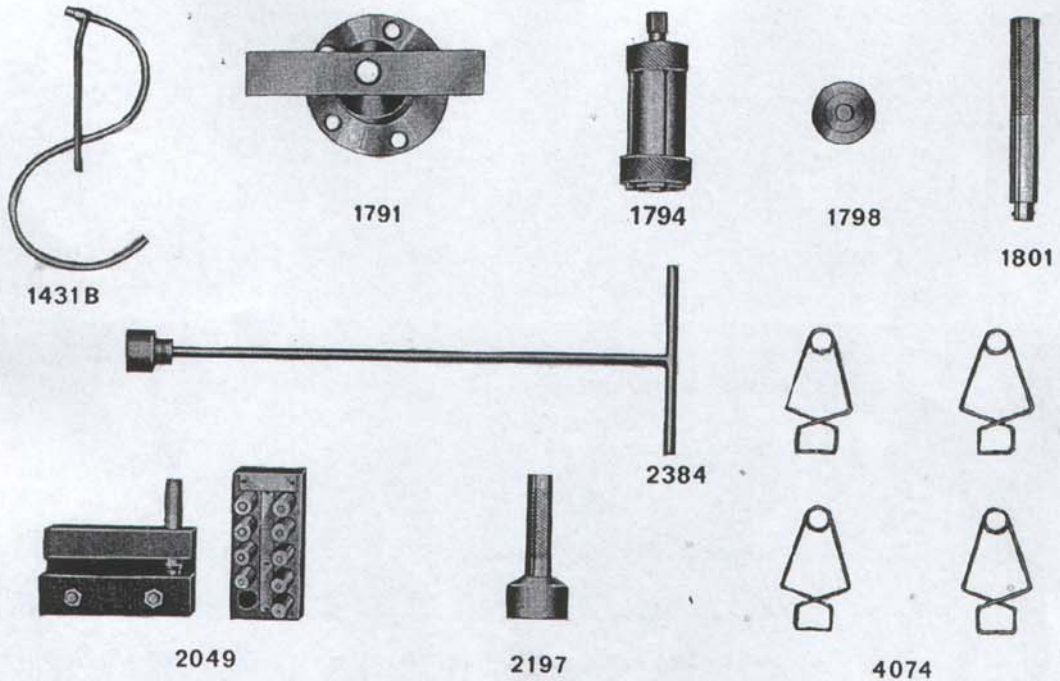

VOLVO
24284

- SVO
No.
1431 Key for bleeding nipple.
1791 Puller for hub and brake drum.
1794 Puller for inner bearing on steering knuckle.
1798 Drift for fitting oil seal in front wheel hub.
1801 Standard handle, 18x200 mm.

- SVO
No.
2049 Tool for flanging brake pipes.
2197 Drift for removing and fitting grease cap for front wheel hub.
2384 Spanner for master cylinder filling plug.
2763 Spindle for supplementing SVO 1791 so that the nut tightener can be used, see Fig., page 27.
4074 Spring clip for wheel cylinder.

FRONT END AND STEERING GEAR

Front axle

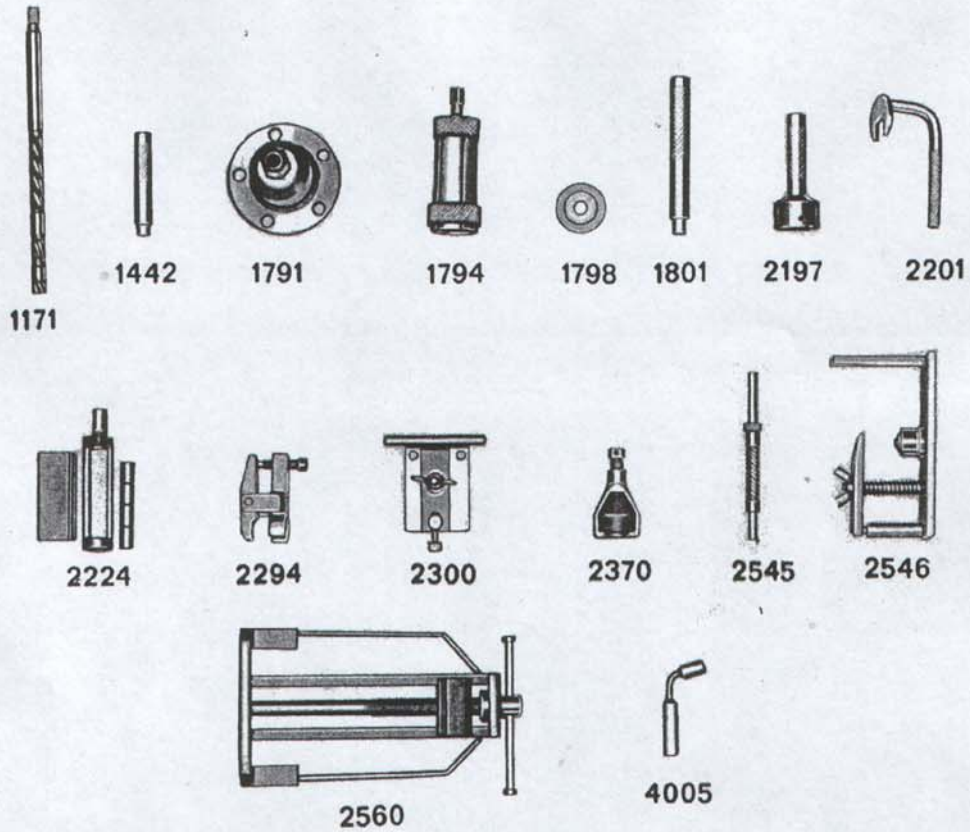

VOLVO
102 357

SVO
No.

- 1171 Reamer for king pin bushing. Alternatively SVO 2545.
- 1442 Drift for removing and fitting king pin bushing.
- 1791 Puller for front wheel hub.
- 1794 Puller for inner ring, inner bearing on steering knuckle.
- 1798 Drift for fitting oil seal in front wheel hub.
- 1801 Standard handle.
- 2197 Drift for removing and fitting grease cap.

SVO
No.

- 2201 Spanner for eccentric bushing.
- 2224 Tool for removing king pin.
- 2294 Tool for removing ball joint.
- 2300 Fixture for upper wishbone.
- 2370 Puller for pitman arm.
- 2545 Reamer for machine reaming.
- 2546 Stand for reamer SVO 2545.
- 2560 Fixture for front axle member. Used together with stand SVO 2520.
- 2763 Spindle for supplementing SVO 1791 so that the nut tightener can be used, see Fig., page 27.
- 4005 Centering tool for king pin.

Steering gear

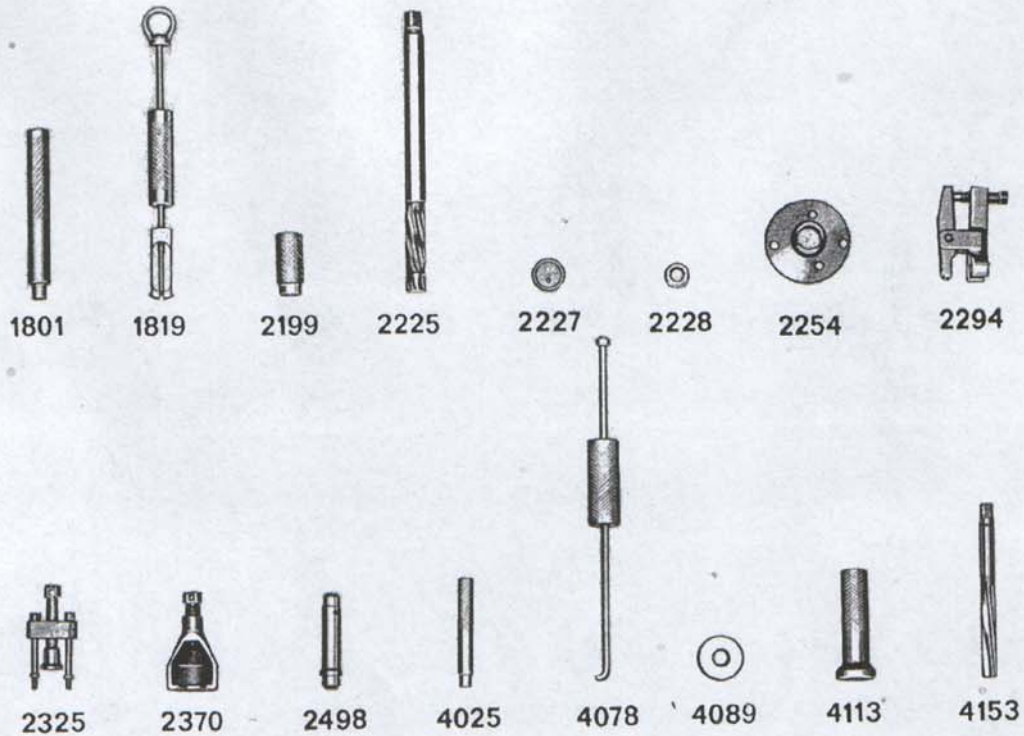

VOLVO
102 358

SVO

No.

- 1801 Standard handle, 18x200 mm.
- 1819 Extractor for upper bearing outer ring and steering shaft bushing.
- 2199 Protecting sleeve for oil seal when fitting steering shaft.
- 2225 Reamer for steering shaft bushings.
- 2227 Drift for fitting oil seal.
- 2228 Drift for fitting steering shaft bushing.
- 2254 Guide for reamer SVO 2225.
- 2294 Tool for removing ball joint.
- 2325 Puller for steering wheel.
- 2370 Puller for pitman arm.

SVO

No.

- 2498 Drift for removing and fitting bushings in relay arm bracket.
- 4025 Drift for removing and fitting relay arm bushing.
- 4078 Extractor for bearing in jacket tube.
- 4089 Cushioning ring for removing relay arm bushing.
- 4113 Drift for removing upper bearing outer ring.
- 4153 Reamer for bushings in relay arm bracket.

SUSPENSION, WHEELS

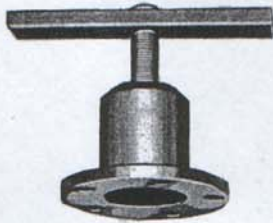

1791



1794



1797



1798



1799



1800



2197



1801

VOLVO
100 664

SVO

No.

- 1791 Puller for wheel hub.
- 1794 Puller for inner ring, inner wheel bearing.
- 1797 Drift for fitting outer bearing ring.
- 1798 Drift for fitting inner bearing ring and oil seal in hub.

SVO

No.

- 1799 Drift for removing inner bearing ring.
- 1800 Drift for removing outer bearing ring.
- 1801 Standard handle, 18x200 mm.
- 2197 Drift for fitting and removing grease cap.
- 2763 Spindle for supplementing SVO 1791 so that the nut tightener can be used, see Fig., page 27.



2764

SVO 2764 Tool for removing and fitting spring bushing.



VOLVO
400247

BODY

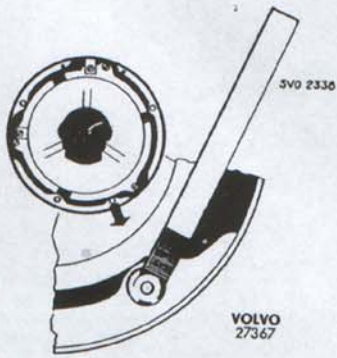

SVO 2338 Drilling bush for removing screw in headlamp casing.

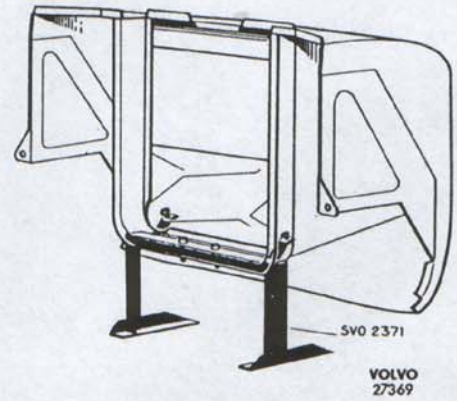

SVO 2371 Assembling trestle for front end.

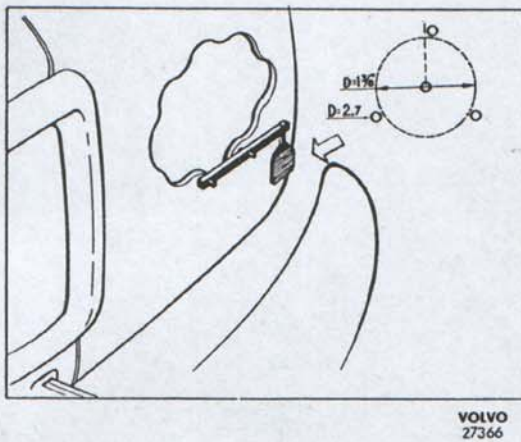

SVO 2475 Drilling template for drilling holes in front mudguard.



SVO 1460 Holder for removing door handle and window winder.

