

hydraulic servo units

Introduction

The Mk 2A Hydraulic Servo unit and Powerstop has been completely superseded by the Mk 2B unit. To save space therefore this manual page does not describe and illustrate how the unit works, but does provide the necessary Servicing, Testing and Fault Finding information.

Servicing

After 64,000 km (40,000 miles) or three years, whichever is reached first, the Mk 2A unit should be replaced by a new guaranteed Mk 2B unit. Alternatively, it should be completely dismantled and examined to see that the internal working surfaces are in perfect condition. Provided the parts are in perfect condition, new seals and gaskets can be fitted from the relevant Girling Service Kit: the unit will then be satisfactory for a further period of service. Where doubt exists concerning the condition of the parts, the unit should be scrapped and a new guaranteed Mk 2B unit should be fitted.

The vacuum pipe and filter element should be renewed when the unit is replaced or overhauled. In between service periods, the filter element should be changed whenever new brake shoes or pads are fitted.

Dismantling & Reassembly

A fitting instruction provided in the relevant Girling Service Kit gives full details of the correct procedure for dismantling and reassembling Mk 2A units.

Replacing a Mk 2A Unit

When replacing a Mk 2A unit with a Mk 2B unit, as the illustration shows, the two units are slightly different in shape and therefore minor modifications may be necessary on some installations. The changes fall into two categories:-

1. Vacuum Connections

The vacuum hose connection on Mk 2B units is in the vacuum shell and not, as with Mk 2A in the hydraulic body. It is therefore expected that the vacuum hose will need to be longer. A longer length of hose than the one originally fitted should therefore be obtained from your Girling distributor.

NEVER FIT HOSES MADE FROM SPURIOUS MATERIALS. USE ONLY THE RECOMMENDED PARTS.

In cases where banjo unions having a metal vacuum supply pipe are used, the pipe should be cut and a suitable length of vacuum pipe installed.

It is important to note that most Mk 2B units are fitted with a non-return valve. However, where vacuum tanks are part of the installation, it is **ESSENTIAL** that another non-return valve is fitted between the tank and the engine.

IMPORTANT: THE MK 2B NON-RETURN VALVE IS WHITE IN COLOUR. SOME UNITS INCORPORATE A SLAVE ADAPTOR COLOURED RED WHICH MUST BE REPLACED BY A WHITE NON-RETURN VALVE.

2. Vacuum Shell Clearance

Because the crimp band makes the Mk 2B unit slightly bigger overall, modifications may be necessary on some installations. In some cases, the fitting of spacers between the unit and brackets, would make alterations to the brackets unnecessary.

In conclusion, any installation changes will be relatively simple and difficulties are not expected, but where doubt exists, contact Girling Technical Service Department.

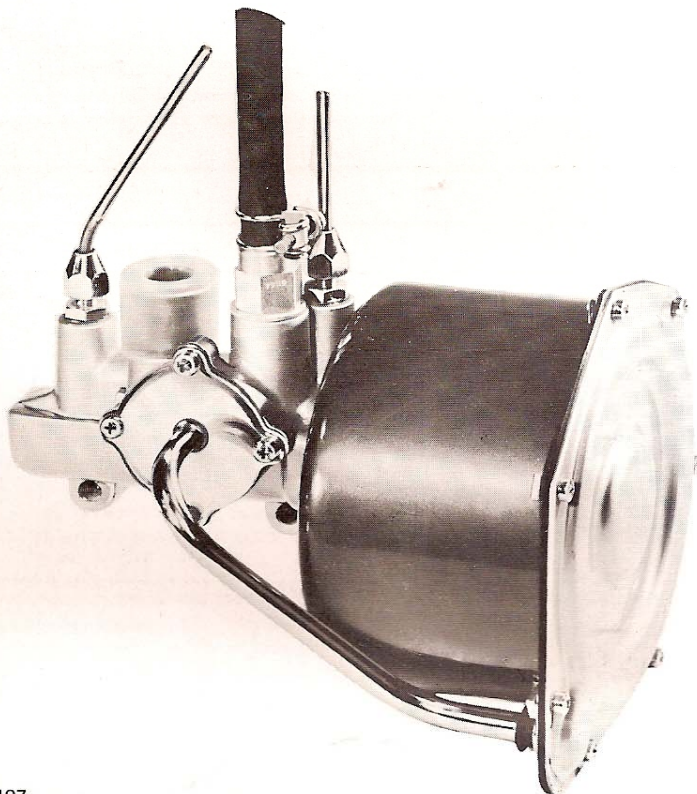
1 MK 2A SERVO UNIT

A0407

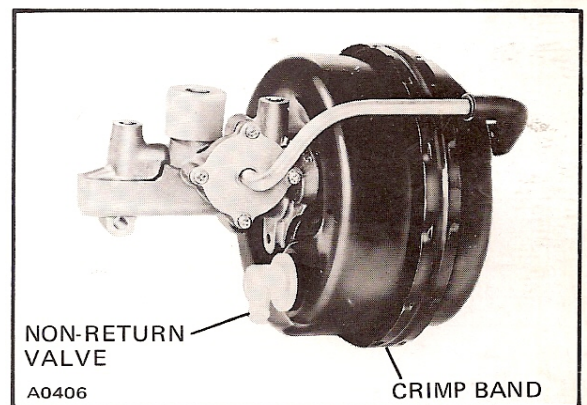

Testing

The use of these tests will assist in diagnoses and will provide assurance after servicing, but the tests are not exhaustive and obviously cannot equal the quality of testing which is done in the factory by the specially designed equipment. If a Servo Unit gives cause for doubt it is always best to replace it by a factory-tested unit whenever possible.

It is assumed that any faults connected with the brake system, such as contamination, lack of adjustment, air in the system, fluid leaks, etc., have been recognised and eliminated.

TEST 1

Fit the completed unit to the mounting brackets and, before connecting the pipes, fit a bleedscrew in the hydraulic outlet port and an adaptor shown in Fig. 2, into the hydraulic inlet port. Connect the Vacuum hose to the adaptor and remove the filter element. While the engine is "ticking over" place fingers over the air inlet and vacuum ports to determine if there is any suction at either orifice. If suction can be detected it indicates that the bores are scored or the components incorrectly assembled.

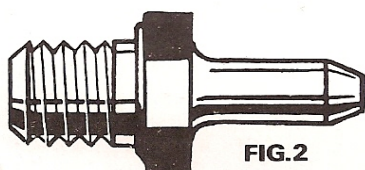

FIG. 2

TEST 2

Connect up the hydraulic and vacuum pipes and bleed the system. Run the engine and, while the brake is being applied, it should be possible to hear the hiss of the air inlet and, with a hand on the vacuum cylinder, feel the movement of the unit working.

TEST 3

Run the engine for half-a-minute, switch off and leave for two minutes. Apply the brake and the Servo unit should operate and the operation should be detected as detailed in test 2.

TEST 4

Run the engine and apply the brake hard, and hold it for fifteen to twenty seconds. There should be no perceptible creep of the pedal. If there is it indicates leaks or scored bores in the components.

TEST 5

Jack up the front wheels and with the engine running apply the brake and release. The wheels should be free to move half-a-second after the release of the pedal.

Tests 2 to 5 can be used to test a suspect Servo unit before it is removed from the car.

If the result is unsatisfactory on:-

TEST 2

It means the unit is not working at all which could be caused by a lack of vacuum, possibly a faulty non-return valve, or a fault within the unit.

TEST 3

It indicates leaking gaskets, air valve or rubber grommet. To test non-return valve and grommet, run the engine for half-a-minute, clamp the vacuum hose, switch off engine and leave for two minutes. Apply the brake and the Servo unit should operate and the operation should be detected as detailed in test 2. If satisfactory the non-return valve is faulty. To test for a leaking air valve remove clamp from vacuum hose, run the engine and place the finger over the air inlet. If the suction is only slight the air valve is satisfactory and the leak is elsewhere.

TEST 4

The source of trouble can only be found by elimination. Check for leaks. If no leak of hydraulic fluid is evident clamp each hose successively and repeat test each time. Finally plug the master cylinder outlet and test. If creeping of the pedal is evident when the hoses are clamped and the pedal is solid when the master cylinder outlet is plugged, the Servo Unit is faulty.

TEST 5

If the brakes remain on, disconnect the vacuum pipe, operate the brakes to eliminate all vacuum in the Servo Unit and make the test again. If the brakes remain on, the fault is not in the Servo Unit. If the brakes now release normally, the fault is in the Servo Unit and the vacuum piston alignment is suspect. See kit fitting instructions.

Fault Finding

FAULT	CAUSE	ACTION
Hard Pedal — apparent lack of assistance with engine running.	Lack of vacuum. Restricted hose. Blocked air inlet. Rubber grommet swollen. Faulty output piston. Major fault in unit.	Check vacuum connections. Check hose and replace if necessary — fit parts from Service Kit — examine filter and air inlet — fit new unit.
Brakes hanging on.	Misaligned vacuum piston (after servicing unit). Swollen rubber grommet or swollen backing ring.	Check as Test No. 5. Replace parts as necessary.
Slow action of Servo Unit.	Swollen rubber grommet. Blocked filter or restricted air inlet.	Check and replace as necessary. Tighten vacuum connections. Replace hose.
Lack of assistance on heavy braking. Servo operating only when engine is running. Poor slow running of engine.	Air leak in servo low vacuum. Air leaks in gaskets or air valve. Vacuum hoses or faulty non-return valve.	Check for vacuum leaks, if unsuccessful, dismantle and replace all parts in Service Kit. Tighten vacuum connections. Replace vacuum hose or replace non-return valve.
Loss of fluid.	Failure of a seal or seals in unit or scored bores.	Replace unit or fit a Service Kit of seals and gaskets.

hydraulic servo units

Introduction

The Girling Hydraulic Servo Unit takes wasted power from the engine and uses it to boost the hydraulic pressure in the brake system. On many vehicles the unit is fitted as original equipment, but not all cars have power assisted brakes and a unit called the Powerstop was therefore introduced by Girling to offer any car owner the luxury of ample power at the brake pedal. Obviously, the same boost ratio would not suit all vehicles, and both the Hydraulic Servo Unit and the Powerstop are available with boost ratios to accommodate the various installations. The Hydraulic Servo Unit and Powerstop have been established now for many years and sold world-wide by Girling.

This manual page deals with the Mk 11B Hydraulic Servo Unit and Powerstop, which superseded the Mk 11A. The external differences between the two units can be seen from the illustration (Fig. 1). Internally the basic design is unchanged but small improvements have been made and these are (1) operational 'clonk' has been eliminated by the anti-knock output piston, (2) the vacuum piston has been replaced by a diaphragm and; (3) the vacuum connection is now in the vacuum chamber and not the hydraulic body. The design of the vacuum chamber and the retaining band, which holds the two halves of the shell together, makes the outside shape slightly different but, with few exceptions it is expected the Mk 11B unit will eventually replace the Mk 11A in service.

1

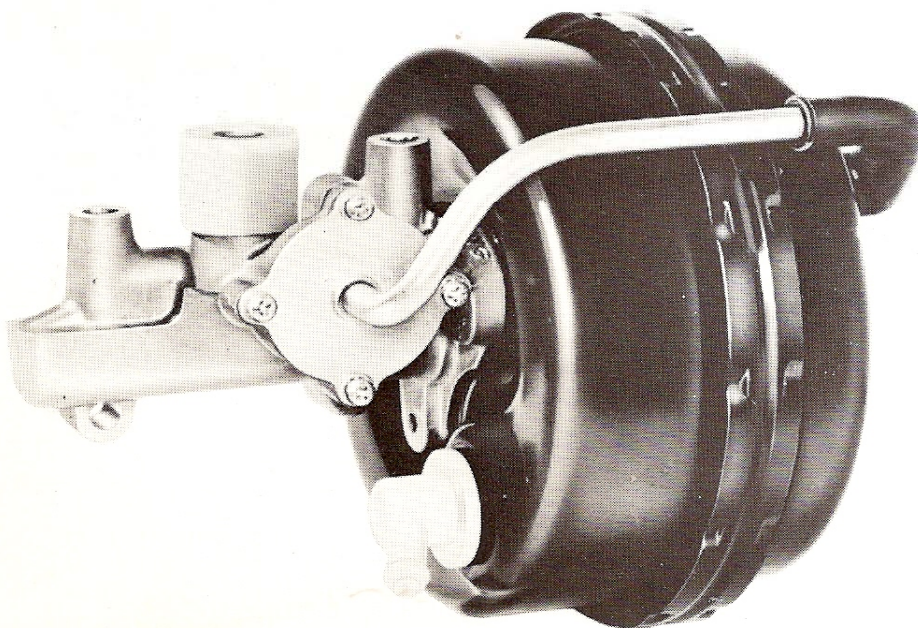

MK IIA SERVO UNIT

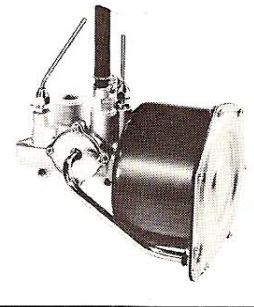

hydraulic servo units

returns and with it the output piston, relieving the pressure to the wheel cylinders as shown on Fig. 5. The piston sleeve lifts the ball and allows the fluid to move unrestricted between the supply tank and wheel cylinders.

If the force on the pedal is increased after arriving at the position shown on Fig. 4, the valve gear operates to give additional assistance from the diaphragm until the thrust on each end of the control piston is balanced or until the limit of available vacuum is reached. Conversely, if the foot pedal force is reduced the valve gear operates to reduce the pressure at the brake cylinders until again, a state of balance of the control piston is reached. The difference in area between the two opposed ends of the control piston determines the proportion of assistance provided by the unit. If, for example, the large end is twice the area of the small end, the hydraulic pressure output is built up to twice that of the input from the master cylinder before the control piston moves back to close the air valve. Such a unit therefore would have an output of twice the pressure of the input, throughout the range of the unit.

In this way, the pressure in the wheel cylinders varies in proportion to the effort at the pedal, and full and precise control of the brakes is always at the command of the driver. Some units have an input to output boost ratio of $2\frac{3}{4}$ to 1, some have a boost ratio of 2 to 1, and the Powerstop (type 5156) has a boost ratio of $1\frac{1}{2}$ to 1.

Between the engine inlet manifold and the vacuum reserve tank, or, if a tank is not fitted, between the manifold and the servo unit, is a non-return valve. This valve retains vacuum

in the tank or servo unit so that power operation of the brakes is possible for a limited period, should a vacuum failure occur. Fig. 6 shows the types of non-return valves in use: Type 'A' screws directly into the engine manifold; Types 'B' and 'C' are usually fitted in the servo body of Mk 11A units; and Type 'D' which is a push fit in the rear shell of the unit and may have a straight or right angled nozzle. Type 'D' is white in colour so that it can be distinguished from the slave adaptor coloured red. If a red slave adaptor is fitted in the rear shell instead of a white type 'D' non-return valve, a non-return valve must be fitted at some other point in the vacuum line.

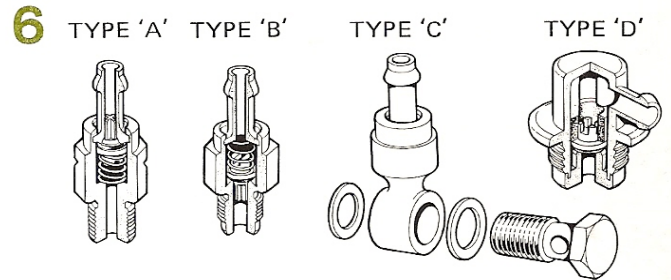

Type 'A' works in the opposite way to types 'B', 'C' and 'D' as the half ball, or plate valve, is in the opposite end of the valve body. The illustration shows the arrangement of the internal parts of types 'A' and 'B', and also shows the 'V' cuts in the hexagon body which identify type 'A'.

4 BRAKE HELD ON

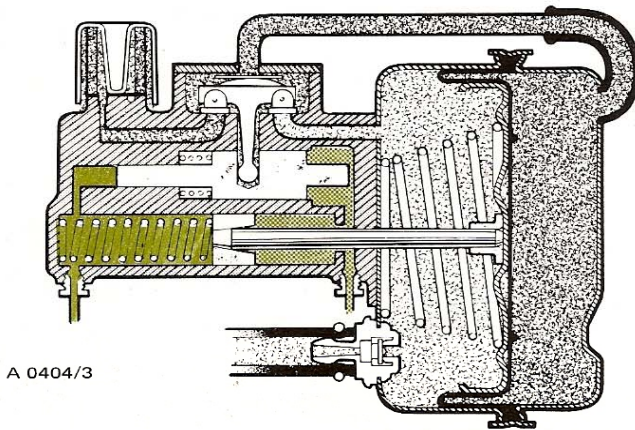

A 0404/3

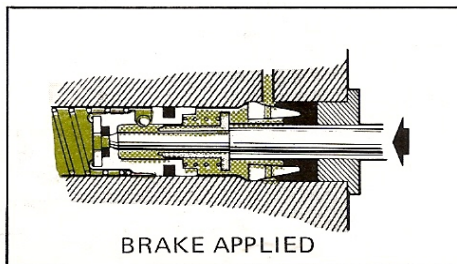

A 0405/1

5 BRAKE RELEASED

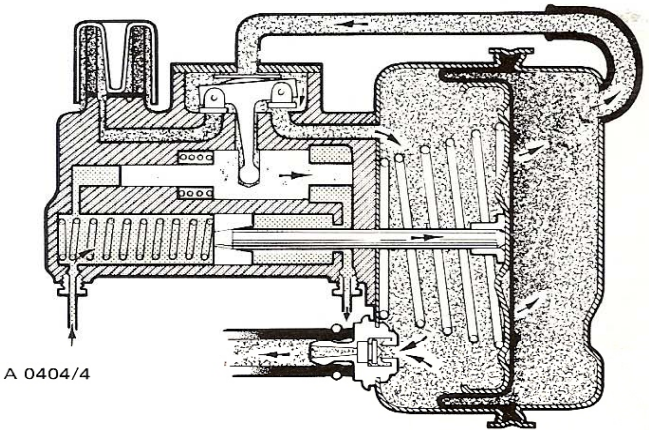

A 0404/4

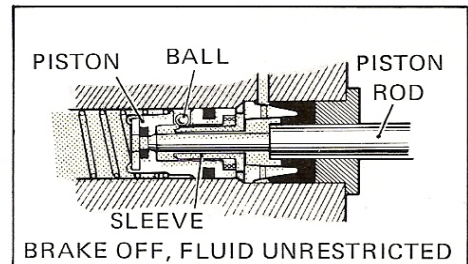

A 0405/2

Servicing

After 40,000 miles (64,000 km) or three years, whichever is reached first, the Servo or Powerstop should be replaced by a new guaranteed unit, alternatively, it should be completely overhauled and the diaphragm, seals and gaskets changed using the parts from the relevant Girling Service Kit. Provided the internal working surfaces are in perfect condition, the unit will be satisfactory for a further period of service, but where doubt exists concerning the condition of the parts, a new guaranteed unit should be fitted.

The vacuum pipe and filter element should be renewed when the unit is replaced or overhauled. In between service periods, the filter element should be changed whenever new brake shoes or new disc brake pads are fitted.

Listed below are the kits available to service the unit; the relevant parts contained in each kit can be seen on the illustration (Fig. 7).

MAJOR OVERHAUL KIT

- Rubber Sleeve
- Plug
- Diaphragm
- Body Gasket
- Copper Washers (three)
- Plug Seal
- Control Piston Seal (primary)
- Control Piston Seal (secondary)

- Piston Rod Gland Seal
- Output Piston Seal
- Output Piston Assembly
- Clamping Ring
- Valve Chest Cover Gasket
- Grommet (non-return valve)
- Girling Grease No. 64949009

FILTER KIT

- Filter Element
- Filter Base Washer

NON-RETURN VALVE KIT

- Non-return Valve
- Grommet
- Girling Grease No. 64949009.

KEY

- | | |
|------------------------------|---|
| 1. CONTROL SEAL (SECONDARY) | 26. COVER GASKET (VALVE CHEST) |
| 2. CONTROL PISTON | 27. 'T' LEVER VALVE ASSEMBLY |
| 3. CONTROL SEAL (PRIMARY) | 28. ANTI-KNOCK OUTPUT PISTON ASSEMBLY |
| 4. SPRING ABUTMENT | 29. SERVICE CLAMPING RING |
| 5. SPRING | 30. DIAPHRAGM PLATE & PISTON ROD ASSEMBLY |
| 6. RETAINER | 31. DIAPHRAGM |
| 7. CIRCLIP | 32. CLAMPING RING |
| 8. PLUG | 33. FRONT SHELL |
| 9. PLUG SEAL | 34. RUBBER SLEEVE |
| 10. BUSH | 35. PLUG |
| 11. PISTON ROD GLAND SEAL | 36. VACUUM PIPE |
| 12. SPACER | 37. ABUTMENT WASHER |
| 13. SLEEVE | 38. (COPPER) WASHER |
| 14. PISTON SLEEVE SPRING | 39. CLAMPING PLATE |
| 15. OUTPUT PISTON SEAL | 40. GROMMET |
| 16. ANTI-KNOCK OUTPUT PISTON | 41. NON-RETURN VALVE/ ADAPTOR |
| 17. BALL | 42. HYDRAULIC BODY |
| 18. OUTPUT PISTON SPRING | 43. VALVE |
| 19. PISTON STOP | 44. VALVE SPRING |
| 20. COVER | 45. 'T' LEVER |
| 21. FILTER ELEMENT | 46. SPRING PLATE |
| 22. FILTER BASE WASHER | 47. LEVER GUIDE |
| 23. BODY GASKET | 48. SPRING CLIP |
| 24. REAR SHELL | |
| 25. DIAPHRAGM RETURN SPRING | |

7

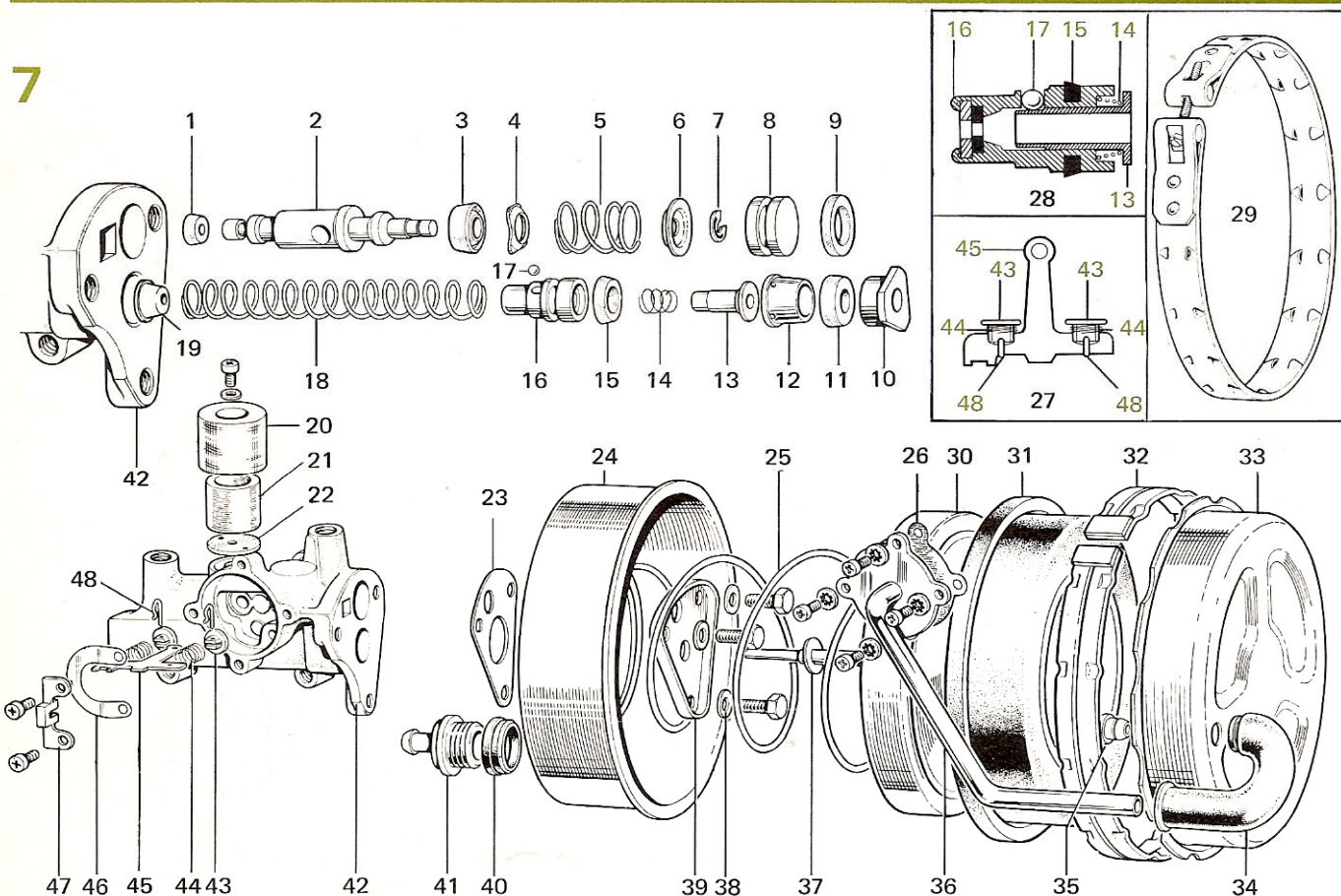

hydraulic servo units

Dismantling

A support plate is required (Fig. 8) to dismantle and re-assemble the unit. If the unit is held in the vice by one of the body mounting lugs, damage to the lug may occur necessitating a new unit.

Bolt the support plate to the body and clamp the plate in the vice so that the small plate welded to the clamping ring is uppermost (refer to Fig. 9). On some units the plate may be in a diametrically opposed position on the clamping ring and the unit would therefore be in an inverted position to that shown on the illustration. Before commencing to dismantle the unit, scribe a line across the two halves of the shell adjacent to the small plate, thus enabling the shells to be re-assembled in the same relative positions.

Connect one end of a vacuum hose to the non-return valve/adaptor and the other to the engine inlet manifold. Start the engine, the vacuum will draw the two halves of the shell to-

gether. Cover or blank off the hydraulic ports to prevent the entry of filings and saw through the centre of the plate (Fig. 9) taking care not to damage the shells.

Lever the clamping ring from the shell with a screwdriver (Fig.10) and remove. To allow air to enter the unit and break the vacuum lock, loosen and remove the setscrews securing the valve chest cover. It is important to press firmly with the body against the front shell whilst using the hands to remove the setscrews with a Phillips screwdriver, otherwise the diaphragm return spring may cause the two shells to fly apart. Remove the front shell and spring (Fig. 11). Switch off the engine and remove the vacuum hose from the non-return valve/adaptor. Pull the vacuum pipe from the rubber sleeve. Lever the sleeve from the front shell with a flat screwdriver (Fig. 12), but first remove the support plug from the sleeve by inserting a Phillips screwdriver down the centre and levering it out.

Re-position the unit in vice (Fig. 13) and unscrew the three bolts retaining the rear shell to the body. Remove the clamping plate with care as the output piston spring may eject the parts from the bore. If the parts are not ejected, withdraw the bush and hook out the piston rod gland seal when the output piston spring will then eject the anti-knock output piston, piston sleeve spring and ball; but provided care is used these parts will be caught in the rear shell..

Remove the rear shell and lever out the non-return valve by inserting a large screwdriver between the rubber grommet and valve. Remove the grommet and body gasket.

Unscrew the setscrews and remove the lever guide and spring plate from the valve chest (Fig. 14). Before the 'T' lever valve

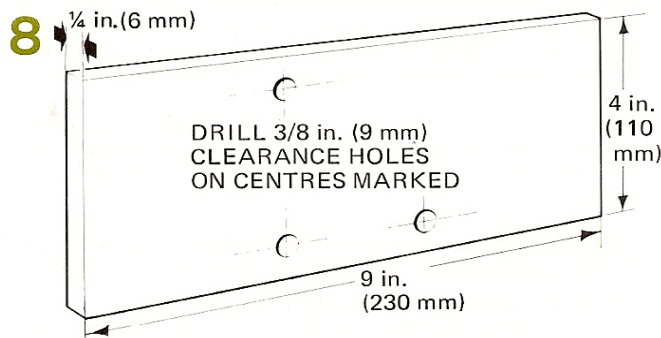

A 0408/1

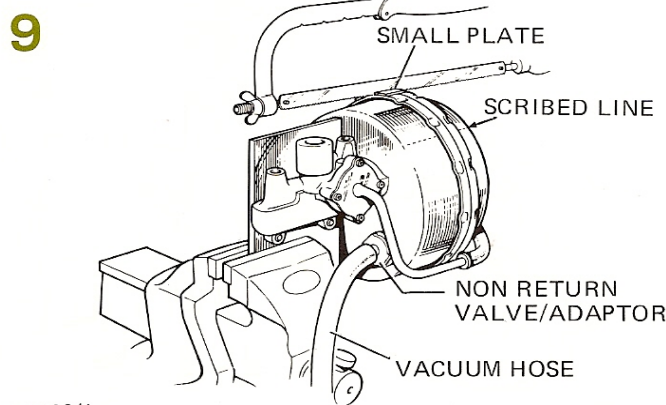

A 0093/1

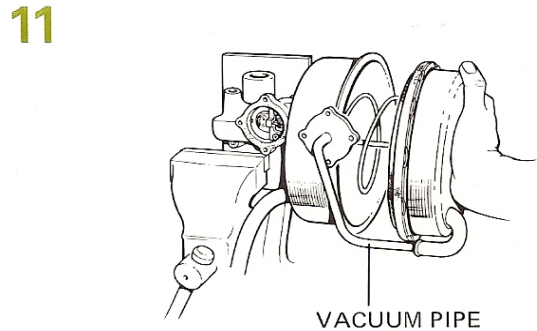

A 0093/3

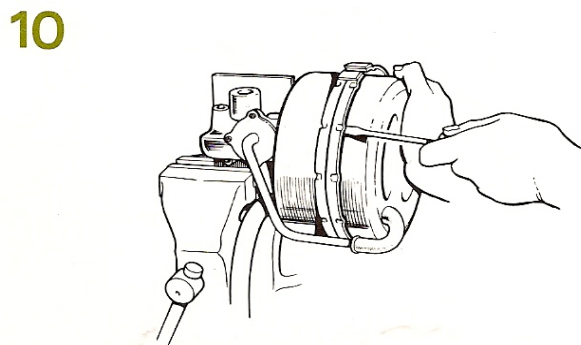

A 0093/2



A 0093/4

can be withdrawn, it is usually necessary to depress the plug in the body.

Insert a suitable bent rod into the hole in the control piston and lever the piston along to push out the plug (Fig. 15). Remove the control piston from the bore and compress the spring to remove the circlip, retainer and spring abutment. Remove the seals from the plug and control piston.

Unscrew the setscrew and remove the air filter and associated parts (Fig. 16).

Cleaning

Scrupulous cleanliness is now essential. Wash the hands before proceeding, and lay out a clean sheet of paper on which to place the parts. The Girling Service Kit contains all the parts necessary for a normal service overhaul and indicates which used parts should be discarded.

Do not handle the new diaphragm more than is absolutely necessary and keep it clean and dry at all times.

Clean the remaining parts thoroughly with Girling Cleaning Fluid, or clean Castrol-Girling Brake Fluid and place them on the sheet of paper and allow to dry. Examine each part to see it is undamaged and in good working order. Special attention should be given to the pistons and piston bores in the hydraulic body, there should be no signs of corrosion, pitting, scoring or ridges.

Assembling

Lubricate the control piston, piston seals and bore with clean, unused Castrol-Girling Brake Fluid. Fit the seals to the piston so that the lips face away from the centre hole. Fit the spring

abutment, spring, retainer and circlip to the piston, and insert into the bore; the piston centre hole should align with the valve chest. Fit the seal to the plug and press into the body.

Insert the rocking 'T' lever into the valve chest. The round end of the lever should fit in the hole in the control piston, if necessary press in the plug to locate lever in the piston. Place the spring plate and lever guide in position on the lever, ensuring the slot in the spring plate engages the lug above one of the lever valves, secure with setscrews.

Position the body in the vice as shown on Fig. 14 and lubricate the output piston bore and seal with clean, unused Castrol-Girling Brake Fluid. Fit the seal to the anti-knock piston so that the seal lips face the reduced end of the piston. Refer to Fig. 17 and with the rear shell in position on the body, fit the anti-knock piston and associated parts into the bore. Care must be taken to ensure the ball remains in the piston and does not drop down the bore. Until the clamping plate is fitted, the parts must be retained in the bore by hand pressure (Fig. 18). Position the plate and secure with bolts and washers. Remove the unit from the vice.

Fit the non-return valve/adaptor grommet (Fig. 19) to the rear shell. Lubricate the ribs of the non-return valve/adaptor with Girling Grease No. 64949009 and push fully home in the grommet.

Fit the rubber sleeve to the front shell (Fig. 20) lubricate the plug with Girling Grease No. 64949009 and insert as shown.

Fit the new diaphragm to the vacuum piston and place in the front shell. Position the return spring, with large diameter

13

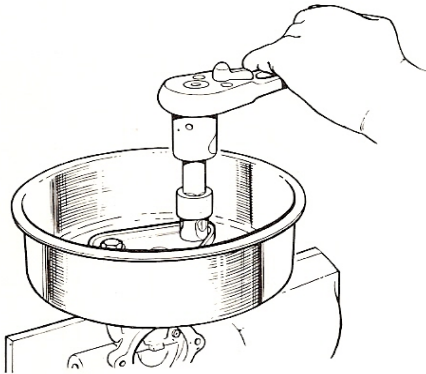

A 0093/5

15

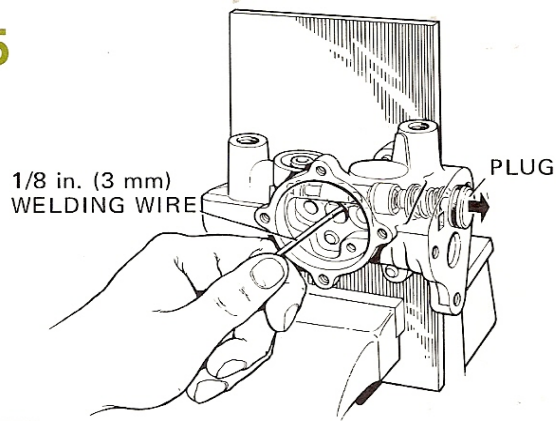

A 0108/2

14

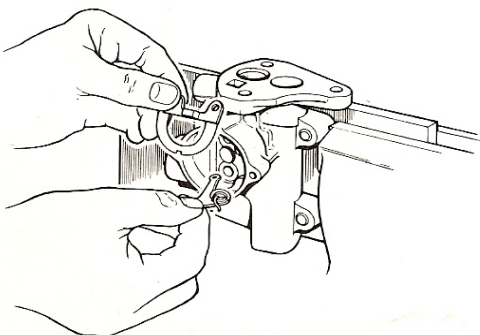

A 0093/6

16

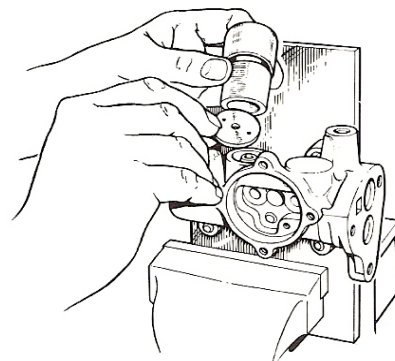

A 0093/7

hydraulic servo units

leading on the diaphragm plate. Re-position the unit in the vice in the manner shown on (Fig. 9) and place the new retaining band, with bolt and nut, loosely in position on the rear shell. Refit the vacuum hose to the non-return valve/adaptor. Fit the gasket and vacuum pipe to the valve chest and secure with the four setscrews and washers.

Switch on the engine and offer the front shell, complete with vacuum piston and diaphragm, to the rear shell so that the scribed lines are in alignment. When the elbow grommet is pushed onto the vacuum pipe the vacuum should hold the two halves of the unit together. The retaining band must be positioned so that the securing bolt and raised legs will not prevent the unit being re-fitted on the vehicle in its original position. Also ensure the small convex 'V' pressings engage the level sections on the front shell rim.

Position the clamping ring on the shells and slowly tighten the bolt whilst tapping each side of the ring with a hammer to ensure the small 'V' pressings are in position on the edge of the shells and pressing them together. When the bolt cannot be tightened further; bend up the lockwasher, fit the filter element and test for leaks (see Testing Page 6a 2h).

17

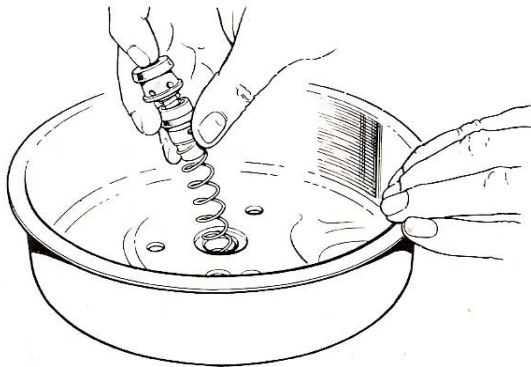

A 0408/2

19

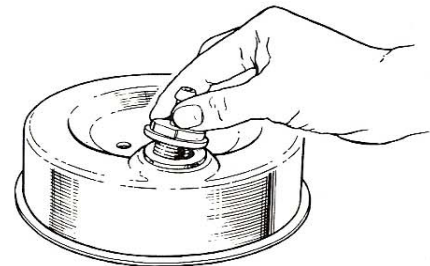

A 0093/8

18



A 0408/3

20

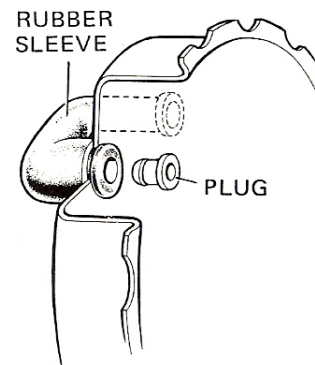

A 0108/1

Testing

The use of these tests will assist in diagnosis and will provide assurance after servicing, but the tests are not exhaustive and obviously cannot equal the quality of testing which is done in the factory by the specially designed equipment. If a Servo Unit gives cause for doubt it is always best to replace it by a factory-tested unit whenever possible.

It is assumed that any faults connected with the brake system, such as contamination, lack of adjustment, air in the system, fluid leaks etc., have been recognised and eliminated.

TEST 1

Connect up the hydraulic and vacuum pipes and bleed the system refer to Section 1, Page 1D1).

Start the engine and as the brake is applied, it should be possible to hear the 'hiss' of the air inlet and, with a hand on the centre of the front shell, feel the movement of the unit working. With the brakes held on there should be no 'hiss' from the air inlet

Unsatisfactory result on TEST 1

It means the unit is not working at all which could be caused by a lack of vacuum, possibly a faulty non-return valve, or a fault within the unit.

TEST 2

Run the engine for half a minute, switch off and leave for two minutes. Apply the brake and the Servo Unit should operate and the operation should be detected as described in Test 1.

Unsatisfactory result on TEST 2

It indicates leaking gaskets, air valve or rubber grommet. Run the engine, clamp the vacuum hose and repeat test. If satisfactory the non-return valve is faulty. To test for a leaking air valve run the engine and place the finger over the air inlet. If the suction is only slight the air valve is satisfactory and the leak is elsewhere.

TEST 3

Run the engine and apply the brake hard, and hold it for fifteen to twenty seconds. There should be no perceptible creep of the pedal. If there is, it indicates leaks or scored bores in the components. If the pedal pushes back the hydraulic connections may be reversed or there is a fault in the unit.

Unsatisfactory result on TEST 3

The source of the trouble can only be found by elimination. Check for leaks. If no leak of hydraulic fluid is evident clamp each hose successively and repeat test each time. Finally plug the master cylinder outlet and test. If creeping of the pedal is evident when the hoses are clamped and the pedal is solid when the master cylinder outlet is plugged, the Servo Unit is faulty.

These tests can be used to test a suspect Servo Unit before it is removed from the car.

Fault Finding

FAULT	CAUSE	ACTION
Hard pedal — apparent lack of assistance with engine running.	Lack of vacuum. Restricted hose. Blocked air inlet. Faulty output piston. Major fault in unit.	Check vacuum connections. Check hose and replace if necessary — fit parts from Service Kit — examine filter and air inlet — fit new unit.
Slow action of servo unit.	Blocked filter or restricted air inlet. Faulty vacuum hose or connections.	Change filter. Tighten vacuum connections. Replace hose.
Lack of assistance on heavy braking. Servo operating only when engine is running. Poor slow running of engine.	Air leak in servo low vacuum. Air leaks in gaskets, non-return valve grommet, rubber sleeve, diaphragm or air valve. Vacuum hoses or faulty non-return valve.	Check for vacuum leaks, if unsuccessful, dismantle and replace all parts in Service Kit. Tighten vacuum connections. Replace vacuum hose or replace non-return valve.
Loss of fluid.	Failure of a seal or seals in unit or scored bores.	Replace unit or fit a Service Kit of seals and gaskets.
Pedal pushes back.	Hydraulic inlet and outlet pipe wrongly connected, or fault in unit.	Re-connect pipes or dismantle unit.