

**CARS**

Part 8

BODY

P 1800

# **SERVICE MANUAL**

## Contents

Description .....	1
Body frame .....	1
Bonnet .....	2
Doors and openings .....	2
Interior fittings and upholstery .....	2
Front seats .....	2
Rear seat .....	2
Door upholstery .....	2
Headlining .....	3
Covering for bulkhead and floor .....	3
Bumpers .....	3
Repair instructions .....	4
Front end .....	4
Bonnet and bonnet lock .....	4
Removing bonnet .....	4
Doors .....	4
Removing and fitting doors .....	4
Removing inner handles and door upholstery .....	4
Door locks and door handles .....	6
Removing door locks and outer handles .....	6
Dismantling door handles .....	6
Fitting and adjusting locks .....	6
Fitting and adjusting outer handles, late production .....	7
Fitting and adjusting outer handles, early production .....	7
Latch plates .....	7
Ventilation windows .....	8
Removing and fitting, with frame, late production .....	8
Removing and fitting, with frame, early production .....	9
Removing and fitting, without frame, late production .....	9
Removing and fitting, without frame, early production .....	9
Winding window with winding mechanism .....	9
Removing and fitting, late production .....	9
Removing and fitting, early production .....	10
Sealing strips .....	10
Bonded strips .....	10
Strips attached with rails .....	10
Luggage compartment lid .....	11
Dismantling lock for luggage compartment lid .....	11
Removing tank cover and lock .....	12
Trim mouldings .....	12
Waist mouldings .....	12
Window mouldings .....	12
Trim mouldings, windscreen and rear window .....	12
Removing .....	12
Fitting .....	13
Windows .....	13
Removing windscreen .....	13
Fitting windscreen .....	14
Rear window .....	15
Removing and fitting .....	15
Rear quarter light .....	15
Removing and fitting .....	15
Seats .....	15
Front seats .....	15
Removing .....	15
Adjusting .....	15
Rear seat .....	15
Removing backrest .....	15
Upholstery .....	16
Replacing headlining .....	16
Instrument panel .....	16
Removing instrument panel .....	16
Plates. Control drawing for body floor	

## DESCRIPTION

### Body frame

The Volvo P1800 has an integral body (monocoque) so that there is no independent chassis frame. The body is composed of a number of pressed steel plates, each of which forms part of the supporting construction.

The main parts of the body consist of the floor, side sections, rear section, scuttle, roof section, front mudguards, doors, luggage compartment and bonnet.

The floor section (Fig. 1) consists of the front and rear floor plates (1 and 3) and inner cantrail (5), front and rear cross-members (8 and 6), tunnel (10) and scuttle (Fig. 2). The floor plates are welded to the rear seat support.

The rear floor plate has longitudinal reinforcing members underneath on either side and a number of cross-members between them. One of the cross-members (6) is provided with an attaching piece (7) for the rear axle track rod.

There is a flanged hole in the rear floor plate for attaching the fuel tank, the upper part of which forms part of the floor in the luggage compartment. The scuttle (Fig. 2) consists of the bulkhead (7), wheel arches (5), front upper cross-member (4) and side plate (3) as well as lower cross-members (1 and 2). The bulkhead forms the front transverse wall of the body and has welded end plates. Two front side members (8) project from the front floor section. They are joined together at the front by means of a cross-member (2) and are attached at the rear to the front cross-member under the front seats. Two side members (6) project from the upper corner between the bulkhead and front pillar. They are spot-welded to the front pillar, front side plate and wheel arch plates. The front axle member and bumper support bars are attached to the side members. The roof section consists of a number of plates. The roof plates form the upper part of the scuttle, the windscreen opening and the actual roof.

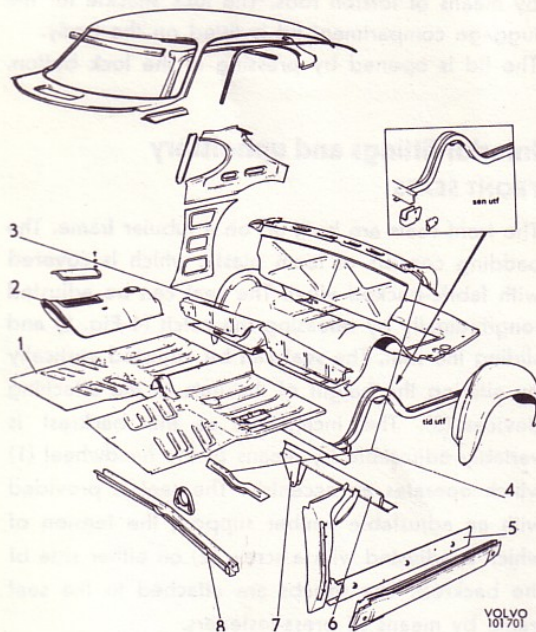


Fig. 1. Floor section.

- |                       |                                       |
|-----------------------|---------------------------------------|
| 1. Front floor plate  | 6. Rear cross-member                  |
| 2. Tunnel             | 7. Attachment for rear axle track rod |
| 3. Rear floor plate   | 8. Front cross-member                 |
| 4. Reinforcing member |                                       |
| 5. Inner cantrail     |                                       |

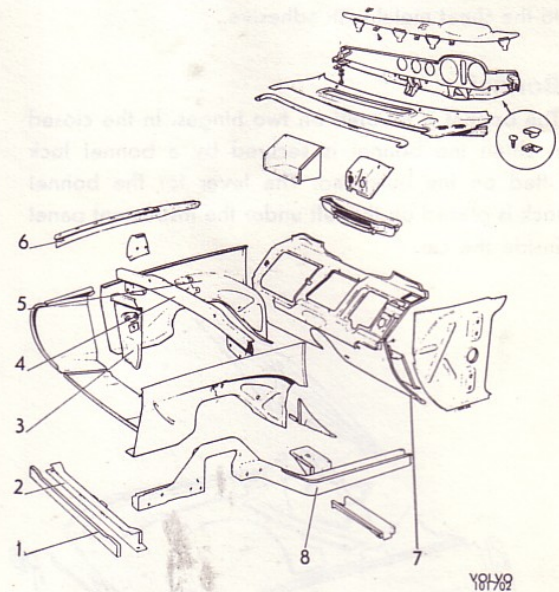


Fig. 2. Scuttle.

- |                             |                             |
|-----------------------------|-----------------------------|
| 1. Front lower cross-member | 4. Front upper cross-member |
| 2. Front lower cross member | 5. Wheel arch               |
| 3. Side plate               | 6. Upper side member        |
|                             | 7. Bulkhead                 |
|                             | 8. Front side member        |

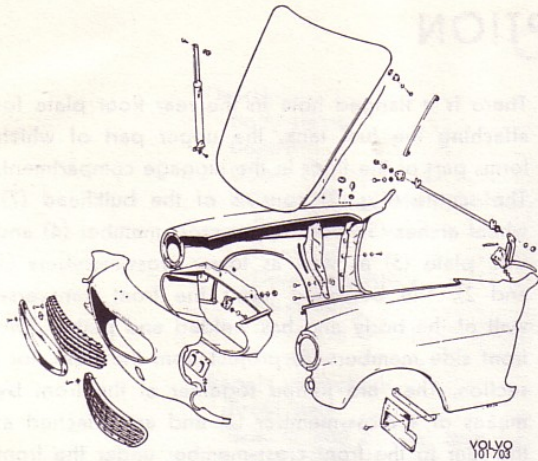


Fig. 3. Front end.

The front end consists of the front mudguards, front section and bonnet. The front end is welded to the upper side member, front cross-member and front pillar. The front mudguards are welded to the wheel arch plates. The front section forms the front part of the front end and the air intake to the radiator. The body is insulated against noise and heat. The insulation consists of chequer board which is stuck to the sheet metal with adhesive.

### Bonnet

The bonnet is pivoted on two hinges. In the closed position the bonnet is secured by a bonnet lock fitted on the bulkhead. The lever for the bonnet lock is placed on the left under the instrument panel inside the car.

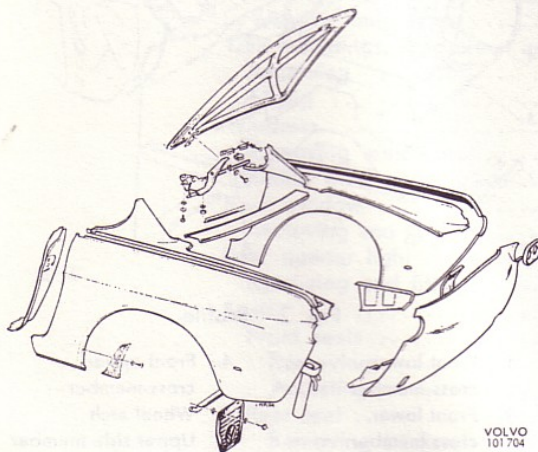


Fig. 4. Rear end.

## Doors and openings

The doors are made up of an inner and outer plate which are beaded and spot-welded together. The hinges are fitted on the inner plate. The doors are adjustable both longitudinally, vertically and laterally.

The door locks are fitted to the doors with screws. The press button of the outer door handle operates a lever which in turn releases a rotating toothed roller (lock plunger). The inner door handle is fitted to the remote control which is attached to the inner door plate with screws. The handle transmits the movement of the toothed roller by means of a linkage system. The lock insert is fitted in the press button on the door handle.

The window winders are of the lifting arm and toothed segment type. When the winding handle is turned, two parallel lifting arms, one of which is attached to a toothed segment, move the window to the required position.

The luggage compartment is built up of an inner and outer plate. The lock is fitted at the lower edge of the luggage compartment lid. The hinges, which are bolted to the body, are fitted at the upper edge of the lid. The luggage compartment lid is balanced by means of torsion rods. The lock shackle for the luggage compartment lid is fitted on the body. The lid is opened by pressing in the lock button.

## Interior fittings and upholstery

### FRONT SEATS

The front seats are built up on a tubular frame. The padding consists of foam plastic which is covered with fabric-backed vinyl. The seat can be adjusted longitudinally by releasing the catch (4 Fig. 5) and sliding the seat. The seat can be adjusted vertically by altering the height of the nuts of the attaching devices (3). The inclination of the backrest is variably adjustable by means of the handwheel (1) which operates an eccentric. The seat is provided with an adjustable lumbar support, the tension of which is adjusted with a screw (2) on either side of the backrest. The squabs are attached to the seat frame by means of press-fasteners.

### REAR SEAT

The rear seat and backrest have the same upholstery as the front seats. The seat frame consists of a wooden frame and the padding is of foam plastic.



Fig. 5. Front seat, late production.

1. Handwheel for adjusting backrest inclination
2. Adjustment for lumbar support
3. Attachments for vertical adjustment
4. Catch for longitudinal adjustment

### DOOR UPHOLSTERY

The door upholstery consists of two wood-fibre panels lined with non-woven padding and covered with upholstery material. It is secured to the door by means of clips. The front armrest, which is made of moulded plastic, forms part of the lower door upholstery.

### HEADLINING

The headlining consists of plastic fabric stretched on a wood-fibre frame provided with ribs and is secured to the upper edge of the body sides by means of clips.

### COVERING FOR BULKHEAD AND FLOOR

The sides of the bulkhead are lined with millboard which is attached with clips. The bulkhead is covered with plastic-lined felt matting. The floor is covered with rubber mats.

### BUMPERS

The bumpers are composed of three parts which are fitted on four support bars. The front support bars are attached to the front side members and the rear support bars to the rear side members.

# REPAIR INSTRUCTIONS

## Front end

The front mudguards and front section are welded together and also welded to the upper and lower longitudinal members, bulkhead and radiator air intake, see Fig. 3.

## Bonnet and bonnet lock

### REMOVING BONNET

1. Remove the pin for the bonnet support and lay down the bonnet.
2. Remove the radiator grille by unscrewing the four screws, bending the grille together slightly and pulling it straight out.
3. Unscrew the two screws on each hinge and lift off the bonnet.

The bonnet lock is fitted on the bulkhead and controlled by means of a lever from the driving seat. The downward tension of the bonnet is adjusted partly by screwing the rubber stops (Fig. 6) up or down, and partly by placing packing pieces under the locking hooks on the bonnet. The lock shackles are bolted to the rear corners of the bonnet and should be lubricated with paraffin wax when adjusting.

To remove the transverse shaft of the lock, first unscrew the nut on the handle inside the car. Then unscrew the two screws for the transverse shaft attachment on the right-hand side inside the engine compartment, after which the shaft can be pulled out to the right.

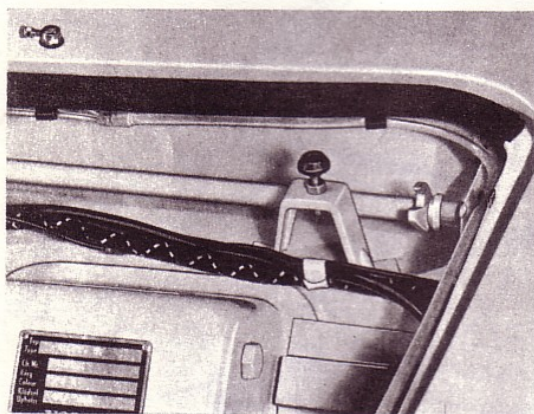


Fig. 6. Bonnet lock and rubber stop.

## Doors

### REMOVING AND FITTING DOORS

When removing without the hinges, carry out operations 1—5 under the heading "Removing inner handles and door upholstery".

The door can be removed with or without the hinges fitted. If the door is removed with the hinges remaining in the body, the doorstop need not be removed. If the door is removed with hinges attached, i.e. the door is taken off at the body attachment, the doorstop must be taken apart. This is done by knocking or drilling out the guide pin. The hinges are accessible after the inside upholstery panel has been removed. When fitting, the door can be adjusted longitudinally and vertically since the diameter of the holes for the screws in the body is larger than the diameter of the screws. The door is adjusted laterally by means of packing pieces.

### REMOVING INNER HANDLES AND DOOR UPHOLSTERY

1. Remove the window winding handle (late production) by pressing the trim washer up against the upholstery and then against the winding handle in the same direction as the handle as shown in Fig. 7. This releases the circlip and the winding handle can then be removed. On earlier cars, the winding handle is taken off by removing the clip with a hook which is inserted between the door upholstery and trim washer of the winding handle, after which the clip can be pulled out and the handle removed, see Fig. 8.



Fig. 7. Removing winding handle, late prod.

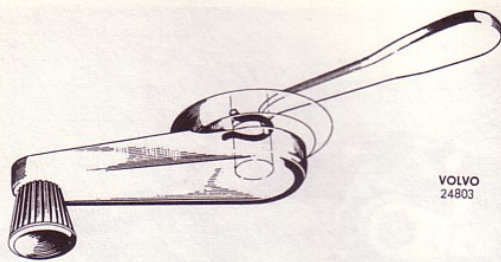


Fig. 8. Removing winding handle, early prod.

2. Unscrew the two screws which are fitted in the upper door panel.
3. Remove the upper door panel by carefully applying a screwdriver or similar under the edge of the upholstery and prising outwards as shown in Fig. 9. When the clip has released from the door, the upholstery is removed upwards.
4. Then unscrew the two screws for the rail on the upper edge of the lower upholstery (Fig. 10) and the two screws in the upholstery, after which the upholstery is prised out with a screwdriver as described above. In this case the upholstery is pulled straight out, when the armrest comes out with it.
5. Remove the plastic protection, which is only attached with tape.
6. The inner handle is removed by knocking out the pin with a suitable punch as shown in Fig. 11, after which the handle can be taken off.

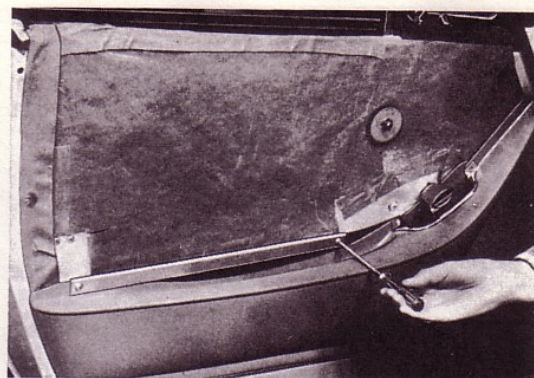


Fig. 10. Removing clamping rail for lower upholstery.

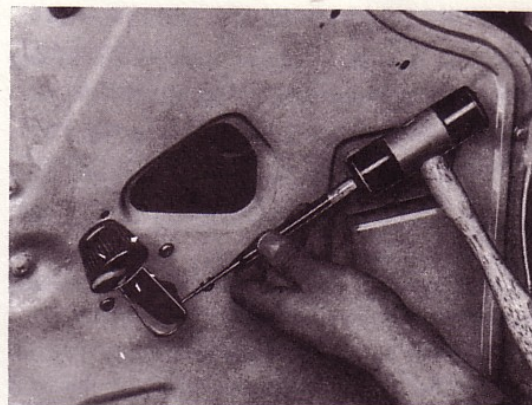


Fig. 11. Removing inner lock handle.

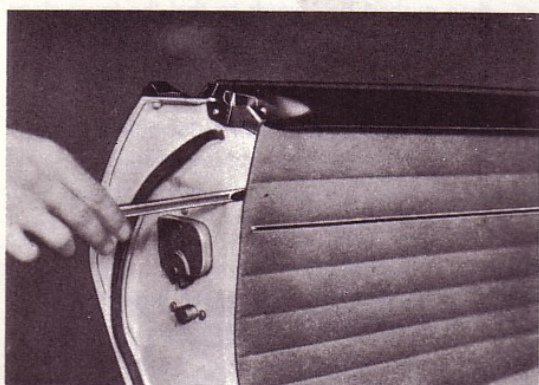


Fig. 9. Removing door upholstery.

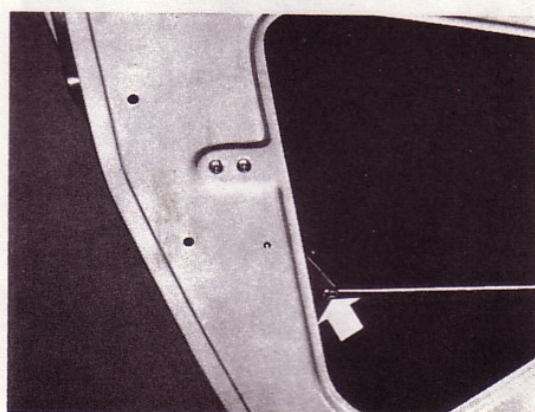


Fig. 12. Clip for lock lever.

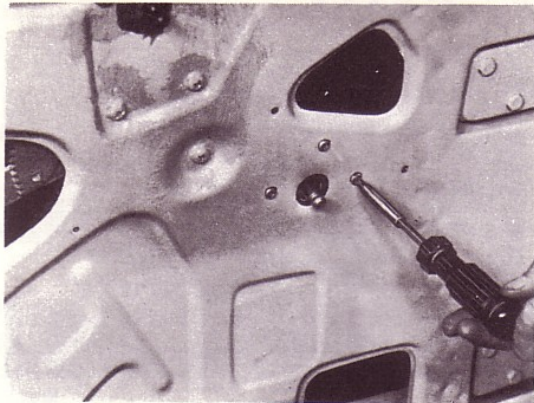


Fig. 13. Removing remote control.

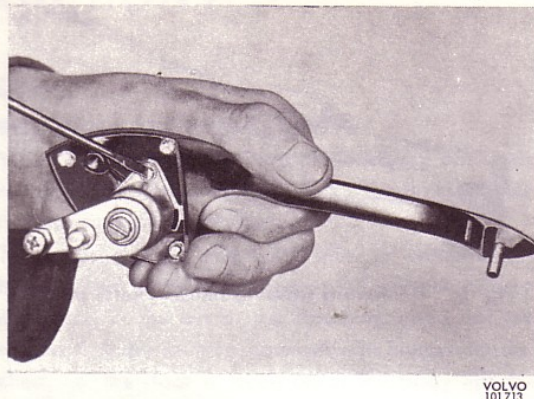


Fig. 15. Dismantling door handle.

## Door locks and door handles

### REMOVING DOOR LOCKS AND OUTER HANDLES

Carry out operations 1—6 under the heading "Removing inner handles and door upholstery".

1. Remove the clip for the lever, see Fig. 12.
2. Unscrew the three screws (Fig. 13) and take out the inner handle mechanism (remote control).
3. Remove the clip for the lever between the lock and outer handle up on the handle.
4. Unscrew the screws in the door edge (Fig. 14) and the screws shown in Fig. 12 for the joint for the lower link arm of the lock.
5. Unscrew the screws for the outer handle and remove the handle.

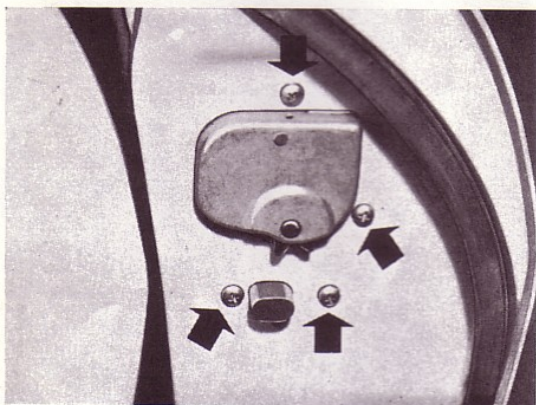


Fig. 14. Attaching screws for door lock.

### DISMANTLING DOOR HANDLES

1. Remove the screw for the sleeve as shown in Fig. 15 and then the screw for the control lever, after which the pressure spring can be taken off. On earlier cars there is a circlip instead of a screw.
2. Remove the circlip, see Fig. 16.
3. The lock plunger can then be dismantled.

### FITTING AND ADJUSTING LOCKS

1. Fit the lock (Fig. 17) with remote control in the door without tightening the screws for the remote control. Fit the lever between the lock and remote control.
2. The remote control with split pin inserted is then pushed backwards so that the lever stops against the lock. The remote control is then tightened up in this position and the split pin removed.

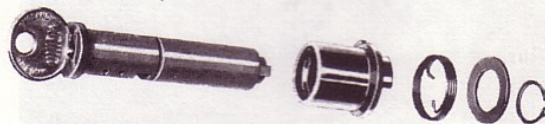


Fig. 16. Press-button in door lock dismantled.

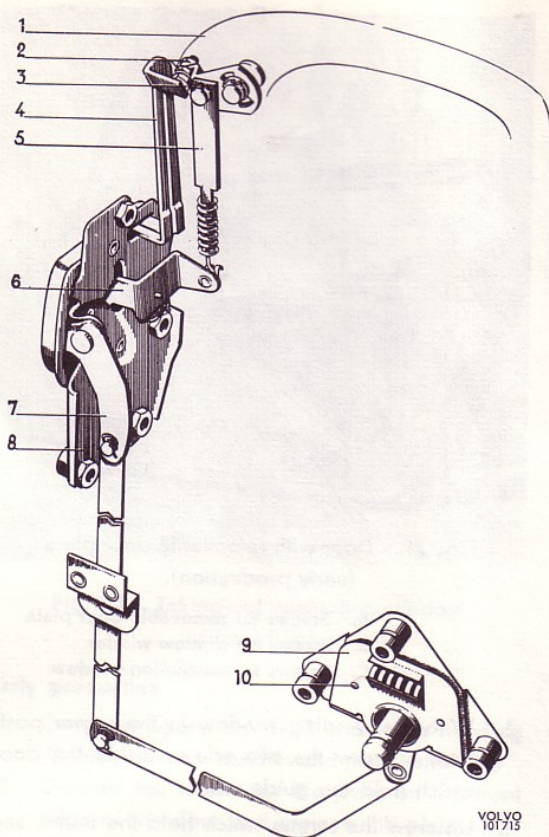


Fig. 17. Door lock with remote control.

- |                    |  |
|--------------------|--|
| 1. Outer handle    | 7. Lever   |
| 2. Lock nut        | 8. Lock  |
| 3. Adjusting screw | 9. Remote control                                    |
| 4. Lever           | 10. Hole for inserting split pin when adjusting lock |
| 5. Link arm        |  |
| 6. Lever           |  |

#### FITTING AND ADJUSTING OUTER HANDLES

##### Late production

1. Fit the outer handle.
2. Check the clearance between the control lever adjusting screw and stop on the lock lever. The clearance should be 1—2 mm (about 1/16"), which is adjusted with the control lever adjusting screw.
3. Fit the link arm (5, Fig. 17) between the control lever and lock. Adjust the length of the link arm by screwing the spring out or in so that the control lever is clear of the stop plate when locked and contacts the middle of the plate when unlocked, see Fig. 17.

##### Early production

1. Fit the outer handle.
2. Check the clearance between the control lever and stop on the lock lever. The clearance should be 1—2 mm (about 1/16"), which is adjusted by bending the lever (4, Fig. 17).
3. Fit the link arm (5) between the control lever and lock. Adjust the length of the link arm by selecting one of the holes in the lower edge. Adjustment should be done so that the control lever is clear of the stop plate when locked and contacts the middle of the plate when unlocked, see Fig. 26.

##### Latch plates

The latch plate (Fig. 18) is made of steel and is fitted with a floating nut plate. The plate is adjustable since the diameter of the holes in the body is larger than the diameter of the attaching screws. The vertical position of the latch plate is checked by closing the door with the press-button of the outer handle pressed in, when the guide pin should slide straight into the latch plate. N.B. This should be done immediately after the latch plate is fitted.

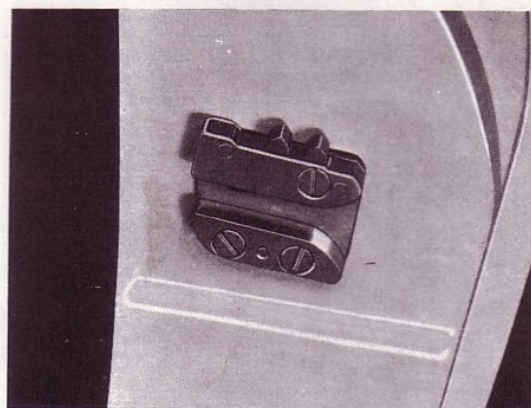


Fig. 18. Latch plate.

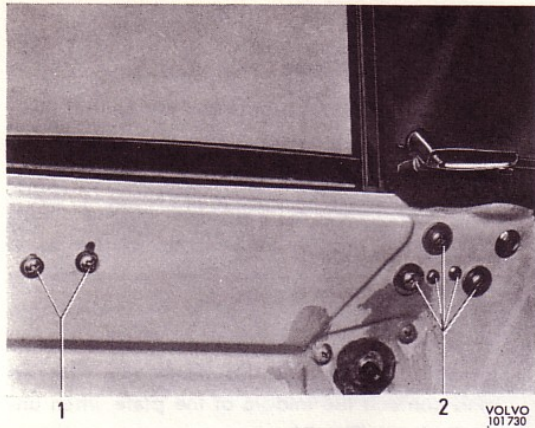


Fig. 19. Attaching screws for ventilation window and winding window stop.

1. Stop for winding window in upper position
2. Attaching screws for ventilation window

### Ventilation windows

#### REMOVING AND FITTING, WITH FRAME

##### Late production

The frame of the ventilation window is combined with one of the guide rails for the winding window. When removing the ventilation window with frame, proceed as follows:

1. Carry out operations 1—5 under the heading "Removing inner handles and door upholstery".
2. Unscrew the six screws for the chromium-plated plate on the front edge of the door and remove the plate.



Fig. 20. Taking out the ventilation window with frame.

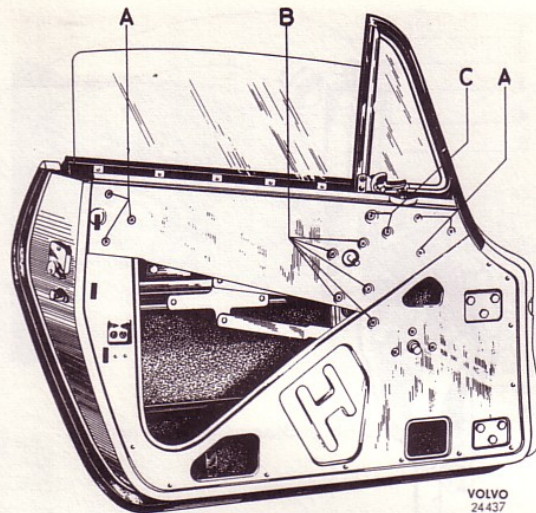


Fig. 21. Door with removable door plate (early production).

- A. Screws for removable door plate
- B. Screws for window winder
- C. Screws for ventilation window

3. With the winding window in the upper position, unscrew the two screws inside the door which hold the guide rail.
4. Unscrew the screws which hold the frame, see Fig. 19.
5. Wind down the window to the bottom position. Then pull the ventilation window straight up and turn it half a turn, when the attachment on the lower part of the guide rail can be removed from the door, see Fig. 20.
6. Fitting is done in the reverse order.

**N.B.** Check that the winding window runs easily in the grooves after fitting.

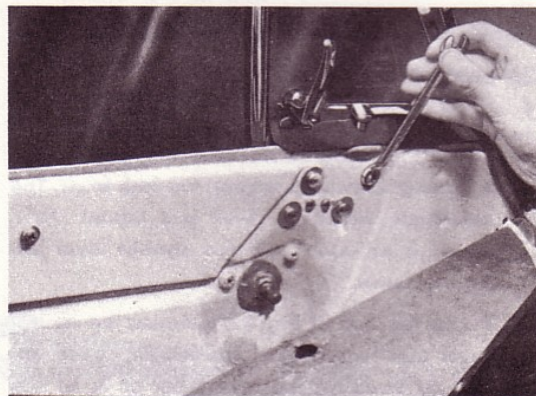


Fig. 22. Removing ventilation window without frame.

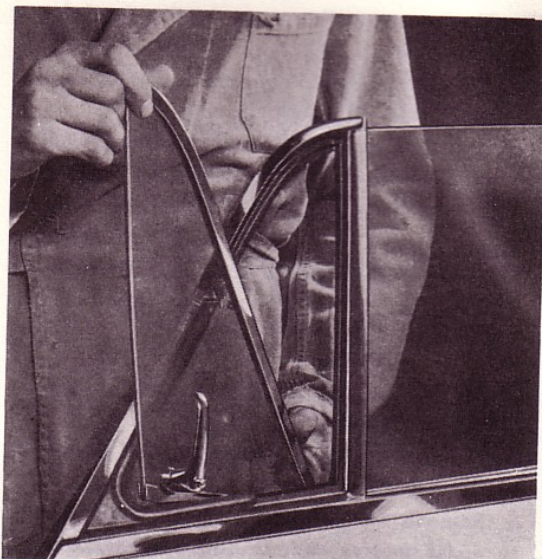


Fig. 23. Taking out ventilation window without frame.

#### Early production

1. Carry out operations 1—3 under the heading "Removing inner handles and door upholstery".
2. Unscrew the screws for the plate on the front edge of the door and remove the plate.
3. Unscrew the two screws (C, Fig. 21), after which the ventilation window with guide rail for winding window can be lifted up.
4. The end of the guide strip rests against a locating catch attached to the door. When fitting, ensure that this catch comes in the correct place on the strip. The catch can also be adjusted.

#### REMOVING AND FITTING, WITHOUT FRAME

##### Late production

1. Carry out operations 1—3 under the heading "Removing inner handles and door upholstery".
2. Remove the plastic material which covers the door and screw out the adjusting pin (Fig. 22) for the ventilation window. When doing this, insert the hand through the large hole in the door and remove the cap on the back of the lower hinge for the ventilation window.
3. Turn the ventilation window fully open and press it downwards so that the upper hinge releases, after which the window can be removed as shown in Fig. 23.
4. When fitting, tighten the adjusting pin until the window moves sufficiently stiffly for opening and closing.

#### Early production

1. When removing the ventilation window on early production cars, carry out operations 1—3 under the heading "Ventilation windows", "Removing and fitting, with frame, early production".
2. Remove the two adjusting screws for the ventilation window.
3. Turn the ventilation window fully open and then press it downwards so that the upper hinge releases, after which the window can be removed.
4. When fitting, tighten the adjusting pin until the window moves sufficiently stiffly for opening and closing.

#### Winding window with winding mechanism

##### REMOVING AND FITTING

Carry out operations 1—5 under the heading "Removing inner handles and door upholstery".

Carry out operations 1—5 under the heading "Ventilation window", "Removing and fitting, with frame".

#### Late production

1. Release the stop for the upper position of the winding window, see Fig. 9.
2. Wind up the window as far as it will go and then lower it about half a turn. N.B. Hold the window when doing this.
3. Move the window backwards and turn it inwards so that it releases from the groove in the winding mechanism, see Fig. 24.
4. Lower the winding mechanism and lift up the window.

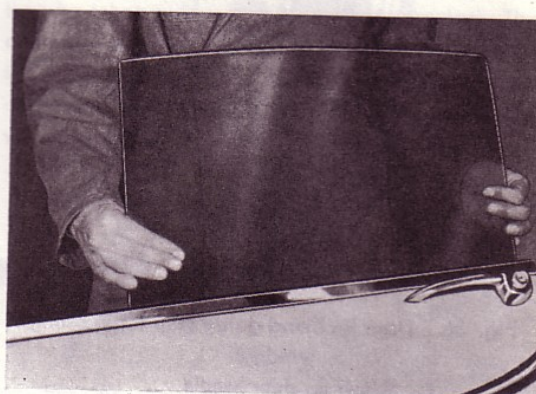


Fig. 24. Taking out the winding window.

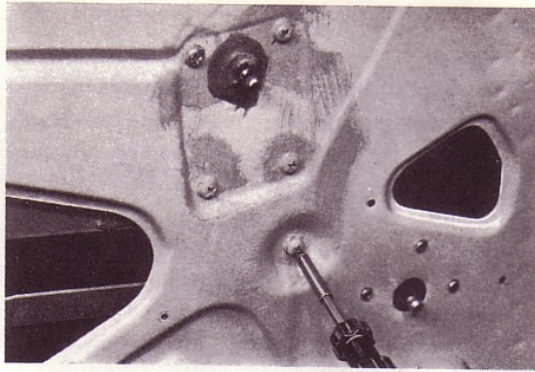


Fig. 25. Removing the winding mechanism.

5. Unscrew the five screws for the winding mechanism, see Fig. 25, and remove the mechanism.
6. When fitting, ensure that the window runs easily in the grooves. The rear guide strip of the winding window can be adjusted to vary the contact between the glass and sealing strip, see Fig. 26.

**Early production**

1. Loosen the upper removable plate where it is attached to the winding window (Fig. 21) and ventilation window.

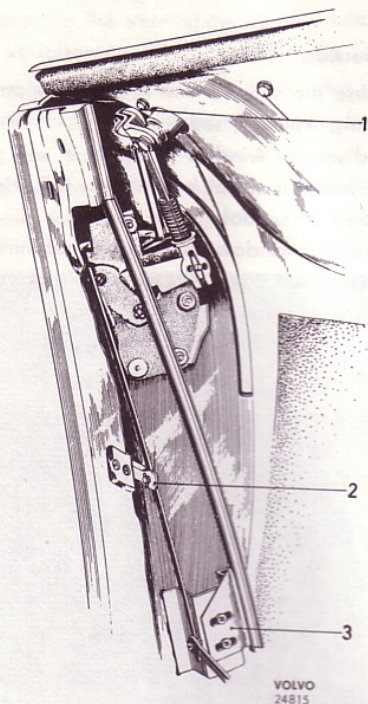


Fig. 26. Door lock and guide strip for winding window.

1. Screws for door handle
2. Mounting
3. Adjusting screws

2. Then unscrew the screw in the fixed lower inner plate on the door.
3. Lift out the winding window and winding mechanism.
4. When fitting, ensure that the winding window runs easily in the grooves. The rear guide strip of the winding window can be adjusted to vary the contact between the glass and sealing strip (Fig. 26). The guide strip can be removed after the upper, outer trim moulding has been taken off.

**Sealing strips  
BONDED STRIPS**

When fitting new rubber strips, proceed as follows:

1. Remove the old strips.
  2. Remove all traces of old adhesive from the metal surfaces with cellulose thinners, petrol or similar. It is most important to carry this out carefully since no residue from old adhesive must be left on the metal, but at the same time care must be taken to make sure that the paintwork is not damaged by the solvent used. (Requirements: Clean rags, wooden putty knife.)
  3. The new rubber strips should be thoroughly cleaned with petrol, methylated spirits or similar. (Requirements: Clean rags, fibre brush.)
  4. After they have dried, the rubber strips should be coated with Dekalin TH (Volvo accessory number: Dekalin TH 277062, Dekalin thinners 279795) or equivalent and then allowed to dry to a non-tacky state, which usually takes about 15 minutes. (Requirements: Thick hair brush.)
  5. The metal surfaces to which the rubber strips are to be attached are then coated with Dekalin TH. (Requirements: Thick hair brush.)
  6. The treated and non-tacky rubber strips are then pressed on to the newly applied adhesive on the metal.
  7. The rubber strips should be pressed firmly against the metal surfaces so that there is no air trapped in the joints.
- N.B.** Wait for at least 15 minutes after the strips have been applied before closing the door.

**STRIPS ATTACHED WITH RAILS**

These sealing strips are fitted in a rail which is spot-welded to the door.

The sealing strip is removed by pulling it outwards, when the fold of the sealing strip releases from the rail.

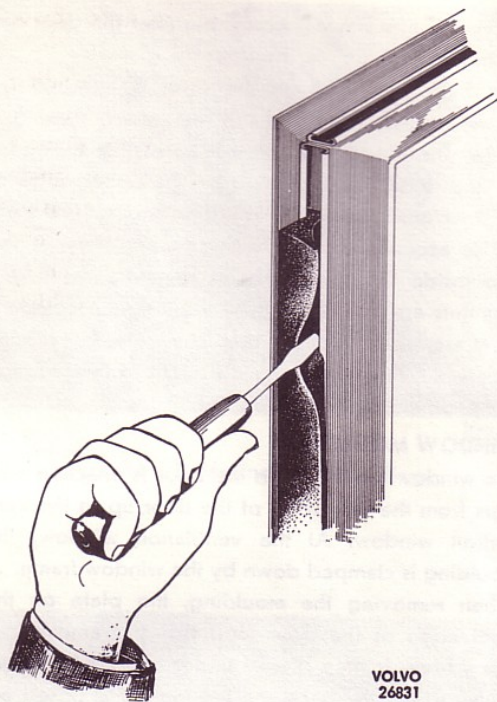


Fig. 27. Fitting sealing strip for door.

When fitting sealing strips, one of the folds is placed in position in the rail, after which the other fold is pressed down into the rail with the help of a screwdriver. The tool is moved along the rail as shown in Fig. 27.

### Luggage compartment lid

The luggage compartment lid is mounted on two hinges, each of which is bolted to the inner plate of the lid with two screws and to the plate below the rear window with four screws, see Fig. 28.

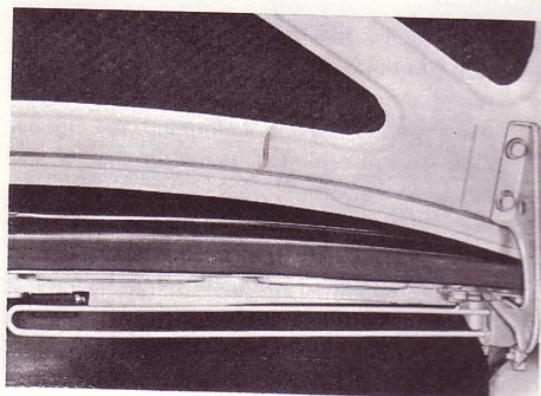


Fig. 28. Hinges for luggage compartment lid.

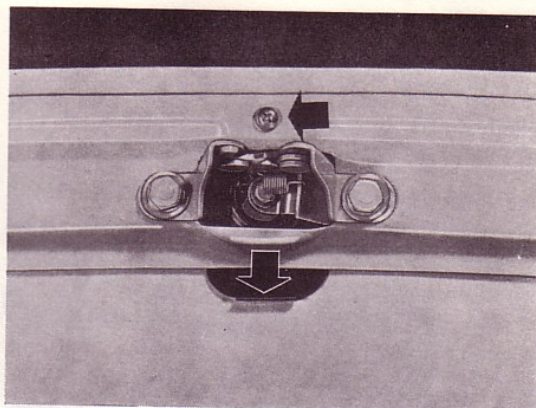


Fig. 29. Lock for luggage compartment lid.

The holes in the part of the hinges attached to the luggage compartment lid are oval, thus permitting longitudinal adjustment. There are floating nut plates in the lid for lateral adjustment.

When removing the hinges, first pull the torsion stay straight out so that it releases from its rubber mounting. After the four screws have been removed, the complete hinge with torsion stay attached can be taken off.

When removing the lock, unscrew the screws on the inside of the upper edge of the lid. The latch plate is then pulled out, after which the lock can be removed, see Fig. 29.

### Dismantling lock for luggage compartment lid

The lock is dismantled by screwing out the screw in the lower part of the lock. The lock plunger can then be taken out by fitting the key in the lock. This can also be done with the lock fitted in position on the luggage compartment lid. When removing the other parts of the lock, take off the circlip, after which all the parts can be taken out, see Fig. 30.

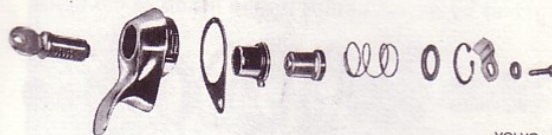
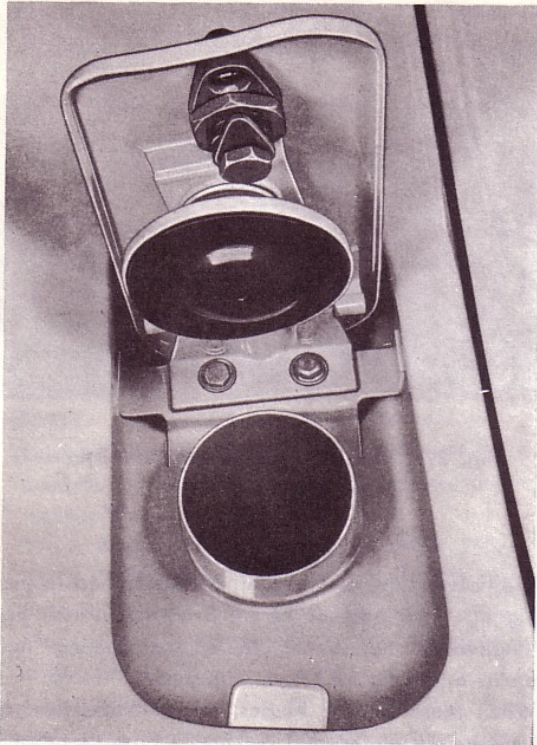


Fig. 30. Lock for luggage compartment lid dismantled.



VOLVO  
101724

Fig. 31. Tank cover with lock.

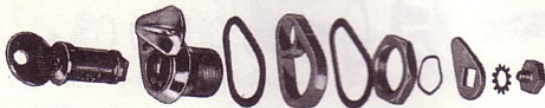
### Removing tank cover and lock

The tank cover is removed by screwing out the two screws for the hinge, after which the tank cover can be taken off, see Fig. 31. The cover can be adjusted laterally and longitudinally since the diameter of the screw holes in the hinge is larger than the diameter of the screws. The cover can be adjusted vertically by placing packing pieces under the hinge.

The lock is removed by unscrewing the screw underneath the lock and taking off the lock latch. The lock plunger can be taken out by fitting the key in the lock and pulling out the plunger. The large nut underneath the lock is then removed, after which the complete lock unit can be removed from the cover, see Fig. 32.

### Trim mouldings WAIST MOULDINGS

The waist mouldings on the front mudguard is attached by means of nuts on the inside of the mud-



VOLVO  
101725

Fig. 32. Lock for tank cover dismantled.

guards. The rear nut is accessible after the door has been opened.

The waist moulding on the door is attached by means of clips except at the rear where there is a screw. The nut for this screw is accessible by opening the door. The moulding on the upper edge of the rear mudguard is attached with nuts. The front nut is accessible after the side upholstery at the rear inside the car has been removed, while the rear nuts are accessible from the luggage compartment. In order for the rear screw to be readily accessible, the side insulating board in the luggage compartment can be taken out.

### WINDOW MOULDINGS

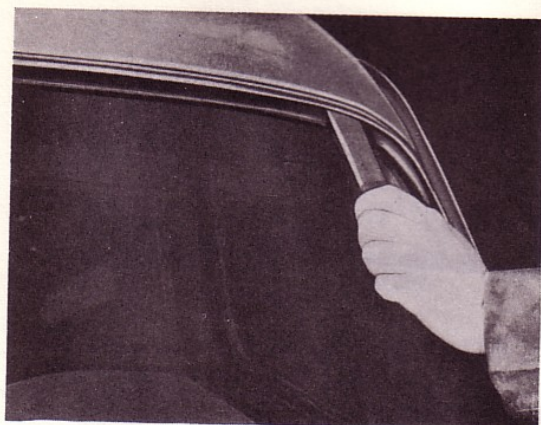
The window moulding on the door is attached with clips from the rear edge of the door up to the ventilation window. At the ventilation window, the moulding is clamped down by the window frame.

When removing the moulding, the plate on the front edge of the door must first be removed. A screwdriver is then placed under the moulding beginning from the back and the moulding prised out slightly up to the ventilation window. N.B. Use masking tape or similar under the screwdriver when prising out the moulding in order not to damage the paintwork. When this has been done, the moulding can be removed by pulling the front edge of the ventilation window inwards, after which the moulding can be pulled up.

In order to remove the window moulding under the rear quarter light, the window must first be removed must first be removed, see under the heading "Rear quarter light". After this, the moulding can be removed by unscrewing the self-tapping retaining screws.

### Trim mouldings, windscreen and rear window REMOVING

1. Remove the trim moulding from the rubber strip (do not pull off the trim moulding) by inserting a moistened nylon putty knife between the strips and working it all round, see Fig. 33.
2. Slide over the joining pieces to one of the moulding halves.
3. Remove the trim moulding by releasing the fold of the rubber strip from the trim moulding with a moistened wooden putty knife and releasing the trim moulding in the middle with another putty knife as shown in Fig. 34. Then prise out the moulding carefully while removing the rubber strip with the other putty knife, see Fig. 35.



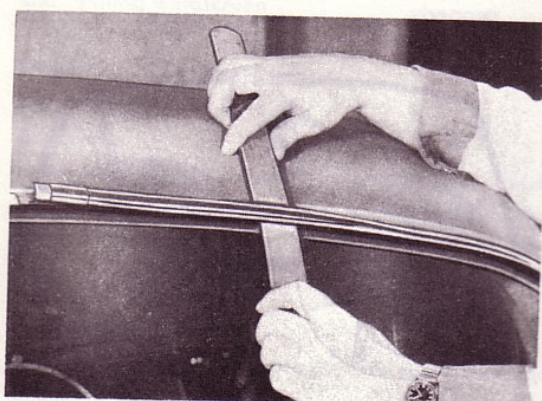
VOLVO  
100 969

Fig. 33. Releasing trim moulding.



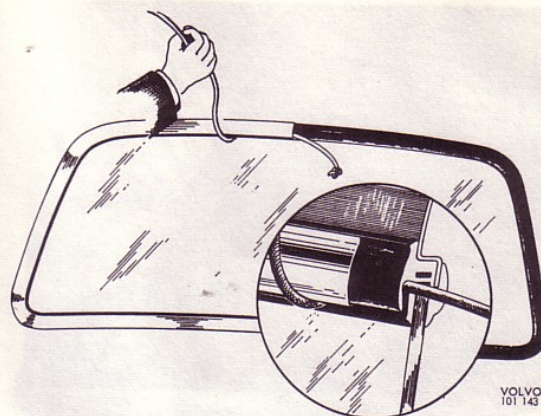
VOLVO  
100 968

Fig. 34. Removing trim moulding from rubber strip.



VOLVO  
100 964

Fig. 35. Removing trim moulding.



VOLVO  
101 143

Fig. 36. Fitting trim moulding.

### FITTING

Place a leather cord (4.0 mm = 5/32"), moistened in soap solution or paraffin, in the groove in the rubber strip for the trim moulding. Place one of the trim moulding halves in position and press it in place while pulling the leather cord upwards over the moulding so that it presses against the rubber strip, see Fig. 36. Slide over the joining pieces and repeat the procedure with the other half of the moulding. Adjust the position of the joining pieces over the joints.

### Windows

#### REMOVING WINDSCREEN

1. Place protective padding over the bonnet, front seats and backrests. Remove the windscreen wiper arms.
2. Remove the trim mouldings as described in points 1—3 under the heading "Trim mouldings, windscreen and rear window", Removing".



VOLVO  
100 967

Fig. 37. Releasing rubber strip.

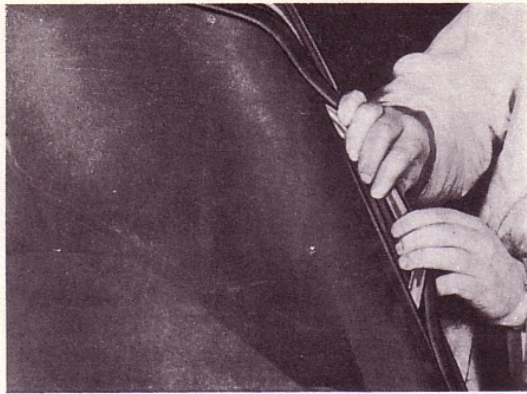


Fig. 38. Removing rubber strip.

3. Release the rubber strip both from the windscreen and sheet metal by inserting and working round a wooden putty knife moistened in synthetic washing solution between the rubber strip and windscreen and between the rubber strip and sheet metal respectively (the putty knife should be moistened now and then during the course of the work).
4. Start removing the rubber strip at the upper left-hand corner by prising it over the sheet metal edge from inside and at the same time carefully pulling out the strip from outside with a pair of wide-jawed grips as shown in Fig. 37. Then carefully pull off the strip by hand all round as shown in Fig. 38 and remove the windscreen.

Remove all sealing compound from the sheet metal. If it has dried on, first carefully scrape off the sealing compound and then wash clean with white spirit. Check that the sheet metal edge is not deformed. If the sealing compound has not dried on the rubber strip, also clean this with white spirit. Otherwise use new rubber strips.

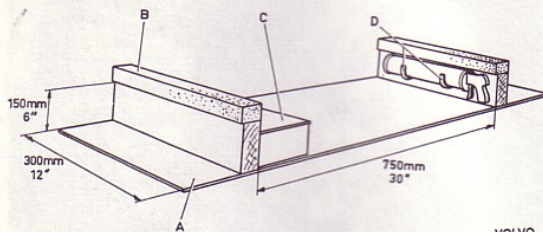


Fig. 39. Stand for windscreen when fitting rubber strip.

- |  |   |
|--|---|
| A. Plywood sheet,<br>15 mm ( $\frac{19}{32}$ "") | C. Storage compartment                      |
| B. Foam plastic, 1—1½"                           | D. Hooks for sealing<br>compound applicator |

8—14

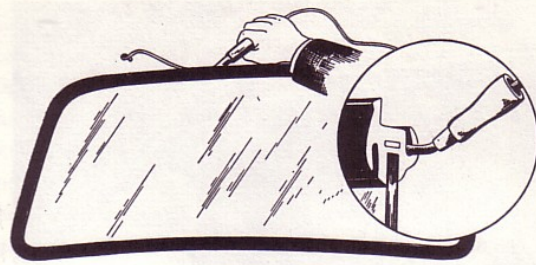


Fig. 40. Placing cord in rubber strip.

#### FITTING WINDSCREEN

1. Place the windscreen on a stand as shown in Fig. 39. Moisten the outer edge of the windscreen and fit the rubber strip starting at one of the corners. Adjust the strip so that it lies correctly all round.
2. Fit a cord (preferably terylene, 5 mm =  $\frac{3}{16}$ "") in the groove of the rubber strip for the sheet metal edge, beginning at the top centre as shown in Fig. 40.
3. Place the windscreen in position with rubber strips fitted. Wearing working gloves, carefully strike the windscreen a few blows with the palm of the hand so that it makes good contact all round. Then carefully pull out the cord from inside. This will cause the rubber strip to "creep" over the sheet metal edge as shown in Fig. 41. It may sometimes be necessary to adjust the position of the windscreen with the palm of the hand. If the cord is difficult to pull out, this may cause damage to the strip, in which case the windscreen should be struck with the palm of the hand either from inside or outside as necessary if the rubber strip does not "creep" over the edge of the sheet metal properly.

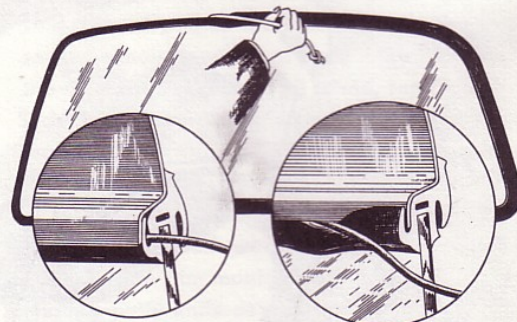


Fig. 41. Fitting windscreen.

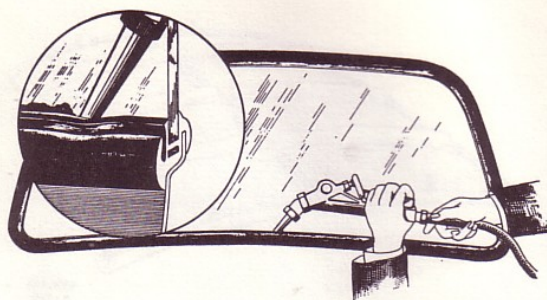
VOLVO  
24813

Fig. 42. Applying sealing compound.

4. Check that the rubber strip seals well all round. If necessary, adjust the position of the windscreen both vertically and laterally by striking with the palm of the hand.
5. Seal the joints between the rubber strip-windscreen and rubber strip-sheet metal with sealing compound using an applicator with a flat nylon nozzle as shown in Fig. 42. Make sure that the sealing compound fills the joint well. Scrape off surplus sealing compound and wash the windscreen and sheet metal with white spirit. Clean the windscreen and sheet metal around it with suitable polish.
6. Fit the windscreen wiper arms.

## Rear window

### REMOVING AND FITTING

See under the headings "Removing windscreen" and "Fitting windscreen".

## Rear quarter light

### REMOVING AND FITTING

See under the headings "Removing windscreen" and "Fitting windscreen".

## Seats

### FRONT SEATS

#### Removing

Release the press fasteners which hold the squab to the frame and remove the squab. Unscrew the four attaching screws for the slide rails. Lift off the seat.

#### Adjusting

The seat is adjusted vertically by means of the attaching nuts (3, Fig. 43). The lumbar support is adjusted with the screw (2), which can be turned with a Phillips screwdriver.



Fig. 43. Front seat, late production.

1. Handwheel for adjusting backrest inclination
2. Adjustment for lumbar support
3. Attachments for vertical adjustment
4. Catch for longitudinal adjustment

The backrest inclination is variably adjustable with the handwheel (1).

In order to adjust the seat longitudinally, the lever (4) is moved to one side.

### REAR SEAT

#### Removing backrest

1. Lift out the squab and hinge down the backrest.
2. Unscrew the screws (Fig. 44).
3. Lift out the backrest, when the upholstery over the hat shelf also comes off with it.

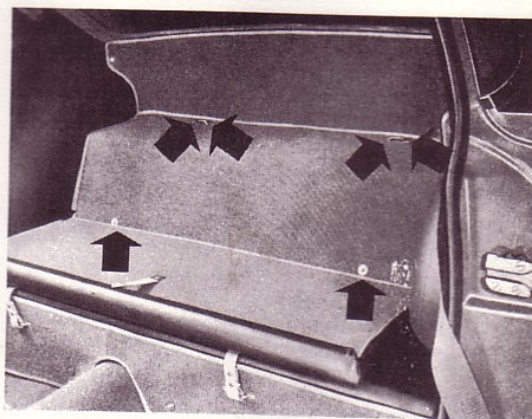
VOLVO  
101726

Fig. 44. Attaching screws for rear seat backrest with hat shelf.

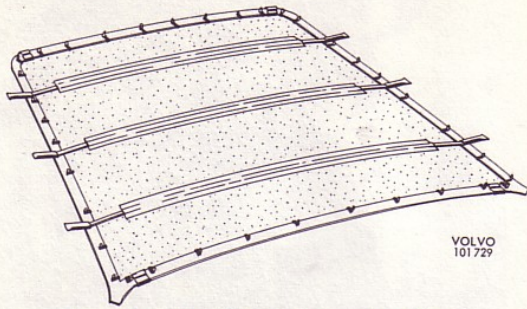


Fig. 45. Headlining, late production.

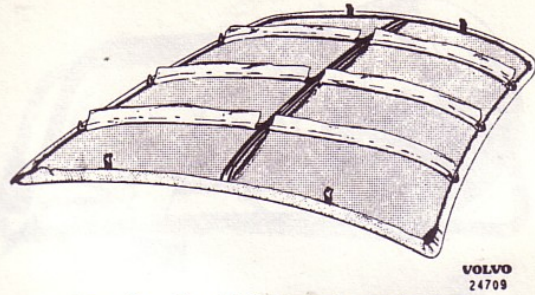


Fig. 46. Headlining, early production.

## Upholstery

### REPLACING HEADLINING

On late production models, the headlining is fitted on a wood-fibre frame. The frame is provided with ribs which keep the headlining stretched. When removing, take off the retainer for the sun visors and then prise round the edge with a suitable tool to release the clips, after which the frame can be taken down.

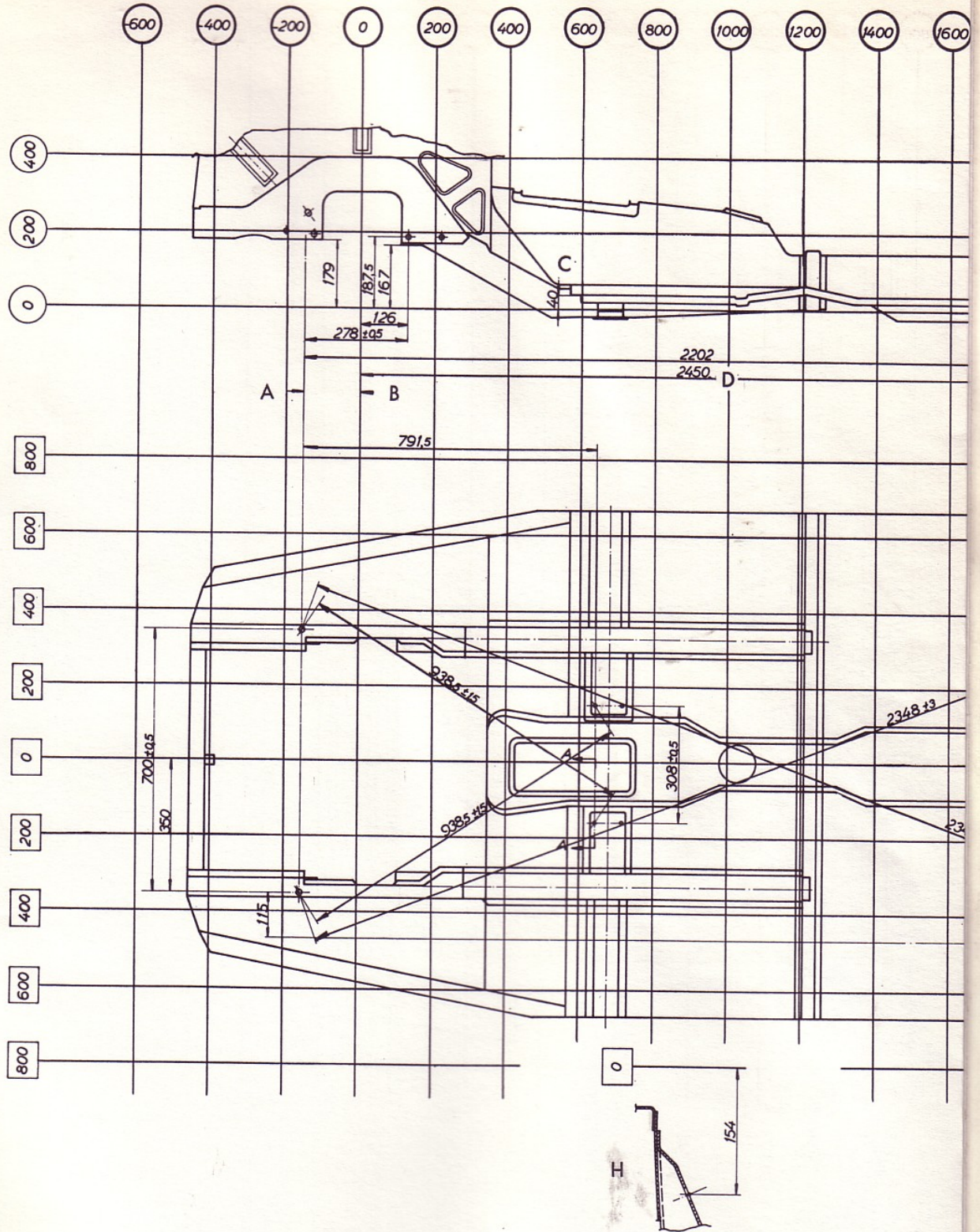
On early production models the headlining, Fig. 46, is stretched over a ribbed frame and attached with four screws and clips. When removing, first take off the interior lights and sun visors, after which the two screws under the sun visor attachments are

removed. Then carefully remove the side upholstery at the interior lights, after which the two rear screws are accessible. Then carefully prise out the frame with the help of a suitable tool.

### Instrument panel

#### REMOVING INSTRUMENT PANEL

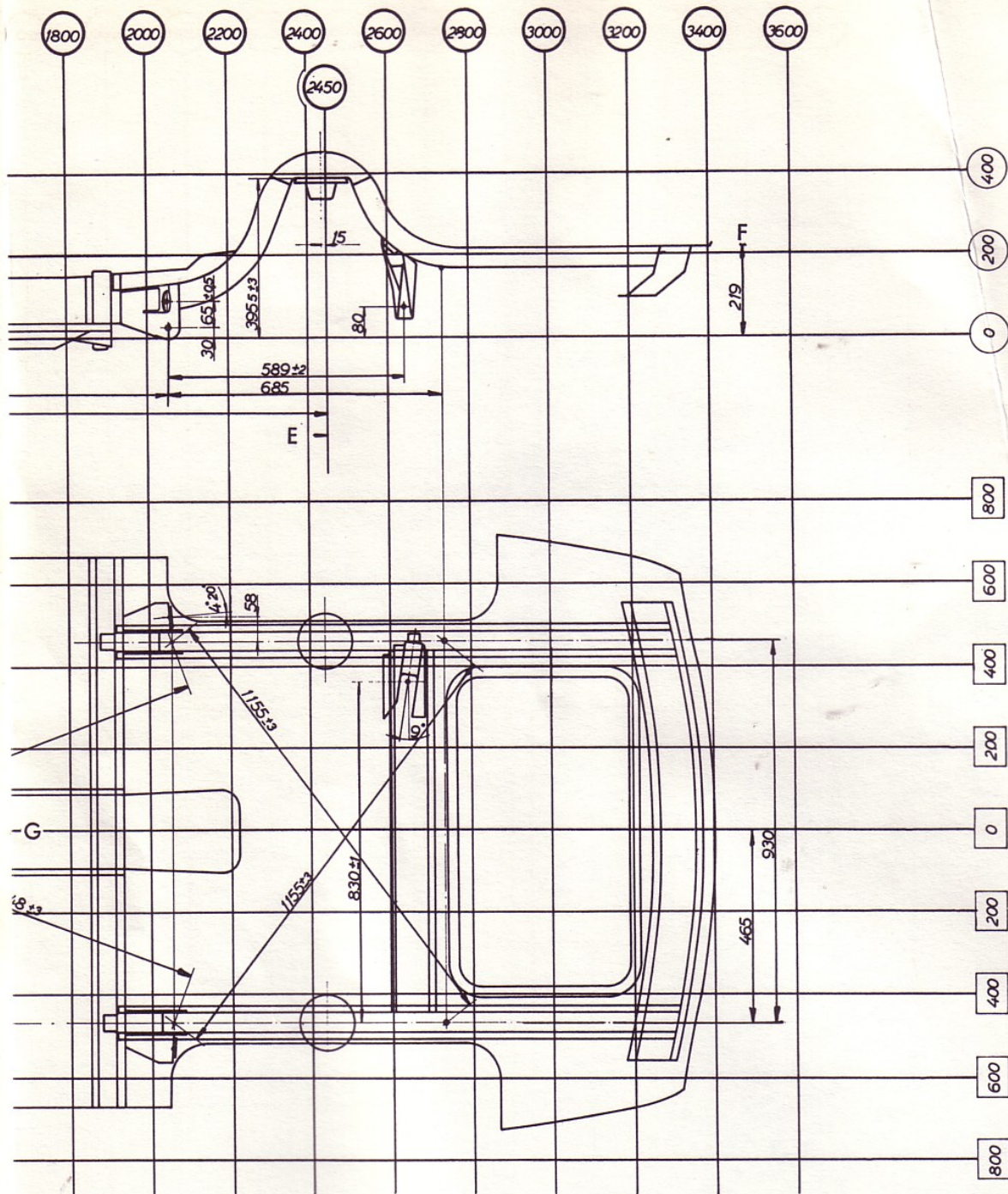
The instrument panel is attached to the body with screws. The screws are accessible from underneath on either side and at the lower edge of the wind-screen.



15 mm	= 0.59"
30 mm	= 1.18"
40 mm	= 1.58"
58 mm	= 2.28"
65 ± 0,5 mm	= 2.56 ± 0.02"
80 mm	= 3.15"
115 mm	= 4.58"
126 mm	= 4.96"
154 mm	= 6.06"
167 mm	= 6.58"
179 mm	= 7.05"
187,5 mm	= 7.38"
219 mm	= 8.62"
278 ± 0,5 mm	= 10.95 ± 0.02"
308 ± 0,5 mm	= 12.13 ± 0.02"

Plate A. Control drawing for body floor P

- A = Front attachment for front axle
- B = Centre line of front axle
- C = Underside of floor at car
- D = Wheelbase
- E = Centre line of rear axle
- F = Underside of floor
- G = Centre line of car
- H = Section A—A. Scale 1



VOLVO  
101 728

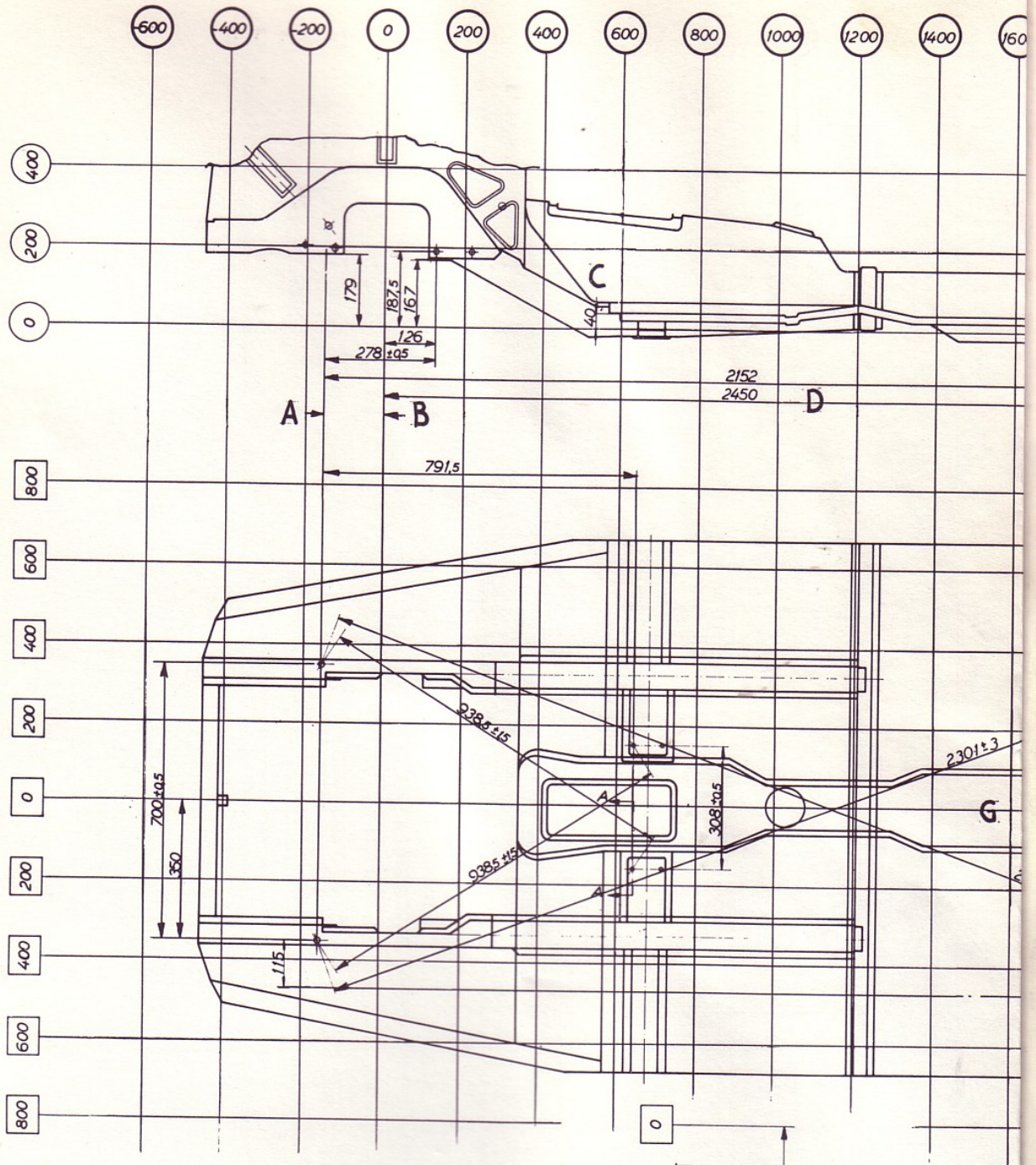
1800 up to chassis No. 16499.

Member

Trail

1

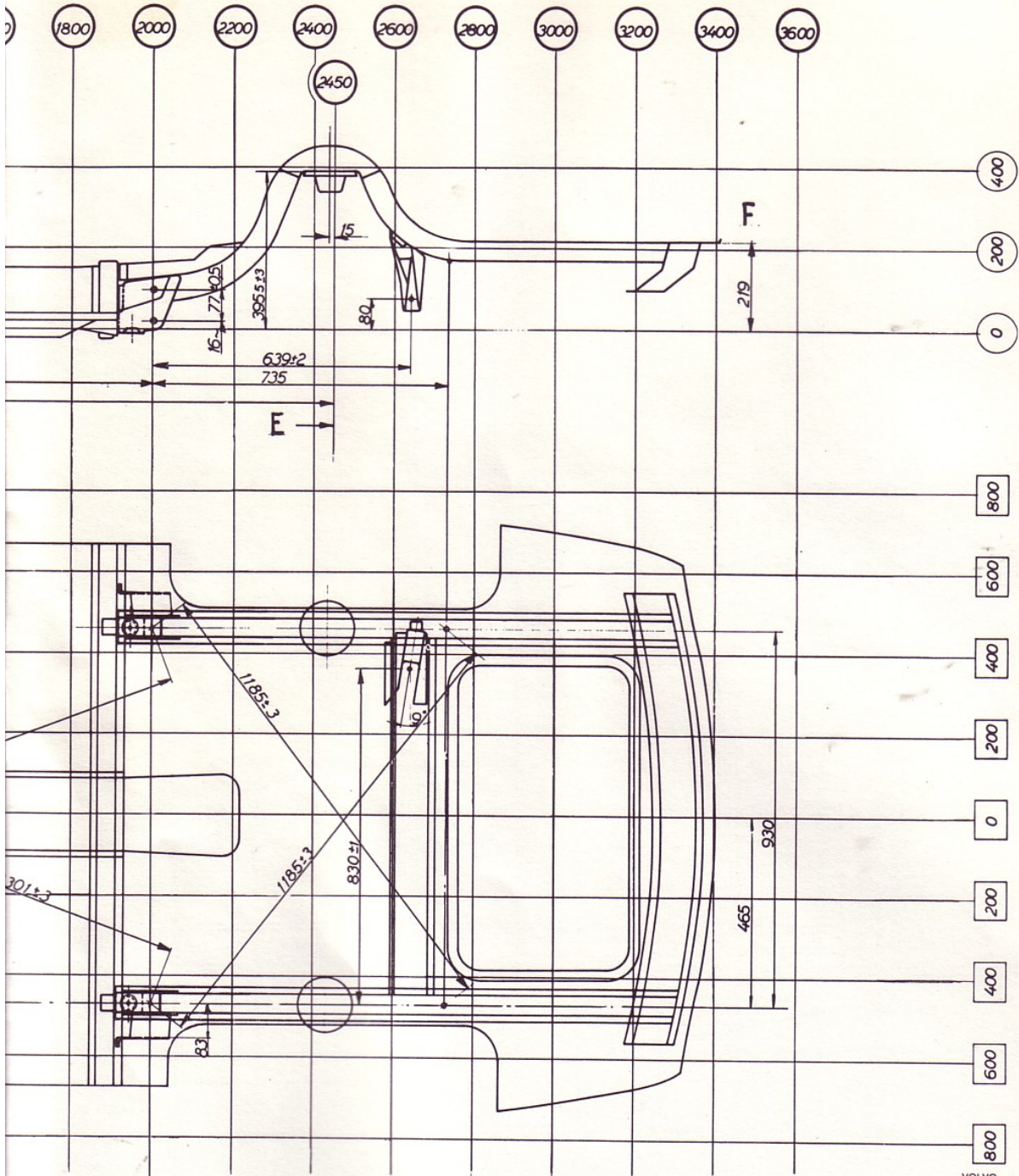
350 mm	= 13.78"
395,5 ± 3 mm	= 15.57 ± 0.12"
465 mm	= 18.31"
589 ± 2 mm	= 23.19 ± 0.08"
685 mm	= 26.97"
700 ± 0,5 mm	= 27.56 ± 0.02"
791,5 mm	= 31.16"
830 ± 1 mm	= 32.68 ± 0.04"
930 mm	= 36.61"
938,5 ± 1,5 mm	= 36.95 ± 0.06"
1155 ± 3 mm	= 45.47 ± 0.12"
2202 mm	= 86.69"
2348 ± 3 mm	= 92.44 ± 0.12"
2450 mm	= 96.46"



15 mm	= 0.59"
16 mm	= 0.63"
40 mm	= 1.578"
77 ± 0,5 mm	= 3.031" ± 0.02"
80 mm	= 3.15"
83 mm	= 3.265"
115 mm	= 4.58"
126 mm	= 4.96"
154 mm	= 6.06"
167 mm	= 6.58"
179 mm	= 7.05"
187,5 mm	= 7.38"
219 mm	= 8.62"
278 ± 0,5 mm	= 10.95 ± 0.02"
308 ± 0,5 mm	= 12.13 ± 0.02"

Plate B. Control drawing for body floor P 18

- A=Front attachment for
- B=Centre line of front
- C=Underside of floor a
- D=Wheelbase
- E=Centre line of rear a
- F=Underside of floor
- G=Centre line of car
- H=Section A—A. Scale



00 with effect from chassis No. 16500.

front member  
 axle  
 cantrail

cle

1:1

350 mm	= 13.78"
395,5 ± 3 mm	= 15.57 ± 0.12"
465 mm	= 18.31"
639 ± 2 mm	= 25.14 ± 0.08"
700 ± 0,5 mm	= 27.56 ± 0.02"
735 mm	= 28.921"
791,5 mm	= 31.16"
830 ± 1 mm	= 32.68 ± 0.04"
930 mm	= 36.61"
938,5 ± 1,5 mm	= 36.95 ± 0.06"
1185 ± 3 mm	= 47.625 ± 0.12"
2152 mm	= 84.724"
2301 ± 3 mm	= 90.584 ± 0.12"
2450 mm	= 96.46"

# Notes

A series of horizontal dotted lines for writing notes, spanning the width of the page.



Printed in Sweden, Gotab, Surte 70.5157