

SERVICE MANUAL

CARS AND VANS

PV 444—445

Part 10

ELECTRICAL SYSTEM

Export Service Department

AKTIEBOLAGET

VOLVO

GÖTEBORG . SWEDEN

DESCRIPTION

PV 444—445 has a 6-volt electrical system. The system may be suitably divided into battery, dynamo, charging relay, starting motor, instruments, lighting and indicator devices as well as the necessary cables.

The battery is mounted on a shelf on the centre of the mounting board. It is a lead battery

consisting of three cells and has a capacity of 85 amp. hours.

The dynamo is located on the right-hand side of the engine and is driven from the crankshaft by means of a pulley belt. It is a shunt-type dynamo, i.e. the field windings are connected in parallel with the armature. Charging is regulated by means of the charging relay.

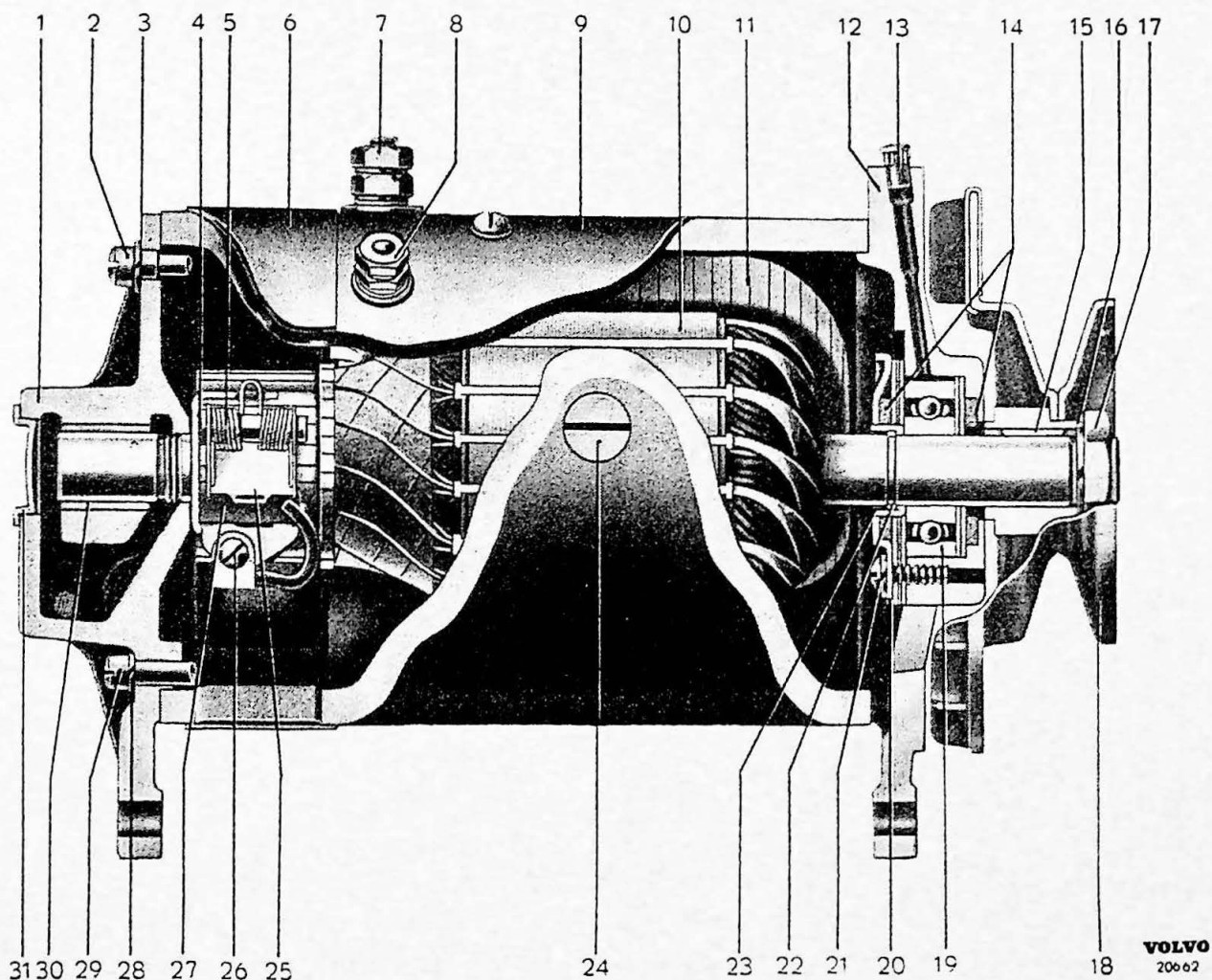

Fig. 1. Dynamo (Auto-Lite).

- | | | |
|-----------------------|------------------------------|---------------------|
| 1. Rear head assembly | 12. Front head assembly | 22. Retainer ring |
| 2. Screw | 13. Front lubricator | 23. Sleeve |
| 3. Spring washer | 14. Seals | 24. Pole shoe screw |
| 4. Brush holder | 15. Woodruff key | 25. Brush arm |
| 5. Spring | 16. Spring washer | 26. Screw |
| 6. Cover band | 17. Nut | 27. Brush |
| 7. Armature terminal | 18. Drive pulley | 28. Spring washer |
| 8. Field terminal | 19. Ball bearing | 29. Screw |
| 9. Housing | 20. Cover | 30. Bushing |
| 10. Armature | 21. Screw with spring washer | 31. End cover |
| 11. Field coil | | |

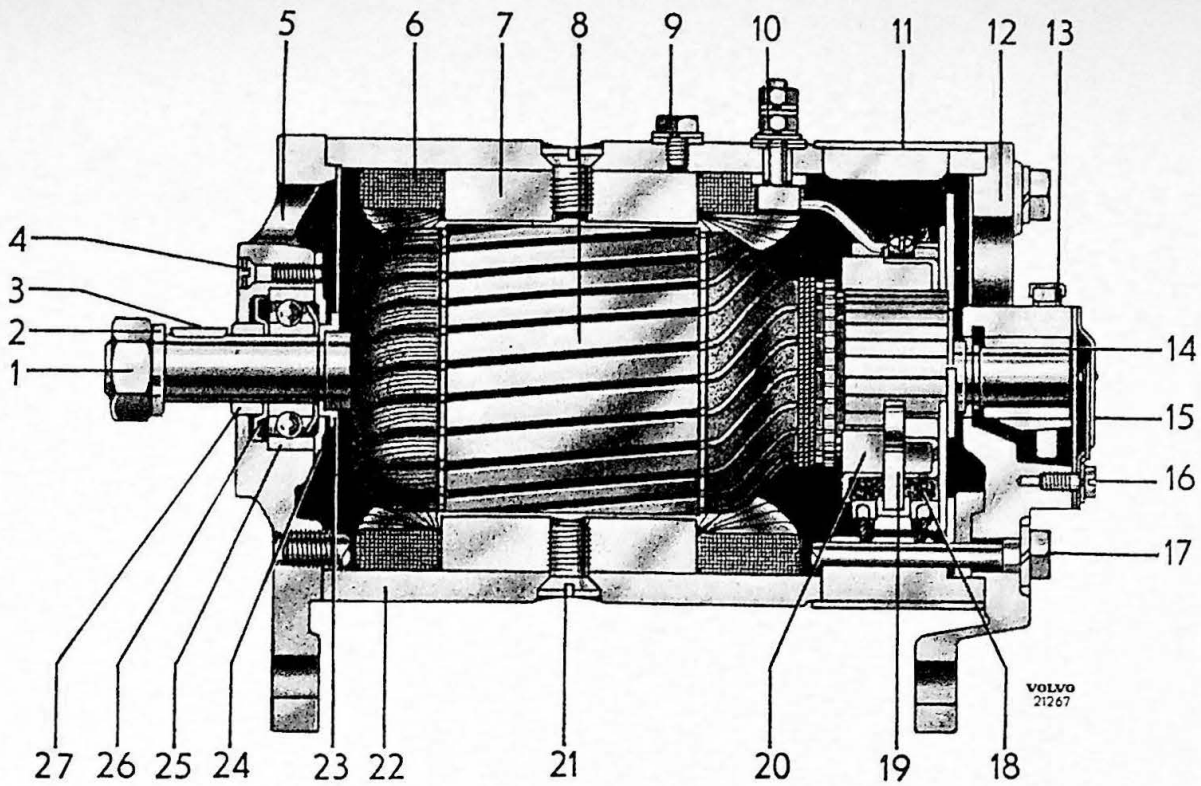

Fig. 2. Dynamo (Bosch).

- | | | |
|-------------------------|------------------------|-----------------------------|
| 1. Nut | 10. Armature terminal | 19. Brush spring |
| 2. Spring washer | 11. Cover band | 20. Brush holder |
| 3. Woodruff key | 12. Rear head assembly | 21. Pole shoe screw |
| 4. Screw | 13. Lubricator | 22. Dynamo housing |
| 5. Front head assembly | 14. Bushing | 23. Washer |
| 6. Field coil | 15. End cover | 24. Protector washer, inner |
| 7. Pole shoe | 16. End cover screw | 25. Ball bearing |
| 8. Armature | 17. Screw | 26. Protector washer, outer |
| 9. Earthing cable screw | 18. Brush | 27. Spacer ring |

Fig. 4. Starting motor (illustration on Page 3).

- | | | |
|-----------------------------|----------------------------|-------------------|
| 1. Screw with spring washer | 14. Spring retainer, inner | 27. Lock screw |
| 2. Rear head assembly | 15. Bendix spring | 28. Guide pin |
| 3. Housing | 16. Spring retainer, outer | 29. Lock ring |
| 4. Cover band | 17. Pinion housing | 30. Screw |
| 5. Pole screw | 18. Lock ring | 31. Pole screw |
| 6. Connector | 19. Return spring | 32. Field coil |
| 7. Starting relay | 20. Meshing spring | 33. Brush holder |
| 8. Pole screw | 21. Rushing | 34. Spring |
| 9. Dust cover | 22. Armature shaft | 35. Brush |
| 10. Armature | 23. Pinion | 36. Washer |
| 11. Spacer | 24. Shaft | 37. Thrust washer |
| 12. Thrust washer | 25. Sleeve | 38. Bushing |
| 13. Bearing | 26. Drive ring | |

The charging relay is fitted on the right-hand side of the front on the mounting board. It is connected to the dynamo and the battery by means of cables. The charging relay functions on the constant voltage control principle. Apart from the voltage regulator there is also a current regulator and a cut-out relay.

The starting motor consists of a four-pole series motor. There are two types. The earlier type is fitted with a Bendix drive, the starting circuit being completed by means of a relay. The later type is fitted with an over-running clutch which is operated by a solenoid starter switch which also connects the starting current.

Dynamo, relay and starting motor circuits are shown in fig. 7.

For more information about dynamo, relay and starting motor see PV—10.

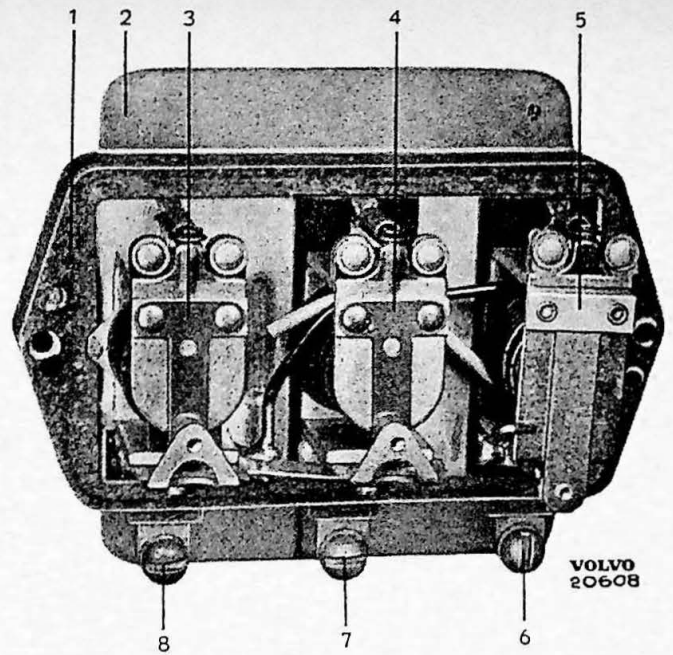

VOLVO
20608

Fig. 3. Charging relay (Auto-Lite).

- | | |
|----------------------|----------------------|
| 1. Cork gasket | 5. Cut-out relay |
| 2. Relay body | 6. Battery terminal |
| 3. Voltage regulator | 7. Field terminal |
| 4. Current regulator | 8. Armature terminal |

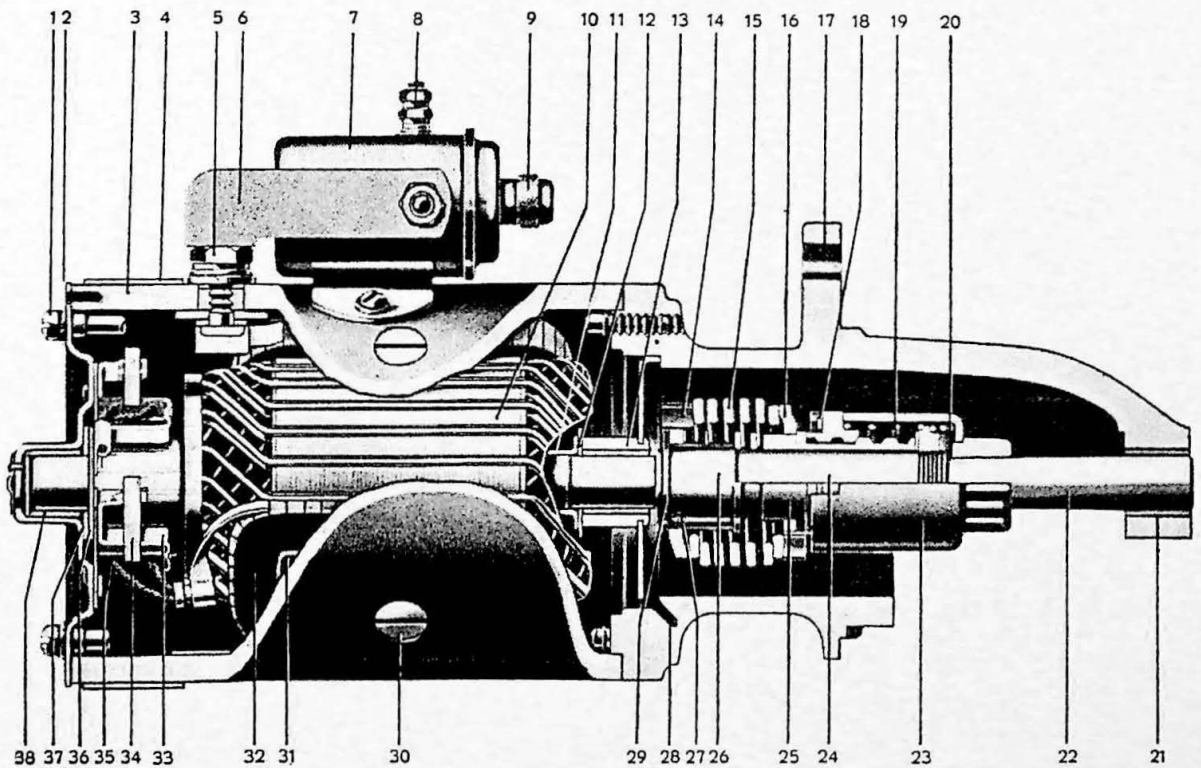

VOLVO
20610

Fig. 4. Starting motor (Auto-Lite with starting relay and Bendix drive).

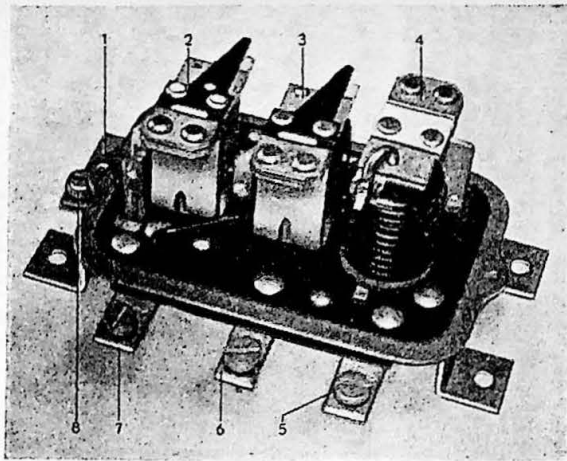

- 1. Relay body
- 2. Voltage regulator
- 3. Current regulator
- 4. Cut-out relay
- 5. Battery terminal
- 6. Field terminal
- 7. Armature terminal
- 8. Earth cable terminal

Fig. 5. Regulator relay (Bosch).

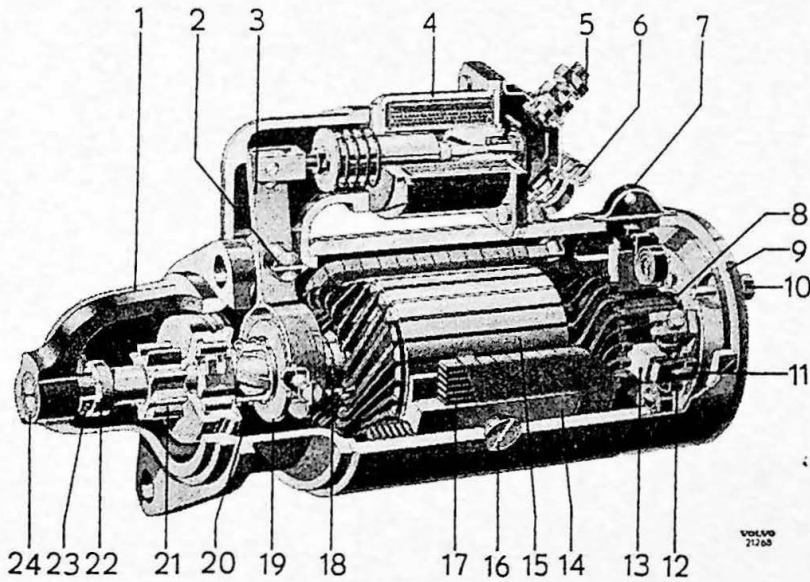

Fig. 6. Starting motor (Bosch with solenoid starter switch).

- | | | |
|----------------------------------|------------------------|-----------------------|
| 1. Rear head assembly | 9. Front head assembly | 17. Field coil |
| 2. Coupling lever screw | 10. Screw | 18. Guide ring spring |
| 3. Coupling lever | 11. Brush | 19. Guide rings |
| 4. Solenoid starter switch | 12. Brush spring | 20. Guide ring spring |
| 6. Terminal screw | 13. Brush holder | 21. Drive and clutch |
| 6. Connector cable to field coil | 14. Pole shoe | 22. Crown nut |
| 7. Cover band | 15. Armature | 23. Cotter pin |
| 8. Armature brake | 16. Pole shoe screw | 24. Bushing |

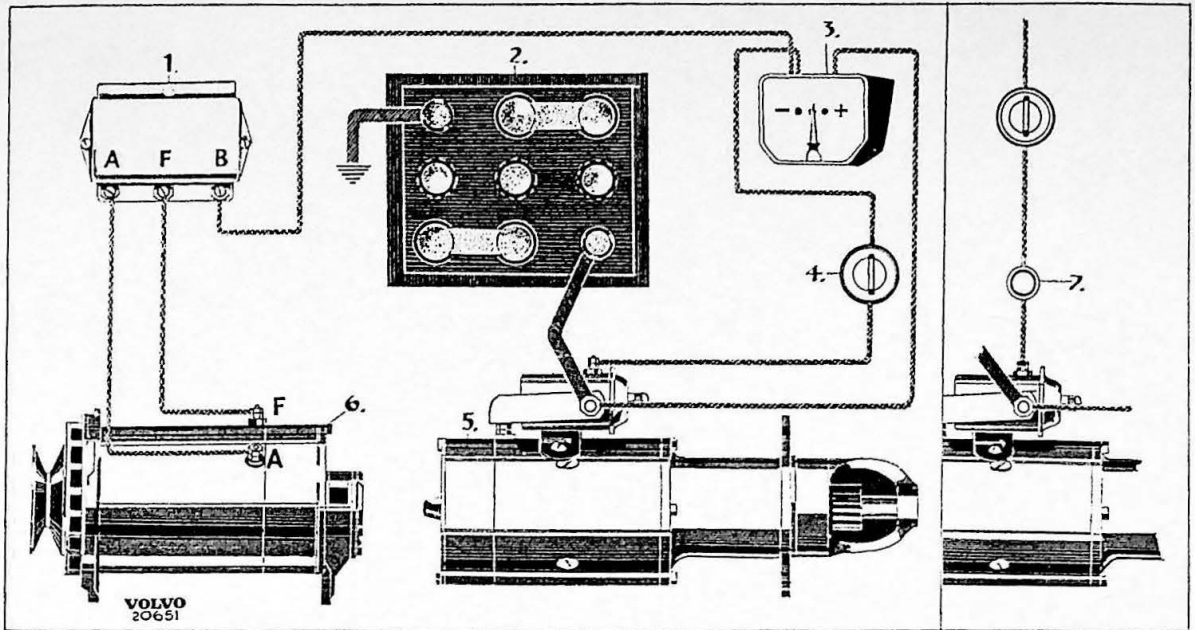

Fig. 7. Circuit diagram.

- | | |
|-------------------|--|
| 1. Charging relay | 5. Starting motor |
| 2. Battery | 6. Dynamo |
| 3. Ammeter | 7. Starting button on PV 444 A
and PV 445 A |
| 4. Ignition key | |

The ammeter is fitted on the left-hand side of the instrument panel. It is connected between the charging relay and the battery. The ammeter shows the degree of charge or discharge of the battery at any given time.

The fuel gauge shows the level of the petrol in the fuel tank. It is fitted on the right-hand side of the instrument panel and is operated by a fuel gauge tank unit.

The headlights are mounted in the mudguards and are held in place by means of screws. The headlight units are fitted in holders with mounting rings. The mounting rings are held in place by means of four springs and two screws. These screws also function as adjustment screws for headlight beam alignment.

The traffic indicators consist of two main types.

The earlier production consists of trafficators

on each side of the car which light up yellow or red.

Later production traffic indicators are of the blinker type. There are two models, one mounted on the roof and the other on the side of the car. They are operated by an automatic blinking device which is fitted under the instrument panel. The control device is a short arm on the steering column below the steering wheel which operates the switch through a lever.

Horns are of two types. PV 444 and PV 445 are fitted with one horn while PV 444 S is fitted with two, one high note and one low note. Cars with double horns are fitted with a relay for battery connection.

Fuses consist of wire fitted on short porcelain bodies. The wires melt when the current exceeds the stipulated level. Fuses of 8 and 25 amps. are fitted to PV 444—445. The fuses are contained in a fuse-box on the mounting panel under the bonnet.

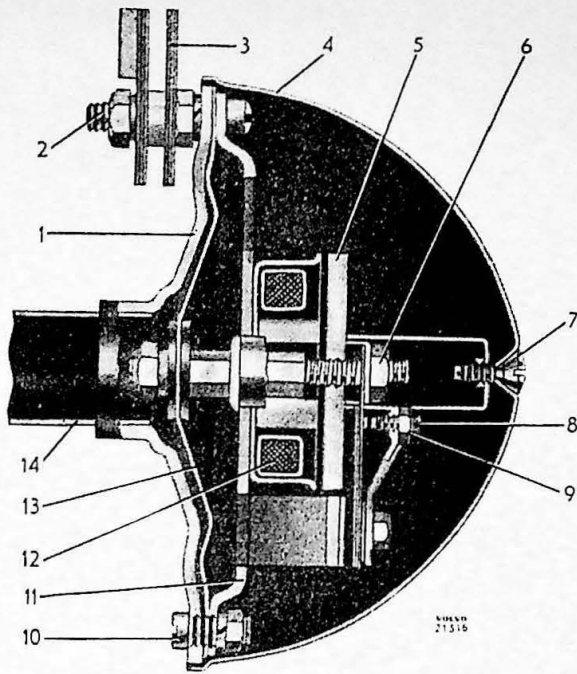

- 1. Cover
- 2. Screw
- 3. Attachment springs
- 4. Housing
- 5. Armature
- 6. Armature lock nut
- 7. Housing screw
- 8. Circuit breaker adjusting screw
- 9. Lock nut
- 10. Screw
- 11. Armature retainer
- 12. Winding
- 13. Diaphragm
- 14. Sound projector

Fig. 8. Horn (Auto-Lite).

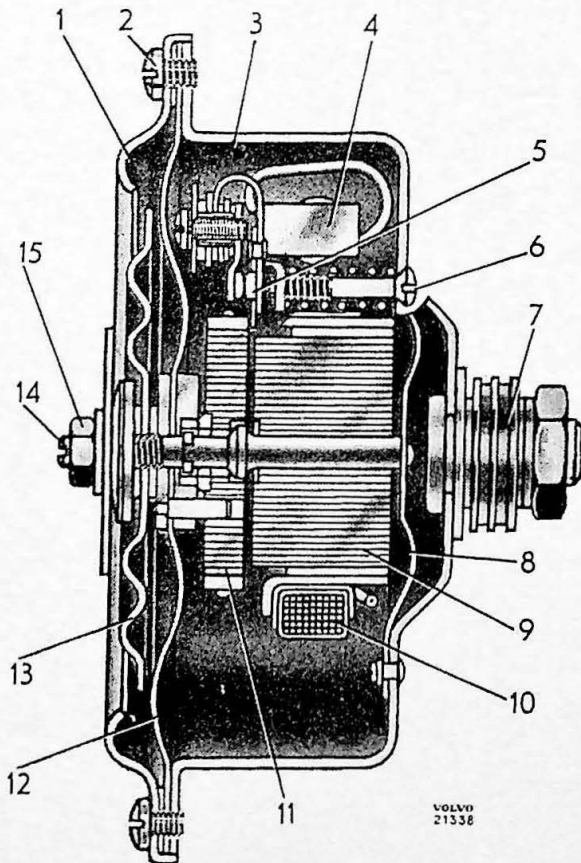

- 1. Cover
- 2. Screw
- 3. Housing
- 4. Condenser
- 5. Contact breaker
- 6. Armature adjusting screw
- 7. Attachment
- 8. Leaf spring
- 9. Electro-magnet
- 10. Winding
- 11. Armature plate
- 12. Diaphragm
- 13. Ringer disc
- 14. Adjusting screw
- 15. Lock nut

Fig. 9. Horn (Bosch).

REPAIR INSTRUCTIONS

Battery Maintenance

See under "Battery" in the General Part (PV—10).

Removal

1. Remove cable clamps from battery terminals. Use a puller if the clamps are very tight.
2. Loosen the wing nuts on the retainer band and lift out the battery.
3. Brush off the battery with a brush and rinse clean with tepid water.
4. Clean the battery shelf and the cable clamps. Use a wire brush or special pliers on the cable clamps.

Installation

1. Place the battery in position. Ensure that it is turned the right way. Tighten in position by means of the retainer band and the wing nuts.
2. Tighten the cable clamps on the battery terminals. The negative terminal is earthed.
3. Smear terminals and cable clamps with vaseline.

Dynamo

Precautions before removing

See under "Dynamo" in the General Part.

Removal

1. Remove cable clamp from battery negative terminal.
2. Disconnect cables from dynamo.
3. Loosen the pulley belt tension device and lift off pulley belt.
4. Remove the two bolts attaching dynamo to engine and remove.
5. Clean dynamo externally with a cloth soaked in petrol.

For dynamo overhaul, see General Part.

Installation

Installation is carried out in the reverse order to removal. The attachment bolts should be secured by means of lock washers or lock nuts and cotter pins. Do not stretch the pulley belt too

tightly. It should be possible, when tension is correct, to press in the belt about 10 mm ($\frac{25}{64}$ "") at a point about midway between the pulleys. Ensure that cables are connected correctly.

Charging relay Adjustment in car

See under "Charging Relay" in General Part.

Removal

1. Disconnect the three cables from the charging relay.
2. Remove relay from mounting board.
3. Clean thoroughly externally.

Installation

1. If the relay is to be replaced, make sure that the correct type is fitted.
2. Screw into position on the mounting board.
3. Connect the cables. The cable from the dynamo armature terminal is connected to the terminal marked A, Arm or D⁺, from the dynamo field terminal to the terminal marked Fld or DF, and from the battery to Bat or B.

Starting motor

Precautions before removal

See under "Starting motor" in General Part.

Removal

1. Remove cable clamp from battery negative terminal.
2. Disconnect the cables from the starting motor relay or solenoid switch.
3. Remove the screws which hold the starting motor in position on the flywheel housing and remove it.
4. Clean externally with a cloth soaked in petrol.

For overhaul, see General Part.

Installation

Installation is carried out in the reverse order to removal. Tighten nuts evenly but not too hard. Connect cables carefully.

Ammeter

Examination and testing

See "Ammeter" in General Part.

Removal and installation

See "Replacement of ammeter" in Part 11.

Fuel gauge

Examination and testing

See "Fuel gauge" in General Part.

Removal and installation

See "Replacement of fuel gauge" in Part 11.

Headlights

Replacement of headlights

If a headlight is to be completely dismantled follow the instructions below. For partial dismantling follow the relevant instructions.

1. Remove the headlight rim screw (fig. 10). Remove rim by pulling out the lower part slightly and then lifting upwards.
2. Loosen the screws (1—3, fig. 11) on the headlight unit holder (4). Turn until the

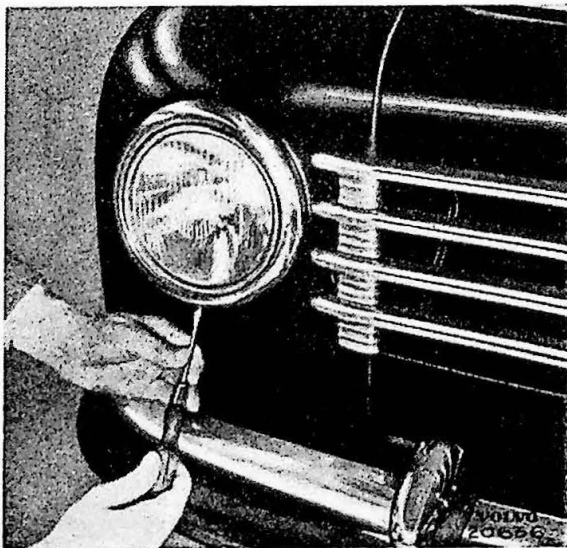

Fig. 10.

hooks are free from the screws and then lift out the holder, headlight unit and bulb-holder.

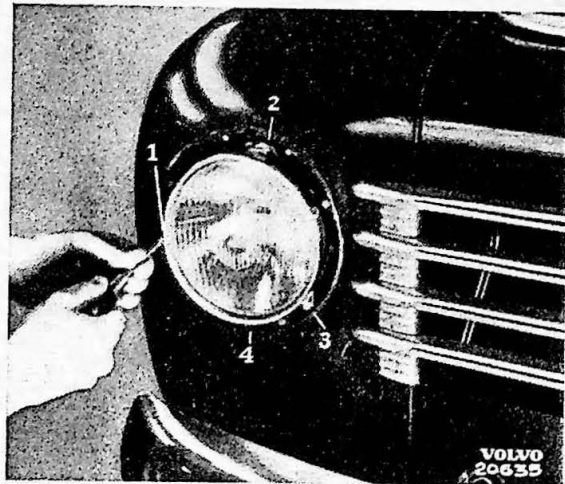

Fig. 11.



Fig. 12.

3. Remove the spring holding the bulb-holder to the headlight unit (fig. 12). Separate the unit from the holder and remove the bulbs.
4. Disconnect the cables from the bulb-holder and mark the cables to assist re-connection and avoid mistakes. If only the bulb-holder is to be replaced, then it is best to disconnect one cable at a time and connect them directly to the new bulb-holder.
5. Loosen the adjustment screws (1 and 2, fig. 13) 8—10 turns. Unhook the springs (3—6)

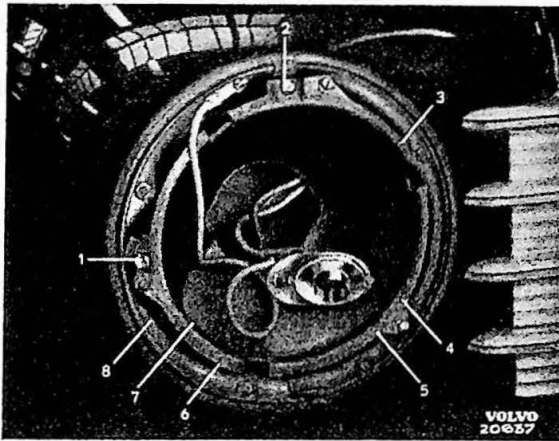

Fig. 13.

- from the mounting ring (7). Remove the mounting ring from the holder (8).
6. Remove the springs and adjustment screws from the holder.
 7. Loosen the holder from the mud-guard and pull out the cable and the rubber bushing. Remove rubber seals.
 8. Instal in reserve order. Make sure that the cables are correctly connected and that the screws are properly tightened. Do not forget to connect the earthing cable.

Replacement of bulbs

1. Proceed as shown in points 1—3 in "Replacement of headlights".



Fig. 14.

2. Remove the faulty bulb.
3. Insert a new bulb. This is done as shown in fig. 14. Do not touch the glass with the fingers but just pull the socket as far out of the box as is necessary to fit the bulb. Dirt, oil etc. on the glass burn on and can damage the reflector when they carbonize. The headlight effectivity is thus reduced considerably.
4. Fit the above parts in the reverse order to that employed when removing.

Alignment of headlights

See General Part.

Number plate lighting

Replacement of bulb in number plate lighting

1. Remove the rubber sleeve and then push the unit with lamp forwards by using a screw-driver as shown in fig. 15.
2. Remove the faulty bulb by pressing it inwards and anti-clockwise at the same time.
3. Fit the new bulb. Do not touch the glass with the fingers, fig. 16.
4. Replace the unit in the holder and press on the rubber sleeve.

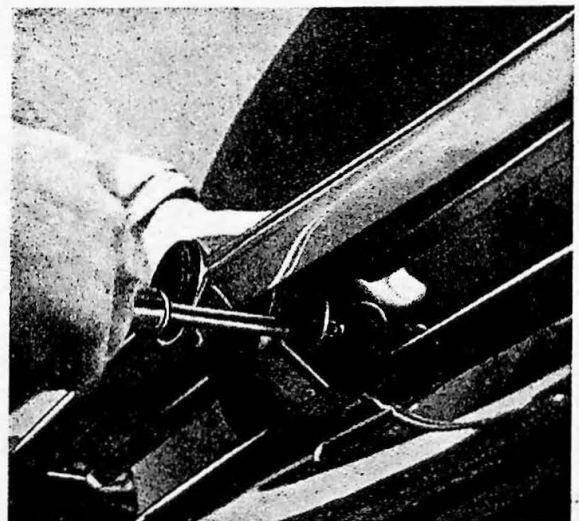

Fig. 15.



Fig. 16.

Stop- and tail lights

Replacement of stop- and tail lights

1. Loosen the screw which holds the housing on the bulb-holder. Pull housing backwards and remove.
2. Remove the faulty bulb and fit the new as shown in fig. 17. There are two types of bulb-holder. The late production bulb-holder only allows the fitting of the bulb in one position.
3. If the bulb-holder is to be replaced, the nuts on the inside of the mud guard are removed after the cables have been marked and disconnected from the bulb-holder.
4. Ensure that the rubber washer lies correctly so that a good seal is ensured.

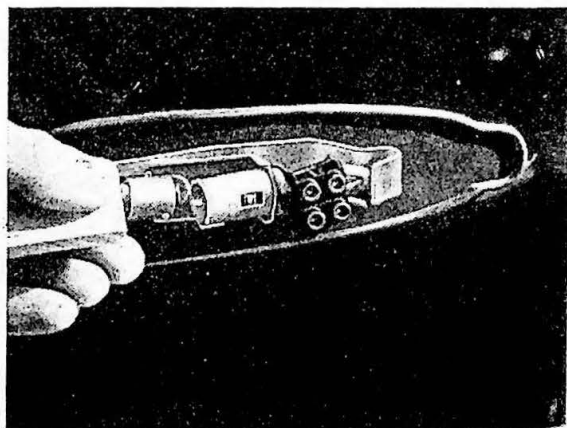

Fig. 17.

Traffic indicators

Trafficator type (semaphore)

This type of traffic indicator is fitted on PV

444 A. It is recessed into the body to the rear of the door and is held in position by means of screws. The operating switch is located on the instrument panel.

When fitting this type of traffic indicator make sure that the upper part of the indicator arm is not bent in any way. One result of this can be that the electro-magnet or hinging mechanism may jam.

Cleaning and lubrication

The traffic indicator is unscrewed from the body, cleaned in petrol and blown dry with compressed air.

Lubricate sparingly. Oil the electro-magnet very slightly. The roller, shaft, sliding surfaces and spiral spring bearing on the lever catch are smeared with grease and coated with oil. The inside ends of the bearing are lubricated with a few drops of oil. The catch and return spring, as well as the contact and spring for the bulb, are smeared with grease.

SAE 10 or SAE 20 oil is used for lubrication as well as heat- and cold-resisting grease which contains vaseline.

Traffic indicators, blinker type

Removal of housing with switch

1. Remove the steering wheel as described in Part. 6.
2. Screw out the arm (1, fig. 18) on the lever (4). Remove the cotter pin (2), washer (3) and lift the lever and rubber stop (5) out of the housing (6).

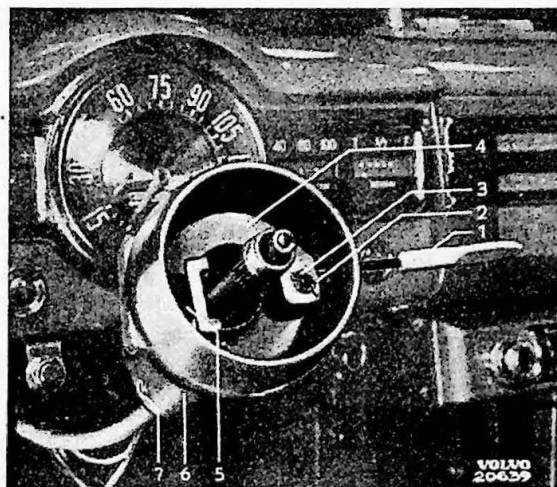

Fig. 18.

3. Remove the two screws which hold the switch (1, fig. 19) in the housing.
4. Disconnect the cables (1 and 2, fig. 20) from the blinkers and the cables (3—6) at the connector (7). Mark all cables to ensure correct reconnection.
5. Loosen the retainer screw (7, fig. 18) entirely and slide the housing off the steering column. Remove switch and cable.

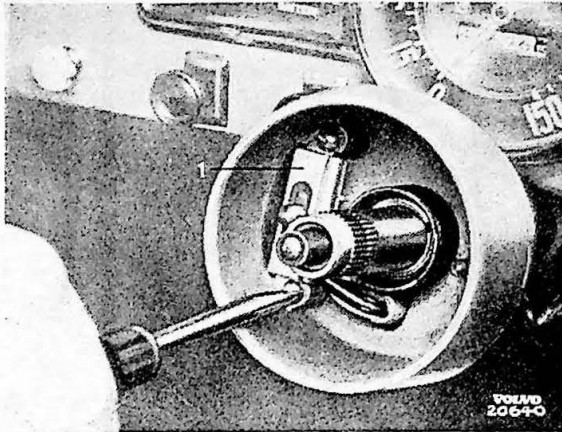

Fig. 19.

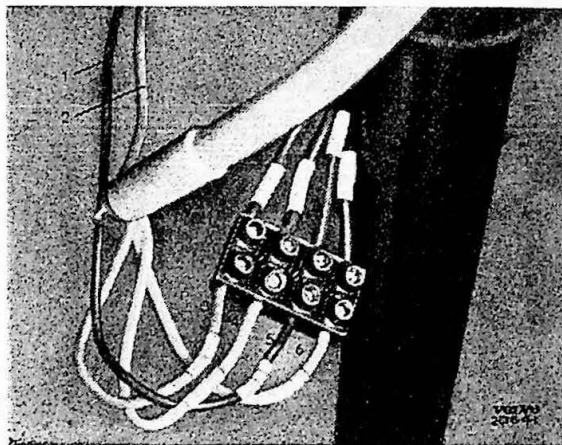

Fig. 20.

From PV 444 chassis no. 26905 onwards and PV 445 chassis no. 1991 onwards there is a new type traffic indicator switch fitted. See figs. 21 and 22.

The operating arm, which is on the left-hand side of the steering wheel, is connected to the switch by means of a hub and a shaft.

The switch is attached to the housing by means of four screws (7).

Removal of the housing and switch are carried out as shown above. To remove the switch from

the housing, the hub must be removed. This is done by loosening the nut which holds the hub on the shaft.

The cables are coupled to a 6-point connector under the instrument panel.

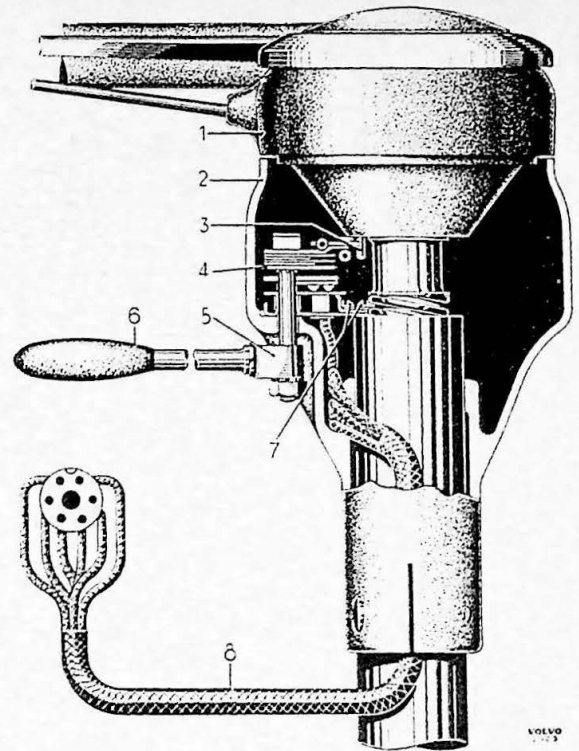

Fig. 21.

- | | |
|-----------------------------|----------------------------------|
| 1. Steering wheel | 5. Hub |
| 2. Housing | 6. Lever |
| 3. Pin | 7. Screws for switch |
| 4. Traffic indicator switch | 8. Cables with 6-point connector |

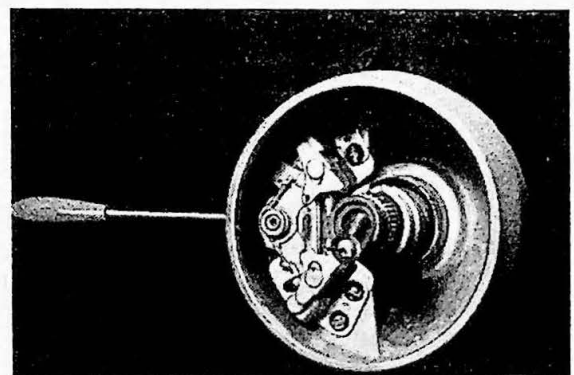

Fig. 22.

Installation

1. Thread cable and switch through housing and screw switch into position.

2. Stretch the cable and press it into the groove in the housing. Screw in the retainer screw.
3. Slide the housing down the steering column and tighten the screw so that the housing is firmly in position. Make sure that it is sufficiently far down the column so that it does not come into contact with the steering wheel hub when this is fitted.
4. Couple the cables to the blinkers and the connector and ensure, with the help of the markings, that the cables are connected correctly.
5. Oil the lever bearing pin and press it into position. Fit the rubber stop on the lever.
6. Screw the arm into the lever. Switch on the ignition and make sure that the blinkers operate properly. Move the lever back into the neutral position and switch off the ignition.
7. Fit the washer and cotter pin to the end of the shaft.
8. Fit the steering wheel as shown in Part 6. Make sure that the switch is in the neutral position before the steering wheel is fitted. Do not forget to adjust the housing after the steering wheel nut is tightened.

When fitting the housing and switch of later production follow the relevant points above. Adjustment of the housing by means of a jig (see Part 6) is not necessary. After the steering wheel is fitted adjust the housing so that there is a clearance of 1—1,5 mm ($1/32''$ — $1/16''$) between the upper part of the housing and the steering wheel hub.



Fig. 23.

Replacement of bulbs

Loosen the two screws on the upper part and lift off the cover. The outer bulbs are then accessible for replacement. The central bulb is attached to a bracket which is held in place by means of two screws. This bracket must be loosened as shown in fig. 23. Do not touch the glass with the fingers as this reduces the effectivity of the bulb if it is smeared with grease or oil.

The covers on the blinker type traffic indicators are attached by means of two screws as shown in fig. 24.

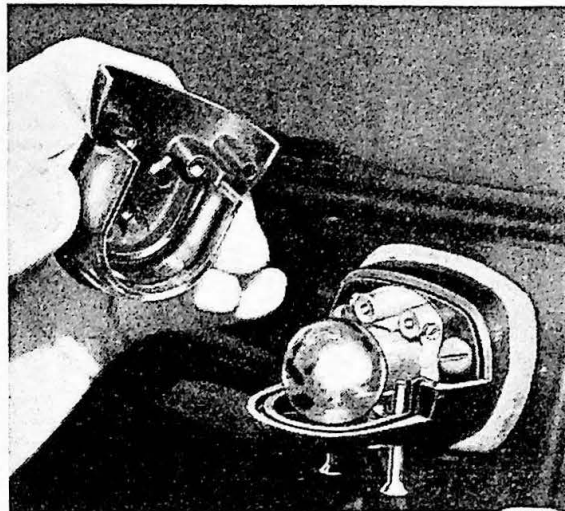

Fig. 24.

Horn

Examination and adjustment

See "Horn" in General Part.

Removal and installation

On cars with the horn behind the radiator grille, remove the four garnish mouldings, disconnect the cables and remove the horn. On special models, the double-tone horn is fitted on the mounting board.

Installation should be carefully carried out, ensuring that a good earth is obtained if an earthing cable is not used.

The tone of the horn depends on the suspension rubber and springs which should be carefully checked.

Double horns are connected to the battery by means of a relay. This is situated on the left-hand tubular member, on later models on the left-hand wheel housing.

Instrument- and internal lights

The instrument lighting consists of three bulbs in sockets attached to the instrument mounting plates. The traffic indicator light is also fitted to the speedometer mounting plate. All bulbs are accessible for replacement from the rear of the instrument panel.

Internal lighting consists of a light either in the roof or on the door pillar. This is accessible after the glass cover has been removed. Ignition key lighting (door contact) is accessible from the rear of the instrument panel.

Main lighting switches

The main headlight switch has three positions: off, parking lights and headlights.

The foot dipper switch has two positions: full and dipped. This switch is attached by means of screws to the underneath of the lower part of the mounting plate.

Both the main switch and the dipper switch must be in good condition if the best lighting power is to be obtained. Damaged or faulty switches must, therefore, be replaced. If headlight power is bad then the switches must be examined and the voltage drop through them measured. This voltage drop should not exceed 1/10 volt.

The instrument lighting switch is situated low down on the left hand side of the instrument panel. The button operates an adjustable resistance so that the power of the lights may be regulated. This switch should be replaced if it is damaged.

As far as measurements of the electrical system are concerned, see General Part.

Electric cables

The electric cables connecting the battery and the dynamo with the various instruments and electrical devices are shown in the various circuit diagrams. These diagrams show also marking and cross-section of the cables.

In order to avoid the menace to traffic safety as represented by "one-eyed" cars, the electrical system in later models has been adapted so that the parking lights operate even when the headlights are on. If a headlight bulb should burn out, the parking light on that side functions. This change is effective from the following chassis numbers onwards:

PV 444	from chassis no. 46455 onwards
PV 445 DH	" " " 797 "
PV 445 DS	" " " 18 "
PV 445 D	" " " 2938 "

If a cable has broken or is earthed, it must be replaced. Ensure that the new cable used has the same cross-section as the original. Overloading results in heat production which can result in damage not only to the cable itself but also to the car.

Fuses

Fuses on PV 444—445 consist of 8 amp. and 25 amp. melt-type fuses. They are contained in a fuse box on the mounting board. There is a card under the fuses showing the various circuits covered by the fuse in question.

For further information about fuses see General Part.

FAULT TRACING

For tracing of faults in the electrical system see "Fault tracing" in the General Part (PV—10).

SPECIFICATIONS

Battery

Voltage	6 volts
Negative terminal	Earthed
Battery capacity, standard	85 amp. hours
Specific gravity of electrolyte, fully charged battery	1,275—1,285
when re-charging necessary	1,230

Recommended charging current for various batteries:

Make	Type	Charging current
Boliden	3F06	6,0 amps.
SAAJ	F 13	5,0 amps.
Tudor	3 DF6	7,5 amps.
Warta	DFOC	7,5 amps.

Dynamo

Voltage	6 volts
Earth connection	Negative terminal
Direction of rotation	Clockwise

Type

Up to engine no. 12096	Auto-Lite GDZ-4821 A
Engine no. 12097—43099	Auto-Lite GDZ-6001 C
Output, continuous	Max. 35 amps.
Brushes, designation, 1 set = 2 brushes	Auto-Lite GGU-2012 S
1 brush	Auto-Lite GGU-1012

Test values

Brush spring tension	1,0—1,5 kg (35—53 oz.)
Field coil	1,3—1,5 amps. at 5 volts
Dynamo as motor (motoring draw)	3,9—4,4 amps. at 5 volts
Charging, cold dynamo:	
6,4 volts 0 amps.	870—970 r.p.m.
8 volts 35 amps.	1800—2000 r.p.m.
Charging, warm dynamo:	
6,4 volts 0 amps.	950—1050 r.p.m.
8 volts 35 amps.	2150—2350 r.p.m.

Type

From engine no. 43100	Bosch LJ/GJM 160/6/1500R10
Rated output, continuous	Max. 40 amps.
Brushes, designation, positive brush, (1)	WSK 35 L 1
negative brush, (1)	WSK 35 L 3

Test values

Brush spring tension	0,45—0,60 kg (16—21 oz.)
Field coil	3,8—4,2 amps. at 5 volts
Dynamo as motor (motoring draw)	6,8—7,2 amps. at 5 volts
Charging, cold dynamo (+20° C) (68° F):	
6,4 volts 0 amps.	1000—1050 r.p.m.
8 volts 40 amps.	1500—1700 r.p.m.
Charging, warm dynamo (+60° C) (140° F):	
6,4 volts 0 amps.	1080—1150 r.p.m.
8 volts 40 amps.	1600—1800 r.p.m.

Charging relay

Voltage	6 volts
Earth connection	Negative terminal

Type

(For dynamo Auto-Lite GDZ-4821 A)	Auto-Lite VRP-4007 C2
(For dynamo Auto-Lite GDZ-6001 C)	Auto-Lite VRP-6003 A
Series resistances	7 ohms (1) and 38 ohms (1)

Test values

Cut-out relay:

Armature air gap031"—.034" (0,79—0,86 mm)
Contact gap	Min. .015" (0,38 mm)
Closes at	6,5 volts
Opens at	4,1—4,8 volts (open circuit) 4—6 amps. (closed circuit)

Voltage regulator:

Armature air gap048"—.052" (1,22—1,32 mm)
Control voltage is adjusted to	7,35 volts

Current regulator:

Armature air gap048"—.052" (1,22—1,32 mm)
Control current is adjusted to	35 amps.
Test values apply in a temperature of	20° ± 1° C (68 ± 2° F)

Type

(For dynamo Bosch LJ/GJM 160/6 1500R10)	Bosch RS/UA 160/6/30
Balancing resistance aR	5,5—6,0 ohms
Control resistance w1R	4,0—5,0 ohms

Test values

Cut-out relay:

Armature air gap	0,8—1,25 mm (.032"—.050")
Contact gap	0,4—0,8 mm (.016"—.032")
Closes at	5,8—6,3 volts
Opens at	4—9 amps. (closed circuit)

Voltage regulator:

Armature air gap	0,8—1,2 mm (.032"—.047")
Contact gap (lower)	0,26—0,4 mm (.001"—.016")
Control voltage adjusted to (idling and half field current)	7,1—7,4 volts

Current regulator:

Armature air gap	1,0—1,45 mm (.039"—.057")
Control current is adjusted to	40 ± 1 amps.
Test values apply in a temperature of about 20° C (68° F)	

Starting motor

Voltage	6 volts
Earth connection	Negative terminal
Direction of rotation	Clockwise

Type

(with starting relay and Bendix drive) up to engine no. 43004	Auto-Lite MZ-4139
Output	0,75 b.h.p.
Number of teeth on gear	9
Brushes, designation, 1 set = 4 brushes	Auto-Lite MZ-2012AS
positive brushes (2)	Auto-Lite MZ-12
negative brushes (2)	Auto-Lite MZ-1034

Test values

Mechanical:

Armature axial clearance	0,15—1,15 mm (.0059"—.0453")
Brush spring tension	1,2—1,5 kg (42—53 ozs.)
Distance from face of mounting flange to edge of pinion	1.220"—1.342" (31—34 mm)

Electrical:

No-load:

Check time (idling)	Max. 15 seconds
5.0 volts and max. 68 amps.	Min. 4000 r.p.m.

Stalled starting motor:

2 volts and max. 280 amps.	Min. 0.6 kgm (4.4 lb.ft)
---------------------------------	--------------------------

Starting relay:

Test values:

Current consumption of windings	2,9—3,3 amps. at 6 volts
Closes at	3.0—4.0 volts
Opens at	0,5—1,25 volts

Type (with solenoid switch) from engine no. 43005

Bosch EGD 0,6/6 AR19

Output

0,75 b.h.p.

Rated output (at —40° C) (—40° F)

0,6 b.h.p.

Number of teeth on gear

9

Brushes, designation (4)

DSK 35/5

Test values

Mechanical:

Armature axial clearance	0,15—0,30 mm (.006"—.012")
Brush spring tension	0,8—0,9 kg (28—32 ozs.)
Distance from pinion to ring gear	3 mm (.118")
Armature brake friction torque	3—5 kgcm
Gear idling torque	0,4—0,8 kgcm

Electrical:

No-load:

Check time (idling)	Max. 15 seconds
5,5 volts and 65—75 amps.	3500—4500 r.p.m.

Loaded starting motor:

4,5 volts and 260—280 amps.	750—850 amps.
----------------------------------	---------------

Stalled starting motor:

3,5 volts and 450—480 amps.	Min. 1,33 kgm (9.64 lb.ft)
----------------------------------	----------------------------

(r.p.m.=0)

Solenoid switch, type

SSM 120 L 2

Test values:

Current consumption of windings:

Between connection 50 and body	9—12 amps. at 5,0 volts
Between connection 50 and 30	31—35 amps. at 5,0 volts
Operating voltage, closes	2,5—3,3 volts
opens	0,8—1,6 volts

Horn

Voltage

6 volts

Type

Auto-Lite HW

Armature air gap:

Horn with low tone

.0495" (1,26 mm)

Horn with high tone

.0400" (1,02 mm)

Adjusting screw set for

6,2 volts and 15 amps.

Type

Bosch FDE 6/1

Armature air gap

0.55—0.65 mm (.0217"—.025")

Current consumption:

Setting value

5,2—5,9 amps.

Limiting value

4,0—6,3 amps.

Voltage for armature attraction

Min. 4 volts

Voltage for full power

6—8 volts

Type	Bosch HO/FDF 6/3 (low tone)
Type	Bosch HO/FDF 6/4 (high tone)
Armature air gap:	
Low tone type	0,50—0,65 mm (.020"—.025")
High tone type	0,45—0,55 mm (.018"—.022")
Current consumption:	
Setting value, low tone type	4,7—5,3 amps.
high tone type	4,2—4,8 amps.
Limiting value, low tone type	3,5—5,6 amps.
high tone type	3,3—5,2 amps.
Voltage for armature attraction	4 volts
Voltage for full tone value	6—8 volts

Fuses

	Number	Type
PV 444 A, B and BQ; PV 445 A and B	3	8 amp.
	1	25 "
PV 444 BS and BSQ	2	8 "
	2	25 "
PV 444 C and PV 445 C	5	8 "
	1	25 "
PV 444 CS	4	8 "
	2	25 "
PV 444 D and PV 445 D	4	8 "
	2	25 "
PV 444 DS	3	8 "
	3	25 "
PV 444 E	4	8 "
	2	25 "
PV 444 ES	3	8 "
	3	25 "

Bulbs

	Number	Watts	Socket
Headlights	2	45—40	BA 20 d
Parking lights	2	1,5	BA 9 s
Number plate lighting	1*	5	BA 15 s
Stop and tail lights, PV 444 up to chassis no. 26686	2	20/5	BA 15 d
PV 444 from chassis no. 26687	2	20/5	BA 15 d spec.
Instrument lights, PV 444 A and PV 445 A	3	1,5	BA 9 s
from PV 444 B and PV 445 B	3	2,4	BA 9 s
Traffic indicators, trafficator type	2	3	S 5
blinkers (roof or side)	2 and 3	45	BA 15 s

(Only the following bulbs are suitable for the blinker type traffic indicators: Luma 613, Phillips 6407 and Osram 7520. Volvo Part 182033)

Control light for traffic indicators, PV 444 A and PV 445 A	1	2,4	BA 9 s
Control light for headlights, PV 444 A	1	2,4	BA 9 s
Control light for headlights from PV 444 B and PV 445 B onwards ..	1	1,5	BA 9 s
Roof light	1	15	BA 15 s
Internal light (door switch), PV 444 B	1	1,5	BA 9 s
Internal light from PV 444 C onwards (combined with roof light) ..	1	15	BA 15 s

* PV 445 S and H have two of these lights.

Headlight beam adjustment

The beams are adjusted on a wall at a distance of 5 m (16 ft.) with an empty car and headlights full on.

Vertical adjustment	5 cm (2") below the headlight horizontal centre line (3" at 25 ft.)
Horizontal adjustment	5 cm (2") sideways from the headlight vertical centre line (3" at 25 ft.)

Illustration I.

1. Left-hand stop and tail light
2. Right-hand stop and tail light
3. Connector
4. Fuel gauge tank unit
5. Left hand traffic indicator
6. Right hand traffic indicator
7. Roof light
8. Switch
9. Horn button
10. Instrument lighting switch
11. Fuel gauge
12. Ignition switch
13. Ammeter
14. Traffic indicator switch
15. Starting button
16. Traffic indicator control light
17. Instrument lights
18. Headlight control light
19. Ignition coil
20. Light switch
21. Fuse box
22. Battery
23. Relay
24. Connector
25. Contact for stop lights
26. Foot dipper switch
27. Starting motor
28. Ignition cable
29. Distributor
30. Horn
31. Sparking plugs
32. Parking lights
33. Headlights (dipped)
34. Headlights (full)
35. Left-hand headlight
36. Right-hand headlight
100. *Circuit for Bosch traffic indicators*
101. Right-hand traffic indicator
102. Left-hand traffic indicator
103. Control light
104. To fuse
105. Traffic indicator switch

Grön=Green
 Svart=Black
 Röd=Red
 Vit=White
 Blå=Blue
 Brons=Bronze

Illustration II.

1. Left-hand stop and tail light
2. Right-hand stop and tail light
3. Connector
4. Fuel gauge tank unit
5. Roof light
6. Right-hand traffic indicator
7. Left-hand traffic indicator
8. Switch
9. Horn button
10. Instrument lighting switch
11. Ammeter
12. Ignition switch
13. Fuel gauge
14. Traffic indicator switch
15. Starting button
16. Headlight control light
17. Traffic indicator control light
18. Connector
19. Ignition coil
20. Battery (6V, 85 amp. hrs.)
21. Relay
22. Light switch
23. Fuse box
24. Starter motor
25. Sparking plugs
26. Ignition cable
27. Distributor
28. Contact for stop lights
29. Foot dipper switch
30. Connector
31. Horn
32. Parking lights
33. Headlights (dipped)
34. Headlights (full)
35. Left-hand headlight
36. Right-hand headlight
100. Instrument lighting

Illustration III.

1. Left-hand stop and tail light
2. Right-hand stop and tail light
3. Fuel gauge tank unit
4. Connector
5. Left-hand traffic indicator
6. Right-hand traffic indicator
7. Roof light
8. Switch
9. Horn button
10. Fuel gauge
11. Ignition switch
12. Instrument lighting switch
13. Ammeter
14. Starting button
15. Instrument lights
16. Traffic indicator control light
17. Headlight control light
18. Connector
19. Relay
20. Battery
21. Light switch
22. Contact for stop lights
23. Fuse box
24. Ignition coil
25. Starting motor
26. Foot dipper switch
27. Horn
28. Ignition cable
29. Distributor
30. Connector
31. Sparking plugs
32. Parking lights
33. Headlights (dipped)
34. Headlights (full)
35. Left-hand headlight
36. Right-hand headlight
37. Dynamo

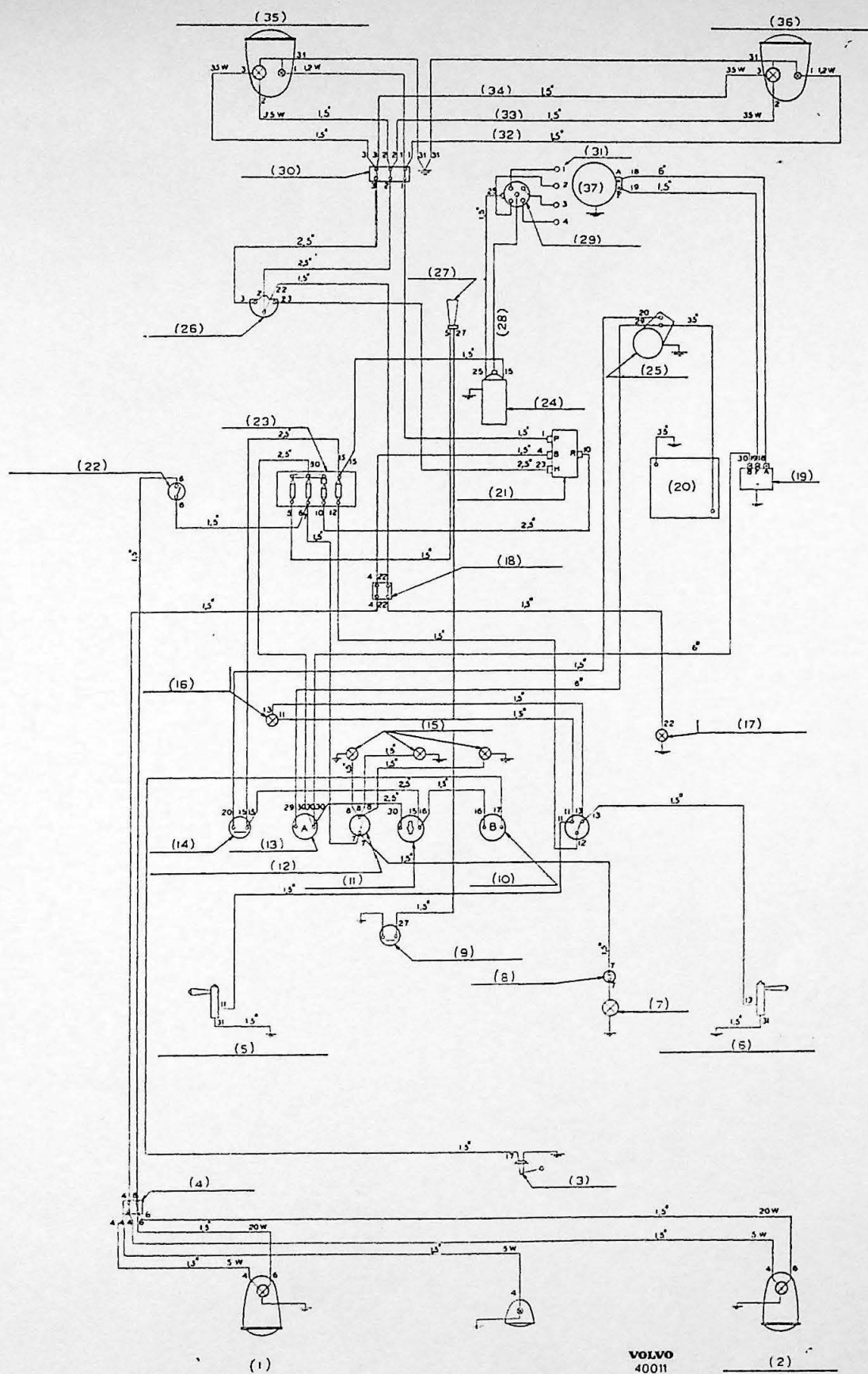

Illustration III. Electrical circuits for PV 444 A (late production) and PV 445 A.

Chassis nos.: PV 444 A: 5411-5499, 5510-5511, 7505-12504.
 PV 445 A: 4-500.

Illustration IV.

1. Left-hand tail and stop light
2. Right-hand tail and stop light
3. Number plate light
4. Fuel gauge tank unit
5. Connector
6. Roof light
7. Switch
8. Traffic indicators (blinkers)
9. Connector
10. Traffic indicator switch
11. Connector
12. Blinker relay
13. Door switch
14. Horn button
15. Ignition switch
16. "St" terminal
17. "Acc" terminal
18. "Am" terminal
19. Instrument lighting
20. Headlight control light
21. Instrument lighting rheostat
22. Ammeter
23. Connector
24. Cigarette lighter (not standard)
25. Fuel gauge
26. Ignition switch lighting
27. Contact for stop lights
28. Fuse box
29. Foot dipper switch
30. Relay
31. Battery
32. Starting motor
33. Connector
34. Light switch
35. Order of firing
36. Connector
37. Dynamo
38. Distributor
39. Ignition coil
40. Horn
41. Parking lights
42. Headlights (full)
43. Headlights (dipped)
44. Connector
45. Left-hand headlight
46. Right-hand headlight

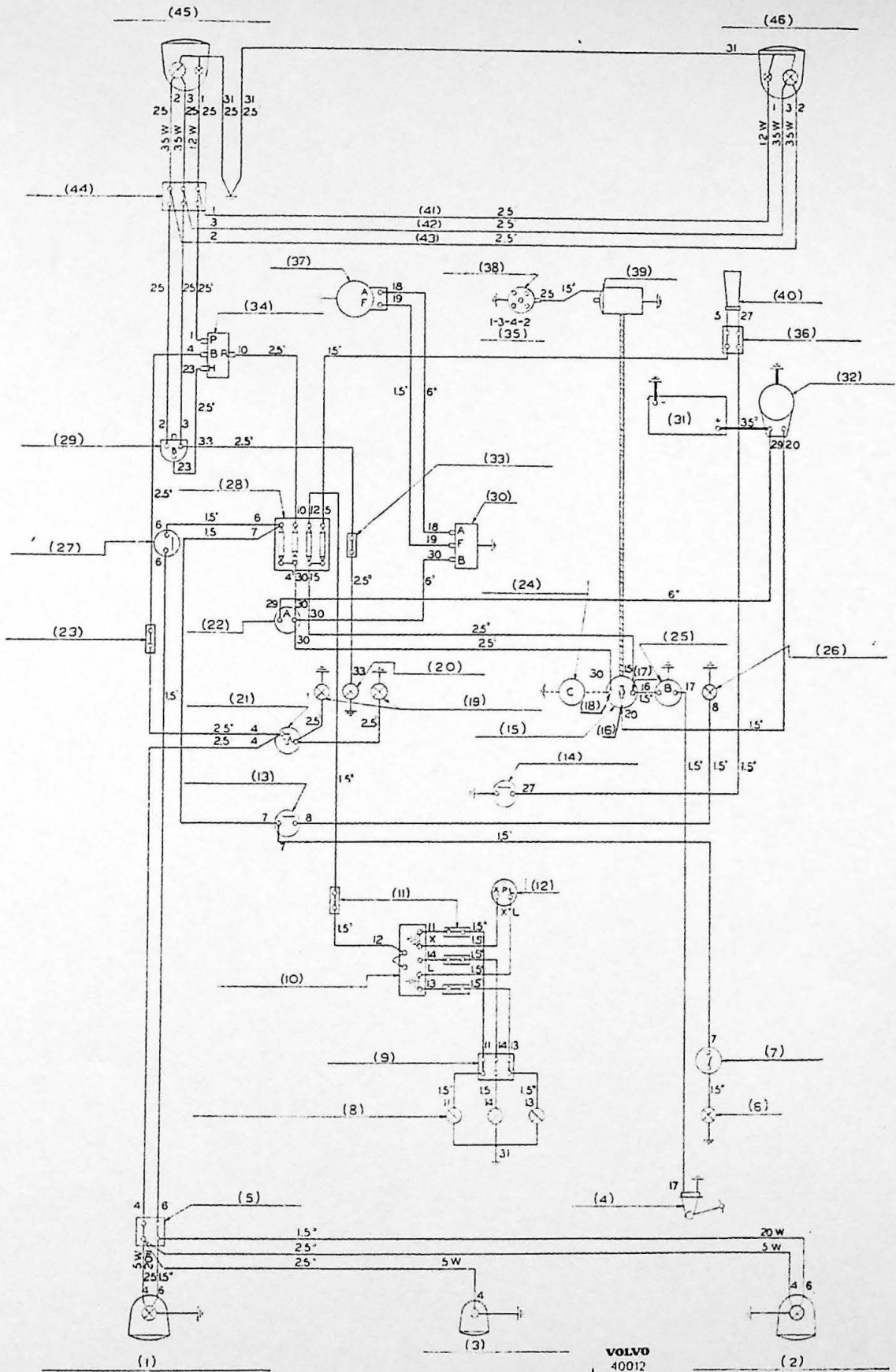

Illustration IV. Electrical circuits for PV 444 B and PV 445 B.

Chassis nos.: PV 444 B: 12505-2000+.
 PV 445 B: 501-1600.

Illustration V.

1. Right-hand stop and tail light
2. Left-hand stop and tail light
3. Number plate light
4. Fuel gauge tank unit
5. Connector
6. Roof light
7. Switch
8. Traffic indicators
9. Connector
10. Traffic indicator switch
11. Connector
12. Instrument lighting rheostat
13. Instrument lights
14. Connector
15. Horn button
16. Blinker relay
17. Ignition switch
18. "Am" terminal
19. "Acc" terminal
20. Fuel gauge
21. "St" terminal
22. Ammeter
23. Relay
24. Cigarette lighter (special model car only)
25. Headlight control light
26. Connector
27. Heater
28. Fuse box
29. Switch
30. Connector
31. Contact for stop lights
32. Foot dipper switch
33. Fog lights, spot light, reversing light
34. Connector
35. Dynamo
36. Battery
37. Order of firing
38. Horn
39. Distributor
40. Starting motor
41. Ignition coil
42. Connector
43. Light switch
44. Relay
45. Horn (special model car only)
46. Headlights (dipped)
47. Headlights (full)
48. Parking lights
49. Left-hand headlight
50. Right-hand headlight

Grön = Green
 Svart = Black
 Röd = Red
 Vit = White
 Grå = Grey
 Gul = Yellow

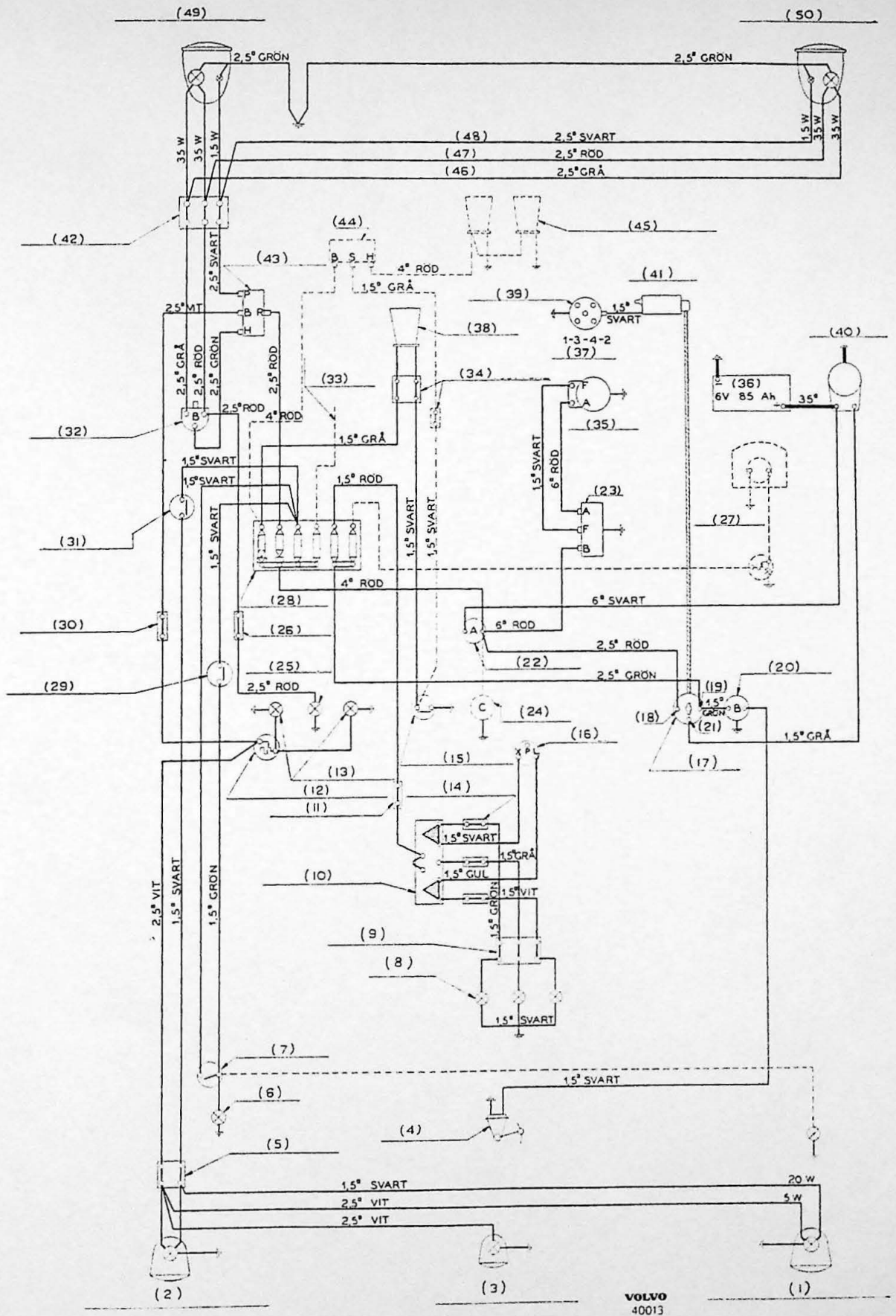

Illustration V. Electrical circuits for PV 444 C (early production).
 Chassis nos.: PV 444 C: 20005-26904.

Illustration VI.

1. Right-hand stop and tail light
2. Left-hand stop and tail light
3. Number plate light
4. Fuel gauge tank unit
5. Switch
6. Roof light
7. Connector
8. Connector
9. Traffic indicator switch (side)
10. Traffic indicator switch (roof)
11. Connector
12. Connector
13. Connector
14. Ammeter
15. Horn button
16. Blinker relay
17. Instrument lighting rheostat
18. Instrument lights
19. Contact for stop lights
20. Door contact
21. Headlight control light
22. "Am" terminal
23. "St" terminal
24. Fuel gauge
25. "Acc" terminal
26. Cigarette lighter (special model car only)
27. Ignition switch
28. Heater motor
29. Defroster motor
30. Relay
31. Dynamo
32. Dipper foot switch
33. Fuse box
34. Connectors
35. Connector
36. Fog lights
37. Order of firing
38. Battery
39. Starting motor
40. Horn
41. Lighting switch
42. Distributor
43. Ignition coil
44. Lighting switch
45. Connector
46. Headlights (dipped)
47. Horn (special model car only)
48. Headlights (full)
49. Parking lights
50. Left-hand headlight
51. Right-hand headlight

Grön = Green
 Svart = Black
 Röd = Red
 Vit = White
 Blå = Blue
 Grå = Grey
 Gul = Yellow
 Brun = Brown

Illustration VII.

1. Right-hand stop and tail light
2. Left-hand stop and tail light
3. Number plate light
4. Fuel gauge tank unit
5. Switch
6. Roof light
7. Connector
8. Connector
9. Traffic indicator switch (side)
10. Traffic indicator switch (roof)
11. Connector
12. Connector
13. Connector
14. Ammeter
15. Horn button
16. Blinker relay
17. Instrument lighting rheostat
18. Instrument lights
19. Contact for stop lights
20. Door contact
21. Headlight control light
22. "Am" terminal
23. "St" terminal
24. Fuel gauge
25. "Acc" terminal
26. Cigarette lighter (special model car only)
27. Ignition switch
28. Heater motor
29. Defroster motor
30. Relay
31. Dynamo
32. Foot dipper switch
33. Fuse box
34. Connectors
35. Connectors
36. Fog lights
37. Order of firing
38. Battery
39. Starter motor
40. Horn
41. Lighting switch
42. Distributor
43. Ignition coil
44. Lighting switch
45. Connector
46. Headlights (dipped)
47. Horn (special model car only)
48. Headlights (full)
49. Parking lights
50. Left-hand headlight
51. Right-hand headlight

Grön=Green
 Svart=Black
 Röd=Red
 Vit=White
 Blå=Blue
 Grå=Grey
 Gul=Yellow
 Brun=Brown

Illustration VIII.

1. Left-hand stop and tail light
2. Right-hand stop and tail light
3. Number plate light
4. Fuel gauge tank unit
5. Connector
6. Roof light
7. Switch
8. Traffic indicator switch
9. Left-hand traffic indicator
10. Right-hand traffic indicator
11. Blinker
12. Traffic indicator control light
13. Brake contact
14. Instrument lighting rheostat
15. Ammeter
16. "St" terminal
17. Fuel gauge
18. "Acc" terminal
19. "Am" terminal
20. Cigarette lighter (special model car only)
21. Ignition switch
22. Instrument lighting
23. Headlight control light
24. Door contact
25. Adjustable rheostat switches
26. Horn button
27. Heater
28. Defroster fan
29. Relay
30. Connectors
31. Fuse box
32. Dynamo
33. Foot dipper switch
34. Light switch
35. Connector
36. Fog lights, spot light reversing light
37. Battery
38. Starter motor
39. Order of firing
40. Horn
41. Ignition coil
42. Distributor
43. Horn (special model car only)
44. Connector
45. Relay
46. Headlights (dipped)
47. Headlights (full)
48. Parking lights
49. Left-hand headlight
50. Right-hand headlight

Grön=Green
 Svart=Black
 Röd=Red
 Vit=White
 Blå=Blue
 Grå=Grey
 Gul=Yellow
 Brun=Brown

Illustration IX.

1. Left-hand stop and tail light
2. Right-hand stop and tail light
3. Number plate light
4. Fuel gauge tank unit
5. Connector
6. Roof light
7. Switch
8. Traffic indicator switch
9. Left-hand blinker
10. Right-hand blinker
11. Blinker
12. Traffic indicator control light
13. Brake contact
14. Instrument lighting rheostat
15. Ammeter
16. "St" terminal
17. Fuel gauge
18. "Acc" terminal
19. "Am" terminal
20. Cigarette lighter (special model car only)
21. Ignition switch
22. Instrument lighting
23. Headlight control light
24. Door contact
25. Adjustable rheostat switches
26. Horn button
27. Heater
28. Defroster fan
29. Relay
30. Connectors
31. Fuse box
32. Dynamo
33. Foot dipper switch
34. Light switch
35. Connector
36. Fog lights, spot light reversing light
37. Battery
38. Starter motor
39. Order of firing
40. Horn
41. Ignition coil
42. Distributor
43. Horn (special model car only)
44. Connector
45. Relay
46. Headlights (dipped)
47. Headlights (full)
48. Parking lights
49. Left-hand headlight
50. Right-hand headlight

Grön = Green
 Svart = Black
 Röd = Red
 Vit = White
 Blå = Blue
 Grå = Grey
 Gul = Yellow
 Brun = Brown

Illustration X.

1. Right-hand stop and tail light
2. Left-hand stop and tail light
3. Number plate light
4. Connector
5. Switch
6. Fuel gauge tank unit
7. Roof light
8. Connector
9. Right-hand blinker
10. Traffic indicator switch
11. Blinker
12. Left hand blinker
13. Blinker control lights
14. Ammeter
15. Brake contact
16. Instrument lighting
17. Instrument lighting rheostat control
18. Cigarette lighter
19. Fuel gauge
20. Ignition and starter switch
21. "Am" terminal
22. "St" terminal
23. "Acc" terminal
24. Headlight control light
25. Door contact
26. Connectors
27. Horn button
28. Heater
29. Defroster fan
30. Foot dipper switch
31. Fuse box
32. Light switch
33. Charging relay
34. Dynamo
35. Connectors
36. Fog lights, spot light, reversing light
37. Battery
38. Starter motor
39. Order of firing
40. Horn
41. Ignition coil
42. Distributor
43. Connector
44. Relay
45. Horn (special model car only)
46. Headlights (dipped)
47. Headlights (full)
48. Parking lights
49. Right-hand headlight
50. Left-hand headlight
102. Rheostat switches

Svart=Black
 Grön=Green
 Orange=Orange
 Blå=Blue
 Röd=Red
 Grå=Grey
 Vit=White

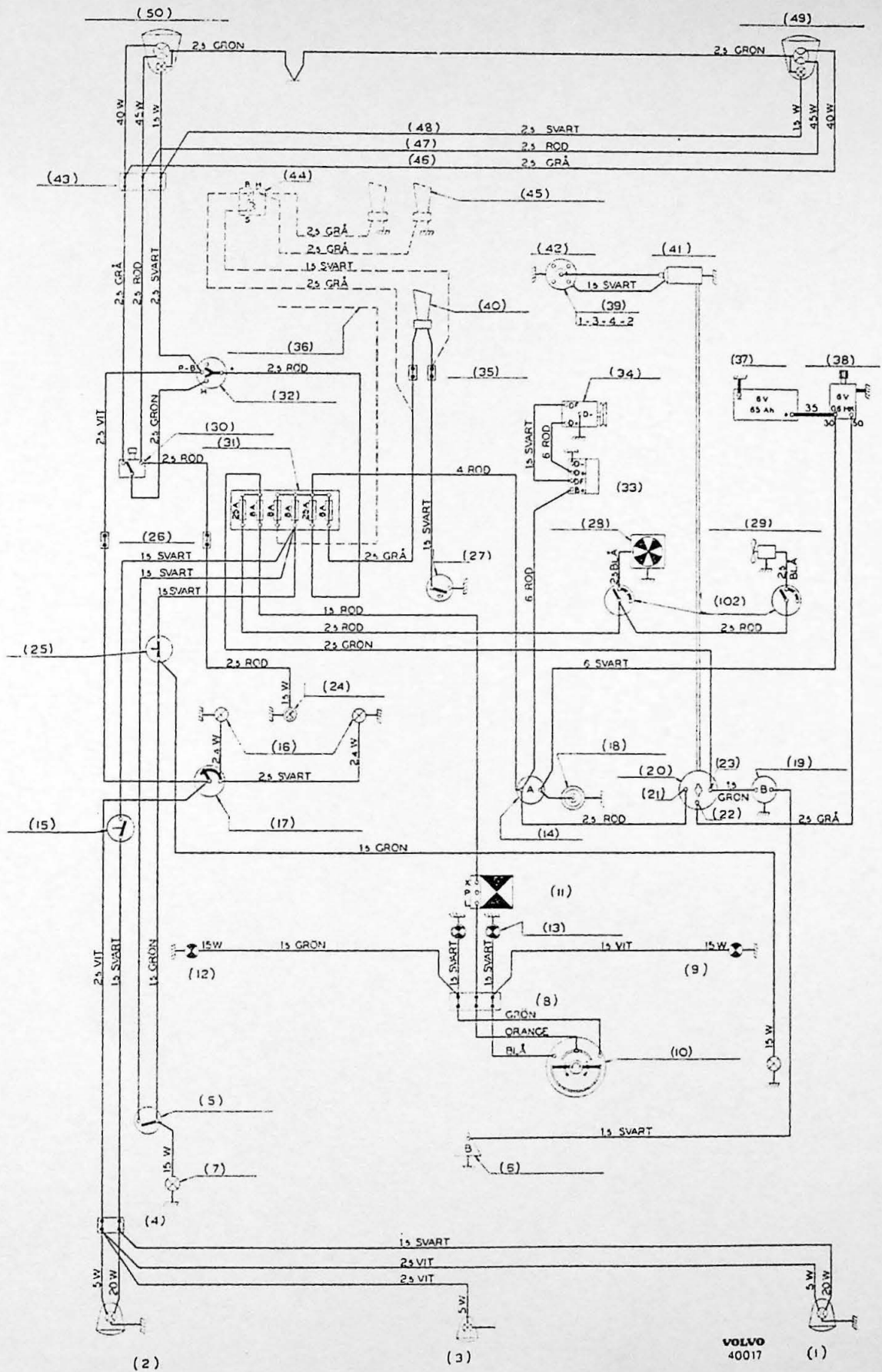

Illustration X. Electrical circuits for PV 444 E (late production).
 Chassis nos.: PV 444 E: 56005-68955

Illustration XI.

1. Left-hand stop and tail light
2. Right-hand stop and tail light
3. Number plate light
4. Tail light
5. Tail light
8. Stop and blinker light
9. Fuel gauge tank unit
10. Stop and blinker light
11. Roof light
12. Connector
13. Connector
14. Switch
15. Blinker
16. Ignition and starter switch
17. Traffic indicator switch
20. Right-hand blinker
21. Left-hand blinker
22. "Am" terminal
23. Instrument lighting rheostat control
24. Fuel gauge
25. "Acc" terminal
26. Blinker control lights
27. "St" terminal
28. Cigarette lighter
29. Ammeter
30. Instrument lighting
32. Door contact
33. Headlight control light
34. Regulator switch
35. Heater
36. Defroster fan
37. Regulator switch
38. Connector
39. Charging relay
40. Battery (6 V, 85 amp. hrs.)
41. Starter motor (6 V, 0.6 h.h.p.)
42. Dynamo
43. Connectors
44. Horn
45. Order or firing
46. Fuse box
47. Distributor
48. Ignition coil
49. Fog lights, spot light, reversing light
50. Horn button
51. Connector
52. Foot dipper switch
53. Lighting switch
54. Headlights (dipped)
55. Headlights (full)
56. Parking lights
57. Left-hand headlight
58. Right-hand headlight
59. Brake contact

Svart=Black
 Grön=Green
 Orange=Orange
 Blå=Blue
 Röd=Red
 Grå=Grey
 Vit=White
 Brun=Brown
 Gul=Yellow

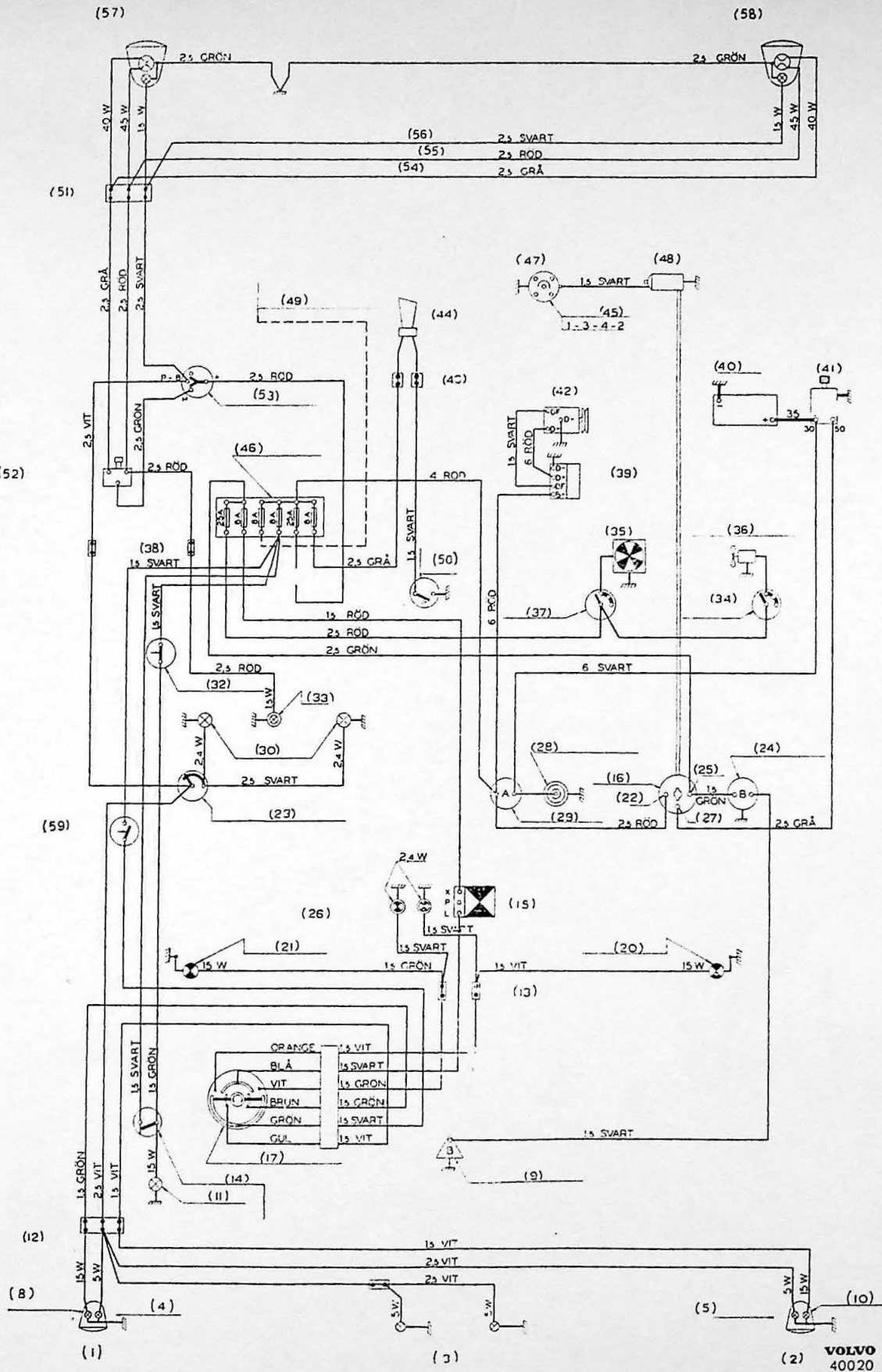

Illustration XI. Electrical circuits for PV 445 H and S (early production).

Chassis nos.: PV 445 DH: 1-796.
 PV 445 DS: 1-17.