

SERVICE MANUAL

CARS AND VANS

PV 444—445

Avd. 7

BRAKES

Export Service Department

AKTIEBOLAGET

VOLVO

GÖTEBORG . SWEDEN

DESCRIPTION

The PV 444 and 445 are fitted with two brake systems which are completely independent of each other. The one being the foot brake which is hydraulic and operates on all four wheels. The other, the handbrake, operates mechanically on both of the rear wheels.

The principle of the foot brake system is shown in Fig. 1.

When the brake pedal (11) is depressed it actuates the master cylinder (9) plunger (13) through the medium of a link rod (10) and push rod (12). Oil is thus forced to the wheel unit cylinders (2) through the line (6). The wheel unit cylinder plungers (5) then move outwards. Since the upper ends of the brake shoes (1 and 3) rest on the plungers, they are pushed out and the brakes are applied.

When the brake pedal is released the return spring (4) moves the brake shoes back to the rest position.

The handbrake, which is fitted to the left under the instrument panel actuates the rear wheel brake shoes through the medium of a lever and cable system.

There are two types of handbrake operating devices, one with a lever and ratchet and the other with a pull rod.

The brake handle (12 and 29 respectively, Fig. 2) movements are transmitted to the forward cable (49) through an intermediary lever (42), equalizing link (41) and the rear cable (32) to the lever (33) on the rear brake shoe. The upper end of this lever is attached to the rear brake shoe. When braking, the lever is drawn forward and pushes out the shoes through a link (1, Fig. 13) which is situated between the lever and the forward brake shoe.

The brake shoes are self-centring and the forward brake shoes of each wheel are self-adjusting.

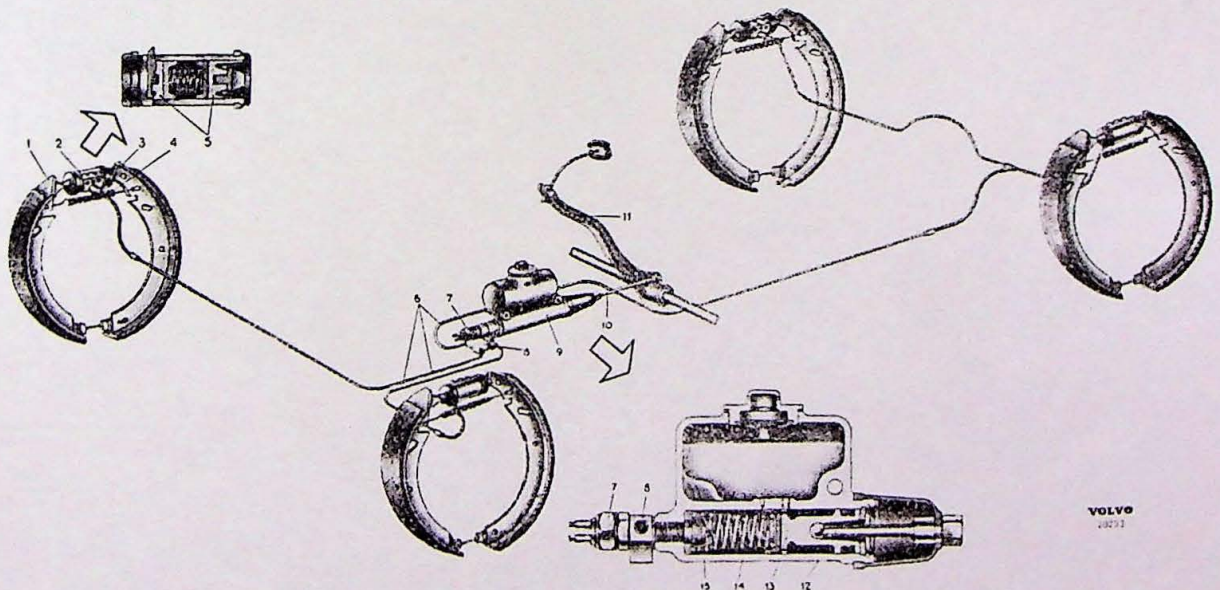

Fig. 1. Foot brake system.

- | | | |
|------------------------|-----------------------|-------------------|
| 1. Brake shoe, forward | 6. Brake lines | 11. Brake pedal |
| 2. Wheel unit cylinder | 7. Brake contact | 12. Push rod |
| 3. Brake shoe, rear | 8. Three-way junction | 13. Plunger |
| 4. Return spring | 9. Master cylinder | 14. Return spring |
| 5. Plunger | 10. Link rod | 15. Valve |

The **self-centring mechanism** is composed so that the bottom of the brake shoes (1, Fig. 3) are shaped as rounded projections (2) and rest against a support (3) which is attached to the backing plate.

When braking is applied the brake shoes will be centred in relation to the brake drum by a radial movement resulting in proper contact, efficient braking action and even lining wear.

The **self-adjusting mechanism** is only fitted to the forward shoes. The reason for this is that the rate of wear on the rear shoes is negligible. It is normally unnecessary to carry out any adjust-

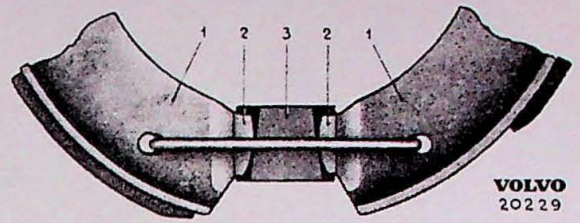

VOLVO
202 29

Fig. 3.

ments to the rear brake shoes before the linings are replaced. The self-adjusting mechanism is shown in Fig. 4.

A contact plug (7) is fitted in a hole in the brake shoe. The plug contacts the brake drum and is pressed against it by a spring (10).

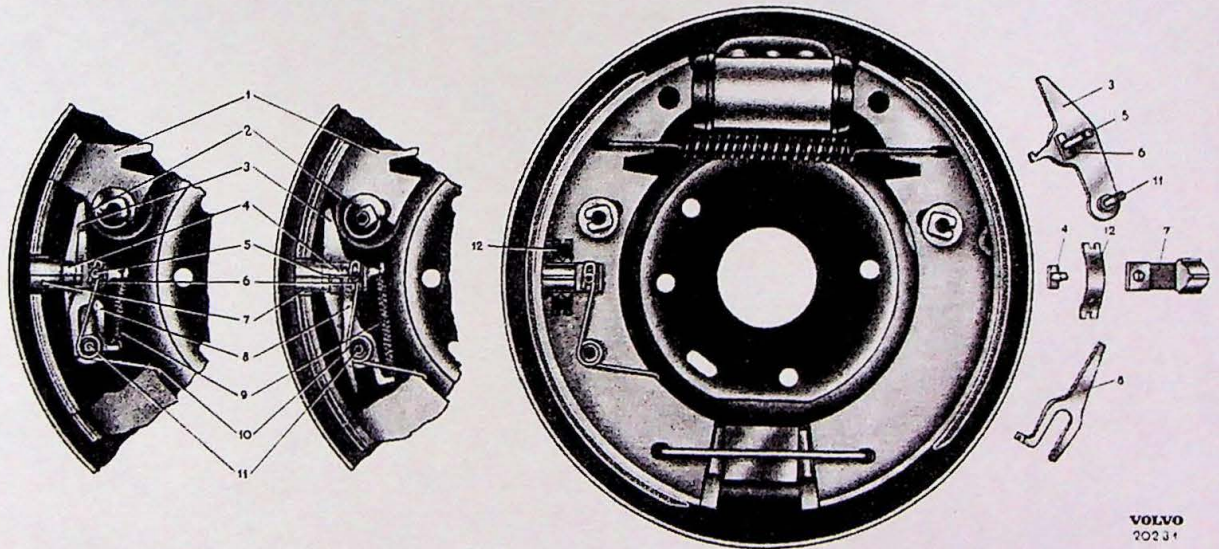

VOLVO
202 31

Fig. 4. Self-adjusting mechanism.

- | | | |
|---------------------|--------------------------|-----------------------------|
| 1. Brake shoe | 5. Bolt for contact plug | 9. Spring for key |
| 2. Eccentric | 6. Toothed projection | 10. Spring for contact plug |
| 3. Lever | 7. Contact plug | 11. Bolt |
| 4. Guide projection | 8. Key | 12. Damper spring |
-
- | | | |
|--------------------------------|---------------------------------|------------------------------------|
| 1. Rubber bushing | 18. Clamp | 35. Guide sleeve |
| 2. Clamp | 19. Rubber bushing | 36. Rubber cover |
| 3. Yoke | 20. Link for intermediary lever | 37. Support for brake cable |
| 4. Bolt | 21. Stop pin | 38. Return spring |
| 5. Bolt | 22. Return spring | 39. Bracket for intermediary lever |
| 6. Screw | 23. Pull rod | 40. Bolt for equalizer link |
| 7. Bolt | 24. Bracket for ratchet unit | 41. Equalizer link |
| 8. Ratchet | 25. Ratchet unit | 42. Intermediary lever |
| 9. Spring | 26. Ratchet ball | 43. Support for intermediary lever |
| 10. Screw | 27. Spring for ratchet ball | 44. Bolt for yoke |
| 11. Pull rod | 28. Lock pin | 45. Yoke |
| 12. Brake handle | 29. Handle | 46. Screw |
| 13. Rivet | 30. Brake drum | 47. Lock nut |
| 14. Pole lever | 31. Spring for lever | 48. Tension sleeve |
| 15. Forward intermediary lever | 32. Cable, rear | 49. Cable, forward |
| 16. Bolt | 33. Lever | 50. Attaching clamp |
| 17. Yoke | 34. Lock washer | |

The contact plug moves continuously in as the brake lining wears down. The inward movements of the plug influences the eccentric (2) through the medium of a bolt (5), a lever (3) which is pressed against it. The distance between the guide projection (4) and the toothed projection (6) on the lever (3) is then increased. The toothed key (8) which is actuated by a spring (9), is then drawn in between the above-named projections (4 and 6). The brake shoe return movement is thus restricted and the clearance between the brake linings and drums will be unchanged.

Self-adjustment ceases when the lining wears out and the contact plug reaches the contact surface between the brake shoe and the lining. This will result in increased clearance and pedal free play and thus make plain the fact that the brake lining should be replaced.

A damper spring (12) is fitted between the brake shoe and the contact plug to prevent the latter from vibrating. The early production self-adjusting mechanism contact plug spring (10) consists of a coil spring fitted in the contact plug.

REPAIR INSTRUCTIONS

Overhauling the hydraulic system

Master cylinder

The master cylinder is removed by removing the protector plate, disconnecting the brake contact cable and the brake line connections at its forward end. Disconnect the push rod from the brake pedal. Unscrew the two bolts which attach the master cylinder to the body (the frame on the PV 445) and lift it off.

Clean the master cylinder with the jet of compressed air. Remove the filler plug and drain off the oil.

Disassembling the master cylinder

1. Loosen the master cylinder rubber cover (1, Fig. 6) and remove the push rod (2) and rubber cover.
2. Remove the lock ring (3) and stop washer (4) for the plunger (7).
3. Take out the plunger, gasket (8), return spring (9), valve (10) and gasket (11). On late production models (from chassis no. 6141 onwards) the valve is attached to the return spring.
4. Remove the three-way junction (16) and the brake contact.

When the master cylinder has been assembled all components should be cleaned in methylated spirit.

N.B. Wash your hands in soap and water before cleaning the components.

All parts should be inspected after they have been cleaned. Check that the cylinder is not scratched, that the gaskets are not faulty and that

the valve is not damaged. Worn or damaged parts and swollen gaskets should be replaced.

The clearance between the plunger and cylinder should be between .001"—.005" (0,025—0,127 mm) and should be measured as shown in Fig. 5.

If the clearance exceeds .005" the plunger must be replaced.

The return spring should have an unloaded length of 75 mm (2 15/16").

Assembling the master cylinder

Before assembling check that both of the holes (1 and 2, Fig. 7) which connect the oil reservoir to the pump cylinder are open. At the same time check that the penetrating holes (3) in the plunger are free from dirt.

Rinse the components in methylated spirit when they are assembled.

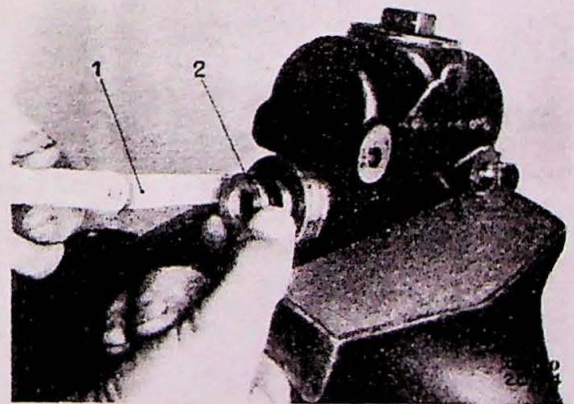

Fig. 5.

1. Feeler gauge 2. Plunger

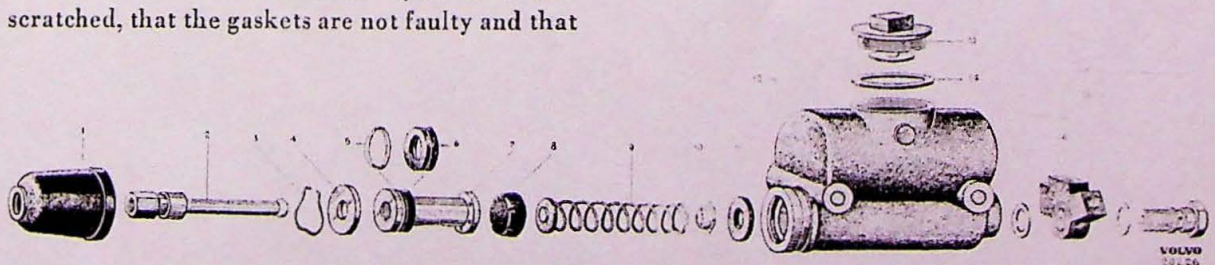

Fig. 6. Master cylinder.

- | | | | |
|------------------------------|-----------------------------|----------------------|---|
| 1. Rubber cover | 6. Gasket, rear | 11. Gasket | 16. Three-way junction |
| 2. Push rod | 7. Plunger | 12. Master cylinder | 17. Bolt for three-way junction and brake contact |
| 3. Lock ring | 8. Plunger gasket | 13. Cover | 18. Gasket |
| 4. Stop washer | 9. Return spring and washer | 14. Gasket for cover | |
| 5. Lock ring for rear gasket | 10. Valve | 15. Gasket | |

1. Fit the gasket (11) in the pump cylinder and then the valve and return spring (10 and 9).
2. Fit the rear gasket (6) and lock ring (5) on the plunger (7) and push the plunger gasket (8) and plunger into the cylinder. Fit the stop washer (4) into place and then fit on the lock ring (3).
3. Put the push rod (2) in the plunger (7) and pull the rubber cover (1) over the projection on the master cylinder.
4. Fit on the three-way junction (16) with the brake contact.
5. Check that the plunger gasket (8) does not obstruct the equalizer hole (1, Fig. 7). Push a piece of wire through the hole for the filler cap and equalizer hole. It should then be possible to push in the plunger about 0,2—0,3 mm (.008"—.012").

The master cylinder is fitted in the opposite way to that used when it was removed. Con-

cerning the filling of brake fluid, see under the heading "Air-venting the brake system".

Wheel unit cylinders

The wheel unit cylinder is accessible when the wheel, hub and brake shoes have been removed. Use puller SVO 1446 for front and rear wheel hubs fitted with four bolts. SVO 4011 can also be used for the front wheel hubs with four bolts. SVO 1791 should be used for front and rear hubs fitted with five bolts. If the bearing race and seal ring should not come off with the hub, the race can be pulled off with SVO 4016 if the hub is fitted with four bolts and SVO 1794 if it is fitted with five. Concerning the removal of the brake shoes, see page 9.

The wheel unit cylinder is removed when the brake hose connection is disconnected by unscrewing the two attaching bolts in the protector plate (2, Fig. 9).

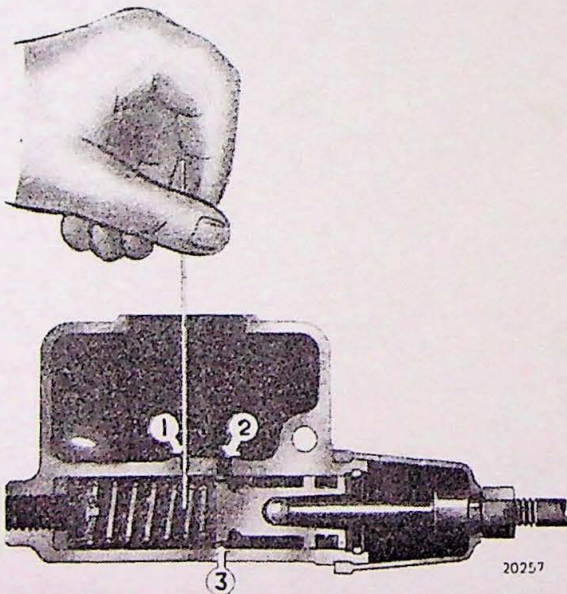

Fig. 7.

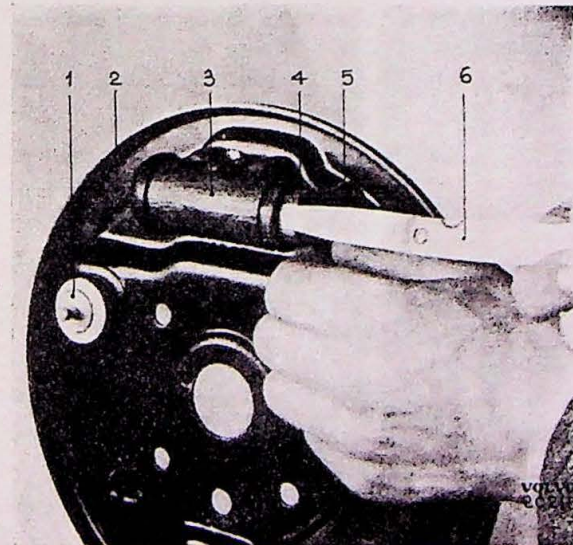

Fig. 9.

- | | |
|------------------------|----------------------|
| 1. Eccentric | 4. Plunger with stud |
| 2. Backing plate | 5. Rubber cover |
| 3. Wheel unit cylinder | 6. Feeler gauge |

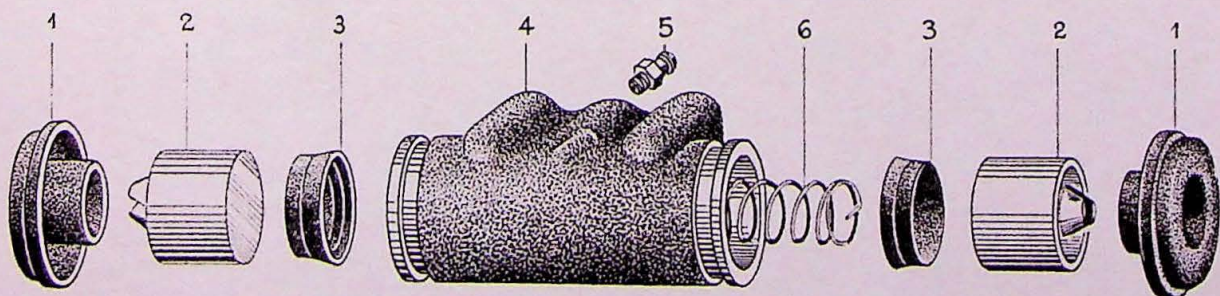

Fig. 8. Wheel unit cylinder.

- | | | |
|----------------------|------------------------|----------------------|
| 1. Rubber cover | 3. Gasket | 5. Air-venting valve |
| 2. Plunger with stud | 4. Wheel unit cylinder | 6. Spring |

VOLVO
20225

Before commencing disassembly, any dirt must be blown off the unit with a jet of compressed air. Loosen the two rubber covers (1, Fig. 8) and then take out the plungers and stud (2) from the wheel unit cylinder (4). Remove the rubber gasket (3) and spring (6) from the cylinder by applying a light pressure at one end.

The wheel unit cylinder components should be examined concerning damage and wear. Damaged or worn parts and swollen gaskets must be replaced. The clearance between the plunger and cylinder should not exceed .005" (0,127 mm). On the other hand the clearance should not be less than .001" (0,025 mm). Measuring should be carried out as shown in Fig. 9.

Fitting should be carried out in the opposite order to that used for removing. All parts should be rinsed in methylated spirit before they are fitted.

Brake lines

The hydraulic brake system lines should be rinsed when the master cylinder or the wheel unit cylinders are overhauled or on other occasions when this is deemed necessary.

The lines should be disconnected at the wheel unit cylinders one at the time and rinsed with methylated spirit. Carry out the rinsing by filling the master cylinder with methylated spirit and depressing the brake pedal several times. Fill the master cylinder with clean brake fluid and flush the lines until they are free from methylated spirit. Make sure that the lines are free from all spirit as otherwise it will cause vapour bubbles to appear in the system and result in a "spongy" pedal.

Should leakage occur or if any of the lines should become damaged in such a way that the risk of leakage is prevalent, the damaged lines

must be replaced. Replacement should be carried out in the following way:

1. Remove the damaged brake lines.
2. Cut-off the new line to the required length (see "Specifications"). The line should be cut at right angles and all burr removed.
3. If the line is made of copper it should be flanged in the normal way but if it should be of steel piping it should be double flanged with SVO 2049. Fit the tool in a vice. Push in the piping until it is flush with the back of the clamp as shown in Fig. 10. Tighten the nuts.
4. Place drift OP 1 into the tool. Hit the drift with a copper hammer until it bottoms. The edge of the piping will then be bent as shown in Fig. 12.
5. Replace the drift with OP 2 (Fig. 12) and hit the drift until it bottoms.
6. Screw on the connecting nuts and repeat operations 3 and 5 on the other end of the pipe.

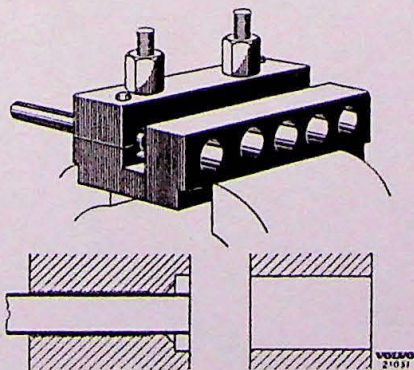

Fig. 10.

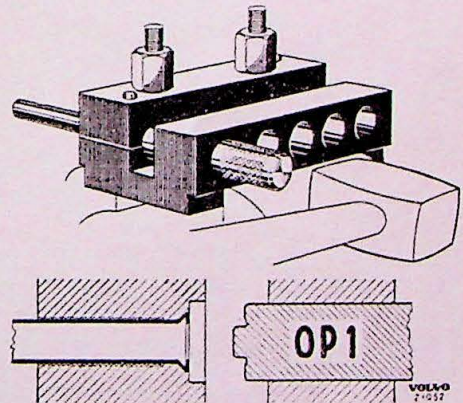

Fig. 11.

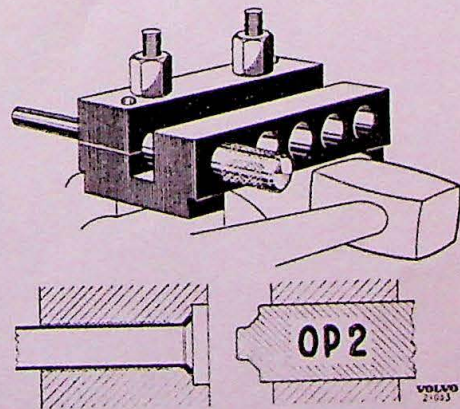

Fig. 12.

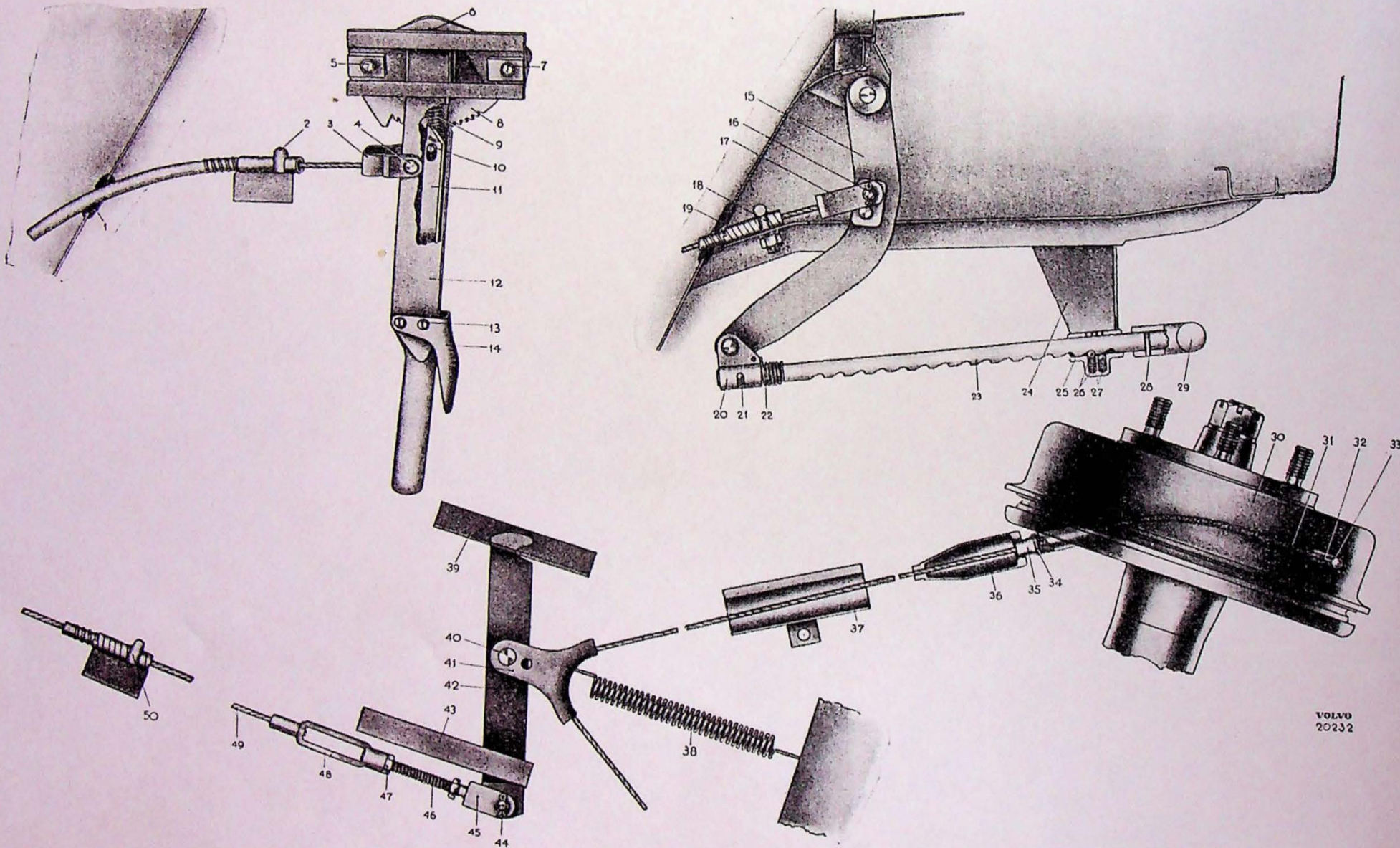

Fig. 2. Handbrake system.

VOLVO
20232

7. Bend the new brake line so that it corresponds with the old. The line is bent round an object with the same radius as the required arc.
8. Clean the line internally with a jet of compressed air and fit it into place.

N. B. Rubber parts must not be cleaned with petrol or paraffin. Use only top quality brake fluid as specified according to SAE 70 R 1 (HD-quality).

Try to avoid spilling any of this fluid on the metal parts of the vehicle as it can damage the paintwork.

Overhauling the handbrake system Replacing the rear cable

Removal

1. Release the handbrake and block up the rear axle.
2. Disconnect the return spring (38, Fig. 2) and remove the bolt (40) for the equalizer link (41).
3. Loosen the rear wheels and pull off the brake drums with the hubs. Use SVO 1446 A for wheels fitted with four bolts and SVO 1791 for wheels fitted with five.
4. Disconnect the cable (3, Fig. 13) from the lever (2) on the rear brake shoe.
5. Remove the rubber cover (5) from the pipe flange on the backing plate.
6. Drive in the guide sleeve (35, Fig. 2) with a thin drift and remove the lock washer (34). It is now possible to pull out the cable

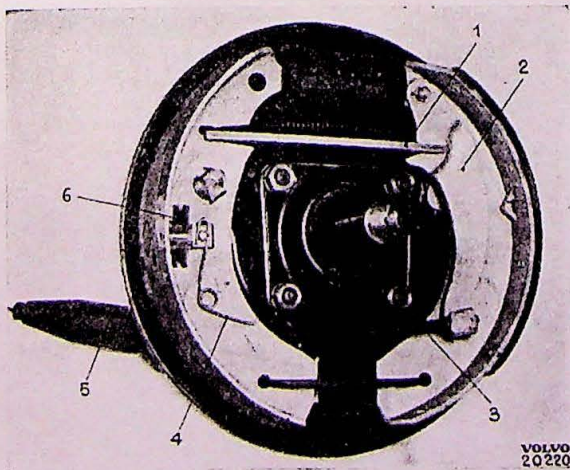

Fig. 13.

- | | |
|----------|----------------------------|
| 1. Link | 4. Spring for contact plug |
| 2. Lever | 5. Rubber cover |
| 3. Cable | 6. Damper spring |

together with the guide sleeve and spring (31) through the pipe in the backing plate.

Fitting

1. Readjust the screw (46, Fig. 2) with the tensioner sleeve (48). Put the cable into the equalizer link (41) and attach it to the intermediary lever (42).
2. Push the cable and the guide sleeve through the support (37) and then continue pushing it through the pipe in the brake backing plate. Fit the lock washer (34) and push the guide sleeve into position, see Fig. 2. Attach the cable to the lever.
3. Pull on the rubber cover (36). Fit on the brake drum together with the hub and wheel.
4. Adjust the handbrake. See page 13.

Replacing the rubber cover

If the rubber cover on the brake backing plate has become damaged in any way it must be replaced. Otherwise water and dirt can penetrate to the brake shoes.

For this replacement there is a special rubber cover with a seal plug (part nos. 86850 and 86851 respectively).

Disconnect the wheel and brake drums together with the hub. Disconnect the cable from the lever. Pull off the rubber cover, remove the lock washer and pull out the cable. (See under the heading "Replacing the rear cable"). Remove the old rubber cover.

The new cover should be pushed over the spring on the brake cable which should be pushed into the backing plate. Fit the lock washer and attach the wire to the lever.

The slotted seal plug (1, Fig. 14) should be put on the cable (2) and then pushed into the rubber cover (3).

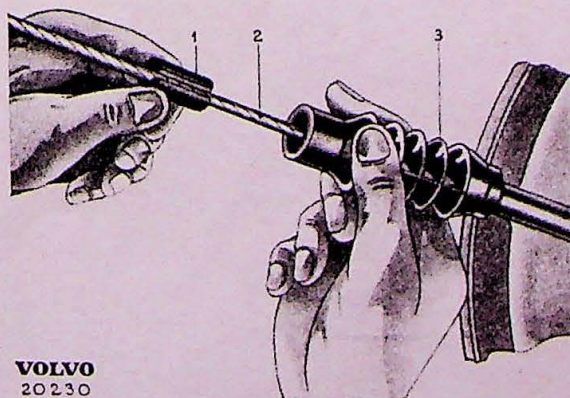

Fig. 14.

Fit on the brake drum together with the hub and wheel.

Replacing the forward cable

1. Remove the bolt (44, Fig. 2) which attaches the yoke (45) to the intermediary lever (42) and disconnect the lower attaching clamp (50).
2. Release the clamp (2 and 18) for the cable and remove the yoke bolt (3 and 17) on the handbrake lever (12) and forward intermediary lever (15) respectively.
3. Pull out the cable and unscrew the yoke and bolt from the tensioner sleeve (48).
4. Attach the yoke to the tensioner sleeve on the new cable. Push the cable into position and tighten the clamp and attaching clamp. Attach these to the handbrake lever and forward intermediary and intermediary levers (42) respectively.
5. Adjust the handbrake, see page 13.

Replacement of push rod and quadrant (lever type handbrake)

Removal

1. Remove the left-hand glove-box cover.
2. Remove the bolt (4) for the yoke (3) attachment on the handbrake lever.
3. Unscrew the two bolts (5 and 7) that attach the quadrant (8) and lift out the lever and quadrant.
4. Unscrew the bolt (6) which holds the lever and quadrant together. Disconnect the spring (9).
5. Grind off the head of the rivet (13) which connects the push rod (11) and handle (14). Drive out the rivet. Remove the pull rod bolt (10).

Fitting

1. Push in the push rod into the handbrake lever and rivet them together so that the handle is movable in all positions. Screw in the bolt at the other end of the push rod.
2. Fit the lever to the quadrant and connect the spring.
3. Screw the quadrant into its position. Connect the cable yoke to the handbrake lever.

Replacement of pull rod and ratchet (pull rod type)

1. Disconnect the pull rod (23), return spring (22) and drive out the stop pin (21) on the intermediary lever (20) link.

2. Release the interlock ball sleeve (25) from the bracket (24) and take out the pull rod and interlock ball sleeve.
3. Remove the return spring and ball sleeve from the pull rod. Drive in the pull rod pin (28) and pull off the handle.
4. Fit the handle onto the new pull rod and drive in the pin until it is flush with the handle.
5. Fit a new spring and ball into the ball sleeve and push it onto the pull rod and return spring.
6. Push the pull rod into the intermediary lever link and drive in the stop pin. Connect the return spring.
7. Screw the interlock ball housing into the bracket.

Brake shoes

Removal from the brake backing plate

Remove the brake shoes when the wheel and hub have been taken off.

Release the wheel nuts with a wheel bolt wrench.

Jack up the vehicle and block up the link arm for the front wheel or the rear axle if the rear wheel is to be removed. Take off the wheel and cap nut. Remove the front wheel lubricating cap with SVO 2197. Pull off the hub with SVO 1446 A. SVO 1791 should be used for hubs fitted with five wheel bolts. See Fig. 15.

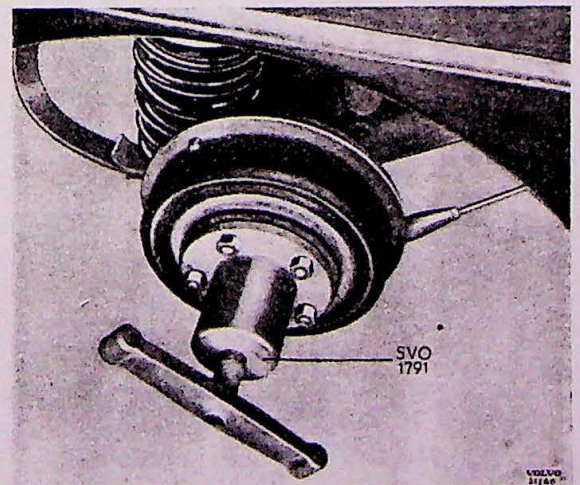

Fig. 15.

If the front wheel in the bearing race should not come out with the hub, pull it out with the SVO 4016 if the hub has four bolts or SVO 1794 if it has five. See Fig. 16.

1. Remove the spring (1, Fig. 17). Use tool SVO 1221.
2. Fit clamp SVO 4074 so that the thrust plugs are prevented from being pushed out, see Fig. 18.

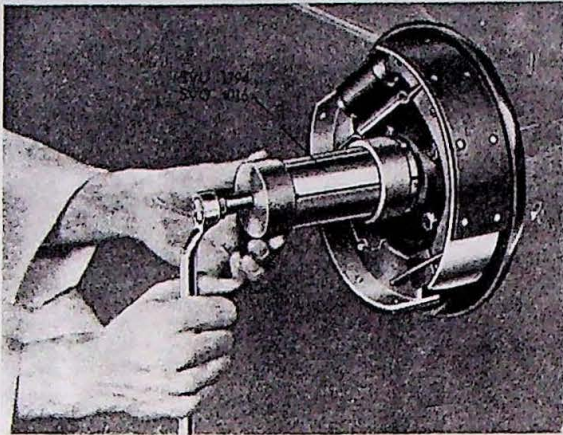

Fig. 16.

VOLVO
21882

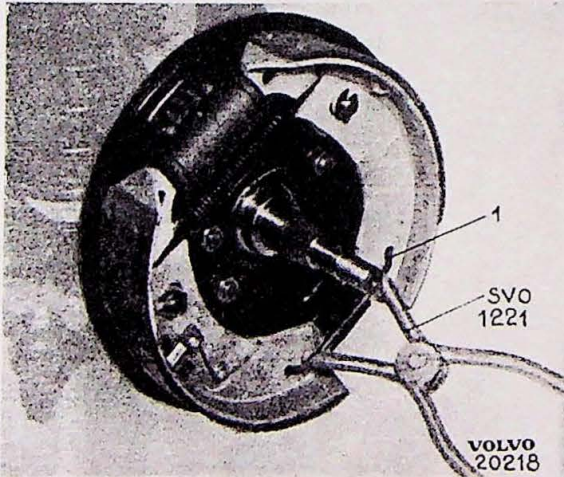

Fig. 17.

VOLVO
20218

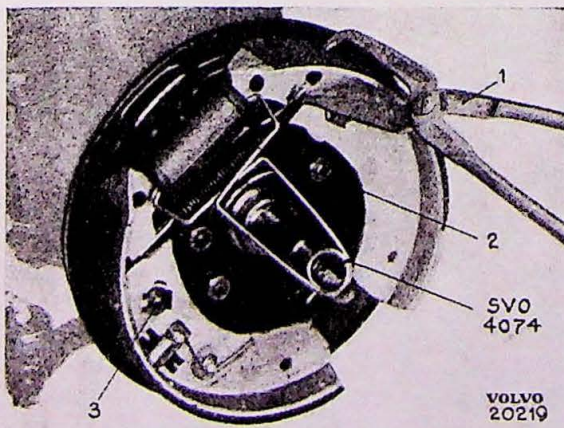

Fig. 18.

VOLVO
20219

3. Disconnect the return spring (2) by using a brake spring plier (1) of the larger type.
4. Remove the lock for the eccentric (3) and lift the shoes off the backing plate. When disassembling the rear wheel brakes first move the lever (2, Fig. 13) forward and disconnect the cable (3).

Disassembling the self-adjusting device

1. Press in the contact plug (7, Fig. 4) and make sure that the key (8) is in its correct position (see left-hand figure).
2. Disconnect the key spring (9) and the contact plug spring (10) (late production).
3. Remove the lever (3), key (8), contact plug (7) and damper spring (12) as well as the guide projection (4) from the brake shoe.

Brake lining replacement

The late production model of the PV 444 and 445 are fitted with bonded brake linings. It is possible to fit this type of brake lining on early production models provided that they are fitted so that each axle has linings of the same type on each side. Otherwise the brakes can easily give uneven application.

The brake lining should be replaced as follows.

Early production (riveted)

Take off the old lining by pushing up the rivets in a rivet press. Clean the brake shoes and self-adjusting device components in clean petrol and dry them with compressed air.

When fitting a new brake lining check that it is of the correct size. The hole in the forward lining should have a diameter of 19 mm ($\frac{3}{4}$ "). See the "Specifications".

Start riveting in the centre of the lining and make sure that it contacts the brake shoe along its entire length. Use a rivet press and a rivet driver suitable for the size of rivet. The rear lining (short lining) should be fitted onto the upper section of the shoe (see Fig. 4).

Late production (bonded)

The best way to remove the old lining is with a lining grinder. They can also be chiseled off and the brake shoes afterwards polished with emery cloth. With both of these methods care must be taken not to damage the brake shoes.

After grinding, the brake shoe should be cleaned with petrol, or something similar, and left to

dry. When this has been carried out the contact surface for the lining must not come in contact with nor be allowed to become dirty.

The size of the new brake linings are listed in the "Specifications" on page 17. Check, when fitting, that the lining does not lay askew on the brake shoe and that the hole in the forward lining is immediately over the contact plug. The rear lining is fitted onto the upper section of the brake shoe.

Only use adhesive of a type specially manufactured to tolerate the high temperatures which occur with continuous braking. The method of adhesion varies with the different types of adhesive and different methods of stoving whereupon it is impossible for us to give a general description. Follow carefully the manufacturer's recommendations.

Assembling and testing the self-adjusting device

The contact plug, which is made of metal to obtain a minimum of friction, can be worn to a certain extent without the brake drum being damaged. However, the plug must always be replaced at the same time as the lining.

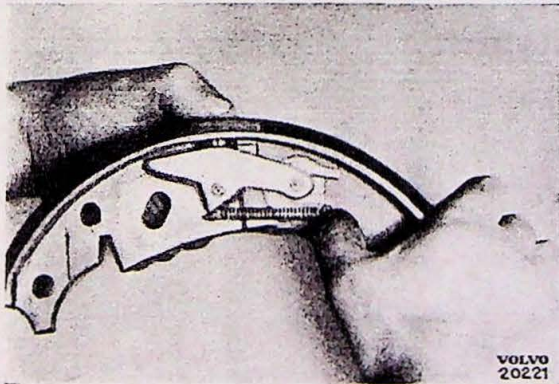

Fig. 19.

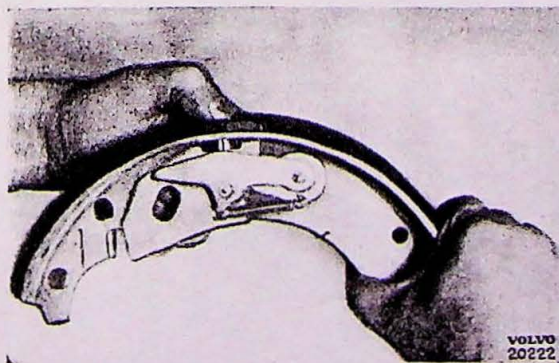

Fig. 20.

The new contact plug is fitted in the brake shoe when the guide projection (4) has been fitted. Do not forget the spring when fitting early production contact plugs. Put the key (8) into position with the smooth side against the guide projection. Press in the contact plug until its hole is in line with the brake shoe hole. Fit the lever (3) and contact plug (10) spring (lever lock on early production models). Connect the key spring (9) and fit the damper spring (12).

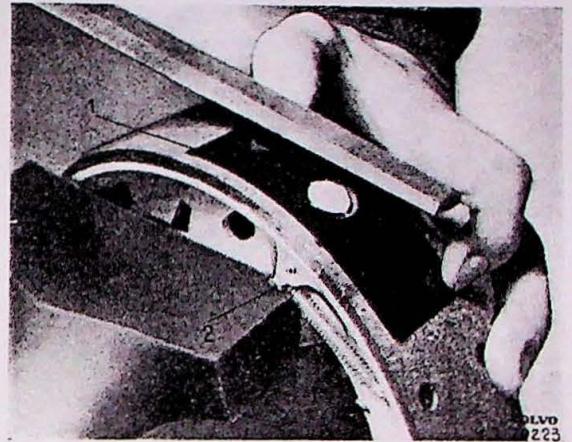

Fig. 21.

The self-adjusting mechanism should then be tested as follows: Move the wedge over to the end position while the contact plug is held down, see Fig. 19, then ease the pressure and release the key, the spring should be strong enough to move the key inwards when the contact plug is pushed down again, see Fig. 20. When the retained pressure moves the key back to the outer position the brake shoe is ready for contact plug adjustment.

Adjusting the contact plug

The contact plug is adjusted with the aid of a file and an adjuster jig made especially for this purpose (part no. 210030).

With the contact plug in its outer position fit the brake shoe in a vice with the lever projection (2, Fig. 21) resting against one vice jaw. This is to ensure that the plug cannot be pushed in during adjustment and in this way cause it to be faulty.

Place the adjuster jig (1) over the contact plug and then file until the plug is flush with the jig, see Fig. 21. The plug should then be 0.1 mm (.04") over the surface of the lining.

Adjusting the brake shoes

The brake shoes should be fitted in the opposite order to that used when they are removed. Check that the key is in the outer position and the eccentric on the brake backing plate is turned to the lowest position.

Under no circumstances whatsoever must the self-adjusting device or the brake shoe surface against the studs and centring projection be lubricated. Lubricant can run down onto the brake linings or drum and completely ruin the braking effect. Dust from the brake linings or dirt may adhere to the self-adjusting and self-centring devices and disturb the operation.

Clean and inspect the hub and brake drum before they are fitted. Replace the drum if it is cracked or heavily scratched by the rivets.

Brake backing plates

Replacement of adjuster cam bolt

The bolt (5) for the backing plate adjuster cam (4) can be replaced by driving out the damaged bolt and staking a new bolt with staking tool SVO 2119 which is manufactured especially for that purpose.

The bolt should be replaced in the following way:

1. Place the staking tool base sleeve in a press,

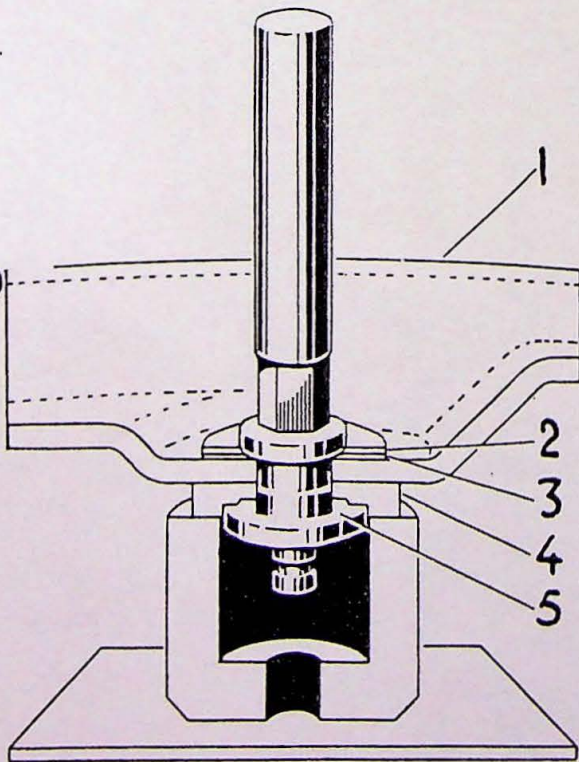

Fig. 22.

VOLVO
21281

as shown in Fig. 22, and drive out the bolt (5) with the drift.

2. Invert the base sleeve and put the new bolt on top of it. Fit the adjuster cam (4), backing plate (1), base washer (3) and the sprung internally-toothed washer (2) onto the bolt. Stake the bolt with the staking tool, see Fig. 23.

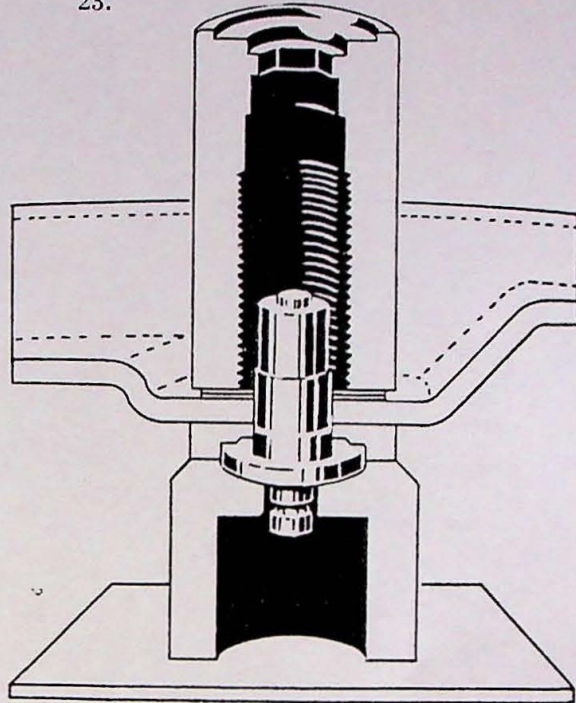

Fig. 23.

VOLVO
21282

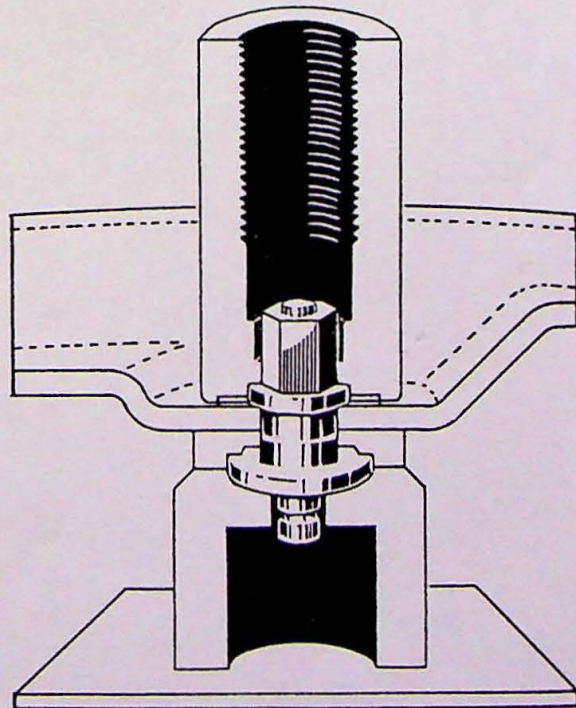

Fig. 24.

VOLVO
21283

3. Invert the tool and centre it on the bolt. Check that it comes in line with the bolt. Stake with the tool, see Fig. 24. Stop staking when a maximum pressure of 8 tons is reached. Twist the tool and check that the bolt does not move too easily. If this should be the case apply a little more pressure.
4. Put in the screw and pull the tool off the bolt, see Fig. 25.

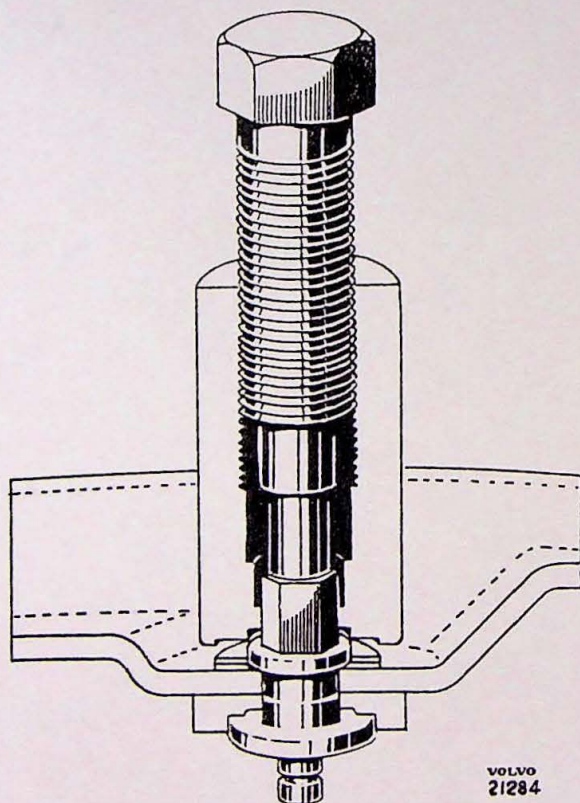

Fig. 25.

Adjusting the brakes

Adjusting the brake shoes

Make sure that the handbrake is released. Rotate the wheel backwards and turn the forward brake shoe eccentric away from the wheel unit cylinder until the wheel is locked by the brake shoe. Loosen the eccentric enough so that the drum can easily be turned (see 2, Fig. 26). Adjust the rear brake shoe in the same manner. The wheel should then be rotated in the forward direction and the eccentric turned from the wheel unit cylinder when taking up (see 1, Fig. 26).

Adjusting the brake pedal free play

It is imperative that the brake pedal has the correct free play. If this is insufficient the equalizer hole (1, Fig. 7) between the pump cylinder

and the oil reservoir can be blocked by the plunger gasket which result in that the brake shoes are prevented returning to their rest position.

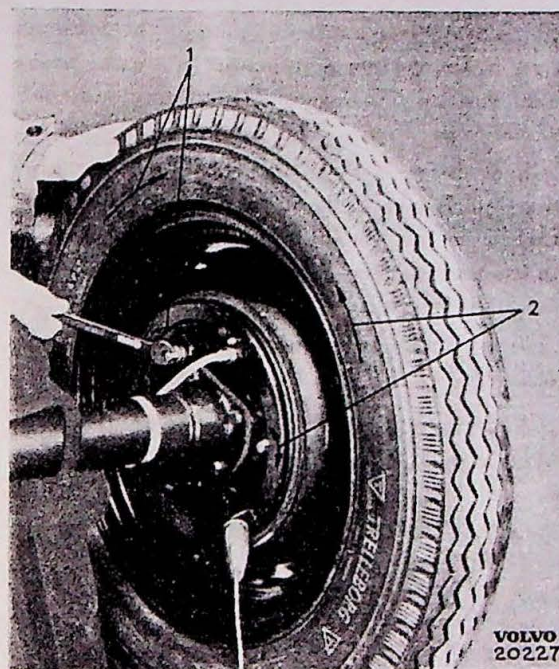

Fig. 26.

If the pedal free play is excessive it can result in an insufficient effective stroke making pumping necessary to obtain the braking effect required. The brake pedal free play adjustment should be carried out by adjusting the link rod (10, Fig. 1) length. Loosen the lock nuts and then loosen the link rod by the pedal. Screw the link rod in or out until the pedal has a free play of 7—12 mm ($\frac{1}{4}$ — $\frac{1}{2}$ "). Tighten the lock nut and lock the push rod at the pedal.

Adjusting the handbrake

There are two ways in which the handbrake can be adjusted. This can be carried out either by stretching the forward brake cable by means of the screw (46, Fig. 2) at the tensioner sleeve (48), or by moving the equalizer link (41) for the rear cable forwards. The later method should be used when the screw (46, Fig. 2) is screwed entirely into the sleeve. This should be carried out as follows: Unscrew the screw a number of turns and fit the bolt in the rear hole in the equalizer link. Readjust with the screw until the handbrake gives full braking effect at the 6—8 notches in the quadrant.

Do not forget to lock the bolt (40) or to tighten the lock nut (47) on the tensioner sleeve (48).

Air-venting the brake system

The brake system should always be air-vented when a brake line has been opened. The presence of air in the system is indicated when the brake pedal can be depressed without any noticeable resistance or when it feels "spongy".

Check, before air-venting, that the brake shoes are properly adjusted and that there is sufficient brake fluid in the container. If the fluid level is too low there is a risk that air may penetrate into the system again.

Use a special filler bottle when filling brake fluid, see Fig. 27.

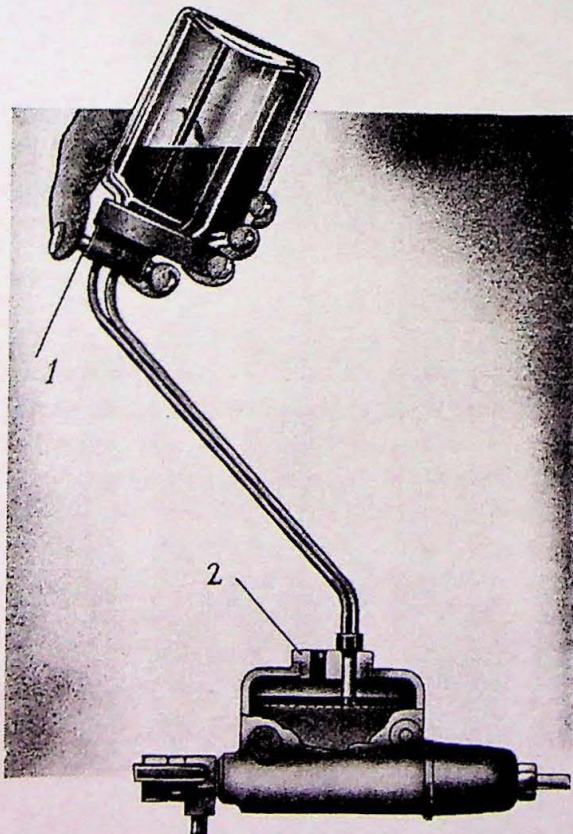

Fig. 27.

VOLVO
20139

Start air-venting at the left-hand front wheel and then the right-hand front wheel, left-hand rear wheel and right-hand rear wheel by turns.

Air-venting should be carried out as follows:

1. Clean the area around the filler cap and air-venting nipples.
2. Remove the master cylinder cover. Use spanner SVO 1457 on models A and B cars, from

model C cars onwards use a box spanner (1 1/8") and a long extension. Top-up with more brake fluid if necessary. It is advantageous to use a special filler bottle.

3. Fit on spanner SVO 1431 B with the air-venting hose on the nipple and let the other end of the hose hang down in the collecting jar, see Fig. 28.
4. While somebody is pressing down the pedal slowly the valve should be opened with the key and held open as long as there are air bubbles in the fluid.

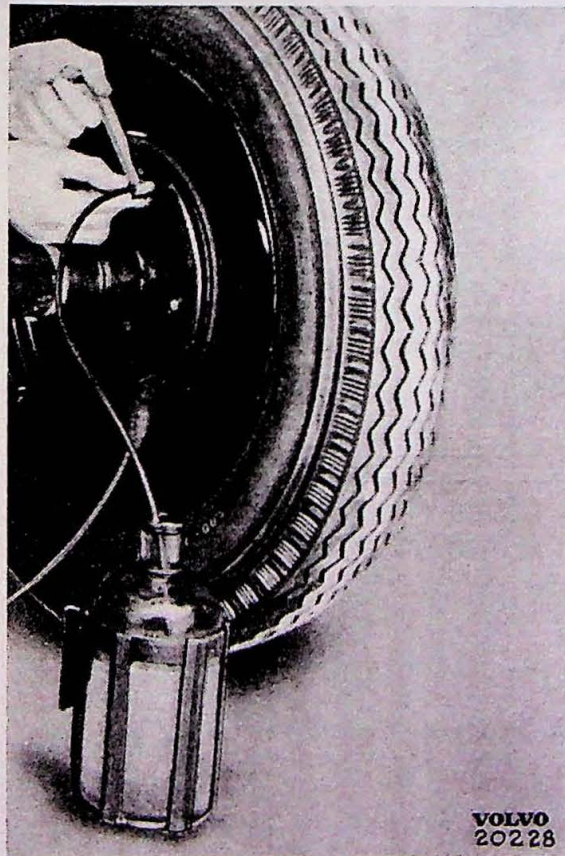

Fig. 28.

5. Air-vent the other wheels in the same way and then fill the container. Check the gaskets and screw in the cap.

Use the filler bottle as shown in Fig. 27 keeping the fluid level constant and at the right level. It should be used as follows: Screw in the plug (2) in the cover opening. Push the pipe through one of the holes in the plug and open the cock (1). When air-venting is finished close the cock and remove the bottle and plug.

TRACING FAULTS

FAULT	
REASON	REMEDY

Poor braking effect in spite of the pedal being fully depressed

<p>Excessive pedal free play. Insufficient fluid in the brake system.</p> <p>Air in the brake lines. Grease or oil on the brake lining.</p> <p>Worn brake lining. Uneven brake adjustment (the self-adjusting mechanism does not function on one or more wheels).</p>	<p>Adjust the free play. Top-up with brake fluid and air-vent the brake system.</p> <p>Air-vent the brake system. Replace the brake lining, check and, if necessary, replace the seal ring. Replace the brake lining. Adjust the brake. (Remove the wheel, hub and brake drum and examine the self-adjusting device).</p>
---	---

The car pulls to one side when braking

<p>There is grease or oil on one of the brake linings. Brake shoes are unevenly adjusted.</p> <p>Out-of-round or uneven brake drum. Faulty tyre pressure.</p>	<p>See above. Adjust and if necessary check the self-adjusting device. Replace the brake drum. Inflate the tyres to the correct pressure, see part 8.</p>
---	---

Brakes dragging on all wheels

<p>Brake shoes faultily adjusted. The brake pedal has insufficient free play, equalizer hole blocked. Equalizing hole between the cylinder and the container is blocked by dirt.</p>	<p>Adjust all brake shoes. Adjust the pedal free play. Disassemble and clean the master cylinder.</p>
--	---

Brakes drag on one wheel

<p>Brake shoes are faultily adjusted. Weak or broken return spring. Wheel unit brake line is damaged or blocked.</p>	<p>Adjust the brake shoes. Replace the spring. Replace the damaged line. Flush out or replace a blocked line.</p>
--	---

TOOLS

The following tools should be used when carrying out any repairs on the brake system.

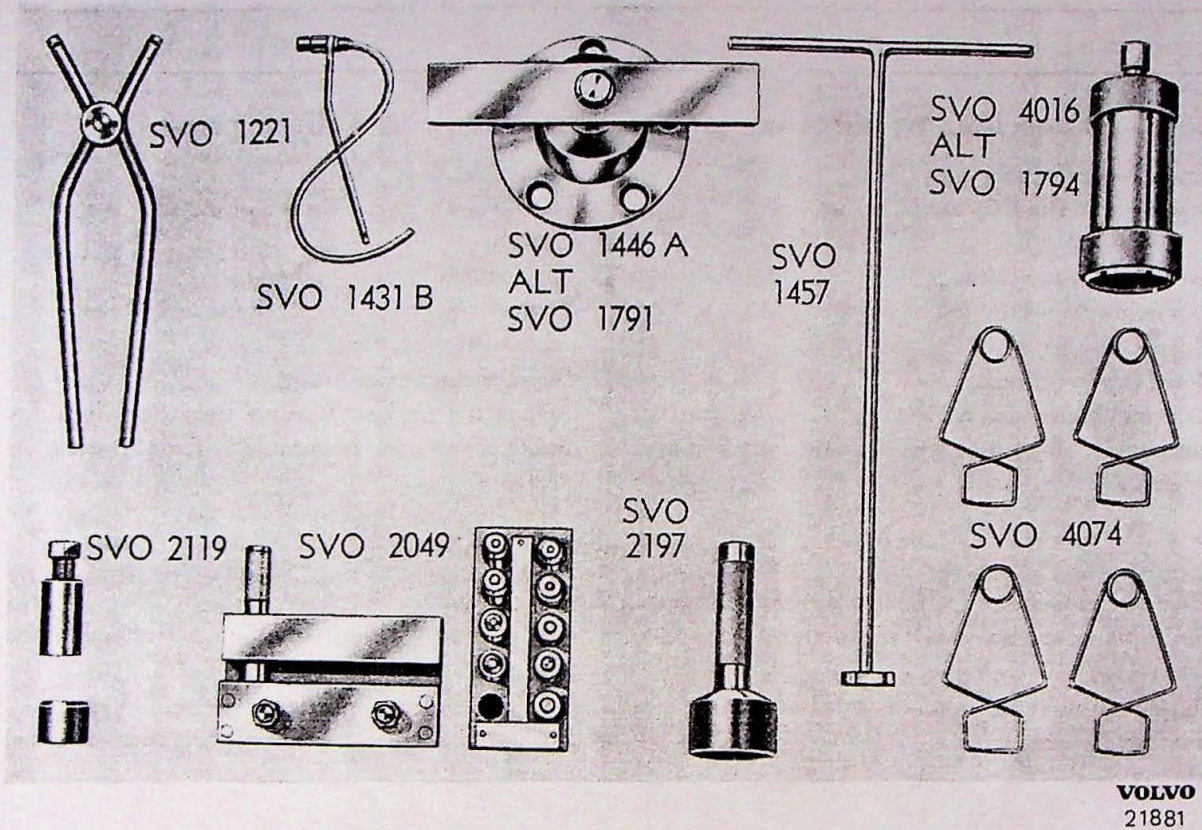

VOLVO
21881

SVO 1221 Tool for removal and fitting of the lower brake spring.

SVO 1431B Spanner for air-venting screw.

SVO 1446A Puller for hubs with brake drums on front and rear wheels (PV 444 A and B, PV 445 A and B).

SVO 1457 Wrench for master cylinder filler cap (PV 444 A and B, PV 445 A and B).

SVO 1791 Puller for hub with brake drums on front and rear wheels (from PV 444 C and PV 445 D onwards).

SVO 1794 Puller for inner bearing on forward steering knuckle (from PV 444 C and PV 445 D onwards).

SVO 2119 Staking tool for adjuster cam bolt.
SVO 2049 Flanging tool for steel piping (the brake line).

SVO 2197 Drift for fitting and removing of front wheel hub lubricating cap.

SVO 4016 Puller for inner bearing on steering knuckle (PV 444 A and B, PV 445 A and B).

SVO 4074 Spring clamp for wheel unit cylinders.

SPECIFICATIONS

Master cylinder:			
Inner diameter		1"	
Clearance between plunger and cylinder		max. 0,127 mm (.005")	
		min. 0,025 mm (.001")	
Wheel unit cylinders:			
Diameter, front		1"	
,, rear, PV 444		7/8"	
,, " PV 445		1"	
Clearance between plunger and cylinder		max. 0,127 mm (.005")	
		min. 0,025 mm (.001")	
Fuel lines (piping):			
		PV 444	PV 445
Diameter		3/16"	3/16"
Length (late production), left front		500 mm (19.7")	530 mm (20.9")
" " " right front		920 mm (36.2")	1000 mm (39.37")
" " " left rear		500 mm (19.7")	350 mm (13.8")
" " " right rear		925 mm (36.4")	1110 mm (43.7")
" " " master cylinder—rear axle		2160 mm (85.0")	2240 mm (88.2")
Brake drums:			
Diameter, front		228,6 mm (9")	
,, rear		228,6 mm (9")	
Radial throw, max.		0.15 mm (.006")	
Brake linings:			
Width		2"	
Thickness		3/16"	
Hole diameter for contact plug		19 mm (.75")	
Length, forward shoe		260 mm (10.24")	
Length, rear shoe		200 mm (7.9")	
Brake lining rivets:			
Number		72	
Size		9/64" × 5/16" (3,5 × 8 mm)	
Return spring for brake shoe, total length at a pull of 15,5—20,5 kg (34—45 lb.)		154 mm (6.1")	
Effective brake lining area, early prod. (riveted lining)		850 cm ² (133 sq.in.)	
Effective brake lining area, late prod. (bonded lining)		930 cm ² (145 sq.in.)	
Clearance between brake shoes and drum		0,10 mm (.004")	
Pedal free play		7—12 mm (1/4"—1/2")	