

CONTENTS 49

Description	1
Repair instructions	8
Battery	8
Dynamo	8
Charging relay	8
Starter motor	8
Ammeter	9
Fuel gauge	9
Headlights	9
Number plate lighting	11
Stop and rear lights	11
Traffic indicators	13
Horn	15
Windscreen wiper	16
Instrument and internal lights	16
Main lighting switch	16
Electric cables	17
Fuses	17
Fault tracing	17
Specifications	18
Circuits	

DESCRIPTION

PV 444—445 have a 6-volt electrical system. The system may be suitably divided into battery, dynamo, charging relay, starter motor, instruments, lighting and indicator devices as well as the necessary cables.

The battery is mounted on a shelf on the front of the mounting board. It is a lead battery con-

sisting of three cells and has a capacity of 85 amp. hours.

The dynamo is located on the right-hand side of the engine and is driven from the crankshaft by means of a V-belt. It is a shunt-type dynamo, i.e. the field windings are connected in parallel with the armature. Charging is regulated by means of the charging relay.

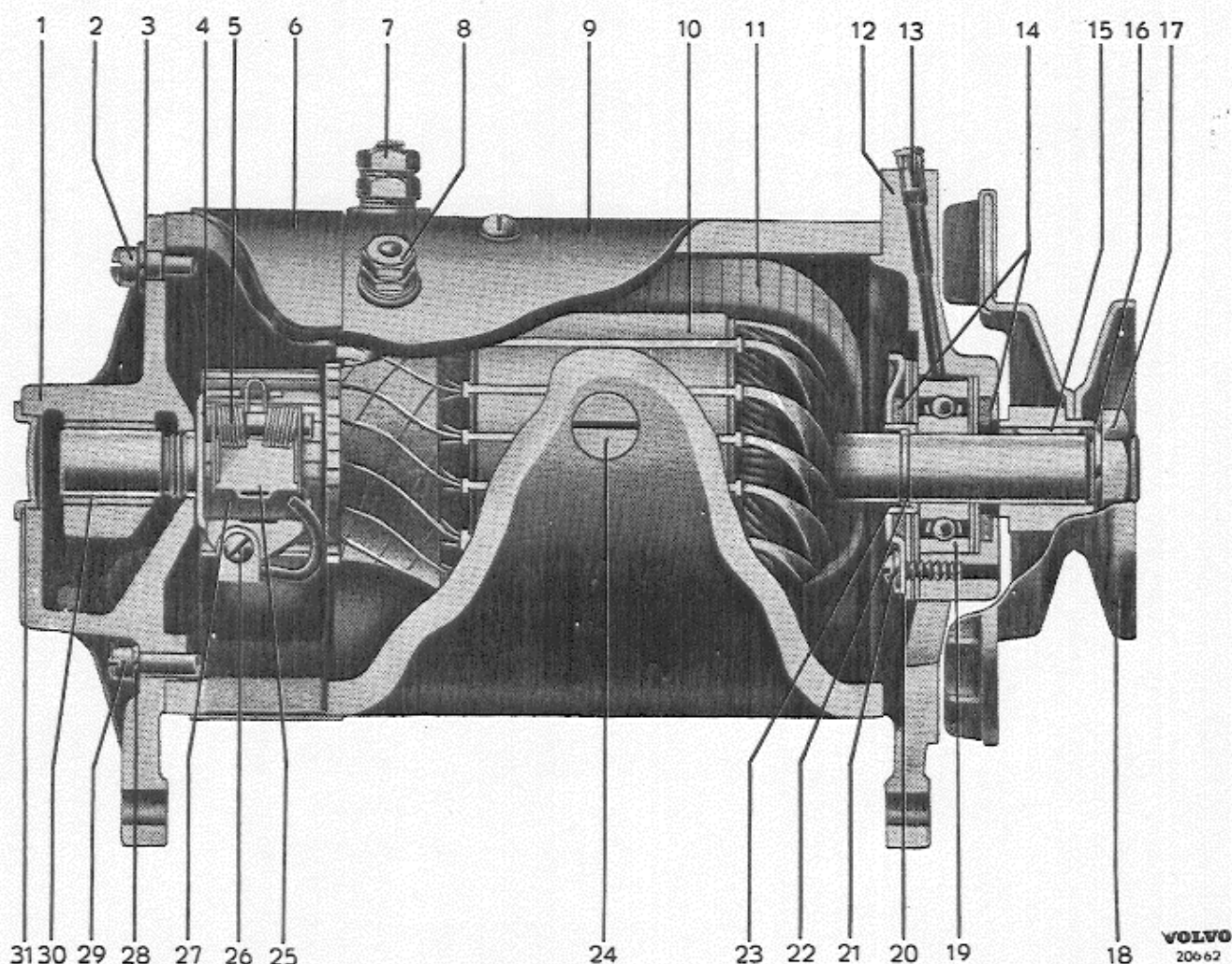

Fig. 1. Dynamo (Auto-Lite).

- | | | | |
|-----------------------|-------------------------|------------------------------|-------------------|
| 1. Rear head assembly | 9. Housing | 17. Nut | 25. Brush arm |
| 2. Screw | 10. Armature | 18. Drive pulley | 26. Screw |
| 3. Spring washer | 11. Field coil | 19. Ball bearing | 27. Brush |
| 4. Brush holder | 12. Front head assembly | 20. Cover | 28. Spring washer |
| 5. Spring | 13. Front lubricator | 21. Screw with spring washer | 29. Screw |
| 6. Cover band | 14. Seals | 22. Retainer ring | 30. Bushing |
| 7. Armature terminal | 15. Woodruff key | 23. Sleeve | 31. End cover |
| 8. Field terminal | 16. Spring washer | 24. Pole shoe screw | |

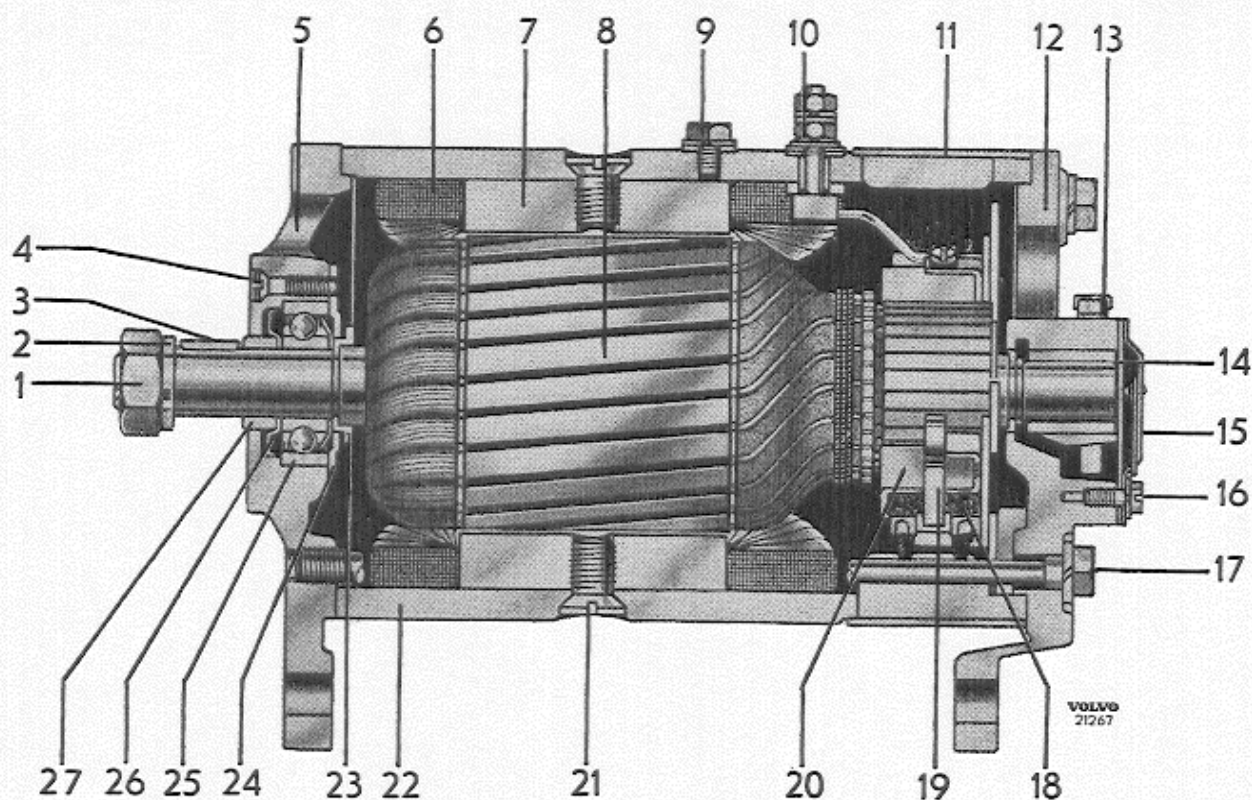

Fig. 2. Dynamo (Bosch, early production).

- | | |
|-------------------------|-----------------------------|
| 1. Nut | 15. End cover |
| 2. Spring washer | 16. End cover screw |
| 3. Woodruff key | 17. Screw |
| 4. Screw | 18. Brush |
| 5. Front head assembly | 19. Brush spring |
| 6. Field coil | 20. Brush holder |
| 7. Pole shoe | 21. Pole shoe screw |
| 8. Armature | 22. Dynamo housing |
| 9. Earthing cable screw | 23. Washer |
| 10. Armature terminal | 24. Protector washer, inner |
| 11. Cover band | 25. Ball bearing |
| 12. Rear head assembly | 26. Protector washer, outer |
| 13. Lubricator | 27. Spacer ring |
| 14. Bushing | |

The charging relay is fitted on the right-hand side of the front on the mounting board. It is connected to the dynamo and the battery by means of cables. The charging relay functions on the constant voltage control principle. Apart from the voltage regulator there is also a current regulator and a cut-out relay.

The starter motor consists of a four-pole series motor. There are two types. The earlier type is fitted with a Bendix drive, the starting

circuit being completed by means of a relay. The later type is fitted with a sliding pinion which is operated by a solenoid starter switch which also connects the starting current.

Dynamo, relay and starter motor circuits are shown in fig. 8.

For more information about dynamo, charging relay and starter motor see in the general section (PV 10).

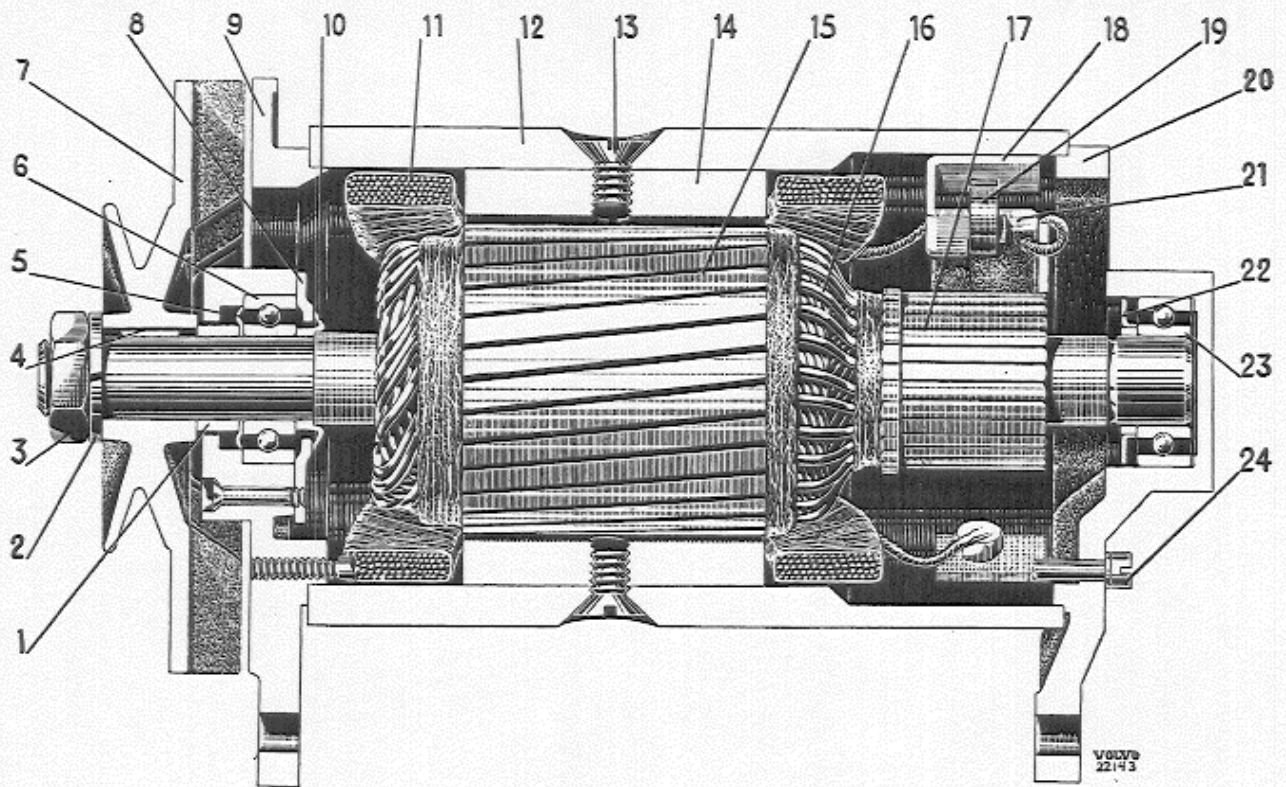
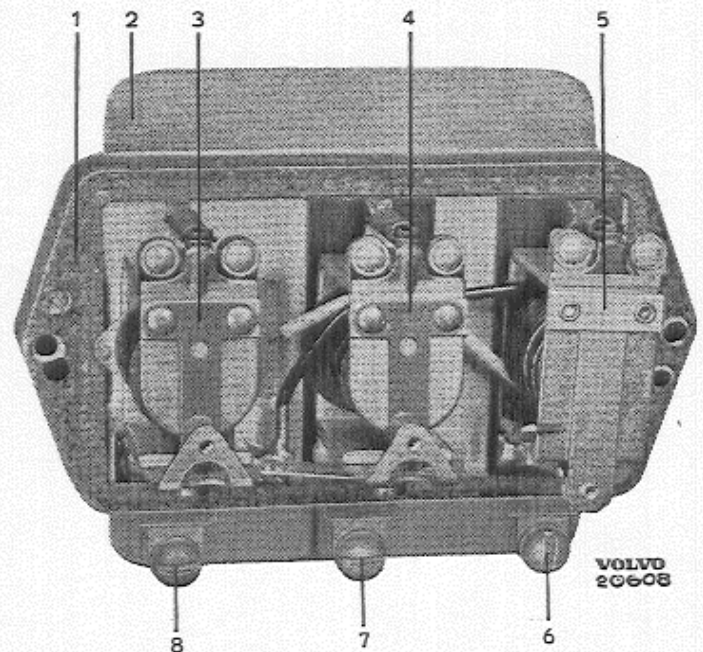

Fig. 3. *Dynamo (Bosch, Late prod.).*

- | | | | |
|---------------------|------------------------|----------------------|------------------------|
| 1. Distance sleeve | 7. Pulley | 13. Pole shoe screw | 19. Brush spring |
| 2. Spring washer | 8. Protector washer | 14. Pole shoe | 20. Rear head assembly |
| 3. Nut | 9. Front head assembly | 15. Armature | 21. Brush |
| 4. Woodruff key | 10. Spacing ring | 16. Armature winding | 22. Protector washer |
| 5. Protector washer | 11. Field winding | 17. Commutator | 23. Ball bearing |
| 6. Ball bearing | 12. Dynamo housing | 18. Brush holder | 24. Screw |

Fig. 4. *Charging relay (Auto-Lite).*

1. Cork gasket
2. Relay body
3. Voltage regulator
4. Current regulator
5. Cut-out relay
6. Battery terminal
7. Field terminal
8. Armature terminal



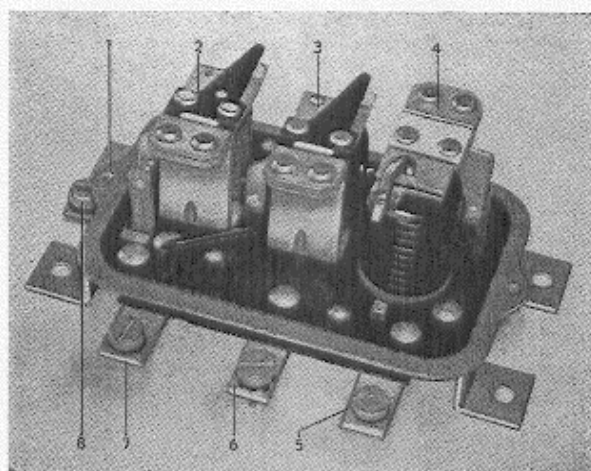

VOLVO
21269

Fig. 5. Charging relay (Bosch)

1. Relay body
2. Voltage regulator
3. Current regulator
4. Cut-out relay
5. Battery terminal
6. Field terminal
7. Armature terminal
8. Earth cable terminal

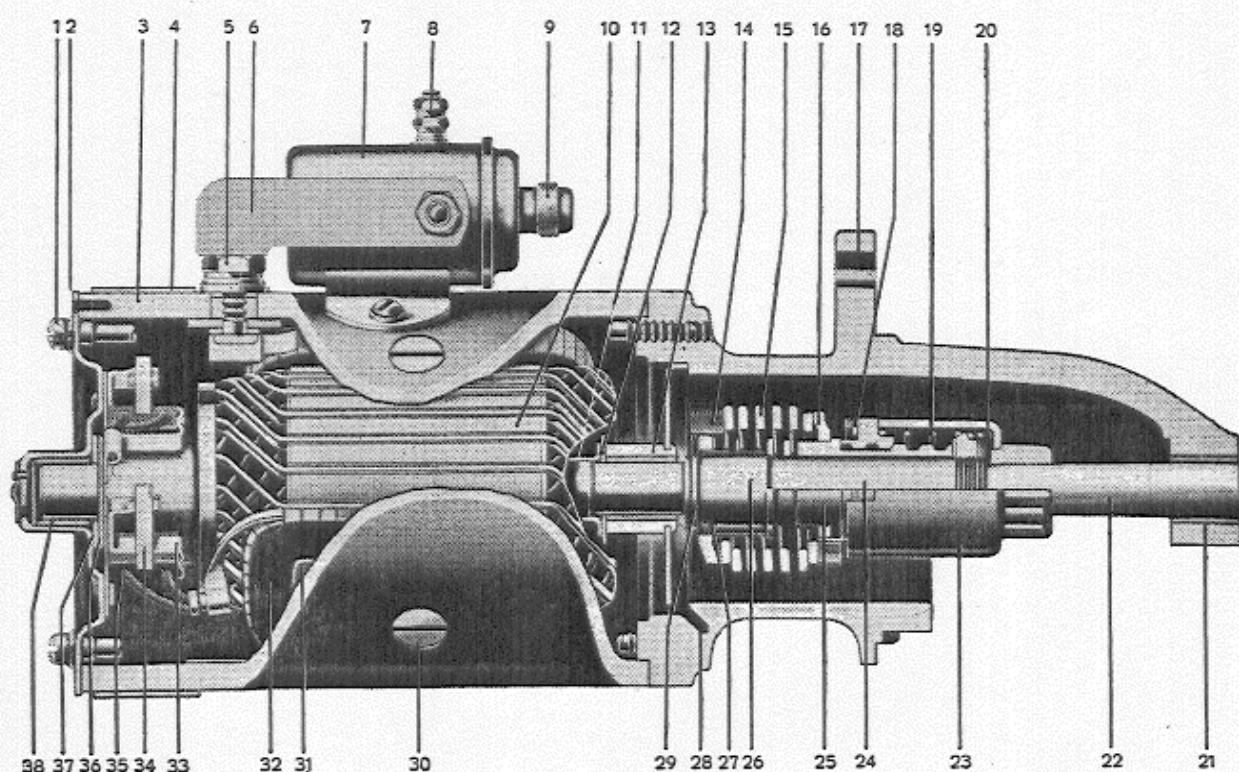

VOLVO
20618

Fig. 6. Starter motor (Auto-Lite with starter relay and Bendix gear).

- | | | | |
|-----------------------------|----------------------------|--------------------|-------------------|
| 1. Screw with spring washer | 11. Spacer | 21. Bushing | 31. Pole screw |
| 2. Rear head assembly | 12. Thrust washer | 22. Armature shaft | 32. Field coil |
| 3. Housing | 13. Bearing | 23. Pinion | 33. Brush holder |
| 4. Cover band | 14. Spring retainer, inner | 24. Shaft | 34. Spring |
| 5. Pole screw | 15. Bendix spring | 25. Sleeve | 35. Brush |
| 6. Connector | 16. Spring retainer, outer | 26. Drive ring | 36. Washer |
| 7. Starting relay | 17. Pinion housing | 27. Lock screw | 37. Thrust washer |
| 8. Pole screw | 18. Lock ring | 28. Guide pin | 38. Bushing |
| 9. Dust cover | 19. Return spring | 29. Lock ring | |
| 10. Armature | 20. Damping spring | 30. Screw | |

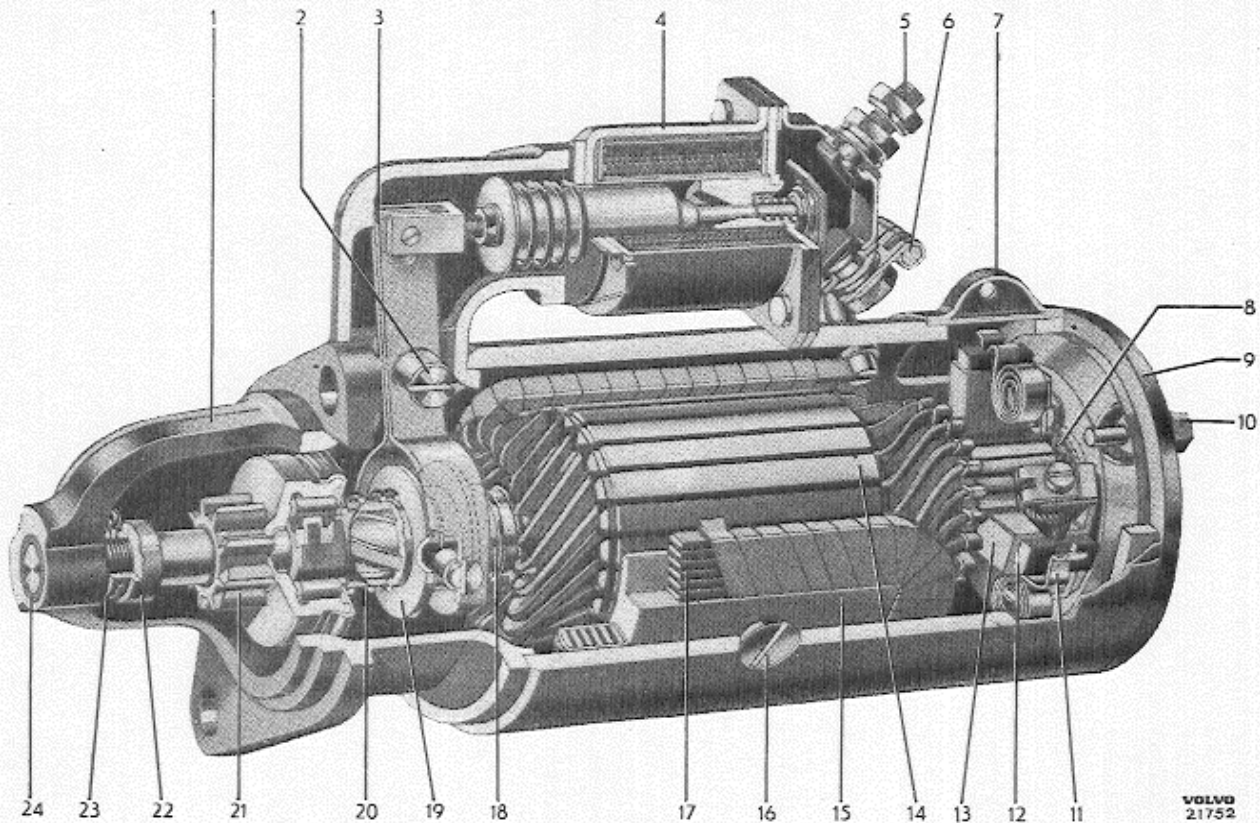

Fig. 7. Starter motor (Bosch with solenoid).

- | | | |
|---|------------------------|---------------------------|
| 1. Rear head assembly | 9. Front head assembly | 18. Spring for guide ring |
| 2. Screw for coupling arm | 10. Screw | 19. Guide ring |
| 3. Coupling arm | 11. Brush spring | 20. Spring for guide ring |
| 4. Solenoid | 12. Brush | 21. Pinion |
| 5. Terminal screw for battery lead | 13. Brush retainer | 22. Castle nut |
| 6. Connecting lead for field and armature | 14. Armature | 23. Split pin |
| 7. Protecting cover | 15. Pole shoe | 24. Bushing |
| 8. Armature brake | 16. Pole screw | |
| | 17. Field winding | |

The ammeter is fitted on the left-hand side of the instrument panel. It is connected between the charging relay and the battery. The ammeter shows the degree of charge or discharge of the battery at any given time.

The fuel gauge shows the level of the petrol in the fuel tank. It is fitted on the right-hand side of the instrument panel and is operated by a fuel gauge tank unit.

The headlights are mounted in the mudguards and are held in place by means of screws. The headlight units are fitted in holders with mounting rings. The mounting rings are held in place by means of four springs and two screws.

These screws also function as adjustment screws for headlight beam alignment.

The traffic indicators consist of two main types.

The earlier production consists of semaphore-type trafficators on each side of the car which light up yellow or red.

Later production traffic indicators are of the blinker type. There are three types, roof, side, and front and rear mounted. They are operated by an automatic blinking device which is fitted under the instrument panel. The control device is a short arm on the steering column below the steering wheel which operates the switch through a lever.

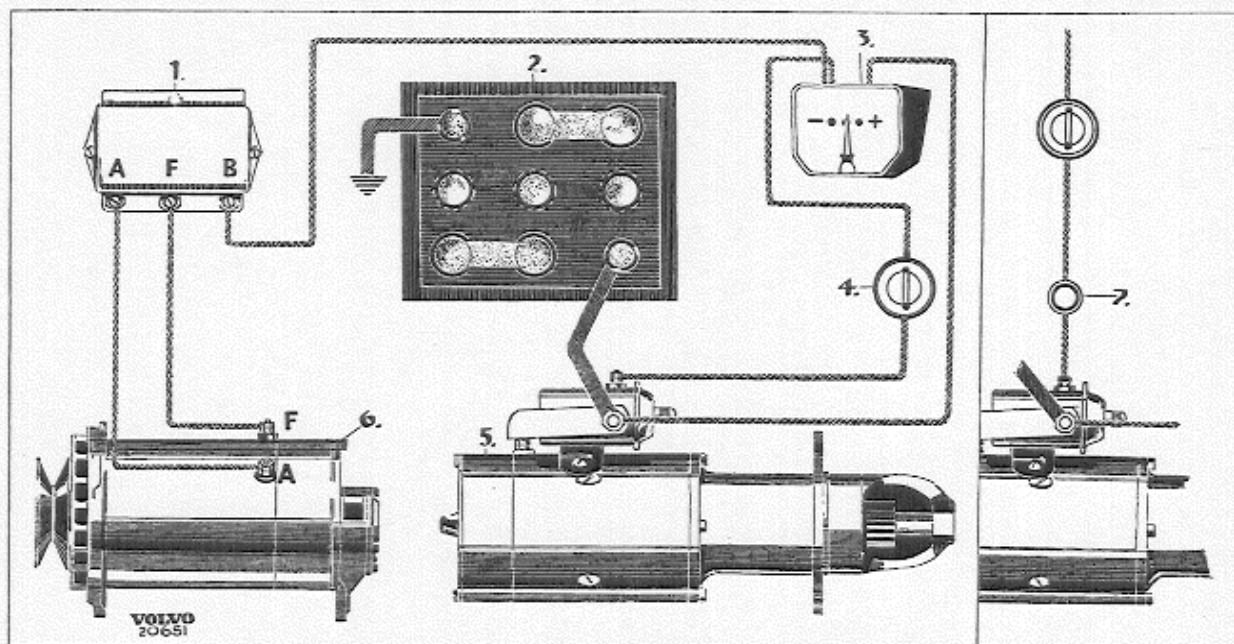

Fig. 8. Circuit diagram.

- | | | |
|-------------------|--------------------|--|
| 1. Charging relay | 4. Ignition switch | 7. Starter button on P 44403/4 Chassis |
| 2. Battery | 5. Starter motor | Nos. 1—12504 and P 445 Chassis Nos. |
| 3. Ammeter | 6. Dynamo | 1—500. |

Horns are of two types. P 44403 and P 445 are fitted with one horn while P 44404 is fitted with two, one high note and one low note. Cars with double horns are fitted with a relay for battery connection.

Fuses consist of wire filaments fitted on short porcelain bodies. The wires melt when the current exceeds the stipulated level. Fuses used are of 8 and 25 amps. They are contained in a fuse-box fitted on the mounting panel under the bonnet.

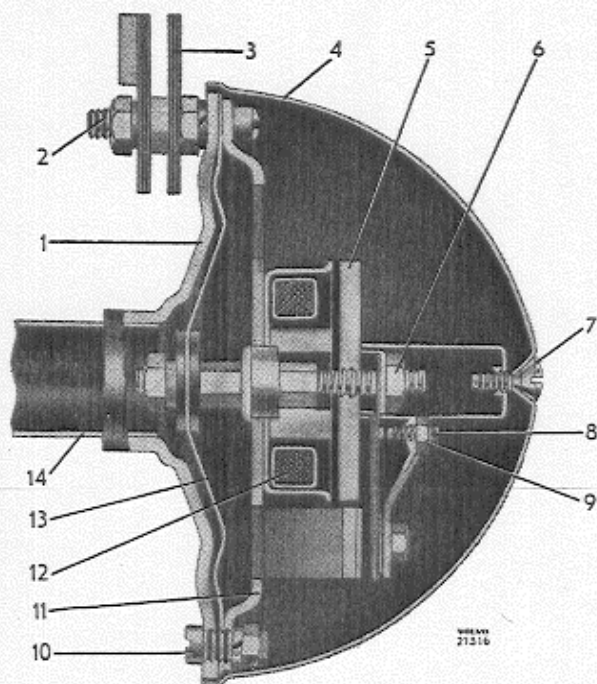
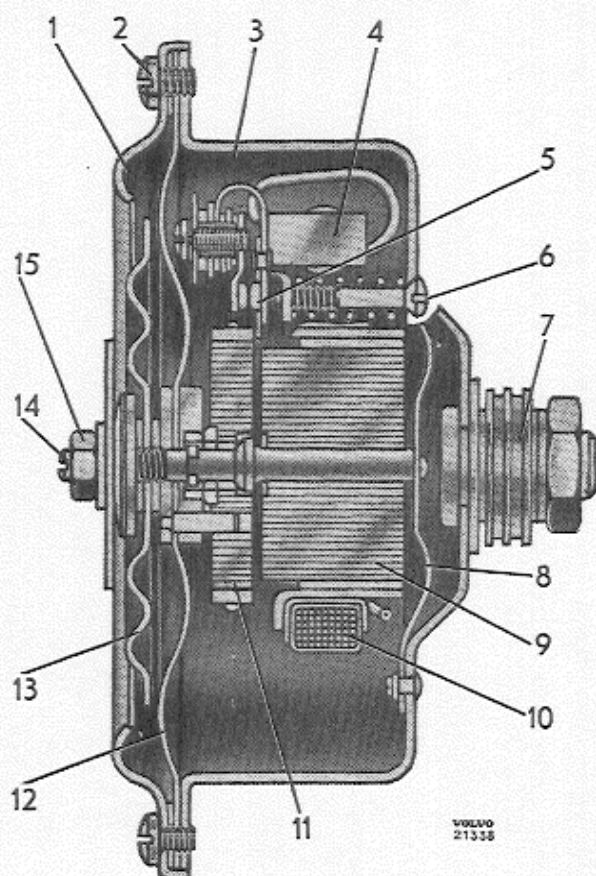

Fig. 9. Horn (Auto-Lite).

1. Cover
2. Screw
3. Attachment springs
4. Housing
5. Armature
6. Armature adjusting nut
7. Housing screw
8. Circuit breaker adjusting screw
9. Lock nut
10. Screw
11. Armature retainer
12. Winding
13. Diaphragm
14. Sound amplifier



1. Cover
2. Screw
3. Housing
4. Condenser
5. Contact breaker
6. Contact adjusting screw
7. Attachment
8. Leaf spring
9. Soft iron core
10. Winding
11. Armature plate
12. Diaphragm
13. Vibrating disc
14. Adjusting screw
15. Lock nut

Fig. 10. Horn (Bosch)

REPAIR INSTRUCTIONS

Battery

Maintenance

See under "Battery" in the general section (PV—10).

Removal

1. Remove cable clamps from battery terminals. Use a puller if the clamps are very tight.
2. Loosen the wing nuts on the retainer band and lift out the battery.
3. Brush off the battery with a brush and rinse clean with tepid water.
4. Clean the battery shelf and the cable clamps. Use a wire brush or special pliers on the cable clamps.

Installation

1. Place the battery in position. Ensure that it is turned the right way. Tighten in position by means of the retainer band and the wing nuts.
2. Tighten the cable clamps on the battery terminals. The negative terminal is earthed.
3. Smear terminals and cable clamps with vaseline.

Dynamo

Precautions before removing

See under "Dynamo" in the general section.

Removal

1. Remove cable clamp from battery negative terminal.
2. Disconnect cables from dynamo.
3. Loosen the V-belt tension device and lift off V-belt.
4. Remove the two bolts attaching dynamo to engine and remove.
5. Clean dynamo externally with a cloth soaked in petrol. For dynamo overhaul, see general section.

Installation

Installation is carried out in the reverse order to removal. The attachment bolts should be se-

cured by means of lock washers or lock nuts and cotter pins. Do not stretch the V-belt too tightly. It should be possible, when tension is correct, to press in the belt about 10 mm ($\frac{25}{64}$ "") at a point midway between the pulleys. (See fig. 11). Ensure that cables are connected correctly.

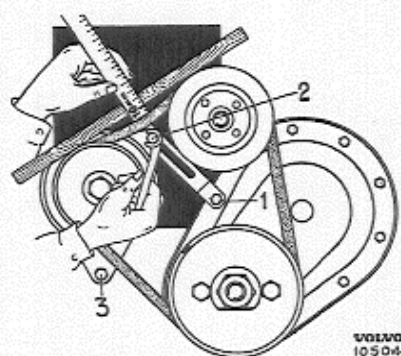

Fig. 11.

Charging relay

Adjustment in car

See under "Charging Relay" in general section.

Removal

1. Disconnect the three cables from the charging relay.
2. Remove relay from mounting board.
3. Clean thoroughly externally.

Installation

1. If the relay is to be replaced, make sure that the correct type is fitted.
2. Screw into position on the mounting board.
3. Connect the cables. The cable from the dynamo armature terminal is connected to the terminal marked A, Arm or D+, from the dynamo field terminal to the terminal marked Fld or DF, and from the battery to Bat or B.

Starter motor

Precautions before removal

See under "Starter motor" in the general section.

Removal

1. Remove cable clamp from battery negative terminal.
2. Disconnect the cables from the starter motor relay or solenoid switch.
3. Remove the screws which hold the starter motor in position on the flywheel housing and remove it.
4. Clean externally with a cloth soaked in petrol. For overhaul, see general section.

Installation

Installation is carried out in the reverse order to removal. Tighten nuts evenly but not too hard. Connect cables carefully.

Ammeter

Examination and testing

See "Ammeter" in general section.

Removal and installation

See "Replacement of ammeter" in Part 11.

Fuel gauge

Examination and testing

See "Fuel gauge" in general section.

Removal and installation

See "Replacement of fuel gauge" in Part 11.

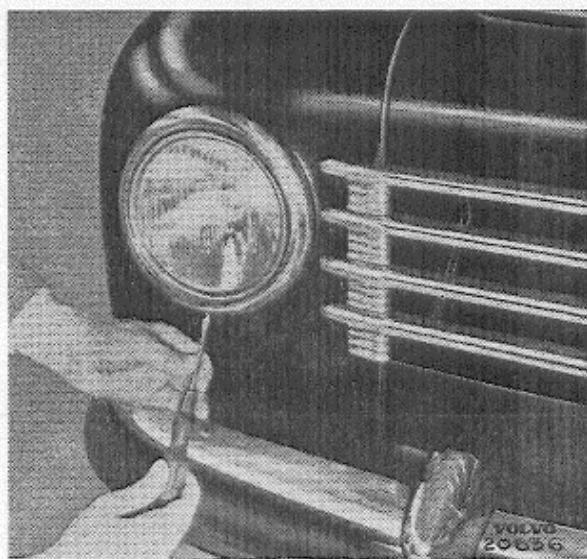

Fig. 12.

Headlights

Replacement of headlights

If a headlight is to be completely dismantled follow the instructions below. For partial dismantling follow the relevant instructions.

1. Remove the headlight rim screw (fig. 12). Remove rim by pulling out the lower part slightly and then lifting upwards.
2. Loosen the screws (1—3, fig. 13) on the headlight unit holder (4). Turn until the hooks are free from the screws and then lift out the holder, headlight unit and bulb-holder.

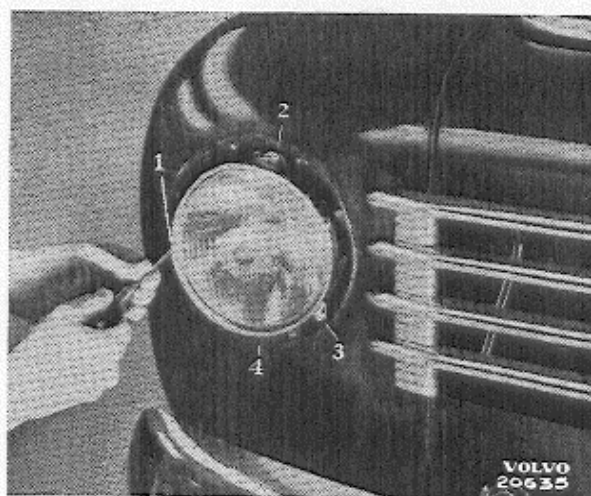

Fig. 13.

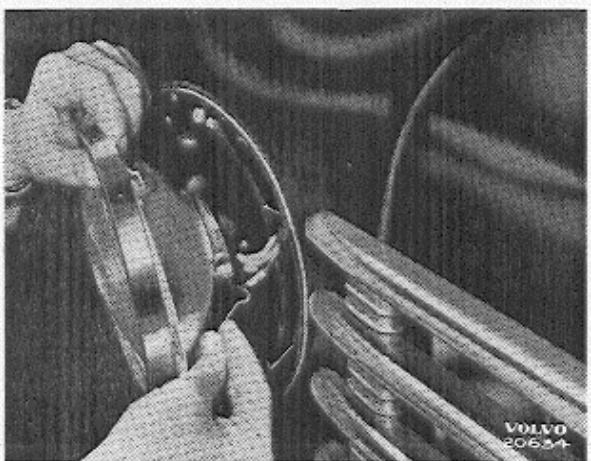

Fig. 14.

3. Remove the spring holding the bulb-holder to the headlight unit (fig. 14). Separate the unit from the holder and remove the bulbs.

4. Disconnect the leads from the bulb-holder and mark them to assist reconnection and avoid mistakes. If only the bulb-holder is to be replaced, it is then best to disconnect one lead at a time and reconnect directly to the new bulb-holder.

From chassis No. 131918 onwards the bulb-holder is provided with a socket. The leads have a plug which is released from the bulb-holder by pulling straight back. See fig. 15.

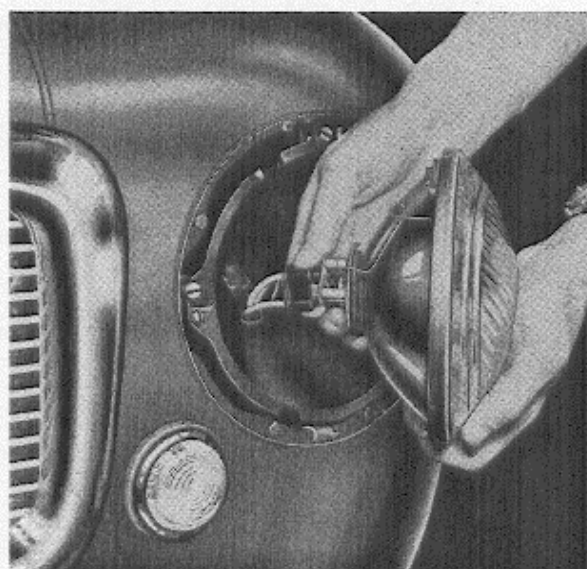

Fig. 15.

VOLVO
23305

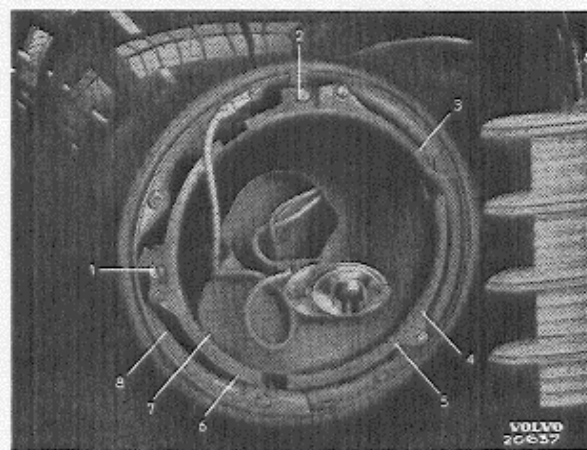

Fig. 16. Early production.

5. Loosen the adjustment screws (1 and 2 figs. 16 and 17) for headlight alignment, 8—10 turns. Unhook the springs (3—6) from the mounting bowl (7). Remove the bowl from the holder (8).
6. Remove the springs and adjustment screws from the holder.

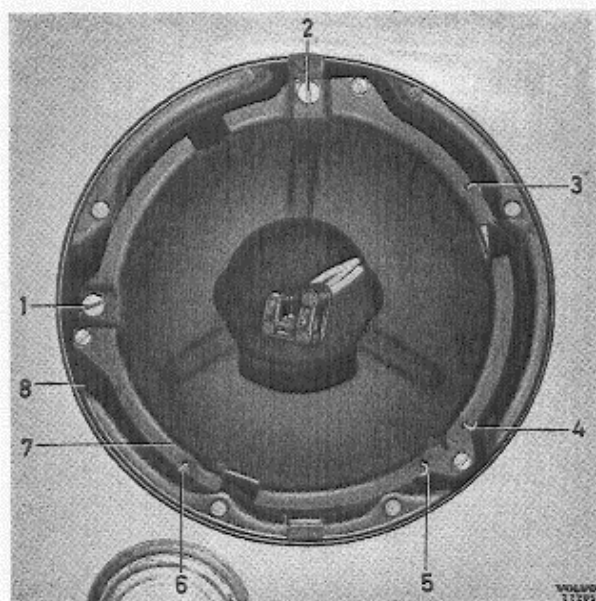

Fig. 17. Late production.

7. Loosen the holder from the mud-guard and pull out the lead and the rubber bushing. Remove rubber seals.
8. Install in reverse order. Make sure that the leads are correctly connected and that the screws are properly tightened. Do not forget to connect the earthing cable.

Replacement of bulbs

1. Proceed as shown in points 1—3 in "Replacement of headlights".



Fig. 18.

2. Remove the faulty bulb.
3. Insert the new bulb. This is done as shown in fig. 18. Do not touch the glass with the fingers but just pull the socket as far out of

the carton as is necessary to fit the bulb. Dirt, oil etc., on the glass burn on and can damage the reflector when they carbonize. Headlight efficiency is thereby reduced considerably.

4. Fit the remaining parts in the reverse order to that employed when removing.

Alignment of headlights

See general section.

Number plate lighting

Replacement of bulb in number plate lighting

1. Remove the rubber sleeve and then push the unit with bulb forwards by using a screwdriver as shown in fig. 19.
2. Remove the faulty bulb by pressing it inwards and anti-clockwise at the same time.
3. Fit the new bulb. Do not touch the glass with the fingers, fig. 20.
4. Replace the unit into the holder and press on the rubber sleeve.

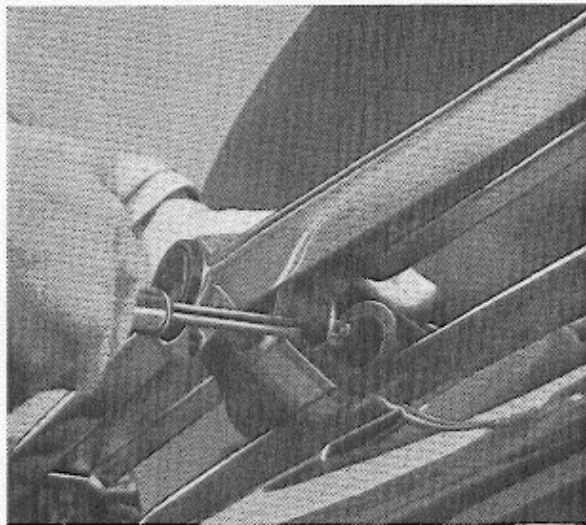

Fig. 19.

Stop and rear lights

Replacement of stop and rear lights

P 44403/4, Chassis Nos. 1—68955

1. Loosen the screw which holds the housing on the bulb-holder. Pull housing backwards and remove.

2. Remove the faulty bulb and fit the new as shown in fig. 21. There are two types of bulb-holder. The late production bulb-holder only allows the fitting of the bulb in one position.

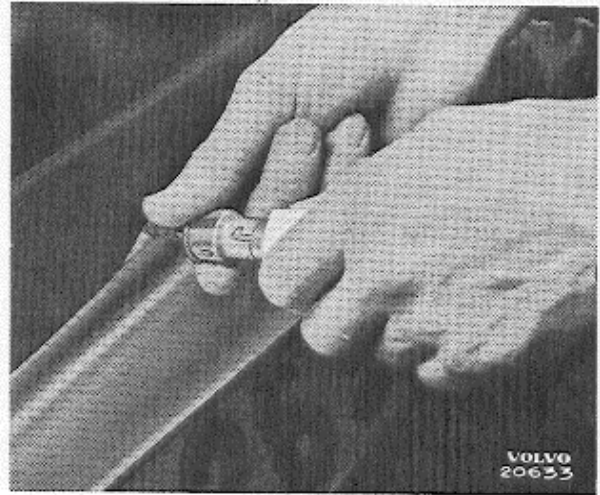

Fig. 20.

3. If the bulb-holder is to be replaced, the nuts on the inside of the mud-guard are removed after the cables have been marked and disconnected from the bulb-holder.
4. Ensure that the rubber washer lies correctly so that a good seal is ensured.

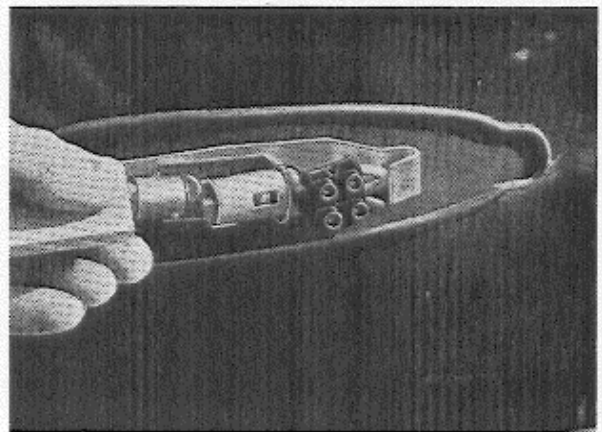

Fig. 21.

P 44403/4, Chassis Nos. 68956—131917

1. The bulb is accessible for replacement from the luggage compartment. The bulb-holder is removed by prising it to one side, see fig. 22.

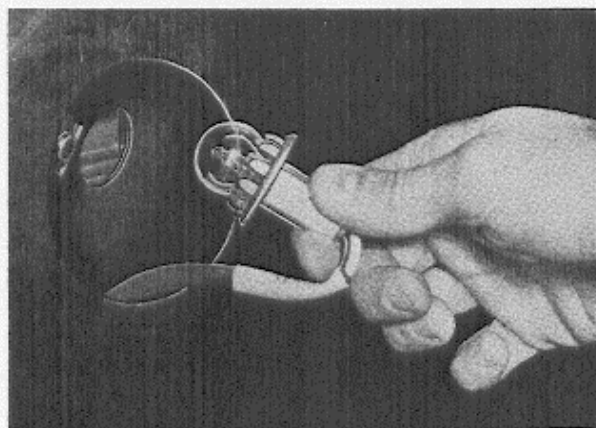

Fig. 22.

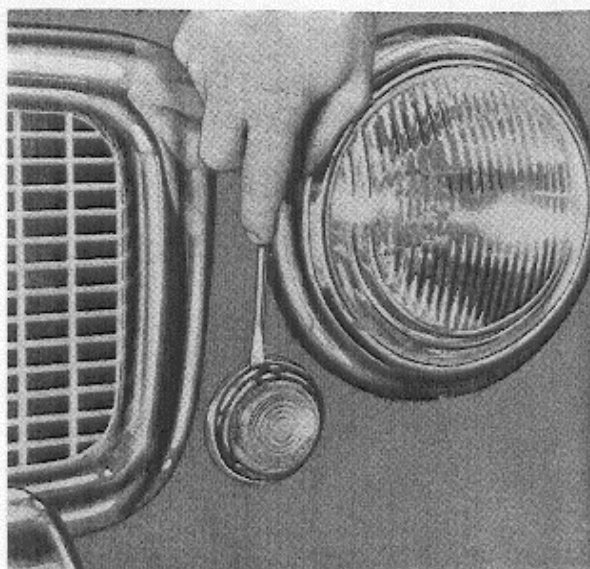

Fig. 24.

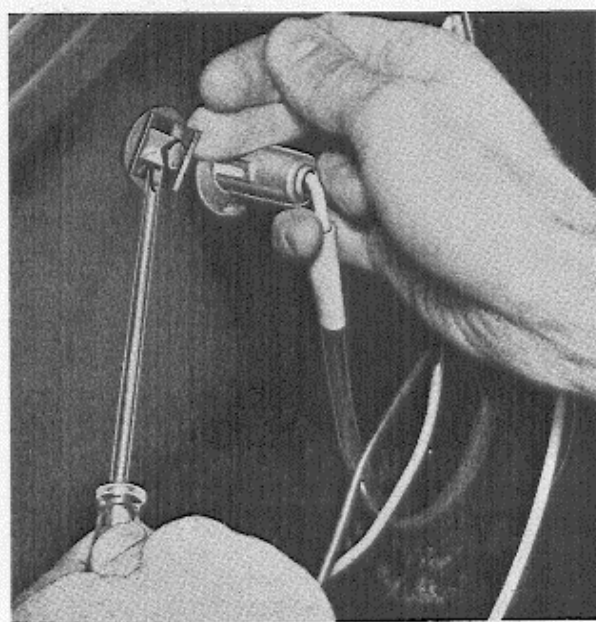

Fig. 23.

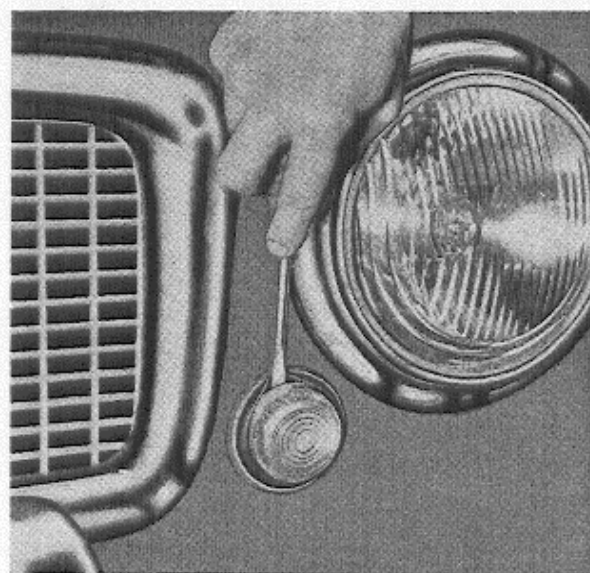

Fig. 25.

2. The new bulb is then inserted. Notice that the contacts in the bulb socket are, of different heights so as to obviate the possibility of fitting incorrectly. Do not hold the bulb glass with bare fingers, but use the packing carton. See fig. 21.
3. If the lamp housing has to be changed, this is done by removing the three locking washers with a screwdriver. See fig. 23. The best way of carrying this out is to first fold back the fibre sides.

P 44403/4, Chassis Nos. 131918 onwards

At the front the parking lamps and blinkers are combined and at the rear the stop light,

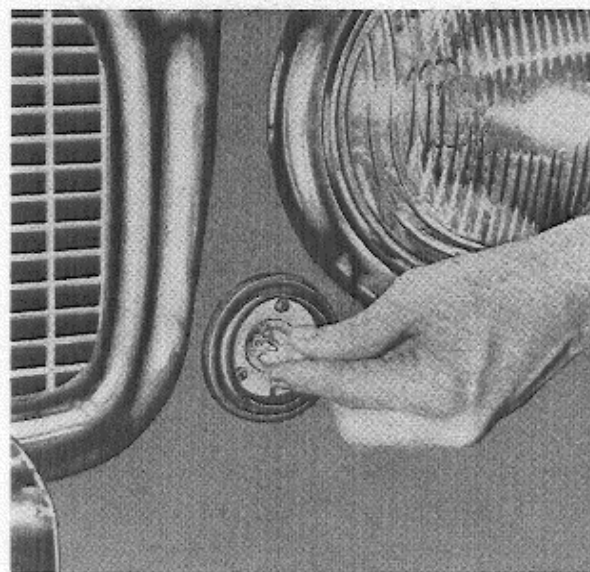

Fig. 26.

rear light and blinkers are combined. Changing the bulbs at the front is done as follows:

1. Loosen the rim with a screwdriver, see fig. 24.
2. Release the glass in the same way, see fig. 25.

As the rear lights are of the same pattern as the front lights, these are also replaced in a similar manner.

Traffic indicators

Trafficator type (semaphore)

This type of traffic indicator is fitted on P 44403/4 Chassis Nos 1—12504. It is recessed into the body to the rear of the door and is held in position by means of screws. The operating switch is located on the instrument panel.

When fitting this type of traffic indicator make sure that the upper part of the indicator arm is not bent in any way. One result of this can be that the electro-magnet or hinge mechanism may jam.

Cleaning and lubrication

The traffic indicator is unscrewed from the body, cleaned in petrol and blown dry with compressed air.

Lubricate sparingly. Oil the electro-magnet very slightly. The roller, shaft, sliding surfaces and spiral spring bearing on the lever catch should be smeared with grease and coated with oil. The inside ends of the bearings should be

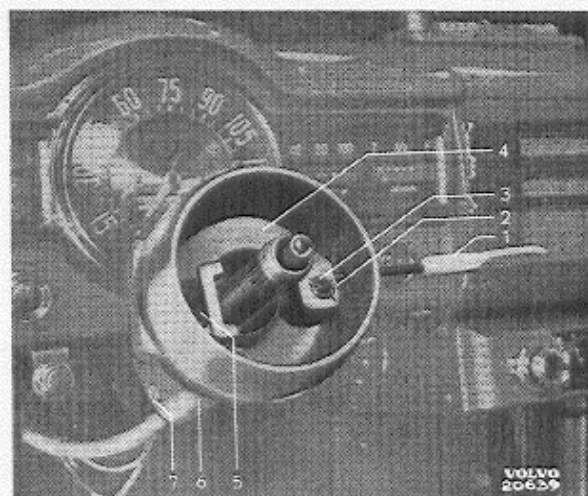

Fig. 27.

lubricated with a few drops of oil. The catch and return spring, as well as the contact and spring for the bulb, should be smeared with grease.

SAE 10 oil should be used for lubrication and heat and cold-resistant grease which contains vaseline.

Traffic indicators, blinker type

Removal of housing with switch

1. Remove the steering wheel as described in Part 6.
2. Screw out the operating arm (1, fig. 27) from the lever (4). Remove the cotter pin (2) and washer (3) and lift the lever and rubber stop (5) out of the housing (6).
3. Remove the two screws which hold the switch (1, fig. 28) in the housing.
4. Disconnect the cables (1 and 2, fig. 29) from the blinkers and the cables (3—6) at the

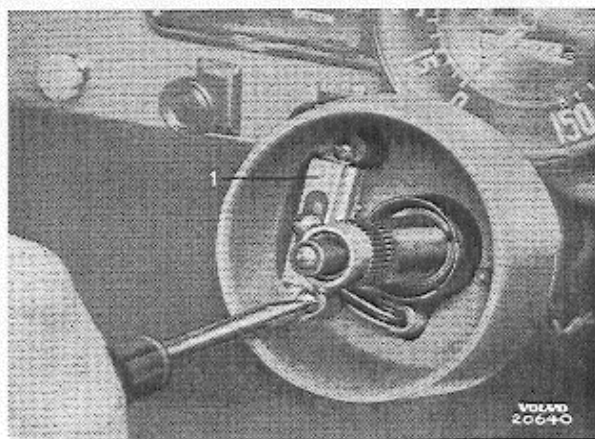

Fig. 28.

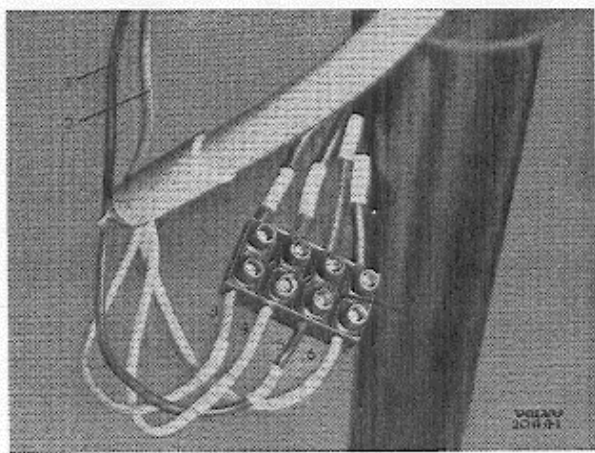

Fig. 29.

connector (7). Mark all cables to ensure correct reconnection.

- Loosen the retainer screw (7, fig. 27) right out and slide the housing off the steering column. Remove switch and cable.

On P 44403/4 chassis Nos. 26905 onwards and P 445 chassis no. 1991 onwards there is a new type of traffic indicator switch fitted. See figs. 30 and 31.

The operating arm, which is on the left-hand side of the steering wheel, is connected to the switch by means of a hub and a shaft.

The switch is attached to the housing by means of four screws (7).

Removal of the housing and switch is carried out as shown. To remove the switch from the housing, the hub must be removed. This is done by loosening the nut which holds the hub on the shaft.

The cables are coupled to a 6-point connector under the instrument panel. Fig. 32 shows the plug disconnected.

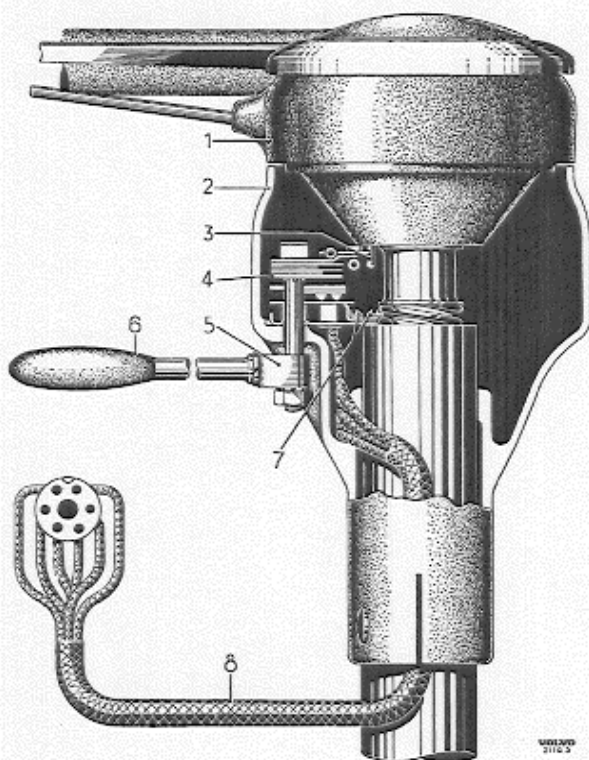

Fig. 30.

- | | |
|-----------------------------|----------------------------------|
| 1. Steering wheel | 5. Hub |
| 2. Housing | 6. Lever |
| 3. Pin | 7. Screw for switch |
| 4. Traffic indicator switch | 8. Cables with 6-point connector |

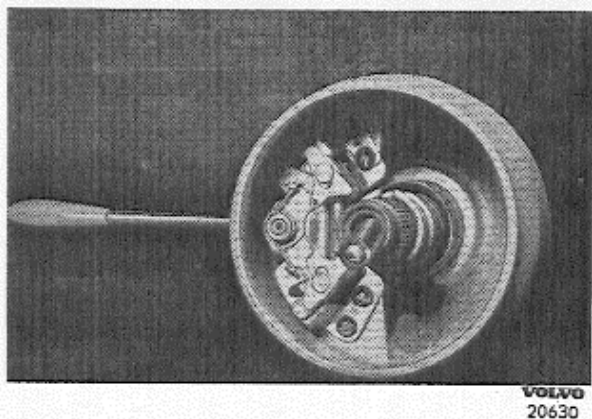

Fig. 31.

Installation

- Thread cable with switch through housing and screw switch into position.



Fig. 32.

- Stretch the lead and press it into the groove in the housing. Screw in the retainer screw.
- Slide the housing down the steering column and tighten the screw so that the housing is firmly in position. Make sure that it is sufficiently far down the column so that it does not come into contact with the steering wheel hub when this is fitted.
- Couple the cables to the blinkers and the connector and ensure, with the help of the markings, that the leads are connected correctly.
- Oil the lever bearing pin and press it into position. Fit the rubber stop on the lever.

6. Screw the arm into the lever. Switch on the ignition and make sure that the blinkers operate properly. Move the lever back into the neutral position and switch off the ignition.
7. Fit the washer and cotter pin to the end of the shaft.
8. Fit the steering wheel as shown in Part 6. Make sure that the switch is in the neutral position before the steering wheel is fitted. Do not forget to adjust the housing after the steering wheel nut is tightened.



Fig. 33. Traffic indicator (Roof mounted type).



Fig. 34. Traffic indicator for P 44403/4 Chassis Nos. 28005—37004 (late prod.) and chassis Nos. 37005—68955.

When fitting the housing and switch of later production follow the relevant points above. Adjustment of the housing by means of a jig (see Part 6) is not necessary. After the steering wheel is fitted adjust the housing so that there is a clearance of 1—1.5 mm ($1/32$ "— $1/16$ "") between the upper part of the housing and the steering wheel hub.

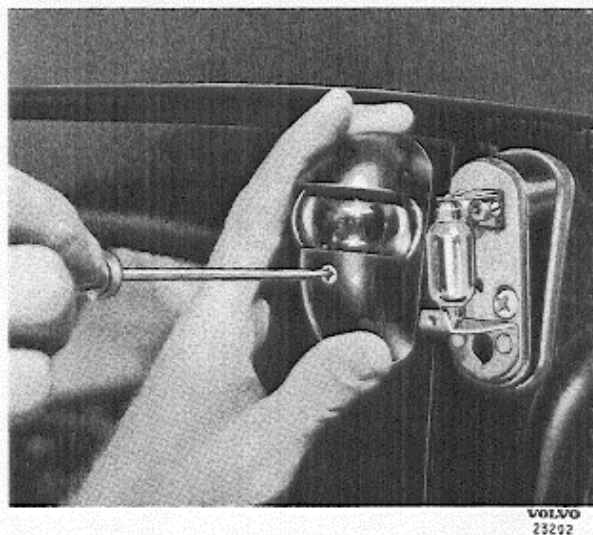

Fig. 35. Traffic indicator for P 44403/4 Chassis Nos. 68956—131917.

Replacement of bulbs

Loosen the two screws on the upper part and lift off the cover. The outer bulbs are then accessible for replacement. The central bulb is attached to a bracket which is held in place by means of two screws. This bracket must be loosened as shown in fig. 33. Do not touch the glass with the fingers as it reduces the efficiency of the bulb if it is smeared with grease or oil.

The covers of the side-mounted blinker type traffic indicators are attached by means of screws, see figs. 34 and 35.

Concerning front and rear mounted traffic indicators see under "Stop and rear lights".

Horn

Examination and adjustment

See "Horn" in general section.

Removal and installation

On vehicles with the horn mounted on the intermediate member, the horn is released by removing the radiator grille after which the

leads can be removed and thereafter the horn. On vehicles (special models) with double-tone horn, this is, on earlier production types, fitted on the mounting board whereas on later production types it is fitted on the intermediate member behind the radiator grille.

Fitting should be done carefully so that good earthing is obtained unless there is no special earthing lead.

The tone of the horn depends to a large extent on the rubber suspension and leaf spring which should therefore be checked. On models fitted with double-tone horns current is supplied through a relay. This is mounted on the left-hand side tubular member and on later production models on the left-hand side wheel housing plate.

Electrical windscreen wipers

Electrical windscreen wipers have been introduced on P 44403/4 chassis nos. 131918 onwards. See figs. 36 and 37. Regarding assembly and dismantling see part 11.

Lubrication and maintenance

The bushings on the wiper linkage arms are made of nylon. These bushings should be lubricated with thin oil (SAE 5W). The wiper arm

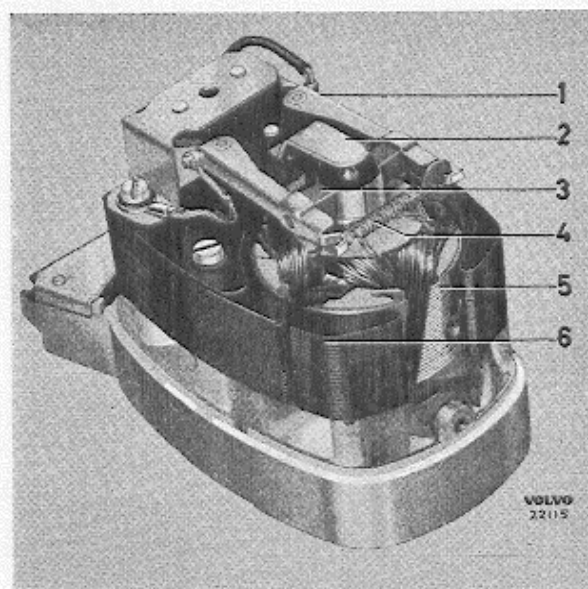

Fig. 36.

- | | |
|------------------------------|-----------------|
| 1. Brush retainer arm | 4. Brush spring |
| 2. Stop for rotor axial play | 5. Rotor |
| 3. Brush | 6. Pole shoe |

drive housing and the driving spindle should be smeared with grease at the same time. The wiper arm spindles should be oiled with thin motor oil after every 5000 km. (3100 miles).

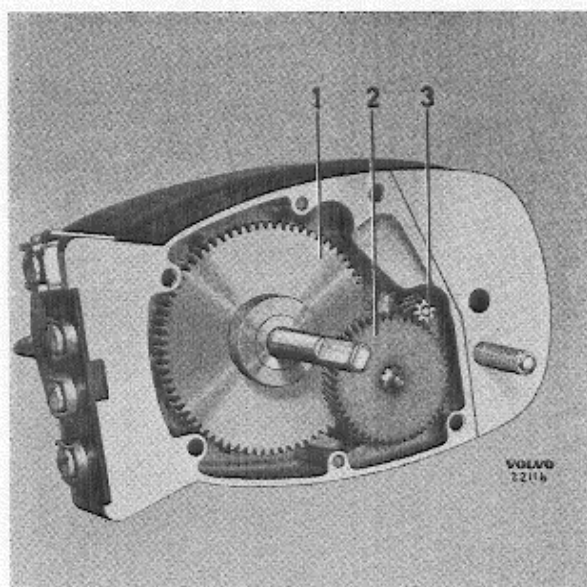

Fig. 37.

1. Drive spindle gear
2. Fibre countershaft gear
3. Rotor spindle drive pinion

Instrument and interior lights

The instrument lighting consists of 3 (late production 2) bulbs in sockets attached to the instrument mounting plates. On late production models there are 2 control lamps for the traffic indicators and 1 for the headlights. All bulbs are accessible for replacement from the rear of the instrument panel.

Interior lighting consists of a light either in the roof or on the door pillar. The bulb is accessible after the glass cover has been removed. On vehicles equipped with ignition switch lighting (door contact), this is accessible from the rear of the instrument panel.

Main lighting switches

The main headlight switch has three positions: off, parking lights and headlights.

The foot dipper switch has two positions: full and dipped. This switch is attached by means of screws to the underneath of the lower part of the mounting board.

Both the main switch and the dipper switch must be in good condition if the best lighting power is to be obtained. Damaged or faulty switches must, therefore, be replaced. If headlight power is bad then the switches must be examined and the voltage drop through them measured. This voltage drop should not exceed 0.1 volt.

The instrument lighting switch is situated low down on the left hand side of the instrument panel. The button operates an adjustable resistance so that the power of the lights may be regulated. This switch should be replaced if it becomes damaged.

As far as measurements of the electrical system are concerned, see general section.

Electric cables

The electric cables connecting the battery and the dynamo with the various instruments and electrical devices are shown in the various circuit diagrams. These diagrams also show marking and cross-section of the cables.

In order to avoid the menace to traffic safety as represented by "one-eyed" cars, the electrical system in later models has been adapted so that the parking lights operate even when the headlights are on. If a headlight bulb should burn out, the parking light on that side still functions.

If a cable has broken or is earthed, it must be replaced. Ensure that the new cable used has the same cross-section as the original. If a smaller cross-section lead is used this can cause overloading which means that heat is generated with subsequent damage to the leads and possibly also to the vehicle.

Fuses

Fuses on P 44403/4 and P 445 consist of 8 amp. and 25 amp. melt-type fuses. They are contained in a fuse box on the mounting board. There is a card under the fuses showing the various circuits covered by the fuse in question.

For further information about fuses, see general section.

FAULT TRACING

For tracing of faults in the electrical system see "Fault tracing" in the general section (PV—10).

SPECIFICATIONS

Battery

Voltage	6 volts
Earth connection	Negative terminal
Battery capacity, standard	85 amp. hours
Specific gravity of electrolyte, fully charged battery	1.275—1.285
" " " " when re-charging necessary	1.230

Recommended charging rate for various batteries:

Make	Type	Charging current
Boliden	3F06	6.0 amps.
SAAJ	GH 13-6	5.0 "
Tudor	3 DF 6	7.5 "

Ignition system

Firing order	1—3—4—2
Ignition setting, engine part no. 495300, 495301, 83 oct ROT	5° B.T.D.C.
" " engine part no. 495302, 83 oct ROT	5° A.T.D.C.
" " " " " " 93 oct ROT	2° B.T.D.C.
" " engine B16A part no. 495383, 83 oct ROT	2° A.T.D.C.
" " " " " " 93 oct ROT	4° B.T.D.C.
Ignition coil, production I	Auto-Lite IG-4090
" " " II	Auto-Lite CR-6001
" " " III	Bosch ZS/KZ/1/6
Sparking plugs, early prod.	10 mm thread
	Bosch U 175 T 3
	AC 104
	Auto-Lite P-6
	Champion Y 6 or equivalent
" " late prod.	14 mm thread
	Bosch W175T4
	AC 44 Com
	Auto-Lite A7
	Champion J7 or equivalent
Sparking plug gap	0.7- 0.8 mm
	(.028—.032")

Distributor

Type, B4B prod. I	Auto-Lite IGS-4210
" " " II	Auto-Lite IAT-4006
" " " III	Bosch VJU 4 BR9
" B16A	Bosch VJU 4 BR 20

Test values for Auto-Lite distributor

Direction of rotation: clockwise

Ignition advance curves

Centrifugal regulator:

Degrees advance on distributor	0	4	7.5	13	17.5
Distributor speed r.p.m.	250	355	450	1160	1750

Vacuum regulator:

Degrees advance on distributor	0	1	3	6	7.5
Vacuum, cm Hg	10	14	22	35	40
" inches Hg	3.9	5.5	8.65	13.78	15.75

Contact breaker gap	0.45—0.55 mm (.0177—.0216")
„ breaker point pressure	0.48—0.57 kg (1.06—1.25 lb)
„ cam angle	47°
Condenser capacity	0.20—0.25 μ F (microfarads)

Test values for Bosch distributor

VJU 4 BR9

Direction of rotation: clockwise

Ignition advance curves

Centrifugal regulator:

Degrees advance on distributor	0	5	10	15	17.5
Distributor speed r.p.m.	140—300	280—450	560—920	1180—1580	1500—1900

Vacuum regulator:

Degrees advance on distributor	0	7.5±1
Vacuum, cm Hg	9—14	44
„ inches Hg	3.54—5.51	17.32

Contact breaker gap	0.4—0.5 mm (.016—.020")
„ breaker point pressure	0.4—0.5 kg (.882—1.10 lb)
„ cam angle	54±2°

VJU 4 BR20

Direction of rotation: clockwise

Ignition advance curves

Centrifugal regulator:

Degrees advance on distributor	0	5	10	14±1
Distributor speed r.p.m.	210—380	370—500	825—1200	1575—1925

Vacuum regulator:

Degrees advance on distributor	0	8±1
Vacuum, cm Hg	7—14	50
„ inches Hg	2.76—5.51	19.68

Contact breaker gap	0.4—0.5 mm (.016—.020")
„ breaker point pressure	0.4—0.5 kg (.882—1.10 lb)
„ cam angle	50±3°

Dynamo

Voltage	6 volts
Earth connection	Negative terminal
Direction of rotation	Clockwise

Type

Up to engine no. 12096	Auto-Lite GDZ-4821A
Engine no. 12097—43099	Auto-Lite GDZ-6001C
Output, continuous	Max. 35 amp.
Brushes, designation, 1 set = 2 brushes	Auto-Lite GGU-2012 S
„ designation, 1 brush	Auto-Lite GGU-1012

Test values

Brush spring tension	1.0—1.5 kg (2.20—3.3 lb)
Field coil	1.3—1.5 amp. at 5 volts
Dynamo as motor	3.9—4.4 amp. at 5 volts
Charging, cold dynamo:	
„ 6.4 volts 0 amps.	870—970 r.p.m.
„ 8 volts 35 amps.	1800—2000 r.p.m.

Charging, warm dynamo:	
" 6.4 volts 0 amps.	950—1050 r.p.m.
" 8 volts 35 amps.	2150—2350 r.p.m.

Type

Up to engine no. 43100	Bosch LJ/GJM 160/6—1500R10
Up to engine nos. 73049—74629 and with effect from 75220 onwards	Bosch LJ/GJM 160/6—1800R10
Output, continuous	Max. 40 amp.
Brushes, designation, positive brush, 1	WSK 35 L 1
" " negative brush, 1	WSK 35 L 3

Test values

Brush spring tension	0.45—0.60 kg (.992—1.32 lb)
Field coil	3.8—4.2 amp. at 5 volts
Dynamo as motor	6.8—7.2 amp. at 5 volts
Charging, cold dynamo (+20° C, 68° F) (LJ/GJM160/6—1500R10)	
" 6.4 volts 0 amp.	800—900 r.p.m.
" 8 volts 40 amp.	1750—1850 r.p.m.
Charging, warm dynamo (+60° C, 140° F) (LJ/GJM160/6—1500R10)	
" 6.4 volts 0 amp.	800—950 r.p.m.
" 8 volts 40 amp.	1900—2000 r.p.m.
Charging, cold dynamo (+20° C, 68° F) (LJ/GJM160/6—1800R10)	
" 6.4 volts 0 amp.	950—1050 r.p.m.
" 8 volts 40 amp.	1900—2000 r.p.m.
Charging, warm dynamo (+60° C, 140° F) (LJ/GJM160/6—1800R10)	
" 6.4 volts 0 amp.	1000—1100 r.p.m.
" 8 volts 40 amp.	2000—2200 r.p.m.

Type

Up to engine B 16 A	Bosch LJ/GG200/6-2300 R6...7
Output, continuous	Max. 49 amp.
Ratio, motor: dynamo	1: 1.8
Brushes, designation, 2	WSK 40L2

Test values

Brush spring tension	0.45—0.60 kg (.992—1.32 lb)
Field coil	4 amp. at 5 volts
Dynamo as motor	8 amp. at 5 volts
Charging, cold dynamo:	
" 6.4 volts 0 amp.	1850—1900 r.p.m.
" 8 volts 40 amp.	2575—2675 r.p.m.
Charging, warm dynamo:	
" 6.4 volts 0 amp.	1875—1950 r.p.m.
" 8 volts 40 amp.	2750—2850 r.p.m.

Charging relay

Voltage	6 volts
Negative terminal	Earthed

Type

(for dynamo Auto-Lite GDZ-4821 A)	Auto-Lite VRP-4007 C2
(for dynamo Auto-Lite GDZ-6001 C)	Auto-Lite VRP-6003 A
Series resistance	7 ohms (1) and 38 ohms (1)

Test values

Cut-out relay:	
Air gap between magnet and armature	0.031"—0.034" (0.79—0.86 mm)
Contact gap	Min. 0.015" (0.38 mm)
Adjusted for cutting in	6.5 volts
Adjusted for cutting out (reverse current)	4.1—4.8 volts (open circuit) 4—6 amp. (closed circuit)
Voltage control:	
Air gap between magnet and armature	0.048"—0.052" (1.22—1.32 mm)
Control voltage is adjusted to	7.35 volts
Current control:	
Air gap between magnet and armature	0.048"—0.052" (1.22—1.32 mm)
Control current is adjusted to	35 amp.
Test values apply in a temperature of	20°±1° C (68±2° F)

Type

(for dynamo Bosch LJ/GJM 160/6 1500R10 and 1800R10)	Bosch RS/UA 160/6/30 or 160/6/16
Balancing resistance AR	5.5—6.0 ohms
Control resistance W1	4.0—5.0 ohms

Test values

Cut-out relay:	
Air gap between magnet and armature	0.8—1.25 mm (.032"—.050")
Contact gap	0.4—0.8 mm (.016"—.032")
Adjusted for cutting in at	5.8—6.3 volts
Adjusted for cutting out at, reverse current	4—9 amp. (closed circuit)
Voltage control:	
Air gap between magnet and armature	0.8—1.2 mm (.032"—.047")
Contact gap (lower)	0.26—0.4 mm (.001"—.016")
Control voltage adjusted to (idling and half field current)	7.1—7.4 volts
Current control:	
Air gap between magnet and armature	1.0—1.45 mm (.039"—.057")
Control current is adjusted to	40±1 amp.
Test values apply in a temperature of about 20° C (68° F)	

Type

(for dynamo Bosch LJ/GG 200/6—2300 R6...7)	Bosch RS/UA 200/6/23
Balancing resistance AR	5.5—6.0 ohms
Control resistance W1	4.0—5.0 ohms
" " W2	6.0—7.0 ohms

Test values

Cut-out relay:	
Cut-in voltage	5.8—6.3 volts
Reverse current	4—9 amp.
Voltage control:	
Control voltage: unloaded	7.0—7.5 volts
Current control:	
Control current	47—51 amp.
Test values apply in a temperature of about 20° C (68° F)	

Starter motor

Voltage	6 volts
Earth connection	Negative terminal
Direction of rotation	Clockwise

Type

(with starter relay and Bendix drive) up to engine no. 43004	Auto-Lite MZ-4139.
Output	0.75 b.h.p.
Number of teeth on gear	9
Brushes, designation, 1 set=4 brushes	Auto-Lite MZ-2012AS
" " positive brushes (2)	Auto-Lite MZ-12
" " negative brushes (2)	Auto-Lite MZ-1034

Test values

Mechanical:

Armature axial clearance	0.15—1.15 mm (.0059"—.0453")
Brush spring tension	1.2—1.5 kg (2.65—3.3 lb)
Distance from face of mounting flange to edge of pinion	1.250—1.342" (31—34 mm)

Electrical:

No-load:

Check time (idling)	Max. 15 secs.
5.0 volts and max. 68 amp.	Min. 4000 r.p.m.

Locked starter motor:

2 volts and max. 280 amp.	Min. 0.6 kgm (4.4 lb.ft.)
--------------------------------	---------------------------

Starter relay:

Test values:

Current consumption of windings	2.9—3.3 amps at 6 volts
Closes at	3.0—4.0 volts
Opens at	0.5—1.25 volts

Type

(with solenoid switch) from engine no. 43005	Bosch EGD 0.6/6 AR19
Output	0.75 h.h.p.
Rated output (at —40° C, —40° F)	0.6 b.h.p.
Number of teeth on gear	9
Brushes, designation (4)	DSK 35/5

Test values

Mechanical:

Armature axial clearance	0.15—0.30 mm (.006"—.012")
Brush spring tension	0.8—0.9 kg (28—32 oz.)
Distance from pinion to ring gear	3 mm (.118")
Armature brake friction torque	3—5 kgcm (2.61—4.34 lb.in)
Gear idling torque	0.4—0.8 kgcm (.348—695 lb.in)

Electrical:

No-load:

Check time (idling)	Max. 15 secs.
5.5 volts 65—75 amp.	3500—4500 r.p.m.

Loaded starter motor:

4.5 volts and 260—280 amp.	750—850 r.p.m.
---------------------------------	----------------

Locked starter motor:

3.5 volts and 450—480 amp.	Min. 1.33 kgm (r.p.m. ∞)
---------------------------------	--------------------------

Solenoid switch, type	SSM 120/2
Test values:	
Current consumption of windings:	
Between connection 50 and body	9—12 amp. at 5.0 volts
Between connection 50 and 30	31—35 amp. at 5.0 volts
Operating voltage, closes	2.5—3.3 volts
opens	0.8—1.6 volts
Distance "a" (see fig. 38)	32.2 ± 0.1 mm (1.268 ± .004")

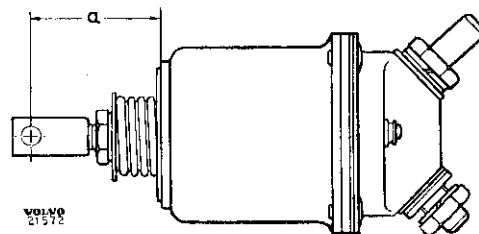

Fig. 38. Setting of Solenoid. (Iron core withdrawn).

Horn

Voltage	6 volts
---------------	---------

Type	Auto-Lite HW
-------------------	--------------

Air gap between magnet and armature:	
Horn with low tone	0.0495" (1.26 mm)
Horn with high tone	0.0400" (1.02 mm)
Adjusting screw set for	6.2 volts and 15 amp.

Type	Bosch FDE 6/1
-------------------	---------------

Air gap between magnet and armature	0.55—0.65 mm
---	--------------

Current consumption:	
Setting value	5.2—5.9 amp.
Limiting value	4.0—6.3 amp.
Voltage for armature attraction	Min. 4 volts
Voltage for full power	6—8 volts

Type	Bosch HO/FDF 6/3 (low tone)
-------------------	-----------------------------

Type	Bosch HO/FDF 6/4 (high tone)
-------------------	------------------------------

Air gap between magnet and armature:	
Low tone type	0.50—0.65 mm (.020"—.025")
High tone type	0.45—0.55 mm (.018"—.022")

Current consumption:	
Setting value, low tone type	4.7—5.3 amp.
high tone type	4.2—4.8 amp.
Limiting value, low tone type	3.5—5.6 amp.
high tone type	3.3—5.2 amp.

Voltage for armature attraction	4 volts
Voltage for full tone value	6—8 volts

Fuses

	Number	Type
P 44403 Chassis Nos. 1 20004; P 445 Chassis Nos. 1—1600	3	8 amp.
	1	25 "
P 44404 Chassis Nos. 12505 20004	2	8 "
	2	25 "
P 44403 Chassis Nos. 20005—28004, PV 445 C	5	8 "
	1	25 "
P 44404 Chassis Nos. 20005—28004	4	8 "
	2	25 "
P 44403 Chassis Nos. 28005—37004 and P 445 Chassis Nos. 1601 on-wards	4	8 "
	2	25 "
P 44404 Chassis Nos. 28005 37004	3	8 "
	3	25 "
P 44403 Chassis Nos. 37005—68955	4	8 "
	2	25 "
P 44404 Chassis Nos. 37005—68955	3	8 "
	3	25 "
P 44403 Chassis Nos. 68956 onwards	4	8 "
	2	25 "
P 44404 Chassis Nos. 68956 onwards	3	8 "
	3	25 "

Bulbs

The figures in the columns indicate: -	quantity	P 44403/4 Chassis Nos.						
		12504	12505—20004	20005—28004	28005—37004	37005—68955	68956—about 98000	about 98000—131917
Headlights						2 45/40 W BA 20 d		
Parking lights			2 2.4 W BA 9 s				2 1.5 W BA 9 s	2* 20/5 W BA 15 d spec.
Long duration parking						2 1.5 W BA 9 s		
Number plate lighting						1 5 W BA 15 s		
Stop and rear lights			2 20/3 W BA 15 d				2 20/2 W BA 15 d spec.	2* 20/5 W BA 15 d spec.
Instrument lights		3 1.5 W BA 9 s				2 2.4 W BA 9 s		
Traffic indicators		2 3 W S 5	Roof mounted 3 15 W BA 15 s	Side mounted 2 15 W BA 15 s		2 15 W BA 15 s	2 15 W S 8	**
Control lights for traffic indicators			1 2.4 W BA 9 s				2 2.4 W BA 9 s	
Control lights for headlights		1 2.4 W BA 9 s				1 1.5 W BA 9 s		
Interior lights		1 15 W BA 15 s	1 1.5 W BA 9 s		1 15 W BA 15 s		1 10 W S 8	

* as well as traffic indicators bulbs

** See parking lights and stop and rear lights respectively

Headlight beam adjustment

The beams are adjusted on a wall at a distance of 5 m (16 ft.).

Vertical adjustment (Distance "C" in general section, PV 10, fig. 68)	3" (75 mm) below headlight horizontal centre line.
Horizontal adjustment (Distance "B" in general section, PV 10, fig. 68)	3" (75 mm) outwards from the headlight vertical centre line.

Illustration I.

1. Left-hand stop and rear light
2. Right-hand stop and rear light
3. Connector
4. Fuel gauge tank unit
5. Left hand traffic indicator
6. Right hand traffic indicator
7. Roof light
8. Switch
9. Horn button
10. Instrument lighting switch
11. Fuel gauge
12. Ignition switch
13. Ammeter
14. Traffic indicator switch
15. Starting button
16. Traffic indicator control light
17. Instrument lights
18. Headlight control light
19. Ignition coil
20. Light switch
21. Fuse box
22. Battery
23. Relay
24. Connector
25. Contact for stop lights
26. Foot dipper switch
27. Starter motor
28. Ignition cable
29. Distributor
30. Horn
31. Sparking plugs
32. Parking lights
33. Headlights (dipped)
34. Headlights (full)
35. Left-hand headlight
36. Right-hand headlight
100. *Circuit for Bosch traffic indicators*
101. Right-hand traffic indicator
102. Left-hand traffic indicator
103. Control light
104. To fuse
105. Traffic indicator switch

Grön=Green
 Svart=Black
 Röd=Red
 Vit=White
 Blå=Blue
 Brons=Bronze

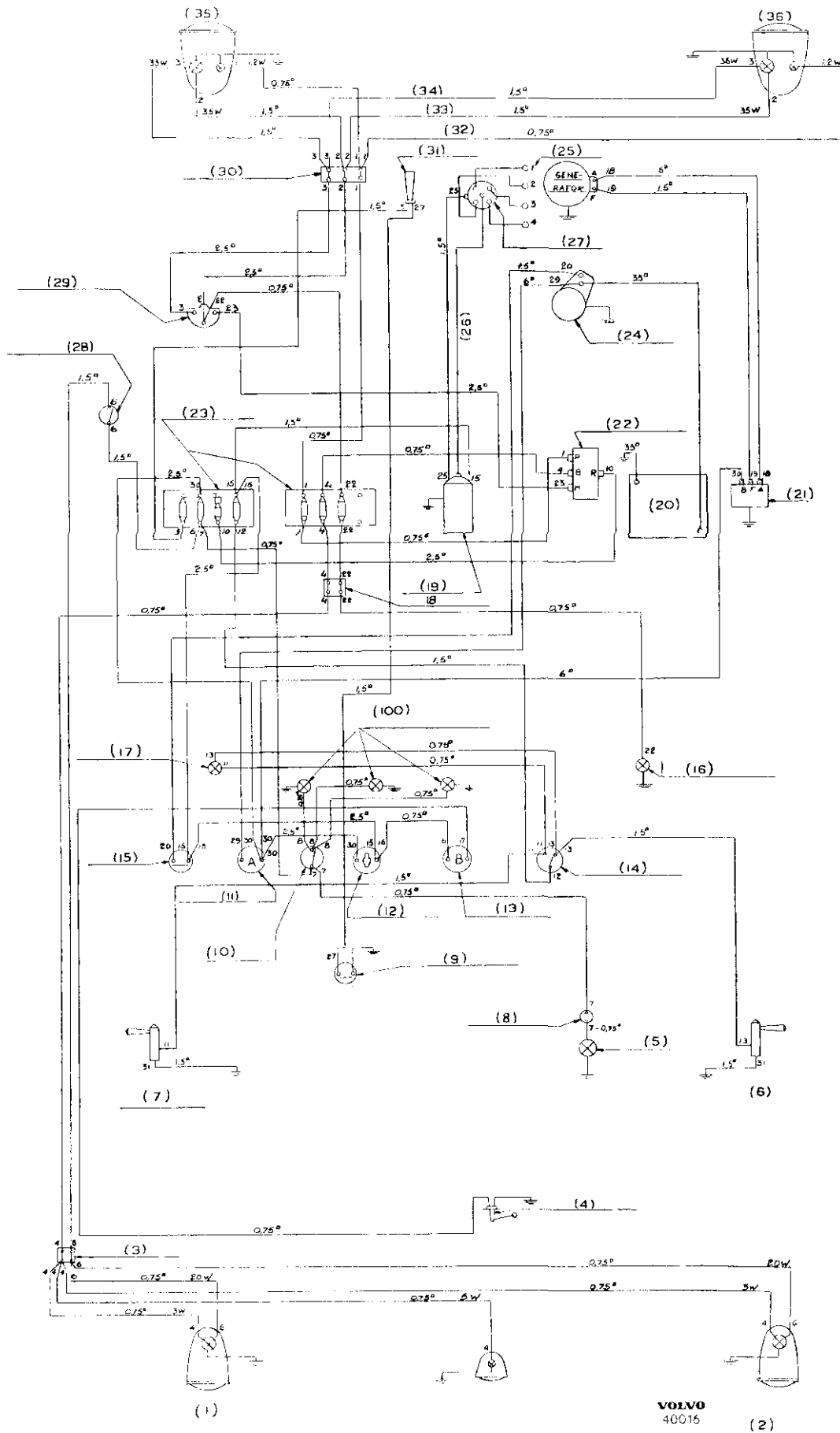

VOLVO
40015 (2)

Illustration II. Electrical circuits for P 44403/4
Chassis nos.: 4505, 4510, 4538 -- 4542, 4549, 4554—4555, 4557,
4559—4566, 4568, 4570, 4572—4780.

Illustration II.

1. Left-hand stop and rear light
2. Right-hand stop and rear light
3. Connector
4. Fuel gauge tank unit
5. Roof light
6. Right-hand traffic indicator
7. Left-hand traffic indicator
8. Switch
9. Horn button
10. Instrument lighting switch
11. Ammeter
12. Ignition switch
13. Fuel gauge
14. Traffic indicator switch
15. Starter button
16. Headlight control light
17. Traffic indicator control light
18. Connector
19. Ignition coil
20. Battery (6V, 85 amp. hrs.)
21. Relay
22. Light switch
23. Fuse box
24. Starter motor
25. Sparking plugs
26. Ignition cable
27. Distributor
28. Contact for stop lights
29. Foot dipper switch
30. Connector
31. Horn
32. Parking lights
33. Headlights (dipped)
34. Headlights (full)
35. Left-hand headlight
36. Right-hand headlight
100. Instrument lighting

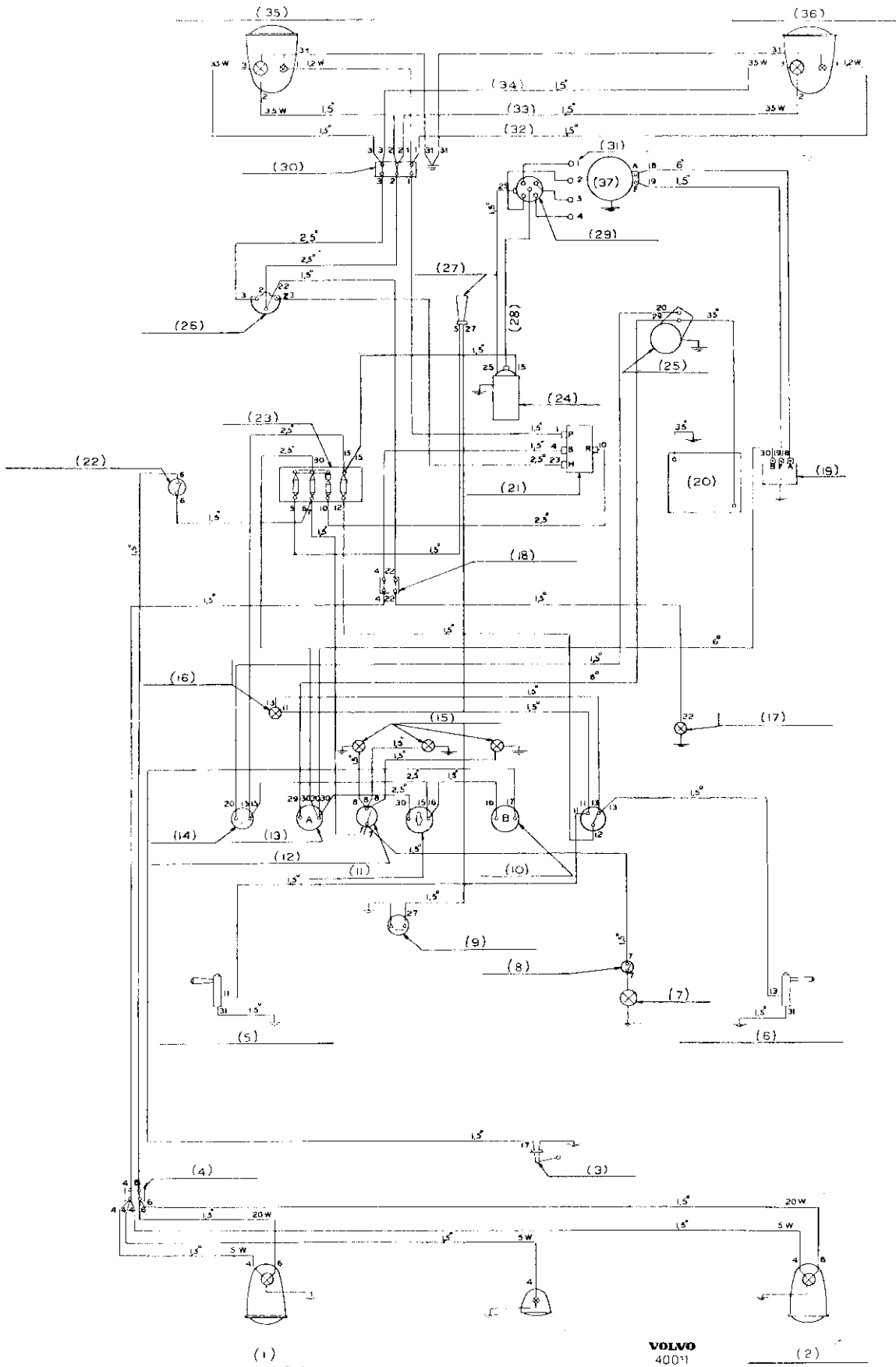

Illustration III. Electrical circuits for P 44403/4 and P 445
 Chassis nos.: P 44403/4: 5411—5499, 5510—5511, 7505—12504.
 P 445: 4—500.

Illustration III.

1. Left-hand stop and rear light
2. Right-hand stop and rear light
3. Fuel gauge tank unit
4. Connector
5. Left-hand traffic indicator
6. Right-hand traffic indicator
7. Roof light
8. Switch
9. Horn button
10. Fuel gauge
11. Ignition switch
12. Instrument lighting switch
13. Ammeter
14. Starting button
15. Instrument lights
16. Traffic indicator control light
17. Headlight control light
18. Connector
19. Relay
20. Battery
21. Light switch
22. Contact for stop lights
23. Fuse box
24. Ignition coil
25. Starter motor
26. Foot dipper switch
27. Horn
28. Ignition cable
29. Distributor
30. Connector
31. Sparking plugs
32. Parking lights
33. Headlights (dipped)
34. Headlights (full)
35. Left-hand headlight
36. Right-hand headlight
37. Dynamo

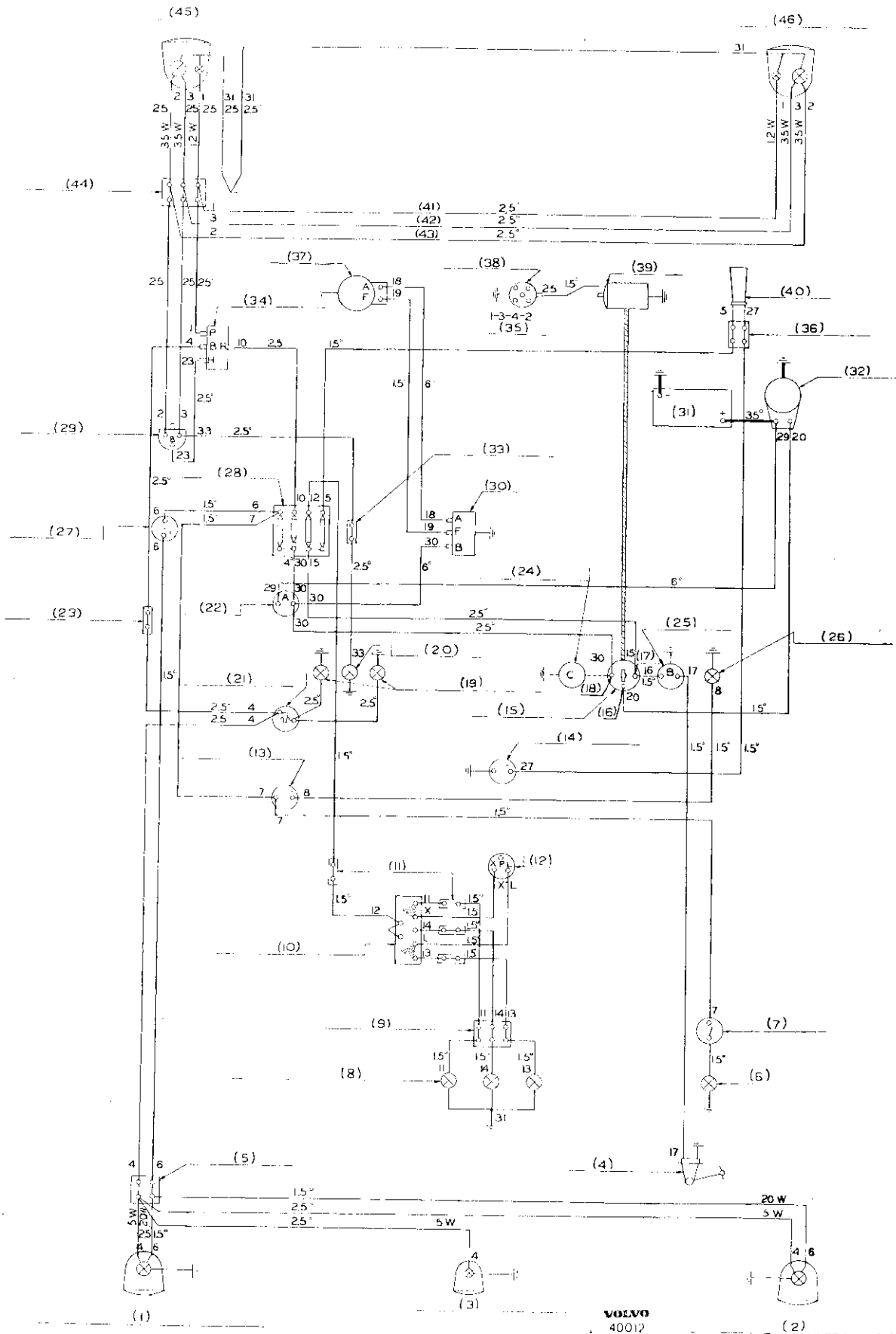

Illustration IV. Electrical circuits for P 44403/4 and P 445.

Chassis nos.: P 44403: 12505-20004.

P 445: 501-1600.

Illustration IV.

1. Left-hand stop and rear light
2. Right-hand stop and rear light
3. Number plate light
4. Fuel gauge tank unit
5. Connector
6. Roof light
7. Switch
8. Traffic indicators (blinkers)
9. Connector
10. Traffic indicator switch
11. Connector
12. Blinker relay
13. Door switch
14. Horn button
15. Ignition switch
16. "St" terminal
17. "Acc" terminal
18. "Am" terminal
19. Instrument lighting
20. Headlight control light
21. Instrument lighting rheostat
22. Ammeter
23. Connector
24. Cigarette lighter (not standard)
25. Fuel gauge
26. Ignition switch lighting
27. Contact for stop lights
28. Fuse box
29. Foot dipper switch
30. Relay
31. Battery
32. Starter motor
33. Connector
34. Light switch
35. Order of firing
36. Connector
37. Dynamo
38. Distributor
39. Ignition coil
40. Horn
41. Parking lights
42. Headlights (full)
43. Headlights (dipped)
44. Connector
45. Left-hand headlight
46. Right-hand headlight

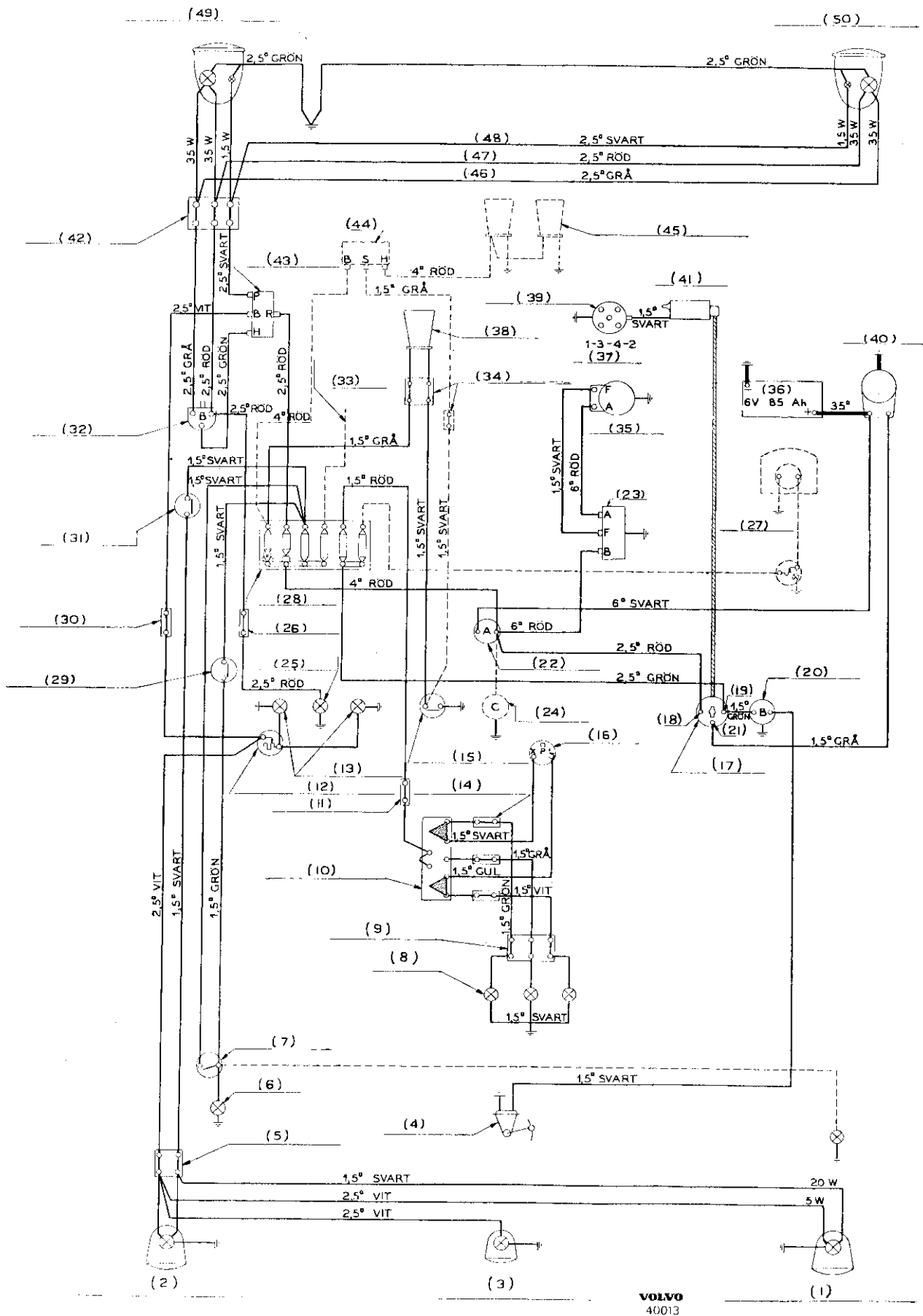

Illustration V. Electrical circuits for P 44403/4
 Chassis nos.: P 44403/4; 20005—26904.

Illustration V.

1. Right-hand stop and rear light
2. Left-hand stop and rear light
3. Number plate light
4. Fuel gauge tank unit
5. Connector
6. Roof light
7. Switch
8. Traffic indicators
9. Connector
10. Traffic indicator switch
11. Connector
12. Instrument lighting rheostat
13. Instrument lights
14. Connector
15. Horn button
16. Blinker relay
17. Ignition switch
18. "Am" terminal
19. "Acc" terminal
20. Fuel gauge
21. "St" terminal
22. Ammeter
23. Relay
24. Cigarette lighter (special model car only)
25. Headlight control light
26. Connector
27. Heater
28. Fuse box
29. Switch
30. Connector
31. Contact for stop lights
32. Foot dipper switch
33. Fog lights, spot light, reversing light
34. Connector
35. Dynamo
36. Battery
37. Order of firing
38. Horn
39. Distributor
40. Starter motor
41. Ignition coil
42. Connector
43. Light switch
44. Relay
45. Horn (special model car only)
46. Headlights (dipped)
47. Headlights (full)
48. Parking lights
49. Left-hand headlight
50. Right-hand headlight

Grön=Green
 Svart=Black
 Röd=Red
 Vit=White
 Grå=Grey
 Gul=Yellow

Illustration VI.

1. Right-hand stop and rear light
2. Left-hand stop and rear light
3. Number plate light
4. Fuel gauge tank unit
5. Switch
6. Roof light
7. Connector
8. Connector
9. Traffic indicator switch (side)
10. Traffic indicator switch (roof)
11. Connector
12. Connector
13. Connector
14. Ammeter
15. Horn button
16. Blinker relay
17. Instrument lighting rheostat
18. Instrument lights
19. Contact for stop lights
20. Door contact
21. Headlight control light
22. "Am" terminal
23. "St" terminal
24. Fuel gauge
25. "Acc" terminal
26. Cigarette lighter (special model car only)
27. Ignition switch
28. Heater motor
29. Defroster motor
30. Relay
31. Dynamo
32. Dipper foot switch
33. Fuse box
34. Connectors
35. Connector
36. Fog lights
37. Order of firing
38. Battery
39. Starter motor
40. Horn
41. Lighting switch
42. Distributor
43. Ignition coil
44. Lighting switch
45. Connector
46. Headlights (dipped)
47. Horn (special model car only)
48. Headlights (full)
49. Parking lights
50. Left-hand headlight
51. Right-hand headlight

Grön=Green
 Svart=Black
 Röd=Red
 Vit=White
 Blå=Blue
 Grå=Grey
 Gul=Yellow
 Brun=Brown

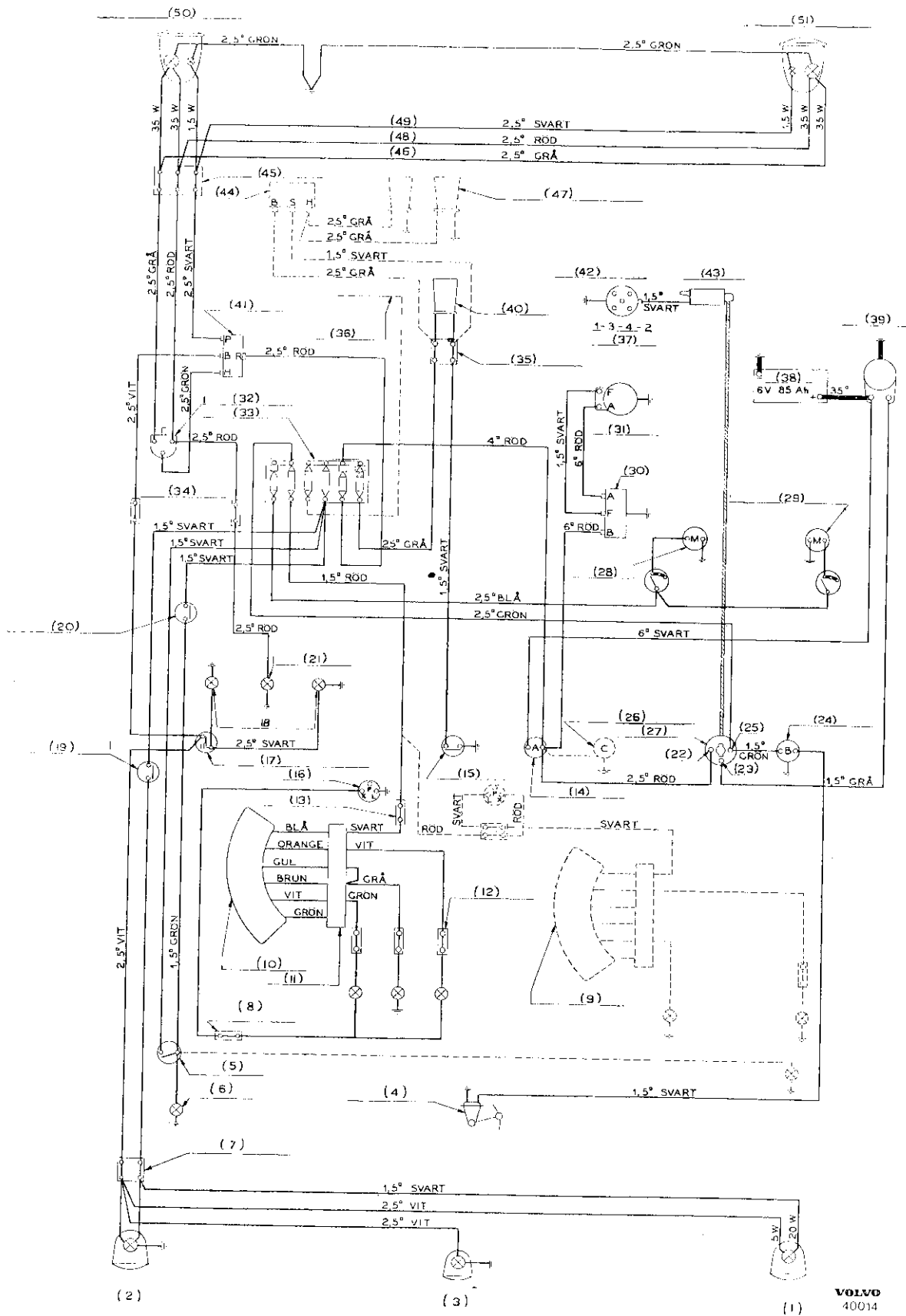

VOLVO
40014

Illustration VII. Electrical circuits for P 44403/4 and P 445

Chassis nos.: P 44403/4: 28005 - 37004

P 445: 1991 - 3037.

Illustration VII.

1. Right-hand stop and rear light
2. Left-hand stop and rear light
3. Number plate light
4. Fuel gauge tank unit
5. Switch
6. Roof light
7. Connector
8. Connector
9. Traffic indicator switch (side)
10. Traffic indicator switch (roof)
11. Connector
12. Connector
13. Connector
14. Ammeter
15. Horn button
16. Blinker relay
17. Instrument lighting rheostat
18. Instrument lights
19. Contact for stop lights
20. Door contact
21. Headlight control light
22. "Am" terminal
23. "St" terminal
24. Fuel gauge
25. "Acc" terminal
26. Cigarette lighter (special model car only)
27. Ignition switch
28. Heater motor
29. Defroster motor
30. Relay
31. Dynamo
32. Foot dipper switch
33. Fuse box
34. Connectors
35. Connectors
36. Fog lights
37. Order of firing
38. Battery
39. Starter motor
40. Horn
41. Lighting switch
42. Distributor
43. Ignition coil
44. Lighting switch
45. Connector
46. Headlights (dipped)
47. Horn (special model car only)
48. Headlights (full)
49. Parking lights
50. Left-hand headlight
51. Right-hand headlight

Grön=Green
 Svart=Black
 Röd=Red
 Vit=White
 Blå=Blue
 Grå=Grey
 Gul=Yellow
 Brun=Brown

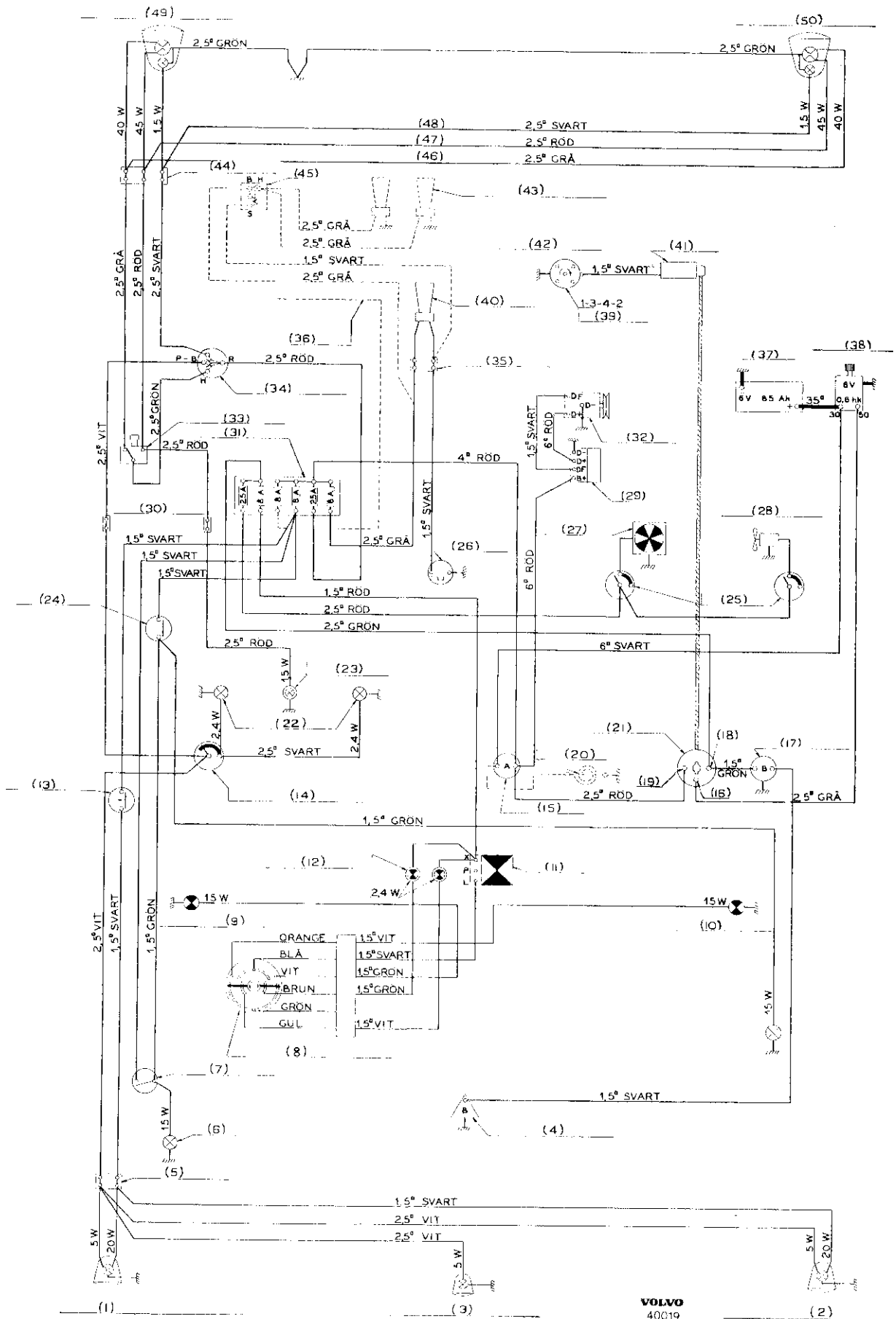

Illustration VIII. Electrical circuits for P 44403/4
 Chassis nos.: P 44403/4: 37005—46454.

Illustration VIII.

1. Left-hand stop and rear light
2. Right-hand stop and rear light
3. Number plate light
4. Fuel gauge tank unit
5. Connector
6. Roof light
7. Switch
8. Traffic indicator switch
9. Left-hand traffic indicator
10. Right-hand traffic indicator
11. Blinker
12. Traffic indicator control light
13. Brake contact
14. Instrument lighting rheostat
15. Ammeter
16. "St" terminal
17. Fuel gauge
18. "Acc" terminal
19. "Am" terminal
20. Cigarette lighter (special model car only)
21. Ignition switch
22. Instrument lighting
23. Headlight control light
24. Door contact
25. Adjustable rheostat switches
26. Horn button
27. Heater
28. Defroster fan
29. Relay
30. Connectors
31. Fuse box
32. Dynamo
33. Foot dipper switch
34. Light switch
35. Connector
36. Fog lights, spot light reversing light
37. Battery
38. Starter motor
39. Order of firing
40. Horn
41. Ignition coil
42. Distributor
43. Horn (special model car only)
44. Connector
45. Relay
46. Headlights (dipped)
47. Headlights (full)
48. Parking lights
49. Left-hand headlight
50. Right-hand headlight

Grön=Green
 Svart=Black
 Röd=Red
 Vit=White
 Blå=Blue
 Grå=Grey
 Gul=Yellow
 Brun=Brown

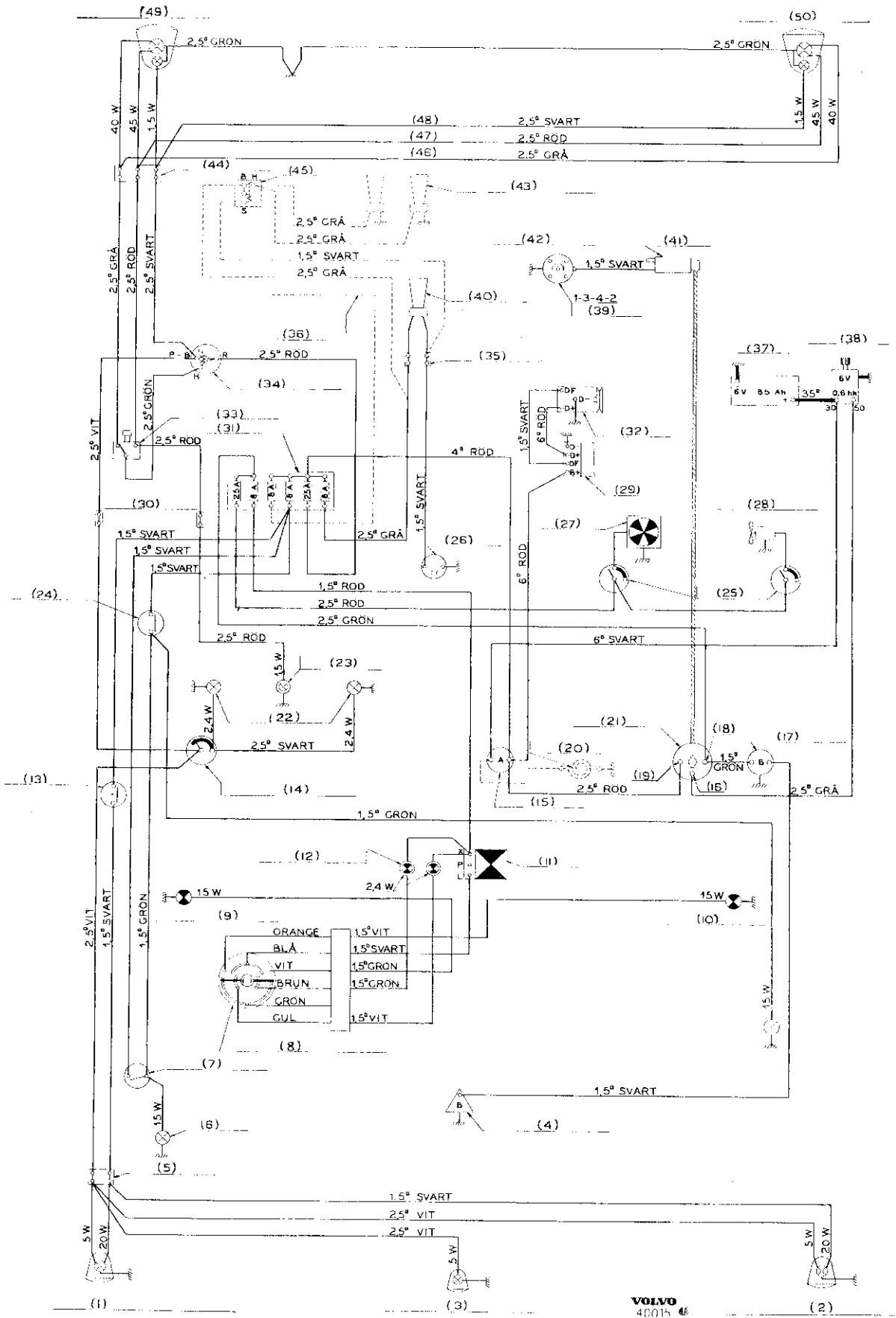

Illustration IX. Electrical circuits for P 44403/4
 Chassis nos.: P 44403/4: 46455- 56001.

Illustration IX.

1. Left-hand stop and rear light
2. Right-hand stop and rear light
3. Number plate light
4. Fuel gauge tank unit
5. Connector
6. Roof light
7. Switch
8. Traffic indicator switch
9. Left-hand blinker
10. Right-hand blinker
11. Blinker
12. Traffic indicator control light
13. Brake contact
14. Instrument lighting rheostat
15. Ammeter
16. "St" terminal
17. Fuel gauge
18. "Acc" terminal
19. "Am" terminal
20. Cigarette lighter (special model car only)
21. Ignition switch
22. Instrument lighting
23. Headlight control light
24. Door contact
25. Adjustable rheostat switches
26. Horn button
27. Heater
28. Defroster fan
29. Relay
30. Connectors
31. Fuse box
32. Dynamo
33. Foot dipper switch
34. Light switch
35. Connector
36. Fog lights, spot light reversing light
37. Battery
38. Starter motor
39. Order of firing
40. Horn
41. Ignition coil
42. Distributor
43. Horn (special model car only)
44. Connector
45. Relay
46. Headlights (dipped)
47. Headlights (full)
48. Parking lights
49. Left-hand headlight
50. Right-hand headlight

Grön= Green
 Svart= Black
 Röd= Red
 Vit= White
 Blå= Blue
 Grå= Grey
 Gul= Yellow
 Brun= Brown

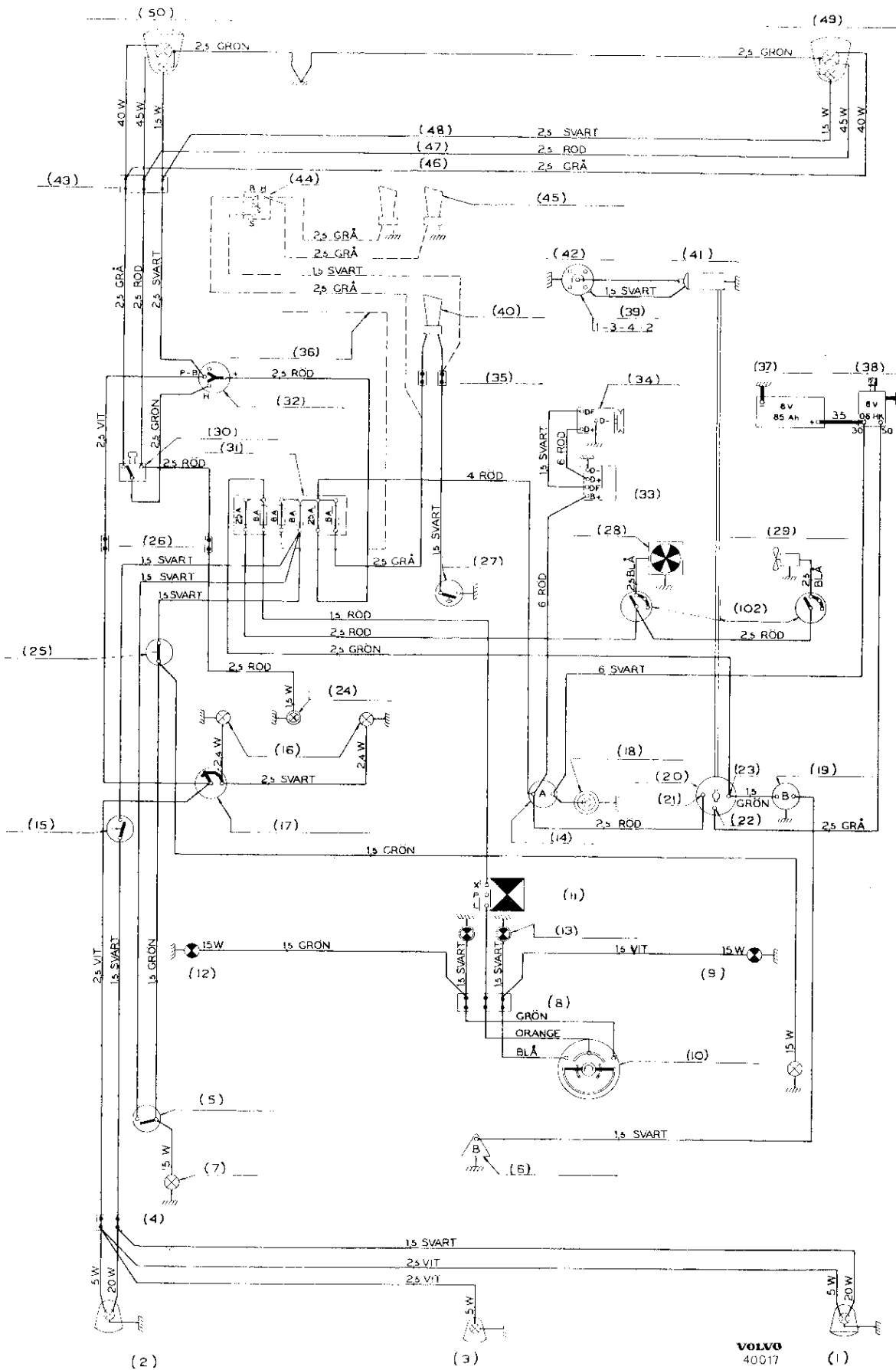

Illustration X. Electrical circuits for P 44403/4
 Chassis nos.: P 44403/4; 56005- 68955.

Illustration X.

1. Right-hand stop and rear light
2. Left-hand stop and rear light
3. Number plate light
4. Connector
5. Switch
6. Fuel gauge tank unit
7. Roof light
8. Connector
9. Right-hand blinker
10. Traffic indicator switch
11. Blinker
12. Left hand blinker
13. Blinker control lights
14. Ammeter
15. Brake contact
16. Instrument lighting
17. Instrument lighting rheostat control
18. Cigarette lighter
19. Fuel gauge
20. Ignition and starter switch
21. "Am" terminal
22. "St" terminal
23. "Acc" terminal
24. Headlight control light
25. Door contact
26. Connectors
27. Horn button
28. Heater
29. Defroster fan
30. Foot dipper switch
31. Fuse box
32. Light switch
33. Charging relay
34. Dynamo
35. Connectors
36. Fog lights, spot light, reversing light
37. Battery
38. Starter motor
39. Order of firing
40. Horn
41. Ignition coil
42. Distributor
43. Connector
44. Relay
45. Horn (special model car only)
46. Headlights (dipped)
47. Headlights (full)
48. Parking lights
49. Right-hand headlight
50. Left-hand headlight
102. Rheostat switches

Svart=Black
 Grön=Green
 Orange=Orange
 Blå=Blue
 Röd=Red
 Grå=Grey
 Vit=White

Illustration XI.

1. Right-hand stop and rear light
2. Left-hand stop and rear light
3. Number plate light
4. Connector
5. Fuel gauge tank unit
6. Direction indicator
7. Connector
8. Indicator light 2.4 W for traffic indicators
9. Right-hand blinker
10. Night parking light
11. Blinker mechanism
12. Switch
13. Ammeter
14. Rheostat switch for instrument lighting
15. Night parking light
16. Left-hand blinker
17. Brake contact
18. Ignition switch
19. Cigarette lighter
20. Fuel gauge
21. Indicator light for headlights
22. Roof light and switch
23. Rheostat switch
24. Instrument lighting
25. Door contact
26. Horn contact
27. Connectors
28. Heater
29. Charging regulator
30. To rear window fan
31. Foot dipper switch
32. Fuse box
33. Lighting switch
34. Connector
35. Dynamo
36. Battery
37. Starter motor
38. Distributor
39. Ignition coil
40. Horn
41. Horn --- special model car
42. Fog light, spotlight, reversing light
43. Order of firing
44. Relay
45. Headlights (dipped)
46. Headlights (full)
47. Parking lights
48. Connector
49. Left-hand headlight
50. Right-hand headlight

Svart=Black
 Grön=Green
 Orange=Orange
 Blå=Blue
 Röd=Red
 Grå=Grey
 Vit=White

Illustration XII.

1. Right-hand stop and rear light
2. Left-hand stop and rear light
3. Number plate light
4. Connector
5. Fuel gauge tank unit
6. Traffic indicator switch
7. Connector
8. Blinker control lights
9. Right-hand blinker
10. Left-hand blinker
11. Blinker mechanism
12. Ammeter
13. Instrument lighting rheostat control
14. Brake contact
15. Instrument lighting
16. Cigarette lighter
17. Ignition and starter switch
18. "Am" terminal
19. "St" terminal
20. "Acc" terminal
21. Fuel gauge
22. Headlight control light
23. Connector
24. Door contact
25. Roof light and switch
26. Horn button
27. Heater
28. Rheostat switch
29. To rear window fan
30. Foot dipper switch
31. Fuse box
32. Charging relay
33. Lighting switch
34. Connectors
35. Dynamo
36. Battery
37. Starter motor
38. Fog light, spot light, reversing light
39. Horn
40. Order of firing
41. Ignition coil
42. Distributor
43. Connector
44. Relay
45. Horn (special model car)
46. Headlights (dipped)
47. Headlights (full)
48. Parking lights
49. Right-hand headlight
50. Left-hand headlight

Svart=Black
 Grön=Green
 Orange=Orange
 Blå=Blue
 Röd=Red
 Grå=Grey
 Vit=White

Illustration XIII.

1. Right-hand stop and rear light
2. Left-hand stop and rear light
3. Number plate light
4. Fuel gauge tank unit
5. Connector
6. Traffic indicator switch
7. Blinker control lights
8. Blinker mechanism
9. Instrument lighting rheostat
10. Brake contact
11. Instrument lighting
12. Headlight control light
13. Ammeter
14. Cigarette lighter
15. Ignition and starter switch
16. "Am" terminal
17. "St" terminal
18. Fuel gauge
19. "Acc" terminal
20. Connector
21. Connector
22. Door contact
23. Roof light and switch
24. Horn button
25. Heater
26. Rheostat switch
27. To rear window fan
28. Foot dipper switch
29. Lighting switch
30. Fuse box
31. Charging relay
32. Starter motor
33. Battery
34. Dynamo
35. Connector
36. Relay
37. Horn (special model car)
38. Horn
39. Distributor
40. Order of firing
41. Ignition coil
42. Blinkers
43. Parking lights
44. Headlights (dipped)
45. Headlights (full)
46. Left blinker and parking light
47. Right blinker and parking light
48. Left headlight
49. Right headlight

Svart=Black
 Grön=Green
 Orange=Orange
 Blå=Blue
 Röd=Red
 Grå=Grey
 Vit=White
 Brun=Brown
 Gul=Yellow

Illustration XIV.

1. Right-hand rear light
2. Left-hand rear light
3. Number plate light
4. Stop light and blinker
5. Rear light
6. Rear light
7. Stop light and blinker
8. Connector
9. Roof light
10. Switch
11. Traffic indicator switch
12. Fuel gauge tank unit
13. Connector
14. Right-hand blinker
15. Left-hand blinker
16. Blinker control lights
17. Blinker mechanism
18. Brake contact
19. Instrument lighting rheostat
20. Instrument lighting
21. Door contact
22. Headlight control light
23. Ammeter
24. Cigarette lighter
25. Ignition and starter switch
26. "Am" terminal
27. "St" terminal
28. "Acc" terminal
29. Fuel gauge
30. Foot dipper switch
31. Connector
32. Lighting switch
33. Fuse box
34. Horn button
35. Rheostat switch
36. Heater
37. Rheostat switch
38. Defroster fan
39. Starter motor
40. Battery
41. Charging relay
42. Dynamo
43. Connector
44. Horn
45. Distributor
46. Ignition coil
47. Order of firing, 1-3-4-2
48. Fog light, spot light, reversing light
49. Connector
50. Headlights (dipped)
51. Headlights (full)
52. Parking lights
53. Left-hand headlight
54. Right-hand headlight

Illustration XV.

1. Right-hand rear light
2. Left-hand rear light
3. Number plate light
4. Stop light and blinker
5. Rear light
6. Rear light
7. Stop light and blinker
8. Connector
9. Roof light
10. Switch
11. Traffic indicator switch
12. Door contact
13. Roof light, rear
14. Fuel gauge tank unit
15. Connector
16. Right-hand blinker
17. Left-hand blinker
18. Blinker control lights
19. Blinker mechanism
20. Fuel gauge
21. "Acc" terminal
22. "St" terminal
23. "Am" terminal
24. Ignition and starter switch
25. Cigarette lighter
26. Ammeter
27. Instrument lighting rheostat
28. Brake contact
29. Instrument lighting
30. Headlight control light
31. Door contact
32. Connector
33. Horn button
34. Rheostat switch
35. Heater
36. Rheostat switch
37. Defroster fan
38. Foot dipper switch
39. Fuse box
40. Charging relay
41. Starter motor
42. Battery
43. Dynamo
44. Connector
45. Lighting switch
46. Connector
47. Ignition coil
48. Order of firing, 1-3-4-2
49. Distributor
50. Horn
51. Fog light, spot light and reversing light
52. Headlights (dipped)
53. Headlights (full)
54. Parking lights
55. Left-hand headlight
56. Right-hand headlight

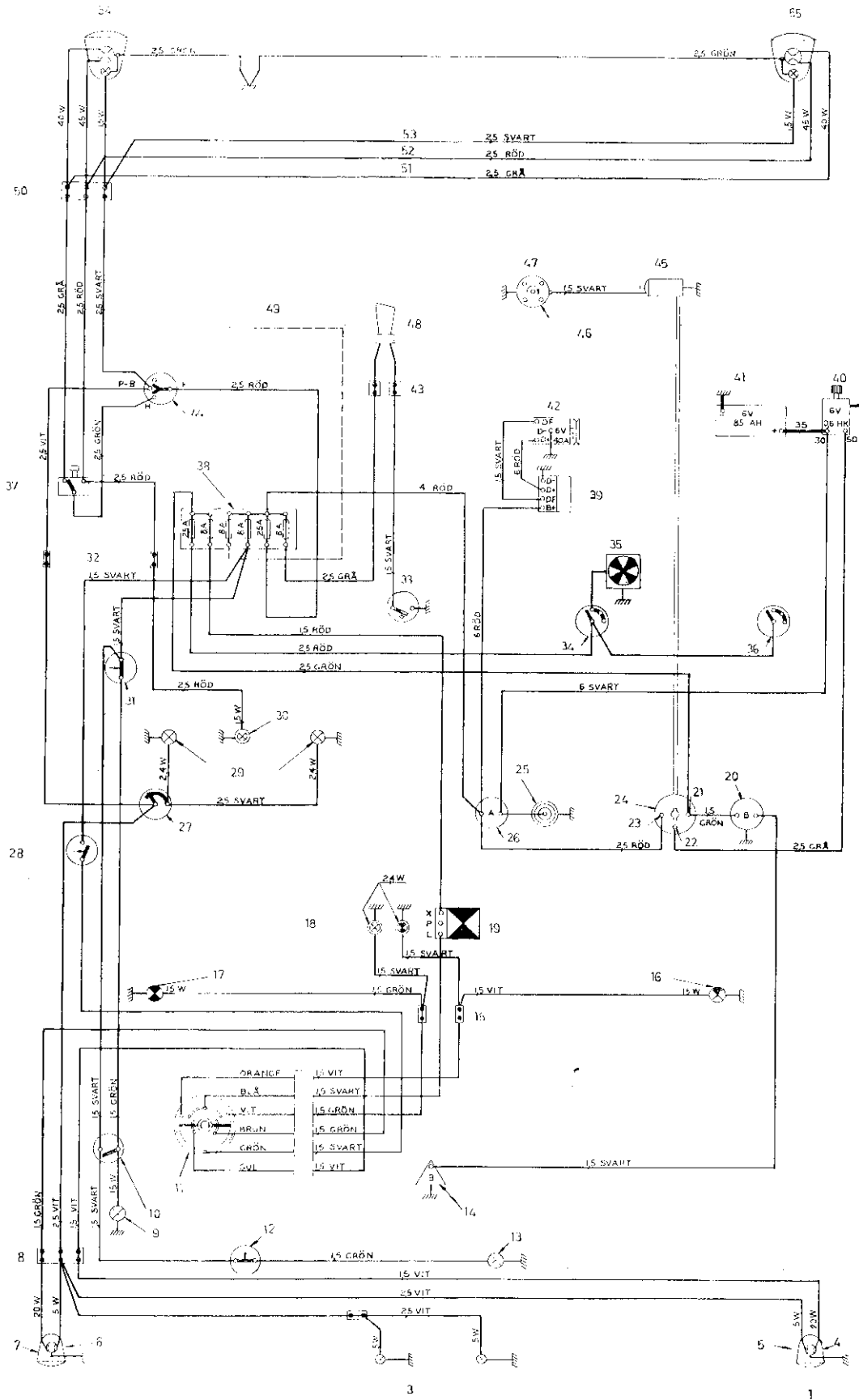

Illustration XVI. Electrical circuits for P 445

Chassis nos. P 44501: 3528-3585

P 44505: 1334-2069

P 44506: 6390-8155

P 44507/08: 1184-2996

Illustration XVI.

1. Right-hand rear light
2. Left-hand rear light
3. Number plate light
4. Stop light and blinker
5. Rear light
6. Rear light
7. Stop light and blinker
8. Connector
9. Roof light
10. Switch
11. Traffic indicator switch
12. Door contact
13. Roof light, rear
14. Fuel gauge tank unit
15. Connector
16. Right-hand blinker
17. Left-hand blinker
18. Blinker control lights
19. Blinker mechanism
20. Fuel gauge
21. "Acc" terminal
22. "St" terminal
23. "Am" terminal
24. Ignition and starter switch
25. Cigarette lighter
26. Ammeter
27. Instrument lighting rheostat
28. Brake contact
29. Instrument lighting
30. Headlight control light
31. Door contact
32. Connector
33. Horn button
34. Rheostat switch
35. Heater
36. Rheostat switch
37. Foot dipper switch
38. Fuse box
39. Charging relay
40. Starter motor
41. Battery
42. Dynamo
43. Connector
44. Lighting switch
45. Ignition coil
46. Order of firing
47. Distributor
48. Horn
49. Fog light, spot light and reversing light
50. Connector
51. Headlights (dipped)
52. Headlights (full)
53. Parking lights
54. Left-hand headlight
55. Right-hand headlight

Grön=Green
 Svart=Black
 Röd=Red
 Vit=White
 Blå=Blue
 Grå=Grey
 Gul=Yellow
 Brun=Brown

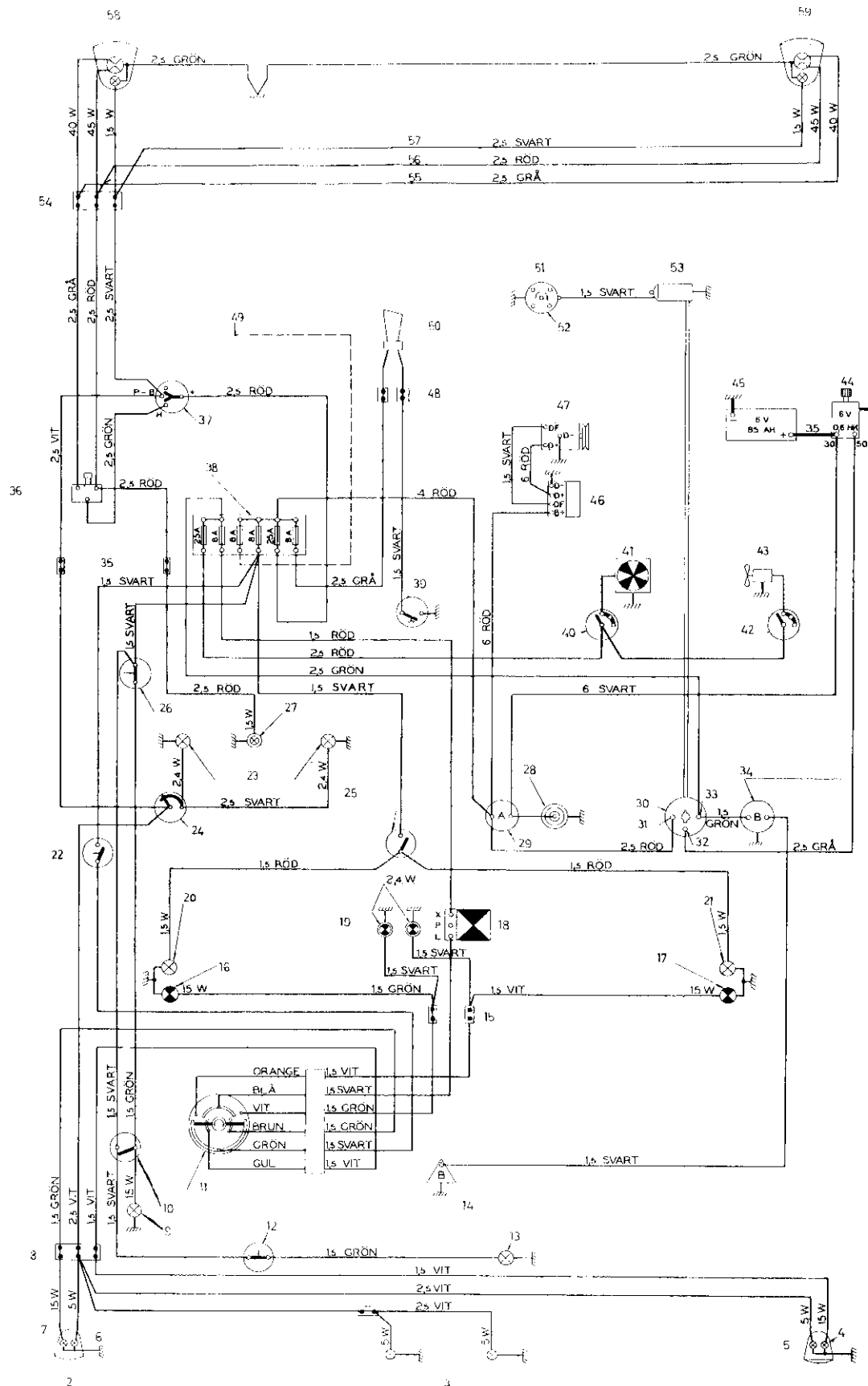

Illustration XVII. Electrical circuits for P 445

Chassis nos. P 44501: 3586—
 P 44505: 2070 —
 P 44506: 8156—
 P 44507— 08: 2997—

Illustration XVII.

1. Right-hand rear light
2. Left-hand rear light
3. Number plate light
4. Stop light and blinker
5. Rear light
6. Rear light
7. Stop light and blinker
8. Connector
9. Roof light
10. Switch
11. Traffic indicator switch
12. Door contact
13. Roof light, rear
14. Fuel gauge tank unit
15. Connector
16. Left-hand blinker
17. Right-hand blinker
18. Blinker mechanism
19. Blinker control lights
20. Parking light
21. Parking light
22. Brake contact
23. Instrument lighting
24. Instrument lighting rheostat
25. Switch
26. Door contact
27. Headlight control light
28. Cigarette lighter
29. Ammeter
30. Ignition and starter switch
31. "Am" terminal
32. "St" terminal
33. "Ace" terminal
34. Fuel gauge
35. Connector
36. Foot dipper switch
37. Lighting switch
38. Fuse box
39. Horn button
40. Rheostat switch
41. Heater
42. Rheostat switch
43. Defroster fan
44. Starter motor
45. Battery
46. Charging relay
47. Dynamo
48. Connector
49. Fog light, spot light and reversing light
50. Horn
51. Distributor
52. Order of firing
53. Ignition coil
54. Connector
55. Headlights (dipped)
56. Headlights (full)
57. Parking lights
58. Left-hand headlight
59. Right-hand headlight

Grön=Green
 Svart=Black
 Röd=Red
 Vit=White
 Blå=Blue
 Grå=Grey
 Gul=Yellow
 Brun=Brown