

SERVICE MANUAL

CARS AND VANS

P

Part 1

ENGINE

B 16 A

Export Service Department

AKTIEBOLAGET

VOLVO

GÖTEBORG . SWEDEN

CONTENTS

Description	1
General	1
Crankshaft	2
Bearings	3
Pistons	3
Lubricating system	4
Fuel system	5
Air cleaner	8
Cooling system	9
Repair instructions	10
Compression test	10
Tuning up the engine	10
Valve grinding	11, 25
Removing the engine	14
Disassembling the engine	15
Cylinder block	16
Cylinder head	17, 24
Crankshaft	17
Main and connecting rod bearings	18
Pistons, piston rings	20
Connecting rods	22
Camshaft gear	13, 23
Valve springs	24
Valve seat grinding	25
Valve clearance	27
Oil pump	28
Oil cleaner	29
Ignition setting	30
Carburetor	31
Fuel pump	34
Water pump	35
Thermostat	37
Radiator	37
Anti-freeze	38
Reassembling the engine	39
Fitting the engine in the car	39
Fault tracing	41
Special tools	46
Specifications	48
Tightening torques	54

DESCRIPTION

General

Engines with type designation B 16 A are four-cylinder, overhead valve carburetor engines.

The bore is 79.37 mm (3.125") stroke 80 mm (3.15"), capacity 1.58 liters (96.4 cu. in.) and compression ratio 7.4:1. The compression pressure is 9.5—10.5 kg/cm² (135—150 lb/sq. in.) at 200 r.p.m.

The engine develops an output of 66 b.h.p. (SAE) at 4500 r.p.m. and a maximum torque of 11.8 kgm (87 lb. ft.) at 2500 r.p.m. The appearance of the engine is shown in Fig. 1 and Fig. 2. The output and torque curves are shown in Fig. 3. Longitudinal and transverse cross-sections are shown in the illustration at the end of this book.

Cylinder head

The cylinder head (17 in the illustration at the

end of the book) which is made of special-alloy cast-iron, is fitted with cooling water jackets. The combustion chambers are connected with the carburetor and exhaust manifold through channels in the cylinder head. The height from the contact surface with the block to the level of the cylinder head nuts is 99 mm (3.90").

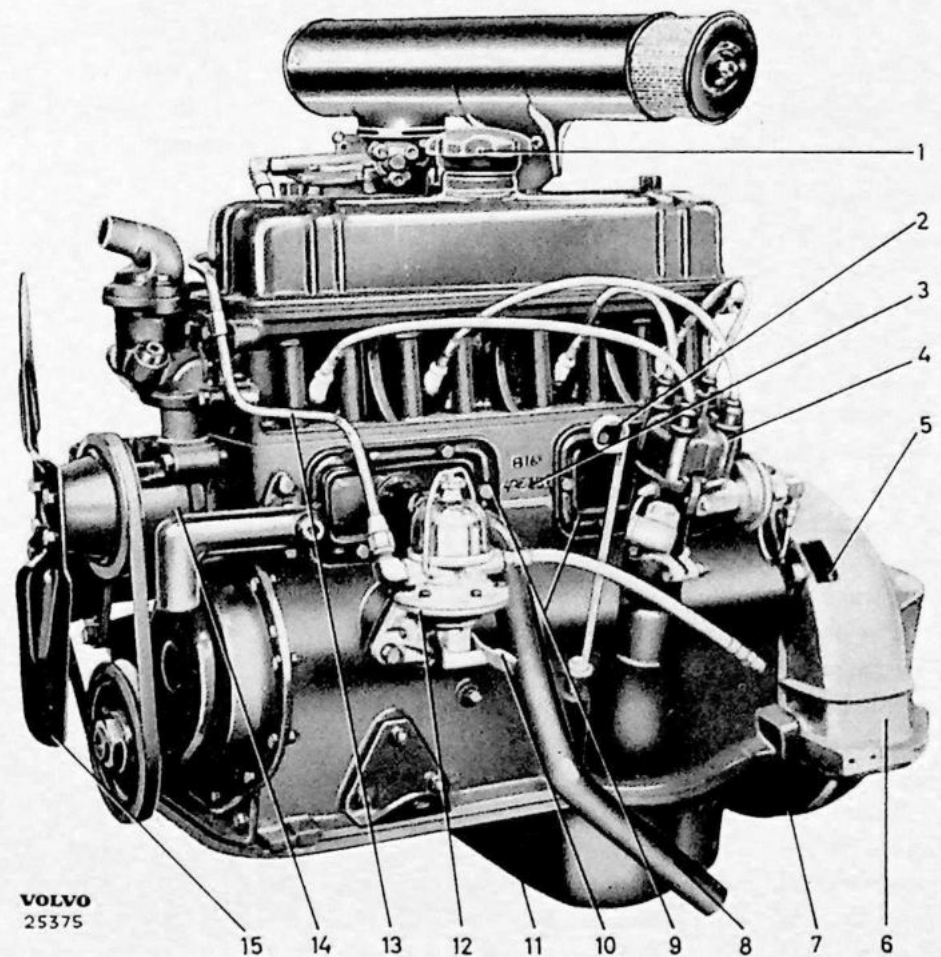
Cylinder block

The cylinder block (19) is integrally cast of special cast-iron. It is designed so that on the right-hand side an oil cleaner — of the full-flow type — is in direct connection with the block. The oil channel from the pump terminates on the outside of the cleaner element, the channel to the block on the inside of the cleaner element, this obviating the necessity of external oil lines.

The cylinders, which are drilled directly in the block, have a bore of 79.37 mm (3.125").

Fig. 1. The engine
(distributor side).

1. Oil filler cap
2. Dipstick
3. Engine serial number (only late production)
4. Distributor
5. Inspection hole for ignition timing
6. Flywheel housing
7. Cover plate
8. Crankcase breather pipe
9. Inspection cover
10. Hand primer pump
11. Oil pan
12. Fuel pump
13. Fuel line
14. Water pump
15. Fan



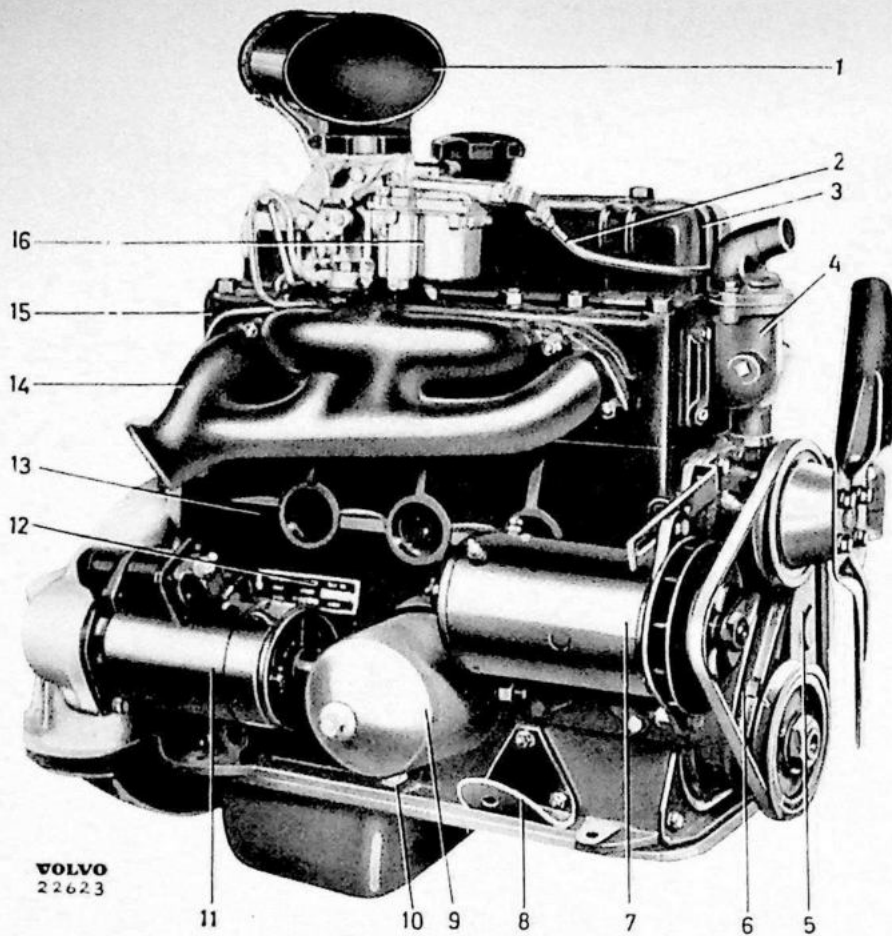


Fig. 2. The engine (carburetor side).

1. Air cleaner
2. Fuel line
3. Rocker arm cover
4. Thermostat housing
5. Timing gear casing
6. TDC mark
7. Generator
8. Engine mounting
9. Oil cleaner
10. Relief valve
11. Starter motor
12. Engine serial number (early production)
13. Cylinder block
14. Exhaust manifold
15. Cylinder head
16. Carburetor

Crankshaft

The crankshaft (37) is made of drop-forged steel with precision ground main and connecting rod bearing journals. It is statically and dynamically balanced and carried in three main bearings in the upper part of the crankcase. The rear bearing journal is fitted with flanges for axial location. In addition to standard sizes, undersize bearing shells are also available to provide the correct clearance without shaving or filing even after the bearing journals have been re-ground. The seal at the front end of the crankshaft is in the form of a metal washer, an oil slinger, and a felt washer.

The seal at the rear end of the crankshaft is in the form of an oil slinger fitted directly on the crankshaft and this returns the oil to the crankcase. Behind this oil slinger there is also a felt seal around the crankshaft.

Between the oil slinger and the felt ring at both ends of the crankshaft there is a limited cavity in which the oil is caught up. In the lower edge of this cavity there are drain holes through which the oil runs back to the oil pan. The rear seal on

early production units does not have this cavity design.

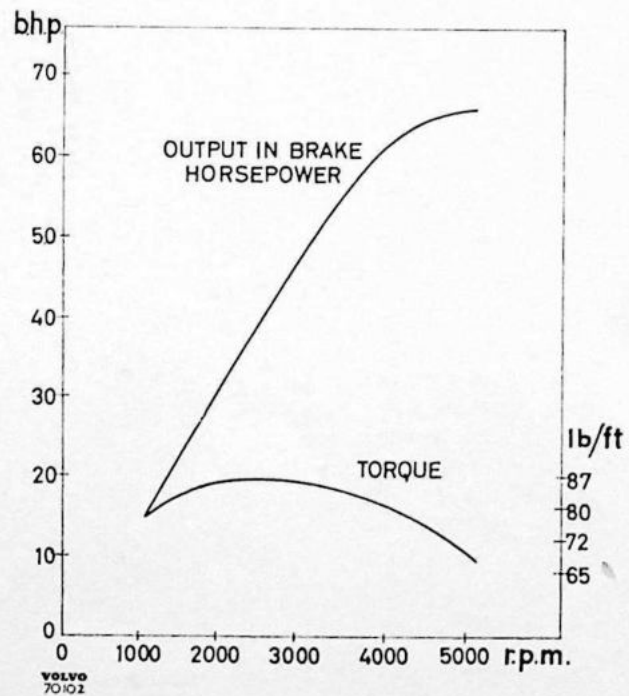


Fig. 3. Output and torque curves (SAE).

Main bearings and connecting rod bearings

The bearing shells for the connecting rods (38) are covered with bearing metal consisting of a special lead-bronze alloy. The bearing metal on the main bearing shells (35) consists of white metal of a special type, with the exception of the guide bearing (31) where the bearing metal is normal white metal.

Camshaft

The camshaft (22) is made of cast steel or forged steel and has ground cams and bearing journals. The axial movements of the camshaft are limited by a washer located on the front end between the forward bearing journal and the camshaft gear. A cast oil pump gear must be used together with a cast camshaft, and a forged gear with a forged camshaft.

Pistons and piston rings

The pistons (36) are made of light-alloy covered with a thin coating of tin. The piston pin hole is offset from the centre axis of the pistons. On the top of each piston there is a letter stamped showing the measurement of the piston (only on standard sizes) and an arrow showing which side of the piston must face forward.

There are two compression rings and one oil control ring on each piston. Both the compression rings are bevelled on the inside and this bevel should be turned to face upwards. The upper compression ring on each piston is chromed.

Connecting rods

The connecting rods (69) are made of drop-forged steel and are of the H-section type to ensure outstanding rigidity in combination with low weight.

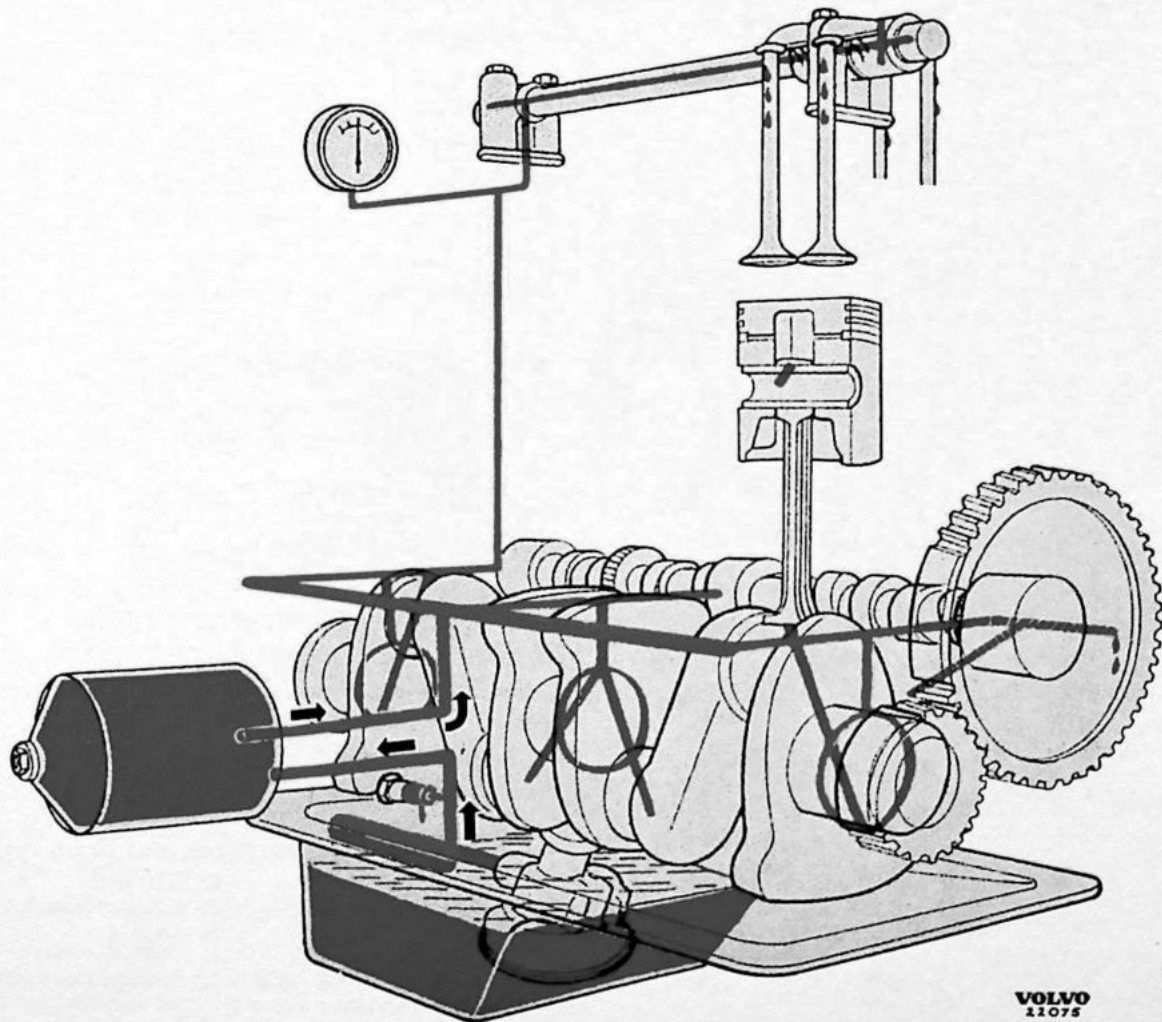


Fig. 4. Lubricating system.

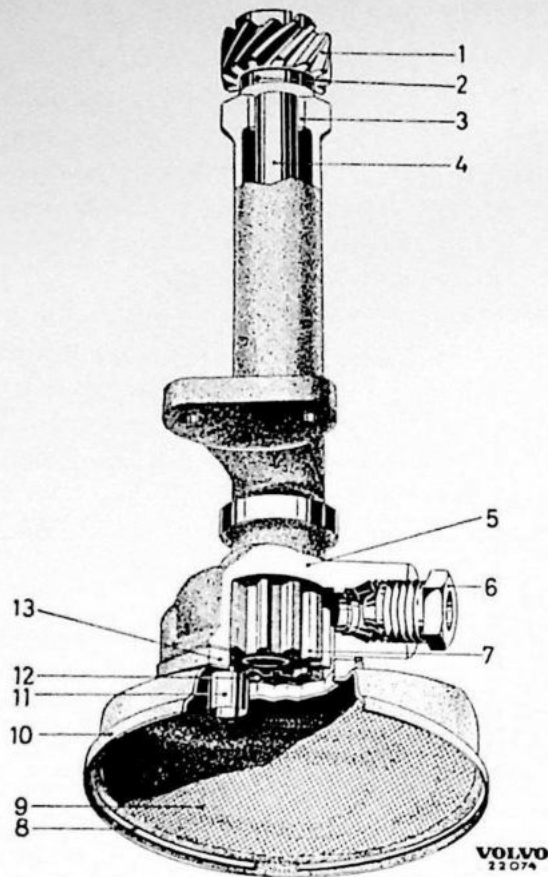


Fig. 5. Oil pump.

- | | |
|-----------------------------|----------------------|
| 1. Drive gear | 3. Lock ring |
| 2. Lock pin | 9. Strainer |
| 3. Bushing | 10. Strainer housing |
| 4. Shaft | 11. Inlet |
| 5. Housing | 12. Gear (driving) |
| 6. Pressure pipe connection | 13. Cover |
| 7. Gear (driven) | |

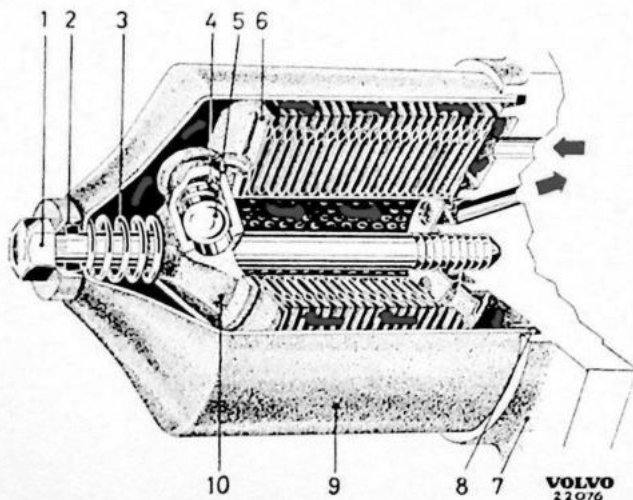


Fig. 6. AC oil cleaner.

- | | |
|--------------------|-------------------|
| 1. Bolt | 6. Insert |
| 2. Washer and seal | 7. Cylinder block |
| 3. Spring | 8. Gasket |
| 4. Valve spring | 9. Housing |
| 5. Valve ball | 10. Valve housing |

Since the cylinder bores are not located exactly over the connecting rod bearing journals but offset rather relative to the longitudinal axis of the engine, the shanks of the connecting rods are also offset relative to the centre line of the bearing surface.

The connecting rod bearings on the crankshaft consist of replaceable bearing shells and the piston pins are carried in the connecting rods by precision machined bushings. The connecting rods are divided up into various weight classes, these being marked by means of various letters. All the connecting rods in the engine should have the same letter marked on them ensuring that they are in the same weight class.

Valves

The valves (53) are made of special steel. The face of the disc on each valve has a spherical depression. This decreases the weight of the valves which is a great advantage, particularly at high engine speeds. This recess also provides a certain elasticity and improves sealing.

Lubricating system

The engine has a complete pressure lubricating system which is shown in principle in Fig. 4. The pressure in the system is produced by a gear pump, Fig. 5, which forces the oil through drillings out to the lubricating points. The oil

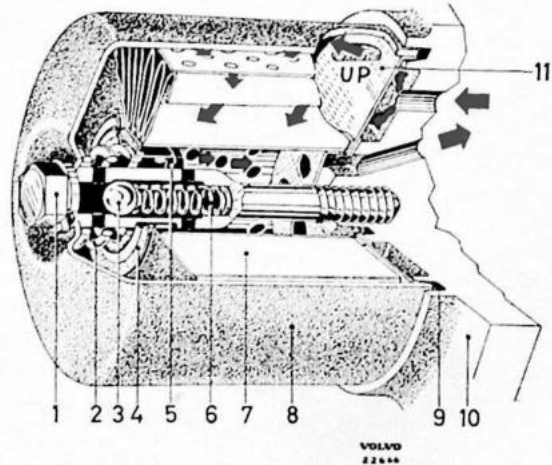


Fig. 7. Oil cleaner, Mann and Fram types.

- | | |
|---|--|
| 1. Bolt with washer | 7. Element |
| 2. Spring | 8. Cleaner housing |
| 3. Valve ball | 9. Gasket |
| 4. Sealing sleeve | 10. Cylinder block |
| 5. Washer (MANN). (On Fram oil cleaners there is only a lock ring inside the sealing sleeve.) | 11. Intermediary plate, fitted on late production units (independent of make). |
| 6. Valve spring | |

cleaner is of the full-flow type and all the oil being forced out to the lubricating points must first pass through the cleaner.

A relief valve in the system prevents the oil pressure from attaining excessively high values.

The oil cleaner, Fig. 6 and Fig. 7 is connected directly through the right-hand side of the cylinder block and there are no external oil lines whatsoever. Inlets and outlets to the oil cleaner are in the form of channels in the block itself. The filter insert consists of a replaceable paper element. The cleaner is fitted with a relief valve which permits the oil to by-pass the actual filter element if the resistance to flow in the element should exceed 0.9—1.3 kg/cm² (13—19 lb/sq.in.). The different makes of oil cleaner are interchangeable and similar in principle. The intermediary plate (11, Fig. 7) maintains the oil level in the cleaner as high as possible after the engine has been stopped, thus ensuring full oil pressure as soon as possible after the engine is started again.

Ignition system

Distributor

The distributor in the electrical system is a Bosch unit and this is fitted with both centrifugal and vacuum regulators.

Fuel system

Carburetor

The engine is fitted with a Zenith down-draught carburetor with type designation 34 VN. The appearance of this carburetor is shown in Fig. 8 and Fig. 9.

The flow of fuel is controlled by means of fixed jets which are fitted in an emulsion block with a beak projecting into the throat of the carburetor. In the emulsion block there are also air channels whereby fuel can be mixed with a certain amount of air at an early stage. The carburetor has a manual choke, rapid idling device, acceleration pump and economiser valve. The function of the carburetor are described under the following headings.

1. Float system.
2. Choke device and rapid idling.
3. Idling system.
4. Main and compensating jets. Economiser valve.
5. Acceleration pump.

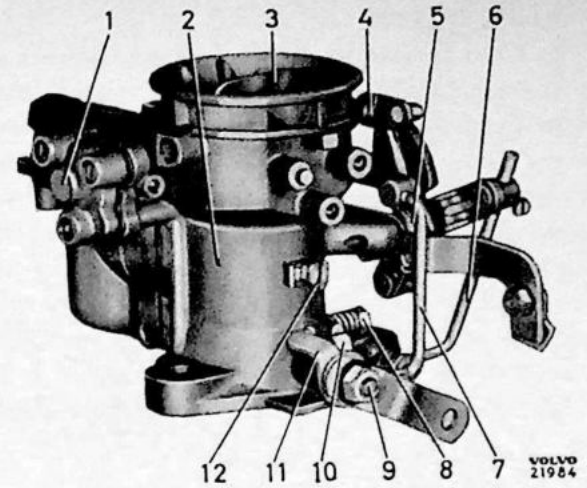


Fig. 8. The carburetor (left side).

- | | |
|-------------------------------|-------------------------------------|
| 1. Economiser valve | 8. Idle adjusting screw |
| 2. Carburetor housing | 9. Throttle shaft |
| 3. Choke flap | 10. Stop on lever |
| 4. Spring for choke flap | 11. Short lever for throttle |
| 5. Spring for lever | 12. Adjuster screw for venturi pump |
| 6. Link for rapid idling | |
| 7. Link for acceleration pump | |

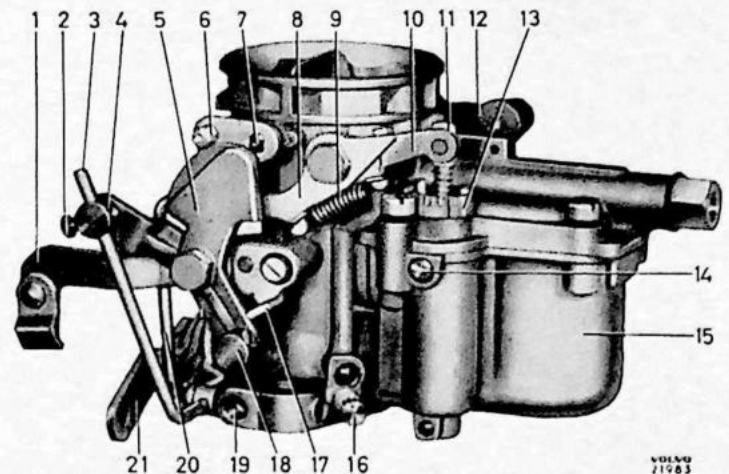


Fig. 9. The carburetor (right side).

- | | |
|---|--|
| 1. Bracket | 12. Economiser valve |
| 2. Screw for rapid idling adjustment | 13. Washer for adjustment of accelerator pump stroke |
| 3. Link for rapid idling | 14. Plunger check screw |
| 4. Attachment | 15. Float bowl |
| 5. Lever for choke flap (with cam) | 16. Idle fuel adjusting screw |
| 6. Choke lever | 17. Stop |
| 7. Choke spindle | 18. Attachment for choke control |
| 8. Rear part of acceleration pump lever | 19. Hole for vacuum line |
| 9. Spring | 20. Acceleration pump rod |
| 10. Forward part of acceleration pump lever | 21. Throttle lever |
| 11. Pump plunger rod | |

1. Float system

The float is used to maintain the fuel level at the correct height. When the fuel reaches this height the float (7, Fig. 10) moves upwards and presses the needle in the valve (2) against the seat through the medium of the float arm whereby the supply of fuel is cut off. When the float starts to sink, the same procedure is repeated but in the opposite direction. The float bowl is ventilated by means of a hole (3). Early production floats are made of brass and have a separate arm. Late production units have nylon floats with a fixed arm.

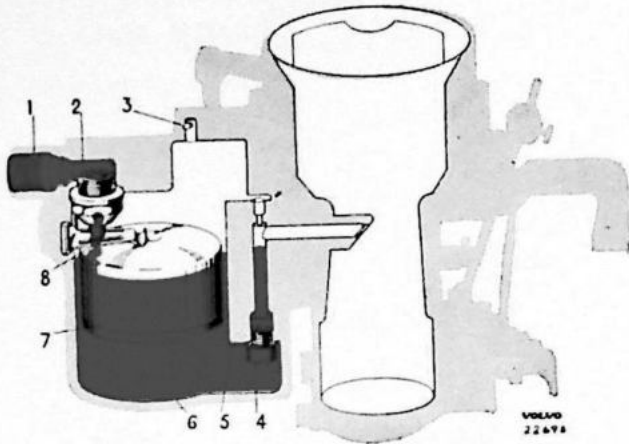


Fig. 10. Float system.

- | | |
|----------------------------|-------------------|
| 1. Fuel inlet | 5. Emulsion block |
| 2. Float valve with washer | 6. Float bowl |
| 3. Ventilation hole | 7. Float |
| 4. Jet | 8. Arm |

2. Choke device and rapid idling

In order to enrich the fuel/air mixture when starting a cold engine there is a choke device which is operated from a control on the instrument panel. When this control knob is pulled out for starting it influences the cam-formed lever (12, Fig. 11). The choke flap (15) is influenced by the spring (14) on the choke spindle so that it closes resulting in a more powerful vacuum and thereby a greater fuel flow. When the engine has started and the degree of vacuum has increased, the choke can open to a certain extent since a closing force is obtained from a spring on the choke spindle. This avoids an excessively rich fuel mixture.

The choke lever also influences the throttle through the link (11). This means that the throttle will open at the same time as the choke

is closed. The degree to which the throttle is opened relative to the choke closing is determined by various settings of the link and screw (10). By means of this rapid idling device, the driver can give the engine higher speed during the warming-up period and prevent the engine from stalling.

3. Idling system

When the engine is idling, the throttle is almost completely closed (adjusted by means of a screw 19, Fig. 12) whereby the vacuum around and under the throttle is large. There is then a strong suction effect through the idling hole (27) and fuel is thereby sucked up from the channel above the main jet (24) through a calibrated hole (25) and the idling jet (23) to the idling channel which terminates in the carburetor throat with one larger (27) and two smaller holes (29). Air is supplied through a hole (21) under the choke and through an air jet (22) above the idling jet.

The fuel/air mixture is set by means of an adjuster screw (28) with which the flow area of the hole (27) for the mixture is varied. Since a certain amount of air passes through the throttle, the fuel/air mixture passing into the engine while idling is richer if the screw is screwed out and leaner when it is screwed in.

The two small holes (29) just above the throttle supply fuel mixed with air when the throttle is open slightly, these holes then co-operating with the variable. This ensures smooth transition.

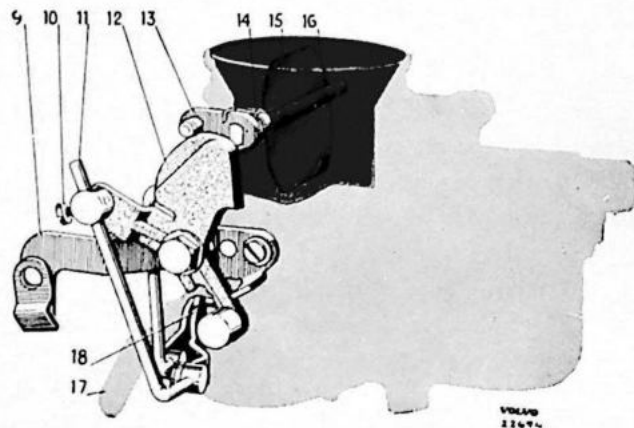


Fig. 11. Choke device and rapid idling.

- | | |
|---------------------------------|----------------------------|
| 9. Control attachment | 14. Spring |
| 10. Rapid idling adjuster screw | 15. Choke flap |
| 11. Link for rapid idling | 16. Spindle |
| 12. Lever for choke flap | 17. Lever for throttle |
| 13. Lever on choke spindle | 18. Lever for rapid idling |

4. Main and compensating jets.

Economiser valve

A great deal of the fuel for the engine when it is under loading and at high speed passes through the main jet (36, Fig. 13).

The main jet alone, however, cannot supply sufficiently accurately calibrated amounts of fuel under all conditions of operation and is therefore combined with a compensating jet (37) which works together with the main jet.

Both the jets are fitted in an emulsion block which terminates in a beak in the carburetor venturi. When it passes through the emulsion block, the fuel is mixed up with a certain amount of air, this making it easier for it to mix with the large amount of air passing in to the engine through the carburetor venturi. The amount of air being supplied to the emulsion block passes through a hole above the main jet space and through channels (30) where the amount of air supplied is varied with the help of the economiser valve.

The space above the compensating jet forms a reservoir for fuel. High speed means a large rate of flow. The fuel then passes more quickly through the hole in the side to the main jet channel whereby the level sinks down to the hole and increased air flow results.

The air channels (30) supply air to the three holes (34) in the side towards the space above the

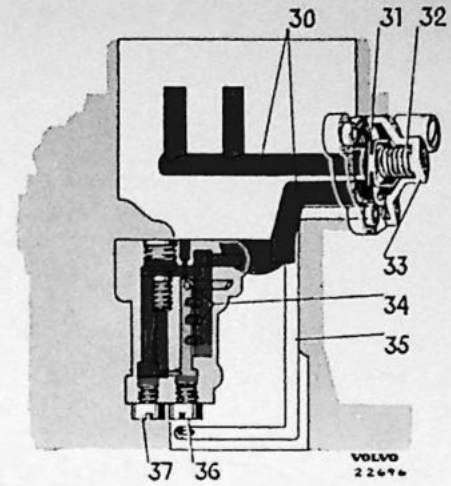


Fig. 13. Jets and economiser valve.

- | | |
|---|---------------------------------|
| 30. Air channels | 34. Holes for supplementary air |
| 31. Diaphragm with valve disc and gaskets | 35. Vacuum channel |
| 32. Spring | 36. Main jet |
| 33. Casing for economiser | 37. Compensating jet valve |

main jet. When the fuel level in this space goes down, more air is supplied and this is mixed with the fuel.

With the help of the economiser valve, the fuel/air mixture receives an extra supplement of air when the degree of vacuum in the carburetor venturi is high. A valve disc is attached to a diaphragm (31), and pressed against its seat by means of a spring (32). This means that the supply of air passes only through the upper small hole at the diaphragm (31).

Behind the diaphragm there is a channel (35) in connection with the lower part of the carburetor venturi. When the degree of vacuum in the venturi increases, for example when cruising without any great loading on the engine, the valve is lifted from its seat and air streams into the emulsion block also through the centre hole at the valve disc.

If the degree of loading should increase, for example during acceleration, the degree of vacuum decreases and the spring presses the disc back onto its seat, whereby the fuel/air mixture will again become richer.

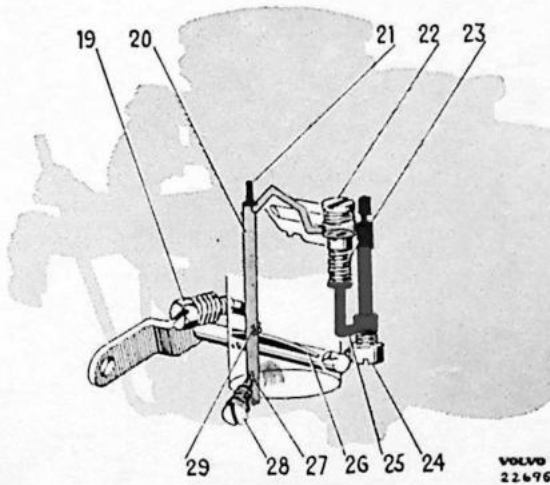


Fig. 12. Idling.

- | | |
|---------------------------|--------------------------------|
| 19. Idling adjuster screw | 25. Fuel hole |
| 20. Channel | 26. Throttle |
| 21. Air hole | 27. Hole (variable flow) |
| 22. Air jet for idling | 28. Idling fuel adjuster screw |
| 23. Idling jet | 29. Transition holes |
| 24. Main jet | |

5. Acceleration pump

If the throttle is opened suddenly, there is a tendency for the fuel/air mixture to be too lean, due to the fact that air moves more quickly than fuel and thus reaches the engine more rapidly.

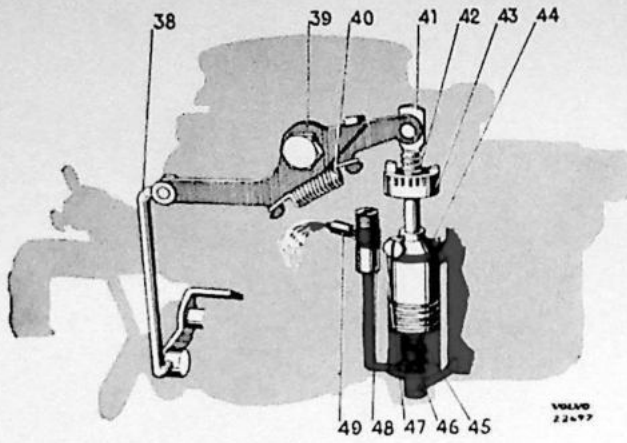


Fig. 14. Acceleration pump.

- | | |
|---------------------------------------|----------------------|
| 38. Link rod | 44. Plunger |
| 39. Jointed lever | 45. Return spring |
| 40. Spring | 46. Inlet valve |
| 41. Plunger rod | 47. Check screw |
| 42. Spring | 48. Outlet valve |
| 43. Washer for pump stroke adjustment | 49. Acceleration jet |

In order to compensate for this sudden leanness, a certain amount of fuel is then sprayed in with the help of the acceleration pump directly into the carburetor venturi.

The pump plunger (44, Fig. 14), is located in a barrel placed beside the float bowl and this plunger is influenced by a jointed lever being depressed. The stroke of the pump plunger can thus easily be varied by turning a washer fitted with a cam (43), whereby the forward part of the lever is limited by a stop, higher or lower depending on the position of the washer. The final part of the rear lever movement is absorbed by the spring (40) at the joint.

At the inlet at the bottom of the pump barrel there is an inlet valve (46) and at the outlet, behind the acceleration jet, there is an outlet valve (48). This outlet valve is fitted with a ball which, when the pump operates, lifts and closes the air hole above whereby fuel is sprayed in through the acceleration jet (49). During normal running the ball closes the connection to the float bowl and instead allows air to pass from the air hole to the acceleration jet. This prevents fuel from passing through this jet when the pump is in its resting position.

Air cleaner

The air cleaner (Fig. 15 or 48 in the illustration at the end of this book) is located above the

engine and functions both as a cleaner for the air being drawn in and as an intake silencer.

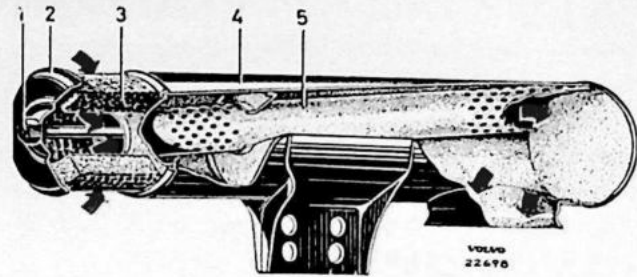


Fig. 15. Air cleaner.

- | | | |
|----------|----------------|--------------------|
| 1. Nut | 3. Wire filter | 5. Intake silencer |
| 2. Cover | 4. Housing | |

Fuel pump

The engine is fitted with a diaphragm type fuel pump, the design of which is shown in Fig. 16. The fuel pump feeds the fuel from the fuel tank to the carburetor and is driven by a cam on the camshaft. The pump is fitted with an idling device whereby the pumping effect ceases when the needle valve in the carburetor float bowl is closed. The pump is balanced for a pressure not exceeding 0.25 kg/cm² (3.5 lb./sq. in.).

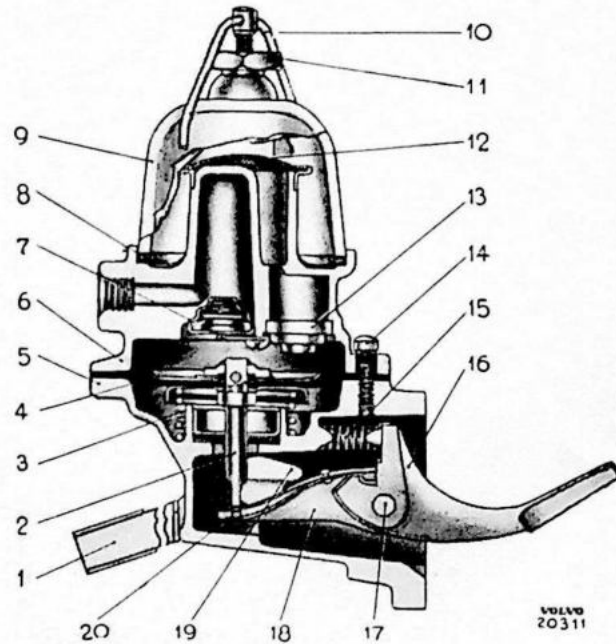


Fig. 16. Fuel pump.

- | | | |
|------------------|-------------------|-----------------|
| 1. Lever | 8. Gasket | 15. Spring |
| 2. Diaphragm rod | 9. Sediment bowl | 16. Rocker |
| 3. Spring | 10. Bowl retainer | 17. Pin |
| 4. Diaphragm | 11. Nut | 18. Link |
| 5. Lower section | 12. Strainer | 19. Lever |
| 6. Upper section | 13. Inlet valve | 20. Lock spring |
| 7. Outlet valve | 14. Screw | |

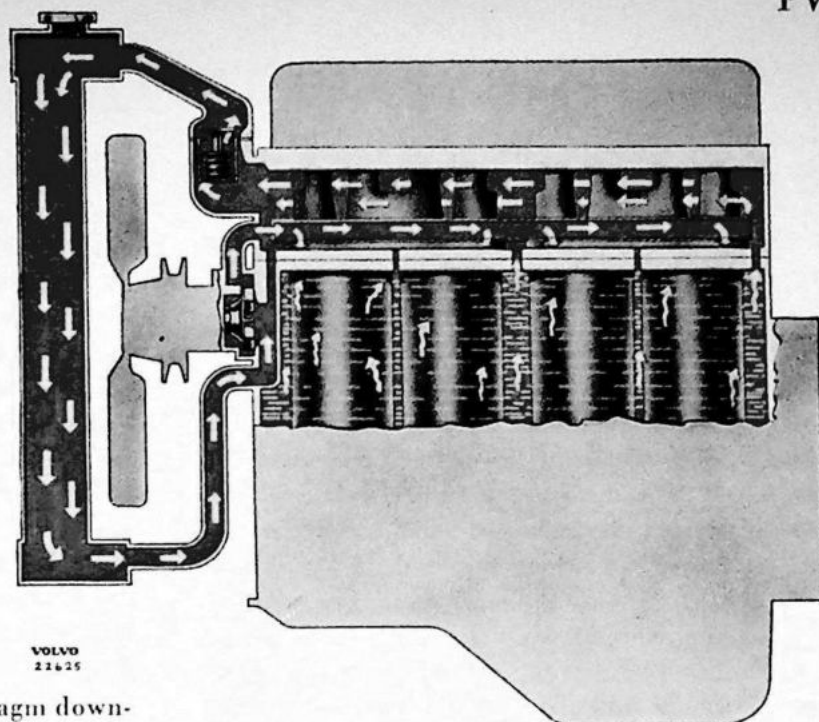


Fig. 17. Cooling system.

When the pull rod draws the diaphragm downwards, fuel is sucked from the tank through the sediment bowl (9), the strainer (12) and the inlet valve (13) to the pump chamber. When the cam has reached its highest point and turns, the lever is returned by a spring (3). The diaphragm is thereby pressed upwards by the thrust spring which is compressed during the suction stroke and fuel is thus forced through the outlet valve (7) to the carburetor. When the carburetor float bowl is full of fuel, the needle valve closes and back pressure occurs in the pump chamber. The diaphragm then stops in its lower position and the spring cannot press upwards again before further fuel has been consumed.

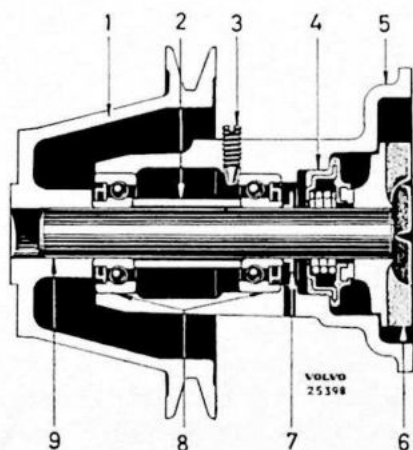


Fig. 18. Water pump.

- | | | | | | | | | |
|---|-----------|---------------|---------|------------|-------------|-----------------|-----------------|----------|
| 1. Pulley (level with shaft on early production units. Various fans used during early and late production). | 2. Spacer | 3. Lock screw | 4. Seal | 5. Housing | 6. Impeller | 7. Slinger ring | 8. Ball bearing | 9. Shaft |
|---|-----------|---------------|---------|------------|-------------|-----------------|-----------------|----------|

The fuel pump is fitted with an external hand primer lever (1) for manual pumping.

Cooling system

In order to ensure effective cooling water circulation, the cooling system includes an impeller type pump which is driven from a pulley on the front end of the crankshaft. This pump sucks up coolant from the lower part of the radiator and forces it into the distribution pipe in the cylinder head. From here the water circulates through the cylinder head and cylinder block and flows down to the lower part of the radiator. The fan is fitted on the forward end of the pump shaft. It produces an intensive flow of air through the radiator which is located in front of the engine.

In order to attain normal running temperature as soon as possible after a cold start, the cooling system includes a thermostat located in a housing between the engine and the radiator. This thermostat prevents the water from passing out into the radiator and being cooled during the warming-up period. Instead circulation takes place only within the engine itself through a hole in the cylinder head to the pump inlet channel. When the cooling water has reached a temperature corresponding to the opening temperature of the thermostat, it starts to open. The thermostat is balanced, this meaning that it does not open under the influence of the cooling water pump pressure.

REPAIR INSTRUCTIONS

Work that can be carried out without removing the engine from the car

Compression test

The purpose of the compression test is to check the cylinders for tightness and this test is done with a compression tester graduated in kg/cm^2 (kilograms per square centimetre) or lb./sq. in. (pounds per square inch). Before the test is carried out, the engine should be run until it reaches its normal operating temperature, the air cleaner should be cleaned, all spark plugs removed and the throttle fully opened. Also check that the choke is fully opened. The battery must be well charged to ensure that the starter motor can turn the engine over with sufficient speed during the test.

The cylinders are checked one at a time by placing the compression tester in the spark plug hole and holding it firmly in position while the engine is turned over with the starter motor until the highest reading is obtained on the tester, (Fig. 19). The readings obtained on each cylinder should be noted unless the compression tester is

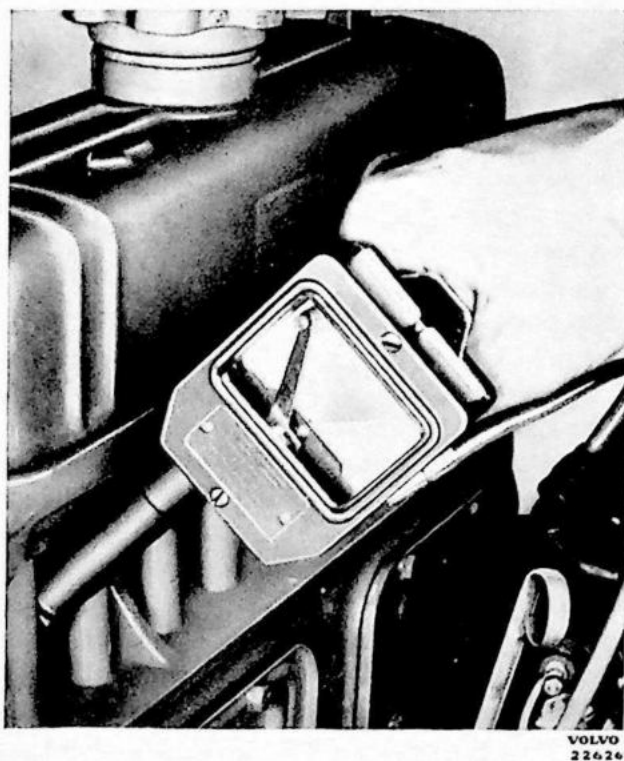


Fig. 19. Measuring compression.

of the self-registering type. Normally the compression pressure should be $9.5\text{--}10.5 \text{ kg}/\text{cm}^2$ ($135\text{--}150 \text{ lb./sq. in.}$) at 200 r.p.m. Deviations of up to 10 % from this range are permissible. If the values obtained are low, a small amount (5 c.c) of thick oil should be introduced into each cylinder. Make sure that no oil gets onto the valve discs. Repeat the test and note the reading for each cylinder.

By comparing the values of compression pressure in the cylinders obtained with and without oil, some idea can be obtained of the condition of the piston rings and valves. If the pressure is higher after the oil was introduced, this implies that the piston rings are not sealing tightly. If the compression pressure is low in one or more cylinders both with and without oil, then the valves are probably not sealing tightly. If two adjacent cylinders have a very low compression pressure, check to ensure that there is no leak in the cylinder head gasket between these two cylinders.

Tuning up the engine

The purpose behind the tuning up of an engine is to ensure that it starts more easily, runs more easily, develops more output and has minimal fuel consumption. Engines should be tuned up regularly at intervals of 10,000—20,000 km (6,000—12,000 miles).

The best way to tune up an engine is to carry out the operations in the following order:

1. Run the engine warm and check the dwell angle (contact breaker gap) and the ignition timing. Adjust to the correct values. Replace burned contact breakers. Examine the distributor cap for cracks and scrape off all oxide contacts. Check the ignition cables to see that they are free from oxide.
2. Examine the state of charge of the battery. If the specific gravity of the battery electrolyte is lower than 1.230, the battery must be charged. If one of the individual cells has a low specific gravity, find out the reason why. Examine all cables. They should be thoroughly tightened onto their terminals. Replace broken or poorly insulated cables.
3. Remove all the spark plugs for cleaning, adjusting and testing or replace them with

new plugs. Clean the air cleaner and sediment bowl. Measure the compression on all the cylinders, see above.

4. Adjust the valve clearances to the stipulated values.
5. Clean the carburetor and check that the settings are correct, see under the heading "Carburetor". Check that there are no air leaks at the carburetor or on the induction manifold. Tighten nuts. Replace gaskets and washers if necessary.

Engine decarbonizing and valve grinding

Disassembly procedure

The engine should be decarbonized and the valves ground after every 30,000—40,000 km (20,000—25,000 miles). On engines used for hard driving, the intervals between decarbonizing can be longer.

1. Drain off the cooling water. Remove the air cleaner.
2. Remove the rocker arm cover with gasket.
3. Loosen and lift off the rocker arm mechanism and push rods.
4. Remove the upper radiator hose and remove the sensitive head for the temperature gauge.
5. Loosen all the controls at the carburetor.
6. Lift off the ignition cables from the spark plugs.
7. Disconnect the exhaust pipe at the exhaust manifold.
8. Remove all the cylinder head nuts. Lift off the cylinder head.
9. Clean the piston crowns and blow off carbon deposits with compressed air. Do not use abrasive cloth since the abrasive material can easily come between the pistons and the cylinder walls. Clean the upper surface of the block with a soft steel brush and compressed air. Cover the openings to the valve lifters.
10. Clean the cylinder head.

Also follow the instructions given under the heading "Valves and valve mechanism" on page 24.

Assembly

Make sure that the sealing surfaces on the cylinder block and the cylinder head are absolut-

ely clean and perfectly flat. Check with a steel rule. Place the gasket on the block. Make sure that the oil channel for the rocker arm mechanism is not blocked. Grease the cylinder walls with engine oil. Fit the cylinder head. Tighten the nuts. See "Tightening torque" in the specifications. Make a preliminary adjustment of the valves before screwing in the spark plugs. Fit the other components and fill the cooling system. Start the engine and let it run for at least 15 minutes. Then retighten the cylinder head nuts, see Fig. 84, and carry out final adjustment of the valve clearances.

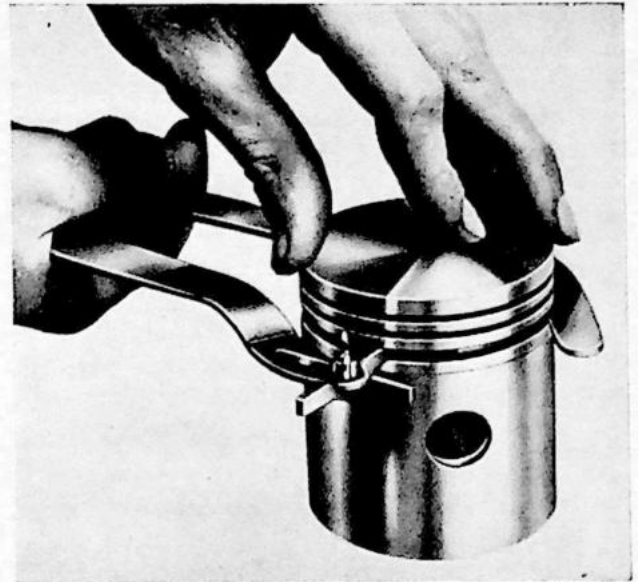


Fig. 20. Cleaning the piston ring grooves.

	Inlet	Exhaust
Valve clearance	0.40 mm (0.016")	0.45 mm (0.018")

The valves should be finally adjusted while the engine is idling. Fit the rocker arm cover with its gasket. Make sure that the gasket is turned the right way. Check and if necessary adjust the ignition timing. Adjust the engine idling speed.

After running for some miles, retighten the cylinder head nuts, see Fig. 84 and then adjust the valve clearances.

Changing the piston rings

1. Follow instructions 1—9 under the heading "Engine decarbonizing and regrinding".
2. Jack up the front end of the car onto supports about 20 cm (8") above the floor. Drain off the engine oil. Remove the oil pan

in accordance with the instructions given under the heading "Removing and fitting the oil pan" on page 13.

3. Check the connecting rod markings. (They should be marked 1—4 on the side away from the camshaft).
4. Scrape away the ridge in the upper part of the cylinders.
5. Remove the connecting rods. Push them upwards together with the pistons through the cylinder bores. Place all bearing shells, caps and nuts in position on the connecting rods.
6. Remove all the piston rings. Clean the pistons and connecting rods. (Note: do not clean the pistons and bearing shells in a degreasing tank). Clean the piston ring grooves and the drain holes in the bottoms of the grooves. Check that the oil channels in the crankshaft are not blocked.
7. Inspect piston pin clearance. If clearance is excessive, new bushings and oversize piston pins must be fitted. Follow the instructions given under the heading "Pistons, piston rings and piston pins", see page 20.
8. Check that the piston rings have the correct clearances in the cylinders and in the piston ring grooves. Follow the instructions given under the heading "Pistons, piston rings and piston pins".
9. Check and straighten the connecting rods if necessary. See page 22.
10. When fitting the pistons make sure that the piston ring gaps are not located directly above each other or opposite the piston pin holes. Make sure that the cylinder walls and connecting rod bearing journals are clean and dry.
Lubricate the pistons, cylinder bores and the connecting rod bearing journals.
Check the markings on the piston crowns, so that the pistons are installed correctly, see page 20. Use tool SVO 2278.
11. Fit the connecting rods and pistons. The connecting rod bolts should be replaced with new bolts each time the engine is reconditioned. It is not necessary to use lock washers.
12. Bolt the connecting rods onto the crankshaft. Make sure that they are tightened very carefully to the exact torque, this being shown in the specifications.
13. Fit the cylinder head and rocker arm mechanism. Roughly adjust the valve clearances.
14. Fit the oil pan. Fill the engine with oil and cooling water.
15. Run the engine warm until it has reached its normal running temperature.
16. Tighten the cylinder head nuts, adjust the valve clearances, check ignition timing and the carburetor. See "Running in the engine" on page 39.

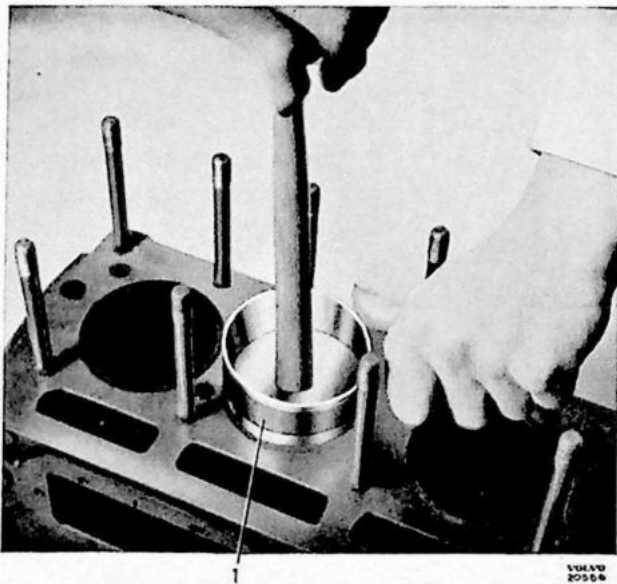


Fig. 21. Fitting a piston.
1. SVO 2278

Replacing main bearing shells

The main bearing shells can be replaced without removing the engine from the car. The oil pan must be removed. See under the heading "Removing and fitting the oil pan".

Remove the nuts from the main bearing bolts and then remove the caps and the lower halves of the main bearings. The upper bearing shells are removed by inserting a pin (1, Fig. 22) in the oil channel and then turning the crankshaft in its normal direction of rotation. The bearing shells (2) then move round with the crankshaft and can be taken out. Check the bearing journals with the help of an indicator, the point of which is touching the journal and then rotate the shaft. If out-of-roundness is more than 0.05 mm (0.002") then the crankshaft must be removed and reground.

Fit new bearing shells. Make sure that the keys come correctly in their grooves.

See the specifications for sizes.

Fit the bearing caps and tighten the nuts to the torque shown in the table on page 54. Lock washers were only used on early production units and are no longer necessary. Check the tightening torque carefully with a torque wrench. Fit the oil pan and fill up with oil.

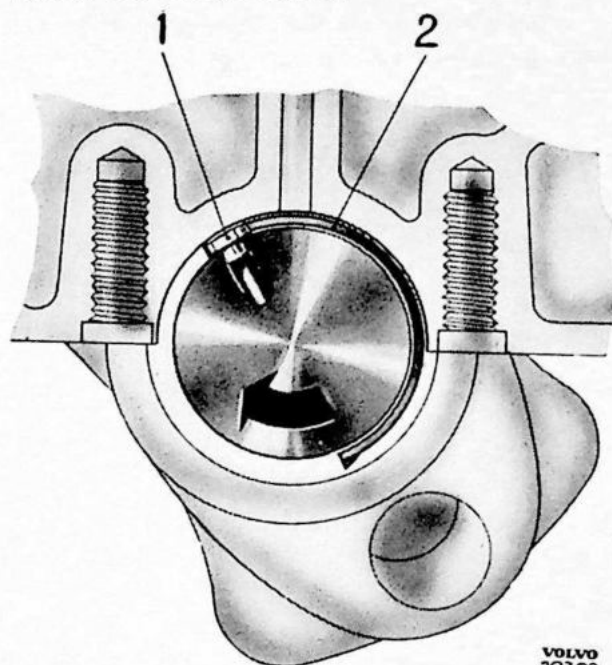


Fig. 22. Removing a main bearing shell.

1. Pin 2. Bearing shell

Replacing connecting rod bearing shells

The connecting rod bearing shells can be replaced without taking the engine out of the car. Remove the oil pan in accordance with the instructions given below. Remove the nuts on the connecting rod bearings after the bearing in question has been turned downwards. The connecting rod cap can then be removed as well as the lower bearing half. The connecting rod can then be pushed upward slightly and the upper bearing half removed.

Wipe the crank clean (use a linen cloth) and use a micrometer to measure the size and the out-of-roundness. If the out-of-roundness is more than 0.07 mm (0.0028"), the crankshaft must be removed and ground since this can be the reason why the bearing has failed. As far as sizes are concerned see under the heading "Main and connecting rod bearings".

Lubricate and fit the new bearing shells. Use new bearing bolts. Tighten the nuts to the torque shown in the table on page 54. Lock washers were only used on early production units and are no longer necessary but the torque must be carefully checked with a torque wrench. Fit the oil pan and fill with oil.

Removing and fitting the oil pan

The oil pan can be removed without taking the engine out of the car as follows:

1. Drain off the oil from the engine.
2. Remove the cover plates from the sides of the engine.
3. Remove the cover under the flywheel.
4. Remove the nuts on the forward engine mountings.
5. Lift up the engine with a jack located under the forward end of the engine (Fig. 23).
6. Slide in the spacers SVO 4124 under the engine mountings and lower the jack.
7. Remove the bolts round the oil pan and pull it out downwards and backwards.
8. Assemble in the reverse order. Always fit a new cork gasket if the old one appears to be damaged or hard.

Replacing the camshaft and/or camshaft gear

1. Drain off the cooling water and detach the radiator blind cable.
2. Remove the radiator and radiator grille.
3. Remove the fan belt and pull the pulley off the crankshaft. Use puller SVO 2279.

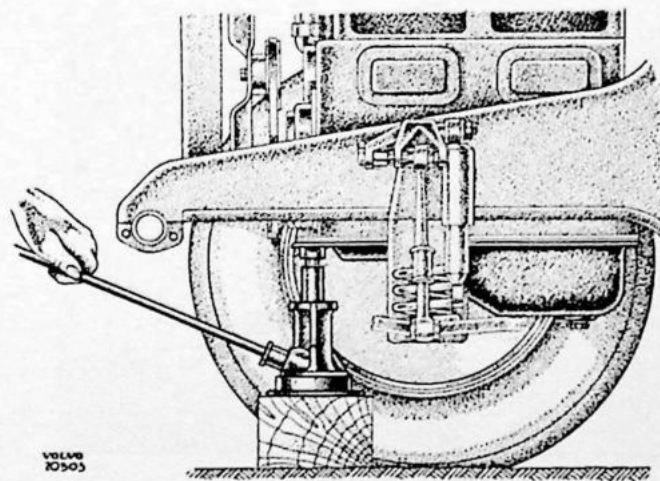


Fig. 23. Jacking up the front end of the engine.

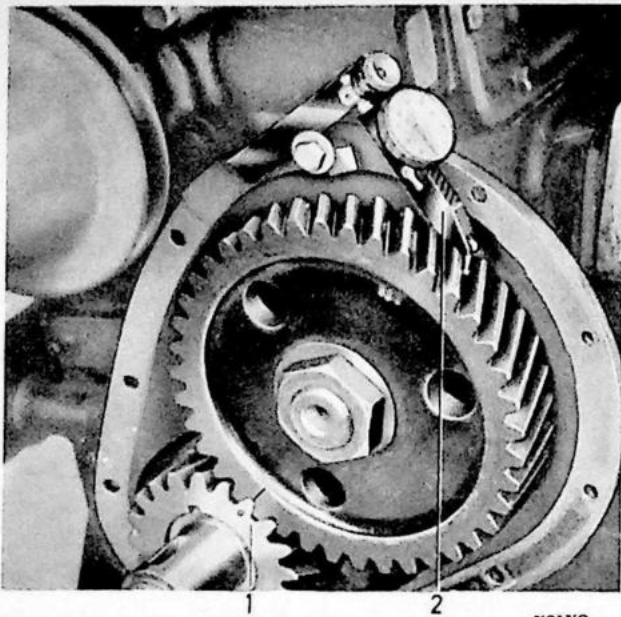


Fig. 24. Measuring backlash.
1. Setting marks 2. Indicator

4. Remove the timing gear casing. Check the gear markings and backlash, see Fig. 24. See the specifications for the values concerned.

If it is only necessary to replace the camshaft gear, it is not necessary to lift out the camshaft. Loosen the lock washers and nuts and then pull off the gear with tool SVO 2250. Fit the new gear by using tool SVO 1356, see Fig. 25.

5. If the camshaft is to be replaced, remove the radiator grille, rocker arms, push rods and fuel pump. Loosen the side covers and remove the valve lifters. This work is facilitated if the distributor is also removed.

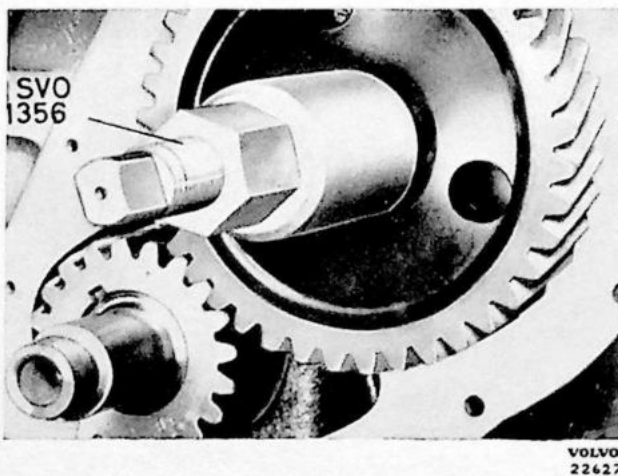


Fig. 25. Fitting the camshaft gear.

6. The camshaft can now be pulled out forwards after the thrust flange has been removed.
7. Fit in the reverse order. Make sure that the washer at the back of the block is not driven out. Make sure that the gears are adjusted correctly and that the flat side of the camshaft nut is turned to face the gear. Centre the timing gear casing by using tool SVO 1427. Check the cork gasket under the casing.
8. Adjust the valve clearances and ignition timing.

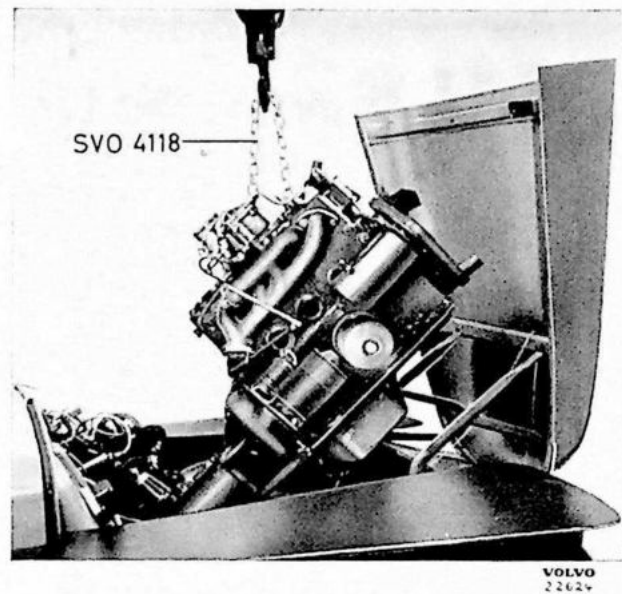


Fig. 26. Removing the engine.

Removing the engine from the car

1. Drain off the cooling water, engine oil and transmission oil. Remove the battery (if necessary), as well as the radiator and air cleaner.
2. Disconnect all electrical connections, disconnect the fuel pipe at the fuel pump, the oil pipes, the pipe to the temperature gauge, the hand throttle, accelerator and choke controls. Disconnect the exhaust pipe and the manifold.
3. Remove the nuts from the front engine mountings, remove the gearshift lever.
4. Jack up the car onto supports about 20 cm (8") over the floor.

5. Remove the cover plates from both sides under the engine. Disconnect the speedometer drive cable at the transmission and disconnect remaining controls.
6. Place a jack under the transmission and remove the propeller shaft at the flange on the transmission drive shaft. Remove the support member under the transmission.
7. Place the lifting chain SVO 4118 in position and lift out the engine. Lifting is facilitated if the front end of the engine is lifted upwards.

Disassembling the engine

When the engine and transmission have been lifted out of the car, they should be thoroughly washed externally before being disassembled.

Kerosene or white spirit can be used for this purpose (less inflammable than gasoline), after which the engine should be rinsed with water, preferably warm, and then blown dry with compressed air. Only use small quantities of the washing fluid at a time.

After washing, remove the transmission from the engine.

The engine is disassembled in the following order:

1. Remove the dipstick, crankcase breather, carburetor, fuel pump, distributor and accelerator controls.
2. Place the engine in a suitable stand. Check that all the oil has been drained off.
3. Remove the clutch. The clutch together with the flywheel crankshaft are balanced as one unit and marked with paint. Mark the parts with a punch so that they can later be re-assembled in the correct position.
4. Remove the oil cleaner, starter motor, generator and spark plugs.
5. Disconnect the inlet and exhaust manifolds, thermostat housing, water pump and water inlet elbow pipe.
6. Loosen the rocker arm shaft and lift up the push rods.
7. Remove the cylinder head. Remove the side covers and lift up the valve lifters.
8. Pull the pulley off the crankshaft. Use SVO 2279.
9. Loosen the timing gear casing and remove it.

10. Check that the markings on the timing gears agree. Then pull off the camshaft gear with tool SVO 2250.
11. Pull the gear off the crankshaft with SVO 1428.
12. Turn the engine upside down and remove the oil pan.
13. Remove the lubricating oil pump with strainer and pressure pipe. Remove the relief valve plug and pull out the plunger with tool SVO 2079.
Remove the rear sealing flange for the crankshaft.
14. Remove the thrust flange for the camshaft and pull out the camshaft.
15. Loosen the caps for the connecting rod bearings and push out the pistons with connecting rods through the cylinder bores. Replace the caps and nuts on the respective connecting rods. Check the markings. The connecting rods should be marked 1—4 and the marking should face away from the camshaft side.
16. Remove the seal plate for the timing gear casing.
17. Loosen the main bearing caps and lift up the crankshaft with the flywheel and put in a protective place. Fit the caps on the block in the right order. The caps are marked with an arrow pointing forwards.
18. Remove the flywheel housing.
19. Remove the pistons from the connecting rods. Use tool SVO 1340, see Fig. 30.

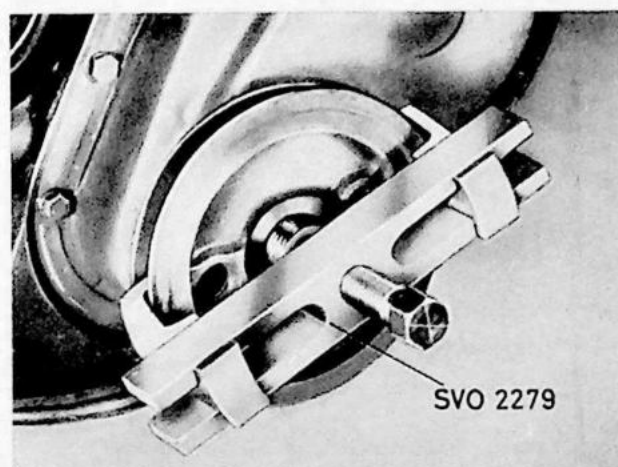


Fig. 27. Removing the pulley.

VOLVO
20335



Fig. 28. Removing the camshaft gear.

Cleaning the engine parts

After the engine has been disassembled scrape off carbon deposits, oil deposits and bits of old gaskets and then wash all parts thoroughly. Use kerosene or white spirit. Make a habit of only using a small amount of washing agent at a time. First wash the pistons, then the connecting rods, crankshaft and camshaft.

If a special degreasing tank is available heated either electrically or with steam for use with lye, the engine parts can be conveniently cleaned in this.

Care must be taken when washing parts made of light alloy. These should not be allowed to remain in the lye more than half an hour. Pistons may not be placed in normal lye solution. After cleaning all parts should be carefully washed, preferably with warm water. Rinse through all oil channels and then blow the parts clean with compressed air. Use an air pistol so that the oil channels and narrow spaces are properly cleaned.

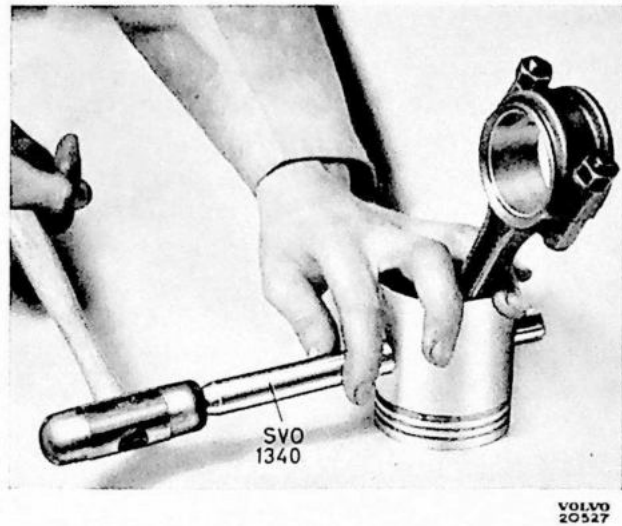


Fig. 30. Removing a piston pin.

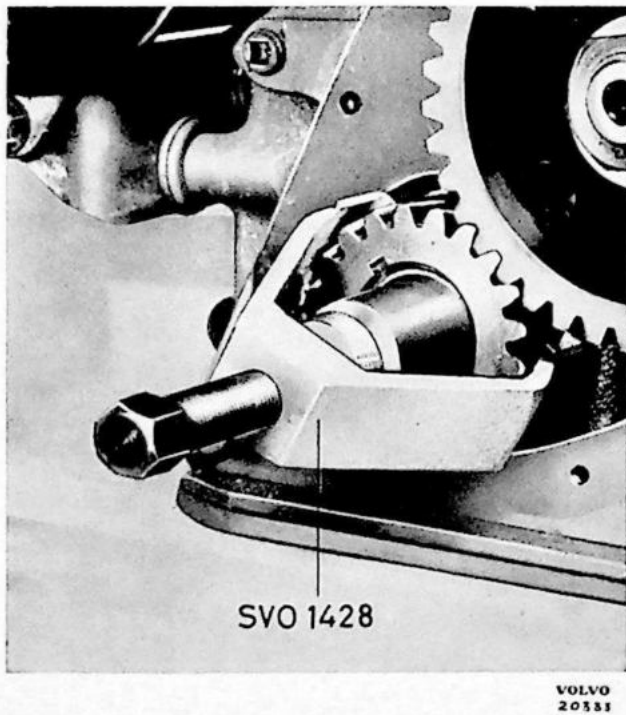


Fig. 29. Removing the crankshaft gear.

Cylinder block Gauging the cylinders

The cylinders become most worn at their upper ends and thus become tapered. They also become out-of-round. In order to obtain a complete impression of the appearance of the cylinder, it must be measured at various points both parallel and at right angles to the engine. The cylinder is measured by using a special cylinder indicator. Fig. 31.

This indicator registers the relative wear in the cylinder walls by comparing the difference between the highest and lowest values obtained. The actual wear of the cylinder where it is a maximum is obtained by zeroing the indicator with the help of a micrometer. A letter is stamped beside each cylinder bore showing the original bore of the cylinder (standard) according to the table below. The micrometer is set to the lower limit in each cylinder bore range.

If the engine has been rebored, remove the soot ridge in the upper end of the cylinder and then zero the gauge against this.

The amount of wear measured determines the remedy to be used. If the engine has abnormally high oil consumption and wear of up to 0.25—0.30 mm (0.010—0.020") or if there are signs of scoring in the cylinder walls, reboring should be carried out.

Class	Cylinder bore
C	79.35—79.36 mm (3.1240—3.1244")
D	79.36—79.37 mm (3.1244—3.1248")
E	79.37—79.38 mm (3.1248—3.1252")

Reboring the cylinders

The boring of cylinders must be carried out in special machines. Since high demands are made concerning precision, this work requires highly skilled and experienced workers. It is exceptionally important to ensure that the cylinder bores are completely circular without taper and at right angles to the crankshaft within very close limits. The cylinder walls must also be machined to the very highest finish in order to shorten running-in time.

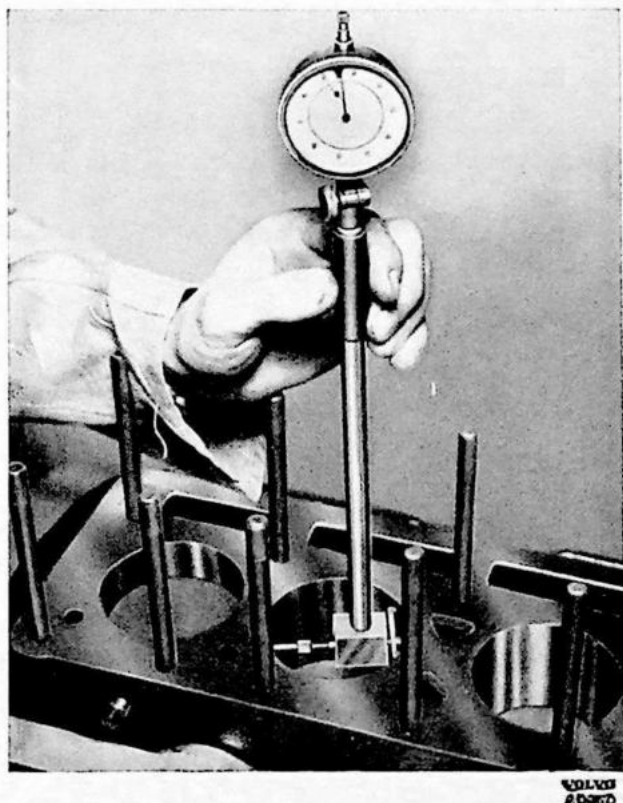


Fig. 31. Gauging a cylinder bore.

The cylinders are first measured in order to determine a suitable oversize, see the specifications on page 48. They are then bored and honed to the exact size. See under the heading "Piston clearance", page 20. Before being fitted in the car, the block should be cleaned, preferably in a degreasing tank, in order to remove any metallic particles.

Cracks

If leakage in the block is suspected, it can be tested with water under pressure. The top of the block is sealed by using the gasket and the cylinder head or by using a plate made of strong material.

The pressure of the water should be about 3 kg/cm² (45 lb./sq. in.).

Cylinder head

Leakage

If cracks in the cylinder head are suspected, the head must also be tested with water under pressure. Use the same plate as was used for testing the block to seal off the water channels. Take out the water pipe, use tool SVO 4120, and in its place bolt on a plate with a connection for a hose.

The pressure of the water should be approximately 3 kg/cm² (45 lb./sq. in.).

Crankshaft

Gauging the crankshaft journals

The crankshaft should be checked for linearity and the journals should be checked for out-of-

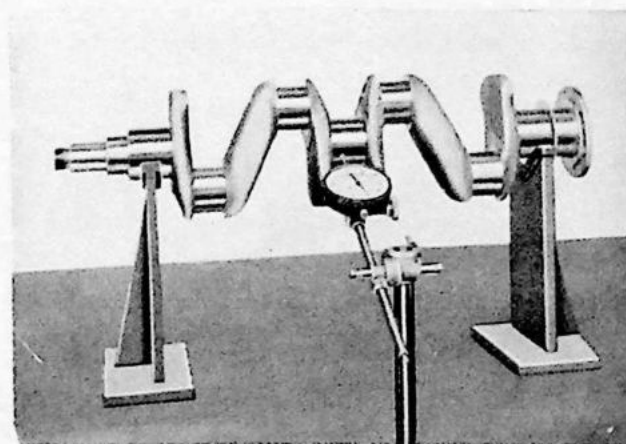


Fig. 32. Gauging the crankshaft.



Fig. 33. Gauging a bearing journal.

roundness, taper and score marks. Place the crankshaft in vee-blocks to check its linearity. Move up a dial indicator against the centre main bearing journal and then rotate the crankshaft, see Fig. 32. The dial indicator registers any eventual distortion of the crankshaft and also shows the out-of-roundness of the journal. A micrometer should be used separately in order to determine the out-of-roundness of the journals. The maximum permissible runout of the centre journal is 0.05 mm (0.0020").

A micrometer is used to check out-of-roundness (see Fig. 33). The maximum permissible out-of-roundness is 0.05 mm (0.0020") on the main bearing journals and 0.07 mm (0.0028") on the connecting rod bearing journals. The largest permissible taper is 0.05 mm (0.002"). A distorted crankshaft can be aligned in a press. Out-of-round or tapered bearing journals should be ground to a suitable undersize, see the dimensions on page 49. Scored bearing journals should also be ground. Grinding should be carried out in a special machine.

Grinding the bearing journals

The minimum and maximum diameters when grinding the crankshaft to undersize are shown in the specifications. The width of the guide bearing, A, Fig. 34, depends on the journal size.

It is exceptionally important to follow the dimensions given in the table since they, together with the corresponding bearing shells, ensure the correct bearing clearance.

After the grinder has been dressed, the journal radii should be 2.75—3.00 mm (0.11—0.12") as shown in Fig. 34.

After grinding the journal should be lapped with fine grinding paste, edges removed from the oil holes and the whole crankshaft should be thoroughly cleaned.

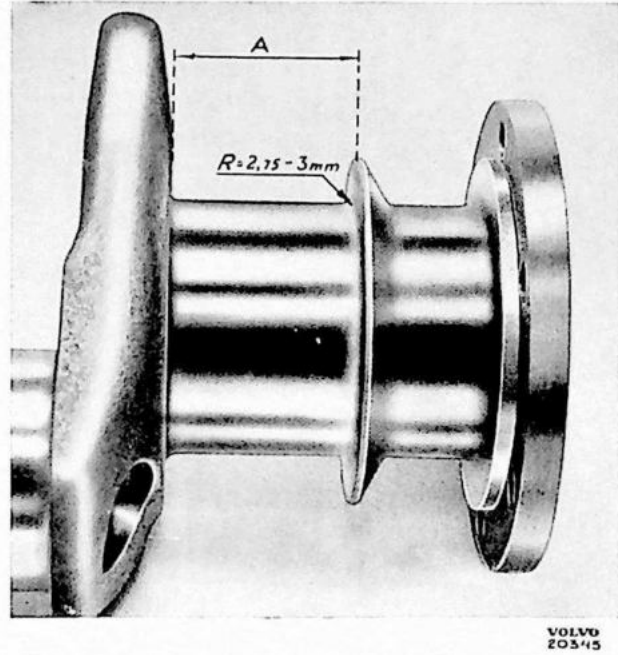


Fig. 34. The guide bearing journal width.

Oil passages

The crankshaft should be cleaned by boiling it in a degreasing tank and then flushing it with water and blowing off with compressed air. The passages should also be cleaned by using a special brush.

Main and connecting rod bearings

Undersizes

Replacement bearing insert shells are available in the following undersizes:

0.010", 0.020", 0.030", 0.040".

All bearings have their respective part numbers stamped on the back. Undersize bearing shells are also stamped with 01, 02, 03 and 04 to designate the respective undersizes. The flange bearing shells have widths with oversizes 0.1, 0.2, 0.3 and 0.4 mm (0.004", 0.008", 0.012" and 0.016").



Fig. 35. Measuring a piston.

VOLVO
20394

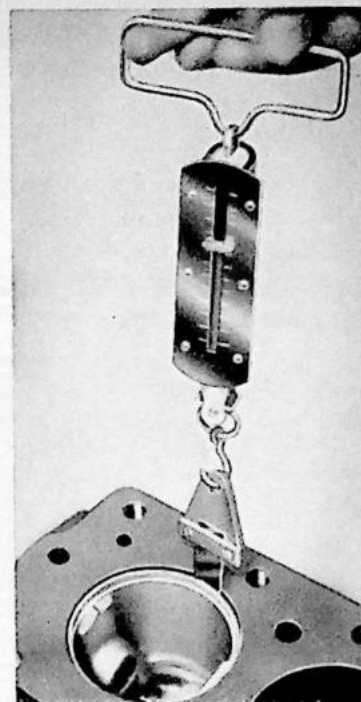


Fig. 36. Checking piston fit.
Pull 2-3 kg (4-7 lb.) spring steel
0.015 mm (0.0018") thick, 1/2" wide.

VOLVO
22705

Fitting the main and connecting rod bearings

Adjustment of bearing clearance may never be carried out by filing the bearing caps. The bearings are of the precision type and may never be filed or scraped. Since they are replaceable, new shells should be fitted if there is any kind of damage or wear. If the bearing journals are damaged or worn out-of-round, they should be ground and undersize bearing shells fitted. Always inspect the oil flow to a damaged bearing.

Oil seals

The rear main bearing is fitted with a felt seal in two parts which is attached to the engine block by means of two sealing flanges.

On the front end of the crankshaft there is a sheet metal oil-slinger clamped between the crankshaft gear washer and the pulley hub. In the timing gear casing there is a felt ring which seals against the pulley hub. Inside both the forward and rear felt seals there is a limited cavity with draining holes at the bottom. Make sure to see that these holes are open since they are designed to lead off oil back to the oil pan. Early production rear seals do not have this cavity.

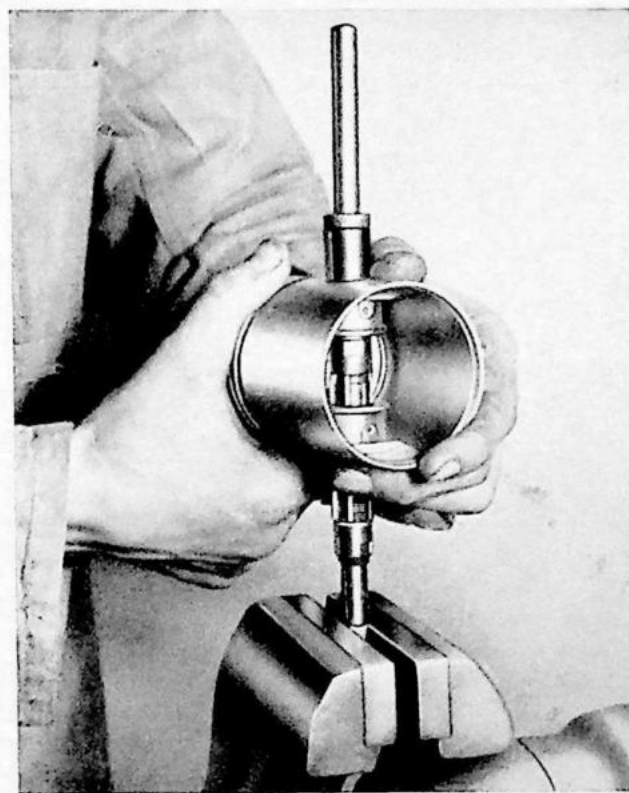


Fig. 37. Reaming a piston.

VOLVO
20351

In order to have the correct alignment between the casing and the crankshaft, an aligning tool SVO 1427, should be used when fitting the timing gear casing. Then fit the pulley.

Pistons, piston rings and piston pins

Gauging pistons

The pistons are measured with a micrometer at right angles to the piston pin on the lower edge of the piston, Fig. 35.

See the specifications for dimensions concerning pistons and cylinder balls.

Piston clearance

The piston should have a certain clearance in the cylinder bore. This clearance is measured with a piece of spring steel 0.045 mm (0.0018") thick and 1/2" wide fitted on a spring balance. The pull required should be 2—3 kg (4—7 lb.).

Measurement should be carried out in the direction of thrust of the piston along the complete length of the cylinder bore and at several diameters in the cylinder. The piston pin should not be fitted while this measurement is being carried out.

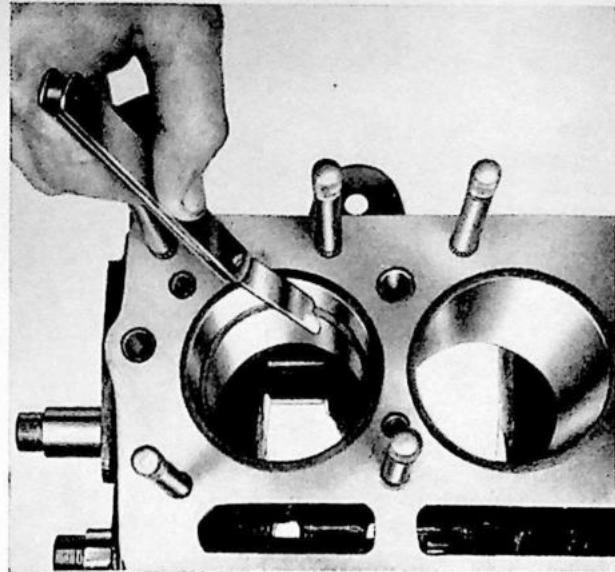
When checking the clearance of a piston in a standard bore cylinder, select the piston which corresponds to the class stamped on each cylinder bore. In cylinder E, for example, a piston of class E should always be fitted.

Note. This only applies to standard cylinder bores.



VOLVO
20347

Fig. 38. Checking piston pin fit.



VOLVO
20357

Fig. 39. Checking piston ring clearance.

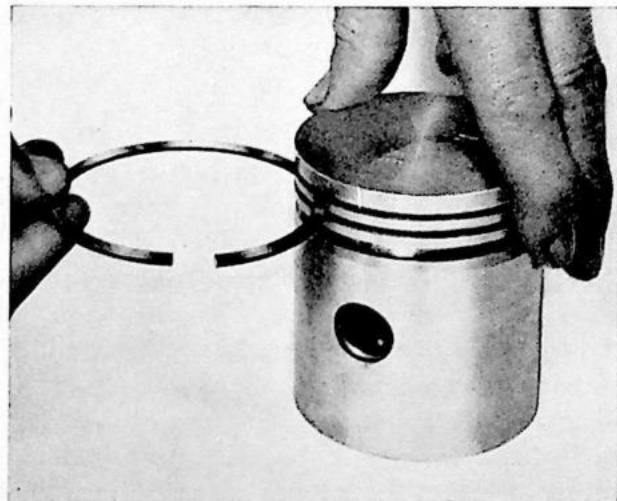
Piston pin clearance

When fitting a piston pin in a piston, use a reamer fitted with a guide, Fig. 37. Reaming should be carried out very carefully and only a slight cut made with each pass. Correct fit is achieved when the piston pin can be pushed through the hole in the piston with thumb pressure (Fig. 38). The piston and piston pin should both be at normal room temperature when this is done.

Piston ring clearance

a) *New or rebored cylinder.*

The gap between the piston ring ends with



VOLVO
20552

Fig. 40. Checking piston ring clearance in groove.

the ring fitted into the cylinder bore, see Fig. 39 should have a certain value. The measurement is 0.25—0.50 mm (0.01"—0.02") and should be checked with a feeler gauge. Adjustment is carried out by using a special file.

The piston rings must not bind anywhere in the groove. Check this by rolling the ring in the groove round the piston, Fig. 40. Also measure clearance at a few places. The correct value for the clearance is 0.068—0.079 mm (0.0027"—0.0031").

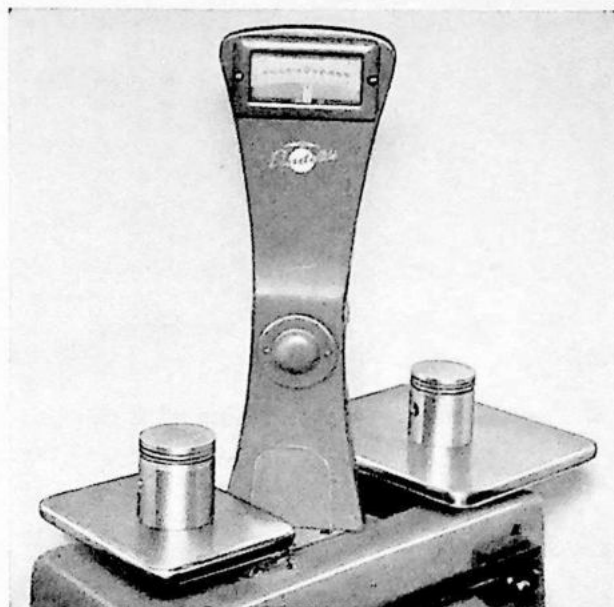
VOLVO
20349

Fig. 41. Weighing pistons.

b) *Worn cylinder bore*

When checking piston ring clearance in a worn bore, the ring gap should always be checked at the bottom dead centre position of the piston since the bore is worn to a taper. If the ring gap is faultily checked in the upper part of the cylinder, the ring ends can contact each other at the bottom dead centre position with subsequent seizing.

If the cylinder ridge is not removed the upper part of the top compression ring must be beveled.

Weighing pistons

It is important that all the pistons in the engine have the same weight within certain specified limits in order to avoid the occurrence of vibrations in the engine. The maximum permissible

weight difference between pistons in the same engine is 10 grams (0.36 oz.).

Assembling the pistons and connecting rods

Before a piston and connecting rod are assembled together, the piston pin clearance in both the piston boss and the connecting rod

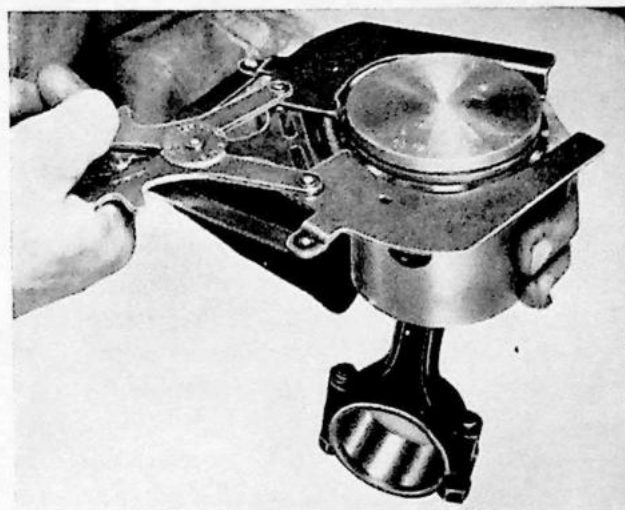
VOLVO
20357

Fig. 42.

bushings must be correct. The connecting rod must also be absolutely straight. The piston rings should not be fitted onto the piston until the

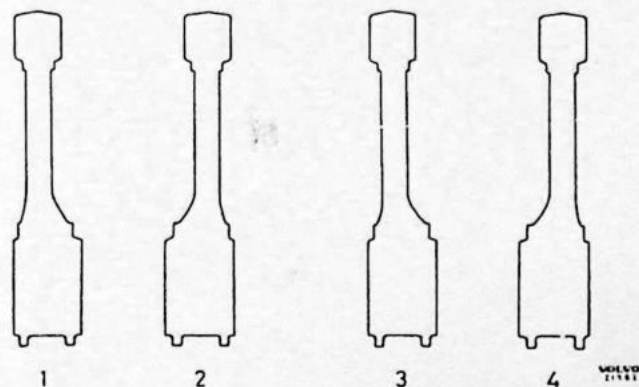
VOLVO
20358

Fig. 43. Connecting rod locations.

piston and rod have been assembled. The compression rings are beveled on the inside edge which should be turned to face upwards. The top compression ring on each piston is chromed. When fitting the piston rings use a special piston ring expander tool (Fig. 42) so as to avoid damage to the piston rings. Lubricate the piston pin and the bushing before assembling. Check that the piston is correctly assembled on the

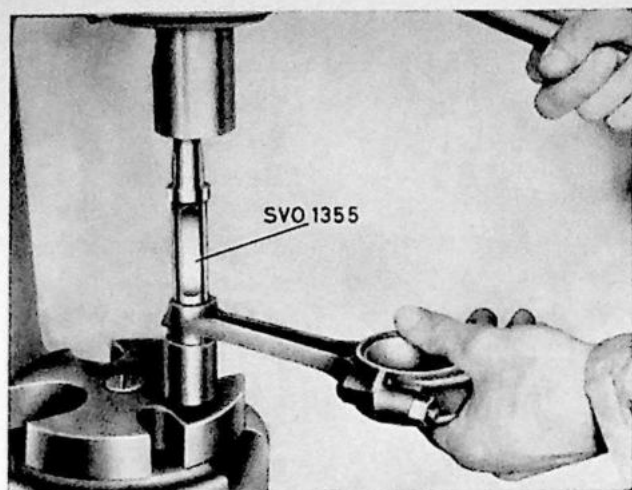
VOLVO
7032V

Fig. 44. Removing a bushing.

connecting rod. Since the piston pin hole in the piston is not exactly central, it is important to ensure that the correct side of the piston faces forward. For this reason the pistons are marked with an arrow showing the front end of the engine. The connecting rods, which are offset in the longitudinal axis of the engine, are fitted in accordance with Fig. 43. Fix the circlips in both sides of the piston.

Connecting rods

Replacement of piston pin bushing

Press out the old bushing by using tool SVO

VOLVO
2035B

Fig. 45. Piston pin fit.

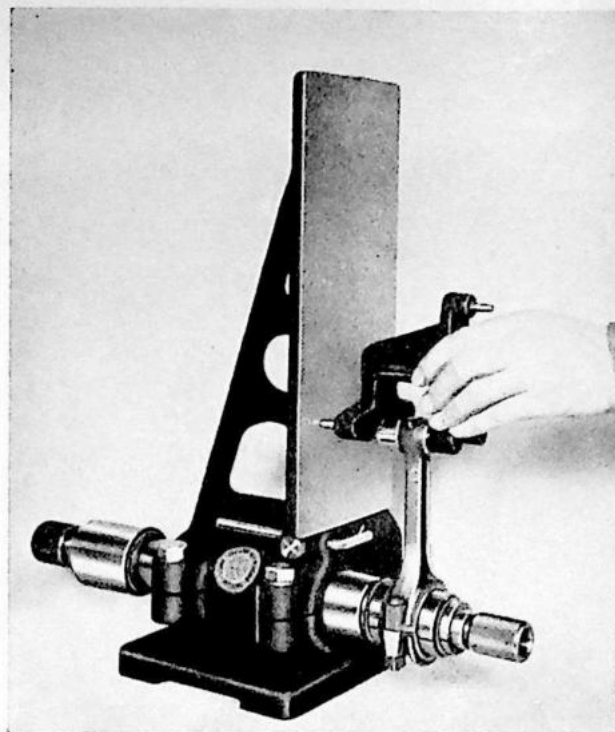
VOLVO
2035V

Fig. 46. Checking a connecting rod.

1355 and press in a new bushing with the same tool. Use a suitable sleeve. The bushing is then reamed to the correct size for the piston pin. Make only light cuts in this work and check repeatedly with the piston pin until it obtains a light thumb fit without noticeable looseness (Fig. 45).

Straightening connecting rods

The connecting rods should always be checked and, if necessary, straightened before being fitted. See Fig. 46 and 47. Alignment should be carried out both with and without the piston fitted. If the piston has been removed from the connecting rod, straighten the connecting rod without the piston and then make a final check with the piston fitted. Deviation should not exceed 0.01 mm (0.0004") measured over a length of 100 mm (4").

When a connecting rod has been straightened with the piston fitted, the piston ring should be removed.

Connecting rods should also be checked for freedom from S-distortion, due attention being paid to the fact that the connecting rods are offset, see Fig. 48.

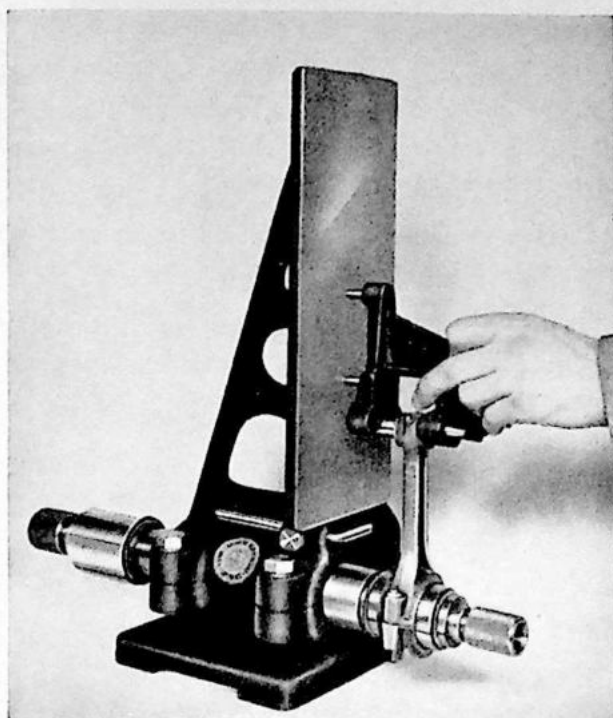


Fig. 47. Checking a connecting rod.

Weight

The connecting rods in any engine should have the same weight within certain limits. By means of a classification system with various letters, A—D, the connecting rods which lie within these limits are marked with the same letter. This letter is stamped into the connecting rod immediately above the bearing cap dividing line.

Only connecting rods marked with the same letter may be fitted in the same engine. Weights concerning a complete connecting rod with the fully machined bushing are shown in the specifications.

Camshaft

The camshaft should be inspected for linearity and for wear on the journals, cams and distributor gear. The camshaft should be straight to within 0.04 mm (0.0016"). A bent camshaft cannot be straightened and a new camshaft should be fitted instead.

The maximum permissible wear on the bearing

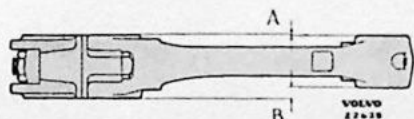


Fig. 48. Connecting rod offset.

Permissible deviation = ± 0.25 mm (± 0.010 ")
 A = 0.85 mm (0.033") B = 5.85 mm (0.230")

journals is 0.075 mm (0.003") if new bearings are fitted.

If the cams, journals or ignition distributor gear are much worn, a new camshaft should be fitted.

Both forged and cast camshafts have been used and a matching oil pump gear must be fitted, i.e. a cast camshaft must have a cast gear fitted and a forged camshaft must have a forged gear fitted. The camshafts can be identified through checking the part number which is stamped on the rear end. The cast gears are phosphated (grey-black).

Camshaft adjustment

The timing gears are marked showing the correct setting. See A, Fig. 49.

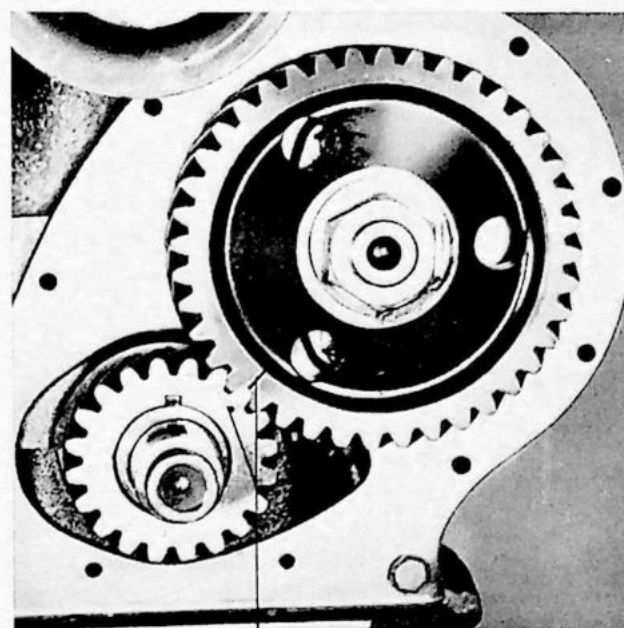


Fig. 49. Timing gear settings.

Replacing camshaft bearings

Camshaft bearings that have worn more than 0.05 mm (0.002") should be replaced by new bearings. If this work is to be done perfectly, an arbor drill is needed. When pressing in new bushings, make sure that the holes in the bushings index correctly with the oil passages in the block.

Replacing the camshaft gear

The camshaft gear should be replaced when the backlash reaches 0.12 mm (0.0047"). This gear can be removed without taking the engine out of the car. See page 13. Fit the new gear with the help of tool SVO 1356. Take care to ensure that the gear is not damaged.

Valves and valve mechanism

In order to obtain maximum output and acceleration as well as the best fuel economy, it is very important to ensure that the valves and valve mechanism are in perfect condition. Great care should be taken in work on these components and the measurement and clearances recommended by Volvo should be carefully followed.

Valves

Valve stems should be perfectly straight and the wear must not exceed 0.02 mm (0.0008") at any point. If the valve disc edge is so worn that it is too thin after grinding in a special machine, then the valve should be rejected.

Valve guides

The clearance between the valve stems and the valve guides should be checked with new valves. Use an exhaust valve to check the exhaust valve guides and an inlet valve to check the inlet valve guides, since the stems do not have the same thickness. The clearance with a new valve may not exceed 0.15 mm (0.006").

Clearance is measured as shown in Fig. 50.

Valve springs

The valve spring must conform to the values shown on page 49. The springs are closely wound at one end and this end should be turned to face the cylinder head when the springs are fitted. Testing is carried out as shown in Fig. 51.

Push rods

The push rods must be perfectly straight. This can be checked by rolling them on a surface plate. If they roll irregularly (jerkily) they are distorted and must be rejected.

Replacing valve guides

Press out the old guides using tool SVO 1459. Use tool SVO 4158 when fitting new guides since this gives the correct fitting depth. See Fig. 52.

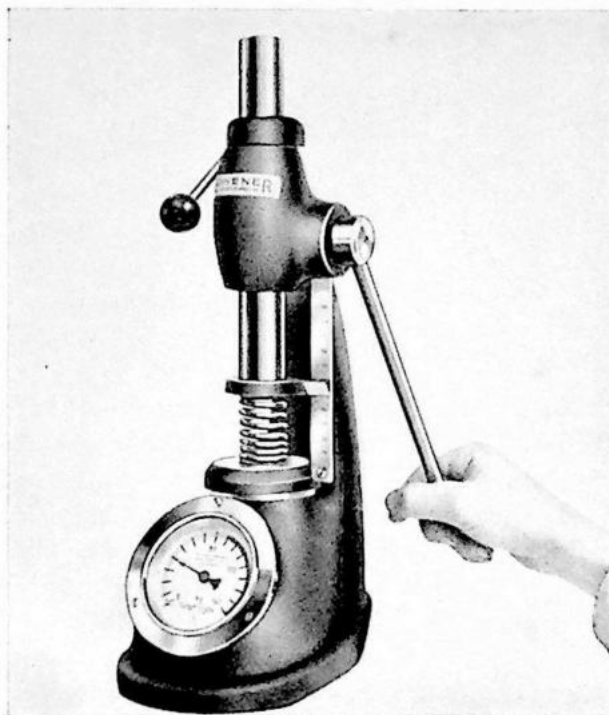


Fig. 51. Testing valve springs.

VOLVO
7051A

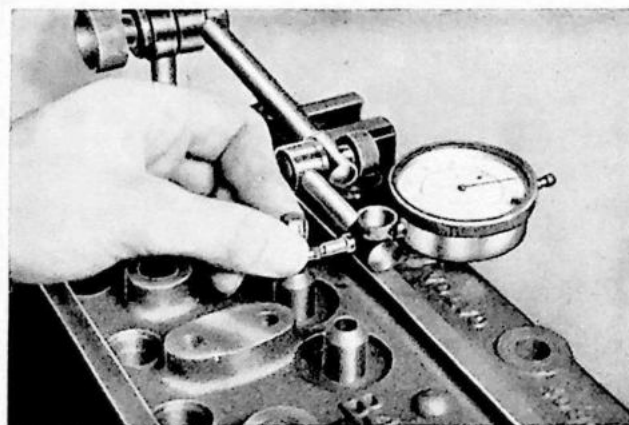


Fig. 50. Measuring valve guide clearance.

VOLVO
2057B

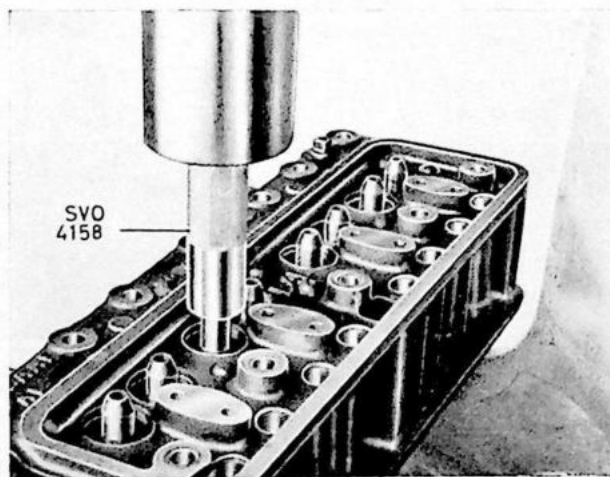


Fig. 52. Fitting valve guides.

VOLVO
22430

When the valve guides have been pressed in, the distance from the upper end of the guide to the upper surface of the cylinder head should be 21 mm (0.83").

New valve guides should be reamed with a special reamer SVO 4128. The same reamer is used for both the inlet and outlet valve guides. Since the inlet valve stems are thicker than the exhaust valve stems, the clearance in the guides will be greater for the exhaust valves.

Valve seat grinding

Before valve seat grinding is carried out the cylinder head should be very carefully cleaned in the combustion chambers and gas ports and, if necessary, new valve guides should be pressed in and reamed.

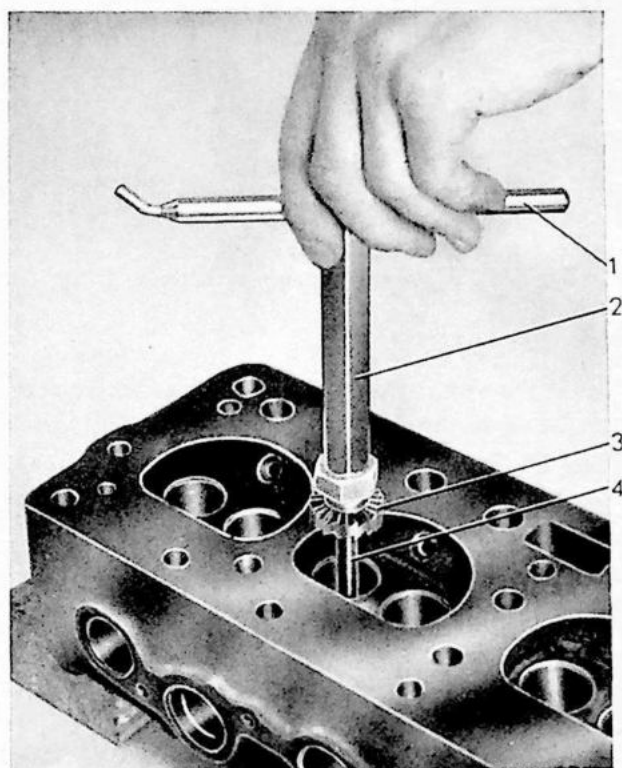


Fig. 53. Refacing valve seats.

- | | |
|------------|------------------|
| 1. Handle | 3. Cutter |
| 2. Spindle | 4. Pilot spindle |

When grinding take care not to remove more material than is absolutely necessary in order to obtain the correct angle form and width of the seat.

Regrinding is carried out either with a tapered cutter, Fig. 53, which is turned by hand, or preferably, electrically driven grinders. Before being used these should be dressed and adjusted

to an angle of 45° . This should be carried out in a special attachment which can be adjusted to the desired angle. When grinding a pilot spindle, which is part of the equipment, is inserted in the valve guide where it is centred and locked by means of an expander. The pilot spindle should be greased with thin oil after which the grinding wheel with retainer is fitted and driven electrically under light pressure. The wheels should only be allowed to rotate for a few seconds at a time after which the machine should be switched off but not lifted out until it has stopped rotating. Continue this procedure until the complete seating surface is perfectly smooth all round. If necessary, the width of the seat face is reduced from above by means of a 20° grinding wheel and inwards by means of a 70° wheel. After grinding is completed, the seat width should be 1.5 mm (0.060"), see measurement A, Fig. 54.

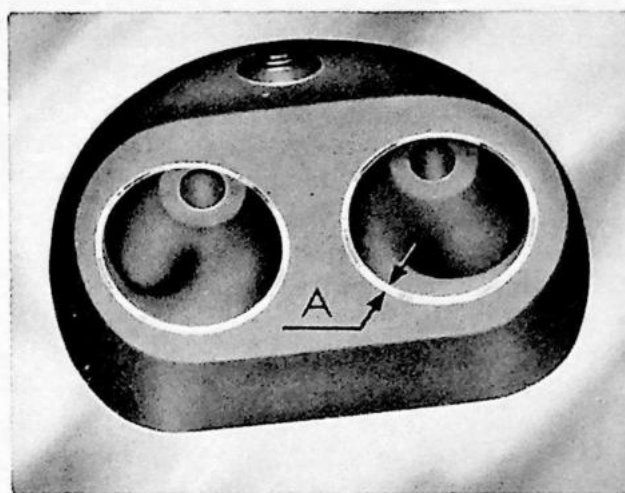
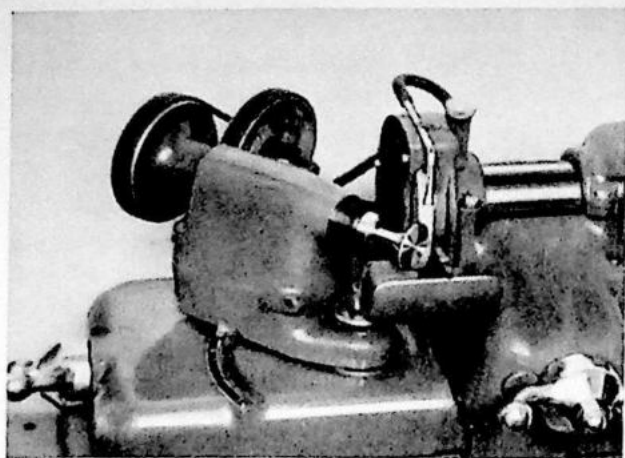


Fig. 54. Valve seat width.
A = 1.5 mm (0.060")

Valve grinding

Valve grinding comprises refacing of the valve disc sealing surface, cut-off grinding of the valve stem end and lapping-in of the valve disc against the valve seat with the help of an abrasive compound.

Machine grinding implies the use of a special grinding machine in which the valve is chucked and brought into rotation against the fine-grain grinding wheel which also rotates. The valve seat angle should be 44.5° . Before this operation is carried out, the valve should be completely free from carbon and oil. When the sealing face is finally ground, the edge of the valve disc



21200

Fig. 55. Valve grinding.

should have a thickness of at least 1 mm (0.04") on its outer edge. Otherwise the valves should be rejected since valves with thinner edges will soon become burned and warped.

For cut-off grinding of the valve stem end, place the valve in a vee-block and press the stem against the flat side of the grinding wheel at the same time as the valve is rotated.

After machine grinding, final lapping-in is done against the valve seat in the cylinder head. The valve sealing face should be covered with a small amount of abrasive grinding compound mixed with oil and then the valve should be fitted in its position in the cylinder head. The valve is then pressed against the seat and turned backwards and forwards a few times with a suitable tool. This is repeated a few times and then the seat and valve are thoroughly cleaned. Then check the sealing surfaces by applying a coat of marking paint to the valve sealing surface, inserting the valve in the guide, pressing it hard against the seat and giving it about one quarter of a turn. If the contact is satisfactory, the paint will cover the entire surface of the valve seat.

Fitting new valve seats

Note. Before a valve seat is replaced, always press in a new valve guide and ream it to the correct size.

If a valve seat is so badly burned that it cannot be reconditioned by milling or grinding, a new seat must be fitted. This is done by using a special milling cutter to remove the old seat completely and then by pressing in a ring of steel. It is very important to ensure that the new seat fits absolutely tightly and, for this reason, milling and

pressing in must be done very carefully. This operation requires special equipment with a milling attachment and drifting tools.

The new seat insert is cooled with carbon dioxide snow and is then pressed into place with the tool required. The new seat is then ground to the correct width and angle.

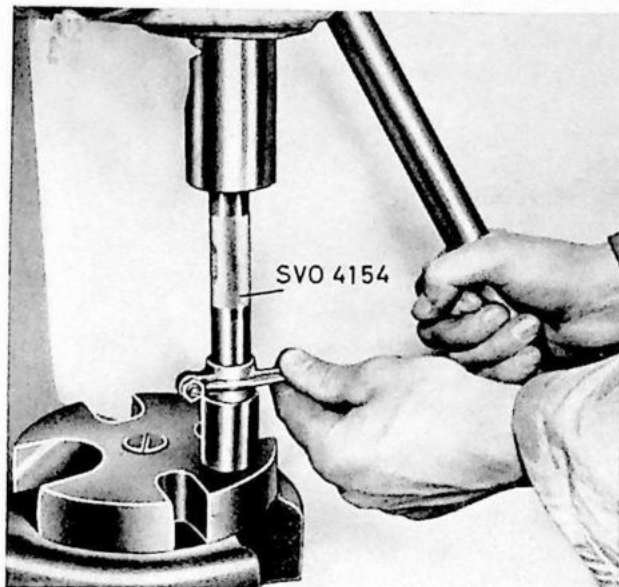
VOLVO
22631

Fig. 56. Replacing a rocker arm bushing.

Rocker arms

It is very important to ensure that the rocker arm bushings are not too much worn. The maximum permissible wear is 0.1 mm (0.004"). Make

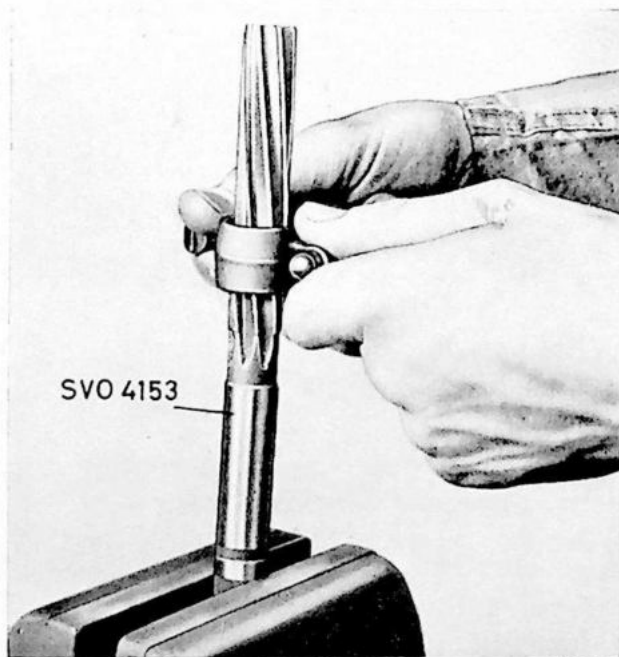
VOLVO
22632

Fig. 57. Reaming rocker arm bushings.

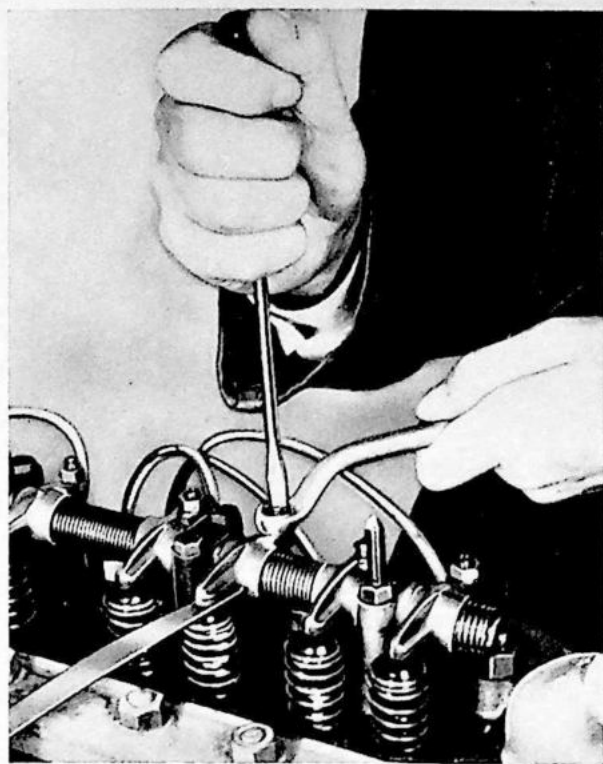


Fig. 58. Adjusting valve clearance.

sure that the rocker arm pad has the correct form relative to the valve stems, that the oil passages are not clogged and that the lock nut and the ball and thread on the adjusting screw are in good condition.

When fitting new bushings take care to turn them the right way. The hole in the bushing should form a 30° angle upwards towards the ball screw. Use tool SVO 4154 Fig. 56. A suitable sleeve should be used as support. The new bushings should be reamed with the special tool SVO 4153, Fig. 57.

The surface of the rocker arm pad is ground smooth with the help of a fixture to get rid of unevenness. Remember that the pads are hardened and, for this reason, the grinding depth should be restricted to a maximum of 0.5 mm (0.02"). The oil passages in the bushings should be blown clean with compressed air.

Replace adjusting screws and lock nuts if there is any fault whatsoever on the ball or the threads.

Rocker arm shaft

The rocker arm shaft should be replaced if the rocker arm journals are worn more than 0.05 mm (0.002"). A good shaft should be blown clean with compressed air.

Valve lifters

Valve lifters with worn or damaged bearing surfaces should be rejected and replaced.

Adjusting valve clearance

After an engine has been reconditioned, the first thing to do before starting is to make a preliminary adjustment of the clearances on all the valves. This is done as follows. All the spark plugs should be removed.

Number 1 piston is cranked to its firing position and while the engine is being turned in its direction of rotation notice the rocker arms on the fourth cylinder. When the exhaust valve on number four cylinder just closes, the piston in number one cylinder is in its firing position.

Back off the lock nut and turn the ball screw until the feeler gauge starts to jam. Then slacken the ball screw enough to allow the gauge to be moved back and forth with some resistance. Tighten the lock nut, taking care to ensure that the screw does not turn with it. Now move number four piston to the firing position by noting the closing of the exhaust valve in number one cylinder and adjust the valves on number four cylinder. Adjust the valves on cylinders numbers two and three in the same way. When the exhaust valve on number three cylinder closes, this means that number two piston is in its firing position and vice versa.

The valve clearances should be: Inlet valves 0.40 mm (0.016"). Exhaust valves 0.45 mm (0.018").

When all the valves have been adjusted, fit the spark plugs. Make sure that oil and water is added to the engine and then start the engine.

Final adjustment should be carried out when the engine has reached normal operating temperature and is idling slowly.

Flywheel

Replacing the flywheel bushing

If the flywheel centre bushing recess is so worn that the pilot bearing has become loose, the hole can be turned to increase the diameter to receive an insert ring. The diameter of the bearing recess should be $35 \pm \begin{smallmatrix} 0.006 \\ 0.010 \end{smallmatrix}$ mm ($1.378'' \pm \begin{smallmatrix} 0.0002'' \\ 0.0004'' \end{smallmatrix}$). The maximum runout may not exceed 0.025 mm (0.001").

Refacing the flywheel

If the face of the flywheel is scored or blued, it may be refaced by grinding.

Grinding should be carried out by using a special grinding attachment in a lathe, Fig. 59. The total depth available for grinding is restricted to 0.75 mm (0.03").

Replacing the ring gear

Remove the old ring gear with a hammer and drift. Heat the new ring gear up to about 180° C (355° F) and then place it on the flywheel, the beveled side of the teeth facing upwards. Then tap the gear lightly so that it seats well against the shoulder all round on the flywheel.

Pilot bearing

The pilot bearing in the flywheel should be replaced if play is evident or if, after cleaning, there are signs of damage to the balls, ball races or cages. Pull out the old bearing by using tool SVO 4090 and drive in the bearing with tool SVO 1426.

Lubricating system

Oil pump

Reconditioning

The most important requirement is that the pump shaft does not have too much clearance in the housing. Clean the pump and check this clearance. Worn or damaged bushings or shaft should be replaced. If the housing is scored on the inside it should be replaced. Shaft bushings should be pressed into position and reamed to size. Use a reamer with a guide bush. Holes for slotted pins are drilled after the gears have been fitted on the shaft. Before locking the driving gear in position, check that there is an axial clearance of 0.02 mm (0.003") and that gear backlash (Fig. 60) is between 0.15—0.35 mm (0.006—0.014"). The driven gear should be fitted with the ground side facing the pump housing cover. A scored cover can be refaced on a face grinding machine.

Before fitting the cover, measure the clearance between the cover and the gears. This should be 0.05 mm (0.002"). Measurement is carried out as shown in Fig. 61.

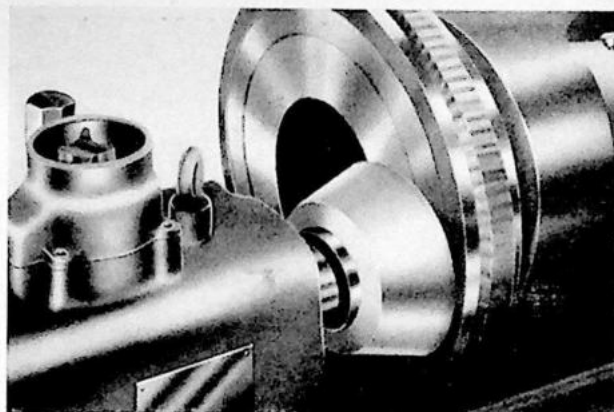
VOLVO
20173

Fig. 59. Refacing the flywheel.

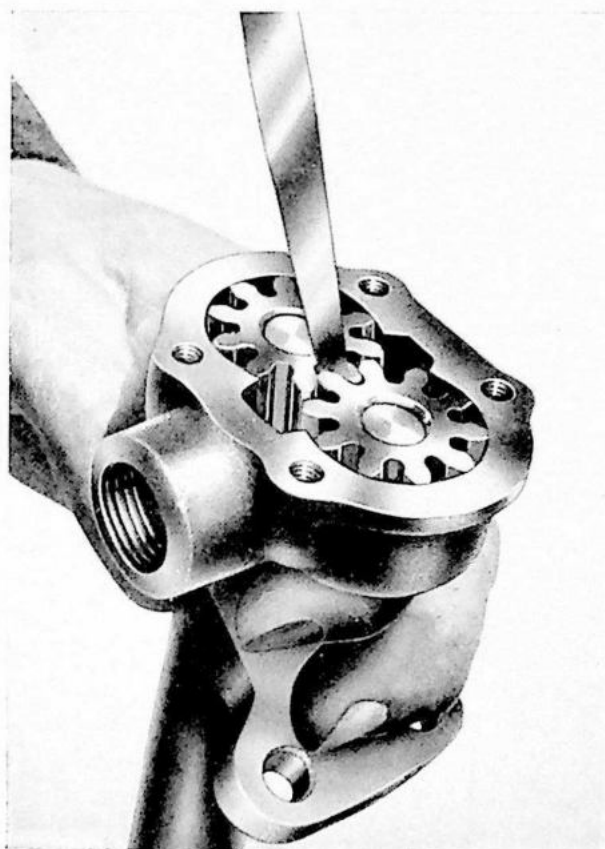
VOLVO
20301

Fig. 60. Measuring backlash.

Fitting the oil pump

The installation of the pump is facilitated if the distributor is removed and fitted back in position when the oil pump has been secured. With the engine cranked to 0° and number one cylinder in its firing position, the driving gear should be in the position shown on Fig. 62.

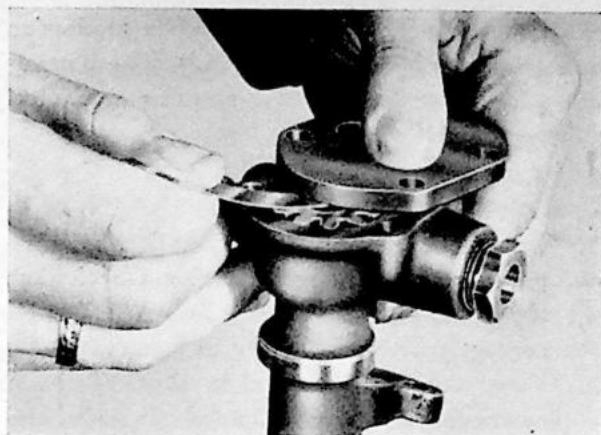
VOLVO
20360

Fig. 61. Checking axial clearance.

If a new pump driving gear has been fitted, ensure that it is made of the same material as the camshaft used in the engine. This means that a forged gear must be used together with a forged camshaft and a cast gear with a cast crankshaft. If the wrong combination is selected seizing can easily occur. Cast gears are phosphated (grey-black) and the camshaft can be identified by checking the part number which is stamped into the rear end of the shaft.

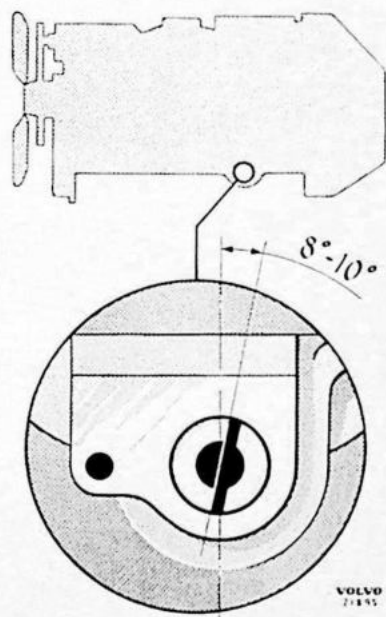
VOLVO
21895

Fig. 62. Driving gear position.

Relief valve

The relief valve plunger is extracted by using tool SVO 2079. Clean the plunger before refitting it. The spring should be tested in the manner shown in Fig. 51. If the spring does not hold the

specified length as shown in the specifications, fit a new spring. Oversize plungers can be fitted in re-conditioned engines. The plunger and the boss in the block are then marked 0.5 ö.d.

Oil passages

It is extremely important to ensure that the oil passages are perfectly clean and great care should be taken to ensure removal of all obstructions. The best way is to remove the seal plugs at the ends and scrape the walls of the passages by using a special brush. Flushing with water should then be carried out and blowing dry with compressed air. The rocker arm system oil passage should also be cleaned. This passage goes through the block and the cylinder head beside number 4 cylinder.

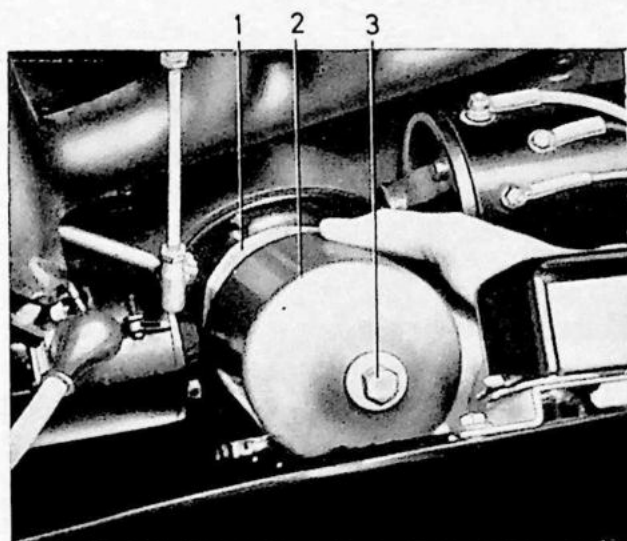
VOLVO
21967

Fig. 63. Replacing the oil cleaner element.

1. Element 2. Housing 3. Bolt

Oil cleaner, element replacement

The oil cleaner element should be replaced for the first time in a new or reconditioned engine after 5000 km (3000 miles), the second change after a total mileage of 10,000 km (6000 miles) and later replacement after every 10,000 km (6000 miles).

1. Clean the oil cleaner housing and the adjacent parts of the engine to prevent dirt from getting into the lubricating system when removing.

2. Loosen the center bolt (3) on the cleaner housing, Fig. 63. Collect the oil that runs out.
3. Remove the oil cleaner. Take out the old element and clean the housing with white spirit. The element cannot be washed but should be replaced with a new, original Volvo element which is especially made for this type of oil cleaner. If the wrong type of element is fitted there is a risk that the function of the lubricating system can be seriously disturbed.
4. Fit the element and gasket and then refit the housing. Check that the intermediary plate on late production units (11, Fig. 7) is located so that the side marked "UP" is at the top. Guide the housing with the hand so that it comes correctly into its groove. Tighten the bolt to a torque of 5 kgm (36 lb. ft.).
5. If the element is replaced without changing the engine oil, top up by adding 0.75 liters (1½ Imp. pints = 2 US pints) oil.
6. Clean the parts of the engine round the oil cleaner. Stop the engine and check for leakage at the gaskets.

Crankcase breather

The purpose of the crankcase breather is to remove vapour and blowby gases from the crankcase. This is done by means of a pipe on the left-hand side of the crankcase. If this pipe should become blocked, there will be a pressure rise in the crankcase and this can cause oil leakage. The oil filler cap filter and this crankcase breather pipe should be cleaned out every time major work is carried out on the engine.

Ignition system

Ignition setting

Accurate adjustment of ignition timing should always be carried out with the help of a stroboscope while the engine is running at rapid idling speed. The basic setting when assembling the engine is carried out with the help of a small bulb which is connected to the distributor. Final checking and adjustment should, however, always be done with a stroboscope.

During manufacture the setting is made for 87 octane fuel (Research Method). The setting values for other fuel octane values are included in the specifications.

Basic setting

1. Crank the engine to TDC and the firing point for number one cylinder. Check that the driving gear on the oil pump is in the correct position as shown in Fig. 62.
2. Turn the crankshaft about 1/4 of a turn backwards and then forwards again to the firing position, see the specifications, page 53. When rotating forwards check that the indicator pointer, Fig. 67, is registering the correct reading but does not go past it. If the crankshaft is rotated too far it should be rotated backwards and forwards again to the correct position so as to avoid a faulty reading depending on gear backlash.

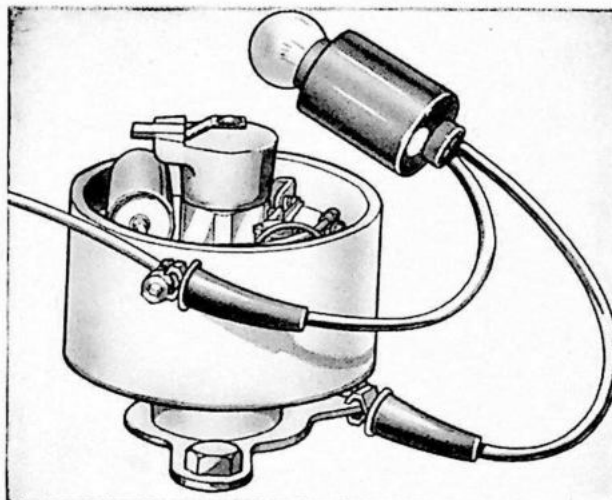


Fig. 64. Adjusting ignition timing.

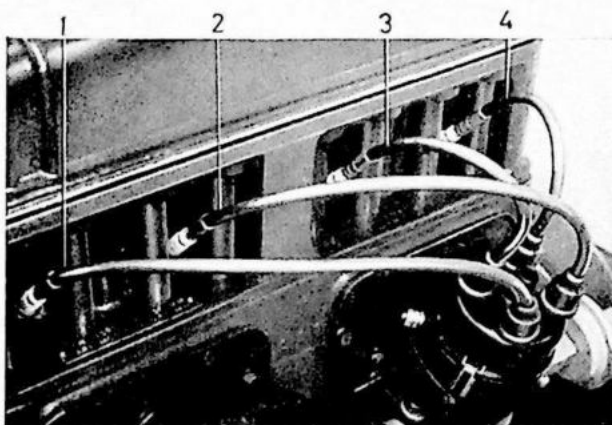


Fig. 65. Ignition cable attachments.

3. Turn the distributor coupling to the correct position and push down the distributor into position. Connect a lamp (max. 3 W) as shown in Fig. 64. Switch on the current.
4. Loosen the clamp screw on the attaching plate and turn the distributor housing in a clockwise direction until the breaker points close and then slowly in a counter-clockwise direction until the bulb just lights up (opening point). Tighten the distributor in this position.
5. Check that the rotor points to the terminal leading to number one cylinder. Fit the distributor cap and cables as shown in Fig. 65. The rotor moves clockwise. The order of firing is 1—3—4—2.

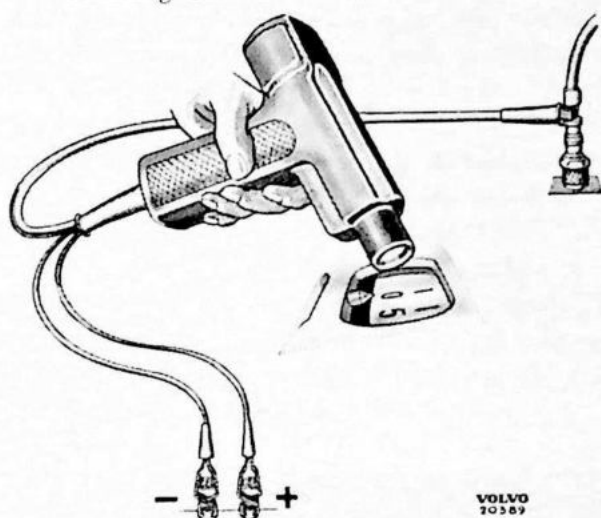


Fig. 66. Checking ignition timing.

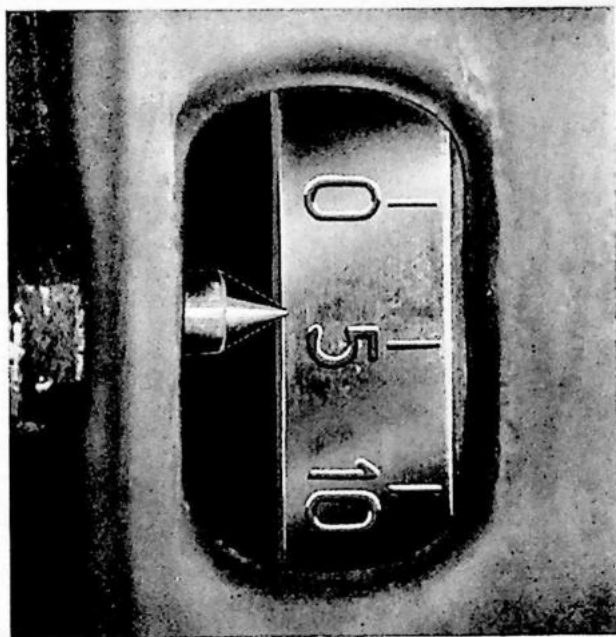


Fig. 67. Flywheel markings.

Fine adjustment

1. Disconnect the distributor vacuum regulator by loosening one end of the pipe.
2. Mark out the graduation, depending on the fuel grade used, on the flywheel by making a chalk mark. See page 53.
3. Connect up a lamp, Fig. 66, with the ignition cable to the spark plug in number one cylinder and the other cables to the battery.
4. Run the engine at 1500 r.p.m. and hold the lamp directed at the flywheel graduations. If the ignition setting is correct, then the chalk mark on the flywheel should appear to be stationary opposite the indicator.
5. If necessary adjust the setting by turning the distributor after loosening the clamp screws.
6. Remove the lamp and retighten the vacuum pipe.

Testing the spark plugs

After cleaning and adjusting the spark plugs, they should be tested in a special spark plug tester as it is not possible to judge their true condition from ocular inspection only.

Fit the spark plug in the tester and subject the pressure chamber to about 7 kg/cm² (100 lb./sq. in.). Connect the lead to the plug. If the plug is in good working order, a powerful spark would be seen through the inspection window when the switch is pressed in.

Fuel system

Carburetor

Removing

1. Blow the carburetor clean externally.
2. Remove the air cleaner, disconnect the fuel and vacuum pipes, throttle and choke linkages.
3. Remove the carburetor from the intake manifold. Cover the hole in the manifold with a suitable protector.

Disassembling and cleaning

1. Remove the four float bowl attaching screws and lift off the float bowl. See Fig. 68.
2. Remove the float lever and float. Both are marked "TOP" and early production units have a brass float. On late production units the float is made of nylon with a fixed arm.

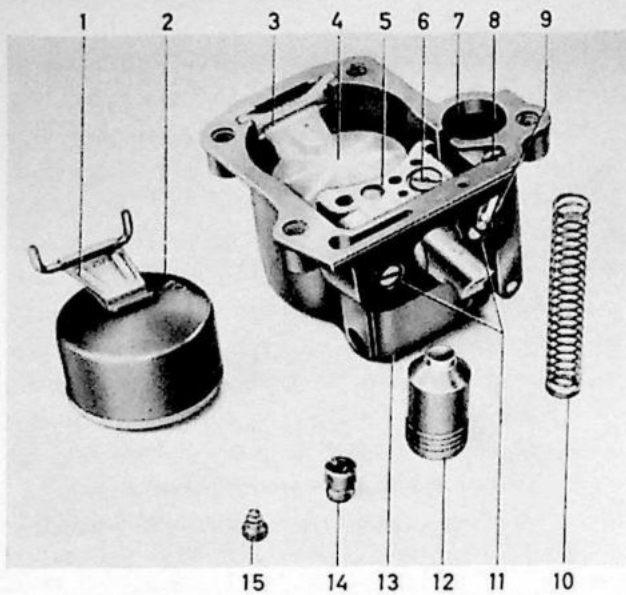


Fig. 68. The float bowl disassembled.

- | | |
|--|---|
| 1. Float arm (marked TOP) early production | 9. Acceleration jet |
| 2. Float (marked TOP) early production | 10. Spring |
| 3. Lock spring | 11. Attaching screws for emulsion block |
| 4. Float | 12. Plunger |
| 5. Emulsion block | 13. Float bowl |
| 6. Air jet for idling | 14. Inlet valve for acceleration pump |
| 7. Barrel for acceleration pump | 15. Check screw |
| 8. Outlet valve for acceleration pump | |

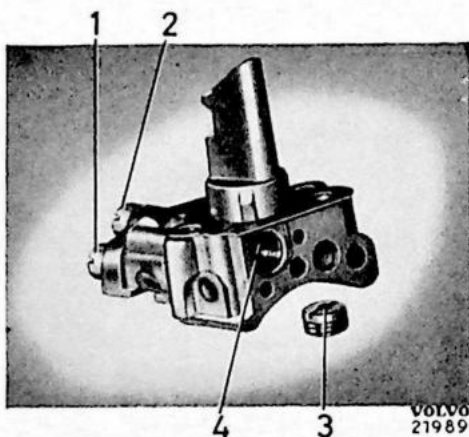


Fig. 69. Emulsion block.

1. Compensation jet (fine thread)
2. Main jet (course thread)
3. Idling air jet
4. Idling jet

3. Remove the screws (11) for the emulsion block, remove the block and take out the main jet (2, Fig. 69), the compensation jet

(1), the idling air jet (3) and the idling jet (4).

4. Remove the acceleration jet (9, Fig. 68), the outlet valve (8) and the check screw (15), the pump plunger (12) with the spring and then the inlet valve (14) located under the pump plunger.
5. Remove the valve for the float (2, Fig. 70). Be careful not to damage the valve washer. Remove the idling fuel screw.
6. Remove the attaching screws for the economiser valve (3) and remove the valve.
7. Clean the carburetor in white spirit (or alcohol which dissolves resin deposits better). Blow all channels and jets clean with compressed air. *Do not clean jets with steel wire or similar material since this can damage their calibration.*

Assembly

Assemble in the reverse order to that used when disassembling.

1. Check that all parts are in good condition and use new gaskets.
2. Make sure that the economiser valve disc (7, Fig. 70) seals correctly against its seat (5). Otherwise lap it with fine grinding compound but make sure that all traces of

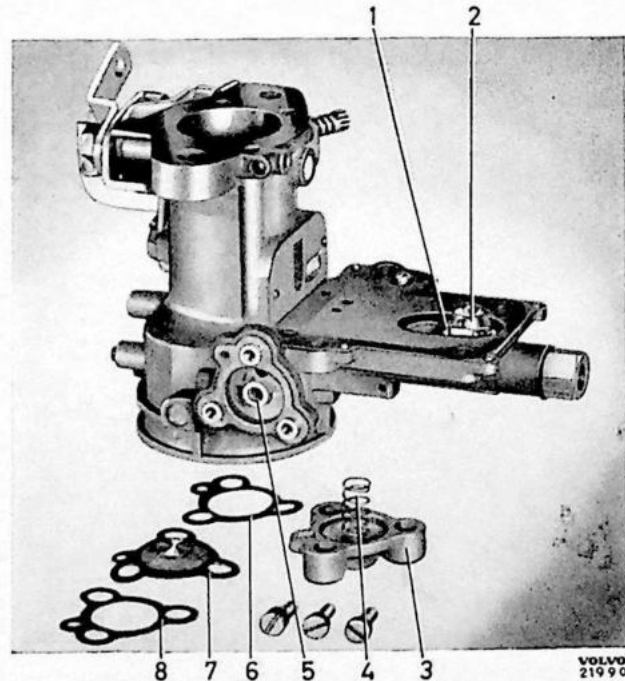


Fig. 70. Economiser valve.

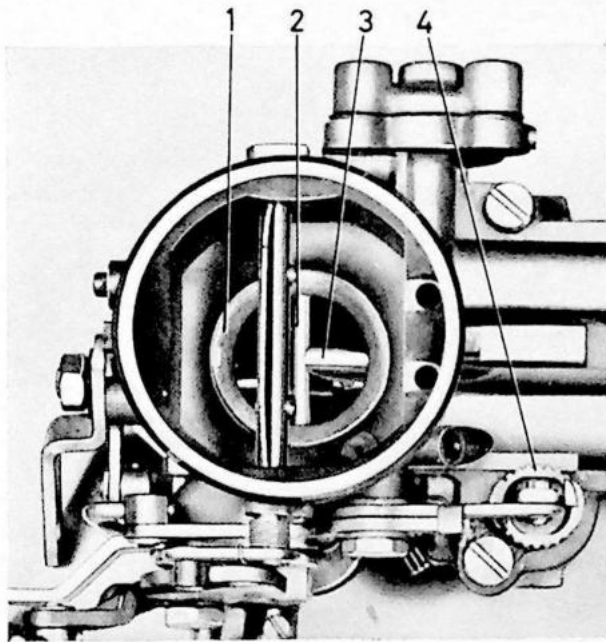
- | | |
|-----------------------|-----------------------------|
| 1. Float valve washer | 5. Air hole and valve seat |
| 2. Float valve | 6. Gasket |
| 3. Economiser valve | 7. Diaphragm and valve disc |
| 4. Spring | 8. Gasket |

this compound are washed off before the valve is finally assembled.

3. Turn the float and float arm so that the marking "TOP" faces upwards in the case of the brass float. The spindle should be placed so that the end points upwards, see Fig. 68. Place the lock spring (3) correctly on the nylon float with the center bent downwards so that the spring is not clamped against the float valve. Check that the spring (10) is located so that it is guided by the inlet valve (14). The downward movement of the plunger can otherwise be prevented.
4. Press the float bowl upwards and inwards against the carburetor body and then tighten the screws. Check that the emulsion block beak (3, Fig. 71) is in contact with the cross-stay (2) on the venturi (1). Otherwise loosen the screw (12, Fig. 8), push up the venturi, tighten the screw and secure it.

Fuel level

The fuel level, which should be 18 mm (0.70") below the float bowl surface while the engine is running, is determined by the float arm and the needle valve washer. The thickness of the washer should be 1 mm (0.040").



VOLVO
25397

Fig. 71. Venturi position.

- | | |
|---------------|--|
| 1. Venturi | 3. Emulsion block beak |
| 2. Cross-stay | 4. Washer for adjustment of acceleration pump stroke |

Acceleration pump stroke

The pump plunger can be adjusted to give a long or a short stroke by varying the position of the washer (4, Fig. 71). To alter this adjustment, lift the washer upwards and give it half a turn. Normally the washer should be set for a short stroke, i.e. with the highest cam turned towards the spring on the lever.

Adjusting rapid idling

When the carburetor is removed from the engine, rapid idling is adjusted as follows:

1. Place a 1.3 mm wire gauge between the throttle and the wall of the carburetor throat on the idling air jet side, Fig. 72. Make sure that the wire gauge does not come into contact with the venturi.
2. Loosen the screw (1) for the attachment (2).
3. Close the choke flap completely and move over the cam-shaped lever (4) until it is in contact with the stop (5).
4. With the lever against the stop and the wire gauge in the throttle as described in point 1 above, adjust the link rod (3) so that the check (9) on the lower lever just contacts the throttle lever (8) and then lock the link rod by means of the screw (1).

When the carburetor is fitted on the engine, the rapid idling setting can be checked as follows:

1. Screw out the idling adjuster screw (7, Fig. 72). Remove the spring, screw in the screw so far that the throttle just begins to open (a paper between the screw and the check starts to jam). Then screw in the screw 3 2/3 turns corresponding to the opening occurring when the wire gauge mentioned in point 1 above was inserted in the throttle.
2. Pull out the choke control on the instrument panel as far as it will go and check that the cam-shaped lever (4) contacts the stop (5). If the setting is correct the check (9) on the lever should just contact the stop on the throttle lever (8). Adjust, if required, by means of the screw (1) for the link rod (3).
3. Adjust idling speed.

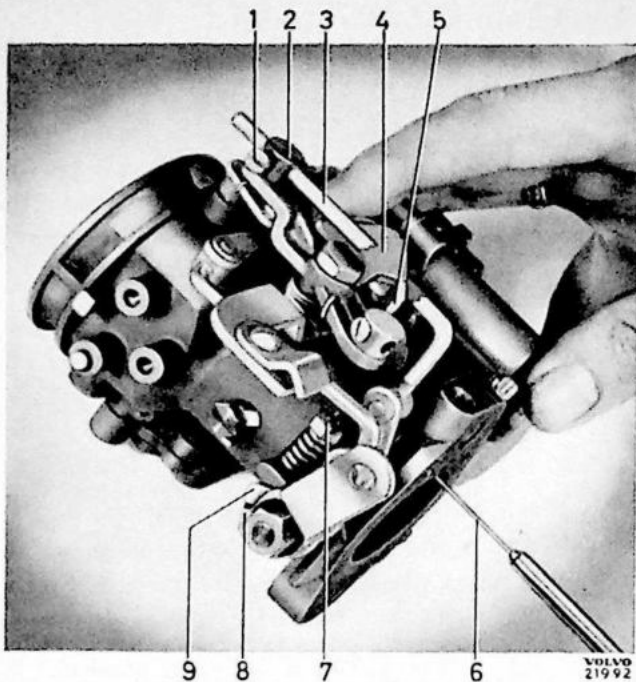


Fig. 72. Adjusting rapid idling.

1. Rapid idling adjusting screw
2. Attachment
3. Link rod
4. Cam-shaped lever
5. Stop
6. Wire gauge
7. Idle adjusting screw
8. Short lever for throttle
9. Check on rapid idling lever

Fitting

The carburetor is fitted in the reverse order to that used when removing. Make sure that the flanges are clean. Use a new gasket.

Adjusting idling speed

1. Run the engine until it is thoroughly warm.
2. Adjust the idling speed to 400—600 r.p.m. by means of the screw (7, Fig. 72), for idling speed.
3. Adjust the fuel/air mixture with the aid of the idle fuel adjusting screw (16, Fig. 9) until the engine runs evenly and steadily. First screw the screw inwards (leaner mixture) until the engine runs unevenly and then outwards (richer mixture) until the best idling is obtained.
4. Adjust the idling speed by means of the screw (7, Fig. 72) if necessary.

Fuel pump

Testing the fuel pump

If no fuel arrives at the carburetor, disconnect

the fuel pipe at the carburetor and work the fuel pump by hand. If no fuel issues from the open end of the fuel pipe, check that there is fuel in the tank and that the suction line is not blocked or damaged so that air is drawn into the pump.

The fuel pump is checked by using a special gauge or by connecting a length of hose to the suction side of the pump and holding the other end of the hose under the level of a vessel full of fuel. If the pump is then worked by hand, it should suck up the fuel with the pump 70 cm (28") over the level of fuel. If the pump does not do this, it must be disassembled and the diaphragm, valves and gaskets examined.

Replacing the diaphragm

1. Remove the screws securing the upper and lower halves of the pump housing and separate the halves.
2. Take the lower half in the left hand as shown in Fig. 73 and press the rocker (1) with the left thumb. Depress the washer (3) with the right-hand thumb and fore-finger. Then rotate one quarter turn and remove the washer, diaphragm (2) and pull rod.

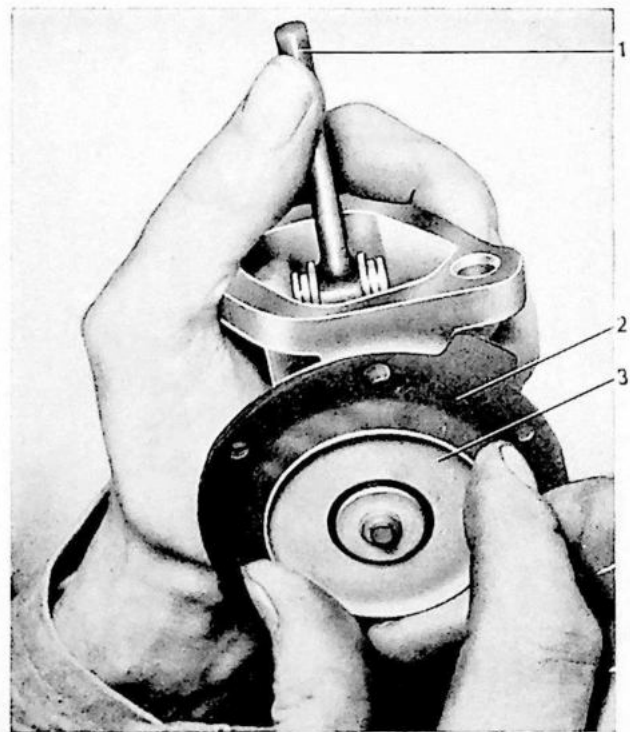


Fig. 73. Replacing the diaphragm.

1. Rocker
2. Diaphragm
3. Washer

The diaphragm, washer and pull rod are fitted into one unit so all three must be replaced.

Re-assembly is carried out in the reverse order to that used when disassembling. Make sure that the pump pull rod comes into its correct position on the rocker and that the diaphragm is clamped evenly between the two pump housing halves.

Replacing the valves

To replace the pump valves, separate the two halves of the pump housing. Then remove the two screws retaining the valve holder and take out the valves.

Check when fitting new valves that they are turned the right way and that the gaskets are in good order.

Repairing the fuel tank

If the fuel tank is leaking it must be soldered. Remove the tank and drain off all fuel thoroughly. Then wash through the tank carefully with hot water or steam for a period of at least ten minutes.

Clean the soldering point carefully before soldering and apply a smooth coat of tin. Use an electric soldering iron if possible.

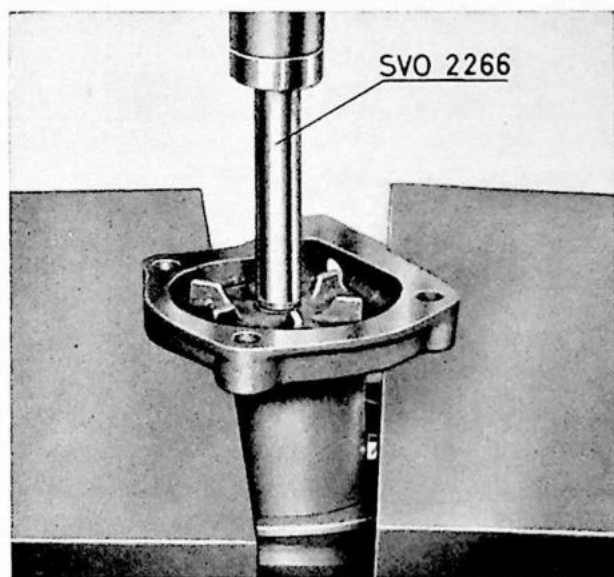


Fig. 74. Removing the impeller and shaft with ball bearing.

While soldering is going on, flush compressed air through the tank in order to prevent a concentration of gases that could produce an explosion.

Running on alcoholic fuel

When the engine is run on normal gasoline, gum deposits are formed inside the tank, since the fuel contains small quantities of resin. Alcohol can dissolve these deposits. If you are going to start using alcohol fuel, before this fuel is used the tank must be removed and cleaned internally with alcohol.

This cleaning can be carried out by filling the tank with alcohol and leaving it to stand for some time after which it should be drained and thoroughly flushed out. The fuel lines to the fuel pump and carburetor must also be flushed out.

Fuel

Fuel with an octane rating (Research Method) of 87 to 97 should preferably be used. If fuel with an octane rating of 83 (Research Method) is used the ignition timing setting must be altered (ignition retarded). This is however not to be recommended since it decreases engine output.

Cooling system

Water pump

Removing

Drain off the cooling water. The water pump can be removed without it being necessary to take off the radiator. First loosen the fan, which is attached by means of four bolts to the pulley. Remove the pulley belts. Then take off the four bolts retaining the pump to the block and take out the pump.

Disassembling

1. Remove the lock screw (3, Fig. 18) for the rear ball bearing. Press out the shaft by using tool SVO 2266, Fig. 74. Guide the pulley with your hand to avoid the shaft from binding. Remove the impeller. The ball bearing and the spacer usually come out with the shaft (if the ball bearings remain in the housing, remove the seal and then press out the bearings with the thick end of tool SVO 2266).
2. Turn the pump housing and remove the seal ring with tool SVO 2266. Screw out the lubricator.

3. Remove the oil slinger. Place the fixture SVO 2271 in the press with the large diameter downwards. Press down on the shaft with tool SVO 2266 through the fixture whereby the pulley, ball bearing and spacer come loose, see Fig. 75.

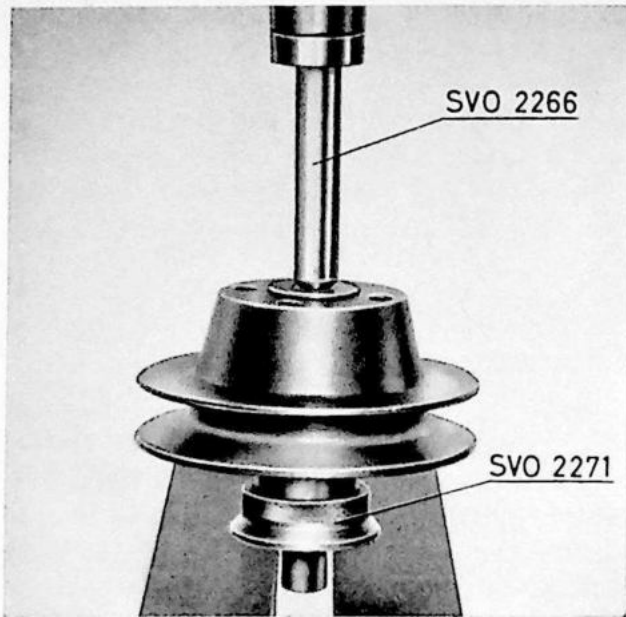


Fig. 75. Removing the pulley.

Inspection

Wash all parts carefully before inspecting for damage. The bearings should rotate freely without binding and the sealing ring must be free from cracks and press firmly and smoothly against the impeller.

Replace damaged and worn parts.

Assembly

On late production units, the pulley has been extended by 7 mm compared with earlier production units. This 7 mm extension should be outside the end of the shaft. The corresponding fan has its attaching level moved forward by the same distance. If this late model fan should be fitted on the short pulley, a spacer sleeve and longer bolts must be used. Long pulleys and early production fans may not be assembled together. The result will be that the fan comes too near the radiator.

1. Place the front bearing on fixture SVO 2271 with the protector plate downwards. See Fig. 76. Press down the shaft into the ball bearing so that the end of the shaft

bottoms against the base plate and then press the pulley so that the end of the shaft (early production) is level with this. Place a 7 mm long rod under the shaft in the case of late production units.

2. Place the spacer sleeve in position, turn the shaft and then press on the second ball bearing with fixture SVO 2271. Turn the ball bearing so that the open side faces the spacer sleeve. A fixture should be located as shown in Fig. 75 and the press tool applied directly to the pulley but with the earlier mentioned 7 mm long rod against the shaft in the case of long pulleys. Fit the lubricator in the housing.

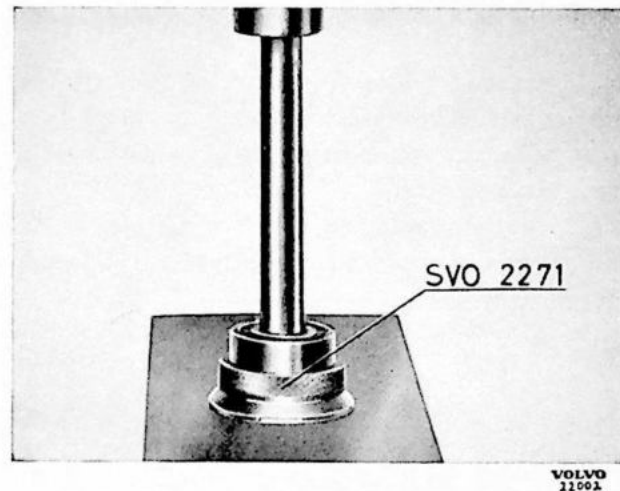


Fig. 76. Fitting the ball bearing.

3. Fit the shaft with the ball bearings, etc. as a unit in the housing. Make sure that the shaft goes straight in when pressing. Screw in the stop screw for the rear ball bearing.
4. Install the oilslinger (7, Fig. 18) with the flange turned away from the bearing. Fit the seal ring (4) with tool SVO 2270.
5. Fit the impeller with tool SVO 2266, placing the large end towards the impeller.
6. Check that the pulley rotates easily. The impeller should be 0.3 mm under the level of the pump housing, this being checked by means of a straight edge and a feeler gauge. The clearance between the impeller rear face and the housing should be 0.5—1 mm (0.02—0.04").
7. Fill the pump with heat-resistant grease.

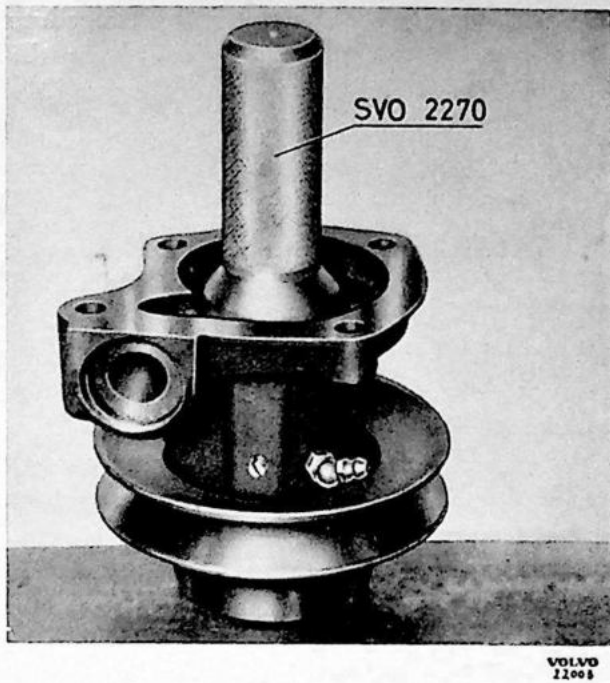


Fig. 77. Fitting the seal ring.

Fitting

The water pump is fitted in the reverse order to that used when removing. Always use a new gasket between the pump housing and the engine block. Check hose connections and replace if the hose in question is soft and swollen.

Thermostat

The thermostat has a very important function, namely that of helping the engine to attain its correct working temperature as soon as possible after starting. For this reason the thermostat must not merely be removed if it should prove to be defective but a new thermostat should be fitted immediately. Cylinder wear and corrosion are especially prominent when the engine is cold. The function of the thermostat is to block the passage for the water from the engine to the radiator through the upper radiator hose so that the water in the engine cannot pass to the radiator. This means that the water rapidly attains a suitable working temperature and cylinder wear is reduced. Inside the engine itself, the water can circulate through a by-pass to ensure heat distribution without local overheating.

If it is suspected that the thermostat is faulty, it can be removed and tested. This is done by tying the thermostat to a piece of wire and hanging it in a beaker full of water together with a

thermometer. Fig. 78. Make sure that the thermometer does not rest on the bottom of the beaker. Heat up the water and watch the thermostat. It should not open before a temperature of $75^{\circ}\text{C}=167^{\circ}\text{F}$ ($72^{\circ}\text{C}=162^{\circ}\text{F}$ on early production units) and it must not open later than a temperature of $78^{\circ}\text{C}=172^{\circ}\text{F}$ ($76^{\circ}\text{C}=169^{\circ}\text{F}$ on early production units). The temperature of the water should then be raised to $90^{\circ}\text{C}=194^{\circ}\text{F}$ ($85^{\circ}\text{C}=185^{\circ}\text{F}$ for early production units) when the thermostat should be fully open. If the thermostat does not open at the above temperatures, a new thermostat should be fitted.

Radiator

If the radiator leaks it should be soldered. If the leak is somewhere in the cellular system, the radiator must be removed and tested. The reason for this is that the position of the leak must be accurately located before soldering is carried out.

The radiator is tested by connecting a compressed air hose to one radiator pipe and sealing off the other. Use a reduction valve to take the pressure down to max. 0.2 kg/cm^2 (3 lb./sq. in.). Submerge the radiator in water and trace air bubbles issuing from it.

Removing the radiator

Disconnect the radiator blind wire and drain off the cooling water from the engine. If the water contains anti-freeze, collect the water in a clean vessel. After disconnecting the upper and lower radiator hoses and removing the bolts on either side of the radiator, lift up the radiator.

Blocked radiator

Blockage can be avoided by using clean water (preferably rain water) with rust inhibitor added.

If it is suspected that the radiator may be wholly or partially blocked, check by feeling the front of the radiator while the engine is running. If part of the radiator front feels cold in spite of the fact that the engine is running at an abnormally high temperature, this means that the radiator cells are blocked.

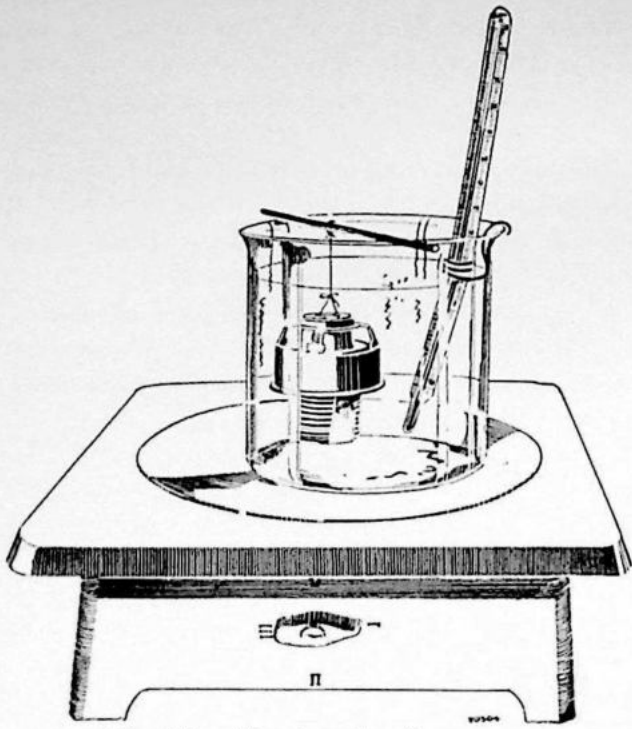


Fig. 78. Testing the thermostat.

It is sometimes difficult to clean out a blocked radiator. An attempt can be made by using a solvent, for example ordinary soda, 250 grams (9 oz.) dissolved in 5 litres (5 quarts) of warm water. Then fill up the rest of the radiator with water. If caustic soda is used, take about half the quantity in the same amount of water i.e. 125 grams (4½ oz.) in 5 litres (5 quarts) of water. Let this solution remain in the cooling system while the engine is run for about 4 hours. Then empty the cooling system and flush out thoroughly with water. Flushing should be carried out preferably against the normal direction of circulation.

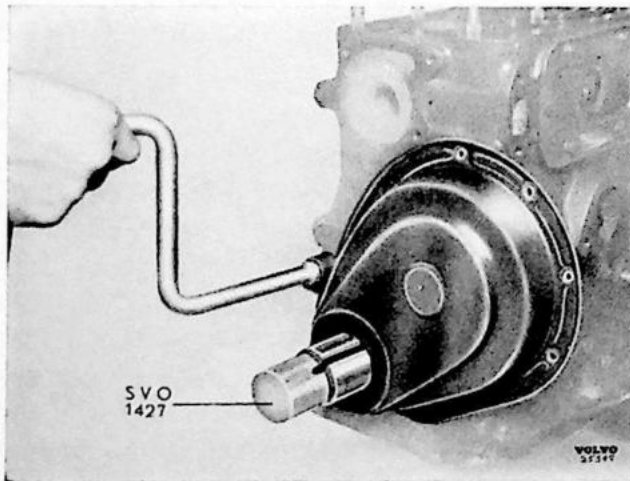


Fig. 79. Fitting the timing gear casing.

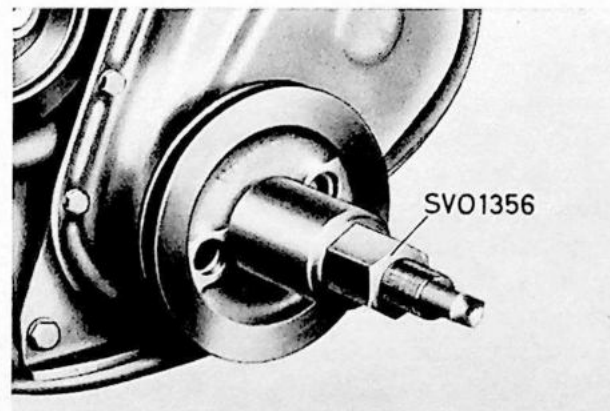


Fig. 80. Fitting the pulley.

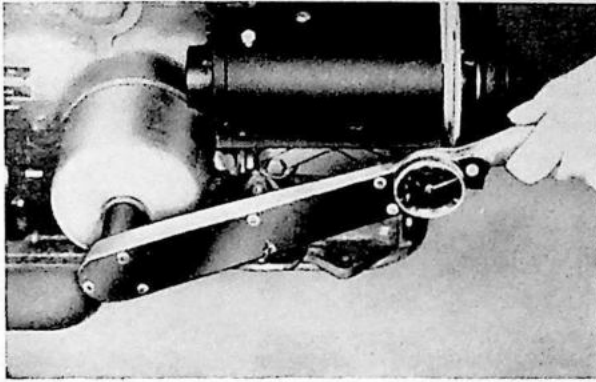
If necessary, repeat this cleaning procedure once more. If this has no results, have the radiator cleaned in a special workshop or fit a new radiator.

Anti-freeze

To prevent freezing of the water in the engine during cold weather, anti-freeze should be added. Ethylene glycol is an effective anti-freeze which raises the boiling point of the water to a point above $100^{\circ}\text{C} = 212^{\circ}\text{F}$. Ethylene glycol is not volatile.

Methylated spirit which is used in some cases has the disadvantage that it evaporates even at normal engine temperatures. This makes regulator control essential. In addition to this the surface finish on the car can be very seriously damaged if methylated spirits should happen to splash onto it. The following should be carried out before adding anti-freeze:

1. Flush out the cooling system thoroughly.
2. Check that the radiator is not leaking. Examine all rubber hoses (do not forget the heater).
3. Tighten the cylinder head nuts and then re-check the valve clearance. Make sure that all hoses and gaskets are in condition. Replace hose clamps and gaskets which are not sealing correctly. Do not forget the radiator filler cap gasket.
4. Check that the thermostat is in good order.
5. After the anti-freeze is drained off in the spring, the cooling system must be thoroughly flushed out. Flush out in the opposite direction to the normal circulation.



VOLVO
22667

Fig. 81. Tighten the oil cleaner bolt.

In order to determine the amount of anti-freeze to be added to the cooling system to provide protection for certain temperatures, see the specifications on page 50.

Reassembling the engine

When reassembling the engine use a suitable stand to support the engine block.

A suitable order of work is the reverse to that used when disassembling the engine. See page 15.

It is very important during assembly to ensure that all parts are well cleaned and lubricated where possible and that all gaskets, washers and other seals are carefully fitted. The table in the specifications on page 51 shows the torque values to be used for various bolts and nuts.

Pack the flywheel ball bearing with heat-resistant grease before fitting. Use tool SVO 1426 to drive in the bearing. Secure the flywheel nuts with new washers.

The clutch, flywheel and crankshaft are balanced to one unit which is marked with paint. Make sure that the parts are fitted in their correct positions according to the markings.

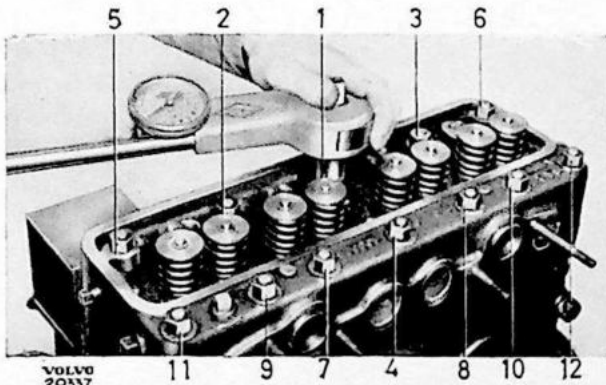


Fig. 82. Tightening sequence for cylinder head nuts.

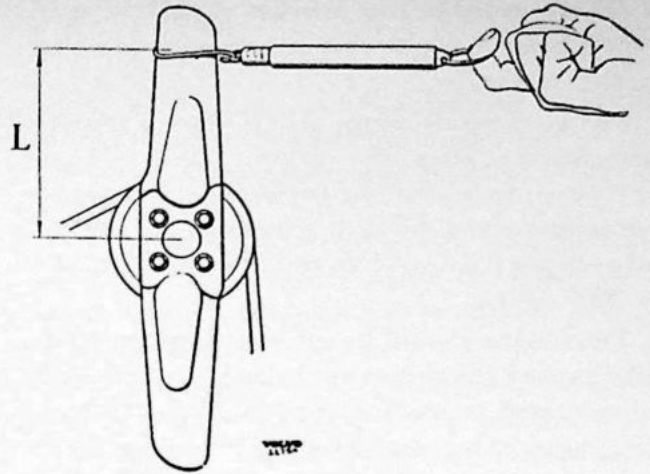


Fig. 83. Pulley belt tension.
L=150 mm (6") Pull 5.5—6.5 kg (12—14½ lb.)

Use tool SVO 1356 to fit the crankshaft pulley and camshaft gear. Make sure that the generator tensioner arm is clean and free from paint on the contact surfaces to ensure good grounding.

Always use new washers, gaskets and seals. The timing gear casing must be well centered to ensure that it seals effectively against oil. This is done by using tool SVO 1427, see Fig. 79. It is extremely important to ensure that the cylinder head nuts are tightened in the correct sequence, as shown in Fig. 82. If the nuts are tightened without any system at all, this can lead to unnecessary stresses in the block.

The fan belt must be tensioned so that the pulley starts to slip when a pull of 5.5—6.5 kg (12—14½ lb.) is applied at a point 150 mm (6") from the hub center, in the direction of engine rotation, see Fig. 83.

Fitting the engine in the car

The engine is fitted in the car in the reverse order to that used when removing it. Take care not to damage the surface finish or cables. Tighten the engine thoroughly on its mountings but not too hard. Use new lock washers and cotter pins.

Running-in the engine

A reconditioned engine or an engine on which new pistons, piston rings, main bearings or connecting rod bearings have been fitted must be run with great care after starting and during the first running-in period, in order to ensure that the new parts wear in correctly.

Where possible test benches should be used for running-in. Check that oil and water is added to the engine.

The oil pressure gauge should show a reading immediately after the engine starts. If no pressure is indicated, the engine must be stopped immediately and the fault remedied. The normal oil pressure is 2.5—3.5 kg/cm² (36—50 lb./sq. in.) at 2000 r.p.m.

The engine should be allowed to go at rapid idling speed for an hour or so and then it should be subjected to loading at the same time as engine speed is increased to about 1000 r.p.m. Test-bench running-in should cover a period of at least three hours. The oil should be changed after this running-in period.

If the above-mentioned test-bench is not available, the engine should be fitted directly in the car and oil and water added before it is started. Keep your eye on the oil pressure gauge. The engine should be set at rapid idling speed and be allowed to run for some hours.

Check now and then that oil pressure and cooling water temperatures are normal and that there are no abnormal sounds or leakage. Before the engine is subjected to loading, the cylinder

head nuts should be re-tightened and valve clearance adjusted. In order to avoid having to remove the rocker arm shaft, use tool SVO 2264 together with an extension and a torque wrench for the nut under the rocker arm shaft. If the extension is so long that it goes right through the tool and fouls the cylinder head, grind it off.

Change the oil when running-in is completed. The complete running-in however is not yet completed and care must be taken to follow the instructions in the car instruction book.

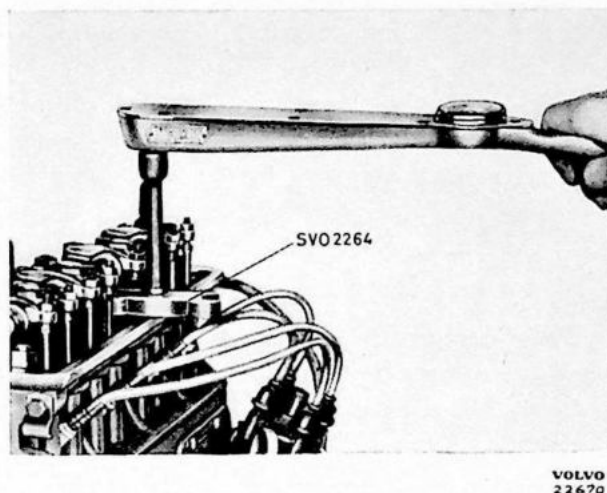


Fig. 84. Re-tightening the cylinder head nuts.

FAULT TRACING

Before having a look through the engine, or attempting to dismantle it, always remember the following points:

When complaints are made about excessive fuel or oil consumption or lack of power, the first course is to find out under what conditions the vehicle is operated.

Question the driver about the nature of operation and about his manner of driving.

Also ask him to take you for a short run and observe his driving habits.

Rapid acceleration, racing the engine, high

idling speed setting, and high cruising speeds all produce high fuel and oil consumption.

High oil consumption may be effect of an too high an oil level.

The oil need not be replenished until the level has fallen to, or slightly above, the lower mark on the dipstick. It must never be allowed to drop below this mark.

Various instruments can be used for fault tracing and the instructions for use with each individual instrument should be carefully followed.

FAULT	
REASON	REMEDY

Engine will not start

No fuel in carburetor

- No fuel in tank.
- Fuel pump diaphragm faulty.
- Leaking fuel pump valve.
- Fuel filter clogged.
- Leaking filter gasket.
- Fuel line clogged, or leaky.
- Fuel tank vent hole stopped.

- Fill fuel.
- Replace diaphragm.
- Replace defective valve.
- Dismantle and clean.
- Replace defective gasket.
- Flush out, trace and repair leak.
- Remove filler cap and clean.

Ignition system

- Spark plugs fouled, breaker point gap too large.
- Distributor defective.
- Battery run down.

- Clean plugs, adjust gap, and test or replace plugs.
- Inspect, adjust.
- Check acid specific gravity and recharge if below 1.230.
- Test and replace if necessary.
- Test and replace if necessary.
- Replace.

- Condenser defective.
- Ignition coil defective.
- Damaged suppressor on spark plug.

Carburetor

- Choke flap binding
- Fuel inlet valve or jets clogged.
- Defective gaskets.
- Air cleaner clogged.

- Check that spring can close flap.
- Dismantle and clean carburetor.
- Replace with new gaskets.
- Clean it.

Low compression

- Cylinders, pistons or piston rings worn or stuck.
- Valves sticky.
- Cylinder head gasket defective.

- Measure compression in all cylinders.
- Replace gasket.

Hard starting

Carburetor

Improper fuel level in float bowl.
 Faulty float or valve.
 Clogged jets or passages.
 Flooding.

Verify cause, and effect adjustments.
 Dismantle and clean carburetor.
 Check needle valve and float. Clean or replace.

Oil

Thick or dirty oil.

Change oil.

Engine will not idle

Carburetor

Improper fuel level in float bowl.
 Leaky float valve.
 Idling jet clogged
 Wrong idle setting, idling screw or idling air screw setting.
 Defective gasket between carburetor and intake manifold.
 Leak at vacuum pipe connection.

Check, adjust.
 Clean jet.
 Perform all idle adjustments.
 Replace gasket.
 Examine and repair.

Hard starting (cold)

Choke flap not closed.

Remove air cleaner. Pull out knob on instrument panel to see if spring on choke spindle can close choke flap. Clean spindle and bearings, replace spring if necessary.
 Check setting, see "Adjusting rapid idling".

Rapid idling faultily adjusted.

Excessive fuel consumption

Leakage

Damaged fuel tank.
 Damaged fuel line.
 Leaky nipples and fittings.

Check for leaks, and repair.
 Replace damaged part.
 Tighten or replace defective part.

Ignition system

Defective ignition timing.
 Defective distributor.
 Defective ignition coil.
 Defective condenser.

Adjust ignition timing.
 Test and adjust.
 Test and replace if irreparable.
 Test and replace if necessary.

Carburetor

Mixture too rich.
 Air cleaner clogged.
 Economiser valve diaphragm or washers leaking.

Adjust settings. See below under "Fuel system".
 Clean thoroughly.
 Check that screws are tight. Replace washers or diaphragm.

Acceleration pump outlet valve ball jammed in upper position.

Remove valve and clean in alcohol or replace.

Excessive oil consumption

Leakage

Leaky oil pan gasket.
 Leaky gasket between fuel pump and cylinder block.
 Damaged oilslinger or felt washer in timing gear casing.
 Defective sealing at rear main bearing.
 Blocked drain hole at front or rear seal.

Defective gasket on oil cleaner.

Cylinders, pistons, piston rings

Worn cylinders, pistons or piston rings.

Gummed or broken gudgeon pins.

Worn valve guides.

Replace gasket.

Replace gasket.

Replace damaged parts.

Replace felt seal.

Check holes are open when replacing felt seals.

Replace gasket after checking.

Check compression pressure in all cylinders; see "Compression Test".

Replace.

Replace.

Low oil pressure

Oil pressure gauge

Pressure gauge damaged.
 Clogged oil line to gauge.

Test gauge, replace faulty gauge.
 Clean replace if damaged.

Relief valve

Plunger stuck in open position.
 Broken or weak spring.
 Plunger worn.

Dismantle valve and replace plunger.
 Replace spring.
 Replace with new plunger.

Oil strainer and pipe

Strainer clogged up.
 Leak in output pipe.

Clean.
 Examine.

Oil pump

Worn gears.

Replace pump.

Main and connecting rod

Bearings damaged or worn.

Replace bearings, If crankshaft damaged, regrind journals.

Oil cleaner

Element blocked.
 Faulty bypass valve in cleaner.

Fit new element.
 Replace valve.

Engine does not deliver full power

Low compression

Worn clinders, pistons, piston pins.
Valves sticking.

Check compression in all cylinders.
Grind valves.

Fuel tank, lines, and pump

Improper fuel.
Leaking valves in fuel pump.
Filter clogged.

Drain tank and clean.
Replace valves.
Dismantle and clean filter.

Carburetor

Air cleaner blocked.
Jet clogged.
Carburetor adjustment disturbed.

Dismantle filter and flush clean.
Clean jets.
Clean and adjust carburetor.

Engine overheats

Coolant

Too little water in cooling system.

Add water.

Water pump and thermostat

Fan belt slips.
Pump impeller damaged.
Thermostat defective.

Tighten belt.
Replace impeller.
Replace thermostat.

Radiator, coolant hoses and passages

Radiator stopped.
Hoses or passages stopped by dirt and sludge.
Water distributor pipe clogged.

Clean.
See under "Stopped radiator".
Dismantle and clean pipe.

Ignition timing and carburetion

Wrong ignition timing.
Too lean fuel mixture.

Adjust ignition timing.
Clean and adjust carburetor.

Engine misses

Fuel tank, lines, and pump

Improper fuel, or water in fuel.
Fuel line partly obstructed.
Fuel pump defective.

Drain tank, flush out, and fill new fuel.
Examine and flush.
Verify cause and replace damaged part.

Distributor

Poor contact in coil terminal.
Loose contact in primary circuit.
Open or short-circuit in primary circuit.
Defective ignition cables.

Examine and adjust.
Examine and adjust.
Trace fault and effect corrections.
Clean connections. Replace cables if insulation poor.
Check and adjust.
Replace.

Faulty contact breaker gap.
Burned breaker points.

Carburetor floods or leaks

Float system

Dirt in inlet valve.
 Valve or valve seat worn.
 Float damaged.
 Fuel pump pressure too high.
 Fuel line leakage at fitting.
 Fuel level faulty through wrong washer thickness.

Clean valve and seat.
 Replace damaged parts.
 Repair float.
 Check pressure.
 Replace defective line or fitting.
 Check correct washer fitted between float valve and cover.

Jerky running when accelerating suddenly

Acceleration system

Leaking inlet valve.
 Strainer clogged.
 Plunger binds — impurities in barrel.
 Acceleration jet clogged.

Replace valve.
 Clean strainer.
 Clean acceleration pump.
 Clean acceleration jet.

Uneven idling

Idling system

Idling air screw wrongly set.
 Dirt in idling jet.
 Idle port partly blocked.

Adjust.
 Remove and clean.
 Remove carburetor, clean port.

Air leakage

Air leak at carburetor gaskets.
 Air leak at vacuum pipe connection.

Replace defective gasket or tighten bolts.
 Adjust.

TOOLS

The following special tools are required when carrying out repair and service work on the engine and water pump.

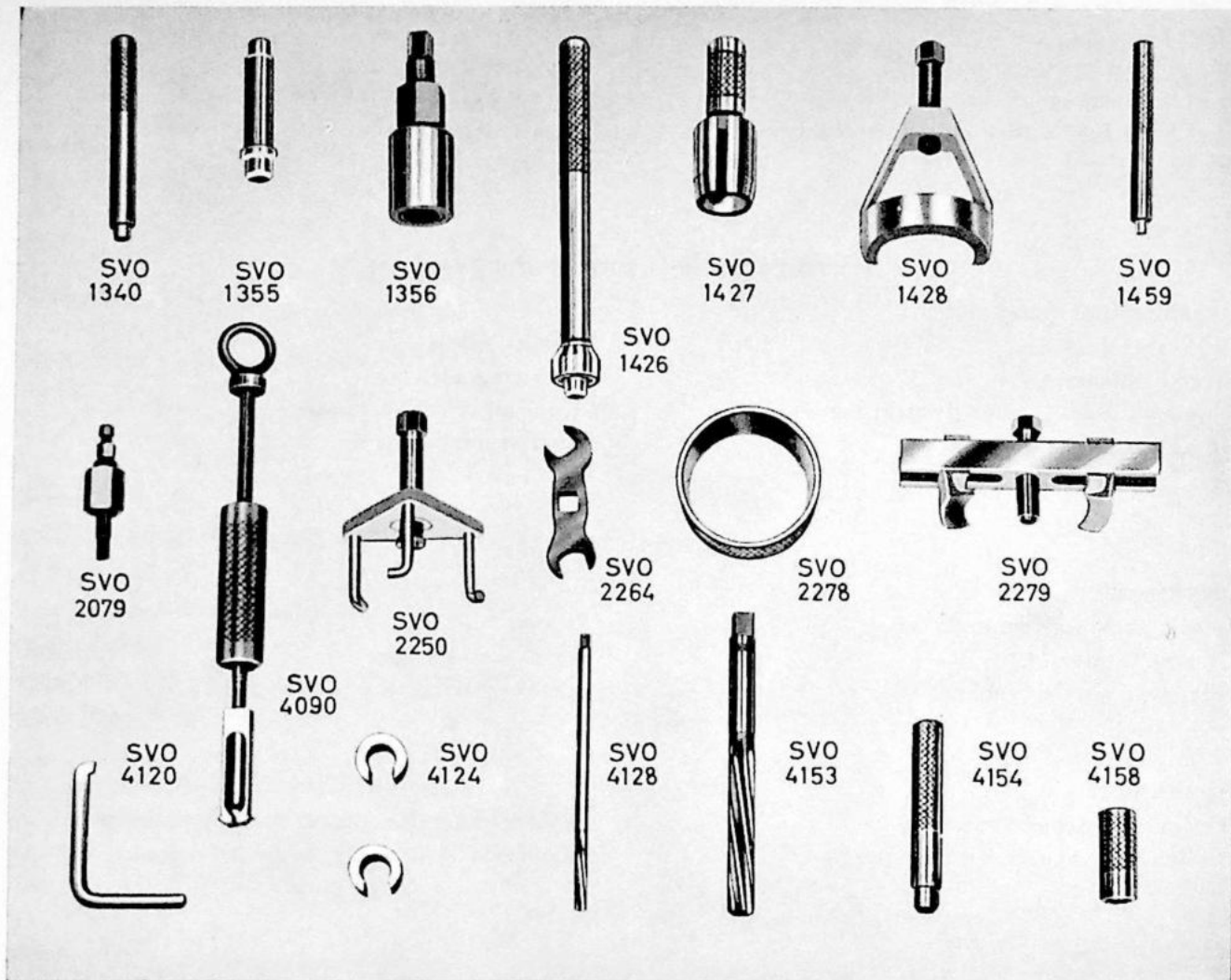


Fig. 85. Special tools for engine.

VOLVO
22634

- | | | | |
|----------|---|----------|--|
| SVO 1340 | Drift for removing and fitting piston pins. | SVO 2264 | Wrench for tightening cylinder head nuts under rocker arm shaft. |
| SVO 1355 | Drift for removing and fitting connecting rod bushings. | SVO 2278 | Instillation ring for pistons. |
| SVO 1356 | Press tool for camshaft gear and crankshaft pulley. | SVO 2279 | Puller for crankshaft pulley and generator. |
| SVO 1426 | Drift for fitting ball bearing in flywheel. | SVO 4090 | Pulley for ball bearing in flywheel. |
| SVO 1427 | Centring tool for timing gear casing and crankshaft gear. | SVO 4120 | Puller for water distributor pipe. |
| SVO 1428 | Puller for crankshaft gear. | SVO 4124 | Spacer for engine supports (2). |
| SVO 1459 | Drift for removing valve guides. | SVO 4128 | Valve guide reamer. |
| SVO 2079 | Puller for oil relief valve plunger. | SVO 4153 | Reamer for rocker arm bushings. |
| SVO 2250 | Puller for camshaft gear. | SVO 4154 | Drift for removing and fitting rocker arm bushings. |
| | | SVO 4158 | Drift for fitting valve guides. |

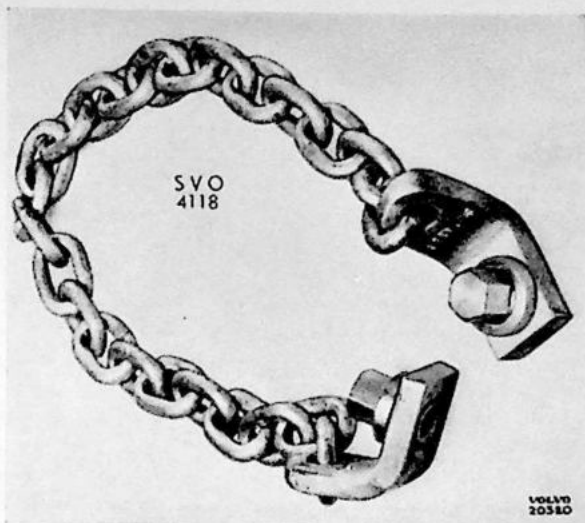


Fig. 86. SVO 4118 Lifting chain.

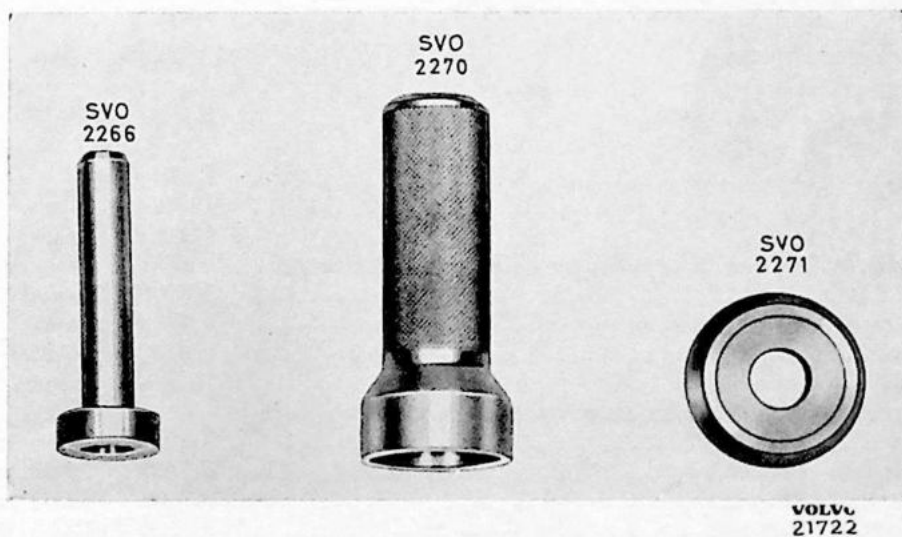


Fig. 87. Special tools for water pump.

SVO 2266 Drift for removing and fitting
pump shaft and impeller.
SVO 2270 Drift for fitting seal.

SVO 2271 Ring for removing and fitting
ball bearings.

Compression rings

Beveled on upper inner edge.	
Number on each piston	2
Height upper ring (chromed)	0.078" (1.97 mm)
lower ring	0.078" (1.97 mm)
Ring clearance in groove	0.0027"—0.0031" (0.068—0.079 mm)

Oil rings

Number on each piston	1
Height	0.186" (4.73 mm)
Ring clearance in groove	0.0017"—0.0029" (0.045—0.073 mm)

Piston pins

Fully floating. Circlips at both ends in piston.	
Fit in connecting rod	Close running fit
Fit in piston	Slide fit
Diameter, standard	0.748" (19 mm)
0.05 mm oversize	0.750" (19.05 mm)
0.10 mm ..	0.752" (19.10 mm)
0.20 mm ..	0.754" (19.20 mm)

Cylinder head

Height measured from cylinder head contact surface to cylinder head nut flats	3.90" (99 mm)
---	---------------

Crankshaft

Replaceable bearing shells for main and big-end bearings.	
Crankshaft end play	0.0004"—0.0040" (0.01—0.10 mm)
Main bearings, radial play	0.0005"—0.0025" (0.014—0.064 mm)
Connecting rod bearings, radial play	0.0020"—0.0036" (0.051—0.091 mm)

Main bearings

Main bearing journals

Journal diameter, standard	2.1240"—2.1244" (53.950—53.960 mm)
0.010" undersize	2.1140"—2.1144" (53.696—53.706 mm)
0.020" ..	2.1040"—2.1044" (53.442—53.452 mm)
0.030" ..	2.0940"—2.0944" (53.188—53.198 mm)
0.040" ..	2.0840"—2.0844" (52.934—52.944 mm)
Journal width, flange bearing, standard	1.5329"—1.5344" (38.935—38.975 mm)
0.1 mm oversize (for 0.010" undersize shell)	1.5369"—1.5384" (39.035—39.075 mm)
0.2 mm ..	1.5407"—1.5423" (39.135—39.175 mm)
0.3 mm ..	1.5447"—1.5463" (39.235—39.275 mm)
0.4 mm ..	1.5486"—1.5502" (39.335—39.375 mm)

Main bearing shells

Thickness, standard	0.0752"—0.0755" (1.911—1.918 mm)
0.010" undersize	0.0802"—0.0805" (2.038—2.045 mm)
0.020"	0.0852"—0.0855" (2.165—2.172 mm)
0.030"	0.0902"—0.0905" (2.292—2.299 mm)
0.040"	0.0952"—0.0955" (2.419—2.426 mm)

Connecting rod bearings

Connecting rod bearing journals.

Bearing seat width	1.2953"—1.2992" (32.900—33.00 mm)
Journal diameter, standard	1.8736"—1.8740" (47.589—47.600 mm)
0.010" undersize	1.8635"—1.8640" (47.335—47.347 mm)
0.020"	1.8536"—1.8540" (47.081—47.092 mm)
0.030"	1.8436"—1.8440" (46.827—46.838 mm)
0.040"	1.8336"—1.8520" (46.573—46.584 mm)

Connecting rod bearing shells.

Thickness, standard	0.0614"—0.0617" (1.560—1.568 mm)
0.010" undersize	0.0664"—0.0667" (1.687—1.695 mm)
0.020"	0.0714"—0.0717" (1.814—1.822 mm)
0.030"	0.0764"—0.0767" (1.941—1.949 mm)
0.040"	0.0814"—0.0817" (2.068—2.076 mm)

Connecting rods

Marked 1—4 on side away from camshaft. Classified A—D showing weight classification. Only connecting rods with same weight classification may be used in the same engine. Axial play at crankshaft ..

Length, centre-centre	0.0060"—0.0140" (0.15—0.35 mm)
Weight, Class A	5.905 ± 0.004" (150 ± 0.1 mm)
B	20.39—21.44 oz. (578—608 grams)
C	21.44—22.50 oz. (608—638 grams)
D	22.50—23.56 oz. (638—668 grams)
	23.56—24.62 oz. (668—698 grams)

Flywheel

Permissible axial play	0.008" (0.20 mm)
Ring gear (chamfer facing forwards)	116 teeth

Flywheel housing

Permissible axial play for rear surface	0.0016" (0.08 mm)
Max. radial play for rear guide	0.0060" (0.15 mm)

Camshaft

Drive	Fiber gear on camshaft
Number of bearings	3
Forward bearing journal, diameter	1.8491"—1.8504" (46.975—47.000 mm)
Centre bearing journal, diameter	1.6919"—1.6929" (42.975—43.000 mm)
Rear bearing journal, diameter	1.4557"—1.4567" (36.975—37.000 mm)
Radial clearance	0.0010"—0.0029" (0.025—0.075 mm)
Valve clearance for check of camshaft setting (cold engine)	0.043" (1.1 mm)
Inlet valves should then open at	10° after T.D.C.

Camshaft bearings

Forward bearing, diameter	1.8514"—1.8524" (47.025—47.050 mm)
Centre bearing, diameter	1.6939"—1.6949" (43.025—43.050 mm)
Rear bearing, diameter	1.4577"—1.4587" (37.025—37.050 mm)

Timing gears

Crankshaft gear	20 teeth
Camshaft gear	40 teeth
Backlash	0.0004"—0.0016" (0.01—0.04 mm)

Valve system

Valves

Inlet

Disc diameter	1.46" (37 mm)
Stem diameter	0.3091"—0.3100" (7.859—7.874 mm)
Valve seat angle	44.5°
Cylinder head seat angle	45°
Seat width in cylinder head	0.060" (1.5 mm)

Exhaust

Disc diameter	1.34" (34 mm)
Stem diameter	0.3082"—0.3089" (7.830—7.845 mm)
Valve seat angle	44.5°
Cylinder head seat angle	45°
Seat width in cylinder head	0.060" (1.5 mm)

Valve clearances

Clearance, inlet, warm engine	0.016" (0.40 mm)
Clearance, exhaust, warm engine	0.018" (0.45 mm)

PV

Valve guides

Length	2.44" (62 mm)
Inner diameter	0.311"—0.312" (7.905—7.920 mm)
Length above cylinder head upper surface	0.83" (21 mm)
Clearance valve stem-valve guide, inlet valves	0.0012"—0.0024" (0.031—0.061 mm)
Clearance valve stem-valve guide, exhaust valves.	0.0024"—0.0035" (0.060—0.090 mm)

Valve springs

Springs close-wound at one end. This end should be turned downwards.

Length, unloaded	1.77" (45 mm)
in./loading, lb.	1.54/56 ± 4 ¹ / ₂
mm/loading, kg.	39/25.5 ± 2
in./loading, lb.	1.20/145 ± 8
mm/loading, kg.	30.5/66 ± 3.5

Lubricating system

Oil capacity of crankcase	4 ⁷ / ₈ Imp. pints = 5 ³ / ₄ US pints (2.75 liters)
Oil capacity, incl. oil cleaner	6 ¹ / ₄ Imp. pints = 7 ¹ / ₂ US pints (3.5 liters)
Oil pressure, warm engine (2000 r.p.m. = 30 m.p.h. 50 km.p.h. in top gear)	36—50 lb./sq.in. (2.5—3.5 kg/cm ²)
Lubricant	Engine oil (For Service MM, MS)
viscosity, below 32° F (0° C)	SAE 10W
from 32° F (0° C) to 90° F (30° C)	SAE 20
above 90° F (30° C)	SAE 30

Oil pump

Type	Gear pump
Number of teeth	10
Axial clearance	0.0008"—0.004" (0.020—0.10 mm)
Radial clearance	0"—0.004" (0.00—0.10 mm)
Backlash	0.006"—0.014" (0.15—0.35 mm)

Oil cleaner

Type	Full-flow
Make and designation	AC, Mann or Fram

Relief valve spring

Length unloaded	1.575" ± 0.002" (40 ± 0.5 mm)
loaded with 5 ¹ / ₂ ± 1 ¹ / ₂ lb. (2.5 ± 0.2 kg)	1.340" (34 mm)
8 ± 1 ¹ / ₂ lb. (3.5 ± 0.2 kg)	1.230" (31.5 mm)

Fuel system

Fuel pump, make and type	AC diaphragm pump
Fuel pressure	Min. 2 lb./sq.in. (0.14 kg/cm ²) Max. 3.5 lb./sq.in. (0.25 kg/cm ²)
Capacity at idling speed	$\frac{7}{8}$ Imp. pint/min.=1 US pint/min. (0.5 liters/min.)
Fuel gauge, type	Electric
Fuel tank capacity PV 444, 445, P 544	$7\frac{3}{4}$ Imp. gallons= $9\frac{1}{4}$ US gallons
121/122 S	10 Imp. gallons=12 US gallons

Carburettor (B 16 A)

Model designation	Zenith 34 VN	
	Designation	Dimensions
Venturi	27	
Main jet, standard	97	0.97 mm
ethyl fuel	102	1.02 mm
Compensation jet	97	0.97 mm
Idling jet	50	0.50 mm
Idling air jet	50	0.50 mm
Acceleration jet	40	0.40
Float valve	1.75	
Float valve washer, thickness		1.0 mm (0.040")
Fuel level during operation		18 mm (0.70") below float bowl surface approx. 400—600 r.p.m.
Idling speed (warm engine)		

Ignition system

Voltage.	6 V
Order of firing	1-3-4-2
Ignition setting when assembled, (83 octane Research Method)	2° after T.D.C.
(87—97 octane Research Method)	2°—4° before T.D.C.
Ignition setting, stroboscope setting 1500 engine r.p.m. with vacuum regulator disconnected (83 octane Research Method)	15° before T.D.C.
(87—97 octane Research Method)	19°—21° before T.D.C.
Spark plugs	Bosch W 175 T 3 AC 44 com Auto Lite A7 Champion J7 or corresponding
Spark plug gap	0.028"—0.032" (0.7—0.8 mm)

Distributor

Make and designation	Bosch V JU 4 BR 20
Direction of rotation	Clockwise
Contact breaker gap	0.016"—0.020" (0.4—0.5 mm)
Breaker arm tension	14—18 oz. (0.4—0.5 kg)
Dwell angle	50±3°

Cooling system

Type	Pressure
Filler cap valve opens at	3.2—4.2 lb./sq.in. (0.23—0.30 kg/cm ²)

PV

	Early prod.	Late prod.
Thermostat marked	165	170
Starts to open at	161°—163° F (72°—76° C)	167°—172° F (75°—78° C)
Fully open at	180°—188° F (83°—87° C)	194° F (90° C)
Fan belt, designation		HC .380"×33"

Table for anti-freeze:		Ethylene glycol	Water
Frost proof down to	14° F (—10° C)	2 qts. (2.0 lit.)	1½ galls. (6.5 lit.)
	5° F (—15° C)	2¼ qts. (2.5 lit.)	1¼ galls. (6.0 lit.)
	—4° F (—20° C)	3 qts. (3.0 lit.)	1⅛ galls. (5.5 lit.)
	—22° F (—30° C)	3¾ qts. (4.0 lit.)	1 gall. (4.5 lit.)
	—40° F (—40° C)	4 qts. (4.5 lit.)	⅞ gall. (4.0 lit.)

Wear tolerances

Cylinders

Rebore when worn (if oil consumption abnormal) 0.010" (0.25 mm)

Crankshaft

Maximum main bearing journal out-of-round 0.0020" (0.05 mm)
 Maximum connecting rod journal out-of-round 0.0028" (0.07 mm)
 Maximum crankshaft end play 0.0060" (0.15 mm)

Valves

Maximum valve stem to valve guide clearance 0.0060" (0.15 mm)
 Maximum valve stem wear 0.0008" (0.02 mm)

Camshaft

Maximum out-of-round (with new bearings) 0.0030" (0.075 mm)
 Maximum bearing wear 0.0008" (0.02 mm)

Timing gears

Permissible backlash 0.0050" (0.12 mm)

Tightening torques

	Lb.ft.	Kgm.
Cylinder head	50—60	7—8
Main bearings	60—70	8—10
Big-end bearings	30—35	4—5
Flywheel	17—20	2.3—2.7
Oil cleaner center bolt	36	5
Spark plugs, 14 mm	25	3.5
Generator bolts (⅜"—16)	18	2.5
Camshaft nut	105	15

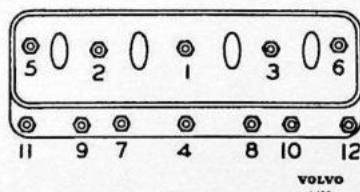
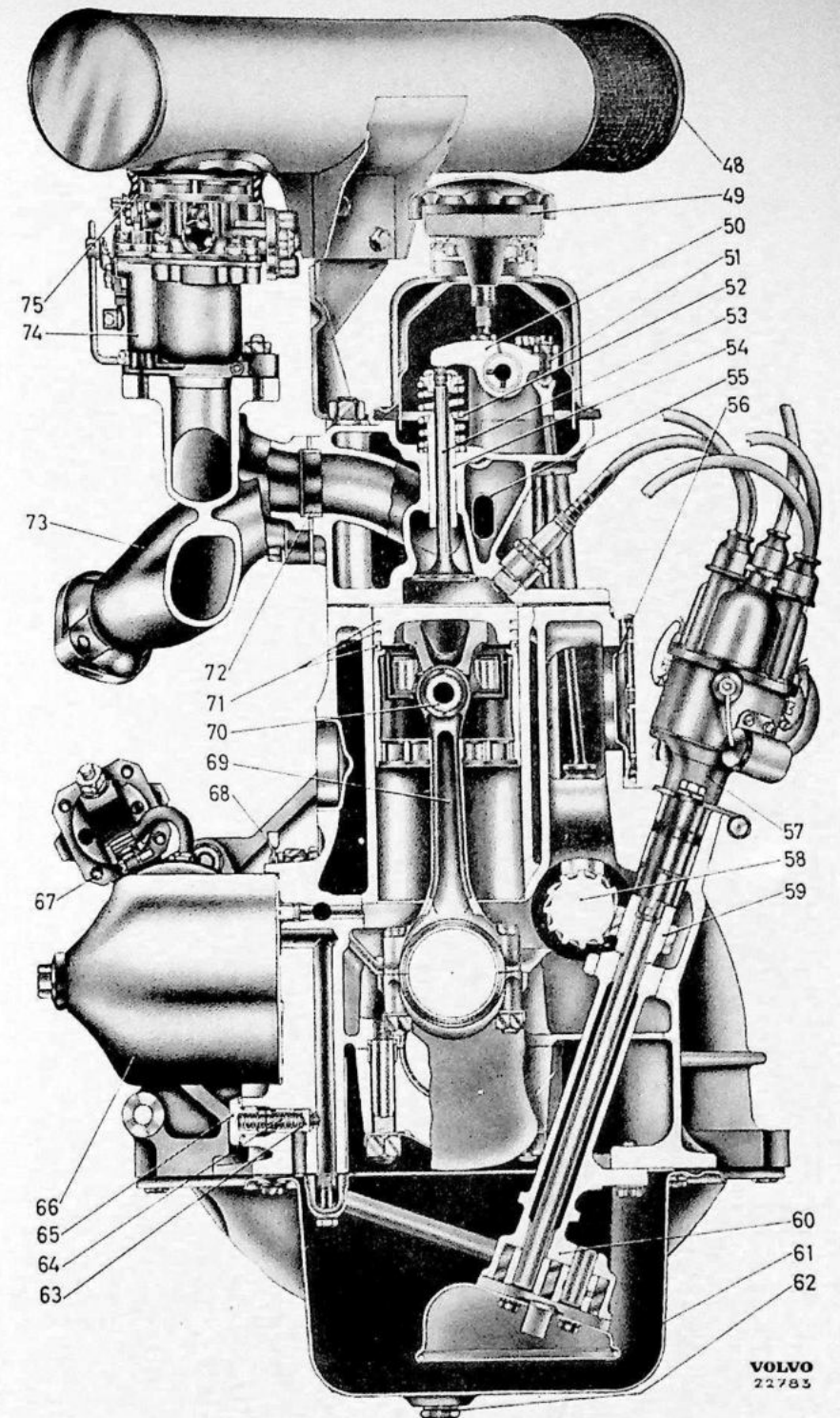
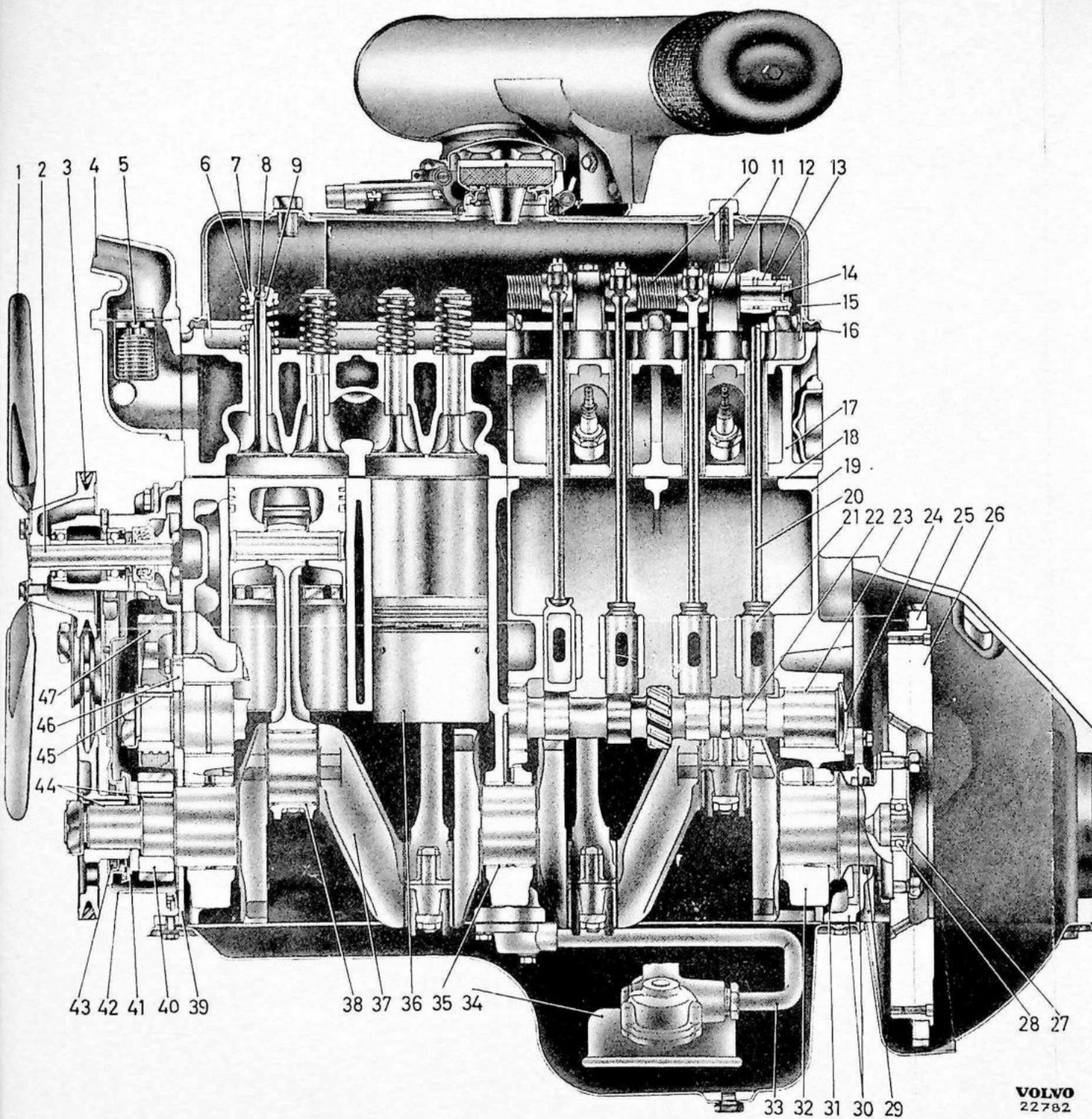


Fig. 88. Tightening sequence for cylinder head nuts.



Longitudinal and cross sections of B 16 A engine.

1. Fan
2. Water pump
3. Fan belt
4. Thermostat housing, upper part
5. Thermostat
6. Valve spring seat
7. Rubber ring
8. Valve
9. Valve retainer
10. Spring
11. Bearing bracket
12. Bushing
13. Rocker arm shaft

11. Seal washer
15. Rocker cover
16. Gasket
17. Cylinder head
18. Cylinder head gasket
19. Cylinder block
20. Push rod
21. Valve lifter
22. Camshaft
23. Bushing
24. Seal washer
25. Ring gear
26. Flywheel
27. Retainer

28. Ball bearing
29. Felt seal
30. Sealing flanges, upper and lower
31. Main bearing shell (flange bearing)
32. Bearing cap
33. Oil pipe
34. Oil pump
35. Main bearing shell
36. Piston
37. Crankshaft
38. Connecting rod bearing shell

39. Seal plate
40. Crankshaft gear
41. Oil slinger ring
42. Timing gear casing
43. Felt seal
44. Key
45. Key
46. Guide flange
47. Camshaft gear
48. Air cleaner (right-hand illustration)
49. Cap with breather
50. Rocker arm
51. Setscrew with lock nut

52. Valve spring
53. Valve
54. Valve guide
55. Water distribution pipe
56. Inspection cover
57. Distributor
58. Camshaft gear
59. Pump gear
60. Oil pump
61. Oil pan
62. Drain plug
63. Relief valve plunger
64. Relief valve spring

65. Nut and washer for relief valve
66. Oil cleaner
67. Starter motor solenoid
68. Water drain cock
69. Connecting rod
70. Piston pin
71. Piston rings
72. Guide sleeve
73. Exhaust manifold
74. Carburetor
75. Rubber gasket

VOLVO
22782

VOLVO
22783