

SERVICE MANUAL

CARS AND VANS

P 1200, PV 544

Part 5 a

REAR AXLE

(Spicer mod. 27)

Export Service Department

AKTIEBOLAGET

VOLVO

GÖTEBORG . SWEDEN

CONTENTS

Description	1
Repair instructions	2
Work that can be carried out with the rear axle fitted	2
Removing	4
Disassembly	4
Inspection	6
Assembly	6
Fitting	11
Adjusting tooth contact	11
Fault tracing	14
Tools	15
Specifications	16

DESCRIPTION

The rear axle on the P 1200 and PV 544 is carried in two support arms. The support arms are provided with two rubber bushings in which the rear axle housing is flexibly mounted. In order to take up the rear axle torque there are two torque rods attached to the body and levers on the housing. A track bar prevents the body and rear axle from moving sideways in relation to each other. The principle of the rear axle suspension is shown in Illustration I and II. The design of the rear axle is shown in Illustration III.

The rear axle is of the hypoid type, that is to say the drive pinion lies below the center of the ring gear. This means that the level of the propeller shaft can be lower and also permits greater stresses on the teeth of the pinion and ring gear. Apart from the pressure exerted against each other by the teeth in a gear system, there is also a wiping motion between the teeth in a hypoid gear system. This is why extra demands are made on the adhesion of the oil used. For this reason a special type of lubricating oil called hypoid oil which has outstandingly good adhesion is used. The use of the wrong type of oil can cause extremely rapid wear of the gears.

The final drive assembly consists of the drive pinion, ring gear and differential gears. The gear backlash and differential case bearing tension

are adjusted by means of shims inside the differential case bearings.

The differential case with the ring gear is journaled in the drive pinion carrier and the rear axle housing by means of two taper roller bearings. The ring gear is attached to the differential case by means of bolts.

The differential gears themselves in the differential case consist of two pinion gears on a short shaft and two side gears in which the axle shafts are carried by means of internal splines. The differential gears are journaled so that they can rotate and permit the axle shafts to rotate at different speeds when the car is being driven round curves. There is a washer under each of the differential gears and the drive pinion is carried in taper roller bearings. The axial location of the drive pinion relative to the ring gear is adjusted by means of shims under the outer race of the rear pinion bearing. The pinion bearings are adjusted by means of shims under the inner race of the front pinion bearing.

The outer end of each axle shaft is journaled in a taper roller bearing. Bearing clearance is adjusted by means of shims under the brake backing plates. Inside each of the axle shaft bearings there is an oil seal which, together with a felt ring outside each bearing, prevents oil from seeping out from the final drive onto the brake linings.

REPAIR INSTRUCTIONS

Work that can be carried out with the rear axle fitted

Replacement of axle shaft oil seal

1. Remove the wheel and pull off the wheel hub, Fig. 1. Use puller SVO 1791. Remove the brake backing plate after having placed a wooden block under the brake pedal and loosened the brake line from the backing plate.
2. Pull out the axle shaft, Fig. 2. Use puller SVO 2204.
3. Pull out the oil seal by using tool SVO 4078, Fig. 3.
4. Drive in the new oil seal. Make sure it is correctly located. Use tools SVO 1801 and SVO 1803, Fig. 4.
5. Remove any oil and grease there may be on the brake backing plate. Replace brake linings if any oil or grease has come under them.
6. Fit the axle shaft and brake backing plate with a new felt washer.
7. Check the axle shaft end play. See the instructions under the heading "Assembly".
8. Replace the cross key if it has been removed and then fit the hub and wheel.

9. Air-vent the brake lines and adjust the rear wheel brakes. Follow the instructions given in Part. 7.
10. Check the oil level in the rear axle.

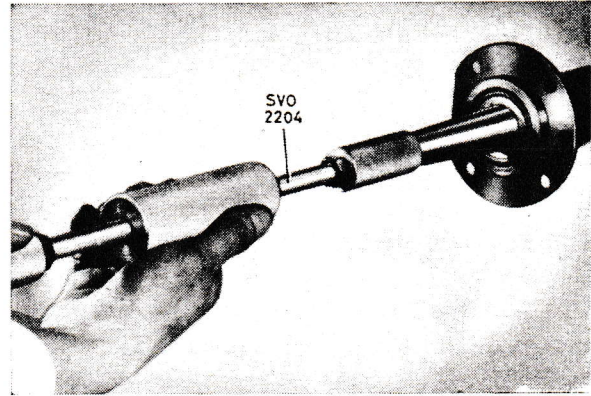

Fig. 2. Removing an axle shaft.

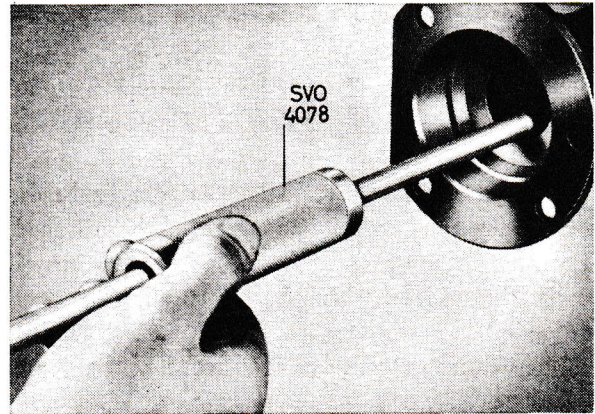

Fig. 3. Removing an oil seal.

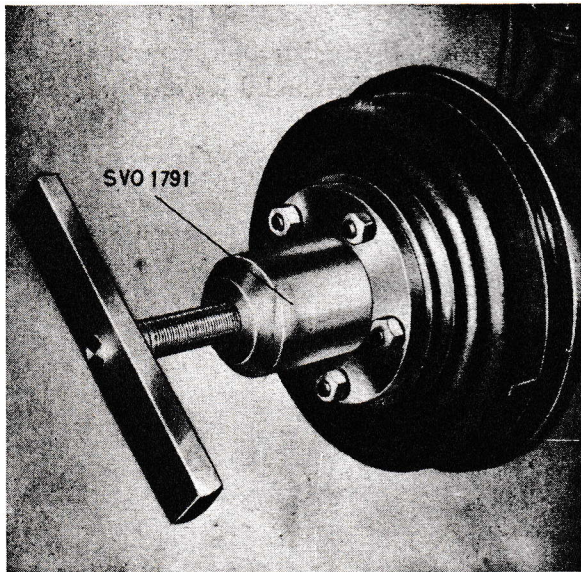

Fig. 1. Removing a wheel hub.

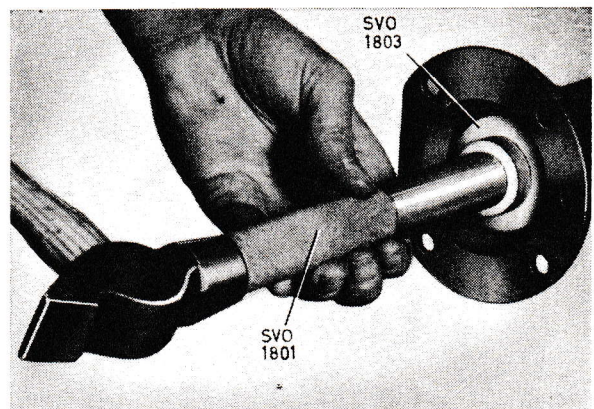

Fig. 4. Fitting an oil seal.

Replacing the drive pinion oil seal

1. Disconnect the rear section of the propeller shaft from the flange on the drive pinion. Check the looseness of the pinion in its bearing. If it is loose, this must be adjusted before fitting a new oil seal. See the instructions under the heading "Assembly".
2. Remove the flange nuts by using wrench SVO 2409 as rapport. Pull off the flange with tool SVO 2261 for PV 544 and SVO 2262 for P 1200, see Fig. 5. Remove the old oil seal with SVO 4030, Fig. 6.

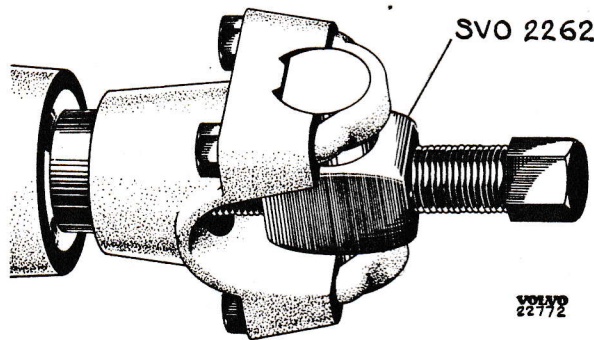

Fig. 5. Removing the flange.

3. Fit a new taper washer and fit the new oil seal with tool SVO 2403, Fig. 7.
4. Press on the flange with the help of press tool SVO 1845, Fig. 8.
5. Refit the propeller shaft.

Replacement of axle shaft and (or) bearing

1. Remove the wheel and pull off the hub, Fig. 1. Use puller SVO 1791. Remove the brake backing plate after having placed a wooden block under the brake pedal and disconnected the brake line from the backing plate.
2. Pull out the axle shaft, Fig. 2. Use tool SVO 2204. Check or replace the oil seal.
3. Press off the bearing, see Fig. 9. Use tool SVO 1806 under the bearing. Fit the new bearing by using tool SVO 1805.
4. Fit the axle shaft, shims, and brake backing plate.
5. Check the axle shaft end play and adjust if necessary. Follow the instructions under the heading "Assembly".

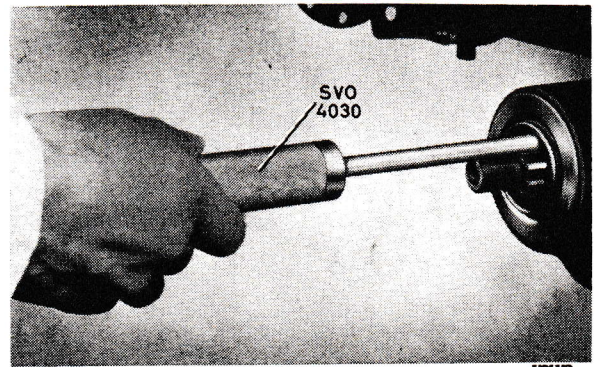

Fig. 6. Removing the oil seal.

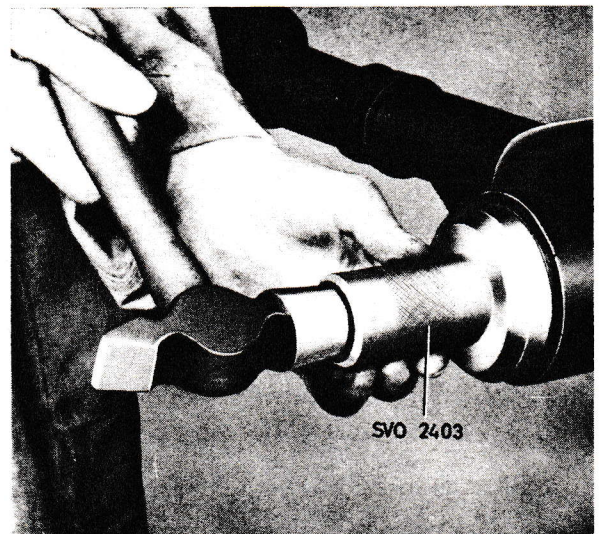

Fig. 7. Fitting the oil seal.

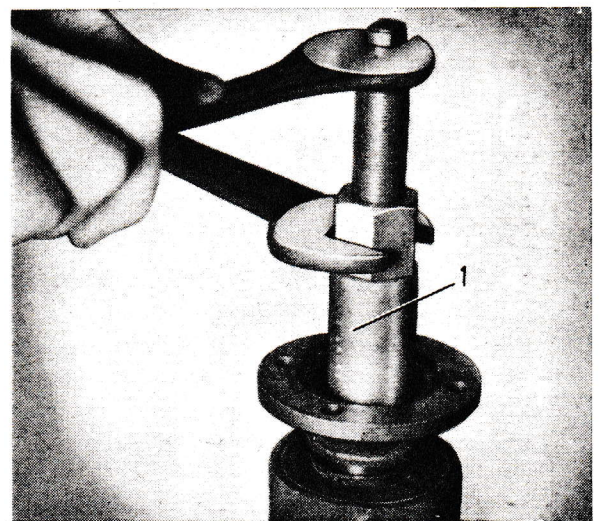

Fig. 8. Fitting the flange.

1. Press tool SVO 1845.

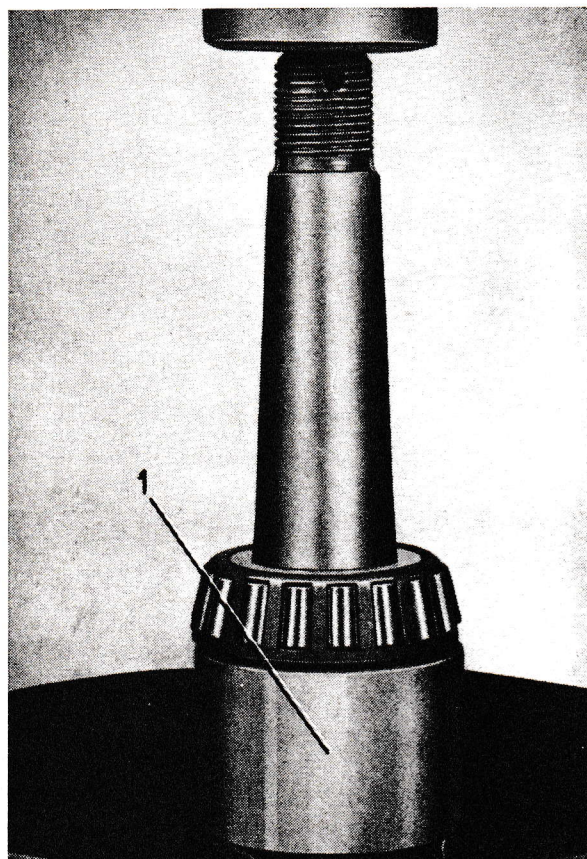

Fig. 9. Removing the axle shaft bearing.

1. Tool SVO 1806.

6. Fit the cross key, hub and wheel.
7. Air-vent the brake lines and adjust the brakes. Follow the instructions given in Part 7.
8. Check the oil level in the rear axle.

Removing

1. Remove the rear wheel nuts and the nuts from the axle shaft (13, Illustration III). Jack up the rear end of the car comparatively high by placing a jack under the rear axle. Fit blocks in front of the front wheels. Place supports under the body in front of the rear wheels. Take off the rear wheels.
2. Disconnect the rear propeller shaft from the flange (22) on the pinion (28) and disconnect the brake line from the master cylinder to the rear axle level with the rear universal joint (place a wooden block under the brake pedal).
3. Loosen the track bar, shock absorbers and shock absorber straps from the rear axle. Disconnect the hand brake cables at the adjuster.

4. Remove the lever nuts. Lower the rear axle and remove the springs. Loosen the bolts for the torque rods and remove the rear axle.
5. Clean the rear axle externally and drain off the oil.

Disassembly

Before disassembling the rear axle measure up the axle shaft end play and the ring gear backlash since this enables any fault to be located and remedied.

1. Place the rear axle in a fixture or on a couple of supports of a suitable height. Remove the rear wheel hubs with puller SVO 1791, see Fig. 1.
2. Disconnect the brake lines on the axle from the brake backing plates from the rear axle housing. Do not lose the shims.
3. Remove the axle shafts (13). Use puller SVO 2204, see Fig. 2. If necessary, press out the roller bearing (15) from the shaft. Use tool SVO 1806 as a support, see Fig. 9.
4. Remove the oil seals (14) with the help of puller SVO 4078, see Fig. 3.
5. Remove the inspection cover from the rear axle housing.
6. Check the aligning marks on the cap (2) and the housing (21), see Fig. 10. If there are no markings or the markings are not easy to see, mark one side with a punch. Remove the cap.

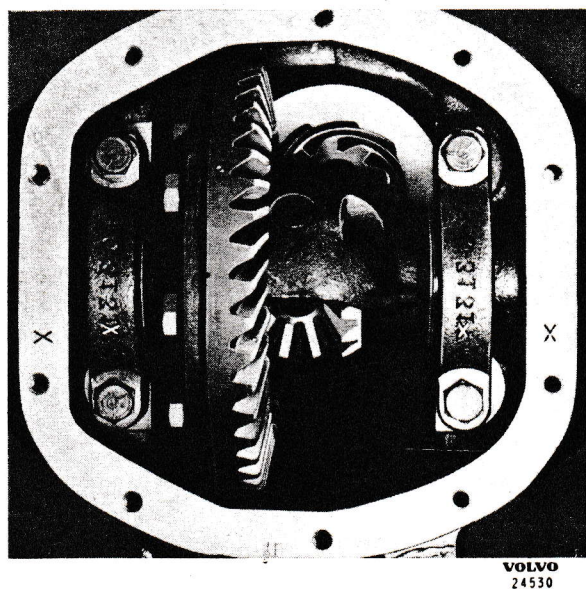

Fig. 10. Alignment markings on cap and housing.

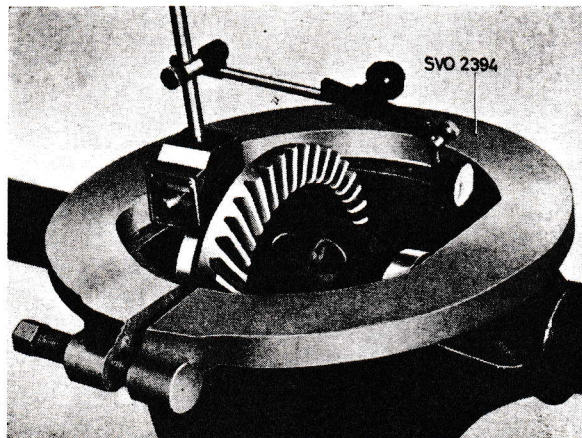

Fig. 11. Expanding the drive pinion carrier.

7. Fit tool SVO 2394 in the holes in the drive pinion carrier as shown in Fig. 11. Fit an indicator so that the expansion of the drive pinion carrier can be read off. Tighten the tensioning screw so that the carrier is expanded not more than 0.3 mm (0.012"). Remove the indicator. Lift out the differential case with the ring gear.
8. Remove the nut for the flange (22). Use tool SVO 2409 as rapport. Pull off the flange with puller SVO 2262, see Fig. 5. Press off the pinion (28).
9. Remove the oil seal (25) by using SVO 4030, see Fig. 6. Then remove the slinger (24) and the forward pinion bearing (27).
10. If necessary, drive out the bearing outer races, see Fig. 12. Use the standard handle SVO 1801 and tool SVO 4063 for the forward and SVO 4064 for the rear race. Do not lose the shims (30) under the rear ring.

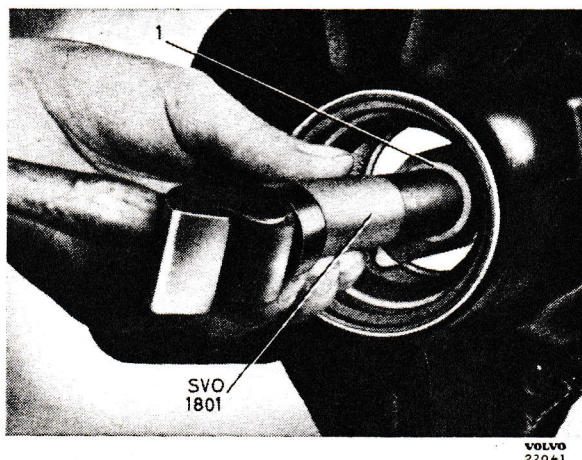

Fig. 12. Removing the bearing race.

1. Drift, see text.

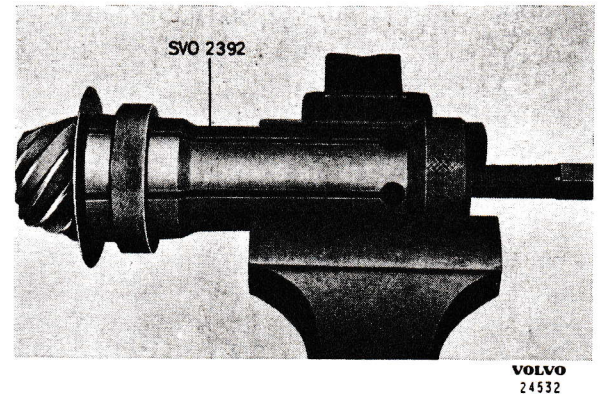

Fig. 13. Removing the rear pinion bearing.

11. If necessary pull off the rear bearing (29) from the pinion (28) by using puller SVO 2392, see Fig. 13. The puller is fitted in the following way: Slide the puller down over the rollers and press down the lock ring. Then tighten the puller with the screw until the rollers are against both the edge on the inner race and the edge on the puller. Strike the lock ring with a hammer.

Disassembling the differential assembly

1. Loosen the bolts and remove the ring gear (9).
2. Drive out the lock pin (7), see Fig. 14 and then the shaft (10) for the differential gear.

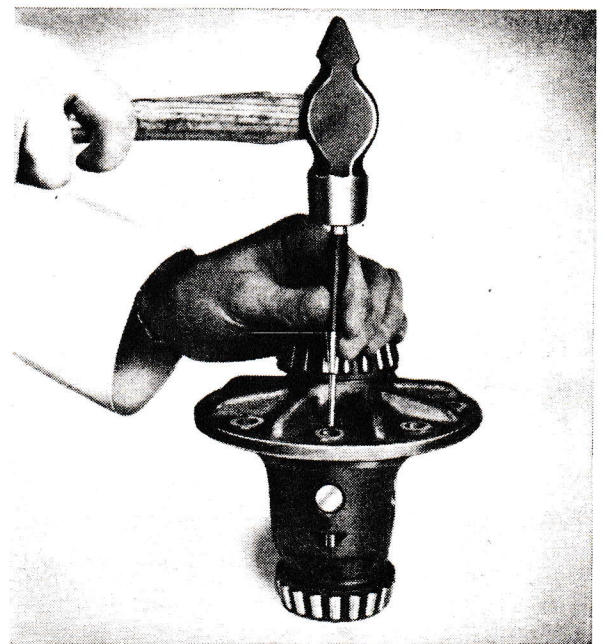

Fig. 14. Removing the lock pin.

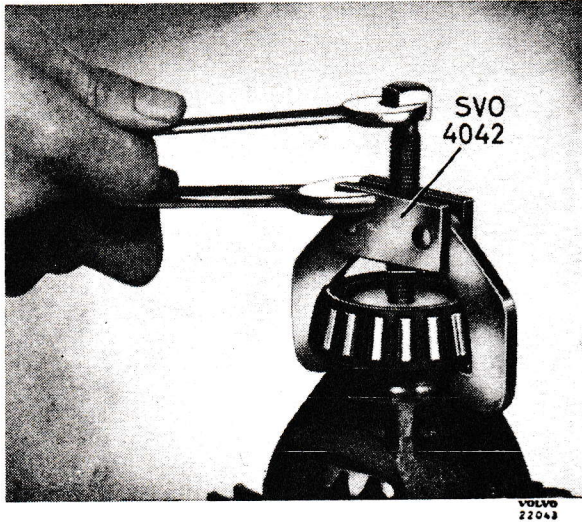

Fig. 15. Disassembling the differential case bearings.

Take out the thrust block (12), the differential gears (6, 8) and the thrust washers (5, 11).

3. Pull off the differential case bearings (1) with puller SVO 4042, see Fig. 15. Do not lose the shims (3).

Inspection

The various component parts must be first thoroughly cleaned before they are inspected. Make a close examination of all bearing races and bearings. There should be no rough spots or damage on the races, rollers, or cages. Replace any damaged bearings and races. Make a close examination of the drive pinion and the ring gear to ensure that there is no damage on the teeth. Cracked teeth can cause small pieces to loosen while the car is being driven. These small pieces can then fall between the gears and cause extremely serious damage in the rear axle. If there is any damage or any cracks in the pinion or ring gear, both should be replaced. The reason for this is that the drive pinion and ring gear are only sold in pairs since they have been run in together in special machines to ensure the correct tooth contact and quiet operation.

The differential gears should also be examined for cracks and damage on the teeth. Fit the differential gears in a clean and dry condition in the differential case together with the shaft and thrust washers. This makes it very easy to detect looseness and wear. If there is looseness the parts concerned should be replaced. There should be no unevenness on the thrust washers.

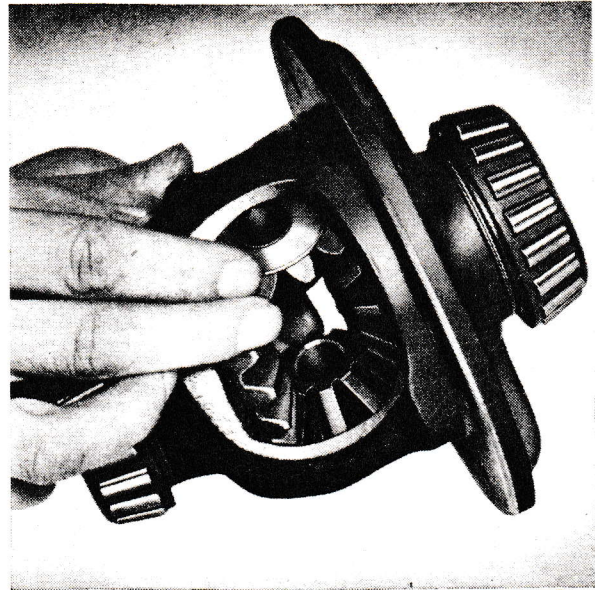

Fig. 16. Assembling the differential gears.

Check to ensure that the cylindrical part of the flange in contact with the oil seal is not worn or scored. If this is the case, replace the flange and the oil seal.

Inspect the axle shafts. Distorted or otherwise damaged axle shafts should be replaced.

Examine the oil seals and replace them if they are damaged or worn.

Make sure that the rear axle housing is free from cracks. Check that the brackets for the support arms and track bar are in good condition.

Assembly

Assembling the differential unit

1. Place the differential side gears (6) with their thrust washer (5) in the differential case (4). Then "roll" in both the differential pinion gears (8) together with the domed thrust washers (11) (both gears at the same time), see Fig. 16.
2. Fit the thrust block (12) and drive in the shaft (10).
3. Check the differential unit. If there is any looseness, fit new thrust washers. The flat thrust washers (5) can be replaced with either oversize washers or spring thrust washers. Fit the spring thrust washers the right way round. The "back" should face the differential case, see Fig. 17. After checking and, if necessary, replacing the washers, fit the lock pin (7).

4. Fit the ring gear (9). Make sure that the contact surfaces are clean and free from burr.

Tighten the bolts to a torque of 5.5—7 kgm (40—50 lb.ft).

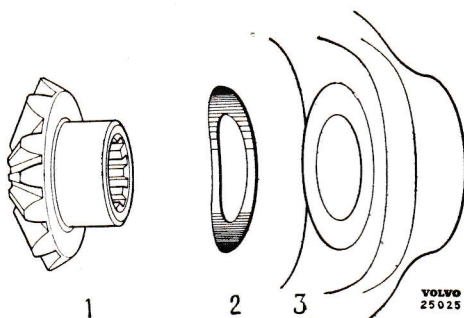

Fig. 17. Fitting spring thrust washers.

1. Differential gear.
2. Thrust washer.
3. Differential case.



Fig. 18. Fitting the differential case bearings.

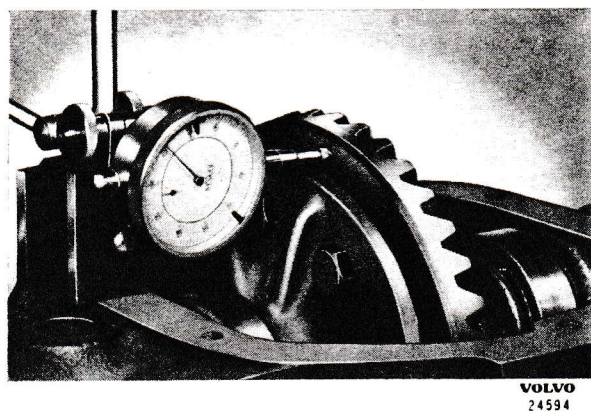

Fig. 19. Measuring the differential end play.

Assembling the final drive

1. Press on the differential case bearings (1) without shims. Use tool SVO 4112, see Fig. 18. Place the differential case with the ring gear and roller bearings in the housing. Measure the end play. The end play can be measured in two ways, either with a dial indicator or a feeler gauge. Whichever method is used, measurement must be carried out with a great deal of accuracy if a good result is to be obtained.

If a dial indicator is used, it is placed against the reverse side of the ring gear, see Fig. 19. The differential (remember this also includes the bearing outer races) is slid first one way and then the dial indicator is set to zero. Then the differential is slid the other way and the end play read off. If the feeler gauge system is to be used, use two gauges which are pushed down between one of the outer races and the bearing recess in the differential case. Add 0.2 mm (0.008") to the measurement obtained this showing the total thickness of the shims to be used when assembly is carried out.

2. Fit the oil slinger washer (31) on the pinion

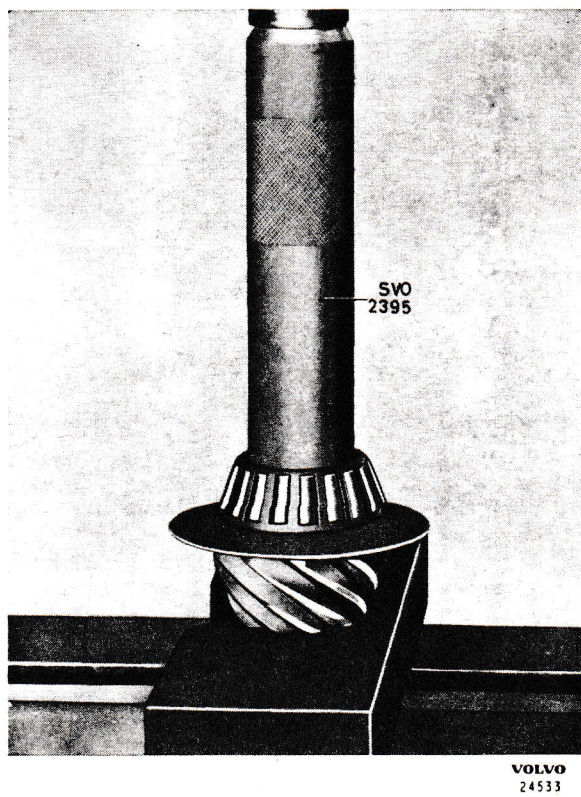

Fig. 20. Fitting the rear pinion bearing.

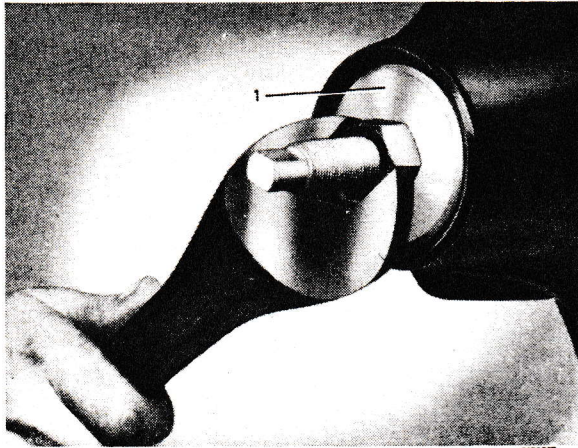

Fig. 21. Fitting the bearing races.

1. Press tool SVO 4047.

(28). Press on the rear bearing (29) with tool SVO 2395, see Fig. 20.

3. Replace the number of shims (30) for the rear pinion bearing outer race which were there before disassembly in the casing and then press in the outer races with the help of tool SVO 4047, see Fig. 21.
4. Place the pinion in the casing and fit the same number of shims (26) which were there when disassembling and then fit the forward pinion bearing (27). Fit the wrench SVO 2404 and the press tool SVO 1845 on

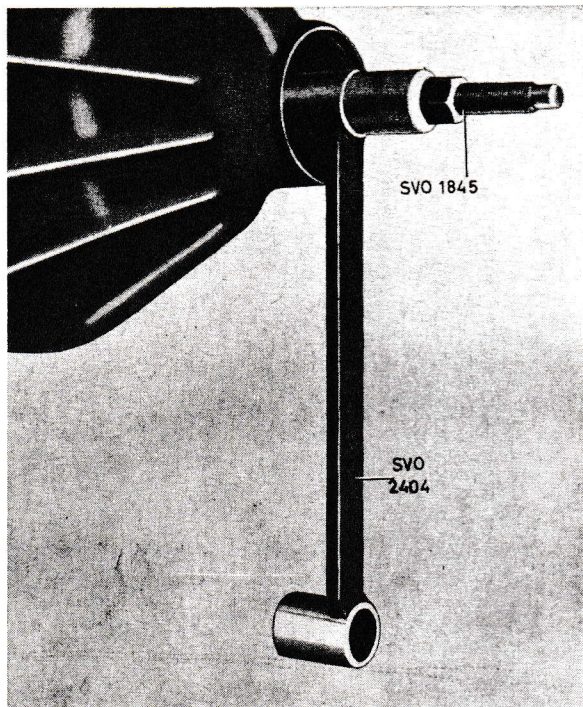

Fig. 22. Fitting the pinion.

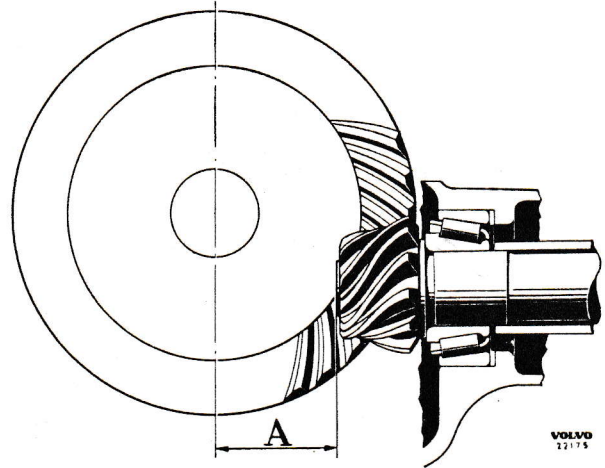

Fig. 23. Pinion location.

A. Nominal measurement = 2.094".

the front end of the pinion and tighten in the pinion, see Fig. 22.

5. Replace the press tool SVO 1845 with a washer and nut. Tighten the nut to a torque of 28—30 kgm. (200—220 lb.ft.). Then check the pinion bearing tension. It should be relatively easy to rotate the pinion (11.5—23 kgcm = 10—20 lb.in.). There should be no looseness. Bearing tension is adjusted by means of shims (26) on the forward pinion bearing.
6. There should be a certain nominal measurement (A, Fig. 23) to the centre line of the ring gear. Due to tolerance in manufacture, however, there are deviations from this nominal measurement. This deviation is shown on the ground surface on the pinion by means of a figure with a plus or minus sign. If there is a plus sign in front of the figure, the nominal measurement is to be increased and in the case of a minus sign, the nominal measurement is to be decreased.

The figure shown on the drive pinion is in thousandths of an inch.

To check the location of the pinion, use a dial indicator, indicator retainer SVO 2284 and the measuring tool SVO 2393 which consists of two parts: a pinion gauge and an adjuster fixture. Checking is carried out in the following way:

Place the pinion gauge on the ground end surface of the pinion and place the adjuster fixture in the differential bearing recesses as shown at II Fig. 24. Place the indicator

retainer on the dry pinion carrier and zero the indicator against the adjuster fixture, Fig 25.

Then move over the indicator retainer so that the indicator is against the pinion gauge, see Fig. 26. If the pinion is marked zero the adjuster fixture and the pinion gauge should be at the same height. If it is marked — then the pinion gauge should be higher than the adjuster fixture and if it is marked + the pinion gauge should be lower than the adjuster fixture when adjustment is correct. Correction is carried out by adding or removing shims under the rear pinion bearing outer race. If the pinion bearing had the correct tension just as many shims must be added or removed from the forward pinion bearing.

Example: The pinion is marked +2. The pinion gauge should then be 0.002" under the adjuster fixture. Measurements show that the pinion gauge is 0.006" above the adjuster fixture. The pinion must then be lowered $0.006" + 0.002" = 0.008"$, so shims corresponding to this thickness (measured with a micrometer) are to be removed from under the rear pinion bearing outer race.

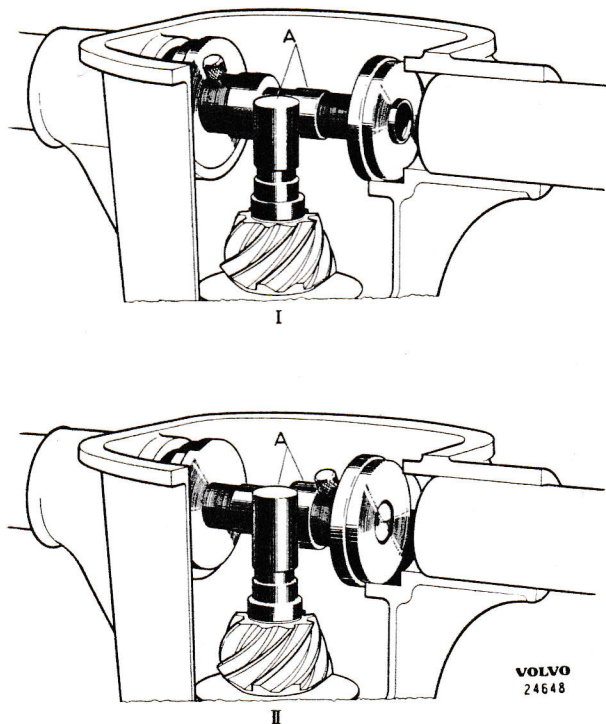

Fig. 24. Location of measuring tools.

- A. Measuring tool SVO 2393.
- I. Location, type Spicer mod. 23.
- II. Location, type Spicer mod. 27.

7. After adjusting the pinion location, check and adjust if necessary once again the pinion bearing tension.
8. Place the differential (without shims on the bearings) in the drive pinion carrier. Measure up the differential end play (the play between the pinion and the outer position of the differential). This can be measured either with an indicator against the reverse side of the ring gear or with two feeler gauges. Note the clearance obtained.
9. The clearance measured under point 8 above should be decreased by the backlash. Use here the average value of the backlash (0.003—0.006"). An example. The measured clearance according to point 1 = 0.055" plus tension 0.008" = 0.063". The measurement obtained according to point 8 above = 0.036".

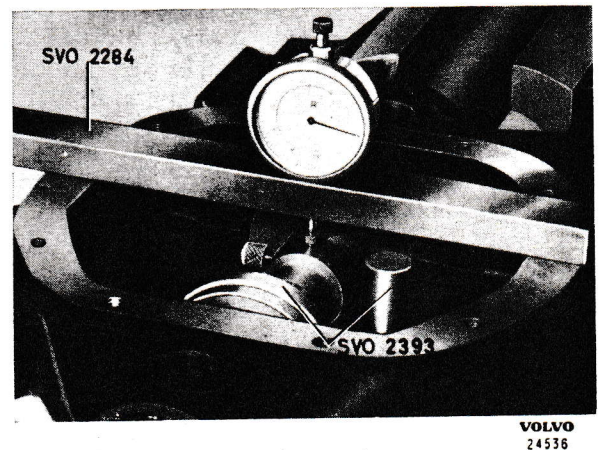

Fig. 25. Setting the indicator to zero.

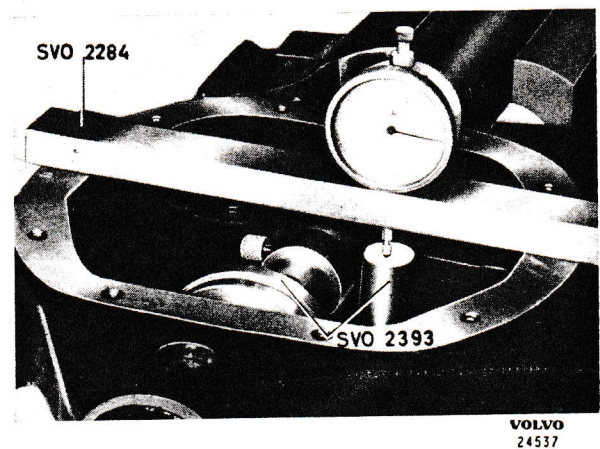

Fig. 26. Measuring the pinion location.

Thickness of shims on ring gear side= $0.036''-0.005''=0.031''$.

Thickness of shims on opposite side= $0.063''-0.031''=0.034''$.

10. Tighten the differential case bearings with puller SVO 4042. Fit shims according to the calculated values under the bearings and then press the bearings on again.
11. Fit tool SVO 2394, see Fig. 11 and an indicator on the drive pinion carrier. Tighten the tensioning screw so that the drive pinion carrier is expanded by not more than 0.3 mm (0.012"). Remove the indicator. Fit in the differential with bearings. Then remove the tool SVO 2394.
12. Fit the caps (2) with bolts and tighten the bolts to a torque of 5.5—7 kgm (40—50 lb.ft.). Fit an indicator against the reverse side of the ring gear, Fig. 27. Rotate the ring gear and measure its runout. This should not exceed 0.08 mm (0.003").

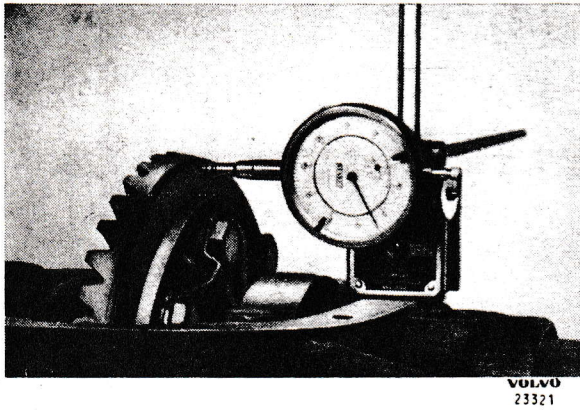

Fig. 27. Measuring the ring gear runout.

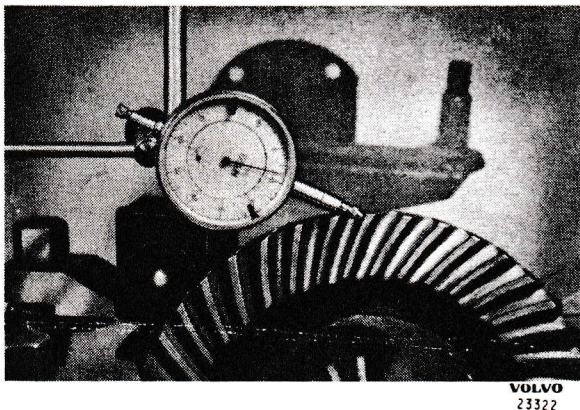

Fig. 28. Measuring the backlash.

13. Measure the backlash as shown in Fig. 28. This should 0.003—0.006".
14. Check the setting by marking the tooth contact as described under "Adjusting tooth contact".
15. When adjustment has been completed, remove the wrench SVO 2404.
16. Fit the oil slinger (24), the oil seal (25) and the paper washer. Use tool SVO 2403 for the oil seal. Then press on the flange (22) with the help of SVO 1845, see Fig. 8. Fit the washer and nut. Tighten the nut to a torque of 28—30 kgm (200—220 lb.ft.).
17. Fit the inspection cover and gasket.

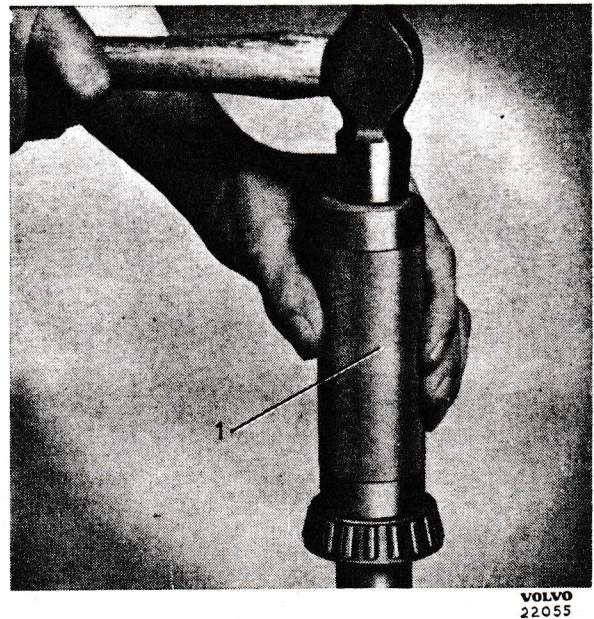

Fig. 29. Fitting the axle shaft bearings.

1. Tool SVO 1805.

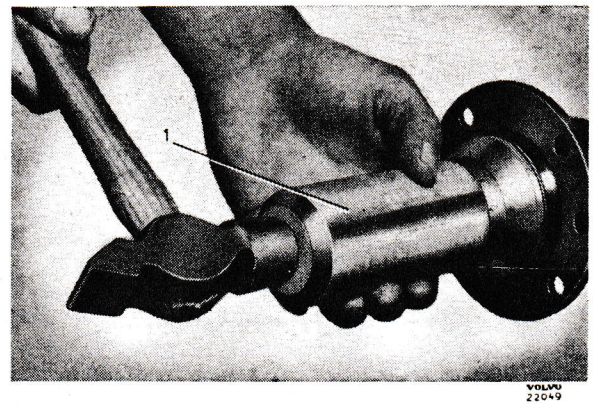

Fig. 30. Fitting the bearing race.

1. Tool SVO 2205.

Assembling the rear axle

1. Drive in the oil seals (14) for the axle shaft (13) with tool SVO 1803, see Fig. 4.
2. Drive the bearings (15) onto the axle shafts if they have been removed. Use tool SVO 1805, see Fig. 29.

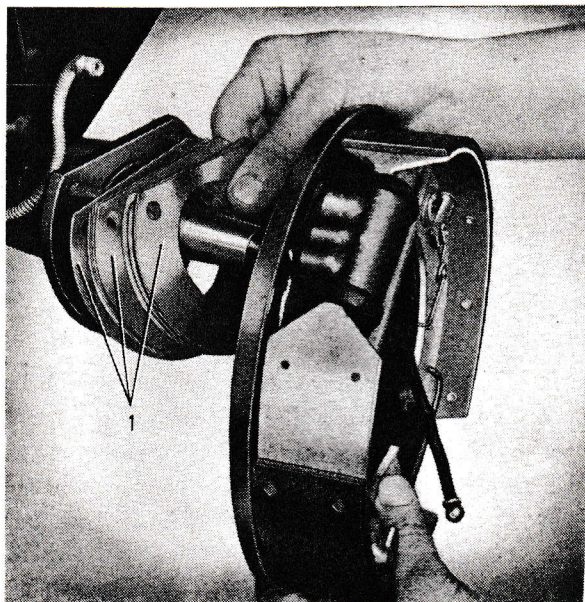

Fig. 31. Fitting the brake backing plate.

1. Shims.

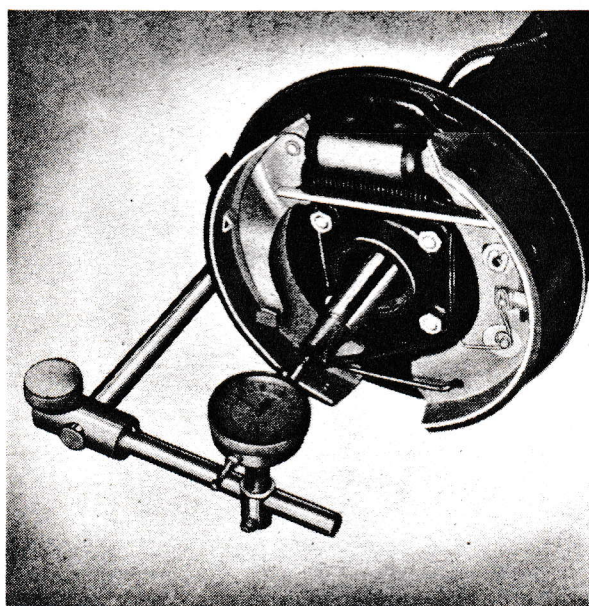

Fig. 32. Measuring the axle shaft end play.

3. Pack in the bearings with heat-resistant grease. Fit the axle shaft in the rear axle housing. Drive in the bearing outer races with tool SVO 2205, see Fig. 30.
4. Fit the brake backing plates and the shims (16) as well as the retainer and felt seal (18), see Fig. 31.
Check the axle shaft end play, see Fig. 32 and adjust if necessary. The end play should be 0.07—0.20 mm (0.003—0.008").
5. Fit the brake lines, the hubs and brake drums.

Fitting

1. Lift up the rear axle and fit the torque rods. Slide the support arms into the retainers on the body and fit the rubber blocks, washers and nuts. Tighten the nuts a couple of turns to start with.
2. Fit the springs, retainers and rubber blocks in position. Lift up the rear axle with a jack. Tighten the support arm nuts. Fit the shock absorbers, shock absorber straps and track bar.
3. Connect up the universal joint at the flange. Connect up the brake fluid hoses. Connect up the hand brake cables. Air-vent the brakes and adjust the hand brake. Fill up with oil.
Use only hypoid oil.
4. Fit the wheels and wheel nuts. Lower the car and tighten the wheel nuts.

Adjusting tooth contact

When the rear axle is assembled it is extremely important to ensure that the ring gear and drive pinion are correctly fitted relative to each other. This does not concern only the clearance between the teeth but also the tooth contact. When the tooth contact is correct, the stresses to which the teeth are subjected when the car is driven are distributed over the greater part of the teeth surfaces. In this way tooth breakage is avoided as well as abnormally rapid wear of the gears. A further advantage is that the gears operate more quietly. The instructions given below can be used as a guide while this work is being carried out.

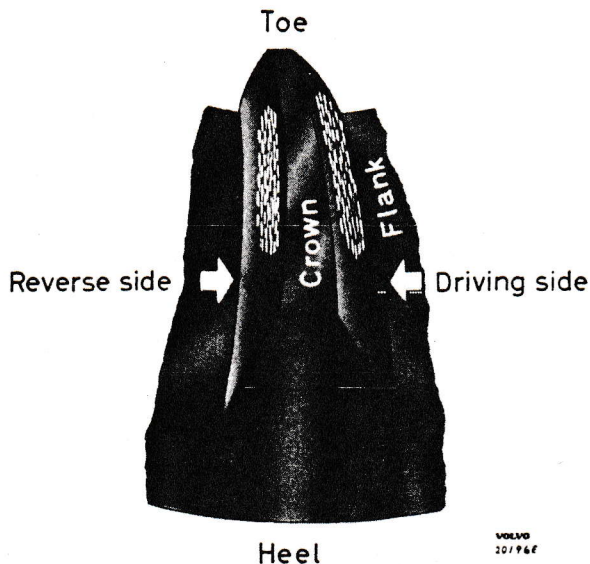

Fig. 33. Correct tooth contact pattern.

In order to describe tooth contact in a simple way the various parts of the gear teeth have been given special names. See Fig. 33 which shows one of the teeth on the ring gear. NOTE. Adjustment is based on the contact obtained on the ring gear teeth.

The driving side is the side subject to pressure from the drive pinion when the car is driven forwards.

The reverse side is the side subject to pressure when the car is reversed as well as when the engine is being used to brake the car when it is driven forwards.

The narrow end of the tooth is called the toe while the broad end is called the heel. The toe lies nearest the centre while the heel is furthest out on the ring gear. In order to obtain a clear picture of tooth contact, the ring gear teeth are smeared on both sides with marking paint consisting of red lead mixed with engine oil. The marking paint must not be too thin since this can give a faulty result. All the teeth should be smeared with a thin coating of marking paint. The pinion is then rotated 10 to 12 times in both directions, at the same time as the ring gear is braked hard by using a wooden wedge or similar device. The marking paint on the ring gear teeth is thus removed where the pinion teeth contact them so that a clear picture of the tooth contact extent and position is obtained. The correct tooth contact pattern is shown in Fig. 33.

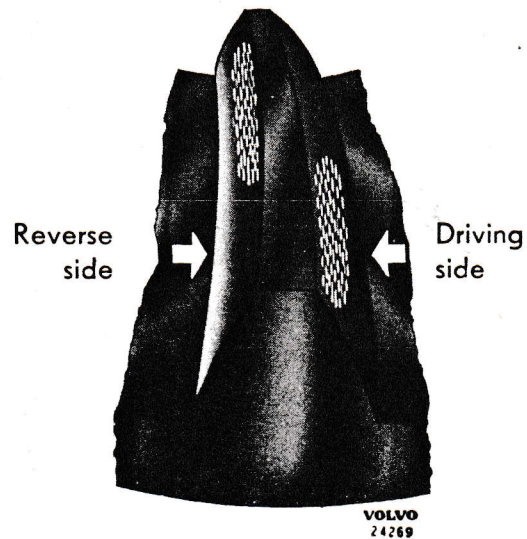

Fig. 34. Faulty tooth contact pattern.

NOTE. The tooth contact pattern is almost rectangular in shape and is half way up the tooth on the driving side but rather nearer the toe than the heel. On the reverse side the contact pattern is rather higher than on the driving side but otherwise similar.

Tooth contact adjustment is carried out by altering the position of the pinion relative to the ring gear by adding or removing shims at the rear pinion bearing outer race. At the same time, however, an equal number of shims of the same thickness must be added or removed at the forward bearing so that the pinion bearing tension is not altered.

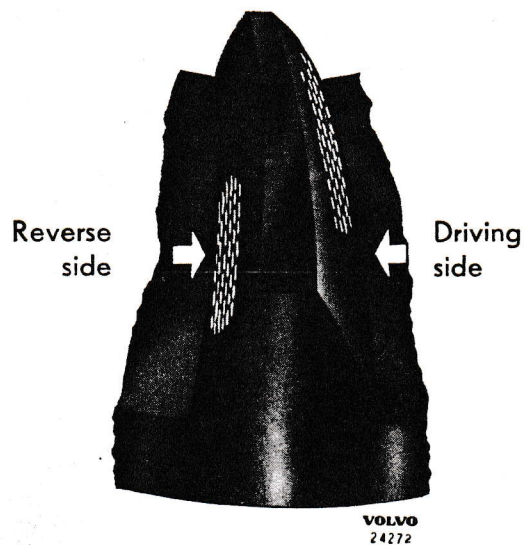

Fig. 35. Faulty tooth contact pattern.

Each time the position of the pinion is altered, the backlash must be adjusted and checked, see Fig. 28.

On a hypoid gear, the tooth contact pattern moves diagonally over the teeth and in a different direction on the driving and reverse sides.

If the pinion is moved inwards, the contact pattern on the driving side moves from a high position at the heel, Fig. 34, to a low position at the toe, Fig. 35. On the reverse side, the tooth contact pattern moves at the same time from a high position at the toe, Fig. 34, to a low position at the heel, Fig. 35.

This means that the tooth contact pattern on the driving side moves in the same direction as the pinion. If the contact pattern is too far out towards the heel the pinion is moved inwards

and if the contact pattern is too far out towards the toe, the pinion is moved outwards.

When you consider that the contact pattern is correct on the driving side, look at the contact pattern on the reverse side. If the adjustment is correct the contact pattern should be almost opposite each other.

The actual adjusting procedure is best carried out in the following way:

1. Adjust the backlash to the values shown in the specifications.
2. Smear the teeth with marking paint and rotate the pinion at the same time as the ring gear is braked.
3. Notice the position of the contact pattern and adjust as detailed above. Each time the position of the drive pinion is changed, check and adjust the backlash.

FAULT TRACING

The faults occurring in a rear axle become apparent as noisiness, overheating, leakage or axle shaft breakage. The noisiness usually encountered is a typical growling or whining sound.

FAULT	
REASON	REMEDY

Noisiness possibly accompanied by an abnormally high temperature

<p>Wrong type of oil used in rear axle.</p> <p>Oil level too low.</p> <p>Excessive bearing tension in final drive or on axle shaft.</p> <p>Faulty backlash.</p> <p>Faulty tooth contact.</p> <p>Worn bearings.</p> <p>Distorted rear axle housing.</p> <p>Twisted rear axle.</p>	<p>Drain off all the oil. Inspect the rear axle. Flush out the rear axle housing. Fill with hypoid oil. Top up with oil.</p> <p>Disassemble final drive (axle shaft) and re-adjust bearings.</p> <p>Disassemble final drive, adjust backlash and tooth contact in accordance with instructions.</p> <p>Disassemble final drive, replace worn bearings.</p> <p>Replace.</p> <p>Replace.</p>
----------------------------------------------------------------------------------------------------------------------------------------------------------------------------------------------------------------------------------------------------------------------------------	--------------------------------------------------------------------------------------------------------------------------------------------------------------------------------------------------------------------------------------------------------------------------------------------------------------------------------------------------------------------------------------------

Thumping sound in final drive when accelerating or decelerating

First ensure that the sound does not depend on worn universal joints.

<p># Worn shims on differential gears.</p> <p>Differential gears or differential shaft worn.</p> <p>One of drive gears loose on hub.</p> <p>Worn spline on shaft or in gears.</p>	<p>Fit new domed washers and oversize flat washers.</p> <p>Replace worn parts.</p> <p>Tighten loose nuts.</p> <p>Replace worn parts.</p>
-----------------------------------------------------------------------------------------------------------------------------------------------------------------------------------	------------------------------------------------------------------------------------------------------------------------------------------

Leakage

In case of leakage first check that the ventilation hole on the rear axle housing is not blocked.

<p>Leakage at axle shaft, (oil on brake linings).</p> <p>Leakage at the pinion.</p> <p>Leakage between rear axle housing and inspection cover.</p>	<p>Replace oil seal inside bearing and replace felt washer.</p> <p>Replace oil seal and paper washer.</p> <p>If necessary adjust pinion bearing tension or replace bearing.</p> <p>Check that the sealing surfaces are clean and smooth, replace the gasket.</p>
----------------------------------------------------------------------------------------------------------------------------------------------------	------------------------------------------------------------------------------------------------------------------------------------------------------------------------------------------------------------------------------------------------------------------

TOOLS

The following tools are required when carrying out repair work on the rear axle.

VOLVO
24538

Fig. 36. Special tools.

- | | | | |
|----------|---------------------------------------------------|----------|---------------------------------------------------------|
| SVO 1791 | Puller for wheel hubs. | SVO 2395 | Sleeve for assembly of rear pinion bearings. |
| SVO 1801 | Standard handle 18×200 mm. | SVO 2403 | Tool for fitting oil seal at flange. |
| SVO 1803 | Tool for fitting oil seals on axle shaft. | SVO 2404 | Tool for fitting forward pinion bearings. |
| SVO 1805 | Sleeve for fitting axle shaft bearings. | SVO 2409 | Rapport for flange. |
| SVO 1806 | Ring for disassembly of axle shaft bearings. | SVO 4030 | Puller for oil seal at flange. |
| SVO 1845 | Press tool for fitting flange. | SVO 4042 | Puller for differential case bearings. |
| SVO 2204 | Puller for axle shaft. | SVO 4047 | Tool for fitting pinion bearing outer races. |
| SVO 2205 | Sleeve for fitting axle shaft bearing outer race. | SVO 4054 | Dial indicator attachment. |
| SVO 2261 | Puller for flange PV 544. | SVO 4063 | Tool for disassembling front pinion bearing outer race. |
| SVO 2262 | Puller for flange, P 1200. | SVO 4064 | Tool for disassembling rear pinion bearing outer race. |
| SVO 2284 | Retainer for dial indicator. | SVO 4078 | Puller for oil seals on axle shaft. |
| SVO 2392 | Puller for rear pinion bearings. | SVO 4112 | Tool for assembly of differential case bearings. |
| SVO 2393 | Measuring tool for adjustment of pinion. | SVO 4148 | Retainer for dial indicators. |
| SVO 2394 | Expander tool for diassembly of differential. | | |

SPECIFICATIONS

Rear axle, type	Semi-floating
Track width	1315 mm (51 ⁴⁹ / ₆₄ ")
End play for axle shaft	0.07—0.20 mm (0.003—0.008")

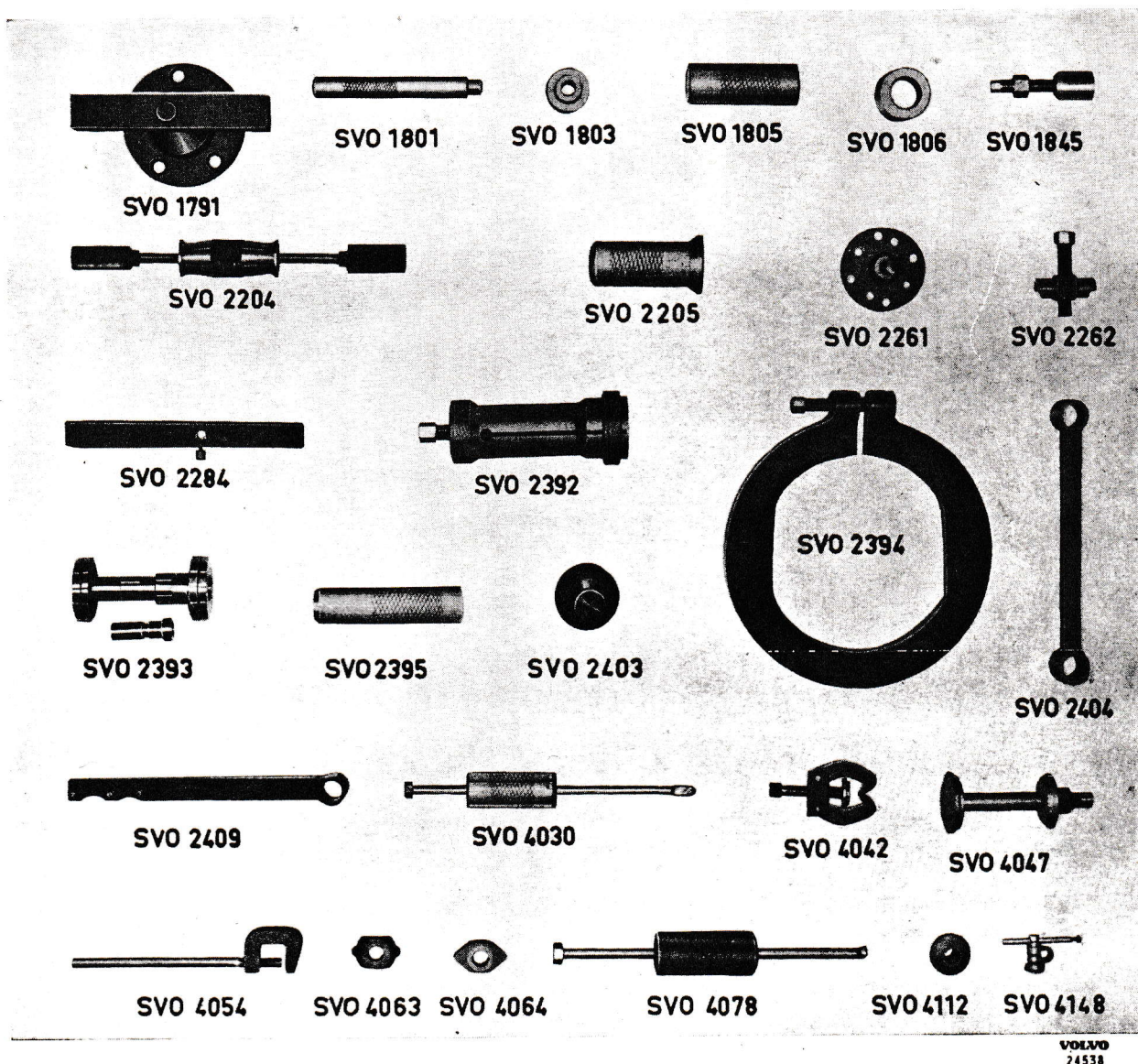
Final drive

Type	Spiral bevel (hypoid)
Ratio	4.56: 1 (⁹ / ₄₁) or 4.1: 1 (¹⁰ / ₄₁)
Runout, ring gear	max 0.003" (0.08 mm)
Backlash	0.003—0.006" (0.08—0.15 mm)
Pinion bearing tension	11.5—23 kgcm (10—20 lb.in.)
Lubricant	Hypoid oil
Lubricant viscosity	SAE 80
Oil capacity	1.3 litres (2 ¹ / ₄ Imp. pints = 2 ³ / ₄ US pints)

Tightening torques

	Kgm	lb.ft.
Flange	28—30	200—220
Caps	5.5—7	40—50
Ring gear	5.5—7	40—50

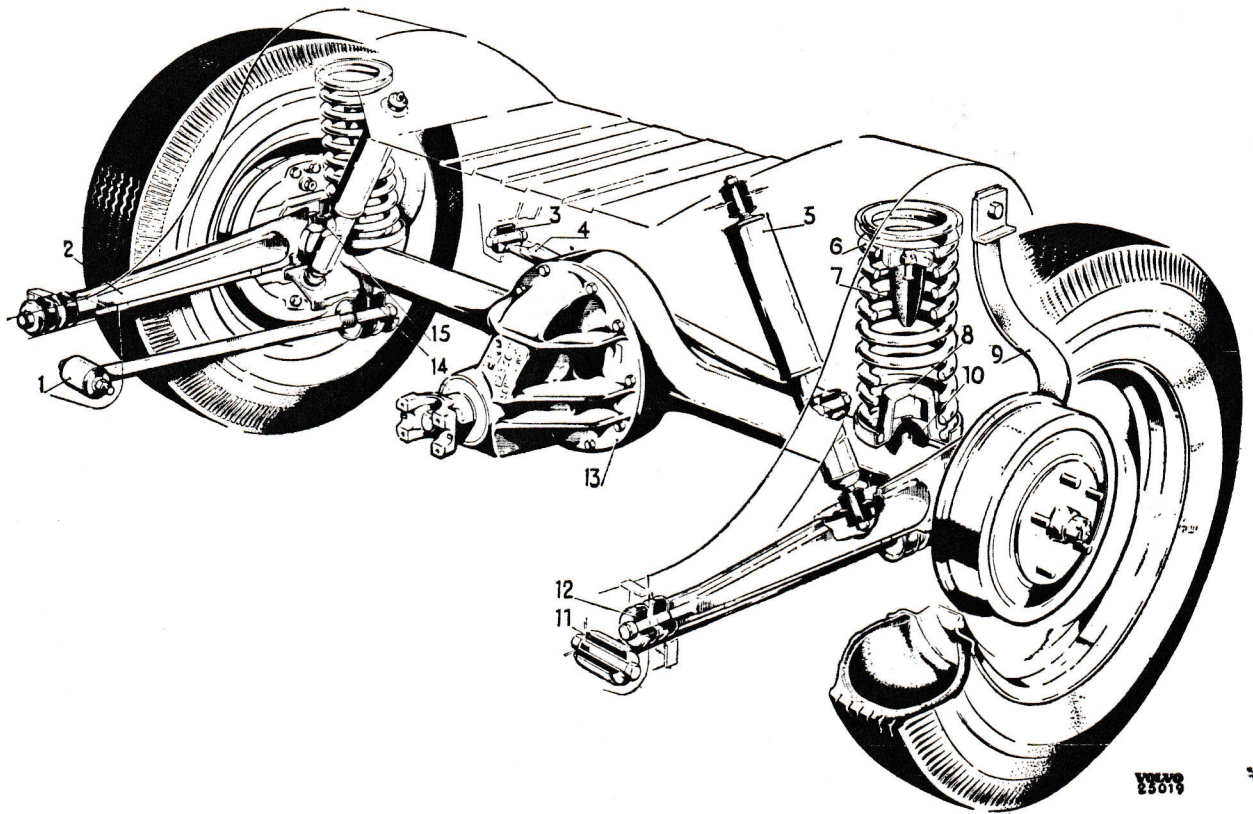

Illustration I. Rear suspension, P 1200

1. Torque rod.
2. Support arm.
3. Rubber bushing for track bar.
4. Track bar.
5. Shock absorber.
6. Spring.
7. Rubber block.
8. Spring retainer.
9. Shock absorber strap.
10. Rubber block.
11. Rubber bushing for torque rod.
12. Rubber bushing for support arm.
13. Rear axle.
14. Rubber bushing for torque rod.
15. Rubber bushing for support arm.

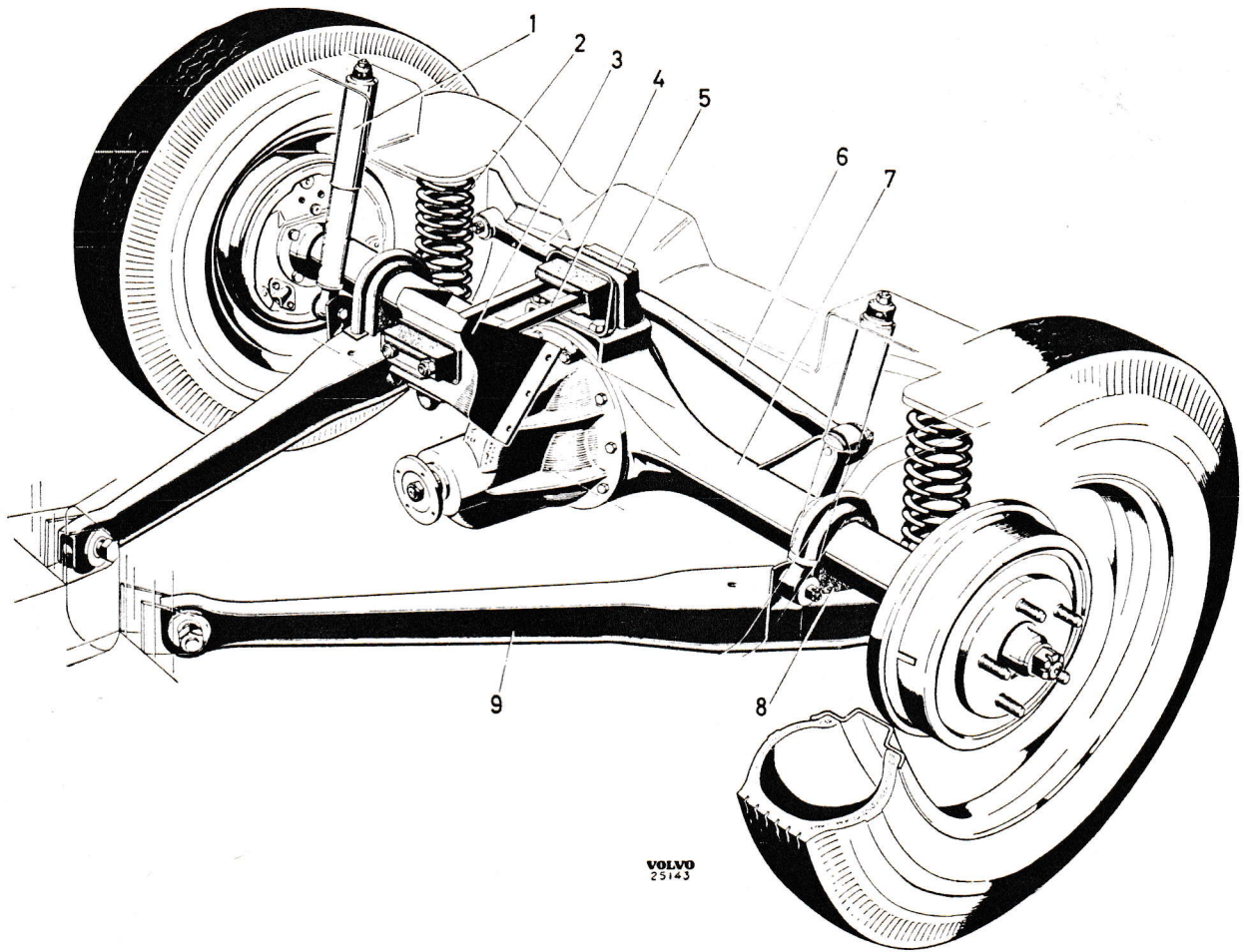

Illustration II. Rear suspension, PV 544

1. Shock absorber.
2. Spring.
3. Body attachment.
4. Torque rod.
5. Rubber block.
6. Track bar.
7. Rear axle.
8. Rubber bushing.
9. Support arm.

1. Differential case bearing.
2. Bearing cap.
3. Shims.
4. Differential case.
5. Thrust washer.
6. Differential side gear.
7. Lock pin.
8. Differential pinion gear.
9. Ring gear.
10. Shaft.
11. Thrust washer, domed.
12. Thrust block.
13. Axle shaft.
14. Oil seal.
15. Roller bearing.
16. Shims.
17. Brake backing plate.
18. Retainer with felt seal.
19. Brake drum.
20. Cross key.
21. Rear axle housing.
22. Flange.
23. Dust cover plate.
24. Oil slinger.
25. Oil seal.
26. Shims.
27. Forward pinion bearing.
28. Pinion.
29. Rear pinion bearing.
30. Shims.
31. Oil slinger.

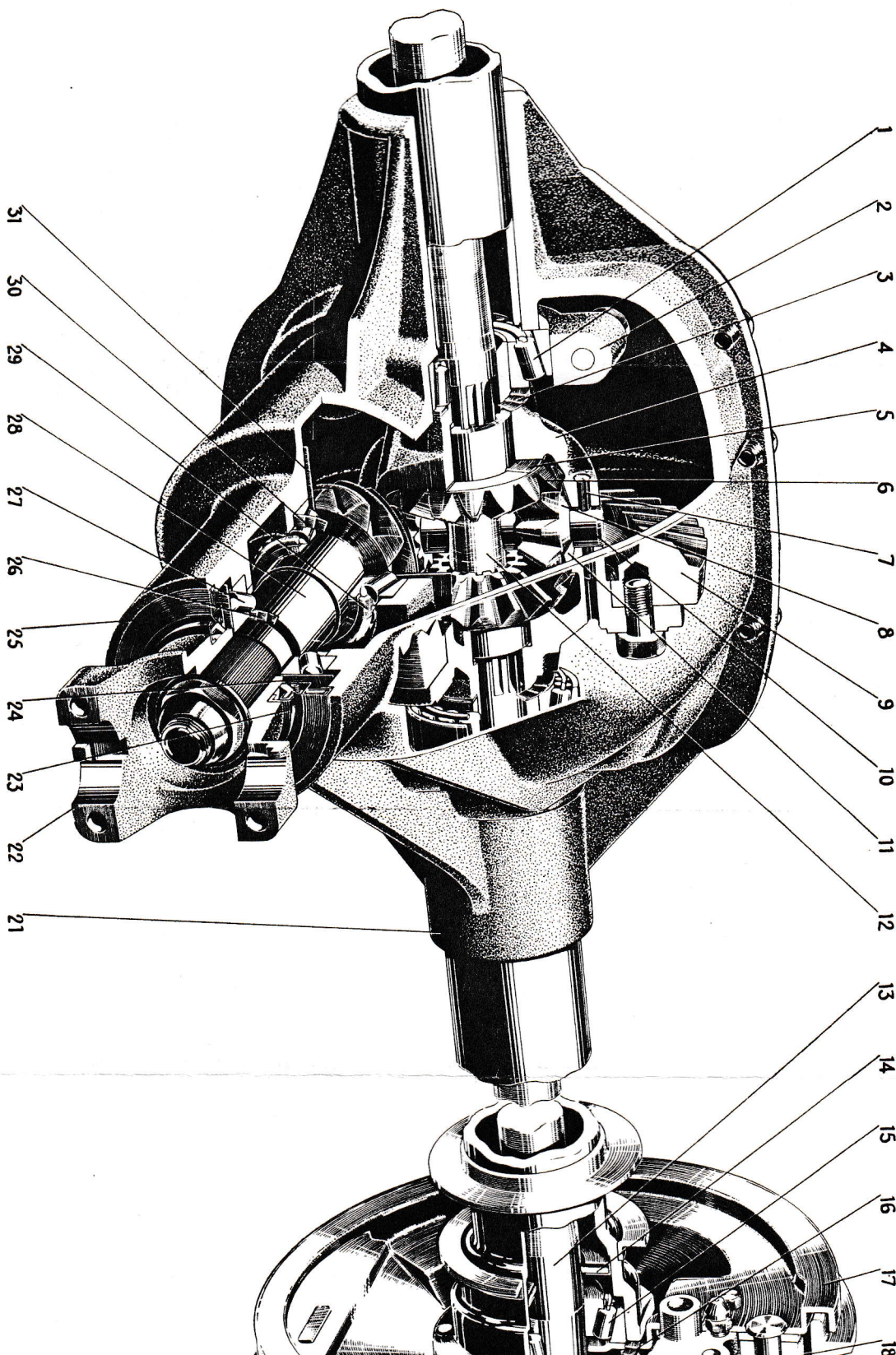

Illustration III. Rear axle, Spicer mod. 27

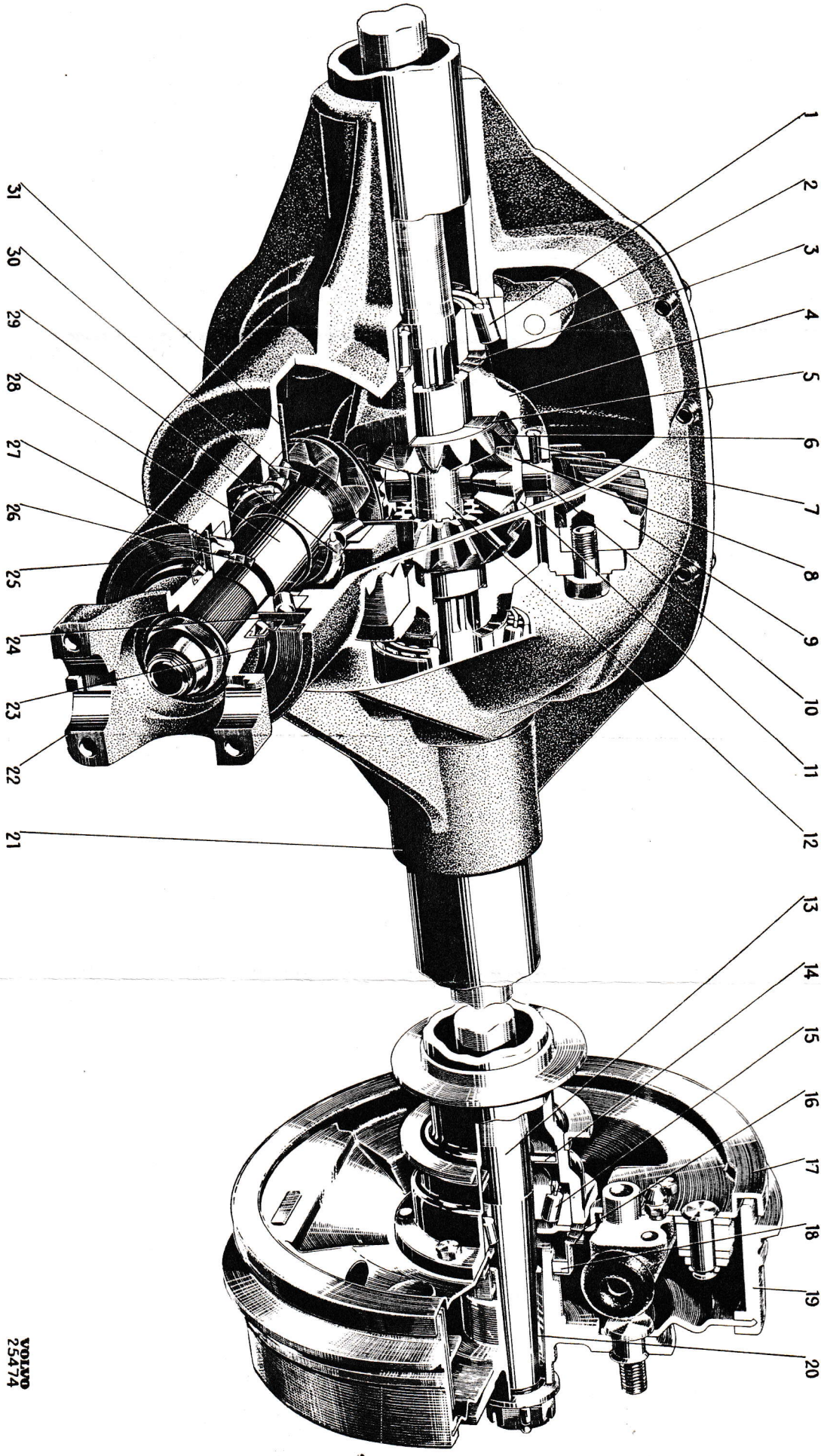

Illustration III. Rear axle, Spicer mod. 27

VOIYO
25474