

GROUP 94

HEATER SYSTEM DESCRIPTION

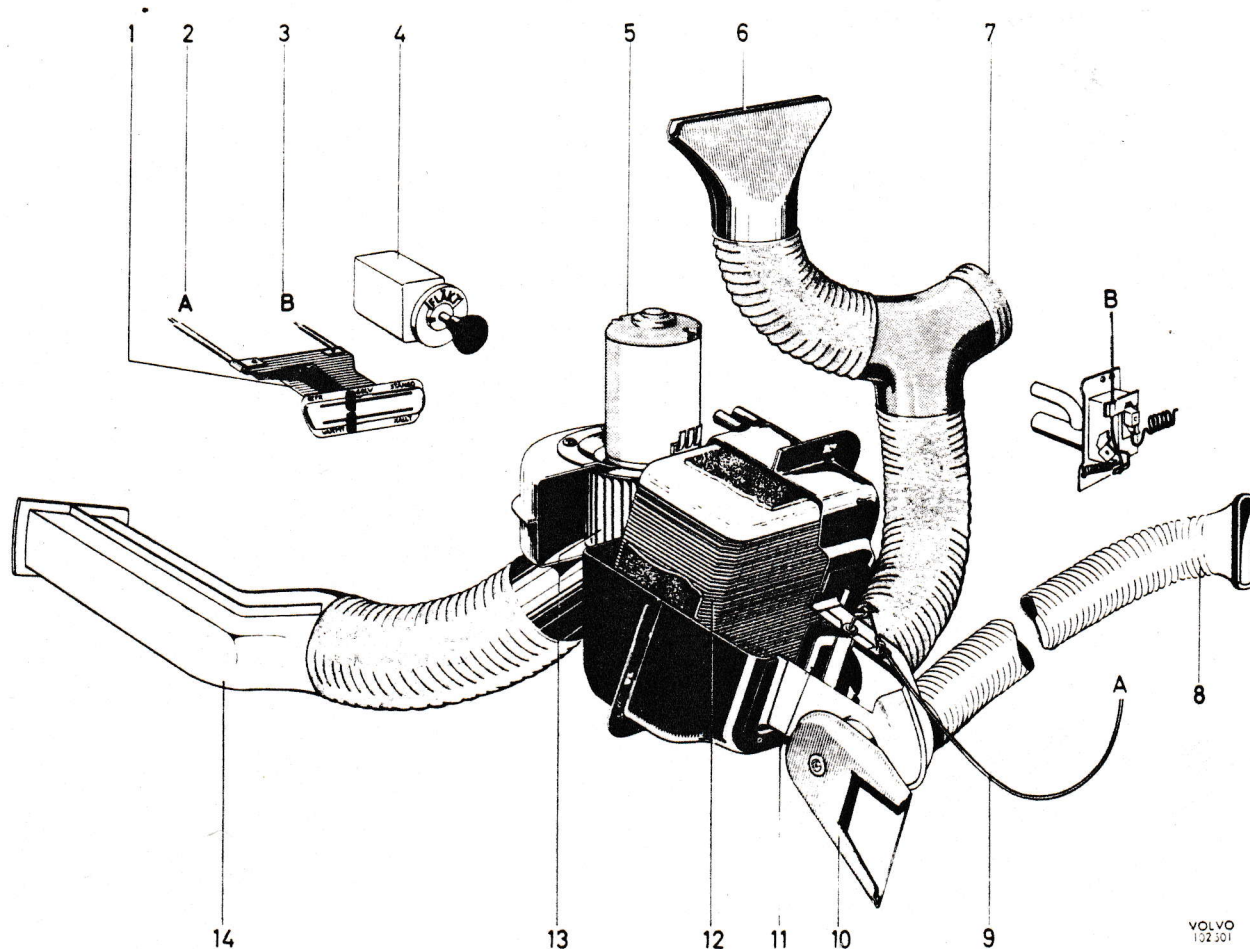

Fig. 17. Heater

- | | |
|----------------------------|-------------------------|
| 1. Heater controls panel | 8. Air nozzle, right |
| 2. Air flow control | 9. Control cable |
| 3. Heater control | 10. Air nozzle, left |
| 4. Fan switch | 11. Distributor shutter |
| 5. Fan motor | 12. Cell system |
| 6. Defroster nozzle, left | 13. Fan rotor |
| 7. Defroster nozzle, right | 14. Air intake |

A. Control cable for shutter

B. Control cable for heater control valve

The heater, Fig. 17, consists of an air intake with fan and motor, cell system, distributor housing with shutter, heater control valve and controls.

Figs. 18 and 19 show the flow of air when the controls are switched to "Floor" and "DEFR" resp.

HEATER CONTROL VALVE

The heater control valve is one of the main parts the heater. The purpose of the valve is to control the supply of heated coolant to the cell system of the heater. This supply is controlled by the valve in two ways; both manually by means of the heater control and automatically through a thermostat arrangement. The function of the heater control valve is shown in Fig. 21.

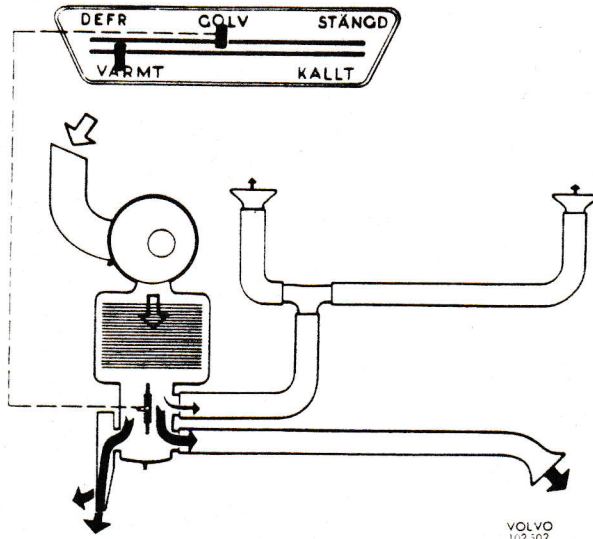

Fig. 18. Air flow, "Floor" position

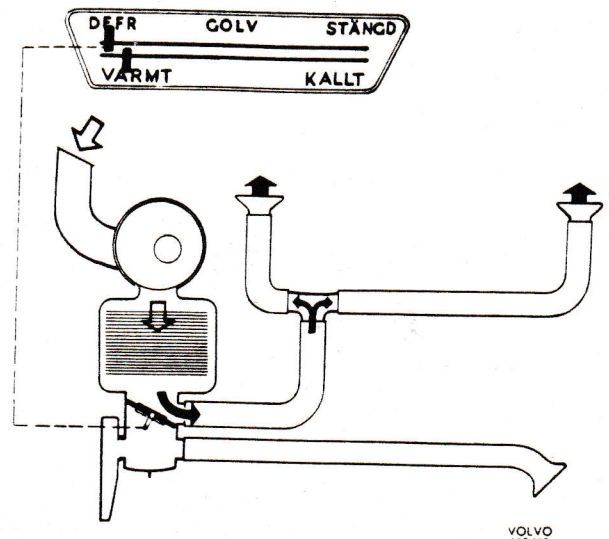

Fig. 19. Air flow, "DEFR" position

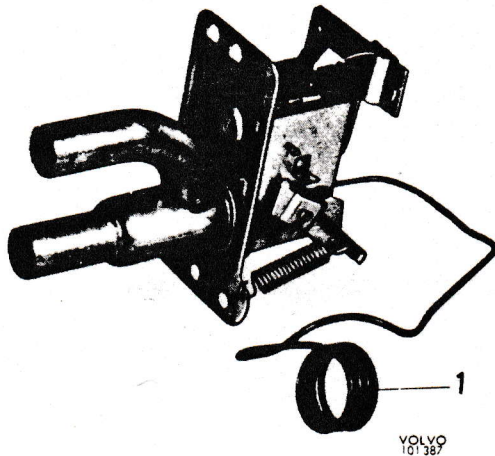

Fig. 20. Heater control valve
1. Sensitive coil for thermostat

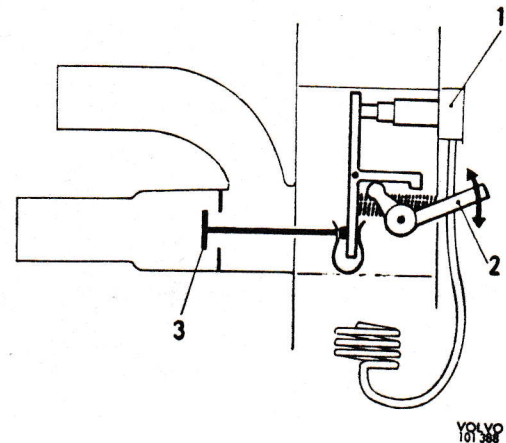

Fig. 21. Simplified sketch of heater control valve function
1. Thermostat 2. Lever for heater control 3. Valve

When the heater control is moved downwards (the lever on Fig. 21 is thereby pulled upwards), the valve is opened and coolant supply to the cell system begins. The air passing through the cell system is thereby heated up and then conveyed to the lower part of the heater in which the shutter arrangements and sensitive coil of the thermostat are placed. When the air flowing through has reached a particular temperature, the mixture of volatile liquids in the sensitive coil of the thermostat begins to vaporize. This gives rise to an

increase in pressure which causes the thermostat of the heater control valve to expand. This expansion results in the valve restricting the coolant supply to the cell system, thereby reducing the heat transmitted to the air flowing through. The thermostat then loses some of its expansion and the valve opens again. The continuous repetition of this process causes the temperature of the air flowing into the vehicle to be maintained constant at the desired level.

REPAIR INSTRUCTIONS

HEATER

Removing

1. Drain out the coolant.
2. Remove the rubber hoses on the heater control valve and cell system.
3. Unhook the control cables on the shutters and heater control valve. Disconnect the electric cables from the fan motor.
4. Disconnect the hose from the air intake and the hoses from the shutter housing.
5. Remove the nuts and lift off the shutter housing and heater.
6. Remove the screws and also the heater control valve.

Dismantling

1. Unscrew the six screws and lift off the fan motor and fan. The fan wheel is pulled by the engine shaft after the lock screw has been released.
2. Remove the drain cap. Unscrew the screws holding the heater halves together and separate the valves.
3. Lift up the cell system and remove the protective cardboard.

Checking the cell system

Clean the cell system externally and lower it under pressure (max. $1.2 \text{ kg/cm}^2 = 17 \text{ lb/sq.in.}$) into water heated to about $70\text{--}80^\circ \text{ C}$ ($160\text{--}180^\circ \text{ F}$). The joints in the cell system are soldered. The connecting points are brazed. If any leakage is discovered, the point concerned should be cleaned very thoroughly so that the new solder can flow in properly. After sealing has been completed, check the cell system again for leakage in accordance with the above instructions.

Assembling

1. Fit the rubber support buttons of the cell system and the protective cardboard. Fit the cell system, see Fig. 22.
2. If necessary, replace any missing rubber sealing strip with new. This is placed in the joint between the two halves before the heater is screwed together.
3. Fit the fan and fan motor.



Fig. 22. Fitting the cell system

VOLVO
102518

Fitting

Make sure that all damaged hoses and gaskets are replaced with new ones. Check that they come properly in position. Handle the heater control valve in the copper pipe with great care.

After fitting, check the shutter, the controls and the fan motor. Fill up with coolant. Start the engine and increase the speed sharply a sufficient number of times to expell the air in the system and then top up with coolant. Repeat this procedure until the cooling system is completely free from air.

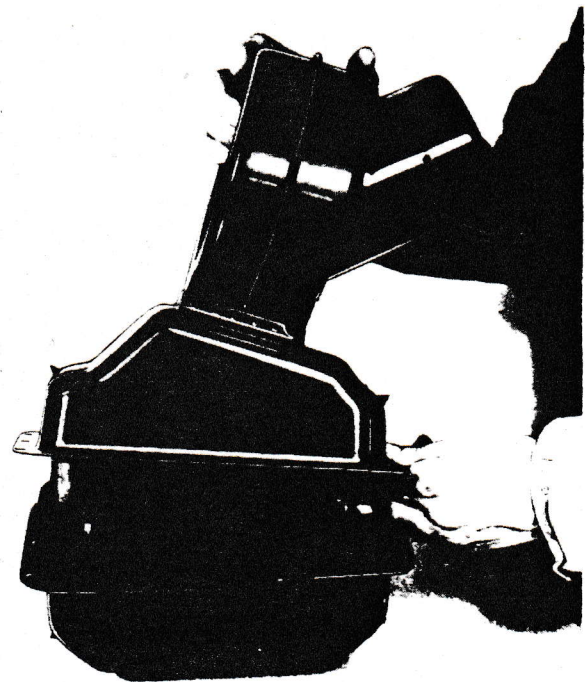

Fig. 23. Assembling the heater

VOLVO
102519

HEATER CONTROLS

Removing

1. Remove the cables for the shutter and heater control valve.
2. Unscrew the nuts holding the control to the dashboard. Pull out the control.

Dismantling

1. Unscrew the screws for the cable clamp. Remove one of the lock washers for the lever shaft. Separate the parts.

Assembling and fitting

Assemble and fit the controls in reverse order to disassembling and removing.

Adjusting

Move up the controls to their closed position. Then check the position of the shutter and heater control valve. If they are not fully closed in this position, they should be adjusted, when the cable coverings at the respective attaching points on the heater or control valves are loosened. After final adjustment, move the controls backwards and forwards a few times to check the function.