

# CONTENTS Q2A

Description .....	1
Footbrake .....	1
Handbrake .....	3
Repair Instructions .....	4
Footbrake .....	4
Wheel brake units .....	4
Adjusting the wheel brake units .....	9
Hydraulic system .....	9
Master cylinder .....	9
Wheel unit cylinder .....	10
Brake lines .....	11
Venting the hydraulic system .....	12
Brake pedal .....	13
Adjusting pedal free play .....	13
Replacing bushing and shaft, see Group 41	
Handbrake .....	14
Replacing the handbrake cable .....	14
Replacing the rubber cover .....	14
Replacing the handbrake lever and ratchet parts .....	14
Adjusting the handbrake .....	15
Fault Tracing .....	16
Tools .....	18
Specifications .....	19

## NOTE

This Service Manual deals with the brake system for the PV 544 equipped with Duo-servo type wheel brake units. Such brakes have been included in production with effect from chassis No. 207866 and on chassis Nos. 205370-205374, 207045-207173 and 207212-207801.

A first small series of PV 544 was equipped with wheel brake units of a different type. Regarding these compare with Service Manual P 120, Part 5, ("Drum brakes").

## DESCRIPTION

The PV 544 and P 210 are fitted with two brake systems which are completely independent of each other. One of these is the footbrake which is controlled by a brake pedal and which operates through a hydraulic system on all four wheels. The other system, the handbrake, is controlled by a brake lever and operates mechanically on both the rear wheels.

### FOOTBRAKE

The lay-out of the brake system is shown in Figs. 1—5.

When the brake pedal (9, Fig. 1) is depressed it actuates the plunger in the master cylinder (7) by means of a link rod (10) and thrust rod.

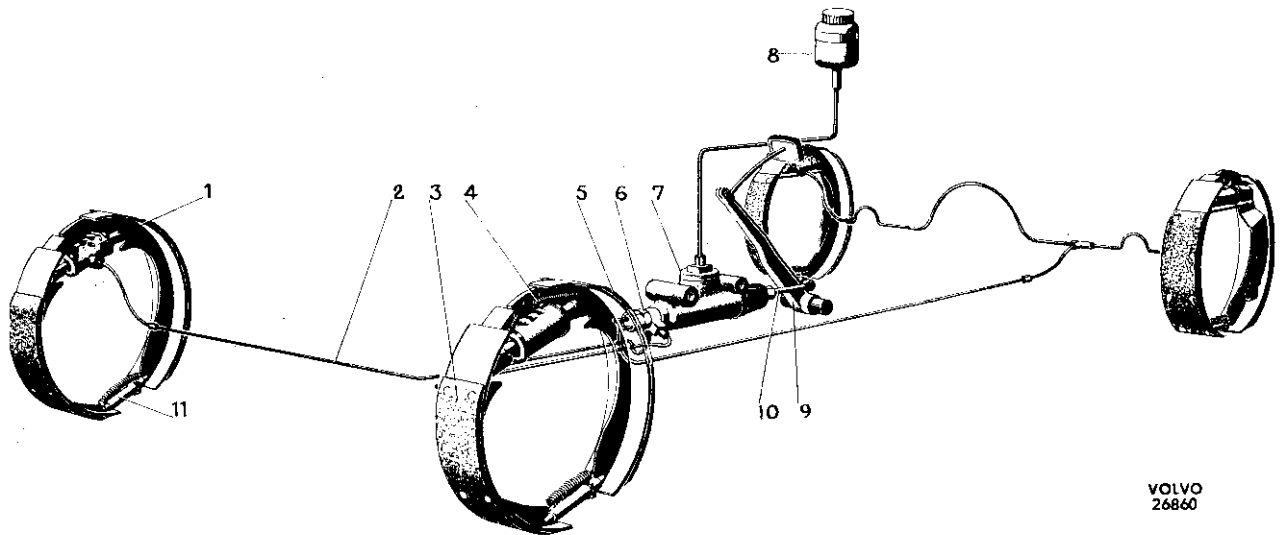

VOLVO  
26860

Fig. 1. Footbrake system

- |                        |  |                      |
|------------------------|--|----------------------|
| 1. Wheel unit cylinder | 5. Rear brake shoe                       | 9. Brake pedal       |
| 2. Brake line          | 6. Brake switch                          | 10. Link rod         |
| 3. Front brake shoe    | 7. Master cylinder                       | 11. Adjusting device |
| 4. Return spring       | 8. Brake fluid container<br>(late prod.) |                      |

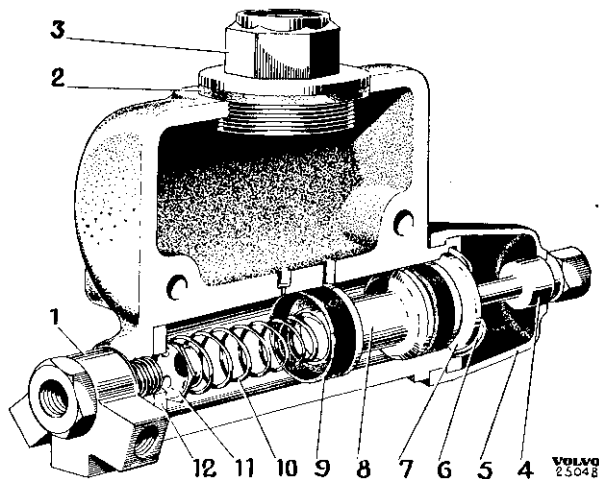

VOLVO  
25048

Fig. 2. Master cylinder (early prod.)

- |                 |                   |
|-----------------|-------------------|
| 1. Branch union | 7. Stop washer    |
| 2. Gasket       | 8. Plunger        |
| 3. Plug         | 9. Packing        |
| 4. Thrust rod   | 10. Return spring |
| 5. Rubber cover | 11. Valve         |
| 6. Locking ring | 12. Packing       |

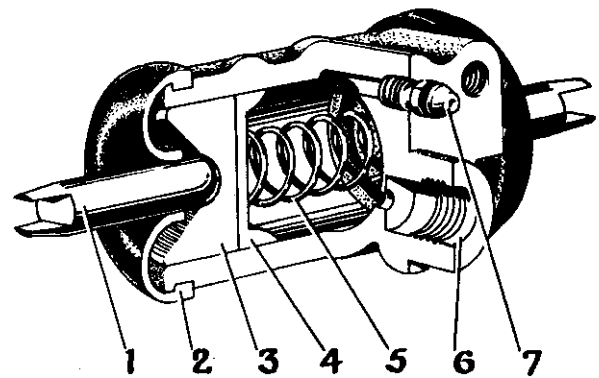

VOLVO  
25049

Fig. 3. Wheel unit cylinder

- |                 |                                 |
|-----------------|---------------------------------|
| 1. Thrust rod   | 5. Spring                       |
| 2. Rubber cover | 6. Connection for brake<br>line |
| 3. Plunger      | 7. Venting nipple               |
| 4. Packing      |                                 |

lic pressure in the master cylinder increases and this is transmitted through the brake fluid in the brake lines (2) to the wheel unit cylinders (1). The plungers in these are thus pressed outwards and apply the brake.

The brake shoes (9 and 12, Fig. 4) are flexibly attached to the brake backing plate by means of guide pins (8) and spring clips (7). The upper ends of the shoes are held pressed against the riveted centering block (3) by the return springs (1). The lower ends are joined by means of an adjusting device (11) against which they are held pressed by the spring (10), which in addition locks the serrated adjusting wheel. This arrangement makes the brake shoes self-centering and both the shoes partly self-applying (Duo-servo).

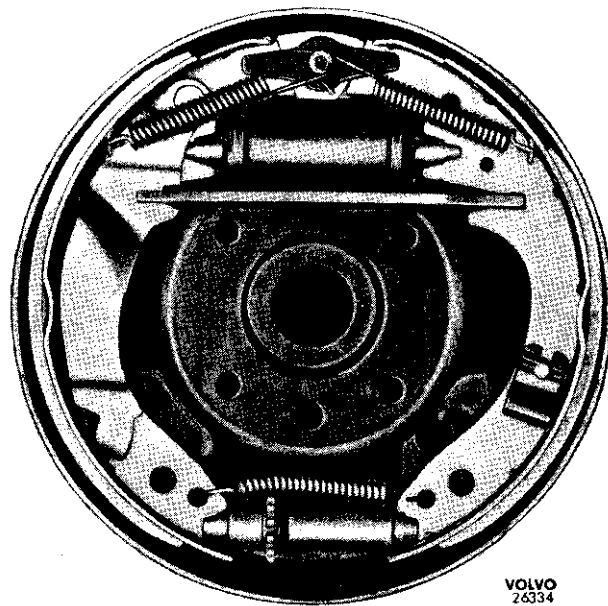

Fig. 5. Wheel brake unit, right rear wheel

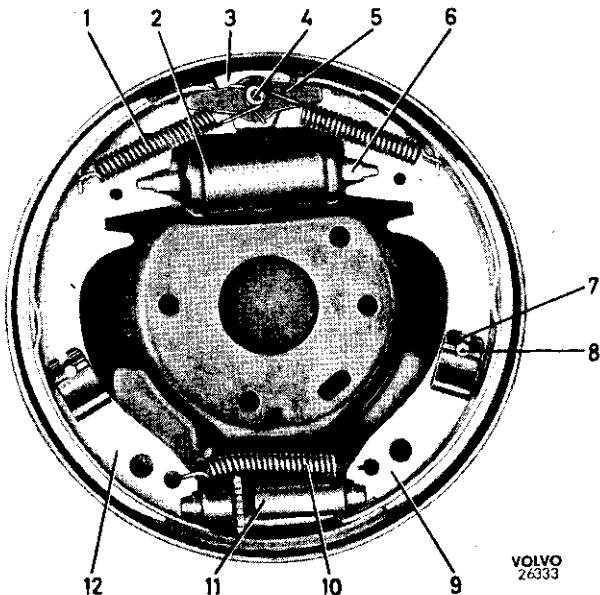

Fig. 4. Wheel brake unit, right front wheel

- |                        |                      |
|------------------------|----------------------|
| 1. Return spring       | 7. Clip              |
| 2. Wheel unit cylinder | 8. Guide pin         |
| 3. Centering block     | 9. Front shoe        |
| 4. Anchor pin          | 10. Locking spring   |
| 5. Guide plate         | 11. Adjusting device |
| 6. Thrust rod          | 12. Rear shoe        |

When the brake is applied, the wheel unit cylinder plungers press out the brake shoes against the brake drum by means of the thrust rods (6, Fig. 4). Because of the friction between the drum and lining, the shoes will follow round in the direction of rotation of the drum. Because of the flexible suspension of the brake shoes, the primary shoe (9) will be pressed downwards and the secondary shoe (12) upwards until its upper end comes up against the centering block, see Fig. 6. The end of the secondary shoe

is then displaced on the block so that the shoe becomes centered in relation to the brake drum. Since the pivoting point of the secondary shoe is at the anchor pin (4, Fig. 4) and that of the primary shoe at the adjusting device, brake application will be assisted by friction between the drum and lining, Fig. 6. This effect is also enhanced by the fact that the primary shoe tends to follow round in the direction of rotation of the brake drum and this has the effect of applying the secondary shoe. In order for the brake linings to attain the greatest possible length of life, the rear shoes (secondary shoes) on the front wheel brake units are fitted with thicker and eccentrically ground linings.

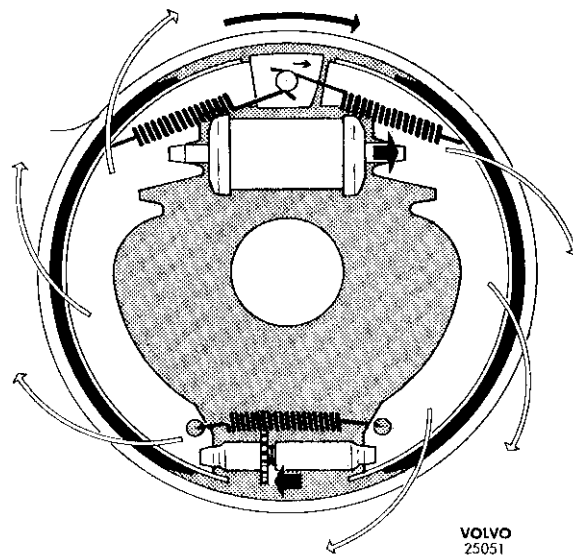

Fig. 6. Application of wheel brake unit

## HANDBRAKE

The handbrake lever is fitted on the tunnel between the front seats. The action of the lever is transmitted through a system of rods and levers to the clevis (12, Fig. 7). From there the movement is transmitted by

cables (14) to the rear wheel brake unit levers (20). The upper ends of these levers are attached to the rear brake shoes. When the levers are pulled forwards the shoes are pressed outwards by means of the link (19) and the handbrake is thus applied.

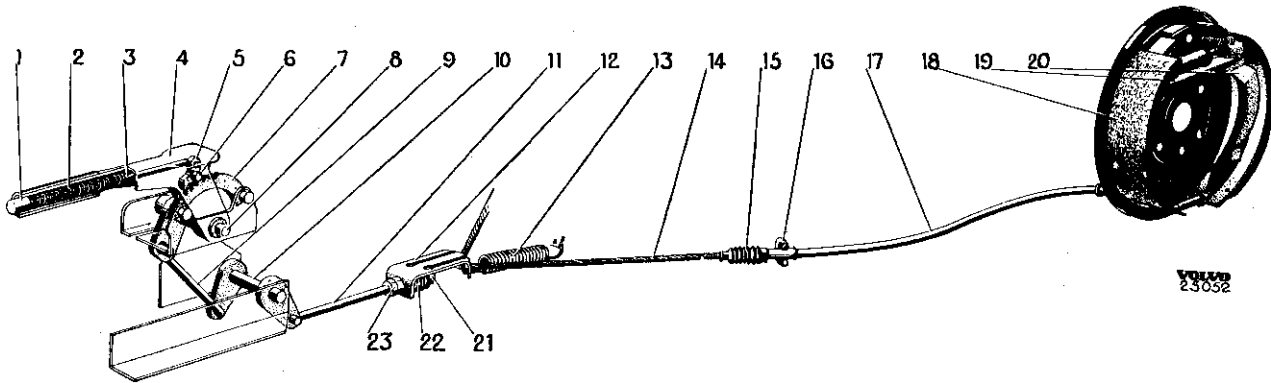

Fig. 7. Handbrake system

- |                          |                       |
|--------------------------|-----------------------|
| 1. Release button        | 13. Return spring     |
| 2. Spring                | 14. Handbrake cable   |
| 3. Thrust rod            | 15. Rubber cover      |
| 4. Handbrake lever       | 16. Attaching clamp   |
| 5. Ratchet catch         | 17. Protective casing |
| 6. Rivet                 | 18. Brake shoe        |
| 7. Ratchet segment       | 19. Link              |
| 8. Shaft                 | 20. Lever             |
| 9. Pull rod              | 21. Nut               |
| 10. Countershaft         | 22. Spring            |
| 11. Pull rod             | 23. Nut               |
| 12. Clevis (early prod.) |                       |

## REPAIR INSTRUCTIONS

### FOOTBRAKE

#### Wheel brake units

##### DISASSEMBLING THE FRONT WHEEL BRAKE UNITS

1. Remove the hub cap and slacken the wheel nuts slightly. Lift up the car and block up under the lower control arm. Remove the wheel.

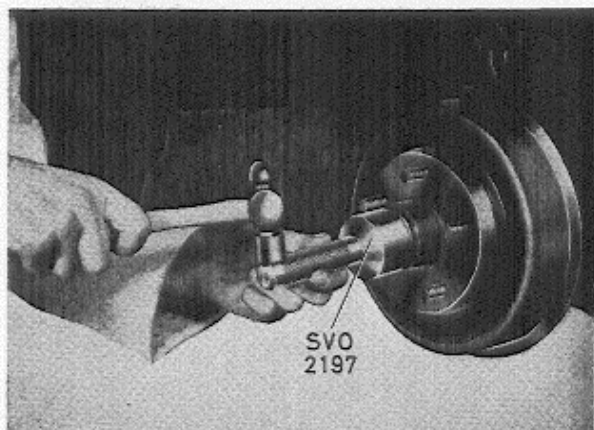

VOLVO  
21931

Fig. 8. Removing the grease cap

2. Remove the grease cap with tool SVO 2197 (Fig. 8). Remove the split pin and castle nut. Pull off the hub with tool SVO 1791 (Fig. 9). If the inner bearing does not come out with the hub, it can be pulled off the spindle with tool SVO 1794 (Fig. 10).

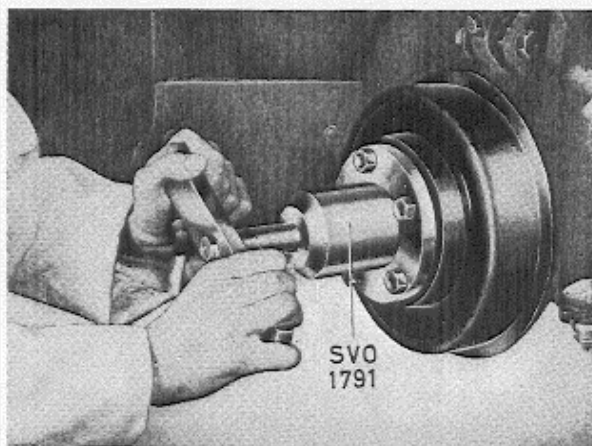

VOLVO  
21922

Fig. 9. Removing the hub

3. Place the clamp SVO 4074 as shown in Fig. 12 so that the plungers in the wheel unit cylinder cannot be pressed out. How the brake shoes are removed will depend upon the tool used. With a brake spring tool, see Fig. 11, disconnect first the two return springs, then remove the locking clips and lift the shoes forward together with the adjusting device.

Disconnect the locking spring with the help of the brake spring pliers as shown in Fig. 12. Pull the shoes apart and remove the adjusting device. Hold against the guide pin on the rear side of the brake backing plate and remove the locking clip. Turn the shoe outwards until the thrust rod from the wheel unit cylinder is released, see Fig. 13. Then turn the shoe inwards until the return spring can be released and the shoe lifted off. Remove the other shoe in the same way.

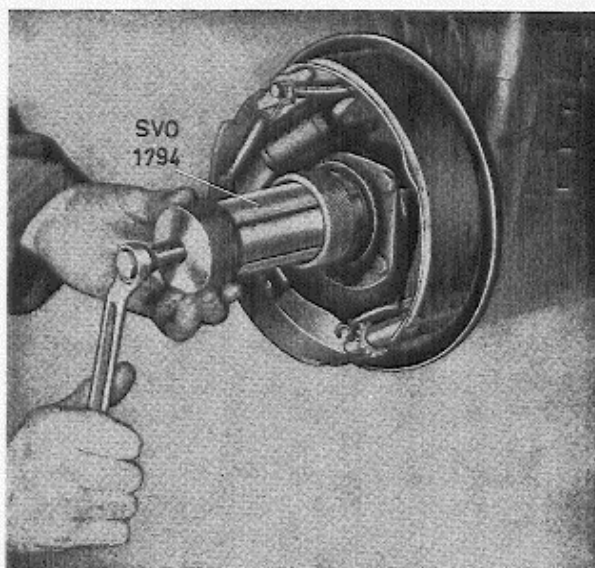

VOLVO  
25053

Fig. 10. Removing the inner bearing

##### DISASSEMBLING THE REAR WHEEL BRAKE UNITS

1. Apply the handbrake. Remove the hub cap. Remove the split pin and slacken the castle nut and the wheel nut slightly. Lift up the car and block up underneath the rear axle. Remove the wheel.
2. Release the handbrake. Remove the split pin and castle nut. Pull off the hub with tool SVO 1791 (Fig. 9).

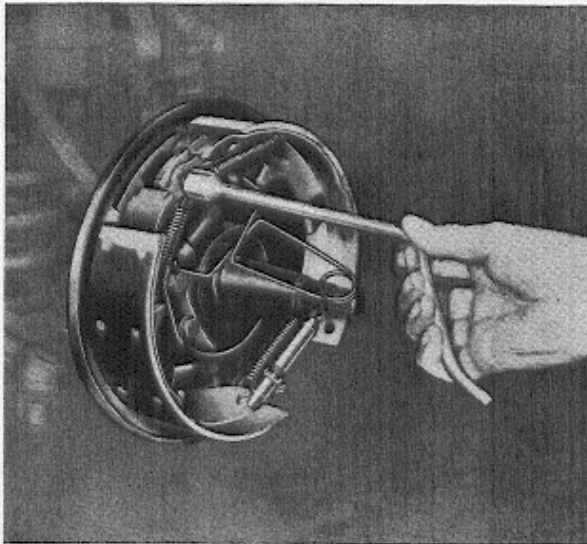

Fig. 11. Removing the return spring with brake spring tool (Snap-on BT 11 or corresponding)

- Place the clamp SVO 4074 over the wheel unit cylinder so that the plungers cannot be pressed out. Disconnect the handbrake cable from the lever. How the brake shoes are removed will depend upon the tool used. With a brake spring tool, see Fig. 11, disconnect first the two return springs, then remove the locking clips and lift the shoes forward together with the adjusting device.

With the help of brake spring pliers unhook the locking spring, see Fig. 12. Pull the shoes apart and remove the adjusting device. Hold against the guide pin on the rear side of the

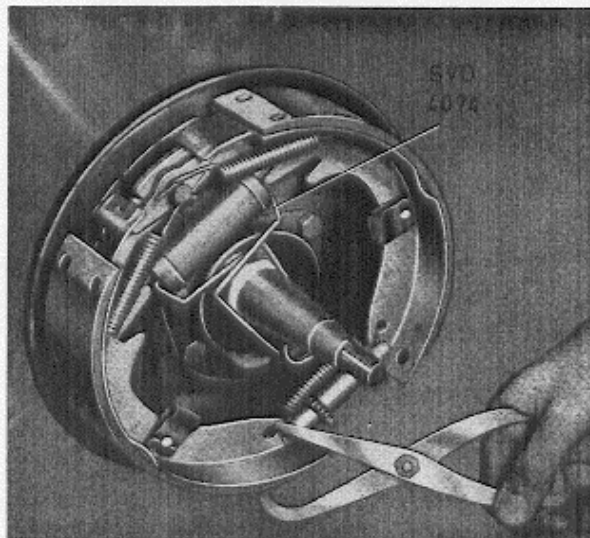

Fig. 12. Removing the locking spring

brake backing plate and remove the locking clip for the rear shoe. Turn the shoe outwards until the thrust rod from the wheel unit cylinder and the handbrake link are released, see Fig. 13. Then turn the shoe inwards until the return spring can be disconnected and the shoe lifted off. Remove the other shoe in the same way.

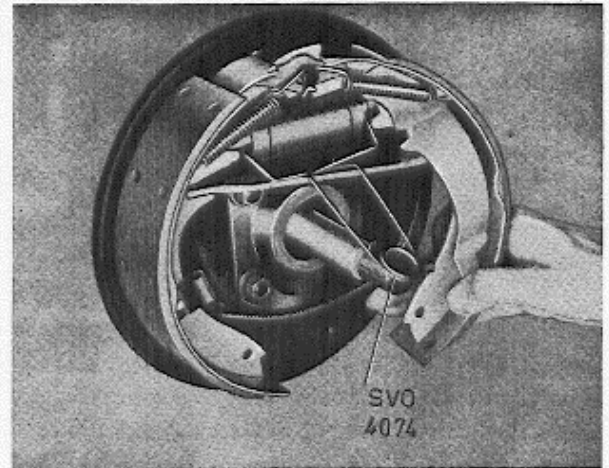

Fig. 13. Removing the brake shoe

#### BRAKE DRUM

Check the friction surface of the brake drums and radial throw. The radial throw should not exceed 0.15 mm (0.006"). If the friction surface is hollow, scratched or cracked, the brake drum should be replaced. Rust spots and small scratches can, however, be polished or ground off.

#### REPLACING BRAKE LININGS

The car may be fitted with different types of brake linings. The linings may be riveted or bonded to the brake shoes, the primary shoes may have long or short linings and the linings may be of two different qualities. The different qualities of linings are characterized by the fact that the early type is marked in red and green with the designation 2201 — H8 stamped on the rear side, while the later type is marked in brown and green and stamped H 3142.

To avoid uneven braking effect, both the wheels on the respective shafts must have the same type of brake lining.

Replacing the brake linings is carried out as follows.

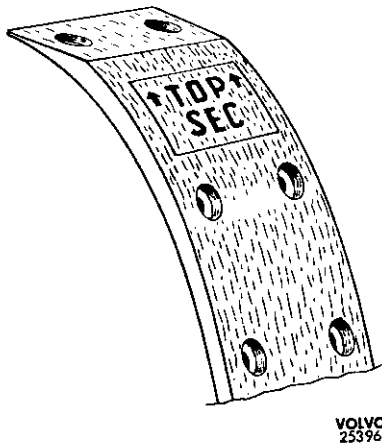

Fig. 14. Rear brake lining of front wheel

**Riveted linings**

Remove the old linings by pressing out the rivets in a rivet press. Then wash the shoes clean and dry them.

Fit the ready-made original lining. **Note that the rear brake shoes of the front wheels (secondary shoes) should be fitted with thicker and eccentrically ground linings marked on the ground side as shown in Fig. 14, that is "TOP SEC". The thicker part (marked) should face upwards. The shorter primary lining should be placed as shown in Figs. 4 and 5 respectively.**

Use rivets as listed in "Specifications". Start riveting at the middle of the lining and make sure that the lining lies flush on the shoe throughout its entire length. Use a rivet press and rivet punches corresponding to the rivet sizes.

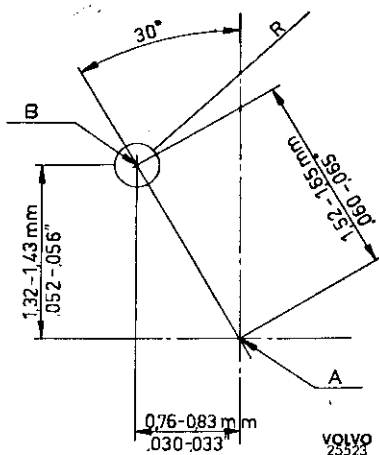

Fig. 15. Eccentricity for rear lining (riveted type) for front wheels

- A = brake shoe centre
- B = pivoting centre
- R = grinding radius

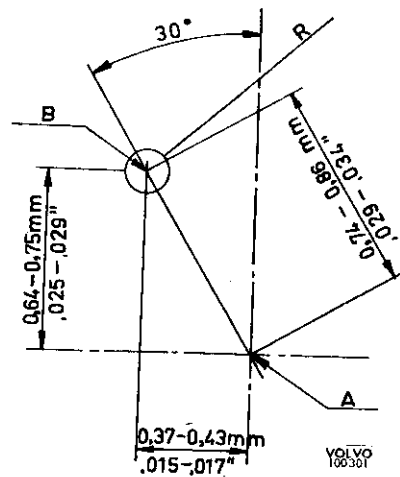

Fig. 16. Eccentricity for rear lining (bonded type) for front wheels

- A = brake shoe centre
- B = pivoting centre
- R = grinding radius

If, for some reason, the riveted linings should be ground, a machine adjustable for eccentric grinding must be used. The eccentricity is shown in Fig. 15 and the grinding radius is for all linings = half the brake drum's diameter reduced by 0.4 (0.016").

**Bonded linings**

Replacement of bonded linings is very simply done by fitting so-called replacement shoes with linings bonded to the shoes.

If the old linings are to be removed, this can be done with a band grinder. They can also be chiseled off, after which the brake shoes must be polished clean with emery cloth. In both cases care is necessary so that the shoe is not damaged.

The bonding procedure varies with different makes of oven and testing units, so that a generally applicable description cannot be given. Therefore follow carefully the recommendations of the manufacturer. When fitting the lining, make sure that it does not come obliquely on the shoe and that it is placed as shown in Figs. 16 to 19. On the rear brake shoes (secondary shoes) of the front wheels 1/4" linings should be fitted and on the other shoes 3/16" linings. When bonding, only bonding compound specially made to withstand high temperatures arising during long braking must be used.

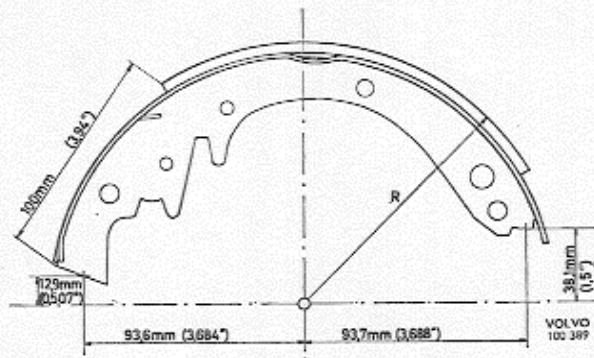

Fig. 17. Adjustment dimensions for front brake shoes

**After bonding, the linings should be ground to the correct dimension**

As the rear brake linings for the front wheels should be ground eccentrically, a grinder is required for this which is adjustable for this type of lining. As there are different makes of such machines, the grinding procedure will depend upon the design of the grinder. Fig. 16 shows how much the pivoting centre should be displaced in relation to the brake shoe centre for grinding the eccentric lining. For other types of linings, the pivoting centre coincides with the centre of the brake shoe.

The grinding radius (R) = half the diameter of the brake drum reduced by 0.4 (0.016"). On machines which are graduated for drum diameters, a value should be set which is 0.8 mm (0.032") less than the diameter of the brake drum.

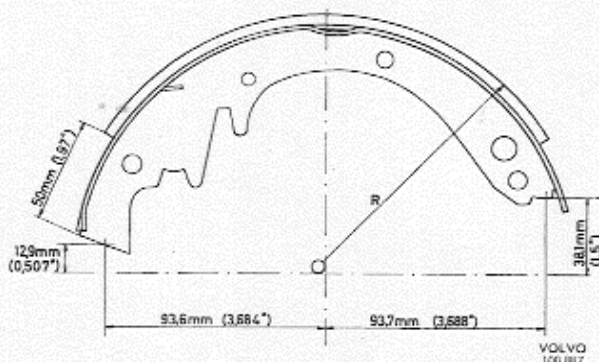

Fig. 18. Adjustment dimensions for the rear brake shoes of the front wheels

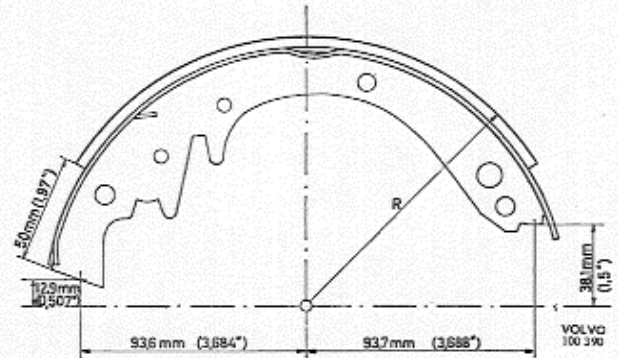

Fig. 19. Adjustment dimensions for the rear brake shoes of the rear wheels

**ASSEMBLING THE FRONT WHEEL BRAKE UNITS**

1. Check and if necessary smooth off the surfaces of the lips on the brake backing plate against which the shoes and the centring block slide. Polish the sliding surfaces on the shoes and centring block. Coat the surfaces with a very thin layer of heat-resistant grease. Place the centring block (3, Fig. 4) in position with the rounded side forwards when the stamped arrow should point in the direction of rotation of the brake drum.

Different types of centring blocks are available. However, on each shaft both the centring blocks must be of the same design. There is on the latest design, in addition to the arrow, a point and an S are stamped. Fit the guide plate (5).

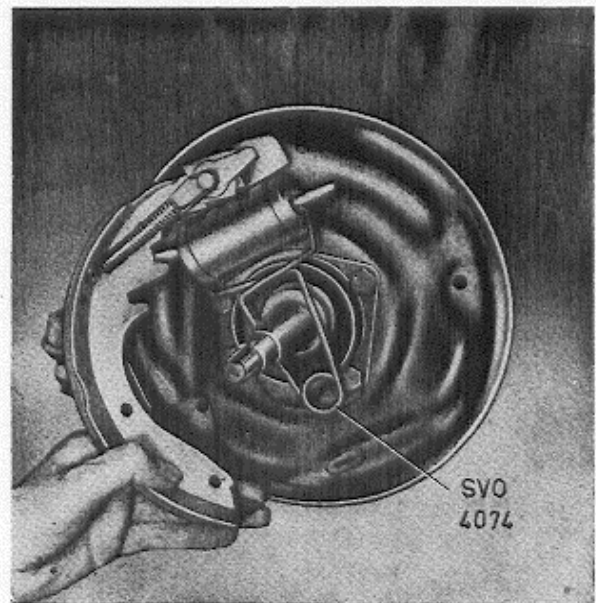
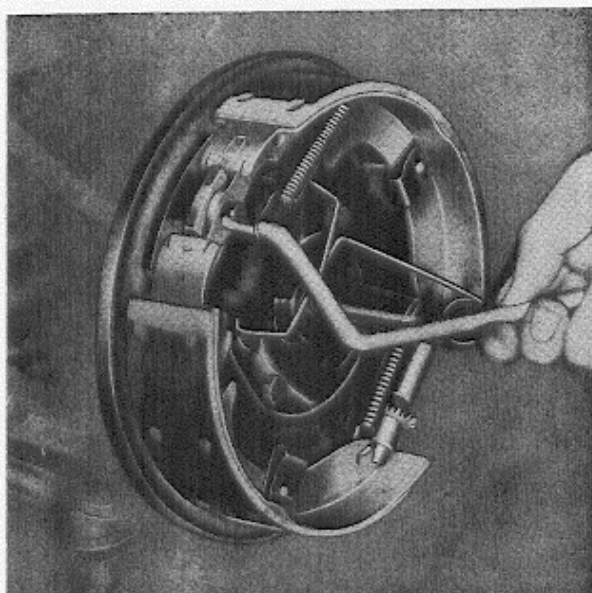

Fig. 20. Fitting the brake shoe

VOLVO  
25057



VOLVO  
24592

Fig. 21. Fitting the return spring with the brake spring tool

2. Hold the front shoe in place so that the return spring can be hooked on. Turn the shoe outwards so that the wheel unit cylinder thrust rod can be placed in position, see Fig. 20. Fit the guide pin (8) and clip (7).

Fit the rear shoe in the same way. Remove the clamp SVO 4074. Fit the adjusting device and its locking spring.

If there is a brake spring tool as shown in Fig. 21 available, one can instead begin by fitting the adjusting device and locking spring and then by placing the shoes in position. The locking clips are then fitted and the return springs hooked on with the pointed end of the tool, see Fig. 21.

3. Check that the springs and locking clips are properly in position, that the linings are free from burr, grease and dirt and that the thicker part of the lining on the rear shoe faces upwards.
4. If the inner front wheel bearing has been removed, place this in position in the hub. If

necessary, pack this with ball bearing grease. Press in the sealing rings using drift SVO 1798 and standard handle SVO 1801.

5. Fit the hub and the brake drum cleaned on the spindle. Fit on the outer bearing, washer and castle nut. Adjust the bearings by first tightening the nut to a torque of 7 kgm (50 lb.ft.). Then slacken the nut  $\frac{1}{3}$  of a turn and lock it. Fill the grease cap with grease and fit it with drift SVO 2197.
6. Fit the wheel. Adjust the brake, see under "Adjusting the wheel brake units". Lower the car. Tighten the wheel nuts to a torque of 10—14 kgm (70—100 lb.ft.). Fit on the hub cap.

#### ASSEMBLING THE REAR WHEEL BRAKE UNITS

1. Proceed in accordance with points 1 and 2 under "Assembling the front wheel brake units". Place the handbrake link with spring in position in the front shoe before fitting the rear shoe. Connect up the handbrake cable.
2. Check that the springs and locking clips are properly in position and that the linings are free from burr, grease and dirt.
3. Fit the hub, the brake drum cleaned, washer and castle nut. Fit the wheel. Adjust the brake, see under "Adjusting the wheel brake units". Lower the car. Lock the castle nut with the split pin after having tightened the nut thoroughly. Tighten the wheel nuts to a torque of 10—14 kgm (70—100 lb.ft.). Fit on the hub cap.

#### TEST DRIVING

When test driving after replacing the brake linings, avoid repeatedly hard braking at high speeds. Such braking with linings which are not worn in can give rise to overheating and cause permanent local damage to the linings. Instead, brake repeatedly with light pressure but with relatively long intervals in between to allow the linings to cool.

## ADJUSTING THE WHEEL BRAKE UNITS

If it is suspected that the linings are worn, the brake drum should be removed so that this can be checked. The adjusting device permits an adjustment even if the linings are worn down to the rivets and such wear can lead to the rivets damaging the drums. The linings should be examined regularly every 10,000 km (6,000 miles), but more often if hard driving is involved.

Adjusting is done as follows:

1. Lift up the car and place blocks under the control arms or rear axle respectively. Release the hand brake.
2. Remove the rubber seal. Rotate the wheel in its **normal direction of rotation** (not forwards and backwards) while the brake shoes are placed against the brake drum with the help of the adjusting screw. To turn this screw, use a screwdriver or tool as shown in Fig. 22. When it is just possible to turn the wheel by hand, discontinue applying the shoes. Then turn back the adjusting screw 12 notches. Fit the rubber seal.

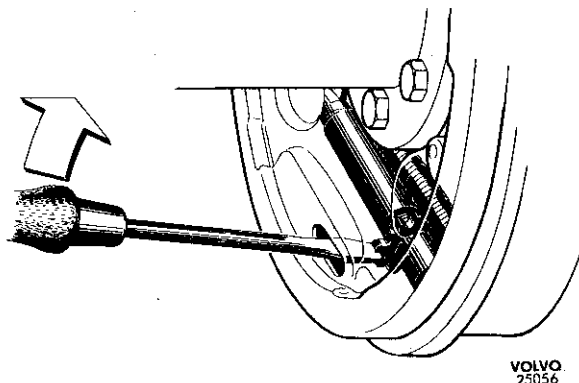

Fig. 22. Adjusting the wheel brake unit

## Hydraulic system

Observe the greatest possible cleanliness in all work involving the hydraulic system. Wash your hands with soap and water before cleaning the internal parts. The parts should be washed in metholated spirit. Gasoline (petrol), kerosene, trichlorethylene or spirit containing benzol must not be used.

For topping up purpose use only high-class brake fluid which fulfills the requirements of SAE 70 R 3. Avoid spilling any brake fluid on the paintwork as this can cause damage.

## Master cylinder

### REMOVING

The master cylinder is removed from underneath. Remove the protecting plate and disconnect the brake line connections on the cylinder and the leads for the brake contact. The later type has a master cylinder with a separate brake fluid container. To remove the master cylinder on this model, therefore, the line from the brake fluid container must first be disconnected and the brake fluid allowed to run out into a vessel. Disconnect the link rod from the brake pedal. Unscrew the two screws securing the master cylinder to the body and lift the cylinder forwards. Avoid spilling any brake fluid.

### DISASSEMBLING

1. Blow the master cylinder clean externally. Remove the sealing plug and empty out the brake fluid.
2. Pull the rubber cover (5, Fig. 2) off the master cylinder and remove the thrust rod (4) with rubber cover.
3. Take out the plunger (8), packing (9), return spring (10) with valve (11) and packing (12).
4. Remove the three-way union (1) with brake contact.

### INSPECTING

Before inspecting, all parts of the master cylinder should be washed in metholated spirit.

The cylinder should be examined thoroughly internally. There should be no marks, scratches or rust spots on the polished surface. Such damage can usually be eliminated by means of honing. The procedure for doing this varies with different types of tools so that no general description can be given. Follow, therefore, the instructions of the manufacturer. Clean the cylinder carefully after honing and check that the equalizing valve is clear.

The clearance between plunger and cylinder should be maximum 0.25 mm (0.010") and can be calculated by measuring the plunger bore with a micrometer and the cylinder with an indicator. Minimum permissible plunger bore is 25.25 mm (1"). The free length of the return spring should be 75 mm (2.95"). Each time reconditioning is carried out, the packings should be replaced with new ones. Damaged or worn parts should also be replaced.

### ASSEMBLING

Before assembling ensure that the two holes between the cylinder and fluid container and the overflow holes in the plunger are open.

1. Place the packing (12, Fig. 2) and valve (11) and return (10) in the cylinder.
2. Fit the rear packing on the plunger (8). Dip the plunger and packing (9) in brake fluid and press them into the cylinder. Place the stop washer (7) in position and fit the locking ring (6).
3. Place the thrust rod (4) in the plunger (8) and pull the rubber cover (5) over the shoulder on the master cylinder. Fit the three-way union (1) with brake contact.
4. Check that the equalizing hole is clear by pushing a 0.5 mm (0.02") wire through it (Fig. 23). It should then be possible to press the plunger in about 0.5 mm (0.02") (A, Fig. 16) before the wire becomes caught. Be careful to avoid damaging the packing. If the equalizing hole is not clear, this usually means that the master cylinder has been incorrectly assembled.

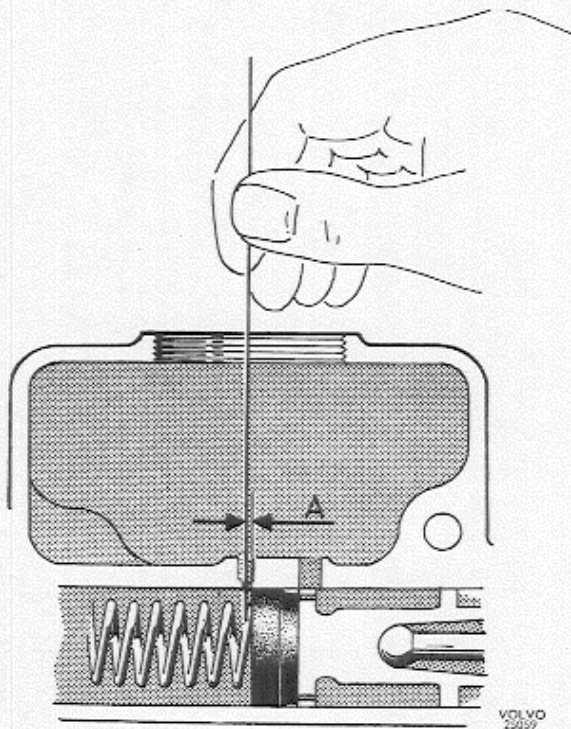

Fig. 23. Checking the equalizing hole



Fig. 24. Removing the wheel unit cylinder

### FITTING

The master cylinder is fitted in the reverse order to removing.

Fill up with brake fluid and vent in accordance with the instructions under "Venting brake system".

Check and if necessary adjust the brake pedal free travel. This should be 7—12 mm (1/4—1/2") and should be adjusted in accordance with the instructions under "Adjusting the free travel".

### Wheel unit cylinder

#### REMOVING

1. Remove the hub, see points 1 and 2 under "Assembling the wheel brake units".
2. Place clamp SVO 4074 over the wheel unit cylinder. Move the brake shoes to the side with the help of a screwdriver sufficiently for the thrust rods to be released from the shoes, see Fig. 24.
3. Remove the brake lines and wheel unit cylinder attaching bolts. Lift the wheel unit cylinder forwards but ensure that no brake fluid gets on to the linings.

## RECONDITIONING

Remove the clip, pull off the rubber seals (2, Fig. 3) and take out the plungers (3), packings (4) and spring (5). Wash all parts in methylated spirit.

Examine the cylinder carefully internally. There must be no marks, scratches, or rust spots on the polished surface. Such damage can be eliminated through honing the cylinder. Since the procedure for this varies with different tools, follow the instructions of the respective manufacturers. Clean the cylinder carefully after honing when the venting nipple should be removed. The clearance between plunger and cylinder should be maximum 0.25 mm (0.01") and can be calculated by measuring the plunger bore with a micrometer and the cylinder with an indicator. If the clearance exceeds 0.25 mm (0.01"), test with a new plunger. If this does not help, the wheel unit cylinder must be replaced.

The clearance can also be measured with the help of a feeler gauge as shown in Fig. 25. Since this measuring method does not show the maximum clearance in the same way as the method described above, the maximum clearance measured in this way should not exceed 0.15 mm (0.006").

Each time reconditioning is carried out, the packings and rubber covers should be replaced with new ones. Damaged or worn parts should also be replaced.

Assemble the parts in the reverse order to disassembling. When doing so, dip the plungers and packings in brake fluid.

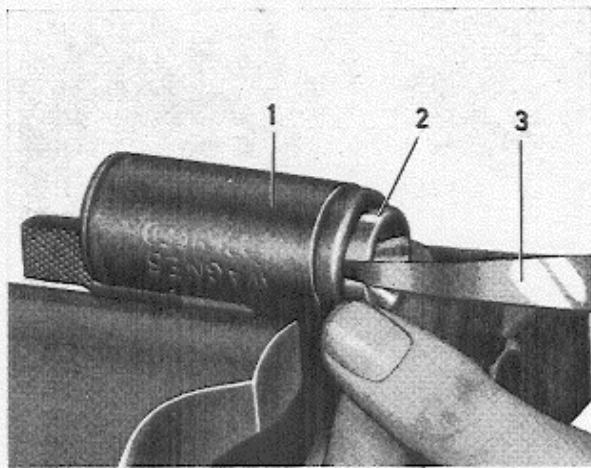

Fig. 25. Checking the clearance

1. Wheel unit cylinder 2. Plunger 3. Feeler gauge

## Brake pipelines

The brake pipelines should be flushed in connection with a total overhaul of the hydraulic system. The pipelines are then disconnected at the wheel unit cylinders and are flushed one after the other with brake fluid or spirit. Flushing can be suitably carried out by filling the master cylinder with methylated spirits and then depressing the brake pedals several times.

After all the lines have been flushed with spirit, they should be blown clean with filtered compressed air free from water because spirit can give rise to vapour bubbles in the system and result in a spongy pedal.

Should leakage occur or if any of the lines should become damaged in such a way, that the risk of leakage is likely, the damaged lines must be replaced. Replacement should be carried out in the following way:

1. Remove the damaged brake pipeline.
2. Take a new original brake pipeline, blow it clean internally with filtered compressed air free from water and fit it. Make sure that the brake pipeline takes up such a position that it does not lie and chafe during driving. Particularly important points to note are where the pipes pass over the rear spring attachments at the rear axle where the pipe must not lie nearer the clamps than 10 mm ( $\frac{3}{8}$ " ) and also where they pass the support arms. If the pipe is not bent correctly, this should be adjusted by hand when the pipe is not fitted. Bending a mounted pipe often results in deformations at the attachment.
3. Vent the hydraulic system.

If, for any reason, the brake line is not ready-made, it can be made in accordance with the following description:

1. Cut off the new Bundy pipe to the requisite length. Remember that flanging shortens the pipe about 8 mm ( $\frac{5}{16}$ " ). The pipe should be cut at right angles and all burr removed.
2. Place tool SVO 2049 in a vice. Insert the pipe so far that its end comes flush with the clamp jaw as shown in Fig. 26. Tighten the nuts.

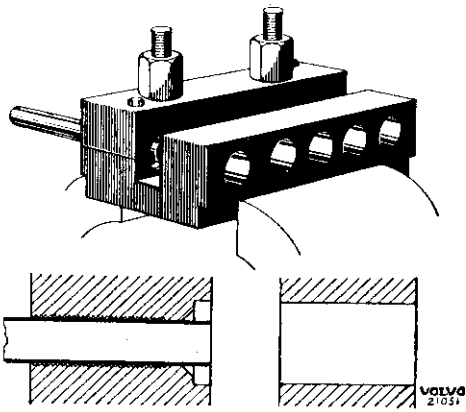

Fig. 26. Flanging the brake pipeline

3. Place drift OP 1 in the tool. Strike the drift with copper mallet until the drift bottoms. The edge of the pipe is thus flanged as shown in Fig. 27.
4. Replace the drift with OP 2 (Fig. 28) and drive this in until it bottoms.
5. Fit on the union nuts and repeat operations 3—5 at the other end of the pipe.
6. Bend the brake pipeline using the old one as a pattern. Bending should be done round an object having the same radius as the bend required. Any adjustment should be carried out with the pipe not fitted. Bending of a mounted pipe often results in deformations at the attachment.

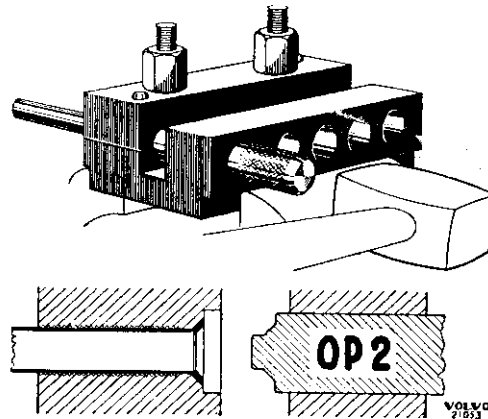

Fig. 28. Flanging the brake pipeline

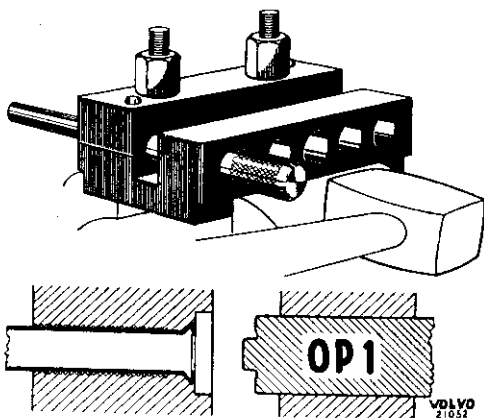

Fig. 27. Flanging the brake pipeline

## Venting the hydraulic system

Air is prevalent in the system if the brake pedal can be depressed without any considerable resistance or if it feels "spongy".

Venting must be carried out after any part of the system has been removed. Air can also enter the system if there is too small a quantity of brake fluid in the container. If, for example, only one wheel unit cylinder has been removed, it is usually sufficient to vent just this one. If, on the other hand, the master cylinder or lines from this have been removed, then the whole brake system must be vented.

Venting of the whole brake system is done as follows:

1. Clean round the filling cap and venting nipples.
2. Remove the master cylinder cap with tool SVO 2384 and unscrew the cap on the brake fluid container. If necessary, top up with first-class brake fluid which meets the requirements according to SAE 70 R 3. For a master cylinder of earlier design, it is preferable to use a special filling bottle as shown in Fig. 29. When doing so, screw the plug (2) into the place of the cap. Insert the pipe down through one of the holes in the plug and open the tap (1). The bottle will then keep the fluid level constant and at the correct level during venting.

- Place key SVO 1431 with hose on the venting nipple and immerse the other end of the hose in a collecting vessel, see Fig. 30.
- Open the nipple and have someone slowly depress the brake pedal several times. Keep the nipple open as long as air bubbles appear in the fluid which runs out. Then close the nipple while the brake pedal is fully depressed.
- Vent the other wheels in the same way. Then close the tap on the filling bottle and remove the bottle. Check the gasket and screw on the cap.

A special venting device can be used when venting and this maintains the fluid in the system under positive pressure. In this case, the brake pedal is not required to be depressed, so that venting can be carried out by one person.

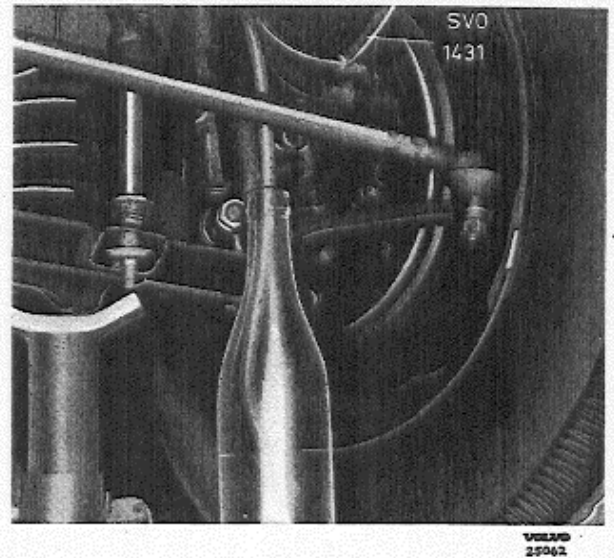

Fig. 30. Venting

## Brake pedal

### ADJUSTING FREE TRAVEL

It is important that the brake pedal should have the correct free travel. If this is too small, the equalizing hole between the cylinder and the fluid container will be blocked by the plunger packing with the result that the brake shoes are prevented from returning to their rest position. If the free travel is too great, the effective stroke may be insufficient so that "pumping" must be carried out in order to obtain full brake effect.

Adjusting the brake pedal free travel is done by adjusting the length of the link rod (3, Fig. 31). When doing this, slacken the locking nut (2) and turn the thrust rod (1) until the pedal has a free travel of 7—12 mm ( $\frac{1}{4}$ — $\frac{1}{2}$ " (measurement A). Tighten the locking nut.

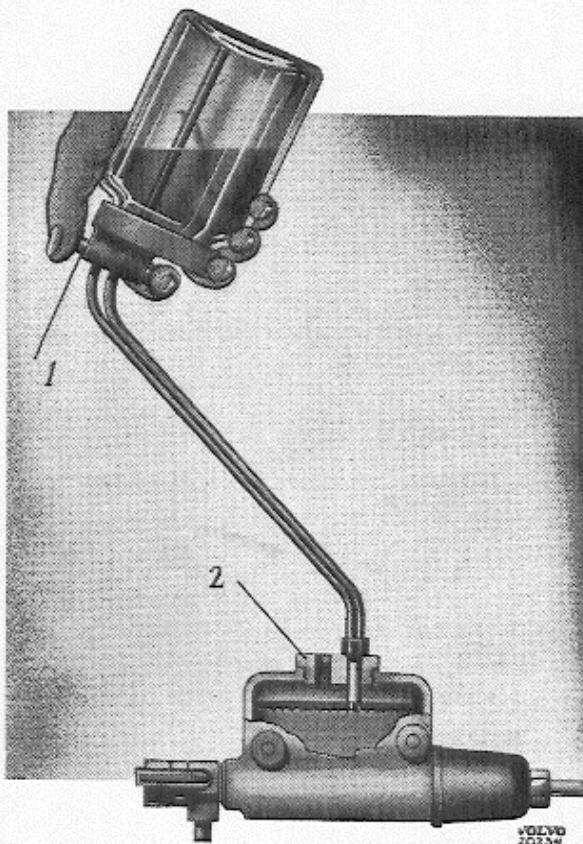

Fig. 29. Filling with brake fluid, early prod.

1. Tap      2. Plug

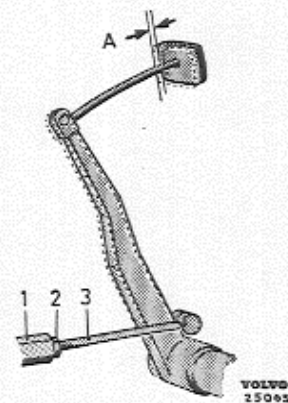

Fig. 31. Adjusting the brake pedal free travel

1. Thrust rod      2. Locking nut      3. Link rod

### REPLACING BUSHING AND SHAFT

This is done in conjunction with reconditioning the clutch pedal, see Service Manual, Part 2 under the heading "Reconditioning the pedal shaft".

## HANDBRAKE

### Replacing the handbrake cable

#### REMOVING

1. Apply the handbrake, remove the hub cap, slacken the wheel nuts and castle nut.
2. Lift up the rear of the car, place blocks under the rear axle and remove the wheel. Release the handbrake.
3. Remove the bolts and the cable outer casing attachment in the brake backing plate. Remove the cable outer casing front attachment and spring. Remove the split pin and release the pull rod (11, Fig. 7). Unhook the cable from the clevis.
4. Pull off the brake drum and hub with puller SVO 1791, see Fig. 9. Remove the cable from the brake shoe lever and pull the cable forwards.

#### FITTING

1. Insert the cable in the brake shoe and hook it on to the lever.
2. Hook the cable onto the clevis and fit pull rod and split pin. Bolt the cable outer casing attachment to the brake backing plate and fit the spring.
3. Place on the hub, brake drum and wheel. Tighten the castle nut and wheel nuts sufficiently for the brake drum and wheel to take up the correct position.
4. Adjust the handbrake. Lower the car and tighten the wheel nuts to a torque of 10—14 kgm (70—100 lb.ff.). Tighten and lock the castle nut. Fit on the hub cap.

### Replacing the rubber cover

If the rubber cover at the front end of the cable outer casing has been damaged for any reason it must be replaced otherwise water and dirt can penetrate into the outer casing and the cable could gradually become rusted up.

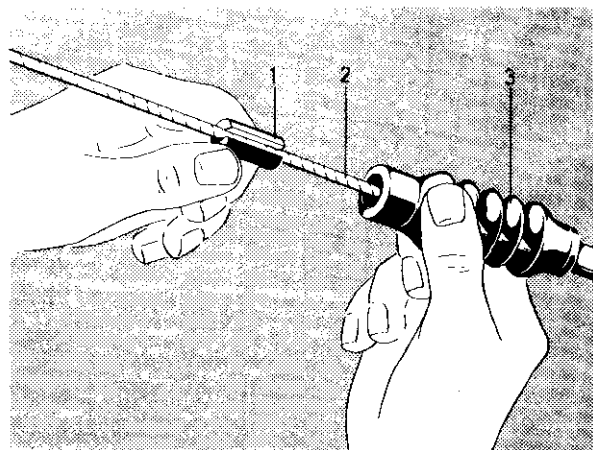

Fig. 32. Fitting the rubber cover

1. Sealing plug      2. Cable      3. Rubber cover

For this replacement there is a special rubber cover (part No. 86850 for PV 544 and part No. 656945 for P 210) with sealing plug (part No. 86851).

When replacing, remove the rear pull rod from the countershaft and unhook the cable from the clevis. Cut off the old casing and place on the new one. Hook the cable onto the clevis and fit the pull rod back in position. Fit the slotted sealing plug (1, Fig. 32) onto the cable (2) and press it into the rubber casing (3).

### Replacing the handbrake lever and ratchet parts

1. Lift up the rear of the car and place blocks under the rear axle.
2. Remove the split pin and draw the cables so that the front pull rod can be released from the countershaft. Then unhook the pull rod from the handbrake lever arm, see Fig. 33.
3. Remove the cover over the handbrake lever attachments. Lift up the mat over the propeller shaft tunnel and remove the ratchet segment. Remove the split pin and knock out the lever shaft as shown in Fig. 34. Pull out the handbrake lever forwards.
4. Screw off the release button, (1, Fig. 7) and remove the spring (2) from the handbrake lever. Drill out the rivet (6) and take out the ratchet catch. In late production, the stop screw and yoke are first removed.

VOLVO  
25064

Fig. 33. Removing the pull rod

VOLVO  
26934

Fig. 35. Adjusting the handbrake

5. Fit the new parts in reverse sequence. Check that the ratchet catch can move easily after riveting. If a new rubber seal is to be fitted, this should be stuck onto the attaching plate on the tunnel with adhesive. Do not forget to lock the shaft and pull rod with split pins. Check and, if necessary, adjust the handbrake.

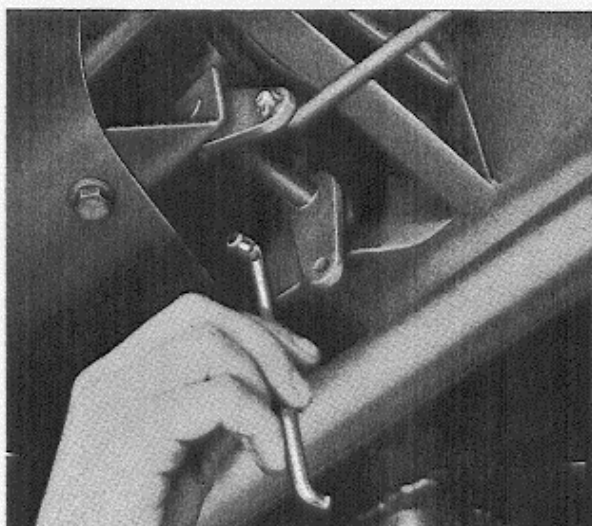
### Adjusting the handbrake

1. Adjust the rear wheel brake units as described in points 1—3 under "Adjusting the wheel brake units".

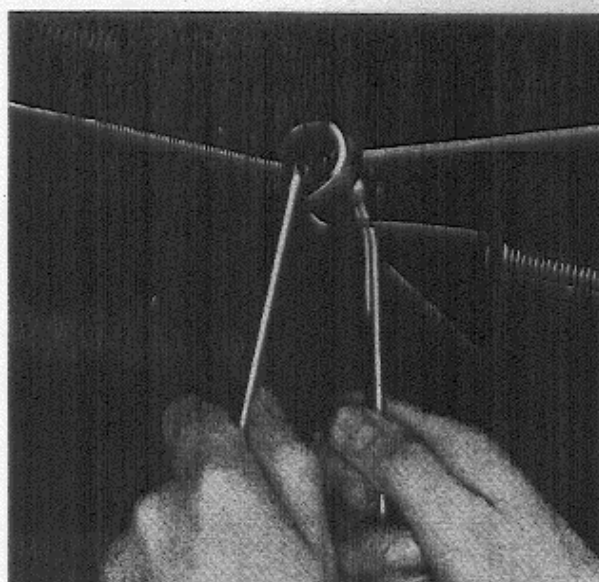
VOLVO  
25065

Fig. 34. Removing the shaft

2. Check that the handbrake gives full effect at the 4—5th notch on the ratchet. If this is not the case, adjust the handbrake by moving the clevis on the pull rod as shown in Fig. 35. On late production with a spring on the pull rod, the rear nut is tightened so that the spring just begins to tension.

## FAULT TRACING

REASON	REMEDY
--------	--------

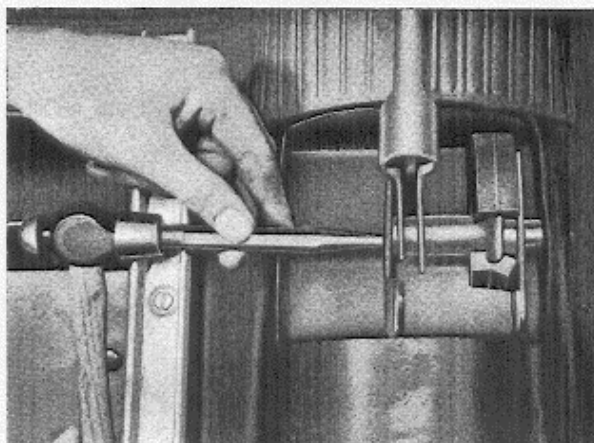
FAULT

### No or poor braking effect

<p>Pedal free travel too great. Too little brake fluid in the system.</p> <p>Air in the hydraulic system. Leakage in the hydraulic system. Defective master cylinder. Faultily adjusted brakes. Unsuitable brake linings. Grease or oil on the brake linings.</p>	<p>Adjust free travel. Fill up with brake fluid. Check for leakage. Vent. Vent the system. Check and repair the leakage. Vent. Overhaul the master cylinder. Adjust the brakes. Replace with original brake linings. Replace the linings. Check the sealing ring.</p>
---	---

### Car pulls to one side when braking

<p>Grease or oil on one of the brake linings.</p> <p>Different types of brake linings. Unevenly adjusted brakes. Out-of-round or uneven brake drums. Defective wheel unit cylinder. Excessive play in the wheel bearings or faulty front wheel alignment. Uneven tyre pressure. Tyres unevenly worn.</p>	<p>Replace the brake linings. Check the sealing ring. Fit same type of brake linings. Adjust the brakes. Replace or grind the drum. Overhaul the wheel unit cylinder.</p> <p>Adjust the front end. Adjust tyre pressure. See Part 7.</p>
--	--

### Brakes grab

<p>Badly adjusted brakes. Moisture on the brake linings.</p> <p>Too large a clearance in the wheel bearings. Worn—out brake linings. Oil carbonized on the brake linings. Damaged or loose brake linings. Loose brake backing plate. Out-of-round brake drum. Broken return spring. Wheel brake unit centering block damaged. Uneven sliding surfaces on the shoes and centering block.</p>	<p>Adjust the brakes. Apply the brakes repeatedly until the fault disappears. Adjust the bearings. Replace the linings. Replace the linings and repair the leakage. Replace the linings. Tighten brake backing plate. Replace or grind the drum. Replace the spring. Replace the centering block.</p> <p>Polish the sliding surfaces.</p>
---	---

### Brakes bind on all wheels

<p>Brakes faultily adjusted. The pedal has too small a free travel and obstructs the equalizing hole. Equalizing hole blocked up with dirt. During very cold weather: poor quality brake fluid.</p>	<p>Adjust brakes.</p> <p>Adjust the pedal free travel. Overhaul the master cylinder. Change the brake fluid.</p>
---	--

### **Brake binds on one of the wheels**

Brake faultily adjusted.	Adjust the brake.
Broken return spring.	Replace the spring.
Handbrake cable jamming.	Lubricate or replace the cable.
Brake pipeline to the wheel blocked or damaged.	Clean or replace the pipeline.
Excessive play in wheel bearings.	Adjust the bearings.

### **Brakes squeal**

Brake linings worn out.	Replace the linings.
Dirt in the brake drums.	Clean the drums and linings.
Brake drums vibrate.	Fit damping springs on the outside of the drums

## TOOLS

The following tools are used for repairing the brake system.

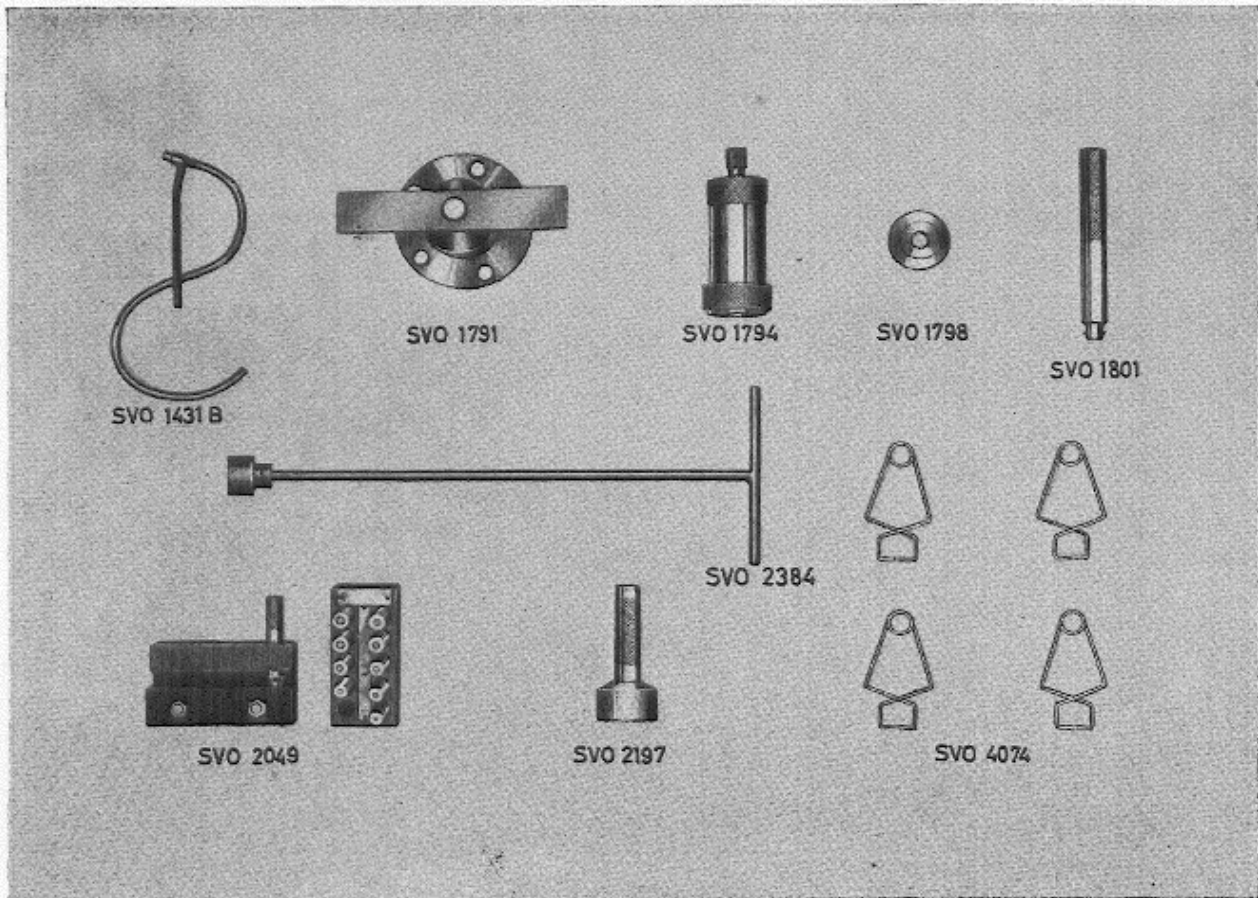

Fig. 36. Special tools

- |          |  |          |  |
|----------|--|----------|--|
| SVO 1431 | Key for venting nipple.                            | SVO 1801 | Standard handle.   |
| SVO 1791 | Puller for hub and brake drum.                     | SVO 2049 | Tool for flanging brake pipes.                                 |
| SVO 1794 | Puller for inner bearing on front stub axle.       | SVO 2197 | Drift for removing and fitting grease cap for front wheel hub. |
| SVO 1798 | Drift for fitting sealing ring in front wheel hub. | SVO 2384 | Wrench for master cylinder filler cap.                         |
|          |  | SVO 4074 | Spring clamp for wheel unit cylinder.                          |

