

SERVICE MANUAL

PV 544

B16
6VOLT

B18
12VOLT

Part 13

SPECIFICATIONS

(11)

Service Department

AKTIEBOLAGET

VOLVO

GÖTEBORG SWEDEN

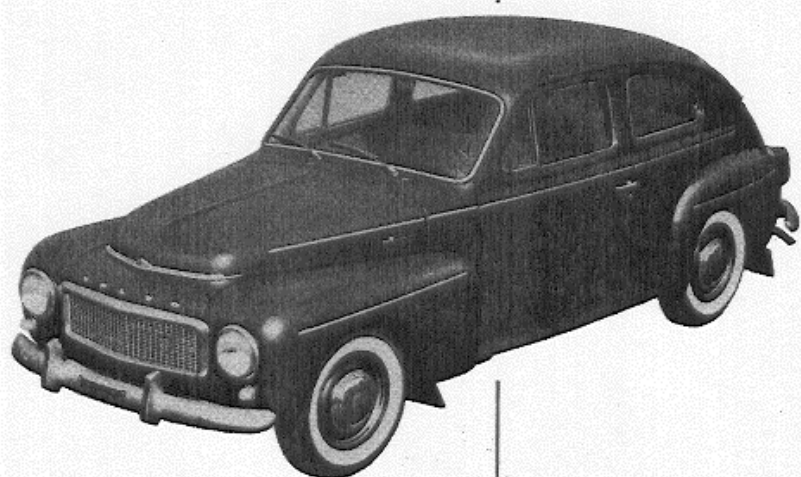

CONTENTS (ii)

Type designations	1
General information	2
B 16 engine	3
B 18 engine	8
Clutch	14
Gearbox	14
Propeller shaft	16
Rear axle	16
Front axle and steering gear	17
Brakes	17
Wheels	18
Springs and shock absorbers	18
Electrical system, B 16	19
Electrical system, B 18	22
Lubrication	24

TYPE DESIGNATIONS

These specifications concern the Volvo PV 544 car.

Type designation	Model	Engine	Gearbox	Final drive ratio
P 54403 A	Standard	B 16 A	H 6	4.56:1
P 54404 A	Special II	B 16 A	M 4	4.1 :1 *)
P 54405 A	Special I	B 16 A	H 6	4.56:1
P 54406 A	Sport	B 16 B	M 4	4.1 :1
P 544-11121 B	Standard	B 16 A	H 6	4.56:1
P 544-11132 B	Special I	B 16 A	M 4	4.1 :1
P 544-11134 B	Special II	B 16 A	M 6	4.56:1
P 544-11234 B	Sport	B 16 B	M 4	4.1 :1
P 544-11121 C	Favorit	B 18 A	M 30	4.1 :1
P 544-11132 C	Special	B 18 A	M 40	4.1 :1
P 544-11234 C	Sport	B 18 D	M 40	4.1 :1

* With the exception of chassis numbers 256222—260000 (approx.) which were supplied with 4.56:1 final drive.

PV 5440 A was introduced in Aug.—Sept. 1958.

PV 544 A chassis numbers 196005—295499 Aug. 1958—Aug. 1960.

PV 544 B chassis numbers 295000—330099 Aug. 1960—Aug. 1961.

PV 544 C chassis numbers 330100— Aug. 1961—

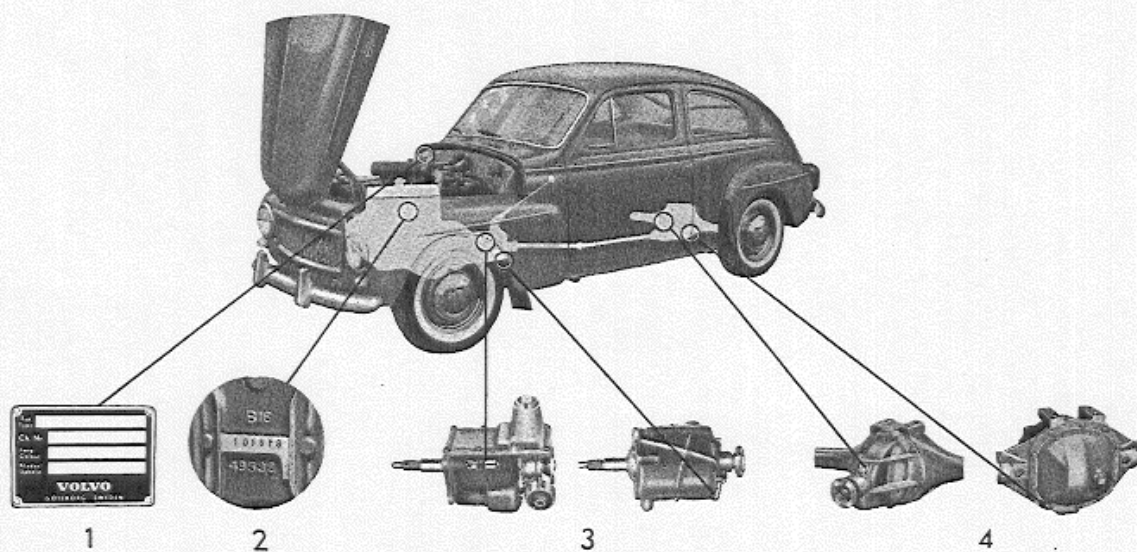

1. Type designation of car, serial number of chassis, code number for finish colour and upholstery. On late production models, the chassis number is stamped on the bulkhead.
 2. Engine type designation, manufacturing serial number and part number.
 3. Gearbox type designation, manufacturing serial number and part number.
 4. ENV rear axle: No. of teeth and manufacturing serial number stamped on front part of housing. Spicer: No. of teeth and ratio on plate attached to lower part of inspection cover.
- In addition to these plates, there is a further plate showing the body number attached to the bulkhead.

GENERAL INFORMATION

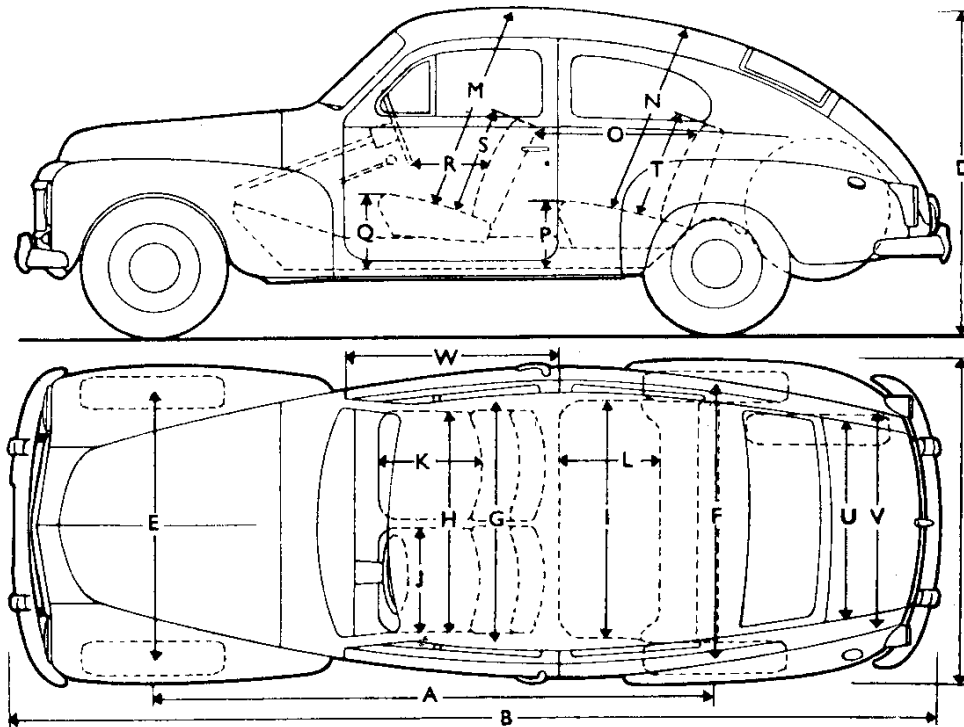

VOLVO
26339

Dimensions

A Wheelbase	2600 mm (102.36")	O Distance from front seat backrests—rear seat cushion at knee height	670 mm (26.38")
B Overall length	4450 mm (175.20")	P Height over floor, rear seat	370 mm (15.57")
C Width overall	1590 mm (62.60")	Q Height over floor, front seats	350 mm (13.78")
D Height overall	1560 mm (61.42")	R Distance, steering wheel—backrest	355 mm (13.98")
Ground clearance	210 mm (8.27")	S Height, front backrest	510 mm (20.10")
E Track, front	1295 mm (50.98")	T Height, rear backrest	570 mm (22.44")
F Track, rear	1315 mm (51.78")	U Width, luggage compartment (max. and min.)	990—810 mm (38.98"—31.89")
G Front seat width, shoulder height	1210 mm (47.64")	V Max. width, luggage accommodation	880 mm (34.64")
H Front seat width, hip height	1250 mm (49.21")	W Door width	1010 mm (39.80")
I Rear seat width, hip height	1320 mm (51.97")		
J Rear seat width, shoulder height	1210 mm (47.64")		
K Width, front seats	540 mm (21.26")		
L Length (depth), front seats	460 mm (18.11")		
M Depth, rear seat	440 mm (17.32")		
N Roof height over front seats, 15 cm(6") in front of backrest	960 mm (37.80")		
O Roof height over rear seat, 15 cm(6") in front of backrest	890 mm (35.04")		

Front seat can be adjusted ± 6 cm (0.24") lengthwise.

Turning circle diameter, early production 10800 mm (35'5")

Turning circle diameter, late production 9800 mm (32'2")

Weights

Type designation	Kerb weight including driver (75 kg=165 lb.)	Dry weight	Axle pressure (with kerb weight)	
			Front	Rear
P 54403 A	1040 kg (2295 lb.)	925 kg (2040 lb.)	535 kg (1180 lb.)	505 kg (1115 lb.)
P 54404 A	1060 kg (2340 lb.)	945 kg (2085 lb.)	545 kg (1200 lb.)	515 kg (1140 lb.)
P 54405 A	1060 kg (2340 lb.)	945 kg (2085 lb.)	545 kg (1200 lb.)	515 kg (1140 lb.)
P 54406 A	1080 kg (2380 lb.)	1010 kg (2270 lb.)	555 kg (1225 lb.)	525 kg (1115 lb.)
P 544-11121 B	1060 kg (2340 lb.)	945 kg (2085 lb.)	545 kg (1200 lb.)	515 kg (1140 lb.)
P 544-11132 B	1060 kg (2340 lb.)	945 kg (2085 lb.)	545 kg (1200 lb.)	515 kg (1140 lb.)
P 544-11134 B	1070 kg (2360 lb.)	955 kg (2105 lb.)	550 kg (1210 lb.)	520 kg (1150 lb.)
P 544-11234 B	1070 kg (2360 lb.)	955 kg (2105 lb.)	550 kg (1210 lb.)	520 kg (1150 lb.)
P 544-11121 C	1060 kg (2340 lb.)	945 kg (2085 lb.)	545 kg (1200 lb.)	515 kg (1140 lb.)
P 544-11132 C	1070 kg (2360 lb.)	955 kg (2105 lb.)	550 kg (1210 lb.)	520 kg (1150 lb.)
P 544-11134 C	1070 kg (2360 lb.)	955 kg (2105 lb.)	550 kg (1210 lb.)	520 kg (1150 lb.)

B 16 ENGINE

General

	B 16 A	B 16 B
Type designation	60/4500 (DIN)	76/5500 (DIN)
Output, b.h.p./r.p.m.	66/4500 (SAE)	85/5500 (SAE)
Max. torque, kgm (lb. ft.)/r.p.m.	11.3 (81.7)/2500 (DIN)	11.5 (83.1)/3300 (DIN)
	11.8 (85.4)/2500 (SAE)	12 (86.8)/3500 (SAE)
Compression pressure (warm engine) when turning over by using starter engine, 200 r.p.m., kg/cm ²	9.5—10.5	10—11
	135—150 lb./sq. in.	142—156
Compression ratio	7.4: 1	8.2: 1
Number of cylinders	4	4
Bore	79.37 mm (3.125")	79.37 mm (3.125")
Stroke	80 mm (3.15")	80 mm (3.15")
Displacement	1.58 litres (96.4 cu. in.)	1.58 litres (96.4 cu. in.)
Weight, including clutch, carburetter, starter motor, dynamo and air cleaner	approx. 150 kg (330 lb.)	approx. 150 kg (330 lb.)

Cylinder block

The cylinder bores are drilled directly in the block.

Material	Special-alloy cast-iron
Bore, standard	79.37 mm (3.125")
0.020" oversize	79.88 mm (3.145")
0.030" "	80.13 mm (3.155")
0.040" "	80.39 mm (3.165")
0.050" "	80.64 mm (3.175")

Pistons

Material	Light-alloy
Weight	410±5 grams (14.46±0.18 oz.)
Permissible weight difference between pistons on the same engine	10 g (0.35 oz.)
Total height	86 mm (3.390")
Height from piston pin centre to piston top	46 mm (1.81")
Piston clearance	0.03—0.05 mm (0.0012—0.0020")
Diameter, standard, at right angle to piston pin at lower edge of piston	79.33 mm (3.1230")
0.020" oversize	79.84 mm (3.1431")
0.030" "	80.09 mm (3.1535")
0.040" "	80.35 mm (3.1638")
0.050" "	80.60 mm (3.1736")

Piston rings

Piston ring gap measured in ring opening	0.25—0.50 mm (0.0027—0.0031")
Piston ring oversizes	0.020" 0.040" 0.030" 0.050"

Compression rings

Both rings are beveled on the inner edge and this bevel should be turned upwards.

The rings are also marked "TOP" on the upper surface.

The upper ring on each piston is chromed.

Number of rings on each piston	2
Height	1.97 mm (0.078")
Piston ring clearance in groove	0.068—0.079 mm (0.0027—0.0031")

Oil rings

	B 16 A	B 16 B
Number on each piston	1	
Height	4.73 mm (0.1865")	
Piston ring clearance in groove	0.045—0.073 mm (0.0017—0.0029")	

Piston pins

Fully floating. Circlips at both ends in piston.

Fit:

In connecting rod	Close running fit
In piston	Slide fit
Diameter, standard	19 mm (0.748")
0.05 mm oversize	19.05 mm (0.750")
0.10 mm "	19.10 mm (0.752")
0.20 mm "	19.20 mm (0.754")

Cylinder head

Height, measured from cylinder head contact surface to cylinder head nut flats	99 mm (3.90")
	97.5 mm (3.84")

Crankshaft

Replaceable bearing shells for main bearings and connecting rod bearings.

Crankshaft end play	0.01—0.10 mm (0.0004—0.0040")	0.01—0.10 mm (0.0004—0.0040")
Main bearings, radial play, flange bearing	0.014—0.064 mm (0.0005—0.0025")	0.014—0.064 mm (0.0005—0.0025")
others	0.014—0.064 mm (0.005—0.0025")	0.051—0.100 mm (0.0020—0.0034")
Connecting rod bearings, radial play	0.051—0.091 mm (0.0020—0.0036")	0.051—0.087 mm (0.0020—0.0034")

Main bearings

Main bearing journals

Diameter, standard	53.950—53.960 mm (2.1240—2.1244")
0.010" undersize	53.696—53.706 mm (2.1140—2.1144")
0.020" "	53.442—53.452 mm (2.1040—2.1044")
0.030" "	53.188—53.198 mm (2.0940—2.0944")
0.040" "	52.934—52.944 mm (2.0840—2.0844")

Width on crankshaft for flange bearing shell:

Standard	38.935—38.975 mm (1.5329—1.5344")
Oversize 0.1 mm (undersize shell 0.010")	39.035—39.075 mm (1.5369—1.5384")
0.2 mm (" " 0.020")	39.135—39.175 mm (1.5407—1.5423")
0.3 mm (" " 0.030")	39.235—39.275 mm (1.5447—1.5463")
0.4 mm (" " 0.040")	39.335—39.375 mm (1.5486—1.5502")

Main bearing shells

Flange bearing shells:

Thickness, standard	1.911—1.918 mm (0.0752—0.0755")
0.010" undersize	2.038—2.045 mm (0.0802—0.0805")
0.020" "	2.165—2.172 mm (0.0852—0.0855")
0.030" "	2.292—2.299 mm (0.0902—0.0905")
0.040" "	2.419—2.426 mm (0.0952—0.0955")

Other bearing shells:	B 16 A	B 16 B
Thickness, standard	1.911—1.918 mm (0.0752—0.0755")	1.894—1.900 mm (0.0746—0.0748")
0.010" undersize	2.038—2.045 mm (0.0802—0.0805")	2.021—2.027 mm (0.0796—0.0798")
0.020" "	2.165—2.172 mm (0.0852—0.0855")	2.148—2.154 mm (0.0854—0.0848")
0.030" "	2.292—2.299 mm (0.0902—0.0905")	2.275—2.281 mm (0.0895—0.0898")
0.040" "	2.419—2.426 mm (0.0952—0.0955")	2.402—2.408 mm (0.0946—0.0948")

Connecting rod bearings

Connecting rod bearing journals

Bearing seat width	32.900—33.000 mm (1.2953—1.2992")
Diameter, standard	47.589—47.600 mm (1.8736—1.8740")
0.010" undersize	47.335—47.347 mm (1.8635—1.8640")
0.020" "	47.081—47.092 mm (1.8536—1.8540")
0.030" "	46.827—46.838 mm (1.8436—1.8440")
0.040" "	46.573—46.584 mm (1.8336—1.8520")

Connecting rod bearing shells

Thickness, standard	1.560—1.568 mm (0.0614—0.0617")	1.562—1.568 mm (0.0615—0.0617")
0.010" undersize	1.687—1.695 mm (0.0664—0.0667")	1.689—1.695 mm (0.0665—0.0667")
0.020" "	1.814—1.822 mm (0.0715—0.0717")	1.816—1.822 mm (0.0715—0.0717")
0.030" "	1.941—1.949 mm (0.0764—0.0767")	1.943—1.949 mm (0.0765—0.0767")
0.040" "	2.068—2.076 mm (0.0814—0.0817")	2.070—2.076 mm (0.0815—0.0817")

Connecting rods

Marked 1—4 on side away from camshaft. Classified A—D showing weight range. Only connecting rods with the same weight classification may be used in the same engine.

Weight class A	578—608 grams (20.39—21.44 oz.)
B	608—638 grams (21.44—22.50 oz.)
C	638—668 grams (22.50—22.56 oz.)
D	668—698 grams (23.56—24.62 oz.)
Side clearance at crankshaft	0.15—0.35 mm (0.0060—0.0140")
Length, centre—centre	150 ± 0.1 mm (5.905 ± 0.004")

Flywheel

Permissible axial play	0.20 mm (0.008")
Ring gear (chamfer facing inwards)	116 teeth

Flywheel housing

Maximum axial play for rear surface	0.08 mm (0.0016")
Maximum radial play for rear guide	0.15 mm (0.0060")

Camshaft

	B 16 A	B 16 B
Drive	Gear drive with fibre gear on camshaft	
Number of bearings	3	
Forward bearing journal, diameter	46.975—47.000 mm (1.8494—1.8504")	
Centre bearing journal, diameter	42.975—43.000 mm (1.6919—1.6929")	
Rear bearing journal, diameter	36.975—37.000 mm (1.4557—1.4567")	
Radial clearance	0.025—0.075 mm (0.0010—0.0029")	
Valve clearance for check of camshaft setting (cold engine)	1.1 mm (0.043")	1.15 mm (0.045")
Inlet valve should then open at	10° before T.D.C.	0° (T.D.C.)

Camshaft bearings

Forward bearing, diameter	47.025—47.050 mm (1.8514—1.8524")
Centre bearing, diameter	43.025—43.050 mm (1.6939—1.6949")
Rear bearing, diameter	37.025—37.050 mm (1.4577—1.4587")

Timing gears

Crankshaft gear	20 teeth
Camshaft gear	40 teeth
Backlash	0.01—0.04 mm (0.0004—0.0016")

Valve system

Valves

Inlet

Disc diameter	37 mm (1.46")
Stem diameter	7.859—7.874 mm (0.3094—0.3100")
Valve seat angle	44.5°
Cylinder head seat angle	45°
Seat width in cylinder head	1.5 mm (0.060")

Exhaust

Disc diameter	34 mm (1.34")
Stem diameter	7.830—7.845 mm (0.3082—0.3089")
Valve seat angle	44.5°
Cylinder head seat angle	45°
Seat width in cylinder head	1.5 mm (0.060")

Valve clearances

Clearance, inlet valves, warm engine	0.40 mm (0.016")	0.50 mm (0.020")
Clearance, exhaust valves, warm engine	0.45 mm (0.018")	0.50 mm (0.020")

Valve guides

Length	62 mm (2.44")
Inner diameter	7.905—7.920 mm (0.311—0.312")
Height above cylinder head upper surface	21 mm (0.83")
Clearance, valve stem—valve guide, inlet valves	0.031—0.061 mm (0.0024—0.0035")
Clearance, valve stem—valve guide, exhaust valves	0.060—0.090 mm (0.0024—0.0035")

Valve springs

	B 16 A	B 16 B
Length, unloaded	45 mm (1.77")	
Length with loading of 25.5 ± 2 kg (56 ± 4 1/2 lb.)	39 mm (1.20")	
Length with loading of 66 ± 3.5 kg (145 ± 8 lb.)	30.5 mm (1.2")	

Lubricating system

Oil capacity, including oil cleaner	3.5 litres (3 Imp. quarts = 3 1/4 US quarts)
Oil capacity excluding oil cleaner	2.75 litres (2 1/2 Imp. quarts = 3 US quarts)
Oil pressure at 2000 r.p.m. (approx. 50 km.p.h. = 30 m.p.h. in top gear, warm engine)	2.5—3.5 kg/cm ² (36—50 lb./sq. in.)
Lubricant	Engine oil, Engine oil, Service MM or MS Service MS
viscosity, below 32° F (0° C)	SAE 10 W SAE 10 W
from 32° F (0° C) to 90° F (30° C)	SAE 20 SAE 20
above 90° F (30° C)	SAE 30 SAE 30
Oil cleaner, make	AC, Mann or Fram

Relief valve spring

Length, unloaded	40 ± 0.5 mm (1.575" ± 0.002")
Length, loaded with 2.5 ± 0.2 kg (5 1/2 ± 1/2 lb.)	34 mm (1.34")
3.5—0.2 kg (8 ± 1/2 lb.)	31.5 mm (1.24")

Lubricating oil pump

Oil pump, type	Gear pump
number of teeth	10
axial clearance	0.02—0.10 mm (0.0008—0.004")
radial clearance	0.01—0.10 mm (0.0004—0.004")
backlash	0.15—0.35 mm (0.006—0.014")

Fuel system

Fuel pump, make and type	AC diaphragm pump
Fuel pressure	min. 0.14 kg/cm ² (2 lb./sq. in.) max. 0.25 kg/cm ² (3.5 lb./sq. in.)
Capacity at idling speed	0.5 litres/min. (7/8 Imp. pint = 1 US pint/min.)
Fuel gauge, type	Electric
Fuel tank, capacity	35 litres (7 3/4 Imp. galls. = 9 1/4 US galls.)

Carburettors

B 16 A

Type	Down-draught
Make and designation	Zenith 34 VN
	Designation Dimensions
Venturi	27 —
Main jet, standard	97 0.97 mm
bentyl fuel	102 1.02 mm
Compensation jet	97 0.97 mm
Idling jet	50 0.50 mm
Idling air jet	50 0.50 mm
Acceleration jet	40 0.40 mm
Float valve	1.75
Float valve washer, thickness	1.0 mm
Fuel level when running	18 mm under float bowl top
Idling speed	400—600 r.p.m.

B 16 B

Type	Horizontal (2)
Make and designation	SU H4
Number of carburettors	2
Size (air intake diameter)	38 mm (1½")
Fuel control jet, designation	AUC 2112
Fuel needle, designation	GT
when using intake silencer air cleaner	GW
Rapid idling, setting of rod in cam-shaped lever	Position 2
Idling speed	500—700 r.p.m.

Cooling system

Type	Pressure
Filler cap valve opens at	0.23—0.30 kg/cm ² (3.2—4.2 lb.)
Capacity	approx. 8.5 litres (1 7/8 Imp. galls = 2 US galls.)
Thermostat balanced. Does not open under effect of water pump pressure.	
Marked	170
Starts to open at	75—78° C (167—172° F)
Fully open at	90° C (194° F)
Fan belt, designation	HC .380"×33"

Wear tolerances

Cylinders:	
Bore when worn (if oil consumption abnormal)	0.25 mm (0.010")
Crankshaft:	
Permissible out-of-round on main bearing journals, max.	0.05 mm (0.0020")
Permissible out-of-round on connecting rod bearing journals, max.	0.07 mm (0.0028")
Max. crankshaft end play	0.15 mm (0.0060")
Valves:	
Permissible clearance between valve stems and valve guides, max.	0.15 mm (0.0060")
Valve stems, permissible wear, max.	0.02 mm (0.0008")
Camshaft:	
Permissible out-of-round (with new bearings) max.	0.07 mm (0.0028")
Bearings, permissible wear	0.02 mm (0.0008")
Timing gears:	
Permissible backlash, max.	0.12 mm (0.0047")

Tightening torques, B 16 A and B 16 B engines

	Kgm	Lb. ft.
Cylinder head	7—8	50—60
Main bearings	8—10	60—70
Connecting rod bearings	4—5	30—35
Flywheel	2.3—2.7	17—20
Dynamo bolts (3/8"—16)	4	30
Oil cleaning centre bolts	5	36
Spark plugs, steel washers	4	30
copper washers	3.5	25
Crankshaft pulley nut and camshaft nut	15	108

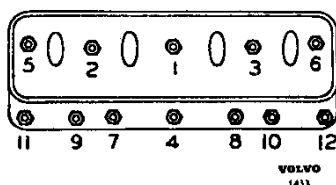

Tightening sequence for cylinder head nuts on B 16 engines.

B18 ENGINE

General

Type designation	B 18 A	B 18 D
Output, b.h.p. at r.p.m. (SAE)	75/4500	90/5000
(DIN)	68/4500	80/5000
Max. torque, kgm (lb. ft.) at r.p.m. (SAE)	14.0 (103)/2800	14.5 (105)/3500
(DIN)	13.5 (98)/2600	14.0 (103)/3000
Compression pressure (warm engine) when turned over with starter motor, 200 r.p.m., kg/cm ²	12—14	12—14
lb./sq. in.	170—200	170—200
Compression ratio	8.5: 1	8.5: 1
Number of cylinders	4	4
Bore	84.14 mm	84.14 mm
Stroke	80 mm	80 mm
Displacement	1.78 litres	1.78 litres

Cylinder block

Material	Special-alloy cast-iron
Bore, standard	84.14 mm (3.313")
0.020" oversize	84.65 mm (3.363")
0.030" "	84.90 mm (3.342")
0.040" "	85.16 mm (3.353")
0.050" "	85.41 mm (3.362")

Pistons

Material	Light-alloy
Weight	425 ± 5 g (15 ± 0.18 oz.)
Permissible weight difference between pistons in same engine	10 g (0.35 oz.)
Height, total	83.5 mm (3.29")
Height from piston pin centre to piston top	46 mm (1.81")
Piston clearance	0.03—0.05 mm (0.0012—0.0020")
Diameter, measured at right angles to piston pin	12.5 mm (0.10")
12.5 mm (0.10") from lower edge of piston:	
Standard Class C	84.095 mm (3.3108")
Class D	84.105 mm (3.3112")
Class E	84.115 mm (3.3116")
0.020" oversize	84.615 ± 0.01 mm (3.3313 ± 0.0004")
0.030" "	84.685 ± 0.01 mm (3.3411 ± 0.0004")
0.040" "	85.125 ± 0.01 mm (3.3514 ± 0.0004")
0.050" "	85.375 ± 0.01 mm (3.3612 ± 0.0004")

Piston rings

Piston ring gap measured in ring opening	0.25—0.50 mm (0.010—0.020")
Piston ring oversizes	0.020" 0.040" 0.030" 0.050"

Compression rings

Marked "TOP". Upper ring on each piston chromed.

Number of rings on each piston	2
Height	1.98 mm (0.078")
Piston ring clearance in groove	0.054—0.092 mm (0.0021—0.0036")

Oil control rings

Number on each piston	1
Height	4.76 mm (0.187 = 3/16")
Piston ring clearance in groove	0.044—0.072 mm (0.0017—0.0028")

Piston pins

Floating fit. Circlips at both ends in piston.

Fit:		
In connecting rod		Close running fit
In piston		Slide fit
Diameter, standard		22 mm (0.866")
0.05 mm (0.002") oversize		22.05 mm (0.868")
0.10 mm (0.004") "		22.10 mm (0.870")
0.20 mm (0.008") "		22.20 mm (0.874")

Cylinder head

Height, measured from cylinder head contact surface to bolt head level	88 mm (3.46")
Distance from upper surface of cylinder head to upper end of relief pipe (pipe located under thermostat)	35 mm (1.38")

Crankshaft

Crankshaft axial clearance	0.017—0.108 mm (0.007—0.0042")
Main bearings, radial clearance	0.026—0.077 mm (0.0010—0.0030")
Connecting rod bearings, radial clearance	0.039—0.081 mm (0.0015—0.0032")

Main bearings

Main bearing journals

Diameter, standard	63.441—63.454 mm (2.4977—2.4982")
undersize 0.010"	63.187—63.200 mm (2.4877—2.4882")
0.020"	62.933—62.946 mm (2.4777—2.4782")
0.030"	62.679—62.692 mm (2.4677—2.4682")
0.040"	62.425—62.438 mm (2.4577—2.4582")
0.050"	62.171—62.184 mm (2.4477—2.4482")
Width on crankshaft for flange bearing shell	
Standard	38.930—38.970 mm (1.5327—1.5342")
Oversize 1 (undersize shell 0.010")	39.031—39.072 mm (1.5367—1.5383")
2 (" " 0.020")	39.133—39.173 mm (1.5407—1.5422")
3 (" " 0.030")	39.235—39.275 mm (1.5447—1.5463")
4 (" " 0.040")	39.336—39.376 mm (1.5487—1.5502")
5 (" " 0.050")	39.438—39.478 mm (1.5527—1.5543")

Main bearing shells

Thickness, standard	1.985—1.991 mm (0.0781—0.0784")
undersize 0.010"	2.112—2.118 mm (0.0831—0.0834")
0.020"	2.239—2.245 mm (0.0881—0.0884")
0.030"	2.366—2.372 mm (0.0931—0.0934")
0.040"	2.493—2.499 mm (0.0981—0.0984")
0.050"	2.620—2.626 mm (0.1031—0.1034")

Connecting rod bearings**Connecting rod bearing journals**

Bearing seat width	31.950—32.050 mm (1.2579—1.2618")
Diameter, standard	54.089—54.102 mm (2.1295—2.1300")
0.010"	53.835—53.848 mm (2.1195—2.1200")
0.020"	53.581—53.594 mm (2.1095—2.1100")
0.030"	53.327—53.340 mm (2.0995—2.1000")
0.040"	53.073—53.086 mm (2.0895—2.0900")
0.050"	52.819—52.832 mm (2.0795—2.0800")

Connecting rod bearing shells

Thickness, standard	1.833—1.841 mm (0.0722—0.0725")
undersize 0.010"	1.960—1.968 mm (0.0772—0.0775")
0.020"	2.087—2.095 mm (0.0822—0.0825")
0.030"	2.214—2.222 mm (0.0872—0.0875")
0.040"	2.341—2.349 mm (0.0922—0.0925")
0.050"	2.469—2.476 mm (0.0972—0.0975")

Connecting rods

Axial clearance at crankshaft	0.15—0.35 mm (0.006—0.014")
Length, centre—centre	145 ± 0.1 mm (5.710 ± 0.004")
Maximum permissible difference in weight between connecting rods in same engine	6 g (0.21 oz.)

Flywheel

Permissible axial throw, max.	0.20 mm (0.008")
Ring gear (bevel facing forwards)	142 teeth

Flywheel housing

Permissible axial throw, max.	0.05 mm/100 mm diam. (0.002"/4" diam.)
Max. radial throw for rear guide	0.15 mm (0.006")

Camshaft

Number of bearings	3
Front bearing journal, diameter	46.975—47.000 mm (1.8494—1.8504")
Centre bearing journal, diam.	42.975—43.000 mm (1.6919—1.6929")
Rear bearing journal, diam.	36.975—37.000 mm (1.4557—1.4567")
Radial clearance	0.020—0.075 mm (0.0008—0.0030")
Axial clearance	0.020—0.060 mm (0.0008—0.0024")
Valve clearance for check of camshaft setting (cold engine)	1.1 mm (0.043")
Inlet valve should then open at	10° after T.D.C.

Camshaft bearings

Front bearing, diameter	47.020—47.050 mm (1.8512—1.8524")
Centre bearing, diameter	43.025—43.050 mm (1.6939—1.6949")
Rear bearing, diameter	37.020—37.045 mm (1.4575—1.4585")

Timing gears

Crankshaft gear, number of teeth	21
Camshaft gear, (fibre), number of teeth	42
Backlash	0.04—0.08 mm (0.0016—0.0032")
Axial clearance, camshaft	0.02—0.006 mm (0.0008—0.0023")

Valves

Inlet

Disc diameter	40 mm (1.58")
Stem diameter	8.685—8.700 mm (0.3419—0.3425")
Valve seat angle	44.5°
Cylinder head seat angle	45°
Seat width in cylinder head	1.5 mm (0.060")
Clearance, warm and cold engine	0.40—0.45 mm (0.016—0.018")

Exhaust

Disc diameter	35 mm (1.38")
Stem diameter	8.645—8.660 mm (0.3403—0.3409")
Valve seat angle	44.5°
Cylinder head seat angle	45°
Seat width in cylinder head	1.5 mm (0.060")
Clearance, warm and cold engine	0.40—0.45 mm (0.016—0.018")

Valve guides

Length	63 mm (2.48")
Inner diameter	8.725—8.740 mm (0.3435—0.3441")
Height above upper surface of head	21 mm (0.83")
Clearance, valve stem—guide, inlet valves	0.025—0.055 mm (0.0010—0.0022")
exhaust valve	0.065—0.095 mm (0.0026—0.0037")

Valve springs

Length, unloaded, approx.	45 mm (1.77")
loaded with 25.5 ± 2 kg (56 ± 4 1/2 lb.)	39 mm (1.54")
66 ± 3.5 kg (145 ± 8 lb.)	30.5 mm (1.20")

Lubricating system

Oil capacity, including oil cleaner	3.75 litres (3 1/2 Imp. qts. = 4 US qts.)
excluding oil cleaner	3.25 litres (3 1/4 Imp. qts. = 3 1/2 US qts.)
Oil pressure at 2,000 r.p.m. (with warm engine and new oil cleaner)	4.0—6.0 kg/cm ² (56—85 lb./sq. in.)
Lubricant	Engine oil, Service MS
viscosity, below 0° C (30° F)	SAE 10 W
between 0° C (30° F) and +30° C (90° F)	SAE 20
above +30° C (90° F)	SAE 30
	} or multigrade oil SAE 10 W—30

Lubricating oil cleaner

Type	Fullflow
Make	Wix or Mann

Lubricating oil pump

Oil pump, type	Gear pump
number of teeth on each gear	10
axial clearance	0.02—0.10 mm (0.0008—0.0040")
radial clearance	0.08—0.14 mm (0.0032—0.0055")
backlash	0.15—0.35 mm (0.0060—0.0140")

Relief valve spring (in oil pump)

Length, unloaded	31 mm (1.22")
loaded with 4.0±0.2 kg (9±1/2 lb.)	27.5 mm (1.08")
9.5±0.3 kg (21±3/4 lb.)	22.5 mm (0.88")

Fuel system

Fuel pump

Fuel pump, type	AC diaphragm pump UG
Fuel pressure, measured at same height as pump	min. 0.1 kg/cm ² (1.5 lb./sq. in.) max. 0.18 kg/cm ² (2.5 lb./sq. in.)

Carburetter, B 18 A

Type	Down-draught
Type and designation	Zenith 36 VN
Venturi	30
Main jet	117
Compensation jet	115
Idling jet	70
Idling air jet	70
Air jet for acceleration	140
Acceleration jet	40
Acceleration pump stroke	Short
Float valve	1.75
Washer for float valve, thickness	1 mm
Idling speed (warm engine)	500—700 r.p.m.

Carburetter, B 18 D

Type	Horizontal, twin
Make and type	SU—HS 6
No. of carburetters	2
Size (air intake)	44.5 mm (1 3/4")
Fuel needle, designation	K . A
Idling speed	500—700 r.p.m.
Oil for damping cylinders	SAE 20 engine oil (<i>not</i> multigrade)

Ignition system

Voltage	12 V
Order of firing	1—3—4—2
Ignition timing setting with stroboscope at 1500 r.p.m. 97 octane (Research Method) (vacuum regulator disconnected). Accurate adjustment cannot be carried out on stationary engine)	21—23° before T.D.C. (B 18 A) 22—24° before T.D.C. (B 18 D)
Spark plugs	Bosch W 175 T1 or corresponding
Spark plug gap	0.7—0.8 mm (0.028—0.032")
tightening torque	3.8—4.5 kgm (28—32 lb. ft.)

Wear tolerances

Cylinders:	
To be rebored when wear reaches (if engine shows abnormal oil consumption)	0.25 mm (0.010")
Crankshaft:	
Permissible out-of-round on main bearing journals, max.	0.05 mm (0.002")
Permissible out-of-round on connecting rod bearing journals, max.	0.07 mm (0.003")
Valves:	
Permissible clearance between valve stems and valve guides, max.	0.15 mm (0.006")
Valve stems, permissible wear, max.	0.02 mm (0.0008")
Camshaft:	
Permissible out-of-round (with new bearings) max. ...	0.07 mm (0.003")
Bearings, permissible wear	0.02 mm (0.0008")
Timing gears:	
Permissible backlash, max.	0.12 mm (0.005")

CLUTCH

For B 16

Type	Single dry disc
Size	8"
Friction area, total	340 cm ² (52.7 sq. in.)
Thickness of clutch plate when fitted	7.0—7.5 mm (0.276—0.295")
Rivets for clutch facings:	
Number	16
Size	$\frac{9}{64}'' \times \frac{1}{4}''$ (3.5 × 6.5 mm)
Distance between the flywheel and clutch release lever contact surface with the relief bearing	46 mm (1.81")
Clutch springs:	
B 16 A, early production and B 16 B:	
Colour: Neutral	
Length, loaded with 85.5—90.5 kg (188—199 lb.)	38 mm (1.496")
B 16 A, late production:	
Colour: Light yellow and light green	
Length, loaded with 82—86 kg (180—189 lb.)	40 mm (1.575")
Number	6
Adjusting the clutch release levers:	
Alternative I 7.5 mm (0.295") lower than the hub in adjusting jig SVO 2065 within a limit of ± 1.5 mm (0.06") and within 0.25 mm (0.010") of each other.	
Alternative II, adjustment 40.5 in clutch fixture SVO 2322, packing blocks number 0.	
Clutch fork free travel	10—15 mm (0.39—0.59")

For B 18

Type	Single dry disc
Size	8 $\frac{1}{2}$ " (215.9 mm)
Friction area, total	440 cm ² (68.2 sq. in.)
Clutch plate thickness when fitted	7.0—7.5 mm (0.276—0.295")
Rivets for clutch facings, number	16
Distance between the clutch release lever contact surface for the release bearing and flywheel	46 mm (1.81")

PV 544

Clutch springs:	
Number	6
Marking	Neutral
Length, loaded with 85.5—90.5 kg (188—199 lb.)	38 mm (1.496")
Adjustment of clutch release levers:	
Adjustment 41.5 in clutch fixture SVO 2322, packing blocks number 0.	
Clutch pedal free travel	10—15 mm (0.39—0.59")

G E A R B O X

H 6

Type designation, serial number and part number stamped on name plate fixed to left-hand side of gearbox.

2nd and 3rd speeds synchronized.

Type designation	H 6
Ratios:	
1st speed	3.13: 1
2nd speed	1.62: 1
3rd speed	1: 1
Reverse	2.66: 1
Number of teeth on the different gears:	
Input shaft	17
Countershaft, drive gear	24
Gear for 1st speed	14
Gear for 2nd speed	20
Main shaft, gear for 1st speed	31
Gear for 2nd speed	23
Reverse gears	17 and 20
Lubricant	Gear oil
Viscosity	SAE 80
Oil capacity	0.5 litre (7/8 Imp. pint=1 US pint)

M 4

Type designation, serial number and part number stamped on nameplate fixed to lower side of gearbox.

4-speed, fully synchronized.

Type designation	M 4
Ratios:	
1st speed	3.45: 1
2nd speed	2.18: 1
3rd speed	1.31: 1
4th speed	1: 1
Reverse	3.55: 1
Number of teeth on the different gears:	
Input shaft	18
Countershaft, drive gear	28
Gear for 1st speed	14
Gear for 2nd speed	20
Gear for 3rd speed	25
Gear for reverse	14
Main shaft, gear for 1st speed	31
Gear for 2nd speed	28
Gear for 3rd speed	21
Gear for reverse	32
Reverse gear	19
Lubricant	Gear oil
viscosity	SAE 80
Oil capacity	Approx. 0.9 litre (1 1/2 Imp. pints= 17/8 US pints)

Wheel alignment (unloaded vehicle)

Caster	$-3/4^\circ$ to $+1/4^\circ$
Camber	$-1/4^\circ$ to $+1/2^\circ$
King pin inclination at a camber of 0°	5°
Toe-in	0—3 mm (0.—0.12")
Steering geometry:	
When the outer wheel is turned 20° the inner wheel should be turned	$22^\circ \pm 1^\circ$

BRAKES

Wheel brake units

Brake drum:	Production I	Production II	Production III
Diameter, front	228.6 mm (9")	228.6 mm (9")	228.6 mm (9")
rear	228.6 mm (9")	228.6 mm (9")	228.6 mm (9")
Radial throw, max.	0.15 mm (0.006")	0.15 mm (0.006")	0.15 mm (0.006")
Brake linings:			
Width	2"	2"	2"
Thickness, rear lining, front wheel	$3/16$ "	$1/4$ — $3/16$ " (ground)	$3/16$ "
others	$3/16$ "	$3/16$ "	$3/16$ "
Hole diameter for contact plug	19 mm ($3/4$ ")	—	—
Length, front shoe	260 mm ($10 1/4$ ")	250 mm ($9 27/32$ ")	192 mm ($7 9/16$ ")
rear shoe	200 mm ($7 7/8$ ")	250 mm ($9 27/32$ ")	250 mm ($9 27/32$ ")
Brake lining rivets:			
Number	—	80	—
Size	—	$9/64 \times 5/16$ " (3.5 × 8 mm)	—
Return spring for brake shoe, pulling force at a total length of 154 mm ($6 1/16$ ")	—	15.5—20.5 kg (34.1—45.1 lb.)	—
Effective brake lining area	930 cm ² (144 sq. in.)	1016 cm ² (157.5 sq. in.)	902 cm ² (104 sq. in.)
Clearance between brake shoe and drum	—	0.10 mm (0.004")	—
Pedal clearance	—	7—12 mm ($9/32$ "— $15/32$ ")	—

Hydraulic system

Master cylinder:	Early prod.	Late prod.
Internal diameter	1" (25.4 mm)	1" (25.4 mm)
Clearance between plunger and cylinder	0.025—0.127 mm (0.001—0.005")	0.025—0.127 mm (0.001—0.005")
Wheel unit cylinders:		
Diameter, front	1" (25.4 mm)	1" (25.4 mm)
Diameter, rear	$7/8$ " (22.23 mm)	$13/16$ " (20.64 mm)
Clearance between plunger and cylinder	0.025—0.127 mm (0.001—0.005")	0.025—0.127 mm (0.001—0.005")
Brake lines:		
Diameter	$3/16$	$3/16$
Length, left, front	500 mm ($19 5/8$ ")	480 mm ($18 7/8$ ")
right, front	920 mm ($36 1/4$ ")	935 mm ($36 7/8$ ")
left, rear	500 mm ($19 5/8$ ")	505 mm ($19 7/8$ ")
right, rear	925 mm ($36 3/8$ ")	970 mm ($38 1/8$ ")
master cylinder—rear axle	2160 mm (85")	2150 mm ($84 5/8$ ")

WHEELS AND TYRES

Wheels

Type and designation	Disc wheel, 4J×15
Number of wheel nuts	5
Radial throw	Max. 2.5 mm (0.10")
Run-out	Max. 2.5 mm (0.10")
Unbalance (complete wheel)	Max. 900 gcm (0.8 lb.in.)
Tightening torque for wheel nuts	10—14 kgm (70—100 lb.ft.)

Tyres

Type	Tubeless
Size	5.90—15
Number of plies	4
Rolling radius	315 mm (12 3/8")
Number of wheel turns per km (mile)	Approx. 492 (787)
Tyre pressure (cold tyre), front	1.4 kg/cm ² (20 lb./sq.in.)
rear	1.6 kg/cm ² (23 lb./sq.in.)
for continuous driving between 140—160 km. p.h. (90—100 m.p.h.), front	1.8 kg/cm ² (26 lb./sq.in.)
rear	2.0 kg/cm ² (28 lb./sq.in.)

SPRINGS AND SHOCK ABSORBERS

Front spring

Type	Coil spring
Cross-sectional thickness of material	13.4—13.8 mm (0.527—0.543")
Internal diameter	82.3—82.45 mm (3.240—3.246")
Number of coils	8
Test values:	
Length loaded with 435±12 kg (957±26.4 lb.)	177 mm (7")
Length when fully compressed	Max. 113 mm (4 7/16")

Rear spring

Type	Coil spring
Cross-sectional thickness of material	11.7—11.9 mm (0.461—0.468")
Internal diameter	102—104 mm (4.016—4.094")
Number of coils	9
Test values:	
Length loaded with 215±8 kg (473±17.6 lb.)	242 mm (9 1/2")
Length when fully compressed	114 mm (4 1/2")

Shock absorbers

Type	Double-acting, hydraulic telescopic shock absorbers
Length measured between lug centres:	
Front shock absorber, compressed	approx. 200 mm (7 7/8")
extended	approx. 290 mm (11 3/8")
Rear shock absorber, compressed	approx. 300 mm (11 7/8")
extended	approx. 485 mm (19")

ELECTRICAL SYSTEM

Early type. For vehicles with B 16 engine

Battery

Make and designation	Tudor 3 Df6 or corresponding
Earthed	Negative terminal
Voltage	6 V
Battery capacity, standard	85 Ah (13 plate)
Electrolyte specific gravity, fully charged battery	1.275—1.285
Electrolyte specific gravity when battery need recharging	1.230

Ignition system

	B 16 A	B 16 B
Firing order	1—3—4—2	
Ignition setting:		
basic setting		
octane rating (Research Method) 87	2—4° B.T.D.C.	—
93	—	4° B.T.D.C.
97	2—4° B.T.D.C.	4—6° B.T.D.C.
stroboscope setting, 1500 engine r.p.m. (vacuum regulator disengaged)		
octane rating (Research Method) 87	19—21° B.T.D.C.	—
93	—	21° B.T.D.C.
97	19—21° B.T.D.C.	21—23° B.T.D.C.
Sparking plugs, normal driving	Bosch W 175 T3 Champion J7 or corresponding	Bosch W 225 T3 Champion J6 or corresponding
hard driving	Bosch W 225 T3 Champion J6 or corresponding	Bosch W 240 T3 Champion J6 or corresponding
Sparking plug gap	0.7—0.8 mm (0.028—0.032")	
Ignition coil	Bosch ZS/KZ 1/6/4	

Distributor

Make and type	Bosch VJU 4 BR 20
---------------------	-------------------

Test values

Rotation	Clockwise			
Ignition setting curves:				
Centrifugal governor				
Crankshaft degrees	0	10	20	27±3
Crankshaft r.p.m.	400—800	700—1100	1600—2500	3100—3800
Vacuum regulator				
Crankshaft degrees	0°		16±2°	
Vacuum, cm (in.) Hg	7—14 (2.76—5.51")		50 (19.68")	
Contact breakers, gap	0.4—0.5 mm (0.016—0.020")			
contact pressure	0.4—0.5 kg (0.88—1.10 lb.)			
closing angle	50±3°			

Dynamo

Make and designation, early production	Bosch LJ/GG 200/6-2300 R7	Bosch LJ/GG 200/6-2300 R7
late production	Bosch LJ/GG 200/6-2300 R6	Bosch LJ/GG 200/6-2300 R7
Voltage	6 V	
Earthed	Negative terminal	
Effect, continuous	Max. 49 A	
Direction of rotation	Clockwise	
Ratio, engine—dynamo	1: 1.8	
Brushes, designation, 2	WSK 40 L6	

Test values

Brush spring tension	0.45—0.60 kg (1.0—1.3 lb.)
Field winding	4 A at 5 V
Dynamo as motor	8 A at 5 V
Charging, cold dynamo:	
6.4 V 0 A	1850—1900 r.p.m.
8 V 40 A	2575—2675 r.p.m.
Charging, warm dynamo:	
6.4 V 0 A	1875—1950 r.p.m.
8 V 40 A	2750—2850 r.p.m.

Charging control

Make and designation	Bosch RS/UA 200/6/23
Equalizing resistance AR	5.5—6.0 Ohm
Control resistance W1	3.2—3.7 Ohm
Control resistance W2	5—6 Ohm

Test values

Reverse current relay:	
Adjusted for cutting-in at	5.5—6.3 V
Adjusted for cutting-out at, reverse current	4—9 A (closed circuit)
Voltage control:	
Control voltage adjusted to	7.0—7.5 V
Control current:	
Control current adjusted to	47—51 A
The test values for an ambient temperature of approx. 20° C (70° F).	

Starter motor

Make and designation	Bosch EGD 0.6/6 AR 19
Control solenoid, type designation	SSM 120/2
Voltage	6 V
Earthed	Negative terminal
Direction of rotation	Clockwise
Output	0.6 h.p. at —10° C (15° F)
	0.75 h.p. at 20° C (70° F)
Number of teeth on the pinion	9
Brushes, designation	DSK 35/5
number	4

Test values

Mechanical:	
Axial clearance of rotor	0.15—0.30 mm (0.006—0.012")
Brush spring tension	0.8—0.9 kg (1.76—2.0 lb.)
Distance from pinion to ring gear	3 mm (0.12")
Friction torque of rotor brake	3—5 kg. cm (2.6—4.3 lb. in.)
Pinion idling torque	0.4—0.8 kg. cm (0.35—0.7 lb. in.)
Electrical:	
Starter motor unloaded:	
Test time	Max. 15 seconds
5.5 V and 65—75 A	3,500—4,000 r.p.m.
Starter motor loaded:	
4.5 V and 260—280 A	750—850 r.p.m.
Starter motor locked (r.p.m. = 0):	
3.5 V and 450—480 A	Min. 1.33 kgm (9.4 lb. ft.)

Control solenoid

Test values

Current consumption of winding:

Between terminal 50 and earth	9—12 A at 5.0 V
Between terminal 50 and 30	31—35 A at 5.0 V
Control voltage, cutting-in	2.5—3.3 V
Control voltage, cutting-out	0.8—1.6 V
Distance "a" (see Fig.)	32.2 ± 0.1 mm (1.27 ± 0.004")

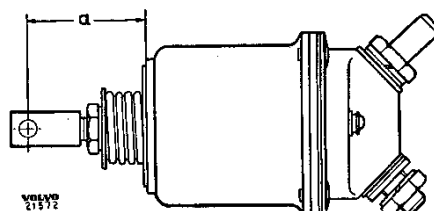

Adjusting the control solenoid (iron core withdrawn).

Fuses

Fuse box under bonnet on left-hand side of cowl	4 8A, 2 25A
Fuse box under bonnet on left-hand wheel housing (with effect from chassis number 21000)	4 8A

Bulbs

	Watts	Socket	Number
Headlights	45/40	BA 20 d	2
Long-time parking (up to chassis number 20999)	2	BA 9 s	4
Number plate lighting	5	BA 15 s	2
Stop lights (up to chassis number 20999)	20	BA 15 s	2
Rear lights (up to chassis number 20999)	5	BA 15 s	2
Combination stop and rear lights (up to chassis number 21000)	20/5	BA 15 d spec.	2
Instrument lighting	2	BA 9 s	2
Direction indicator and parking lights, front	20/5	BA 15 d spec.	2
Direction indicator lights, rear	20	BA 15 s	2
Glove compartment light	2	BA 9 s	1
Clock light	2	BA 9 s	1
Roof light	10	S 8	1
Control lamp for direction indicators	2	BA 9 s	1
headlights	2	BA 9 s	1
oil pressure	2	BA 9 s	1
charging	2	BA 9 s	1

Late production. For vehicles with B 18 engine

Battery

Type	Boliden 107GM60 or corresponding
Earthed	Negative terminal
Voltage	12 V
Battery capacity, standard	60 Ah
Electrolyte specific gravity:	
Fully charged battery	1.230
When recharging is necessary	1.275—1.285
Recommended charging current	4.5 A

Ignition system

Firing order	1—3—4—2
Ignition setting, with stroboscope at an engine speed of 1500 r.p.m. (vacuum regulator disconnected) octane rating 97 (Research Method). (Accurate adjusting with stationary engine must not be done)	21—23° B.T.D.C. B 18 A 22—24° B.T.D.C. B 18 D
Ignition coil	Bosch ZS/KZ/1/12A (14/3)
Sparking plugs, type	Bosch W 175 T 1 or corresponding
thread	14 mm
gap	0.7 mm (0.028")

Distributor

Type	Bosch VJU 4 BL 33
------------	-------------------

Test values

Direction of rotation	Clockwise
Ignition setting curves:	
Centrifugal regulator:	
Crankshaft degrees	0 10 22 22 ± 3
Crankshaft r.p.m.	750—1050 1300—1850 2300—2900 2800—3300
Vacuum regulator:	
Crankshaft degrees	6 15 ± 4
Vacuum, cm (in.) Hg	6—10 (2.36—3.94") 18 (7.09")
Contact breaker, gap,	0.4—0.5 mm (0.016—0.020")
contact pressure	0.4—0.5 kg (0.88—1.10 lb)
closing angle	60°

Dynamo

B 18 A, type	Bosch LJ/GG 240/12/2400 AR6
B 18 D, type	Bosch LJ/GG 240/12/2400 AR7
Voltage	12 V
Rated effect	240 W
Max. continuous effect	30 A (cold dynamo)
Earthed	Negative terminal
Direction of rotation	Clockwise
Ratio, engine—dynamo	1: 1.8
Brushes, designation	WSK 43 L1
number	2
contact pressure	450—600 g (16—21 oz.)

Test values

Field winding resistance	4.8 + 0.5 Ohm
Charging, cold dynamo, 240 W	2300 r.p.m.
warm dynamo, 240 W	2500 r.p.m.
Speed for rated voltage, unloaded	1700 r.p.m.

Charging control

Type	Bosch RS/VA 240/12/2
Equalizing resistance aR	15.5—16.5 ohm
Control resistance wR	8—9 ohm

Test values

Reverse current relay:	
Adjusted for, cutting-in at	12.4—13.1 V
reverse current at	2.0—7.5 A
Voltage control:	
Control voltage, dynamo unloaded (idling)	14.1—14.8 V
loaded	13.0—14.0 V
Loading current:	
Cold dynamo and control	45 A
Warm dynamo and control	30 A

Starter motor

Type	Bosch EGD 1/12 AR 37
Voltage	12 V
Earthed	Negative terminal
Direction of rotation	Clockwise
Output	Approx. 0.9 h.p. at -10°C (15°F)
	Approx. 1.2 h.p. at 20°C (70°F)
Number of teeth on pinion	9
Brushes, designation	DSK 35/5
number	4

Mechanical

Rotor axial clearance	0.1—0.3 mm (0.004—0.012")
Brush spring tension	0.8—0.9 kg (1.76—2.0 lb.)
Distance from pinion to ring gear	2.5—3.0 mm (0.10—0.12")
Friction torque of rotor brake	3—5 kg.cm (2.6—4.3 lb.in.)
Pinion idling torque	1.3—1.8 kg.cm (1.13—1.56 lb.in.)
Tooth flank clearance	0.35—0.6 mm (0.014—0.023")
Pinion modulus	2.11

Electrical

Starter motor unloaded:	
11.5 V and 40—60 A	5500—7500 r.p.m.
Starter motor loaded:	
10 V and 200 A	1100—1300 r.p.m.
Starter motor locked:	
r.p.m. = 0	8 V 400—450 A
Control solenoid:	
Cut-in voltage	Max. 7 V
Adjusting measurement "a" (see Fig.)	32.2 ± 0.1 mm (1.27 ± 0.004 ")

Bulbs

	Watts	Socket	Number
Headlights	45/40	Ba 20 d	2
Direction indicators/parking lights, front	20/5	Ba 15 d spec.	2
Direction indicators, rear	20	BA 15 s	2
Brake lights, parking lights, rear	20/5	Ba 15 d spec.	2
Number plate lighting	5	S 8	2
Internal lighting	10	S 8	1
Instrument lighting	2	Ba 9 s	2
Control lamp, direction indicators	2	Ba 9 s	1
Full headlights	2	Ba 9 s	1
Charging	2	Ba 9 s	1
Oil pressure	2	Ba 9 s	1

LUBRICATION

B 16 Engine

	B 16 A	B 16 B
Lubricant	Engine oil for Service MM or MS	Engine oil for Service MS
viscosity, summer	SAE 20	SAE 20
winter	SAE 10 W	SAE 10 W
Oil capacity, with oil cleaner	3.5 litres (3 Imp. quarts = 3 1/4 US quarts)	3.5 litres (3 Imp. quarts = 3 1/4 US quarts)
without oil cleaner	2.75 litres (2 1/2 Imp. quarts = 3 US quarts)	2.75 litres (2 1/2 Imp. quarts = 3 US quarts)
Oil for damping cylinders of carburetters	—	SAE 10 W

B 18 Engine

Lubricant	Engine oil Service MS or multi-grade oil 10 W—30
viscosity below 0° C (32° F)	SAE 10 W
above 0° C (32° F)	SAE 20
Oil capacity with oil cleaner	3.75 litres (3 1/2 Imp. quarts = 4 US quarts)
without oil cleaner	3.25 litres (3 1/4 Imp. quarts = 3 1/2 US quarts)

Gearbox

Early type (H 6)

Lubricant, type	Gear oil
viscosity	SAE 80
oil capacity	0.5 litre (7/8 Imp. pint = 1 1/2 US pints)

Late type (M 4)

Lubricant, type	Gear oil
viscosity	SAE 80
oil capacity	approx. 0.9 litre (1 5/8 Imp. pints = 1 7/8 US pints)

M 30, M 40

Lubricant, type	Gear oil
viscosity	SAE 80
oil capacity	0.75 litre (1 1/4 Imp. pints = 1 1/2 US pints)

Rear axle

Lubricant, type	Hypoid oil
viscosity	SAE 80
oil capacity	1.3 litres (2 3/8 Imp. pints = 2 3/4 US pints)

Steering box

Lubricant, type	Hypoid oil
viscosity	SAE 80
oil capacity	0.3 litre (3/8 Imp. pint = 3/4 US pint)